



UPF1080

80W, 1.0 GHz, 26V Broadband RF Power N-Channel Enhancement-Mode Lateral MOSFET

This device is designed for base station applications up to frequencies of 1.0 GHz. Rated with a minimum output power of 80W, it is ideal for CDMA, TDMA, GSM, FM, Single or Multi-Carrier Power Amplifiers in Class A or AB operation.

www.DataSheet4U.com

- ALL GOLD metal system for highest reliability.
- Industry standard package.
- Low intermodulation distortion of -30dBc at 80W (PEP).

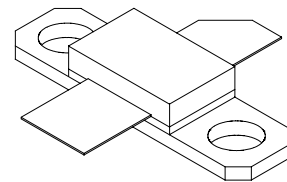

Package Type 440095

PN: UPF1080F

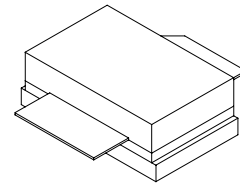

Package Type 440134

PN: UPF1080P

Maximum Ratings

Rating	Symbol	Value	Unit
Drain to Source Voltage, gate connected to source	BV_{DSS}	65	Volts
Gate to Source Voltage	BV_{GSS}	+/- 20	Volts
Total Device Dissipation @ $T_{case} = 70^{\circ}C$ Derate above $70^{\circ}C$	P_D	118 0.9	Watts $W/^{\circ}C$
Storage Temperature Range	T_{STG}	-65 to +150	$^{\circ}C$
Operating Junction Temperature	T_J	200	$^{\circ}C$

www.DataSheet4U.com

Thermal Characteristics

Characteristics	Symbol	Typical	Unit
Thermal Resistance, Junction to Case	θ_{jc}	1.1	$^{\circ}C/W$

Electrical DC Characteristics ($T_C = 25^{\circ}C$ unless otherwise specified)

Rating	Symbol	Min	Typ	Max	Unit
Drain to Source Voltage, gate connected to source ($V_{GS} = 0, I_{DS} = 1mA$)	BV_{DSS}	65	-	-	Volts
Drain to Source Leakage current ($V_{DS} = 28V, V_{GS} = 0$)	I_{DSS}	-	-	1.0	mA
Gate to Source Leakage current ($V_{GS} = 20V, V_{DS} = 0$)	I_{GSS}	-	-	1.0	μA
Threshold Voltage ($V_{DS} = 10V, I_{DS} = 1mA$)	V_{TH}	2.0	3.1	5.0	Volts
Gate Quiescent Voltage ($V_{DS} = 26V, I_{DS} = 500mA$)	$V_{GS(on)}$	3.0	4.0	6.0	Volts
Drain to Source On Voltage ($V_{GS} = 10V, I_{DS} = 1A$)	$V_{DS(on)}$	-	0.13	-	Volts
Forward Transconductance ($V_{DS} = 10V, I_D = 5A$)	G_M	2.0	3.0	-	S

AC Characteristics (T_C=25°C unless otherwise specified)

Rating	Symbol	Min	Typ	Max	Unit
Input Capacitance (V _{DS} =26V, V _{GS} =0V, freq= 1MHz)	C _{ISS}	-	-	-	pF
Output capacitance (V _{DS} = 26V, V _{GS} =0V, freq= 1MHz)	C _{OSS}	-	58	-	pF
Feedback capacitance (V _{DS} =26V, V _{GS} =0V, freq= 1MHz)	C _{RSS}	-	3.8	-	pF

www.DataSheet4U.com

RF and Functional Tests (T_C=25°C unless otherwise specified, Cree Microwave Broadband Fixture)

Rating	Symbol	Min	Typ	Max	Unit
Linear Power Gain, Single Tone (V _{DS} =26V, I _{DQ} =600mA, P _{OUT} =10W, f=894 MHz)	G _L	9.5	10.5	-	dB
Compressed Power Gain, Single Tone (V _{DS} =26V, I _{DQ} =600mA, P _{OUT} =80W, f=894 MHz)	G _P	9.0	10.0	-	dB
Drain Efficiency, Single Tone (V _{DS} =26V, I _{DQ} =600mA, P _{OUT} =80W, f=894 MHz)	η _D	45	52	-	%
Intermodulation Distortion, Two Tone (V _{DS} =26V, I _{DQ} =600mA, P _{OUT} =80W PEP f1=864 MHz, f2=894.1MHz)	IMD	-	-32	-30	dBc
Load Mismatch Tolerance (V _{DS} =26V, I _{DQ} =600mA, P _{OUT} =80W, f=894 MHz)	VSWR*	10:1	-	-	Ψ

Note (unless otherwise specified):

1. Source and load impedance shall be 50 ohms.

*No degradation in device performance after test.

CAUTION - MOS Devices are susceptible to damage from Electrostatic Discharge (ESD). Appropriate precautions in handling, packaging and testing MOS devices must be observed.

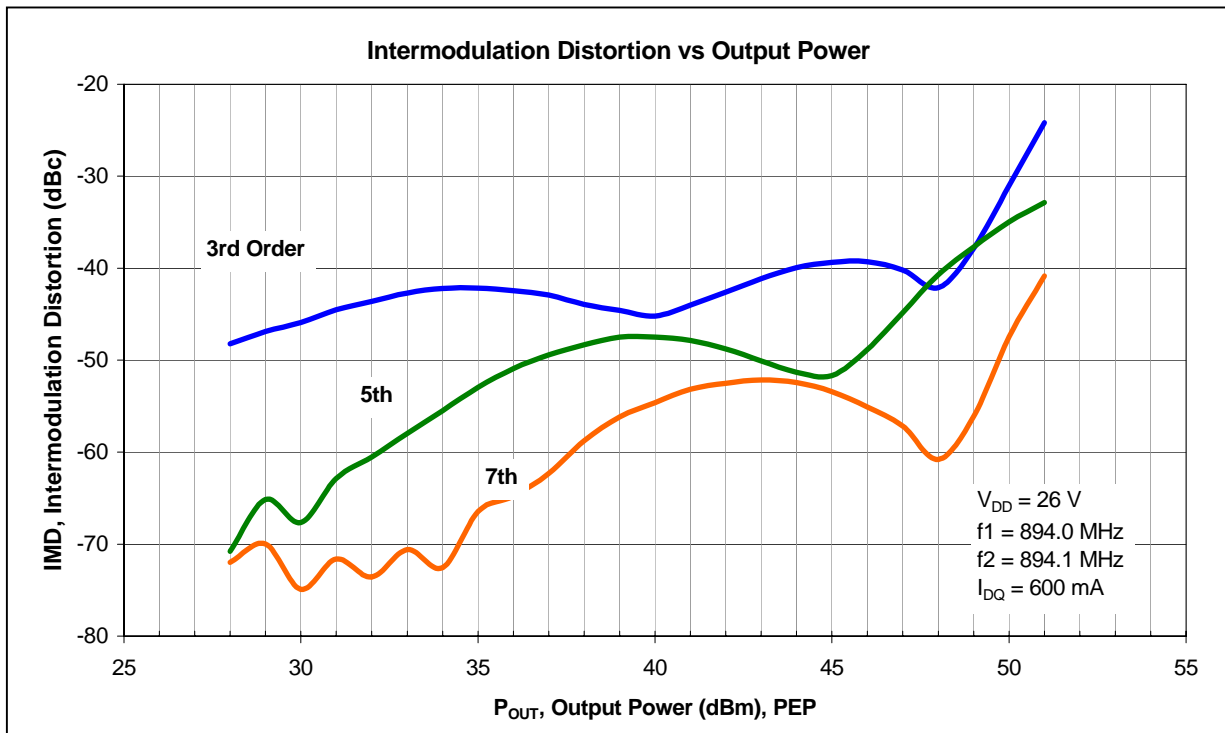
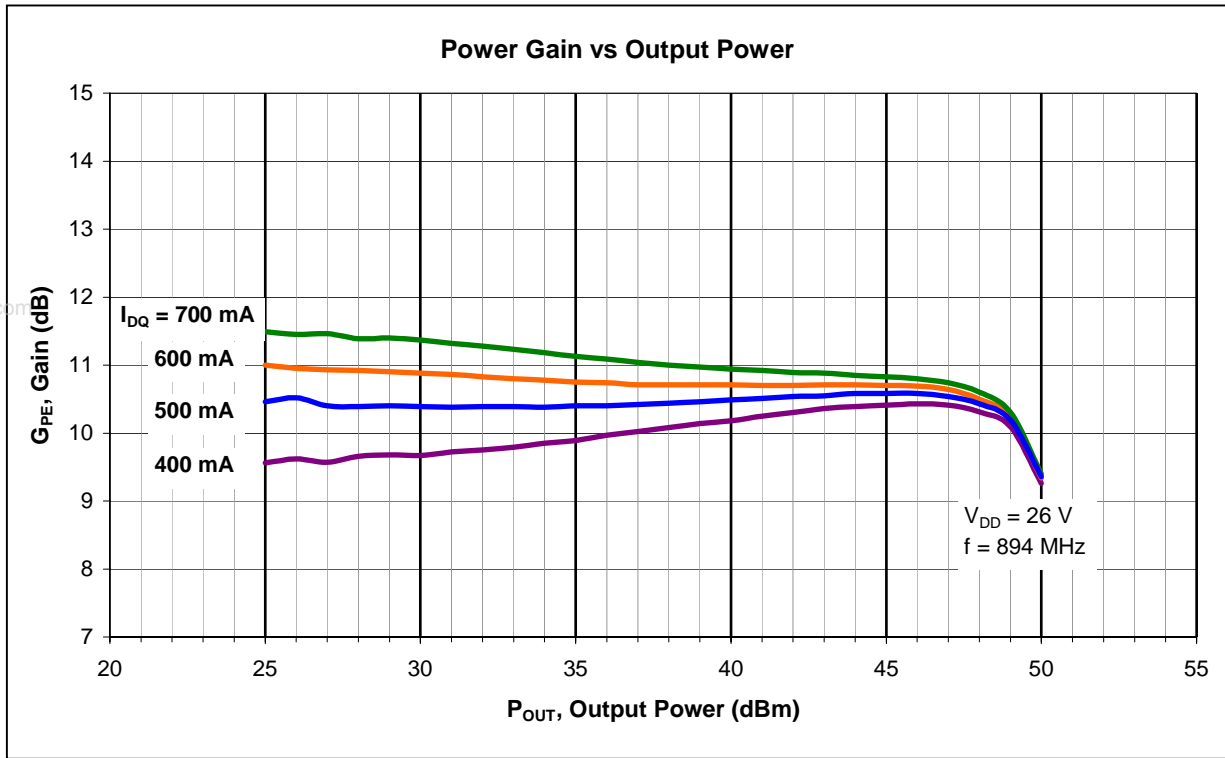

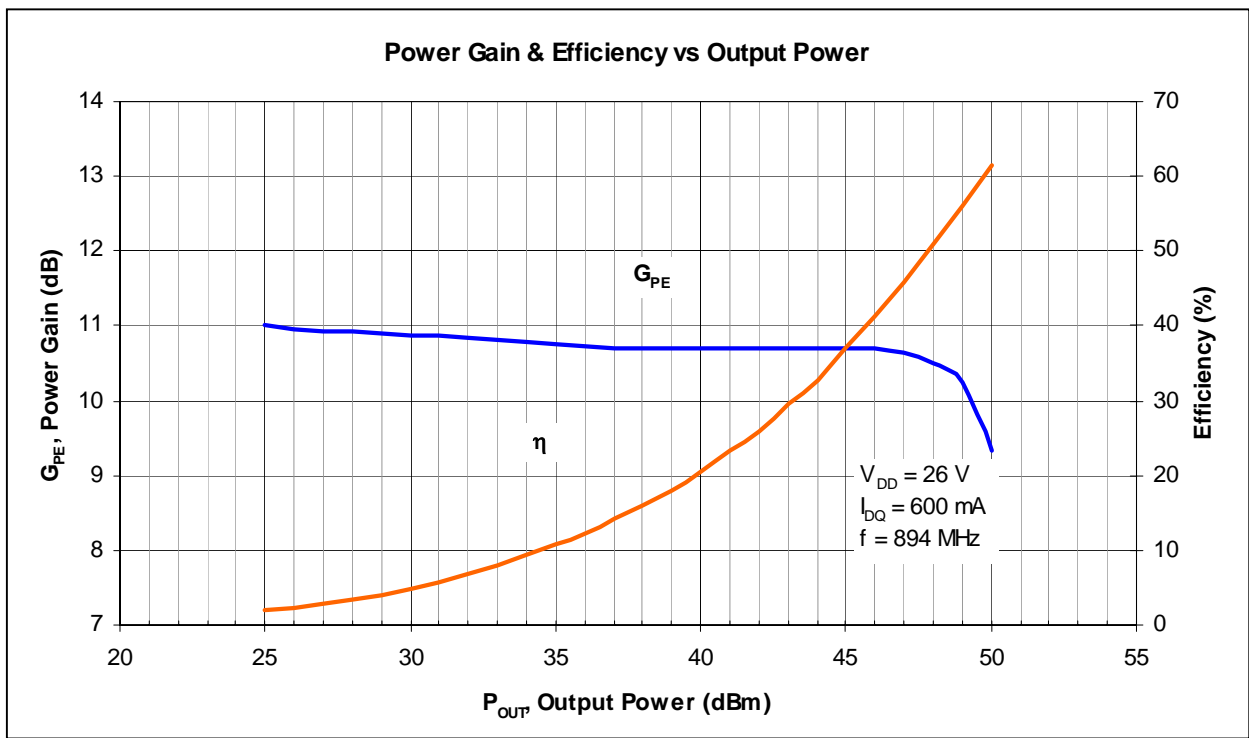
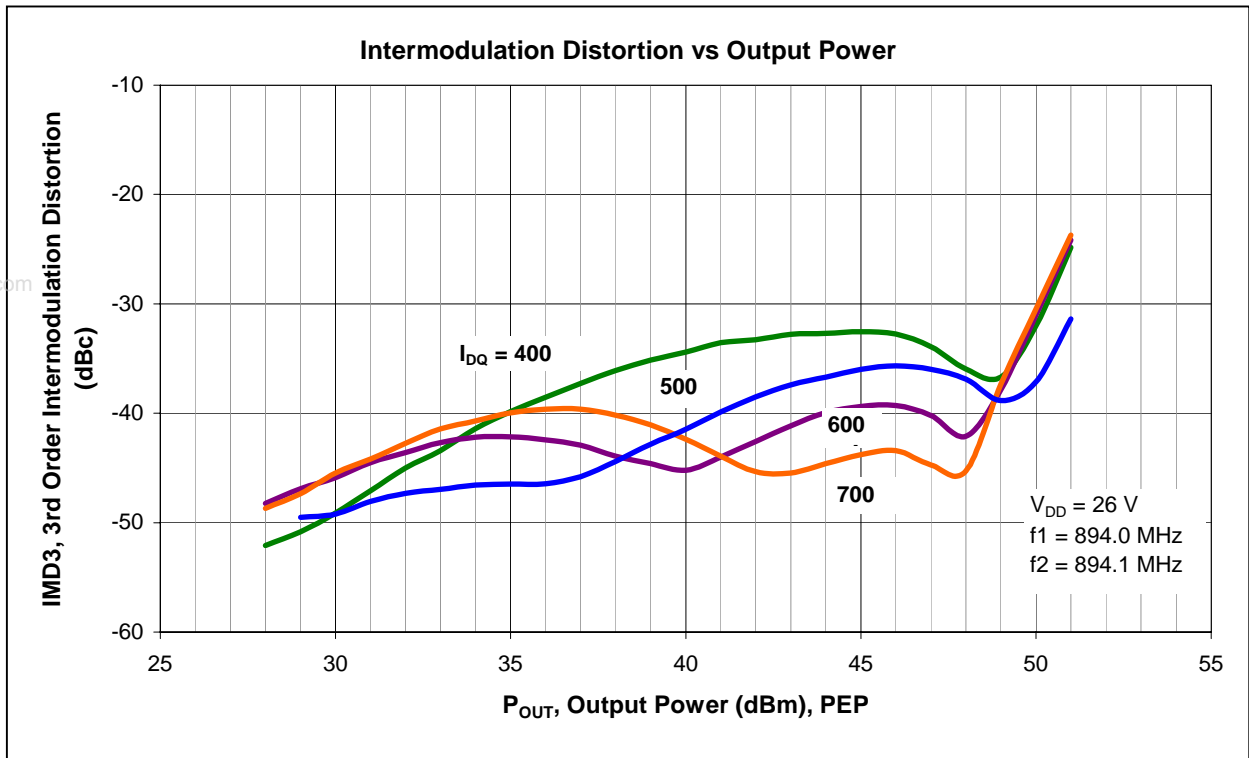

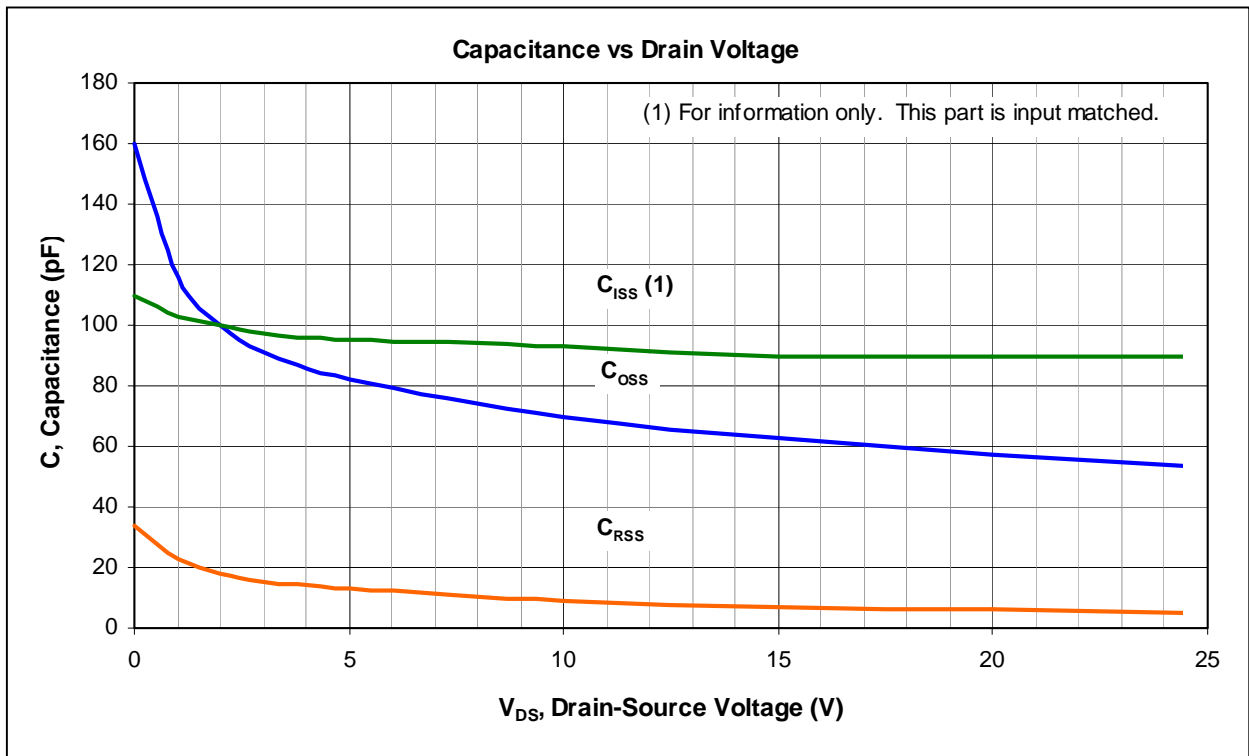
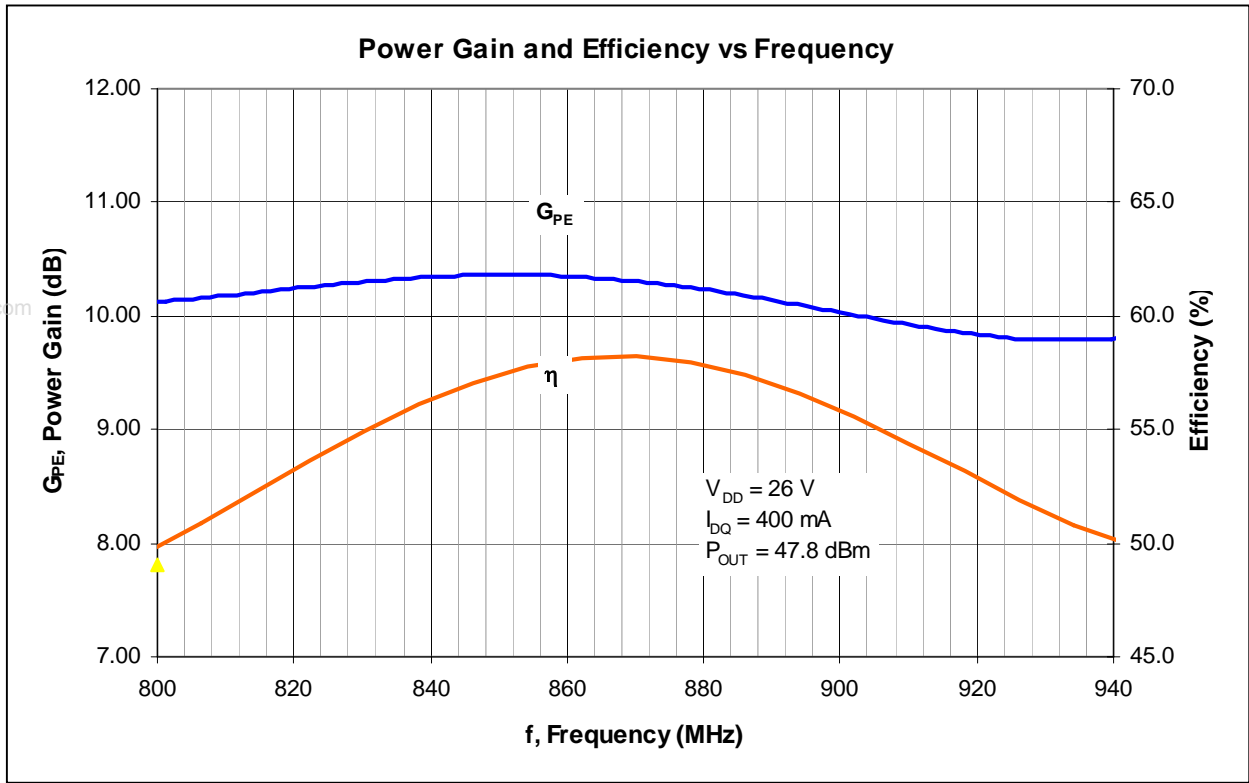

www.DataSheet4U.com

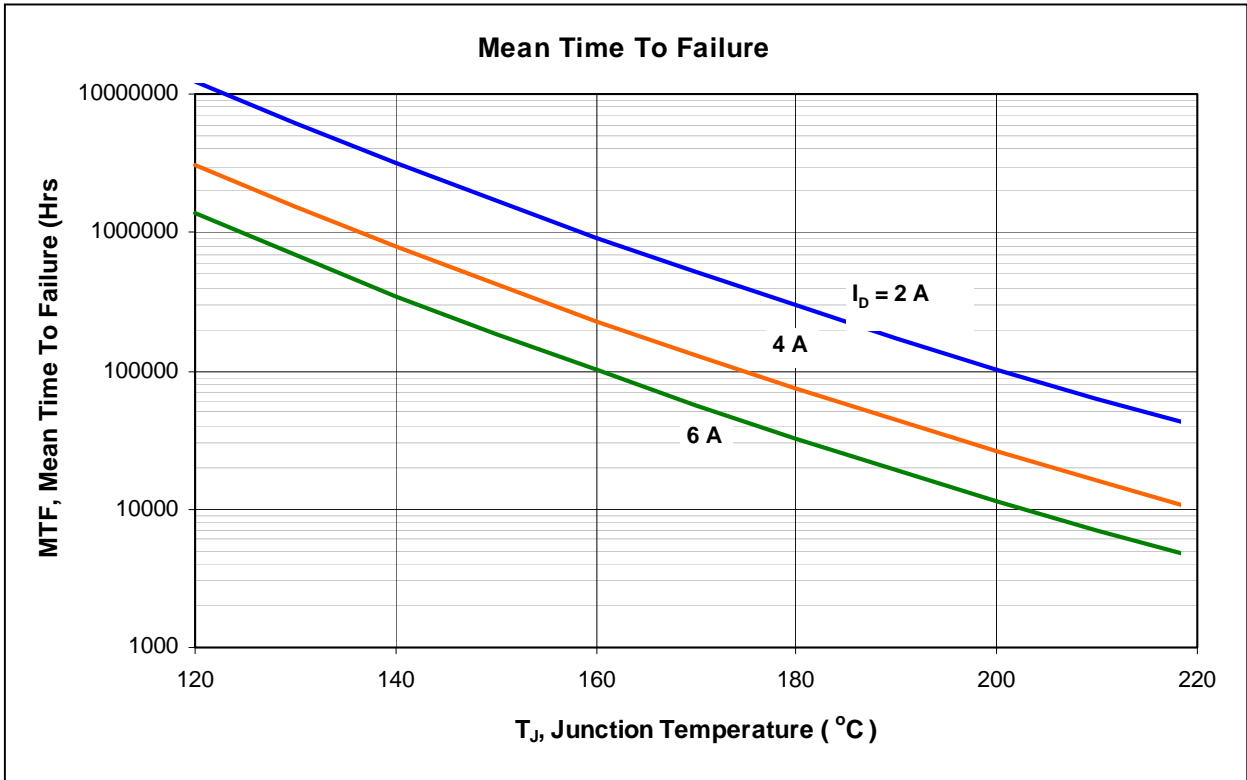
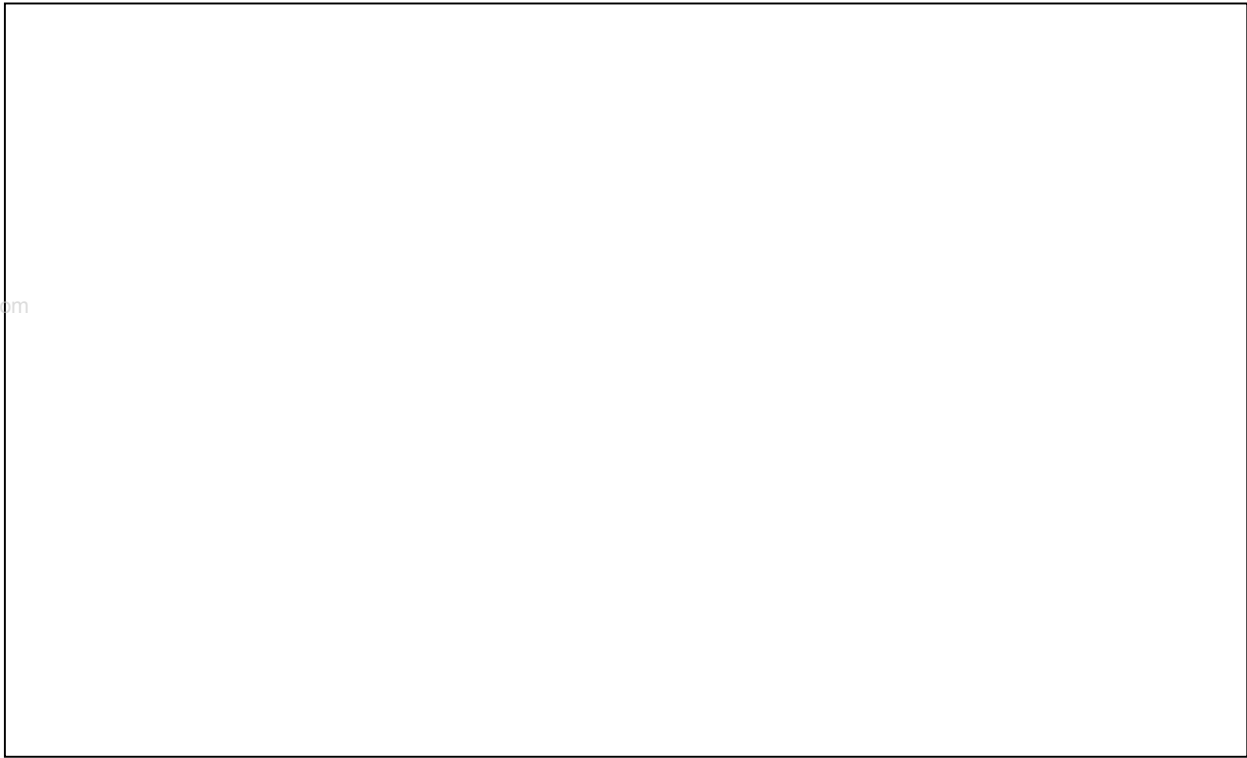

Impedance

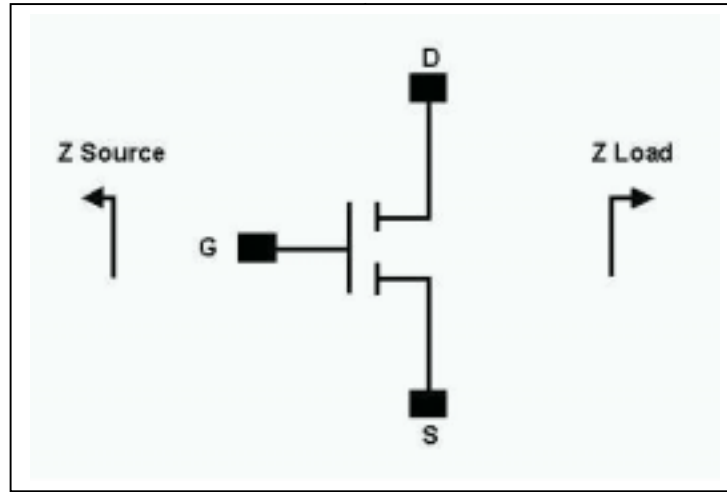

www.DataSheet4U.com

Frequency (MHz)	Z Source	Z Load
850	0.45 – j1.10	1.47 + j0.27
860	0.46 – j1.12	1.52 + j0.31
870	0.48 – j1.14	1.60 + j0.34
880	0.49 – j1.16	1.68 + j0.36
890	0.51 – j1.18	1.79 + j0.36
900	0.52 – j1.20	1.87 + j0.36

Note: $V_{DD} = 26V$, $I_{DQ} = 600mA$

Test Fixture Layout

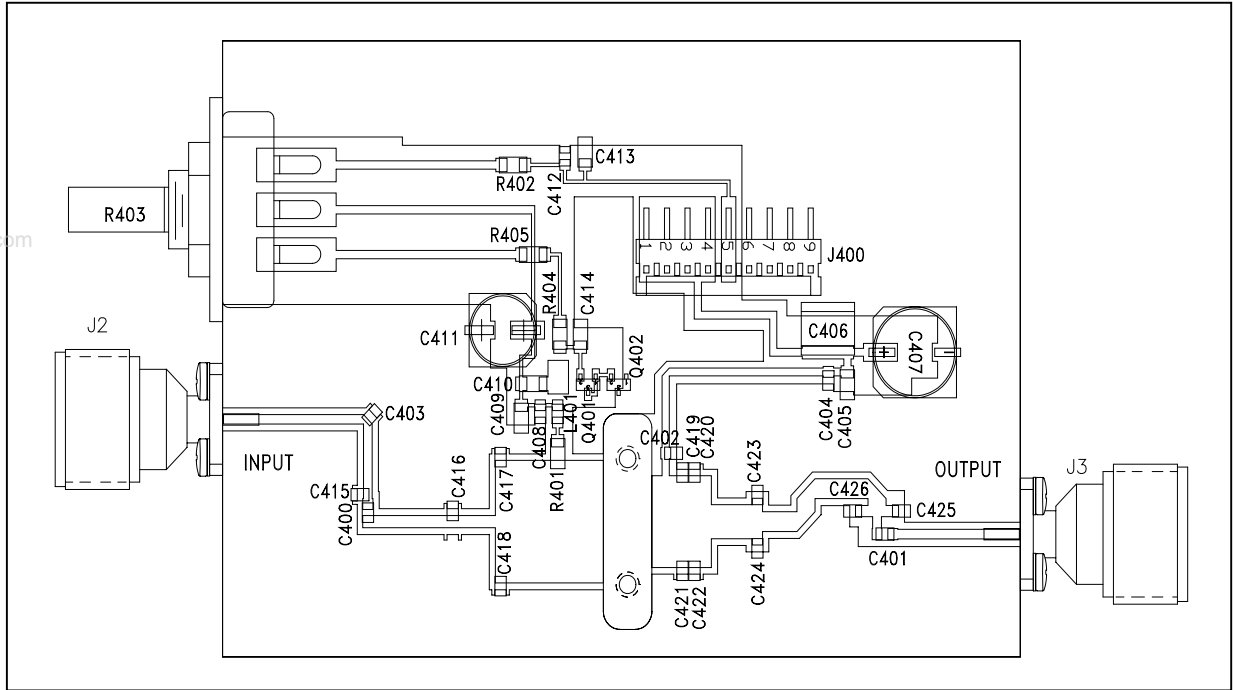

Test Fixture Schematic

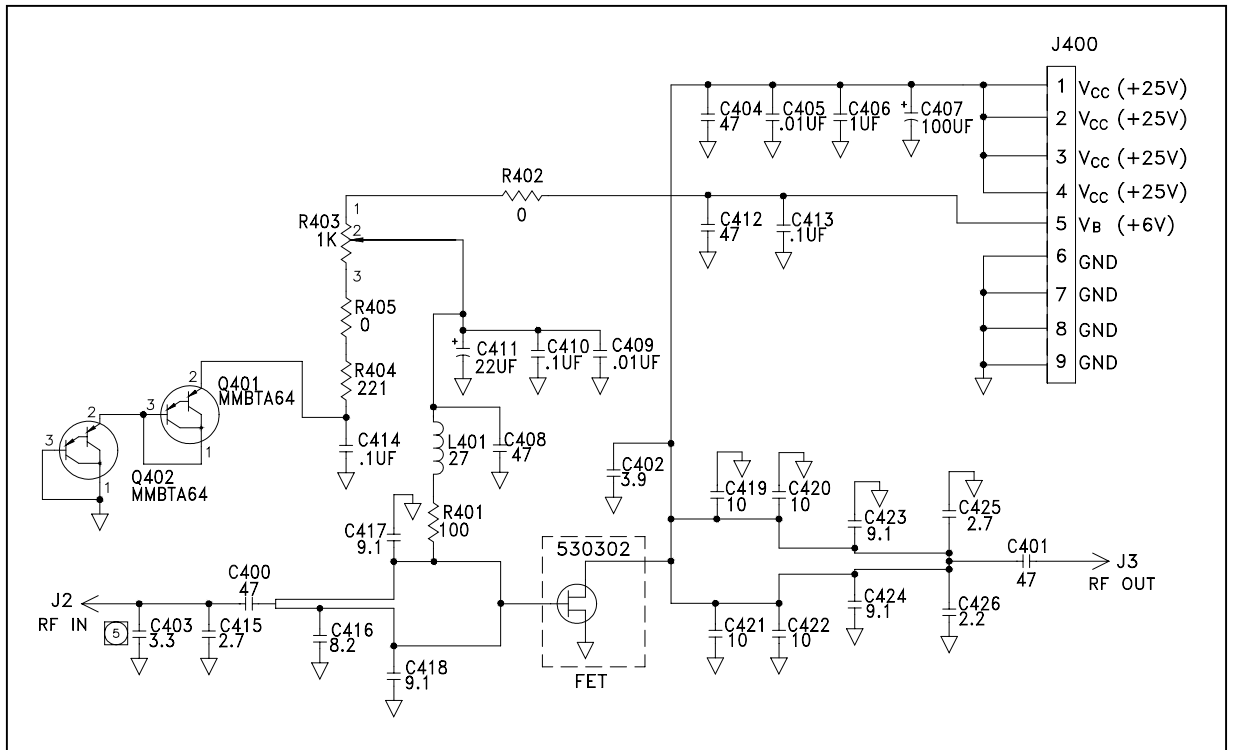

Product Dimensions

UPF1080F -Package Number 440095

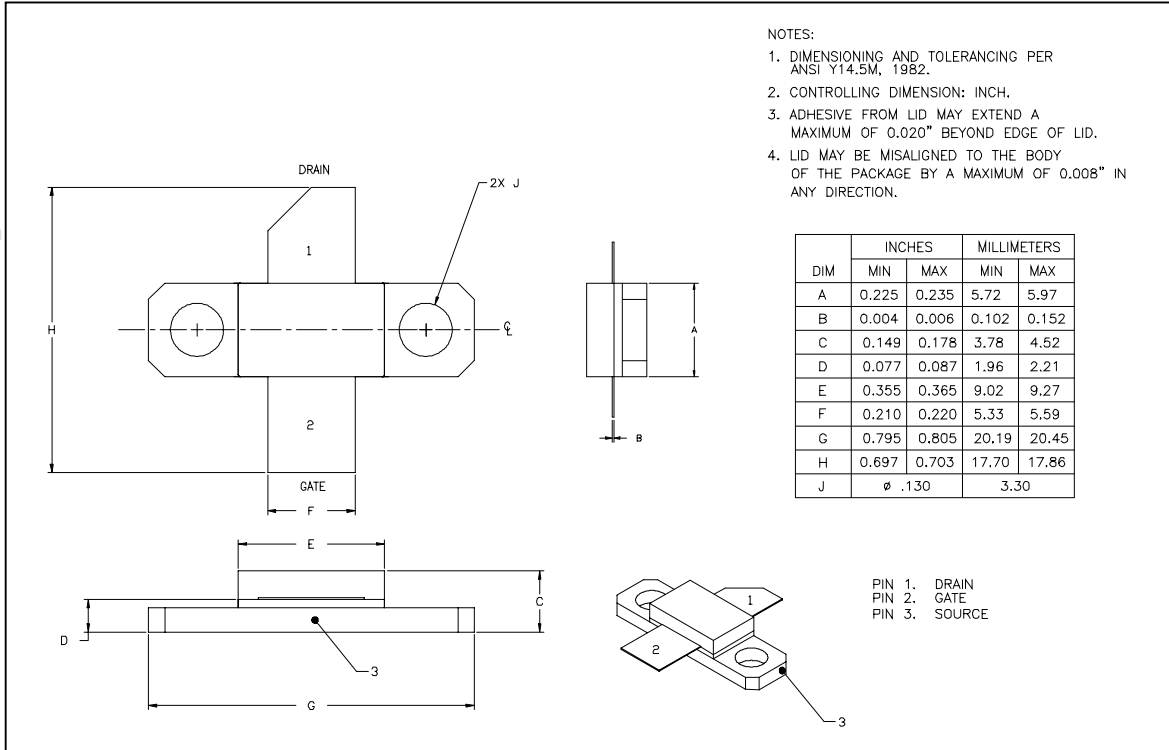

UPF1080P -Package Number 440134

