



UR56XX1

Preliminary

CMOS IC

18-V INPUT VOLTAGE 500MA ULTRA LOW IQ VOLTAGE REGULATOR

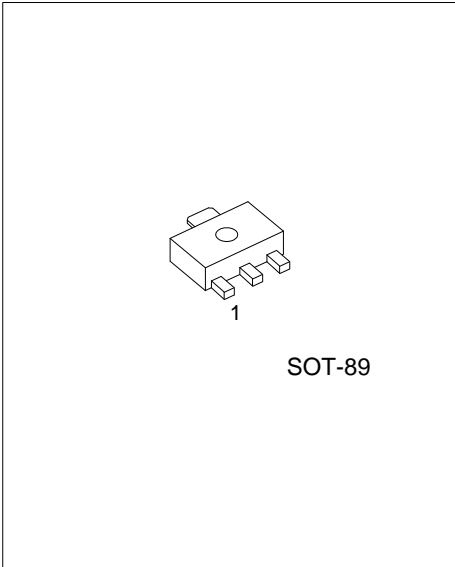

DESCRIPTION

The UTC UR56XX1 Series are a low dropout regulator with wide input voltage range, high output voltage accuracy, ultra low quiescent current and low dropout. This regulator is based on a CMOS process, and it's input voltage could high enough more than 18V, thus they are very suitable for high voltage application.

FEATURES

- * High output voltage accuracy: $\pm 2\%$
- * Ultra low quiescent current: 1.0uA (Typ.)
- * Low temperature-drift coefficient of V_{OUT} : $\pm 100\text{ppm}/^\circ\text{C}$ (Typ.)
- * Wide Input voltage range: 0~18V

ORDERING INFORMATION

Ordering Number		Package	Pin Assignment			Packing
Lead Free	Halogen Free		1	2	3	
UR56XX1L-AB3-R	UR56XX1G-AB3-R	SOT-89	O	G	I	Tape Reel

Note: Pin assignment: G: Ground I: V_{IN} O: V_{OUT}

<p>UR56XX1G-AB3-R</p> <p>(1) Packing Type (2) Package Type (4) Green Package (5) Output Voltage Code</p>	<p>(1) R: Tape Reel (2) AB3: SOT-89 (4) G: Halogen Free and Lead Free, L: Lead Free (5) XX: Refer to Marking Information</p>
--	--

MARKING INFORMATION

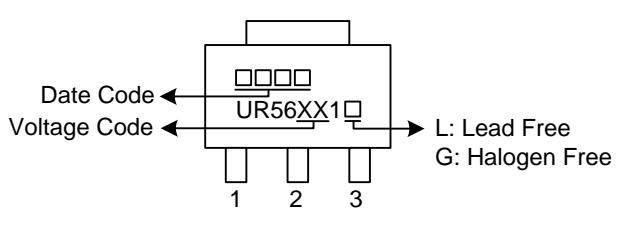
PACKAGE	VOLTAGE CODE	MARKING
SOT-89	15:1.5V	 <p>Date Code Voltage Code</p> <p>UR56XX1</p> <p>1 2 3</p> <p>L: Lead Free G: Halogen Free</p>
	18:1.8V	
	21:2.1V	
	23:2.3V	
	25:2.5V	
	27:2.7V	
	30:3.0V	
	33:3.3V	
	36:3.6V	
	40:4.0V	
	44:4.4V	
	50:5.0V	
	60:6.0V	
	70:7.0V	
80:8.0V		
90:9.0V		
10:10V		
12:12V		

PIN DESCRIPTION

PIN NO.	PIN NAME	DESCRIPTION
1	V_{OUT}	Regulated output voltage
2	GND	Ground
3	V_{IN}	Input voltage.

BLOCK DIAGRAM

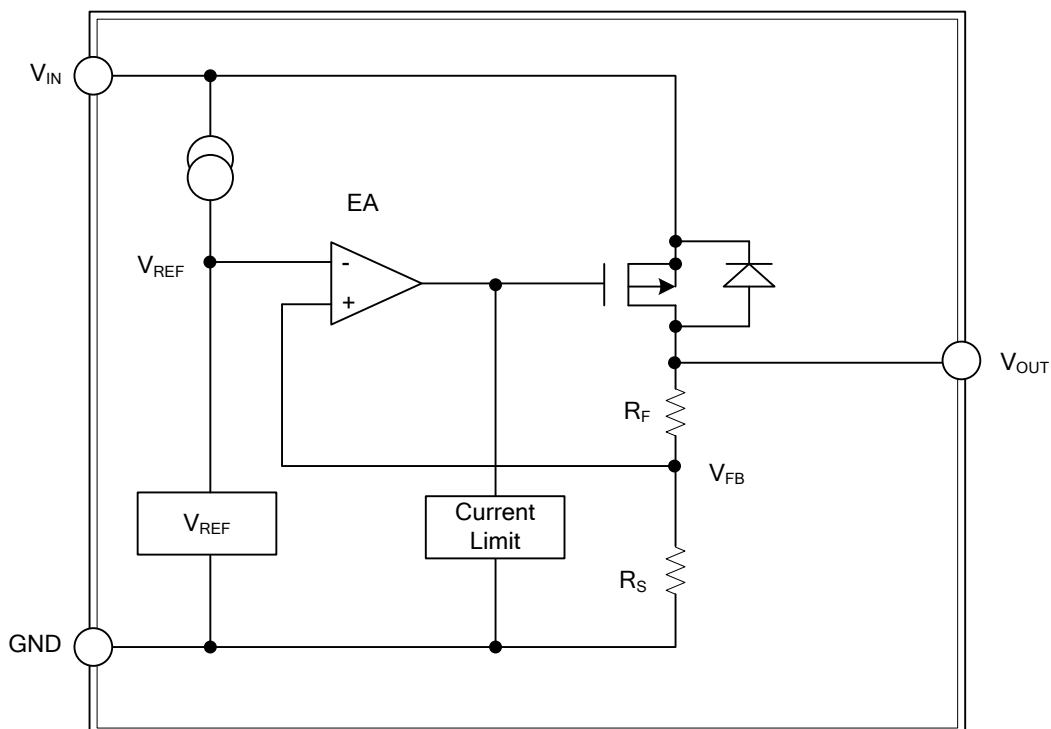

■ ABSOLUTE MAXIMUM RATING

PARAMETER	SYMBOL	RATINGS	UNIT
Input Voltage	V_{IN}	18	V
Output Voltage	V_{OUT}	12	V
Power Dissipation	P_D	500	mW
Operating Temperature Range	T_{OPR}	-40 ~ +85	°C
Storage Temperature Range	T_{STG}	-40 ~ +125	°C

Note: Absolute maximum ratings are those values beyond which the device could be permanently damaged. Absolute maximum ratings are stress ratings only and functional device operation is not implied.

■ ELECTRICAL CHARACTERISTICS ($T_A=25^\circ\text{C}$, unless otherwise specified)

UTC UR56151

PARAMETER	SYMBOL	TEST CONDITIONS	MIN	TYP	MAX	UNIT
Output Voltage	V_{OUT}	$V_{IN}=V_{OUT}+2V, I_{OUT}=10\text{mA}$	1.47	1.5	1.53	V
Output Current (Note 1)	I_{OUT}	$V_{IN}=V_{OUT}+2V$	500			mA
Dropout Voltage (Note 2)	V_{DROP}	$I_{OUT}=60\text{mA}$		100	150	mV
Line Regulation	$\frac{\Delta V_{OUT1}}{\Delta V_{IN} \cdot V_{OUT}}$	$V_{OUT}+2V \leq V_{IN} \leq 16V, I_{OUT}=1\text{mA}$		0.05	0.2	%/V
Load Regulation	ΔV_{OUT2}	$V_{IN}=V_{OUT}+2V, 1.0\text{mA} \leq I_{OUT} \leq 100\text{mA}$		30	80	mV
Output Voltage Temperature Coefficient	$\frac{\Delta V_{OUT1}}{T_A \cdot V_{OUT}}$	$V_{IN}=V_{OUT}+2V, I_{OUT}=10\text{mA}, -40^\circ\text{C} \leq T_A \leq 85^\circ\text{C}$		± 100		ppm/°C
Supply Current	I_{SS1}	$V_{IN}=V_{OUT}+2V$		1.0	3.0	uA

UTC UR56181

PARAMETER	SYMBOL	TEST CONDITIONS	MIN	TYP	MAX	UNIT
Output Voltage	V_{OUT}	$V_{IN}=V_{OUT}+2V, I_{OUT}=10\text{mA}$	1.764	1.8	1.836	V
Output Current (Note 1)	I_{OUT}	$V_{IN}=V_{OUT}+2V$	500			mA
Dropout Voltage (Note 2)	V_{DROP}	$I_{OUT}=60\text{mA}$		100	150	mV
Line Regulation	$\frac{\Delta V_{OUT1}}{\Delta V_{IN} \cdot V_{OUT}}$	$V_{OUT}+2V \leq V_{IN} \leq 16V, I_{OUT}=1\text{mA}$		0.05	0.2	%/V
Load Regulation	ΔV_{OUT2}	$V_{IN}=V_{OUT}+2V, 1.0\text{mA} \leq I_{OUT} \leq 100\text{mA}$		30	80	mV
Output Voltage Temperature Coefficient	$\frac{\Delta V_{OUT1}}{T_A \cdot V_{OUT}}$	$V_{IN}=V_{OUT}+2V, I_{OUT}=10\text{mA}, -40^\circ\text{C} \leq T_A \leq 85^\circ\text{C}$		± 100		ppm/°C
Supply Current	I_{SS1}	$V_{IN}=V_{OUT}+2V$		1.0	3.0	uA

UTC UR56211

PARAMETER	SYMBOL	TEST CONDITIONS	MIN	TYP	MAX	UNIT
Output Voltage	V_{OUT}	$V_{IN}=V_{OUT}+2V, I_{OUT}=10\text{mA}$	2.058	2.1	2.142	V
Output Current (Note 1)	I_{OUT}	$V_{IN}=V_{OUT}+2V$	500			mA
Dropout Voltage (Note 2)	V_{DROP}	$I_{OUT}=80\text{mA}$		120	150	mV
Line Regulation	$\frac{\Delta V_{OUT1}}{\Delta V_{IN} \cdot V_{OUT}}$	$V_{OUT}+2V \leq V_{IN} \leq 16V, I_{OUT}=1\text{mA}$		0.05	0.2	%/V
Load Regulation	ΔV_{OUT2}	$V_{IN}=V_{OUT}+2V, 1.0\text{mA} \leq I_{OUT} \leq 100\text{mA}$		30	80	mV
Output Voltage Temperature Coefficient	$\frac{\Delta V_{OUT1}}{T_A \cdot V_{OUT}}$	$V_{IN}=V_{OUT}+2V, I_{OUT}=10\text{mA}, -40^\circ\text{C} \leq T_A \leq 85^\circ\text{C}$		± 100		ppm/°C
Supply Current	I_{SS1}	$V_{IN}=V_{OUT}+2V$		1.0	3.0	uA

■ ELECTRICAL CHARACTERISTICS (Cont.)

UTC UR56231

PARAMETER	SYMBOL	TEST CONDITIONS	MIN	TYP	MAX	UNIT
Output Voltage	V_{OUT}	$V_{IN}=V_{OUT}+2V, I_{OUT}=10mA$	2.254	2.3	2.346	V
Output Current (Note 1)	I_{OUT}	$V_{IN}=V_{OUT}+2V$	500			mA
Dropout Voltage (Note 2)	V_{DROP}	$I_{OUT}=80mA$		120	150	mV
Line Regulation	$\frac{\Delta V_{OUT1}}{\Delta V_{IN} \cdot V_{OUT}}$	$V_{OUT}+2V \leq V_{IN} \leq 16V, I_{OUT}=1mA$		0.05	0.2	%/V
Load Regulation	ΔV_{OUT2}	$V_{IN}=V_{OUT}+2V, 1.0mA \leq I_{OUT} \leq 100mA$		30	80	mV
Output Voltage Temperature Coefficient	$\frac{\Delta V_{OUT1}}{T_A \cdot V_{OUT}}$	$V_{IN}=V_{OUT}+2V, I_{OUT}=10mA, -40^\circ C \leq T_A \leq 85^\circ C$		± 100		ppm/ $^\circ C$
Supply Current	I_{SS1}	$V_{IN}=V_{OUT}+2V$		1.0	3.0	μA

UTC UR56251

PARAMETER	SYMBOL	TEST CONDITIONS	MIN	TYP	MAX	UNIT
Output Voltage	V_{OUT}	$V_{IN}=V_{OUT}+2V, I_{OUT}=10mA$	2.45	2.5	2.55	V
Output Current (Note 1)	I_{OUT}	$V_{IN}=V_{OUT}+2V$	500			mA
Dropout Voltage (Note 2)	V_{DROP}	$I_{OUT}=80mA$		120	150	mV
Line Regulation	$\frac{\Delta V_{OUT1}}{\Delta V_{IN} \cdot V_{OUT}}$	$V_{OUT}+2V \leq V_{IN} \leq 16V, I_{OUT}=1mA$		0.05	0.2	%/V
Load Regulation	ΔV_{OUT2}	$V_{IN}=V_{OUT}+2V, 1.0mA \leq I_{OUT} \leq 100mA$		30	80	mV
Output Voltage Temperature Coefficient	$\frac{\Delta V_{OUT1}}{T_A \cdot V_{OUT}}$	$V_{IN}=V_{OUT}+2V, I_{OUT}=10mA, -40^\circ C \leq T_A \leq 85^\circ C$		± 100		ppm/ $^\circ C$
Supply Current	I_{SS1}	$V_{IN}=V_{OUT}+2V$		1.0	3.0	μA

UTC UR56271

PARAMETER	SYMBOL	TEST CONDITIONS	MIN	TYP	MAX	UNIT
Output Voltage	V_{OUT}	$V_{IN}=V_{OUT}+2V, I_{OUT}=10mA$	2.646	2.7	2.754	V
Output Current (Note 1)	I_{OUT}	$V_{IN}=V_{OUT}+2V$	500			mA
Dropout Voltage (Note 2)	V_{DROP}	$I_{OUT}=80mA$		120	150	mV
Line Regulation	$\frac{\Delta V_{OUT1}}{\Delta V_{IN} \cdot V_{OUT}}$	$V_{OUT}+2V \leq V_{IN} \leq 16V, I_{OUT}=1mA$		0.05	0.2	%/V
Load Regulation	ΔV_{OUT2}	$V_{IN}=V_{OUT}+2V, 1.0mA \leq I_{OUT} \leq 100mA$		30	80	mV
Output Voltage Temperature Coefficient	$\frac{\Delta V_{OUT1}}{T_A \cdot V_{OUT}}$	$V_{IN}=V_{OUT}+2V, I_{OUT}=10mA, -40^\circ C \leq T_A \leq 85^\circ C$		± 100		ppm/ $^\circ C$
Supply Current	I_{SS1}	$V_{IN}=V_{OUT}+2V$		1.0	3.0	μA

UTC UR56301

PARAMETER	SYMBOL	TEST CONDITIONS	MIN	TYP	MAX	UNIT
Output Voltage	V_{OUT}	$V_{IN}=V_{OUT}+2V, I_{OUT}=10mA$	2.94	3.0	3.06	V
Output Current (Note 1)	I_{OUT}	$V_{IN}=V_{OUT}+2V$	500			mA
Dropout Voltage (Note 2)	V_{DROP}	$I_{OUT}=80mA$		120	150	mV
Line Regulation	$\frac{\Delta V_{OUT1}}{\Delta V_{IN} \cdot V_{OUT}}$	$V_{OUT}+2V \leq V_{IN} \leq 16V, I_{OUT}=1mA$		0.05	0.2	%/V
Load Regulation	ΔV_{OUT2}	$V_{IN}=V_{OUT}+2V, 1.0mA \leq I_{OUT} \leq 100mA$		30	80	mV
Output Voltage Temperature Coefficient	$\frac{\Delta V_{OUT1}}{T_A \cdot V_{OUT}}$	$V_{IN}=V_{OUT}+2V, I_{OUT}=10mA, -40^\circ C \leq T_A \leq 85^\circ C$		± 100		ppm/ $^\circ C$
Supply Current	I_{SS1}	$V_{IN}=V_{OUT}+2V$		1.0	3.0	μA

■ ELECTRICAL CHARACTERISTICS (Cont.)

UTC UR56331

PARAMETER	SYMBOL	TEST CONDITIONS	MIN	TYP	MAX	UNIT
Output Voltage	V_{OUT}	$V_{IN}=V_{OUT}+2V, I_{OUT}=10mA$	3.234	3.3	3.366	V
Output Current (Note 1)	I_{OUT}	$V_{IN}=V_{OUT}+2V$	500			mA
Dropout Voltage (Note 2)	V_{DROP}	$I_{OUT}=100mA$		160	200	mV
Line Regulation	$\frac{\Delta V_{OUT1}}{\Delta V_{IN} \cdot V_{OUT}}$	$V_{OUT}+2V \leq V_{IN} \leq 16V, I_{OUT}=1mA$		0.05	0.2	%/V
Load Regulation	ΔV_{OUT2}	$V_{IN}=V_{OUT}+2V, 1.0mA \leq I_{OUT} \leq 100mA$		30	80	mV
Output Voltage Temperature Coefficient	$\frac{\Delta V_{OUT1}}{T_A \cdot V_{OUT}}$	$V_{IN}=V_{OUT}+2V, I_{OUT}=10mA, -40^\circ C \leq T_A \leq 85^\circ C$		± 100		ppm/ $^\circ C$
Supply Current	I_{SS1}	$V_{IN}=V_{OUT}+2V$		1.0	3.0	μA

UTC UR56361

PARAMETER	SYMBOL	TEST CONDITIONS	MIN	TYP	MAX	UNIT
Output Voltage	V_{OUT}	$V_{IN}=V_{OUT}+2V, I_{OUT}=10mA$	3.528	3.6	3.672	V
Output Current (Note 1)	I_{OUT}	$V_{IN}=V_{OUT}+2V$	500			mA
Dropout Voltage (Note 2)	V_{DROP}	$I_{OUT}=100mA$		160	200	mV
Line Regulation	$\frac{\Delta V_{OUT1}}{\Delta V_{IN} \cdot V_{OUT}}$	$V_{OUT}+2V \leq V_{IN} \leq 16V, I_{OUT}=1mA$		0.05	0.2	%/V
Load Regulation	ΔV_{OUT2}	$V_{IN}=V_{OUT}+2V, 1.0mA \leq I_{OUT} \leq 100mA$		30	80	mV
Output Voltage Temperature Coefficient	$\frac{\Delta V_{OUT1}}{T_A \cdot V_{OUT}}$	$V_{IN}=V_{OUT}+2V, I_{OUT}=10mA, -40^\circ C \leq T_A \leq 85^\circ C$		± 100		ppm/ $^\circ C$
Supply Current	I_{SS1}	$V_{IN}=V_{OUT}+2V$		1.0	3.0	μA

UTC UR56401

PARAMETER	SYMBOL	TEST CONDITIONS	MIN	TYP	MAX	UNIT
Output Voltage	V_{OUT}	$V_{IN}=V_{OUT}+2V, I_{OUT}=10mA$	3.92	4.0	4.08	V
Output Current (Note 1)	I_{OUT}	$V_{IN}=V_{OUT}+2V$	500			mA
Dropout Voltage (Note 2)	V_{DROP}	$I_{OUT}=100mA$		160	200	mV
Line Regulation	$\frac{\Delta V_{OUT1}}{\Delta V_{IN} \cdot V_{OUT}}$	$V_{OUT}+2V \leq V_{IN} \leq 16V, I_{OUT}=1mA$		0.05	0.2	%/V
Load Regulation	ΔV_{OUT2}	$V_{IN}=V_{OUT}+2V, 1.0mA \leq I_{OUT} \leq 100mA$		30	80	mV
Output Voltage Temperature Coefficient	$\frac{\Delta V_{OUT1}}{T_A \cdot V_{OUT}}$	$V_{IN}=V_{OUT}+2V, I_{OUT}=10mA, -40^\circ C \leq T_A \leq 85^\circ C$		± 100		ppm/ $^\circ C$
Supply Current	I_{SS1}	$V_{IN}=V_{OUT}+2V$		1.0	3.0	μA

UTC UR56441

PARAMETER	SYMBOL	TEST CONDITIONS	MIN	TYP	MAX	UNIT
Output Voltage	V_{OUT}	$V_{IN}=V_{OUT}+2V, I_{OUT}=10mA$	4.312	4.4	4.488	V
Output Current (Note 1)	I_{OUT}	$V_{IN}=V_{OUT}+2V$	500			mA
Dropout Voltage (Note 2)	V_{DROP}	$I_{OUT}=100mA$		170	200	mV
Line Regulation	$\frac{\Delta V_{OUT1}}{\Delta V_{IN} \cdot V_{OUT}}$	$V_{OUT}+2V \leq V_{IN} \leq 16V, I_{OUT}=1mA$		0.05	0.2	%/V
Load Regulation	ΔV_{OUT2}	$V_{IN}=V_{OUT}+2V, 1.0mA \leq I_{OUT} \leq 100mA$		30	80	mV
Output Voltage Temperature Coefficient	$\frac{\Delta V_{OUT1}}{T_A \cdot V_{OUT}}$	$V_{IN}=V_{OUT}+2V, I_{OUT}=10mA, -40^\circ C \leq T_A \leq 85^\circ C$		± 100		ppm/ $^\circ C$
Supply Current	I_{SS1}	$V_{IN}=V_{OUT}+2V$		1.0	3.0	μA

■ ELECTRICAL CHARACTERISTICS (Cont.)

UTC UR56501

PARAMETER	SYMBOL	TEST CONDITIONS	MIN	TYP	MAX	UNIT
Output Voltage	V_{OUT}	$V_{IN}=V_{OUT}+2V, I_{OUT}=10mA$	4.9	5.0	5.1	V
Output Current (Note 1)	I_{OUT}	$V_{IN}=V_{OUT}+2V$	500			mA
Dropout Voltage (Note 2)	V_{DROP}	$I_{OUT}=100mA$		170	200	mV
Line Regulation	$\frac{\Delta V_{OUT1}}{\Delta V_{IN} \cdot V_{OUT}}$	$V_{OUT}+2V \leq V_{IN} \leq 16V, I_{OUT}=1mA$		0.05	0.2	%/V
Load Regulation	ΔV_{OUT2}	$V_{IN}=V_{OUT}+2V, 1.0mA \leq I_{OUT} \leq 100mA$		30	80	mV
Output Voltage Temperature Coefficient	$\frac{\Delta V_{OUT1}}{T_A \cdot V_{OUT}}$	$V_{IN}=V_{OUT}+2V, I_{OUT}=10mA, -40^\circ C \leq T_A \leq 85^\circ C$		± 100		ppm/ $^\circ C$
Supply Current	I_{SS1}	$V_{IN}=V_{OUT}+2V$		1.0	3.0	μA

UTC UR56601

PARAMETER	SYMBOL	TEST CONDITIONS	MIN	TYP	MAX	UNIT
Output Voltage	V_{OUT}	$V_{IN}=V_{OUT}+2V, I_{OUT}=10mA$	5.88	6.0	6.12	V
Output Current (Note 1)	I_{OUT}	$V_{IN}=V_{OUT}+2V$	500			mA
Dropout Voltage (Note 2)	V_{DROP}	$I_{OUT}=200mA$		200	240	mV
Line Regulation	$\frac{\Delta V_{OUT1}}{\Delta V_{IN} \cdot V_{OUT}}$	$V_{OUT}+2V \leq V_{IN} \leq 16V, I_{OUT}=1mA$		0.05	0.2	%/V
Load Regulation	ΔV_{OUT2}	$V_{IN}=V_{OUT}+2V, 1.0mA \leq I_{OUT} \leq 100mA$		30	80	mV
Output Voltage Temperature Coefficient	$\frac{\Delta V_{OUT1}}{T_A \cdot V_{OUT}}$	$V_{IN}=V_{OUT}+2V, I_{OUT}=10mA, -40^\circ C \leq T_A \leq 85^\circ C$		± 100		ppm/ $^\circ C$
Supply Current	I_{SS1}	$V_{IN}=V_{OUT}+2V$		1.0	3.0	μA

UTC UR56701

PARAMETER	SYMBOL	TEST CONDITIONS	MIN	TYP	MAX	UNIT
Output Voltage	V_{OUT}	$V_{IN}=V_{OUT}+2V, I_{OUT}=10mA$	6.86	7.0	7.14	V
Output Current (Note 1)	I_{OUT}	$V_{IN}=V_{OUT}+2V$	500			mA
Dropout Voltage (Note 2)	V_{DROP}	$I_{OUT}=200mA$		200	240	mV
Line Regulation	$\frac{\Delta V_{OUT1}}{\Delta V_{IN} \cdot V_{OUT}}$	$V_{OUT}+2V \leq V_{IN} \leq 16V, I_{OUT}=1mA$		0.05	0.2	%/V
Load Regulation	ΔV_{OUT2}	$V_{IN}=V_{OUT}+2V, 1.0mA \leq I_{OUT} \leq 100mA$		30	80	mV
Output Voltage Temperature Coefficient	$\frac{\Delta V_{OUT1}}{T_A \cdot V_{OUT}}$	$V_{IN}=V_{OUT}+2V, I_{OUT}=10mA, -40^\circ C \leq T_A \leq 85^\circ C$		± 100		ppm/ $^\circ C$
Supply Current	I_{SS1}	$V_{IN}=V_{OUT}+2V$		2.0	5.0	μA

UTC UR56801

PARAMETER	SYMBOL	TEST CONDITIONS	MIN	TYP	MAX	UNIT
Output Voltage	V_{OUT}	$V_{IN}=V_{OUT}+2V, I_{OUT}=10mA$	7.84	8.0	8.16	V
Output Current (Note 1)	I_{OUT}	$V_{IN}=V_{OUT}+2V$	500			mA
Dropout Voltage (Note 2)	V_{DROP}	$I_{OUT}=200mA$		200	240	mV
Line Regulation	$\frac{\Delta V_{OUT1}}{\Delta V_{IN} \cdot V_{OUT}}$	$V_{OUT}+2V \leq V_{IN} \leq 16V, I_{OUT}=1mA$		0.05	0.2	%/V
Load Regulation	ΔV_{OUT2}	$V_{IN}=V_{OUT}+2V, 1.0mA \leq I_{OUT} \leq 100mA$		30	80	mV
Output Voltage Temperature Coefficient	$\frac{\Delta V_{OUT1}}{T_A \cdot V_{OUT}}$	$V_{IN}=V_{OUT}+2V, I_{OUT}=10mA, -40^\circ C \leq T_A \leq 85^\circ C$		± 100		ppm/ $^\circ C$
Supply Current	I_{SS1}	$V_{IN}=V_{OUT}+2V$		2.0	5.0	μA

■ ELECTRICAL CHARACTERISTICS (Cont.)

UTC UR56901

PARAMETER	SYMBOL	TEST CONDITIONS	MIN	TYP	MAX	UNIT
Output Voltage	V_{OUT}	$V_{IN}=V_{OUT}+2V, I_{OUT}=10mA$	8.82	9.0	9.18	V
Output Current (Note 1)	I_{OUT}	$V_{IN}=V_{OUT}+2V$	500			mA
Dropout Voltage (Note 2)	V_{DROP}	$I_{OUT}=200mA$		200	240	mV
Line Regulation	$\frac{\Delta V_{OUT1}}{\Delta V_{IN} \cdot V_{OUT}}$	$V_{OUT}+2V \leq V_{IN} \leq 16V, I_{OUT}=1mA$		0.05	0.2	%/V
Load Regulation	ΔV_{OUT2}	$V_{IN}=V_{OUT}+2V, 1.0mA \leq I_{OUT} \leq 100mA$		30	80	mV
Output Voltage Temperature Coefficient	$\frac{\Delta V_{OUT1}}{T_A \cdot V_{OUT}}$	$V_{IN}=V_{OUT}+2V, I_{OUT}=10mA, -40^\circ C \leq T_A \leq 85^\circ C$		± 100		ppm/ $^\circ C$
Supply Current	I_{SS1}	$V_{IN}=V_{OUT}+2V$		2.0	5.0	μA

UTC UR56101

PARAMETER	SYMBOL	TEST CONDITIONS	MIN	TYP	MAX	UNIT
Output Voltage	V_{OUT}	$V_{IN}=V_{OUT}+2V, I_{OUT}=10mA$	9.8	10.0	10.2	V
Output Current (Note 1)	I_{OUT}	$V_{IN}=V_{OUT}+2V$	500			mA
Dropout Voltage (Note 2)	V_{DROP}	$I_{OUT}=200mA$		200	240	mV
Line Regulation	$\frac{\Delta V_{OUT1}}{\Delta V_{IN} \cdot V_{OUT}}$	$V_{OUT}+2V \leq V_{IN} \leq 16V, I_{OUT}=1mA$		0.05	0.2	%/V
Load Regulation	ΔV_{OUT2}	$V_{IN}=V_{OUT}+2V, 1.0mA \leq I_{OUT} \leq 100mA$		30	80	mV
Output Voltage Temperature Coefficient	$\frac{\Delta V_{OUT1}}{T_A \cdot V_{OUT}}$	$V_{IN}=V_{OUT}+2V, I_{OUT}=10mA, -40^\circ C \leq T_A \leq 85^\circ C$		± 100		ppm/ $^\circ C$
Supply Current	I_{SS1}	$V_{IN}=V_{OUT}+2V$		2.0	5.0	μA

UTC UR56121

PARAMETER	SYMBOL	TEST CONDITIONS	MIN	TYP	MAX	UNIT
Output Voltage	V_{OUT}	$V_{IN}=V_{OUT}+2V, I_{OUT}=10mA$	11.76	12.0	12.24	V
Output Current (Note 1)	I_{OUT}	$V_{IN}=V_{OUT}+2V$	500			mA
Dropout Voltage (Note 2)	V_{DROP}	$I_{OUT}=200mA$		200	240	mV
Line Regulation	$\frac{\Delta V_{OUT1}}{\Delta V_{IN} \cdot V_{OUT}}$	$V_{OUT}+2V \leq V_{IN} \leq 16V, I_{OUT}=1mA$		0.05	0.2	%/V
Load Regulation	ΔV_{OUT2}	$V_{IN}=V_{OUT}+2V, 1.0mA \leq I_{OUT} \leq 100mA$		30	80	mV
Output Voltage Temperature Coefficient	$\frac{\Delta V_{OUT1}}{T_A \cdot V_{OUT}}$	$V_{IN}=V_{OUT}+2V, I_{OUT}=10mA, -40^\circ C \leq T_A \leq 85^\circ C$		± 100		ppm/ $^\circ C$
Supply Current	I_{SS1}	$V_{IN}=V_{OUT}+2V$		2.0	5.0	μA

Notes: 1. Increase the output current slowly, record the current when V_{OUT} decrease 98% of V_{OUT} .

2. $V_{drop}=V_{IN1}-(V_{OUT} \times 0.98)$, $V_{OUT}: V_{IN}=V_{OUT}+2V, I_{OUT}=1mA$

■ TEST CIRCUIT

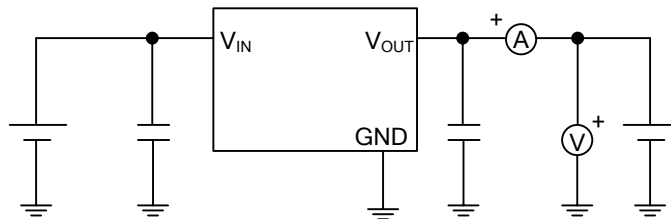
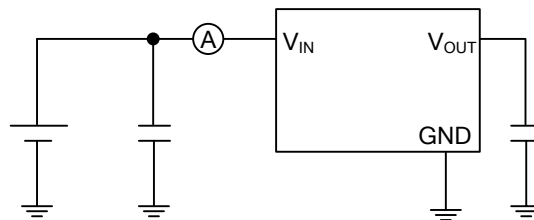
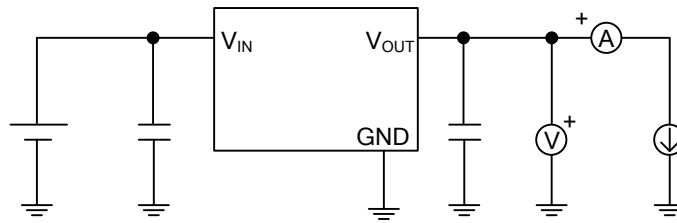

■ TYPICAL APPLICATION CIRCUIT

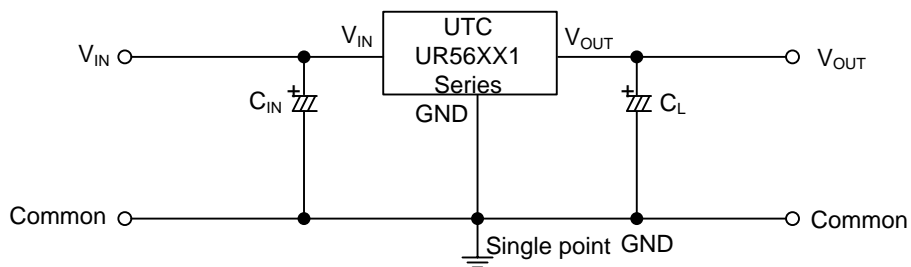

$C_{IN} > 1.0\mu F$
 $C_L > 2.2\mu F$ (tantalum capacitor)

UTC assumes no responsibility for equipment failures that result from using products at values that exceed, even momentarily, rated values (such as maximum ratings, operating condition ranges, or other parameters) listed in products specifications of any and all UTC products described or contained herein. UTC products are not designed for use in life support appliances, devices or systems where malfunction of these products can be reasonably expected to result in personal injury. Reproduction in whole or in part is prohibited without the prior written consent of the copyright owner. UTC reserves the right to make changes to information published in this document, including without limitation specifications and product descriptions, at any time and without notice. This document supersedes and replaces all information supplied prior to the publication hereof.