



**US1A  
THRU  
US1M**

**1A SURFACE MOUNT ULTRA FAST RECOVERY RECTIFIERS**

**FEATURES**

- FOR SURFACE MOUNTED APPLICATIONS
- LOW PROFILE PACKAGE
- BUILT-IN STRAIN RELIEF
- EASY PICK AND PLACE
- PLASTIC MATERIAL USED CARRIES UNDERWRITERS LABORATORY CLASSIFICATION 94 V-0
- ULTRA FAST SWITCHING
- GLASS PASSIVATED CHIP JUNCTION
- HIGH TEMPERATURE SOLDERING : 250°C/10 SECONDS AT TERMINALS

**MECHANICAL DATA**

- CASE : MOLDED PLASTIC
- TERMINALS : SOLDER PLATED
- POLARITY : INDICATED BY CATHODE BAND
- WEIGHT : 0.064 GRAMS

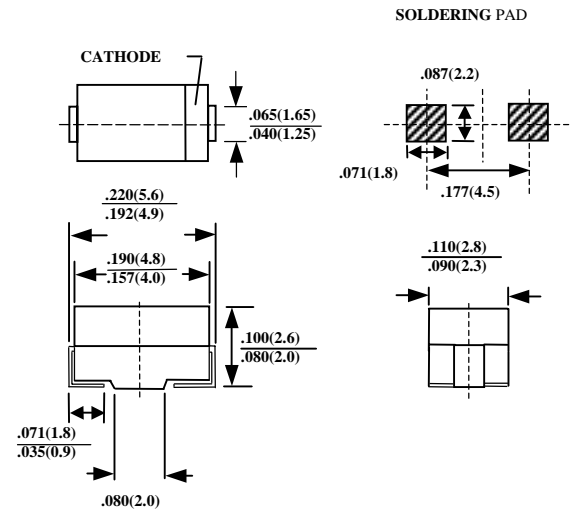

CASE : DO-214AC (SMA)  
DIMENSIONS IN INCHES AND (MILLIMETERS)

**MAXIMUM RATINGS AND ELECTRICAL CHARACTERISTICS**  
 RATINGS AT 25°C AMBIENT TEMPERATURE UNLESS OTHERWISE SPECIFIED  
 SINGLE PHASE, HALF WAVE, 60 HZ, RESISTIVE OR INDUCTIVE LOAD.  
 FOR CAPACITIVE LOAD, DERATE CURRENT BY 20%

RATINGS	SYMBOL	US1A	US1B	US1D	US1G	US1J	US1K	US1M	UNITS	
MAXIMUM RECURRENT PEAK REVERSE VOLTAGE	$V_{RRM}$	50	100	200	400	600	800	1000	V	
MAXIMUM RMS VOLTAGE	$V_{RMS}$	35	70	140	280	420	560	700	V	
MAXIMUM DC BLOCKING VOLTAGE	$V_{DC}$	50	100	200	400	600	800	1000	V	
MAXIMUM AVERAGE FORWARD RECTIFIED CURRENT AT $T_L=90^\circ\text{C}$	$I_O$	1.0								A
MAXIMUM OVERLOAD SURGE 8.3ms SINGLE HALF SINE-WAVE	$I_{FSM}$	30								A
TYPICAL JUNCTION CAPACITANCE (NOTE 1)	$C_J$	20				15				PF
TYPICAL THERMAL RESISTANCE (NOTE 2)	$\theta_{JL}$	30								$^\circ\text{C}/\text{W}$
STORAGE TEMPERATURE RANGE	$T_{STG}$	-55 TO + 150								$^\circ\text{C}$
OPERATING TEMPERATURE RANGE	$T_{OP}$	-55 TO + 125								$^\circ\text{C}$

**ELECTRICAL CHARACTERISTICS ( $A_T T_A = 25^\circ\text{C}$  UNLESS OTHERWISE NOTED)**

CHARACTERISTICS	SYMBOL	US1A	US1B	US1D	US1G	US1J	US1K	US1M	UNITS	
MAXIMUM FORWARD VOLTAGE AT 1.0A AND 25°C	$V_F$	1.0			1.3	1.7			V	
MAXIMUM REVERSE CURRENT AT 25°C	$I_R$	10								$\mu\text{A}$
MAXIMUM REVERSE RECOVERY TIME (NOTE 3)	$T_{RR}$	50				75				nS
MARKING		US1A	US1B	US1D	US1G	US1J	US1K	US1M		

- NOTE : 1. MEASURED AT 1.0 MHZ AND APPLIED REVERSE VOLTAGE OF 4.0 V  
 2. THERMAL RESISTANCE FROM JUNCTION TO TERMINAL 5.0mm<sup>2</sup> (.013 mm THICK) LAND AREAS  
 3. REVERSE RECOVERY TEST CONDITIONS:  $I_F=0.5\text{A}$ ,  $I_R=1.0\text{A}$ ,  $I_{RR}=0.25\text{A}$

# RATINGS AND CHARACTERISTIC CURVE US1A THRU US1M

**FIG. 1-TEST CIRCUIT DIAGRAM AND REVERSE RECOVERY TIME CHARACTERISTIC**

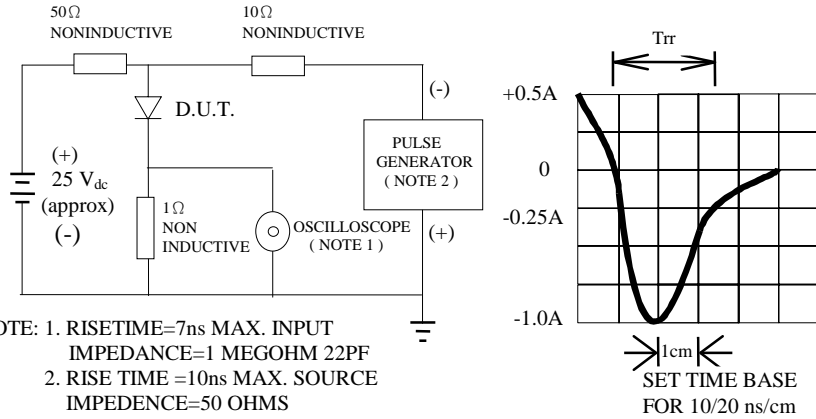

**FIG. 2-TYPICAL FORWARD CURRENT DERATING CURVE**

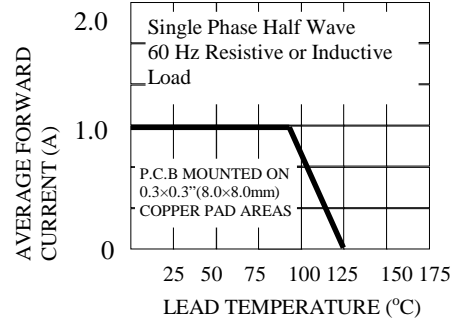

**FIG. 3-TYPICAL REVERSE CHARACTERISTICS**

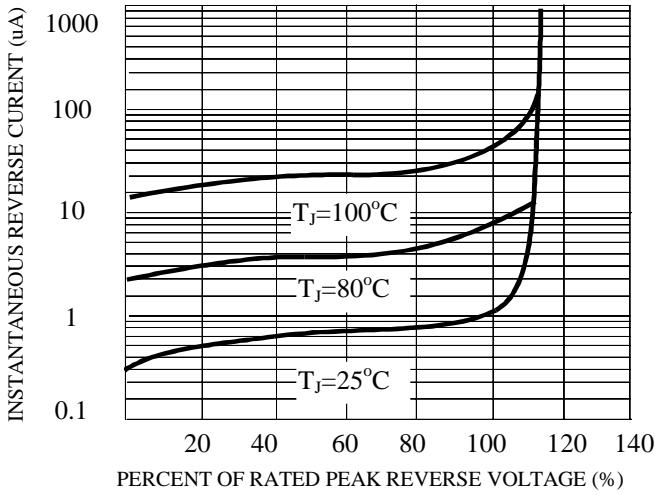

**FIG. 4-TYPICAL INSTANTANEOUS FORWARD CHARACTERISTICS**

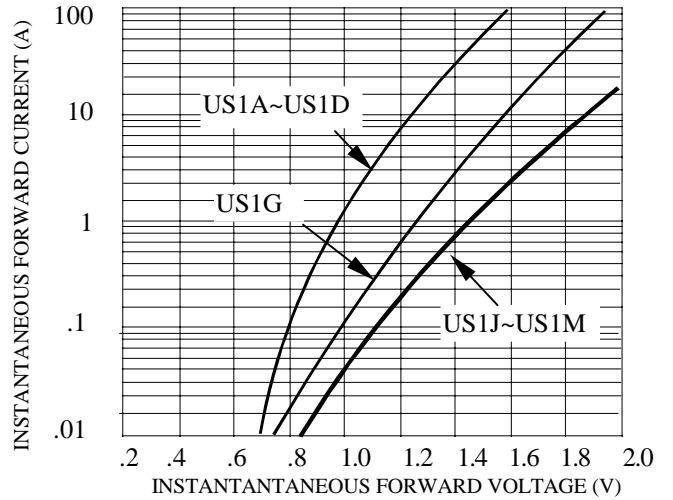

**FIG. 5-MAXIMUM NON-REPETITIVE FORWARD SURGE CURRENT**

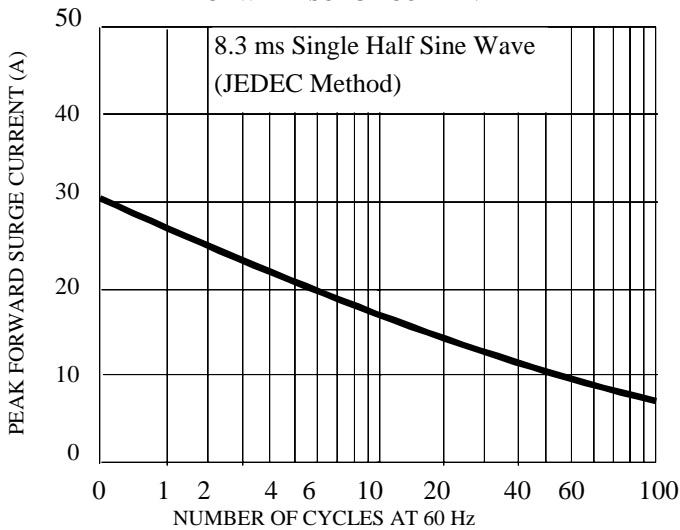

**FIG. 6-TYPICAL JUNCTION CAPACITANCE**

