



US203

CMOS IC

HIGH-SIDE POWER SWITCHES WITH FLAG

DESCRIPTION

The UTC **US203** are low voltage cost-effective high-side power switches with flag function. These devices are particularly suitable for self-powered and bus-powered USB applications. The built-in N-MOSFET's $R_{DS(ON)}$ which meets the requirements of USB voltage drop is as low as $80m\Omega$.

The UTC **US203** contains a charge pump circuitry to drive the internal MOSFET switch and also incorporate such protection circuits: soft-start circuit protect these devices from being damaged by limiting inrush current during plug-in; thermal shutdown circuit is used to prevent catastrophic switch failure from high-current loads. UVLO is used to ensure that the device remains off unless there is a valid input voltage present.

A flag output is designed to indicate fault conditions to the local USB controller. lower quiescent current as $25\mu A$ making this device ideal for portable battery-operated equipment.

The UTC **US203** are applied in USB Bus/Self powered hubs, USB peripherals, NB, PCs, PC card hot swap, battery-powered equipment, hot-plug power supplies, battery-charger circuits, ACPI power distribution.

FEATURES

- * Input Voltage Varies From 3.5V to 5.5V
- * Built-in N-MOSFET
- * Output Can Be Forced Higher Than Input (Off-State)
- * Typical Low Supply Current:
 - Switch On: $25\mu A$ (TYP)
 - Switch Off: $0.1\mu A$ (TYP)
- * Open-Drain Fault Flag Output To Indicate Fault Conditions
- * Protection Circuits:
 - Soft-start(Hot plug-in application)
 - UVLO 1.7V (TYP.)
 - Current Limiting Protection
 - Thermal Shutdown Protection
- * Reverse Current Flow Blocking (No Body Diode)

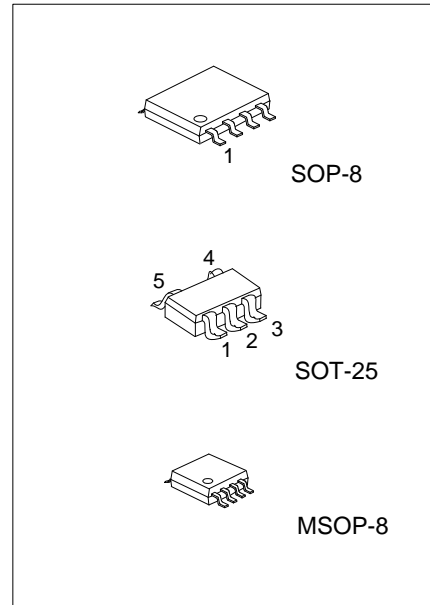

ORDERING INFORMATION

| Ordering Number | | Package | Packing |
|-----------------|----------------|---------|-----------|
| Lead Free | Halogen Free | | |
| US203XXL-AF5-R | US203XXG-AF5-R | SOT-25 | Tape Reel |
| US203XXL-S08-R | US203XXG-S08-R | SOP-8 | Tape Reel |
| US203XXL-SM1-R | US203XXG-SM1-R | MSOP-8 | Tape Reel |

| | |
|--|--|
| <p>US203XXG-AF5-R</p> <p>(1) Packing Type (2) Package Type (3) Green Package (4) Current Limit / EN Function</p> | <p>(1) R: Tape Reel (2) AF5: SOT-25, S08: SOP-8, SM1: MSOP-8 (3) G: Halogen Free and Lead Free, L: Lead Free (4) AH: 2.1A/Active High, AL: 2.1A/Active Low BH: 1.6A/Active High, BL: 1.6A/Active Low CH: 1.1A/Active High, CL: 1.1A/Active Low DH: 0.6A/Active High, DL: 0.6A/Active Low</p> |
|--|--|

MARKING

| SOT-25 | SOP-8 / MSOP-8 |
|--|--|
| <p>A: 2.1A B: 1.6A C: 1.1A D: 0.6A</p> <p>L: Lead Free G: Halogen Free H: High, L: Low</p> | <p>H: High, L: Low</p> <p>A: 2.1A B: 1.6A C: 1.1A D: 0.6A</p> <p>Date Code L: Lead Free G: Halogen Free Lot Code</p> |

■ PIN CONFIGURATION

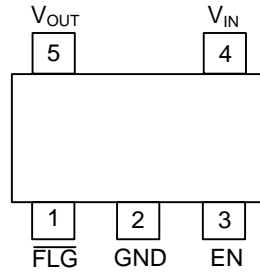

SOT-25

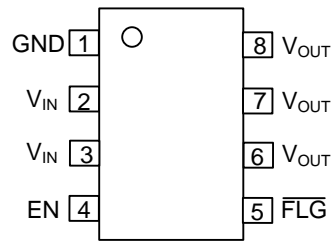

SOP-8 / MSOP-8

■ PIN DESCRIPTION

| PIN NO. | | PIN NAME | DESCRIPTION |
|-----------------|--------|------------------|--------------------------------------|
| SOP-8 MSOP-8 | SOT-25 | | |
| 6,7,8 | 5 | V _{OUT} | Output Voltage |
| 1 | 2 | GND | Ground |
| 4 | 3 | EN | Enable. Never let this pin floating. |
| 2,3 | 4 | V _{IN} | Power Input Voltage |
| 5 | 1 | FLG | Open-Drain Fault Flag Output |

■ BLOCK DIAGRAM

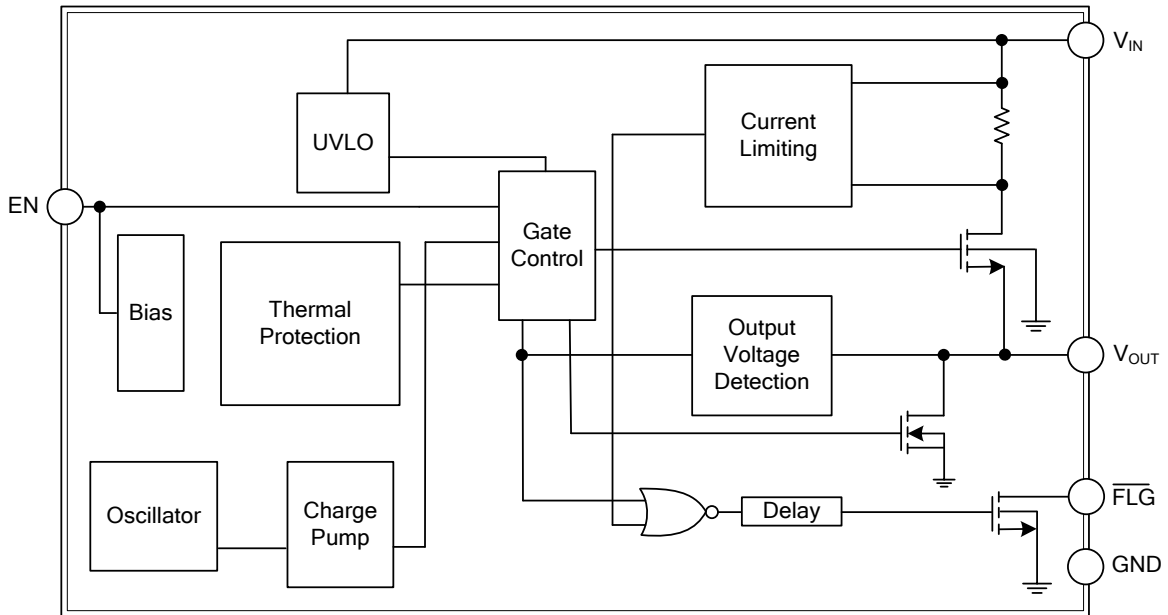

■ **ABSOLUTE MAXIMUM RATING** ($T_A = 25^\circ\text{C}$, unless otherwise specified)

| PARAMETER | SYMBOL | RATINGS | UNIT |
|--|-----------|-------------|------------------|
| Supply Voltage | V_{IN} | 6.5 | V |
| Enable Input Voltage | V_{EN} | -0.3 ~ +6.5 | V |
| Flag Voltage | V_{FLG} | 6.5 | V |
| Power Dissipation ($T_A = 25^\circ\text{C}$) | SOT-25 | 0.4 | W |
| | SOP-8 | 0.52 | W |
| | MSOP-8 | 0.42 | W |
| Junction Temperature | T_J | +125 | $^\circ\text{C}$ |
| Storage Temperature | T_{STG} | -65 ~ +150 | $^\circ\text{C}$ |

Note Absolute maximum ratings are those values beyond which the device could be permanently damaged. Absolute maximum ratings are stress ratings only and functional device operation is not implied.

■ **THERMAL DATA**

| PARAMETER | SYMBOL | RATINGS | UNIT |
|---------------------|--------|---------|--------------------|
| Junction to Ambient | SOT-25 | 250 | $^\circ\text{C/W}$ |
| | SOP-8 | 190 | $^\circ\text{C/W}$ |
| | MSOP-8 | 235 | $^\circ\text{C/W}$ |

■ **RECOMMENDED OPERATING CONDITIONS**

| PARAMETER | SYMBOL | RATINGS | UNIT |
|-------------------------------|-------------|------------|------------------|
| Supply Input Voltage | V_{IN} | 3.5 ~ 5.5 | V |
| Enable Input Voltage | $V_{I(EN)}$ | 0 ~ 5.5 | V |
| Junction Temperature | T_J | -40 ~ +125 | $^\circ\text{C}$ |
| Ambient Operating Temperature | T_{OPR} | -40 ~ +85 | $^\circ\text{C}$ |

■ **ELECTRICAL CHARACTERISTICS** ($V_{IN}=5V$, $C_{IN}=C_{OUT}=1\mu F$, $T_A=25^\circ C$, unless otherwise specified)

| PARAMETER | | SYMBOL | TEST CONDITIONS | MIN | TYP | MAX | UNIT | |
|--|------------|---------------------------|--|-----|------|-----|------------|---|
| Switch On Resistance (US203A, US203B) | SOT-25 | $R_{DS(ON)}$ | $I_{OUT}=1A, V_{IN}=5V$ | | 80 | 100 | m Ω | |
| | SOP-8 | | | | 90 | 110 | | |
| | MSOP-8 | | | | | | | |
| Switch On Resistance (US203C, US203D) | SOT-25 | $R_{DS(ON)}$ | $I_{OUT}=0.5A, V_{IN}=5V$ | | 80 | 100 | m Ω | |
| | SOP-8 | | | | 90 | 110 | | |
| | MSOP-8 | | | | | | | |
| Supply Current | | I_{SW_ON} | switch on, R_{LOAD} Open | | 25 | 45 | μA | |
| | | I_{SW_OFF} | switch off, R_{LOAD} Open | | 0.1 | 1 | | |
| EN Threshold Voltage | Logic-Low | V_{IL} | $V_{IN}=3.5V \sim 5.5V$ | | | 0.8 | V | |
| | Logic-High | V_{IH} | $V_{IN}=3.5V \sim 5.5V$ | 2.0 | | | V | |
| EN Input Current | | I_{EN} | $V_{EN}/\overline{EN}=0V \sim 5.5V$ | | 0.01 | | μA | |
| Output Leakage Current | | $I_{O(LEAK)}$ | $V_{EN}=0V, R_{LOAD}=0\Omega$ | | 0.5 | 10 | μA | |
| Output Turn-On Rise Time | | $T_{ON(RISE)}$ | 10% to 90% of V_{OUT} rising | | 400 | | μs | |
| Current Limit | US203Ax | I_{LIMIT} | Current Ramp (< 0.1A/ms) on V_{OUT} | | 2.1 | 2.5 | 3.2 | A |
| | US203Bx | | | | 1.6 | 2.0 | 2.5 | A |
| | US203Cx | | | | 1.1 | 1.5 | 1.8 | A |
| | US203Dx | | | | 0.6 | 0.8 | 1.1 | A |
| Short Circuit Fold-Back Current | US203Ax | $I_{SC(FB)}$ | $V_{OUT}=0V$, measured prior to thermal shutdown | | 1 | | | A |
| | US203Bx | | | | 1 | | | A |
| | US203Cx | | | | 1 | | | A |
| | US203Dx | | | | 1 | | | A |
| FLAG Output Resistance | | $R_{\overline{FLG}}$ | $I_{SINK}=1mA$ | | 20 | 400 | Ω | |
| FLAG Off Current | | $I_{\overline{FLG_OFF}}$ | $V_{\overline{FLG}}=5V$ | | 0.01 | 1 | μA | |
| FLAG Delay Time | | t_D | From fault condition to \overline{FLG} assertion | 5 | 12 | 20 | ms | |
| Shutdown Pull-Low Resistance | | R_{DS} | $V_{EN}=0V, \overline{V_{EN}}$ | | 75 | 150 | Ω | |
| Under-Voltage Lockout | | V_{UVLO} | V_{IN} increasing | 1.3 | 1.7 | | V | |
| Under-Voltage Hysteresis | | ΔV_{UVLO} | V_{IN} decreasing | | 0.1 | | V | |
| Thermal Shutdown Protection | | T_{SD} | | | 130 | | $^\circ C$ | |
| Thermal Shutdown Hysteresis | | ΔT_{SD} | | | 20 | | $^\circ C$ | |

Note: The device is not guaranteed to function outside its operating conditions.

■ APPLICATION INFORMATION

Input and Output

V_{IN} (input) is the power source connection to the internal circuitry and the drain of the MOSFET. V_{OUT} (output) is the source of the MOSFET. In a typical application, current flows through the switch from V_{IN} to V_{OUT} toward the load. Because the MOSFET is bidirectional when on, if V_{OUT} is greater than V_{IN} , current will flow from V_{OUT} to V_{IN} .

There is no parasitic body diode of N-MOSFET between the drain and source compared to a normal MOSFET. The **US203** can protect damage from reverse current flow if V_{OUT} being externally forced to a higher voltage than V_{IN} when the output disabled ($V_{EN} > 2V$).

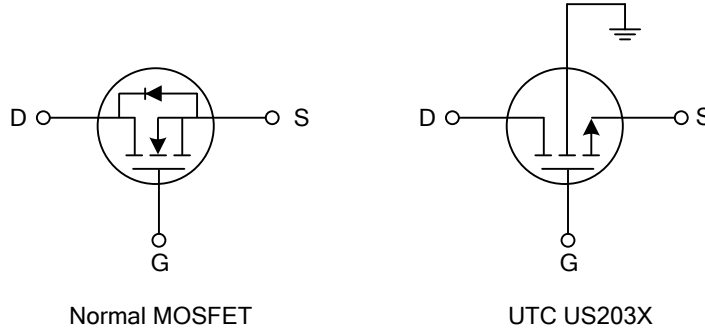

Enable Input

The switch will be disabled when the EN pin is in a logic low/high condition. During this condition, the internal circuitry and MOSFET are turned off, reducing the supply current to 0.1 μ A typical. Floating the EN may cause unpredictable operation. EN should not be allowed to go negative with respect to GND. The EN pin may be directly tied to V_{IN} (GND) to keep the part on.

Soft Start for Hot Plug-In Applications

When hot-plug events occur, the soft start is used to eliminate the upstream voltage droop due to the inrush current. The soft-start protects power supplies from damage caused by highly capacitive loads.

Fault Flag

The fault flag is an open-drained output of an N-channel MOSFET. The flag drops low to indicate fault conditions: current limit, thermal shutdown or $V_{OUT} < V_{IN} - 1V$. In order to reduce energy drain, a large pull-up resistor is required. 100k Ω pull-up resistor is recommended for most applications.

In the case of over current condition, the fault flag is active only if the flag response delay time (t_D) has elapsed. This ensures that FLG is asserted only upon valid over-current conditions and that erroneous error reporting is eliminated. For example, false over-current conditions may occur during hot-plug events when extremely large capacitive loads are connected and causes a high transient inrush current that exceeds the current limit threshold. The FLG response delay time t_D is typically 10ms.

Under-Voltage Lockout

UVLO (Under-voltage Lockout) turns off the MOSFET switch once the input voltage falls below 1.3V, and the \overline{FLG} is in active. If the input voltage exceeds approximately 1.7V, the switch will be turned on. Under-voltage detection functions only when the switch is enabled.

Current Limiting and Short-Circuit Protection

The current limit circuit protects the MOSFET switch and the hub downstream port from damage. This circuit can deliver load current up to the current limit threshold of typically 2.5A through the switch of US203AH/AL, 2A for US203BH/BL, 1.5A for US203CH/CL and 0.8A for US203DH/DL. When an enabled switch applies a heavy load or short circuit, a large-desired transient current occurs which can cause the current limit circuit response. If this current becomes higher than the current limit threshold, the devices enter constant current mode until thermal shutdown occurs or the fault is removed.

■ APPLICATION INFORMATION(Cont.)

Thermal Shutdown

The thermal shutdown circuit is used to prevent damage occurs when the die temperature becomes higher than approximately 130°C. After 20°C of hysteresis, the switch will automatically restart if it enabled. When these devices are disabled or the fault is removed, the output and $\overline{\text{FLG}}$ signal will continue to cycle on and off.

Power Dissipation

The UTC **US203**'s junction temperature varies depending the several factors such as the load, PCB layout, ambient temperature and package type. The output pin of UTC **US203** can deliver the current of up to 2.5A(US203AH/AL), 2A(US203BH/BL), 1.5A(US203CH/CL) and 0.8A(US203DH/DL) over the full operating junction temperature range. However, at higher ambient temperature the maximum output current must be derated to ensure the junction temperature does not exceed 100°C. With all possible conditions, the junction temperature must be within the range specified under operating conditions. Power dissipation is determined by the output current and the $R_{DS(ON)}$ of switch, the relationship between them is as seen is the following:

$$P_D = R_{DS(ON)} \times I_{OUT}^2$$

Although the devices are rated for 2.5A, 2A, 1.5A and 0.8A of output current, but the application may limit the amount of output current based on the total power dissipation and the ambient temperature. The final operating junction temperature for any set of conditions is calculated as follows:

$$P_{D(MAX)} = (T_{J(MAX)} - T_A) / \theta_{JA}$$

Universal Serial Bus (USB) & Power Distribution

The USB's goal is to be enabled device from different vendors to interoperate in an open architecture. The USB is characterized incorporating ease of use for the end user, a wide range of workloads and applications, robustness, synergy with the PC industry, and low-cost implementation. In addition, the benefits of the USB contain self-identifying peripherals, dynamically attachable and reconfigurable peripherals, multiple connections (support for concurrent operation of many devices), support physical devices up to 127, and compatibility with PC Plug-and-Play architecture.

Each USB system has one USB host, and the USB connects USB devices with a USB host. USB devices can be classified either as hubs, which provide additional attachment points to the USB, or as functions, which provide capabilities to the system (for example, a digital joystick). Then the hub devices are classified as either bus-power hubs or self-powered Hubs.

Self-powered hub power for the internal functions and downstream ports does not come from the USB, although the USB interface may draw up to 100mA from its upstream connect, to allow the interface to function when the remainder of the hub is powered down. The hub must be able to supply up to 500mA on all of its external downstream ports. Over-current protection devices such as fuses and PTC resistors (also called poly fuse or polyswitch) have slow trip times, high on-resistance, and lack the necessary circuitry for USB-required fault reporting. A bus-powered hub draws all of the power to any internal functions and downstream ports from the USB connector power pins. The hub may draw current as high as 500mA from the upstream device. External ports in a bus-powered hub can supply up to 100mA per port, with a maximum of four external ports.

In order to protect the hubs to operating on the faults conditions, the faster trip time of the UTC **US203** power distribution can make it. For meeting voltage regulation and fault notification requirements, low on-resistance and internal fault-reporting circuitry are required.

Furthermore, because the devices are power switches, they provide the designer of self-powered hubs flexibility to turn off power to output ports. The devices have controlled rise and fall times to provide the needed inrush current limiting required for the bus-powered hub power switch compared to a normal MOSFET.

Supply Filter/Bypass Capacitor

To prevent input voltage droop occurs during hot-plug condition, a 1uF low-ESR ceramic capacitor located between V_{IN} and GND is strongly desired. However, higher capacitor values will further reduce the voltage droop on the input. Furthermore, without the bypass capacitor, an output short may cause sufficient ringing on the input (from source lead inductance) to destroy the internal control circuitry. The input transient's value must be not higher than the absolute maximum supply voltage (6.5V) even for a short duration.

■ APPLICATION INFORMATION(Cont.)

Output Filter Capacitor

To meet the requirement of the maximum droop (330mV) in the hub V_{BUS} , a 150 μ F low-ESR electrolytic or tantalum located from V_{OUT} and GND is strongly desired. Standard bypass methods should be used to minimize inductance and resistance between the bypass capacitor and the downstream connector to reduce EMI and decouple voltage droop caused when downstream cables are hot-insertion transients. For EMI and ESD protection consideration, ferrite beads in **US203** with V_{BUS} , the ground line and the 0.1 μ F bypass capacitors at the power connector pins are needed. The bypass capacitor itself should have a low dissipation factor to allow decoupling at higher frequencies.

Voltage Drop

A minimum port-output voltage in two locations on the bus is shown in the USB specification, in which, 4.75V out of a self-powered hub port and 4.40V out of a bus-powered hub port. As with the self-powered hub, all resistive voltage drops for the bus-powered hub must be accounted for to guarantee voltage regulation. $V_{OUT(MIN)}$ for multiple ports (N_{PORTS}) ganged together through one switch (if using one switch per port, N_{PORTS} is equal to 1) can be established by the following equation:

$$V_{OUT(MIN)} = 4.75V - [I_I \times (4 \times R_{CONN} + 2 \times R_{CABLE})] - (0.1A \times N_{PORTS} \times R_{SWITCH}) - V_{PCB}$$

Where,

R_{CONN} = Resistance of connector contacts (two contacts per connector)

R_{CABLE} = Resistance of upstream cable wires (one 5V and one GND)

R_{SWITCH} = Resistance of power switch (80m Ω typical for UTC **US203**)

V_{PCB} = PCB voltage drop

The USB specification defines the maximum resistance per contact (R_{CONN}) of the USB connector to be 30m Ω and the drop across the PCB and switch to be 100mV. This basically leaves two variables in the equation: the resistance of the switch and the resistance of the cable. If the hub consumes the maximum current (I_I) of 500mA, the maximum resistance of the cable is 90m Ω . The following equation determines the resistance of the switch:

$$R_{SWITCH} = \{ 4.75V - 4.4V - [0.5A \times (4 \times 30m\Omega + 2 \times 90m\Omega)] - V_{PCB} \} \div (0.1A \times N_{PORTS})$$

$$= (200mV - V_{PCB}) \div (0.1A \times N_{PORTS})$$

If the voltage drop across the PCB is limited to 100mV, the maximum resistance for the switch is 250m Ω for four ports ganged together. The UTC **US203**, with its maximum 100m Ω on-resistance over temperature, easily meets this requirement.

PCB Layout Guide

Careful PCB layout should be taken into consideration for meeting the requirements of the voltage drop, droop, and EMI.

The following guidelines must be paid attention.

- ⊙ Output capacitor and ferrite beads should be placed as close to the USB connectors as possible to lower impedance (mainly inductance) between the port and the capacitor and improve transient load performance.
- ⊙ The UTC **US203** should be placed as close as possible to the output port to limit switching noise.
- ⊙ Ceramic bypass capacitors should be placed as close as possible to the VIN pins of the UTC **US203**
- ⊙ Keep all VBUS traces as short as possible and use at least 50-mil, 2 ounce copper for all VBUS traces.
- ⊙ Avoid VIAS as much as possible. If VIAS are necessary, make them as large as feasible.
- ⊙ Place a ground plane under all circuitry to lower both resistance and inductance and improve DC and transient performance (Use a separate ground and power plans if possible).
- ⊙ Place cuts in the ground plane between ports to help reduce the coupling of transients between ports.

■ TYPICAL APPLICATION CIRCUIT

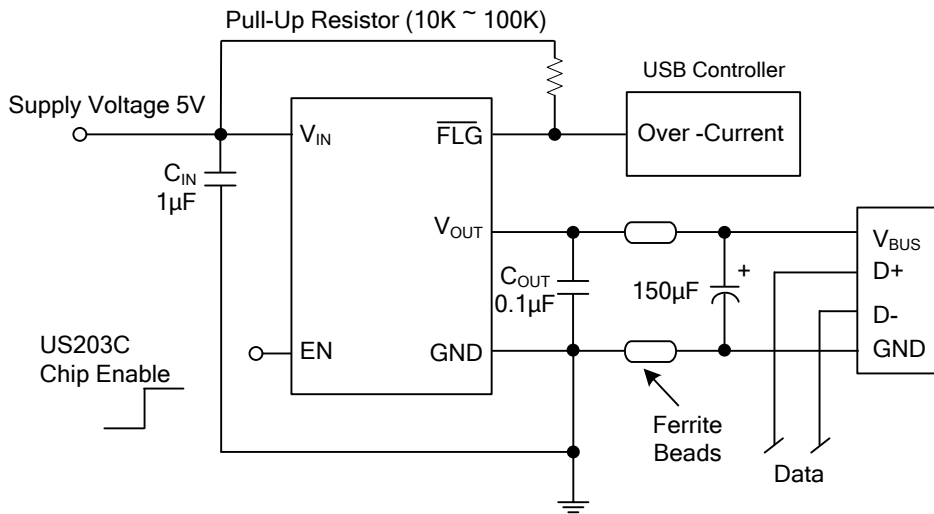

Note: A low-ESR 150µF aluminum electrolytic or tantalum between V_{OUT} and GND is strongly recommended to meet the 330mV maximum droop requirement in the hub V_{BUS}. (see Application Information Section for further details)

UTC assumes no responsibility for equipment failures that result from using products at values that exceed, even momentarily, rated values (such as maximum ratings, operating condition ranges, or other parameters) listed in products specifications of any and all UTC products described or contained herein. UTC products are not designed for use in life support appliances, devices or systems where malfunction of these products can be reasonably expected to result in personal injury. Reproduction in whole or in part is prohibited without the prior written consent of the copyright owner. UTC reserves the right to make changes to information published in this document, including without limitation specifications and product descriptions, at any time and without notice. This document supersedes and replaces all information supplied prior to the publication hereof.