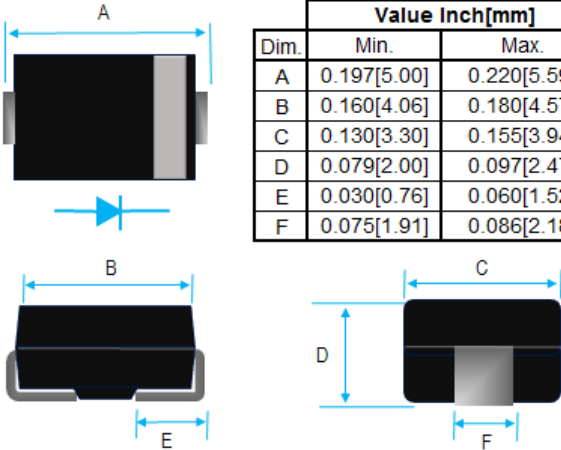

2A ULTRA FAST RECOVERY SURFACE MOUNT RECTIFIER

	Value Inch[mm]	
	Dim.	Min.
A	0.197[5.00]	0.220[5.59]
B	0.160[4.06]	0.180[4.57]
C	0.130[3.30]	0.155[3.94]
D	0.079[2.00]	0.097[2.47]
E	0.030[0.76]	0.060[1.52]
F	0.075[1.91]	0.086[2.18]

PRODUCT FEATURES

1. FLAMMABILITY CLASSIFICATION: 94V-0
2. GLASS PASSIVATED CHIP JUNCTION
3. BUILT-IN STRAIN RELIEF
4. LOW PROFILE
5. ULTRA FAST SWITCHING
6. CASE: MOLDED PLASTIC, DO-214AC (SMA-F)
7. POLARITY: INDICATED BY CATHODE BAND
8. WEIGHT: 0.093 GRAMS
9. LEADS: SOLDERABILITY PER MIL-STD-750 METHOD 2026
10. RoHS

MAXIMUM RATINGS AND ELECTRICAL CHARACTERISTICS RATINGS AT 25°C AMBIENT TEMPERATURE UNLESS OTHERWISE SPECIFIED STORAGE AND OPERATING TEMPERATURE RANGE -55°C TO +150°C. SINGLE PHASE, HALF WAVE, 60 HZ, RESISTIVE OR INDUCTIVE LOAD. FOR CAPACITIVE LOAD, DERATE CURRENT BY 20%.

RATINGS	SYMBOL	VALUE	UNITS
MAXIMUM AVERAGE FORWARD RECTIFIED CURRENT @ 90°C	I_o	2	A
PEAK FWD SURGE CURRENT, 8.3ms HALF SINE-WAVE SUPERIMPOSED ON RATED LOAD	I_{FSM}	50	A
TYPICAL JUNCTION CAPACITANCE(NOTE 1)	C_j	28	pF
TYPICAL THERMAL RESISTANCE (NOTE 2)	$R_{\theta ja}$	20	°C/W
MAXIMUM REVERSE CURRENT @ 25°C	I_R	10	uA
MAXIMUM REVERSE CURRENT @ 100 °C	I_R	200	uA

1. C_j MEASURED @ 1 MHZ AND APPLIED REVERSE VOLTAGE OF 4.0 VOLTS

2. THERMAL RESISTANCE FROM JUNCTION TO AMBIENT AND JUNCTION TO LEAD PCB MOUNTED ON 0.3x0.3"(8.0x8.0mm) COPPER PAD AREAS

3. REVERSE RECOVERY TEST CONDITIONS: $I_F=0.5A$, $I_R=1.0A$, $I_{RR}=0.25A$

4. MAXIMUM FORWARD VOLTAGE @ I_o DC

PART NUMBER	MAX RECURRENT PEAK REV VOLTAGE V_{RRM} (V)	MAX RMS VOLTAGE V_{RMS} (V)	MAX DC BLOCKING VOLTAGE V_{DC} (V)	MAX FWD VOLTAGE V_F (V)	MAX REVERSE RECOVERY TIME T_{RR} (nS)
US2A	50	35	50	1.0	50
US2B	100	70	100	1.0	50
US2D	200	140	200	1.0	50
US2G	400	280	400	1.3	50
US2J	600	420	600	1.7	75
US2K	800	560	800	1.7	75
US2M	1000	700	1000	1.7	75

RATING AND CHARACTERISTIC CURVES

FIG. 1-TEST CIRCUIT DIAGRAM AND REVERSE RECOVERY TIME CHARACTERISTIC

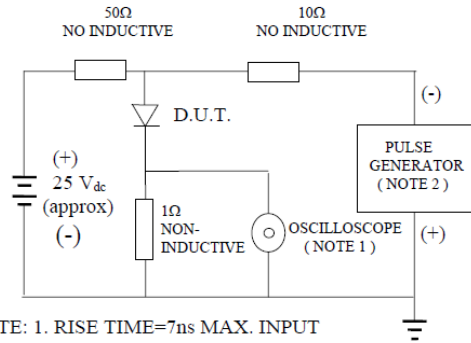

NOTE: 1. RISE TIME=7ns MAX. INPUT IMPEDANCE=1 MOhms 22PF
 2. RISE TIME =10ns MAX. SOURCE IMPEDANCE=50 OHMS

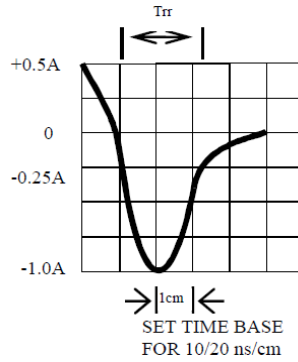

FIG. 2-TYPICAL FORWARD CURRENT DERATING CURVE

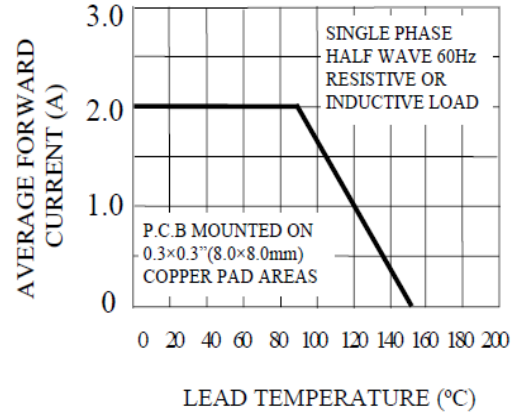

FIG. 3-TYPICAL REVERSE CHARACTERISTICS

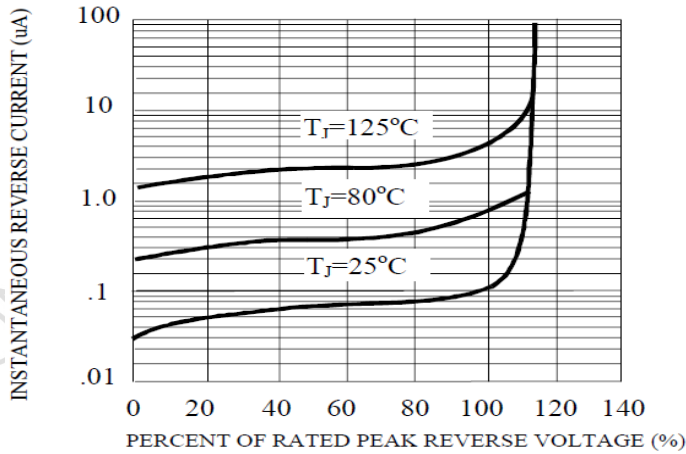

FIG. 4-TYPICAL INSTANTANEOUS FORWARD CHARACTERISTICS

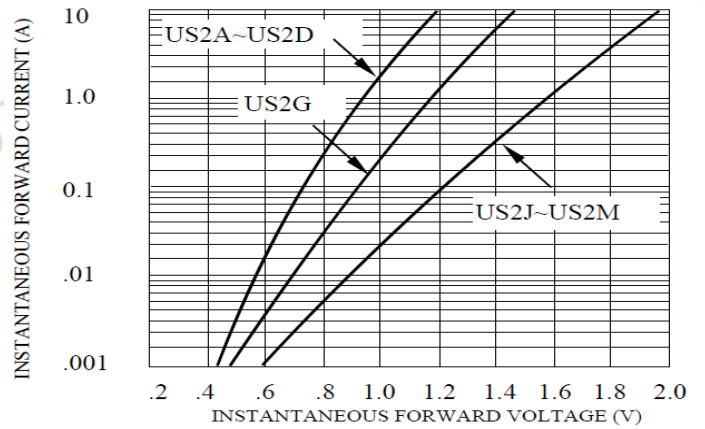

FIG. 5-MAXIMUM NON-REPETITIVE FORWARD SURGE CURRENT

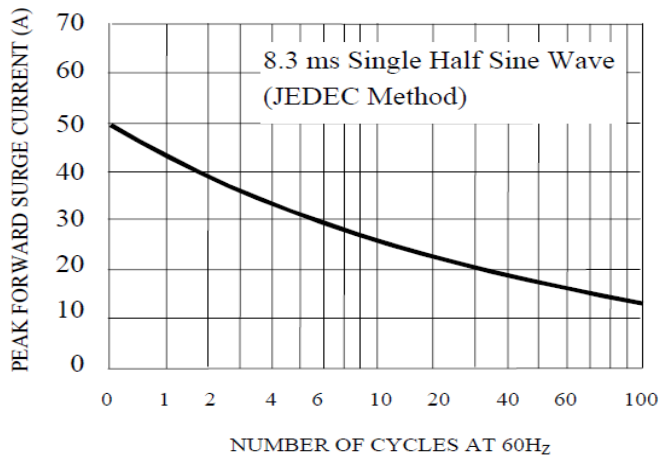

FIG. 6-TYPICAL JUNCTION CAPACITANCE

