

5 BIT PROGRAMMABLE SYNCHRONOUS BUCK PLUS TRIPPLE LDO CONTROLLER PRELIMINARY DATASHEET

FEATURES

- Provides Single Chip Solution for Vcore, GTL+ ,AGP Bus, and 1.8V
- Automatic Voltage Selection for AGP slot Vddq supply
- Linear regulator controller on board for 1.8V
- Designed to meet Intel Latest VRM specification for next generation microprocessors
- On board DAC programs the output voltage from 1.3V to 3.5V
- Linear regulator controller on board for 1.5V GTL+ supply
- Loss less Short Circuit Protection for all outputs
- Synchronous operation allows maximum efficiency
- Patented architecture allows fixed frequency operation as well as 100% duty cycle during dynamic load
- Minimum part count
- Soft Start
- High current totem pole driver for direct driving of the external Power MOSFET
- Power Good function Monitors all Outputs
- OVP Circuitry Protects the Switcher Output and generates a Fault output

APPLICATIONS

- Total Power Solution for Next Generation Intel Processor application

DESCRIPTION

The US3021B controller IC is specifically designed to meet Intel specification for next generation microprocessor applications requiring multiple on board regulators . The US3021B provides a single chip controller IC for the Vcore , 3LDO controllers, one with the automatic select pin that connects to the TYPE DETECT pin of the AGP slot for the AGP Vddq supply, one for GTL+ and the other for the 1.8V chip set regulator as required for the next generation PC applications. The US3021B typically uses Bipolar transistors for Vout3(1.5V) and Vout4(1.8V) however if Vaux pin is connected to 12V, then MOSFETs can also be used as external pass elements. No external resistor divider is necessary for any of the regulators. The switching regulator feature a patented topology that in combination with a few external components as shown in the typical application circuit ,will provide well in excess of 20A of output current for an on-board DC/DC converter while automatically providing the right output voltage via the 5 bit internal DAC .The US3021B also features, loss less current sensing for both switcher by using the Rds-on of the high side Power MOSFET as the sensing resistor, an output under voltage shutdown that detects short circuit condition for the linear outputs and latches the system off, and a Power Good window comparator that switches its open collector output low when any one of the outputs is outside of a pre programmed window.

TYPICAL APPLICATION

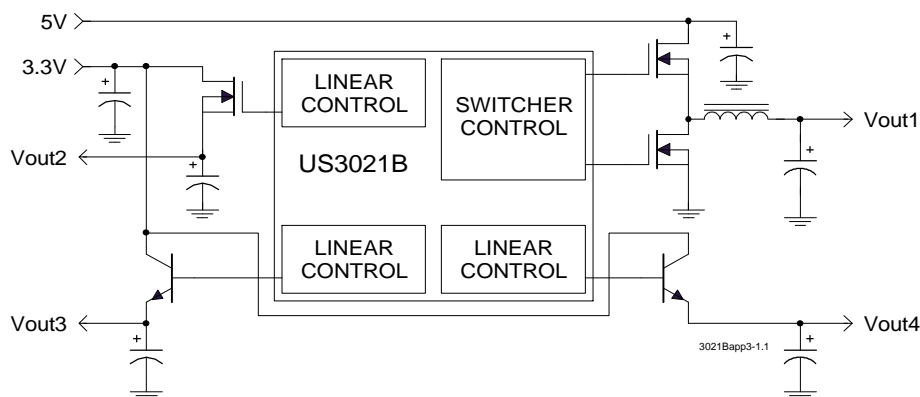

PACKAGE ORDER INFORMATION

Ta (°C)	Device	Package
0 TO 70	US3021BCW	28 pin Plastic SOIC WB

US3021B

ABSOLUTE MAXIMUM RATINGS

V5 supply Voltage 7V
 V12 Supply Voltage 20V
 Storage Temperature Range -65 TO 150°C
 Operating Junction Temperature Range 0 TO 125°C

PACKAGE INFORMATION

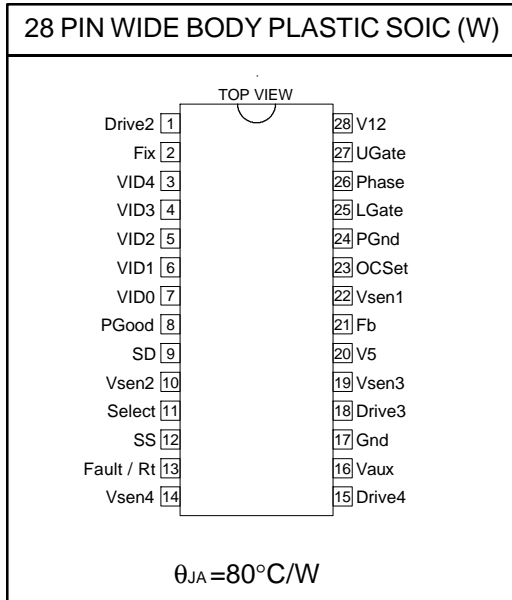

ELECTRICAL SPECIFICATIONS

Unless otherwise specified, these specifications apply over, V12 = 12V, V5 = 5V and Ta = 0 to 70°C. Typical values refer to Ta = 25°C. Low duty cycle pulse testing are used which keeps junction and case temperatures equal to the ambient temperature.

PARAMETER	SYM	TEST CONDITION	MIN	TYP	MAX	UNITS
Supply UVLO Section						
UVLO Threshold-12V		Supply ramping up		10		V
UVLO Hysterises-12V				0.6		V
UVLO Threshold-5V		Supply ramping up		4.4		V
UVLO Hysterises-5V				0.3		V
Supply Current						
Operating Supply Current		V12 V5		6 30		mA

Switching Controllers; Vcore (Vsen 1) and AGP (Vsen 2)

VID Section (Vcore only)

DAC output voltage (note 1)			0.99Vs	Vs	1.01Vs	V
DAC Output Line Regulation				0.1		%
DAC Output Temp Variation				0.5		%
VID Input LO					0.8	V
VID Input HI			2			V
VID input internal pull-up resistor to V5				27		kΩ
Vsen2 Voltage		Select < 0.8V		1.5		V
		Select > 2V		3.3		V

Error Comparator Section						
Input bias current					2	uA
Input Offset Voltage			-2		+2	mV
Delay to Output		Vdiff=10mV			100	nS
Current Limit Section						
C.S Threshold Set Current				200		uA
C.S Comp Offset Voltage			-5		+5	mV
Hiccup Duty Cycle		Css=0.1 uF		10		%
Output Drivers Section						
Rise Time		CL=3000pF		70		nS
Fall Time		CL=3000pF		70		nS
Dead band Time Between High side and Synch Drive (Vcore Switcher Only)		CL=3000pF		200		nS
Oscillator Section (internal)						
Osc Frequency		Rt=Open		217		Khz
1.8V Regulator (Vsen 4)						
Vsense Voltage	Vo4	Ta=25, Drive4 = Vsen4		1.800		V
Vsense Voltage				1.800		V
Input bias current					2	uA
Output Drive Current		Vaux-Vdrive>0.6V	50			mA
1.5V Regulator (Vsen 3)						
Vsense Voltage	Vo3	Ta=25, Drive3 = Vsen3		1.500		V
Vsense Voltage				1.500		V
Input bias current					2	uA
Output Drive Current		Vaux-Vdrive>0.6V	50			mA
Power Good Section						
Vsen1 UV lower trip point		Vsen1 ramping down		0.90Vs		V
Vsen1 UV upper trip point		Vsen1 ramping up		0.92Vs		V
Vsen1 UV Hysterises				.02Vs		V
Vsen1 HV upper trip point		Vsen1 ramping up		1.10Vs		V
Vsen1 HV lower trip point		Vsen1 ramping down		1.08Vs		V
Vsen1 HV Hysterises				.02Vs		V
Vsen2 trip point		Select<0.8V		1.100		V
		Select>2V		2.560		V
Vsen4 trip point		Fix=GND		0.920		V
		Fix=Open		1.320		V
Vsen3 trip point		Fix=GND		0.920		V
		Fix=Open		1.140		V
Power Good Output LO		RL=3mA		0.4		V
Power Good Output HI		RL=5K pull up to 5V		4.8		V
Fault (Overvoltage) Section						
Core O.V. upper trip point		Vsen1 ramping up		1.17Vs		V
Core O.V. lower trip point		Vsen1 ramping down		1.15Vs		V
FAULT Output HI		Io=3mA		10		V
Soft Start Section						
Soft Start Current		OCset=0V , Phase=5V		20		uA

US3021B

Note 1: Vs refers to the set point voltage given in Table 1.

D4	D3	D2	D1	D0	Vs	D4	D3	D2	D1	D0	Vs
0	1	1	1	1	1.30	1	1	1	1	1	2.0
0	1	1	1	0	1.35	1	1	1	1	0	2.1
0	1	1	0	1	1.40	1	1	1	0	1	2.2
0	1	1	0	0	1.45	1	1	1	0	0	2.3
0	1	0	1	1	1.50	1	1	0	1	1	2.4
0	1	0	1	0	1.55	1	1	0	1	0	2.5
0	1	0	0	1	1.60	1	1	0	0	1	2.6
0	1	0	0	0	1.65	1	1	0	0	0	2.7
0	0	1	1	1	1.70	1	0	1	1	1	2.8
0	0	1	1	0	1.75	1	0	1	1	0	2.9
0	0	1	0	1	1.80	1	0	1	0	1	3.0
0	0	1	0	0	1.85	1	0	1	0	0	3.1
0	0	0	1	1	1.90	1	0	0	1	1	3.2
0	0	0	1	0	1.95	1	0	0	1	0	3.3
0	0	0	0	1	2.00	1	0	0	0	1	3.4
0	0	0	0	0	2.05	1	0	0	0	0	3.5

Table 1 - Set point voltage vs. VID codes

PIN DESCRIPTIONS

PIN#	PIN SYMBOL	Pin Description
7	VID0	LSB input to the DAC that programs the output voltage. This pin is TTL compatible that realizes a logic "1" as either HI or Open. When left open, his pin is pulled up internally by a 27kΩ resistor to 5V supply.
6	VID1	Input to the DAC that programs the output voltage. This pin is TTL compatible that realizes a logic "1" as either HI or Open. When left open, his pin is pulled up internally by a 27kΩ resistor to 5V supply.
5	VID2	Input to the DAC that programs the output voltage. This pin is TTL compatible that realizes a logic "1" as either HI or Open. When left open, his pin is pulled up internally by a 27kΩ resistor to 5V supply.
4	VID3	MSB input to the DAC that programs the output voltage. This pin is TTL compatible that realizes a logic "1" as either HI or Open. When left open, his pin is pulled up internally by a 27kΩ resistor to 5V supply.
3	VID4	This pin selects a range of output voltages for the DAC. When in the LOW state the range is 1.3V to 2.05V and when it switches to HI state the range is 2.0V to 3.5V. This pin is TTL compatible that realizes a logic "1" as either HI or Open. When left open, his pin is pulled up internally by a 27kΩ resistor to 5V supply.
8	PGOOD	This pin is an open collector output that switches LO when any of the outputs are outside of the specified under voltage trip point. It also switches low when Vsen1 pin is more than 10% above the DAC voltage setting.
21	FB	This pin provides the feedback for the synchronous switching regulator. Typically this pin can be connected directly to the output of the switching regulator. However, a resistor divider is recommended to be connected from this pin to vout1 and GND to adjust the output voltage for any drop in the output voltage that is caused by the trace resistance. The value of the resistor connected from Vout1 to FB1 must be less than 1000Ω.
1	Drive2	This pin controls the gate of an external MOSFET for the AGP linear regulator.
9	SD	This pin provides shutdown for all the regulatos. A TTL compatible, logic level high applied to this pin disables all the outputs and discharges the soft start capacitor. The SD signal turns off the synchronous allowing body diode to conduct and discharge the output cap.

PIN#	PIN SYMBOL	Pin Description
22	Vsen1	This pin is internally connected to the undervoltage and overvoltage comparators sensing the Vcore status. It must be connected directly to the Vcore supply.
10	Vsen2	This pin provides the feedback for the AGP linear regulator. The Select pin when connected to the "Type Detect" pin of the AGP slot automatically selects the right voltage for the AGP Vddq.
15	Drive4	This pin controls the gate of an external MOSFET for the 1.8V chip set linear regulator.
23	OCSET	This pin is connected to the Drain of the power MOSFET of the Core supply and it provides the positive sensing for the internal current sensing circuitry. An external resistor programs the C.S threshold depending on the Rds of the power MOSFET. An external capacitor is placed in parallel with the programming resistor to provide high frequency noise filtering.
26	PHASE	This pin is connected to the Source of the power MOSFET for the Core supply and it provides the negative sensing for the internal current sensing circuitry.
12	SS	This pin provides the soft start for all the regulators. An internal current source charges an external capacitor that is connected from this pin to GND which ramps up the outputs of the regulators, preventing the outputs from overshooting as well as limiting the input current. The second function of the Soft Start cap is to provide long off time (HICCUP) for the synchronous MOSFET during current limiting.
13	FAULT/Rt	This pin has dual function. It acts as an output of the OVP circuitry or it can be used to program the frequency using an external resistor. When used as a fault detector, if any of the switcher outputs exceed the OVP trip point, the FAULT pin switches to 12V and the soft start cap is discharged. If the FAULT pin is to be connected to any external circuitry, it needs to be buffered.
18	Drive3	This pin controls the gate of an external transistor for the 1.5V GTL+ linear regulator.
19	Vsen3	This pin provides the feedback for the linear regulator that its output drive is Drive3.
16	Vaux	This pin is normally connected to 3.3V or 5V input. When connected to the 12V supply, it provides gate drive voltage for the # 3 and #4 (Drive 3 and 4) linear regulator's pass transistors in case MOSFET transistors are being used instead of Bipolars.
14	Vsen4	This pin provides the feedback for the linear regulator that its output drive is Drive4.
17	GND	This pin serves as the ground pin and must be connected directly to the ground plane.
24	PGND	This pin serves as the Power ground pin and must be connected directly to the GND plane close to the source of the synchronous MOSFET. A high frequency capacitor (typically 1 uF) must be connected from V12 pin to this pin for noise free operation.
25	LGATE	Output driver for the synchronous power MOSFET for the Core supply.
27	UGATE	Output driver for the high side power MOSFET for the Core supply.
28	V12	This pin is connected to the 12 V supply and serves as the power Vcc pin for the output drivers. A high frequency capacitor (typically 1 uF) must be placed close to this pin and PGND pin and be connected directly from this pin to the GND plane for the noise free operation.
20	V5	5V supply voltage. A high frequency capacitor (0.1 to 1 uF) must be placed close to this pin and connected from this pin to the GND plane for noise free operation.
11	Select	This pin provides automatic voltage selection for the AGP switching regulator. When it is pulled LO, the voltage is 1.5V and when left open or pulled to HI, the voltage is 3.3V.
2	FIX	Leaving this pin open provides fixed output voltages of the 1.5V and 1.8V for the #3 and #4 linear regulators. When this pin is grounded the reference to the linear regulators are set to 1.26V and therefore the output of the regulators can be programmed to any voltages above the 1.26V using; $V_{out}=1.26*(1+R_{top}/R_{bot})$ Where: Rtop=Top resistor connected from the output to the Vsense pin Rbot=Bottom resistor connected from the Vsense pin to ground.

US3021B

BLOCK DIAGRAM

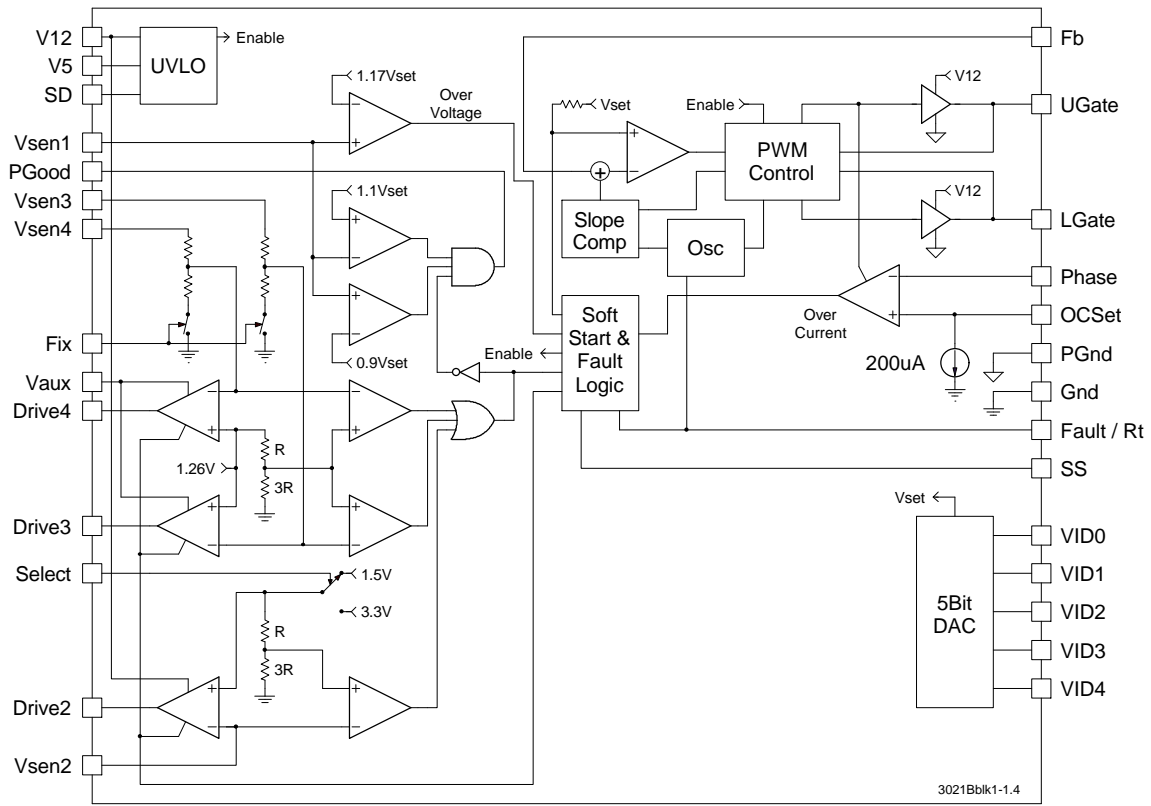

Figure 1 - Simplified block diagram of the US3021.

TYPICAL APPLICATION
(Dual Layout with HIP6021)

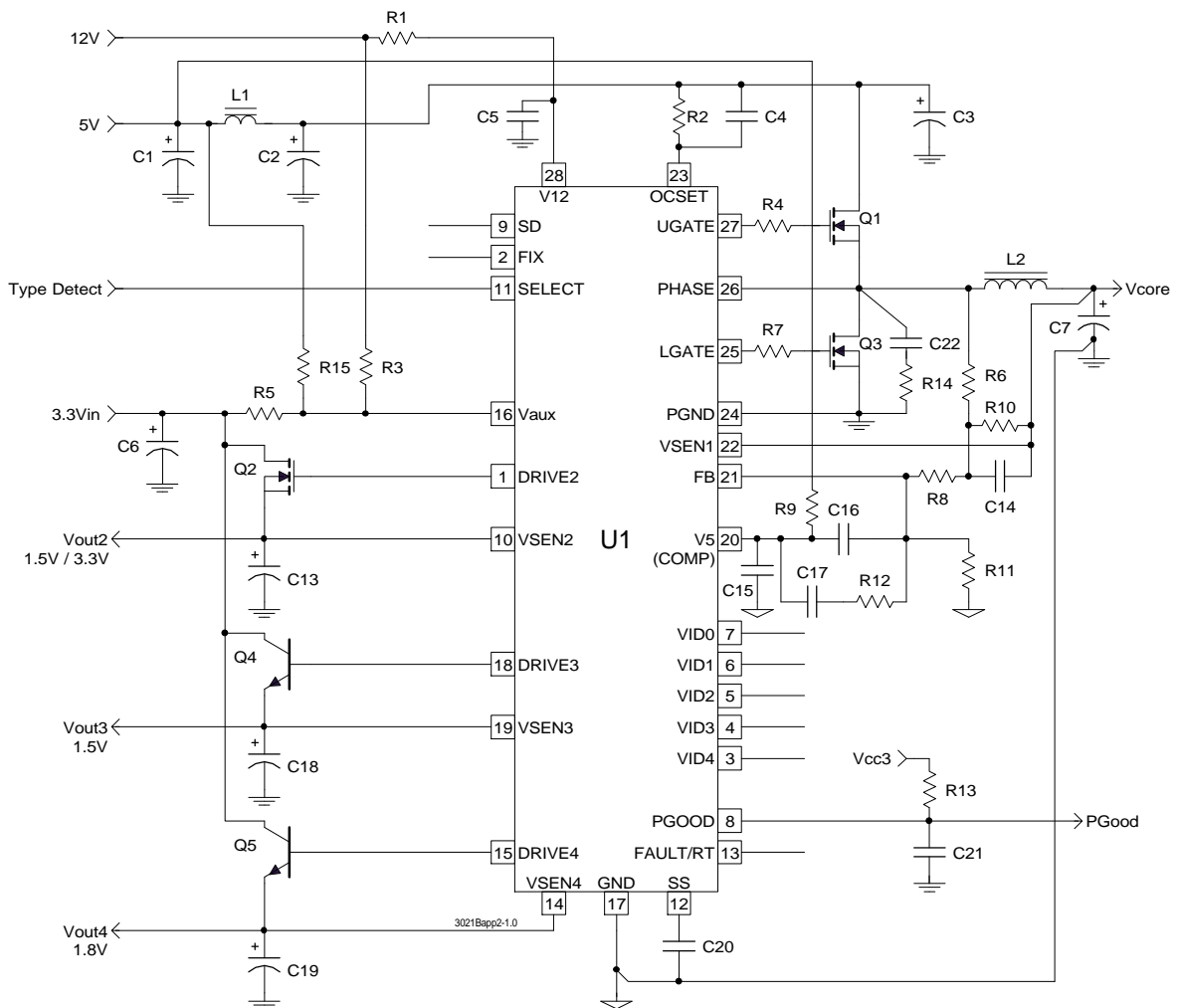

Figure 2 - Typical application of US3021B in a dual layout with HIP6021 for an on board DC-DC converter providing power for the Vcore , GTL+, 1.8V chip set supply as well as auto select AGP supply for the next generation PC applications.

Part#	R3	R5	R9	R10	R15	C15	C16	C17
HIP6021	O	S	O	V	O	O	V	V
US3021B	O	O	O	O	S	V	O	O

S - Short O - Open V - See Unisem or Harris parts list for the value.

Table 2 - Dual layout component table

Note 1: If Q4 and Q5 are changed to MOSFETs such as IRLR024, then R2 is short and R4 is open.

US3021B

US3021M Application Parts List Dual Layout with HIP6021

Ref Desig	Description	Qty	Part #	Manuf
Q1	MOSFET	1	IRL3103S, TO263 package	IR
Q2	MOSFET	1	IRLR3103, TO252 package	IR
Q3	MOSFET with Schottky	1	IRL3103D1S, TO263 package	IR
Q4,5	Transistor	2	2SD1760, TO252 package	ROHM
L1	Inductor	1	L=1uH, 5052 core with 4 turns of 1.0mm wire	Micro Metal
L2	Inductor	1	L=2.7uH, 5052B core with 7 turns of 1.2mm wire	Micro Metal
C1	Capacitor, Electrolytic	1	10MV470GX, 470uF,10V	Sanyo
C2,3	Capacitor, Electrolytic	2	10MV1200GX, 1200uF,10V	Sanyo
C4	Capacitor, Ceramic	1	220pF, 0603	
C5	Capacitor, Ceramic	1	1uF, 0805	
C6,18	Capacitor, Electrolytic	2	6MV1000GX, 1000uF,6.3V	Sanyo
C7	Capacitor, Electrolytic	6	6MV1500GX, 1500uF,6.3V,	Sanyo
C13,19	Capacitor, Electrolytic	1	6MV1500GX, 1500uF,6.3V,	Sanyo
C14,15	Capacitor, Ceramic	2	1uF, 0603	
C16,17	Capacitor, Ceramic	2	See Table 2, dual layout component 0603 * 2	
C20,21	Capacitor, Ceramic	2	0.1uF, 0603	
C22	Capacitor, Ceramic	1	1000pF, 0603	
R1	Resistor	1	10Ω, 5%, 0603	
R2	Resistor	1	3.3kΩ, 5%, 0603	
R3,5,12	Resistor	3	See Table 2, dual layout component 0603 * 3	
R4,7,14	Resistor	3	4.7Ω, 5%, 1206	
R6,8,10	Resistor	3	2.2kΩ, 1%, 0603	
R9	Resistor	1	0Ω, 0603	
R11	Resistor	1	220kΩ, 1%, 0603	
R13	Resistor	1	10kΩ, 5%, 0603	
R15	Resistor	1	0Ω, 0603	