

Features and Benefits

- ESD Tolerance IC > 7,000V
- ESD Tolerance of Fan > 15,000V
- Built-in Reverse Voltage Protection
- Built-in RFI Filter
- Power Efficient CMOS and Power MOSFET Drivers allow 400mA without overheating
- Built-in Zener Diodes Protect Outputs
- Eliminates all Fan Components
- Eliminate PC Board
- 5V and 12V Operation
- High Sensitivity for switching symmetry
- Locked Rotor Shutdown

Applications

- Fan Sizes up to 90mm
- Current Range up to 400mA

Ordering Information

Part No.	Temperature Suffix	Package	Temperature Range
US79	K	UA	-40°C to 125°C
US79	K	8-Pin Narrow SOIC	-40°C to 125°C

Functional Diagram

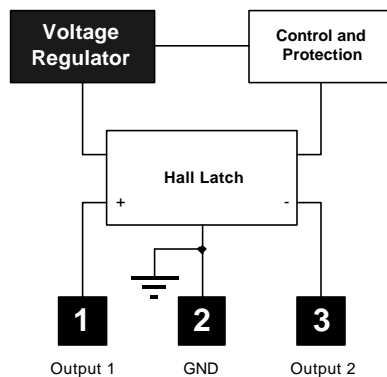

Description

The US79KUA is the most advanced Smart Fan Control Hall IC. It is designed for 5V and 12V cooling commutation. The chip contains many features to allow survival in a harsh environment. The IC was designed to eliminate all discrete components such as capacitors, resistors, transistors, diodes, PC board and associated labor, replacing US\$0.25 to US\$0.35 in direct cost.

The K rating guarantees proper operation up to an ambient temperature of 125°C. Hall IC circuitry and power FET output provide a low power dissipation cool chip.

Locked Rotor conditions are detected by the IC when there is no motion for one second and will shut off the motor drive for five seconds. Then, the IC will turn on the drive current for one second. This sequence continues indefinitely until the locked rotor condition is fixed. This feature prevents overheating. Maximum ambient temperature is determined by driver power dissipation. For instance, at 125°C ambient, driver power cannot exceed 125mW or 250mA. Future versions will offer optional features.

US79 Electrical Specifications

DC operating parameters: $T_A = 25$ to 125°C , $V_{DD} = 5.0$ to 12V unless otherwise specified.

Parameter	Test Conditions		Min	Typ	Max	Units
Supply Voltage	V_{DD}	Operating	3.7	-	18	V
Supply Current	I_{DD}	Operating	1.2	2.0	4	mA
Output leakage	I_{LEAK}	$B < B_{OP}$	-	1	10	μA
Output voltage	V_{OUT}	$B < B_{HYS}$	-	-	35	V
Output Saturation voltage	V_{DSS}	$I_{OUT} = 150\text{mA}$, $V_{DD} = 12\text{V}$		400	600	mV
Output Saturation voltage	V_{DSS}	$I_{OUT} = 350\text{mA}$, $V_{DD} = 12\text{V}$		800	1100	mV
Output On resistance	R_{DDSS}	$V_{DD} = 12\text{V}$		1.34		Ω
Thermal resistance	R_{th}	Operating			200	$^\circ\text{C/Watt}$

US79 Magnetic Specifications

DC operating parameters: $T_A = 25$ to 125°C , $V_{DD} = 5.0$ to 12V unless otherwise specified. $1\text{ mT} = 10\text{ Gauss}$.

Parameter	Symbol	Test Conditions	Min	Typ	Max	Units
Operate Point	B_{OP}	Operating		3.0	6.0	mT
Release Point	B_{RP}	Operating	-6.0	-3.0		mT
Hysteresis	B_{HYS}	Operating	-	6.0	-	mT

General Description

The US79 eliminates 16 solder joints, protects against ESD, filters RFI emission caused by switching of high currents, protects against voltage surges, protects against locked rotor, operates at a low temperature and is manufactured in an Automotive IC factory.

Unique Features

Reverse voltage protection eliminates the need for a diode. Reverse current flows through the coils and the chip. Power dissipation is $(2 * I_{start} * 0.7\text{V})$. Table 1 presents max temperature for each current.

Table 1

I_{start} / I_{start}	T_A Maximum Rev V Test
100mA	125°C
200mA	100°C
300mA	70°C
400mA	40°C

The IC tolerates $>7000\text{V}$ ESD. When installed in the fan, the windings increase the ESD tolerance to $>15000\text{V}$ eliminating the need for ESD concerns in the finished fan. Reverse Voltage protection is provided by the motor windings. The IC contains slew rate control on the output drivers to eliminate RF emissions. 35V Zener diodes clamp the output drivers for overstress protection.

Application Comments

EMC protection is built in. EMC considerations require that the fan assembly should tolerate ESD, reverse voltage, over voltage and not radiate RF noise which may interfere with other electronic equipment. These capabilities are built in to the chip to meet EMC requirements.

Qualification Test Results

SOA (Safe Operating Area) tests to verify inductive switching of 500mA @ 20V . 1000 pieces tested 100 cycles each. Operating Life Test at $T_A = 150\text{C}$ for 4000 hrs. 100pc. "0" failures. Package qualified to QS900 automotive PPAP specifications.

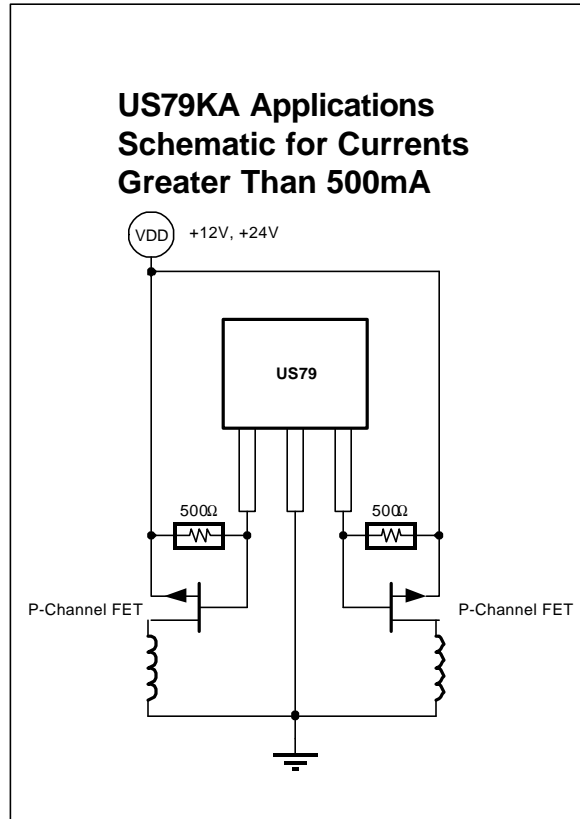
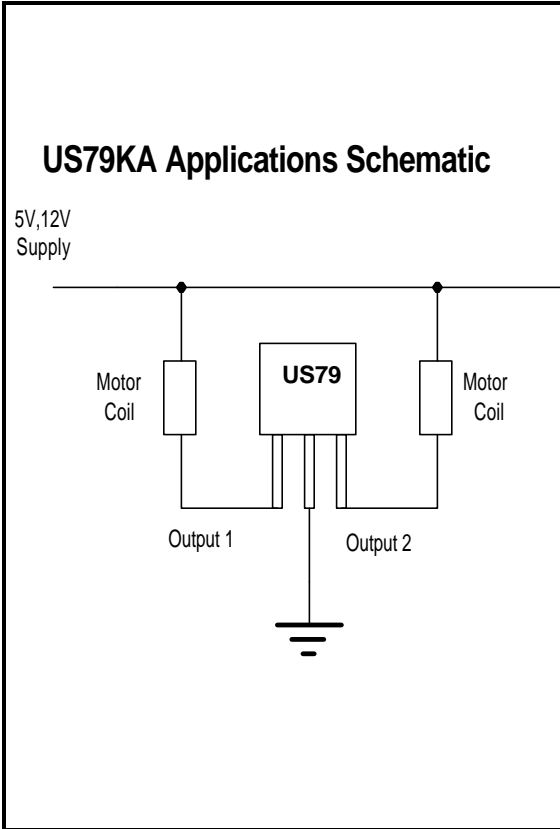

Absolute Maximum Ratings

Supply Voltage (Over Voltage), V_{DD}	18V
Output Current (Fault), I_{OUT}	500mA
Operating Temperature Range, T_A	-40 to 125°C
Storage Temperature Range, T_S	-55 to 165°C
Maximum Junction Temp, T_J	150°C
ESD Sensitivity	+/- 7KV

US79 Hall Plate / Chip Location

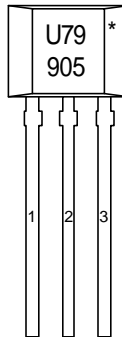
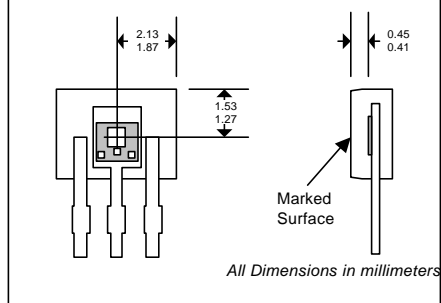

* MARKING:
 Line 1:
 1st digit (U) = Supplier (Melexis)
 2nd and 3rd digits (79) = Series (79xx)

Line 2:
 1st digit (9) = Year (1999)
 2nd and 3rd digits (05) = Week of Year

PINOUT:
 Pin 1 Output 1
 Pin 2 GND
 Pin 3 Output 2

Melexis Inc. reserves the right to make changes without further notice to any products herein to improve reliability, function or design. Melexis does not assume any liability arising from the use of any product or application of any product or circuit described herein.

UA Package Dimensions

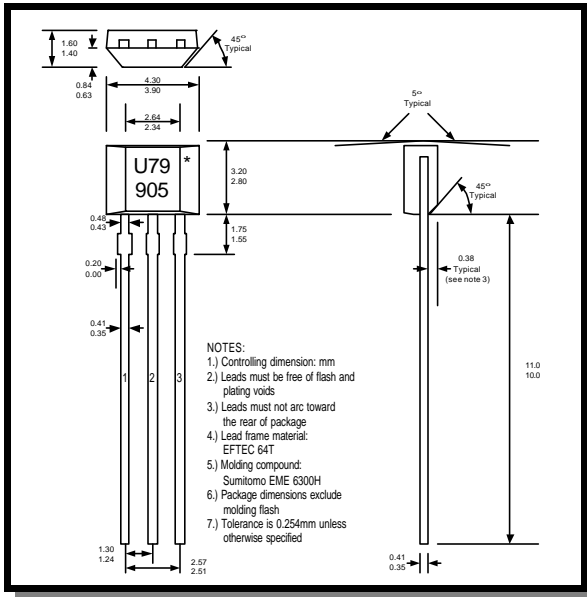

For the latest version of this document,
 Go to our website at:
www.melexis.com
 Or for additional information, contact Melexis directly:

USA

Melexis Inc.
 41 Locke Road, Concord, NH 03301
 Phone: +1 603 223 2362 Fax: +1 603 223 9614
 E-mail: sales_usa@melexis.com

United Kingdom

Silicon Concepts
 PCB Lynchborough Road, Hampshire GU30 7SB, United Kingdom
 Phone: +44 1428 751 617 Fax: +44 1428 751 603
 E-mail: sales_uk@melexis.com

Germany

Am Seestern 8, 40547 Düsseldorf, Germany
 Phone: +49 211 5360212 Fax: +49 211 5360250
 E-mail: sales_de@melexis.com

France

Melexis France
 Tour Arago, 5 rue Bellini, 92806 Puteaux-La-Défense, France.
 Phone: +33 1 47 78 11 34 Fax: +33 1 47 78 06 35
 E-mail: sales_france@melexis.com

Italy

Dimacred IRL
 Via Papa Giovanni XXIII no. 25, 20046 Biassono, Italy
 Phone: +39 039 249 4856 Fax: +39 039 491773
 E-mail: sales_italy@melexis.com

Japan

Satori Electric Co., LTD
 1-14-10 Shiba, Minato-Ku, Tokyo, Japan
 Phone: +81 3 3452 7171 Fax: +81 3 3769 2197
 E-mail: sales_japan@melexis.com

Taiwan

Beechwood Int'l Taiwan Co.
 Room 8, 17F, No. 189, Taipei, Taiwan
 Phone: +886 2 2739 3322 Fax: +886 2 2739 3090
 E-mail: sales_taiwan@melexis.com

8-Pin Narrow SOIC Package Dimensions

