

Low Capacitance 2-Line ESD Protection

Features

- Ultra low leakage: nA level
- Operating voltage: 5V
- Low clamping voltage
- Complies with following standards:
 - IEC 61000-4-2 (ESD) immunity test
 - Air discharge: ±30kV
 - Contact discharge: ±30kV
 - IEC61000-4-4 (EFT) 40A (5/50ns)
 - IEC61000-4-5 (Lightning) 6A (8/20µs)
- RoHS Compliant

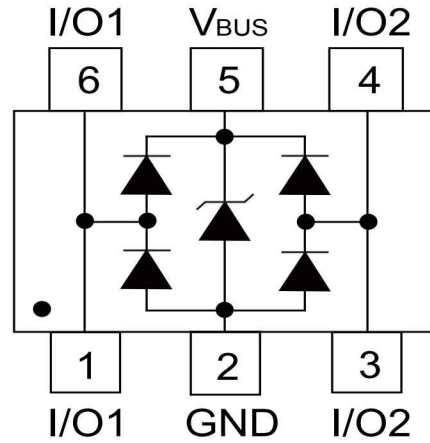

Applications

- USB 2.0 interface
- 10/100 Ethernet
- Personal digital assistants (PDA's)
- Notebooks, Desktops and Servers
- Portable instrumentation
- Digital cameras

Mechanical Characteristics

- Package: SOT23-6 Lead
- Finish: Matte Tin
- UL Flammability Classification Rating 94V-0
- Pb-Free, Halogen Free, RoHS/WEEE Compliant

Absolute Maximum Ratings (T_A=25°C unless otherwise specified)

Parameter	Symbol	Value	Unit
Peak Pulse Power (8/20µs)	P _{pk}	150	W
Peak Pulse Current (8/20µs)	I _{pp}	6	A
ESD per IEC 61000-4-2 (Air)	V _{ESD}	±30	kV
ESD per IEC 61000-4-2 (Contact)		±30	
Operating Temperature Range	T _J	-55 to +125	°C
Storage Temperature Range	T _{stg}	-55 to +150	°C

Low Capacitance 2-Line ESD Protection

Electrical Characteristics ($T_A=25^{\circ}\text{C}$ unless otherwise specified)

Parameter	Symbol	Test Condition	Min	Typ	Max	Unit
Reverse stand-off voltage	V_{RWM}				5	V
Reverse breakdown voltage	V_{BR}	$I_{BR}=1\text{mA}$	6		9	V
Reverse leakage current	I_R	$V_R=5\text{V}$			0.1	μA
Clamping voltage ($t_p=8/20\mu\text{s}$)	V_C	$I_{PP}=1\text{A}$			10	V
Clamping voltage ($t_p=8/20\mu\text{s}$)	V_C	$I_{PP}=6\text{A}$			15	V
Junction capacitance	C_J	0Vdc, f=1MHz Between I/O pins and GND		0.8	1	pF
	C_J	0Vdc, f=1MHz I/O to I/O		0.35	0.4	pF

Typical Characteristics

Fig1. 8/20 μ s Pulse Waveform

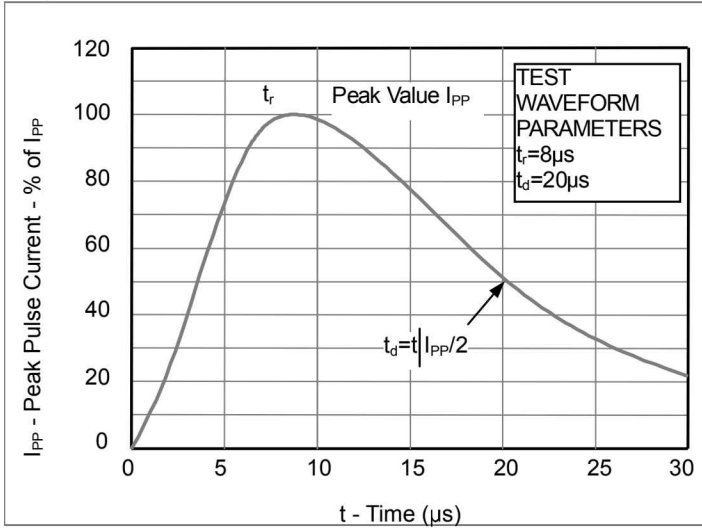

Fig2. ESD Pulse Waveform (according to IEC 61000-4-2)

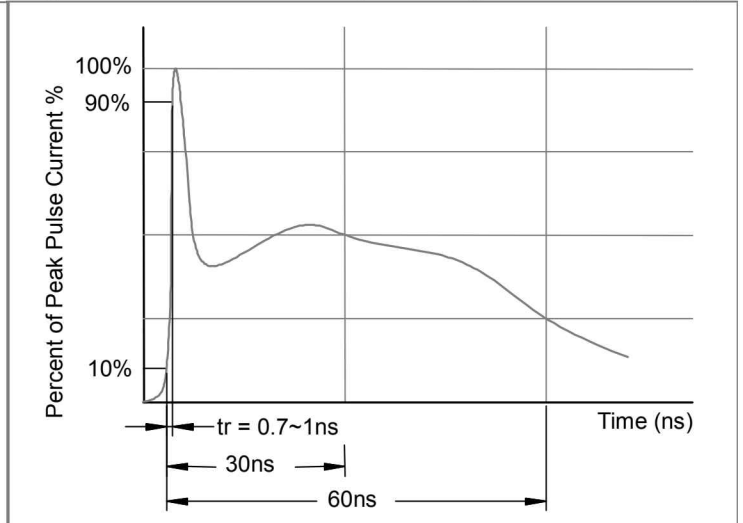
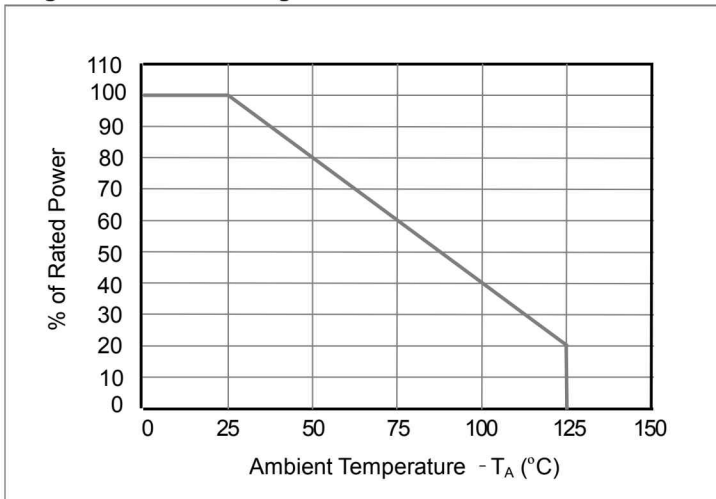
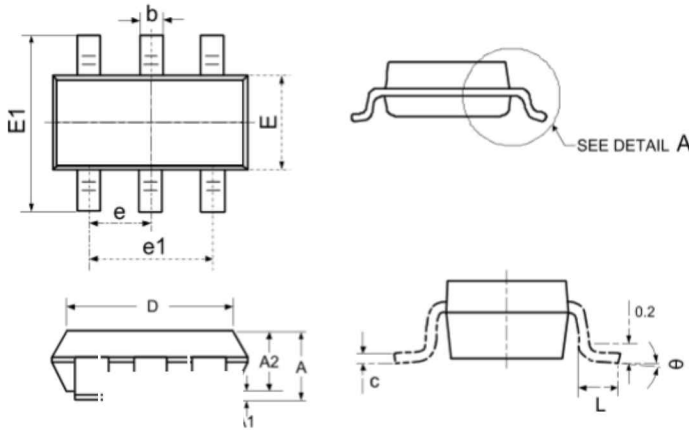

Fig3. Power Derating Curve



Outline Drawing – SOT23-6



Symbol	Dimensions (mm)	
	Min	Max
A	1.050	1.250
A1	0.000	0.100
A2	1.050	1.150
D	2.820	3.020
E	1.500	1.700
E1	2.650	2.950
b	0.300	0.500
e	0.950 (BSC)	
e1	1.800	2.000
L	0.300	0.600
θ	0°	8°

Marking

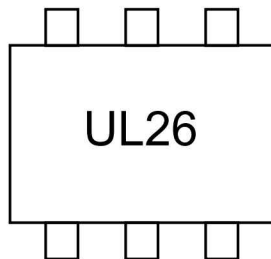

Ordering information

Order code	Package	Base qty	Delivery mode
UMW USBLC6-2SC6	SOT23-6	3000	Tape and reel