



HIGH PRECISION PSR CONSTANT CURRENT LED DRIVER

DESCRIPTION

The UTC **USL3638** is a high performance, high precision primary-side feedback and regulation and constant current controller for LED lighting, The UTC **USL3638** operates in discontinuous conduction mode for inductor current. It is suitable for flyback convertor under the 90V~264V universal input. The system output power for UTC **USL3638** (SOP8) and UTC **USL3638** (DIP8) is recommended to be less than 8W and 11W.

The UTC **USL3638** integrates 650V power MOSFET. Since adopting primary sense and feedback control technology, the secondary sense and feedback circuit is eliminated. The loop compensation components are also removed while maintaining stability overall operating conditions. Low operating current, and using particular driver architecture and demagnetization sensing technology make the auxiliary winding for sensing the output current and supplying the chip also needless. The low component counts and small system size are realized.

Since using the proprietary high accurate current sense method, the UTC **USL3638** realizes $\pm 5\%$ accuracy of LED current along with excellent line and load regulation.

The UTC **USL3638** has integrated rich protection functions including LED short/open circuit protection, CS resistor short circuit protection, over-temperature protection, V_{CC} under voltage protection. The industry leading OVP voltage accuracy ensures the best LED open circuit protection.

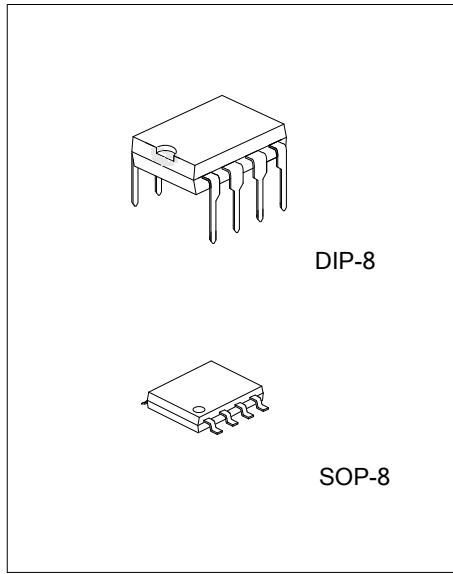

FEATURES

- * Built-in 650V Power MOSFET
- * No Auxiliary winding for sensing and supplying
- * Constant current control without secondary sense and feedback circuit.
- * Ultra low operating current to improve efficiency
- * Universal input voltage
- * $\pm 5\%$ LED current accuracy
- * Choice for maximum duty cycle and OVP voltage
- * CS resistor short circuit protection
- * LED short and open circuit protection
- * Over temperature protection
- * V_{CC} under-voltage protection

ORDERING INFORMATION

Ordering Number		Package	Packing
Lead Free	Halogen Free		
USL3638L-S08-R	USL3638G-S08-R	SOP-8	Tape Reel
USL3638L-D08-T	USL3638G-D08-T	DIP-8	Tube

<p>USL3638G-S08-R</p> <p>(1)Packing Type</p> <p>(2)Package Type</p> <p>(3)Green Package</p>	<p>(1) R: Tape Reel, T: Tube</p> <p>(2) S08: SOP-8, D08: DIP-8</p> <p>(3) G: Halogen Free and Lead Free, L: Lead Free</p>
---	---

MARKING

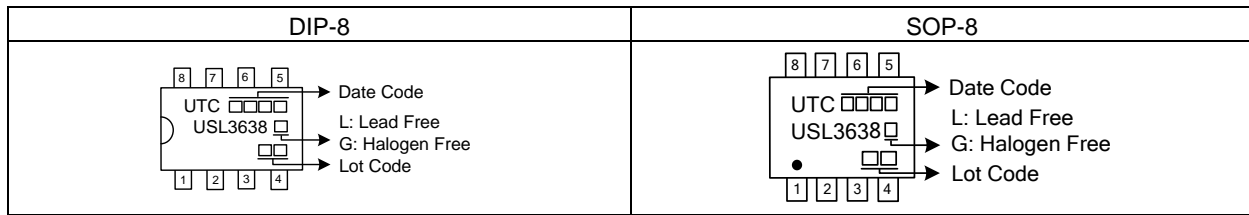

PIN CONFIGURATION

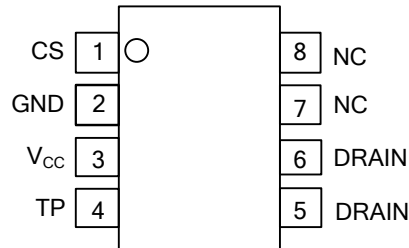

PIN DESCRIPTION

PIN NO.	PIN NAME	DESCRIPTION
1	CS	Current sense. The sense resistor detecting the primary current of transformer is connected between this pin and GND
2	GND	Ground
3	V _{cc}	Power supply
4	TP	Test point, must be floated
5, 6	DRAIN	Internal high voltage MOSFET Drain
7, 8	NC	No connection, must be floated

■ BLOCK DIAGRAM

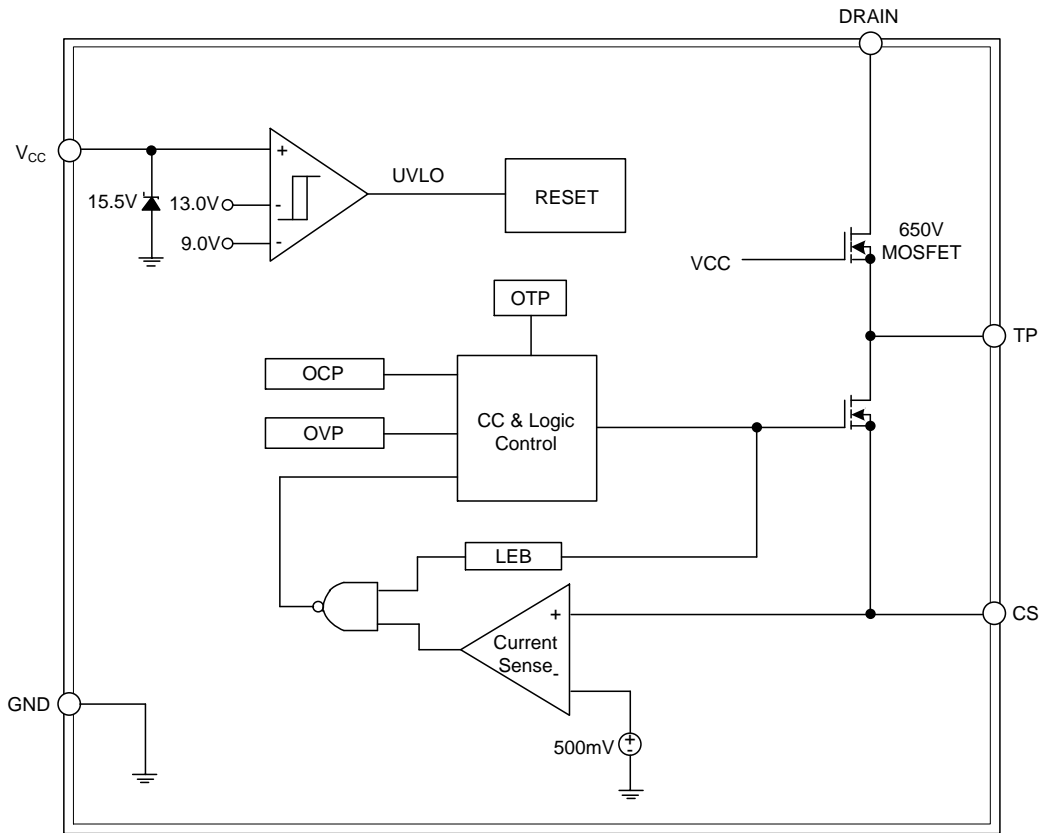

■ **ABSOLUTE MAXIMUM RATING**

PARAMETER	SYMBOL	RATINGS	UNIT
V _{CC} Pin Maximum Sink Current	I _{CC_MAX}	5	mA
Internal HV MOSFET Drain Voltage	DRAIN	-0.3 ~ 650	V
Current Sense Pin Input Voltage	CS	-0.3 ~ 6	V
Internal HV MOSFET Source Voltage	TP	-0.3 ~ 20	V
Power Dissipation	P _{DMAX}	0.45	W
Operating Temperature	T _{OPR}	-40 ~ +105	°C
Junction Temperature	T _J	-40 ~ +150	°C
Storage Temperature	T _{STG}	-55 ~ +150	°C

Note: Absolute maximum ratings are those values beyond which the device could be permanently damaged. Absolute maximum ratings are stress ratings only and functional device operation is not implied.

■ **RECOMMENDED OPERATION CONDITIONS**

PARAMETER	SYMBOL	RATINGS	UNIT
Output Power SOP-8 (Input Voltage 170V~265V)	P _{OUT1}	<8	W
Output Power SOP-8 (Input Voltage 85V~265V)	P _{OUT2}	<7	W
Output Power DIP-8 (Input Voltage 170V~265V)	P _{OUT3}	<11	W
Output Power DIP-8 (Input Voltage 85V~265V)	P _{OUT4}	<10	W
System Operating Frequency	F _{OP}	52	KHz

■ **THERMAL RESISTANCES CHARACTERISTICS**

PARAMETER	SYMBOL	RATING	UNIT	
Junction to Ambient	θ_{JA}	DIP-8	180	°C/W
		SOP-8	145	°C/W

■ **ELECTRICAL CHARACTERISTICS** (Notes 1, 2) (Unless otherwise specified, $V_{CC}=14V$ and $T_A=25^{\circ}C$)

PARAMETER	SYMBOL	TEST CONDITIONS	MIN	TYP	MAX	UNIT
Supply Voltage Section						
V_{CC} Clamp Voltage	V_{CC_Clamp}	1mA		15.5		V
Turn On Threshold Voltage	V_{CC_ON}	V_{CC} Rising		13.0		V
Turn Off Threshold Voltage	V_{CC_UVLO}	V_{CC} Falling		9.0		V
V_{CC} Startup Current	I_{ST}	$V_{CC}=V_{CC_ON}-1V$		45	80	μA
V_{CC} Operating Current	I_{OP}			130	300	μA
Current Sense Section						
Threshold Voltage for Peak Current Limit	V_{CS_TH}		485	500	515	mV
Leading Edge Blanking Time for Current Sense	T_{LEB}			500		ns
Switch Off Delay Time	T_{DELAY}			200		ns
Switching Frequency						
Minimum Working Frequency	F_{MIN}			5		KHz
Maximum Duty Cycle						
Maximum Duty Cycle	D_{MAX}	IC temperature < 150°C		50		%
		IC temperature > 150°C		25		%
MOSFET Section						
Static Drain-Source On-Resistance	$R_{DS(ON)}$	$V_{GS}=14V, I_{DS}=0.5A$		6		Ω
Drain-Source Breakdown Voltage	BV_{DSS}	$V_{GS}=0V, I_{DS}=250\mu A$	650			V
Drain-Source Leakage Current	I_{DSS}	$V_{GS}=0V, V_{DS}=650V$			10	μA
Maximum Drain Current	I_{DMAX}	$V_d=6V$	0.65	0.75		A
Output Over Voltage Protection						
Minimum Discharge Time	T_{DIS_MIN}			7.1		μS
OVP System Frequency	F_{OVP}			70		KHz
Over Temperature Protection						
Thermal Protect Threshold	T_{PRO}			150		$^{\circ}C$
Thermal Protect Hysteresis	T_{PRO_HYS}			25		$^{\circ}C$

Notes: 1. Production testing of the chip is performed at 25°C.

2. The maximum and minimum parameters specified are guaranteed by test, the typical value are guaranteed by design, characterization and statistical analysis.

■ FUNCTION DESCRIPTION

The UTC **USL3638** is a high performance power switch specially designed for LED lighting. Benefit from an integrated 650V power MOSFET and its peculiar technology for constant current control, the accurate LED current can be realized without opto-coupler, TL431 feedback circuit and auxiliary winding which minimizing the external component count and lowering the total bill of material cost.

Start Up

The start-up current in UTC **USL3638** is designed to as low as 60μA. The V_{CC} capacitor will be charged through the start-up resistor when the system is powered on. Once the V_{CC} voltage reaches the start-up threshold, the UTC **USL3638** will start to switch. The UTC **USL3638** integrates a 15V V_{CC} clamping circuit. Due to the ultra-low operating current, the auxiliary winding is not needed to supply the IC.

Constant Current Control

The CS is connected to the inside current sense comparator and the voltage on CS will be compared with the internal 500mV reference voltage. The output of this comparator includes a 500nS leading edge blanking time. Once the voltage on CS reaches the threshold, the power MOSFET will be switched off until the control circuit generates an 'ON' signal. Above current sense process will be present in each cycle.

The primary peak current is given by:

$$I_{P_PK} = \frac{500}{R_{CS}} \text{ (mA)}$$

The current in LED can be calculated by the equation:

$$I_{OUT} = \frac{I_{P_PK}}{2} \times \frac{N_P}{N_S} \times \frac{T_{DIS}}{T}$$

Where,

N_P: primary winding turns of transformer

N_S: secondary winding turns of transformer

I_{P_PK}: peak current in MOSFET

T_{DIS}/T: ratio of secondary discharge time and switching period, or duty cycle.

Power MOSFET

The UTC **USL3638** integrates a 650V power N-MOSFET. It can minimize the external component count and reduce the BOM cost and PCB size.

The UTC **USL3638** uses SOP-8 package. The recommended system output power is below 5W in universal input (85V~265V) application.

Operating Switching Frequency

The UTC **USL3638** is designed to work in discontinuous conduction mode and no external loop compensation component is required while maintaining stability. The maximum duty cycle is limited to 50%. The maximum switching frequency at normal operation is suggested to set around 52KHz. If the maximum frequency is set too high, it will affect the number of maximum series LED lamps. If set too low, the LED open circuit voltage will be too high.

The maximum and minimum switching frequency is limited in UTC **USL3638** to ensure the stability of system.

The switching frequency can be set by the formula:

$$f = \frac{D_{MAX}^2 \times N_P^2 \times V_{LED}}{2 \times N_S^2 \times L_P \times I_{LED}}$$

Where, L_P is the primary winding inductance of transformer.

■ FUNCTION DESCRIPTION(Cont.)**Protection Function**

The UTC **USL3638** offers rich protection functions, LED short/open protection, CS resistor short circuit protection, V_{CC} under voltage protection, over temperature protection, and so on. When the LED is open circuit, it will trigger over-voltage protection logic and latch, the system stops switching immediately.

When the LED short circuit is detected, the system works at low frequency ($F_{op}=5\text{KHz}$), so the power consumption is low. At some catastrophic fault condition, such as shorted CS resistor or flyback transformer saturation, the internal fast fault detection circuit will trigger and latch, the system stops switching immediately.

After the system enters into fault latch condition, the V_{CC} voltage will fall until it reaches UVLO threshold. Then the system will re-start again. If the fault condition is removed, the system will recover to normal operation

The thermal shutdown circuitry in the UTC **USL3638** senses the die temperature after start up, and the thermal protection threshold is set to 150°C with a 25°C hysteresis. When the temperature on die of UTC **USL3638** rises and reaches the threshold, the output current will be reduced by half immediately until the temperature on die falls 25°C from thermal protection trigger point.

PCB Layout

The following rules should be followed in UTC **USL3638** PCB layout:

Bypass Capacitor

The bypass capacitor on V_{CC} should be as close as possible to the V_{CC} pin and GND pin.

Ground Path

The power ground path for current sense should be short, and the power ground path should be separated from small signal ground path before the negative of the bulk capacitor.

The Area of Power Loop

The area of main current loop should be as small as possible to reduce EMI radiation, such as the primary current loop, the snubber circuit and the secondary rectifying loop.

TP and NC Pin

The TP and NC pin must be left floating to satisfy the requirement of creepage distance.

Drain pin

To increase the copper area of drain for thermal consideration.

■ TYPICAL APPLICATION CIRCUIT

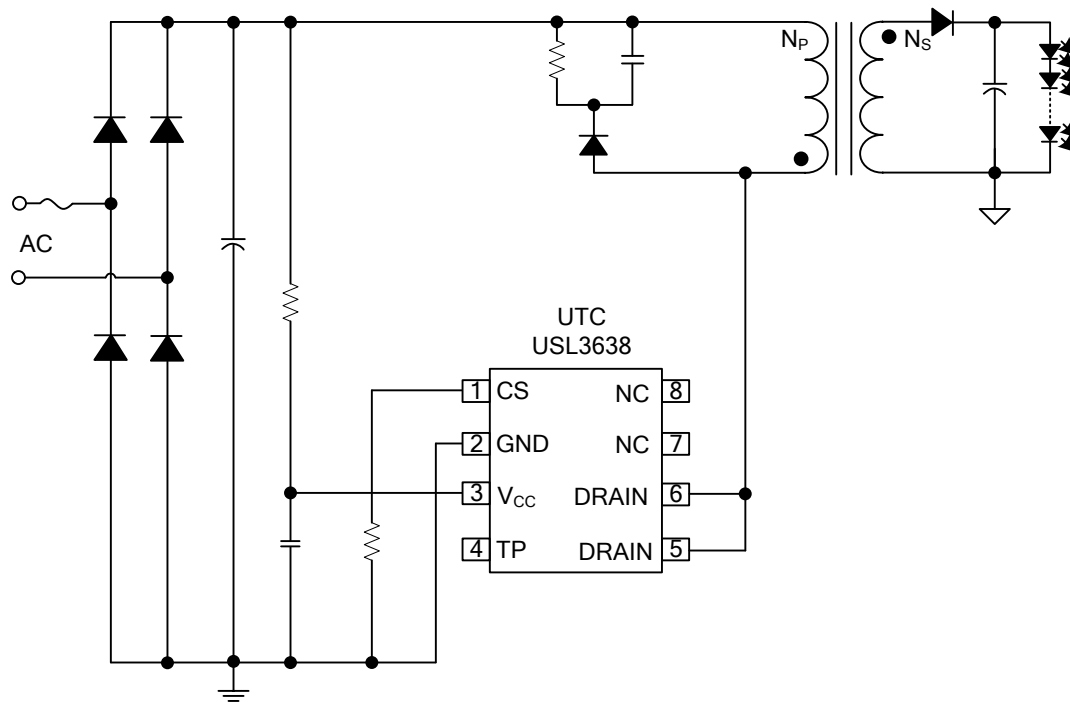

UTC assumes no responsibility for equipment failures that result from using products at values that exceed, even momentarily, rated values (such as maximum ratings, operating condition ranges, or other parameters) listed in products specifications of any and all UTC products described or contained herein. UTC products are not designed for use in life support appliances, devices or systems where malfunction of these products can be reasonably expected to result in personal injury. Reproduction in whole or in part is prohibited without the prior written consent of the copyright owner. UTC reserves the right to make changes to information published in this document, including without limitation specifications and product descriptions, at any time and without notice. This document supersedes and replaces all information supplied prior to the publication hereof.