

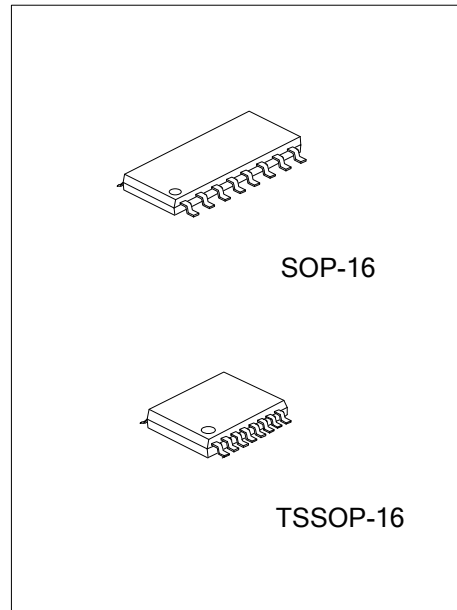

3.0V TO 5.5V LOW POWER MULTICHANNEL RS-232 LINE TRANSCEIVERS USING FOR 0.1µF EXTERNAL CAPACITORS

DESCRIPTION

The UTC **UT3202** has two receivers and two drivers, and a dual charge-pump circuit. The device meets the requirements of TIA/EIA-232-F and provides the electrical interface between an asynchronous communication controller and the serial-port connector. The charge pump and four small external capacitors allow operation from a single 3.0V to 5.5V supply. The device operates at data signaling rates up to 250kbit/s and a maximum of 35V/µs driver output slew rate.



FEATURES

- * Exceeds ±8KV ESD Protection(HBM) for RS-232 I/O Pins
- * Meets the Requirements of TIA/EIA-232-F and ITU V.28 Standards
- * Operates With 3.0V to 5.5V V_{CC} Supply
- * Operates Up To 250kbit/s Data Rate
- * Two Drivers and Two Receivers
- * External Capacitors 4×0.1µF
- * Accepts 5.0V Logic Input With 3.3V Supply

ORDERING INFORMATION

Ordering Number		Package	Packing
Lead Free	Halogen Free		
UT3202L-S16-R	UT3202G-S16-R	SOP-16	Tape Reel
UT3202L-P16-R	UT3202G-P16-R	TSSOP-16	Tape Reel

<p>UT3202G-S16-R</p> <p>(1)Packing Type</p> <p>(2)Package Type</p> <p>(3)Green Package</p>	<p>(1) R: Tape Reel</p> <p>(2) S16: SOP-16, P16: TSSOP-16</p> <p>(3) G: Halogen Free and Lead Free, L: Lead Free</p>
--	--

MARKING

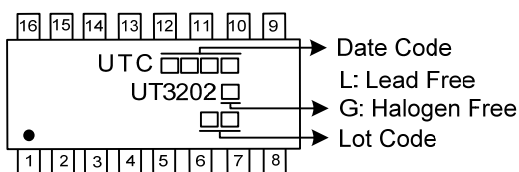

■ PIN CONFIGURATION

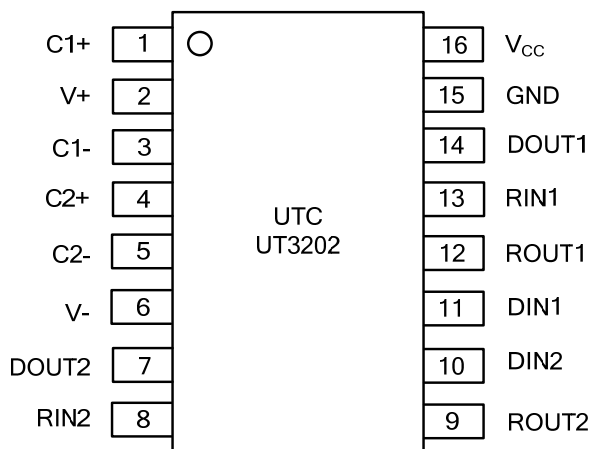

■ PIN DESCRIPTION

PIN NO.	PIN NAME	DESCRIPTION
1	C1+	Positive Terminal of Voltage-Doubler Charge-Pump Capacitor
2	V+	+5.5V Generated by the Charge Pump
3	C1-	Negative Terminal of Voltage-Doubler Charge-Pump Capacitor
4	C2+	Positive Terminal of Inverting Charge-Pump Capacitor
5	C2-	Negative Terminal of Inverting Charge-Pump Capacitor
6	V-	-5.5V Generated by the Charge Pump
7	DOUT2	RS-232 Driver Outputs
8	RIN2	RS-232 Receiver Inputs
9	ROUT2	TTL/CMOS Receiver Outputs
10	DIN2	TTL/CMOS Driver Inputs
11	DIN1	TTL/CMOS Driver Inputs
12	ROUT1	TTL/CMOS Receiver Outputs
13	RIN1	RS-232 Receiver Inputs
14	DOUT1	RS-232 Driver Outputs
15	GND	Ground
16	V _{CC}	+3.0V to +5.5V Supply Voltage

■ BLOCK DIAGRAM

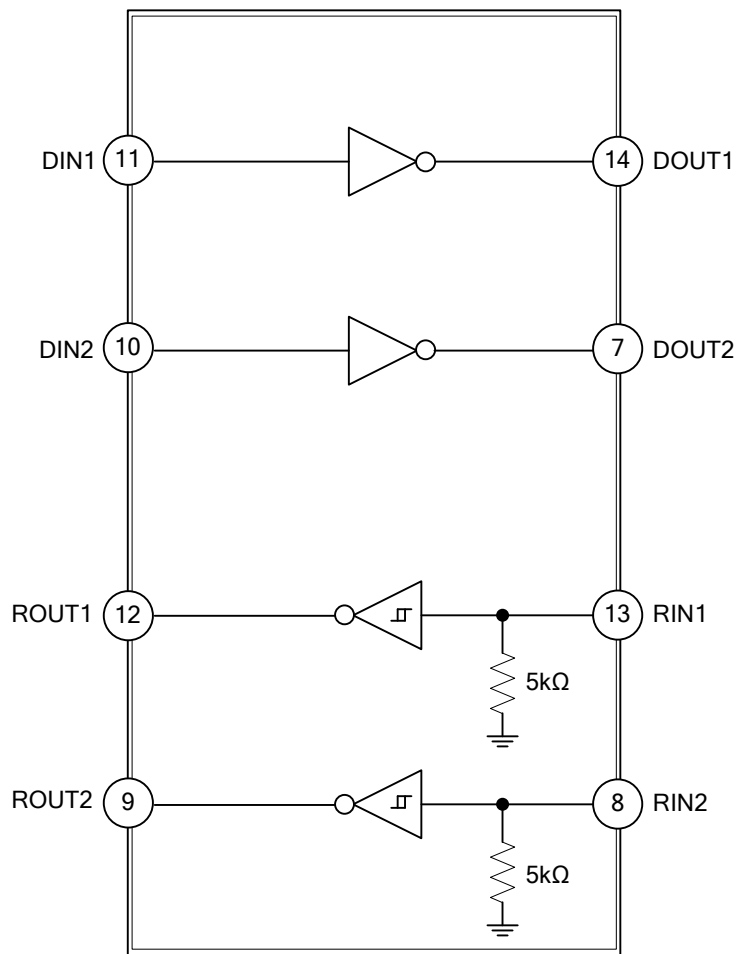

■ **ABSOLUTE MAXIMUM RATING** [Over operating free-air temperature range (unless otherwise noted)]

PARAMETER		SYMBOL	RATINGS	UNIT
Supply Voltage Range		V_{CC}	-0.3 ~ +6.0	V
Positive Output Supply Voltage Range (Note 2)		V+	-0.3 ~ +7.0	V
Negative Output Supply Voltage Range (Note 2)		V-	+0.3 ~ -7.0	V
Supply Voltage Difference (Note 2)		V+ - V-	+13	V
Input Voltage	Drivers	V_{IN}	-0.3 ~ +6.0	V
	Receivers		-25 ~ +25	V
Output Voltage	Drivers	V_{OUT}	-13.2 ~ +13.2	V
	Receivers		-0.3 ~ $V_{CC}+0.3$	V
Operating Virtual Junction Temperature		T_J	+150	°C
Storage Temperature		T_{STG}	-65 ~ + 150	°C

Notes: 1. Absolute maximum ratings are those values beyond which the device could be permanently damaged.

Absolute maximum ratings are stress ratings only and functional device operation is not implied.

2. All voltages are with respect to network GND.

■ **THERMAL DATA**

PARAMETER		SYMBOL	RATING	UNIT
Junction to Ambient	SOP-16	θ_{JA}	105	°C/W
	TSSOP-16		118	

■ **RECOMMENDED OPERATING CONDITIONS** (See Note & Table 1)

PARAMETER	SYMBOL	TEST CONDITIONS	MIN	TYP	MAX	UNIT
Supply Voltage	V_{CC}	$V_{CC}=3.3V$	3.0	3.3	3.6	V
		$V_{CC}=5.0V$	4.5	5.0	5.5	V
Driver and Control High-level Input Voltage	V_{IH}	DIN	$V_{CC}=3.3V$	2.0		V
			$V_{CC}=5.5V$	2.4		
Driver and Control Low-level Input Voltage	V_{IL}	DIN			0.8	V
Driver and Control Input Voltage	V_{IN}	DIN			5.5	V
Logic Pullup Current	I_{IN}	DIN=0V		15	200	μA
Receiver Input Voltage	V_{RIN}		-25		25	V
Operating Free-Air Temperature	T_A		0		70	°C

Notes: Test conditions are C1~C4=0.1μF at $V_{CC}=3.3V\pm 0.3V$; C1=0.047μF, C2~C4=0.33μF at $V_{CC}=5.0V\pm 0.5V$.

■ **ELECTRICAL CHARACTERISTICS** [(over recommended ranges of supply voltage and operating free-air temperature (unless otherwise noted) (see Note 3 & Table 1)]

PARAMETER	SYMBOL	TEST CONDITIONS	MIN	TYP (Note 1)	MAX	UNIT
Supply Current	I_{CC}	No load		0.3	1.0	mA
DRIVER SECTION						
High-Level Output Voltage	V_{OH}	DOUT at $R_L=3k\Omega$ to GND, DIN=GND	+5.0	+5.4		V
Low-Level Output Voltage	V_{OL}	DOUT at $R_L=3k\Omega$ to GND, DIN= V_{CC}	-5.0	-5.4		V
Short-Circuit Output Current (Note 2)	I_{OS}	$V_{CC}=3.6V, V_{OUT}=0V$		± 35	± 60	mA
		$V_{CC}=5.5V, V_{OUT}=0V$		± 35	± 60	mA
Output Resistance	r_O	$V_{CC}, V+$ and $V- =0V, V_{OUT}=\pm 2.0V$	300	10M		Ω
RECEIVER SECTION						
High-Level Output Voltage	V_{OH}	$I_{OH}=-1.0mA$	$V_{CC}-0.6V$	$V_{CC}-0.1V$		V
Low-Level Output Voltage	V_{OL}	$I_{OL}=1.6mA$			0.4	V
Positive-Going Input Threshold Voltage	V_{IT+}	$V_{CC}=3.3V$		1.5	2.4	V
		$V_{CC}=5.0V$		1.8	2.4	V
Negative-Going Input Threshold Voltage	V_{IT-}	$V_{CC}=3.3V$	0.6	1.2		V
		$V_{CC}=5.0V$	0.8	1.5		V
Input Hysteresis	V_{HYS}	$V_{IT+}-V_{IT-}$		0.3		V
Input Resistance	R_I	$V_I=\pm 3.0V\sim\pm 25V$	3	5	7	k Ω

Notes: 1. All typical values are at $V_{CC}=3.3V$ or $V_{CC}=5.0V$, and $T_A=25^\circ C$.

2. Short-circuit durations should be controlled to prevent exceeding the device absolute power-dissipation ratings, and not more than one output should be shorted at a time.

3. Test conditions are $C1\sim C4=0.1\mu F$ at $V_{CC}=3.3V\pm 0.3V$; $C1=0.047\mu F, C2\sim C4=0.33\mu F$ at $V_{CC}=5.0V\pm 0.5V$.

4. Pulse skew is defined as $|t_{PLH}-t_{PHL}|$ of each channel of the same device.

■ **SWITCHING CHARACTERISTICS** [(over recommended ranges of supply voltage and operating free-air temperature (unless otherwise noted) (see Note 3 and Table 1)]

PARAMETER	SYMBOL	TEST CONDITIONS	MIN	TYP (Note 1)	MAX	UNIT
DRIVER SECTION						
Maximum Data Rate		$C_L=1000pF, R_L=3k\Omega$, One Driver Switching	150	250		Kbit/s
Pulse Skew (Note 4)	$t_{SK(P)}$	$C_L=220pF\sim 2500pF, R_L=3k\Omega\sim 7k\Omega$		300		ns
Slew Rate, Transition Region	SR(tr)	$R_L=3k\Omega\sim 7k\Omega, V_{CC}=3.3V$	5		35	V/ μs
		$C_L=220pF\sim 1000pF, C_L=220pF\sim 2500pF$	3		35	
RECEIVER SECTION						
Propagation Delay Time, Low-to High-Level Output	t_{PLH}	$C_L=150pF$		300		ns
Propagation Delay Time, High-to Low-Level Output	t_{PHL}	$C_L=150pF$		300		ns
Output Enable Time	t_{EN}	$C_L=150pF, R_L=3k\Omega$		200		ns
Output Disable Time	t_{DIS}	$C_L=150pF, R_L=3k\Omega$		200		ns
Pulse Skew (Note 4)	$t_{SK(P)}$	$ t_{PLH}-t_{PHL} $		300		ns

Notes: 1. All typical values are at $V_{CC}=3.3V$ or $V_{CC}=5.0V$, and $T_A=25^\circ C$.

2. Short-circuit durations should be controlled to prevent exceeding the device absolute power-dissipation ratings, and not more than one output should be shorted at a time.

3. Test conditions are $C1\sim C4=0.1\mu F$ at $V_{CC}=3.3V\pm 0.3V$; $C1=0.047\mu F, C2\sim C4=0.33\mu F$ at $V_{CC}=5.0V\pm 0.5V$.

4. Pulse skew is defined as $|t_{PLH}-t_{PHL}|$ of each channel of the same device.

■ TYPICAL APPLICATION CIRCUIT

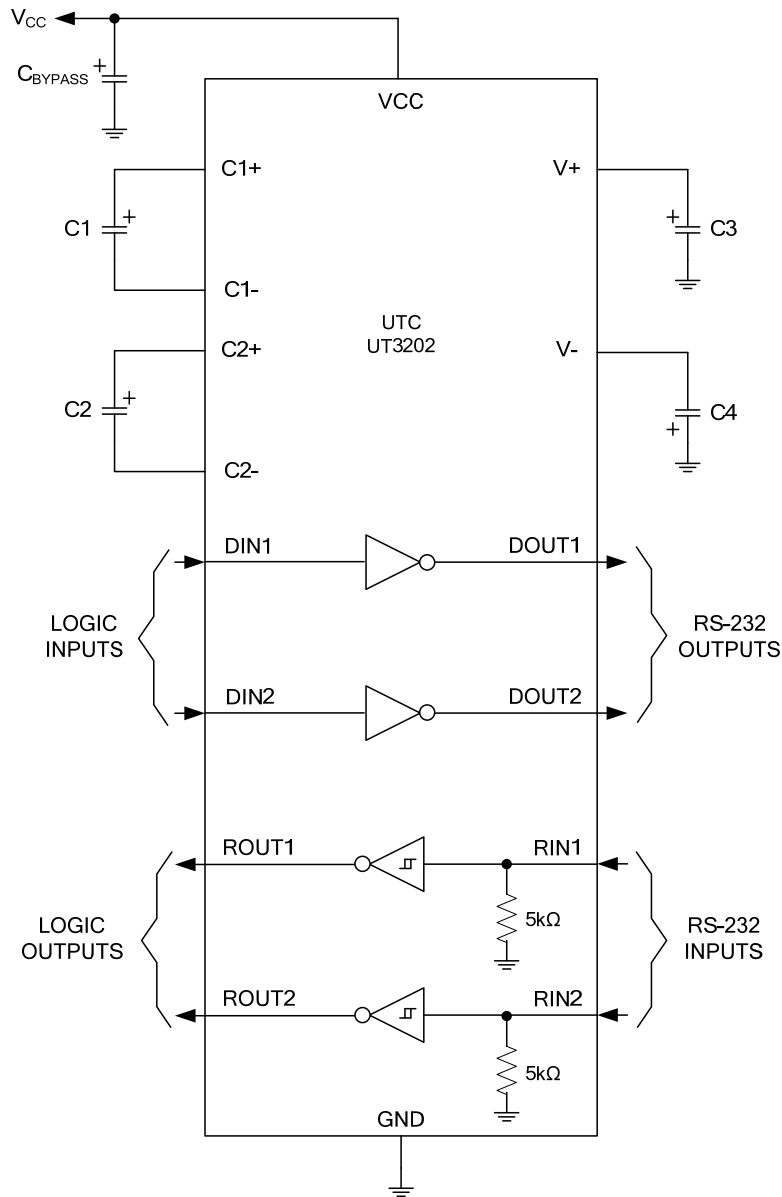

- Notes: 1. C3 can be connected to V_{CC} or GND.
 2. Resistor values shown are nominal.
 3. NC: No internal connection.
 4. Nonpolarized ceramic capacitors are acceptable. If polarized tantalum or electrolytic capacitors are used, they should be connected as shown.

Table1. Typical Operating Circuit and Capacitor Values

V _{CC} (V)	C1 (μF)	C2, C3, C4 (μF)	C _{BYPASS} (μF)
3.0~3.6	0.22	0.22	0.22
3.15~3.6	0.1	0.1	0.1
4.5~5.5	0.047	0.33	0.047
3.0~5.5	0.22	1.0	0.22

UTC assumes no responsibility for equipment failures that result from using products at values that exceed, even momentarily, rated values (such as maximum ratings, operating condition ranges, or other parameters) listed in products specifications of any and all UTC products described or contained herein. UTC products are not designed for use in life support appliances, devices or systems where malfunction of these products can be reasonably expected to result in personal injury. Reproduction in whole or in part is prohibited without the prior written consent of the copyright owner. The information presented in this document does not form part of any quotation or contract, is believed to be accurate and reliable and may be changed without notice.