

UT54ACS164245SEI

Schmitt CMOS 16-bit Bidirectional MultiPurpose Transceiver Datasheet

July, 2010

www.aeroflex.com/16BitLogic



FEATURES

- Flexible voltage operation
 - 5V bus to 3.3V bus; 5V bus to 5V bus
 - 3.3V bus to 5V bus; 3.3V bus to 3.3V bus
- Cold sparing
 - 1MΩ minimum input impedance power-off
- Warm sparing
 - Guaranteed output tri-state while one power supply is "off" and the other is "on"
 - 1MΩ minimum input impedance power-off
- 0.6μm CRH CMOS Technology
- Operational Environment:
 - Total dose: 100 krad(Si)
 - Single Event Latchup immune
- High speed, low power consumption
- Schmitt trigger inputs to filter noisy signals
- Available QML Q or V processes
- Standard Microcircuit Drawing 5962-98580
 - Device Types 06 and 07
- Package:
 - 48-lead flatpack, 25 mil pitch (.390 x .640), wgt 1.4 grams

DESCRIPTION

The 16-bit wide UT54ACS164245SEI MultiPurpose transceiver is built using Aeroflex's CRH technology. This high speed, low power UT54ACS164245SEI transceiver is designed to perform multiple functions including: asynchronous two-way communication, schmitt input buffering, voltage translation, cold and warm sparing. With either or both V_{DD1} and V_{DD2} are equal to zero volts, the UT54ACS164245SEI outputs and inputs present a minimum impedance of 1MΩ making it ideal for "cold spare" applications. Balanced outputs and low "on" output impedance make the UT54ACS164245SEI well suited for driving high capacitance loads and low impedance backplanes. The UT54ACS164245SEI enables system designers to interface 3.3 volt CMOS compatible components with 5 volt CMOS components. For voltage translation, the A port interfaces with the 3.3 volt bus; the B port interfaces with the 5 volt bus. The direction control (DIRx) controls the direction of data flow. The output enable ($\overline{OE}x$) overrides the direction control and disables both ports. These signals can be driven from either port A or B.

The direction and output enable controls operate these devices as either two independent 8-bit transceivers or one 16-bit transceiver.

LOGIC SYMBOL

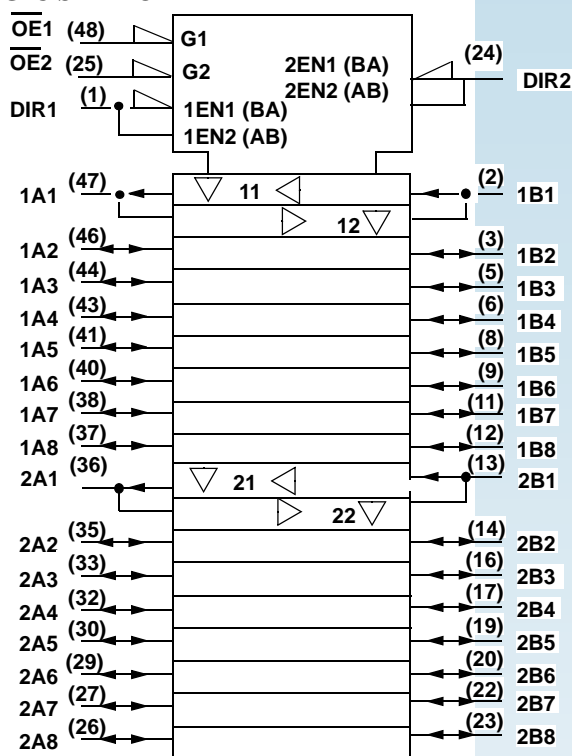

PIN DESCRIPTION

Pin Names	Description
$\overline{\text{OEx}}$	Output Enable Input (Active Low)
DIRx	Direction Control Inputs
xAx	Side A Inputs or 3-State Outputs (3.3V Port)
xBx	Side B Inputs or 3-State Outputs (5V Port)

FUNCTION TABLE

ENABLE $\overline{\text{OEx}}$	DIRECTION DIRx	OPERATION
L	L	B Data To A Bus
L	H	A Data To B Bus
H	X	Isolation

PINOUTS

**48-Lead Flatpack
Top View**

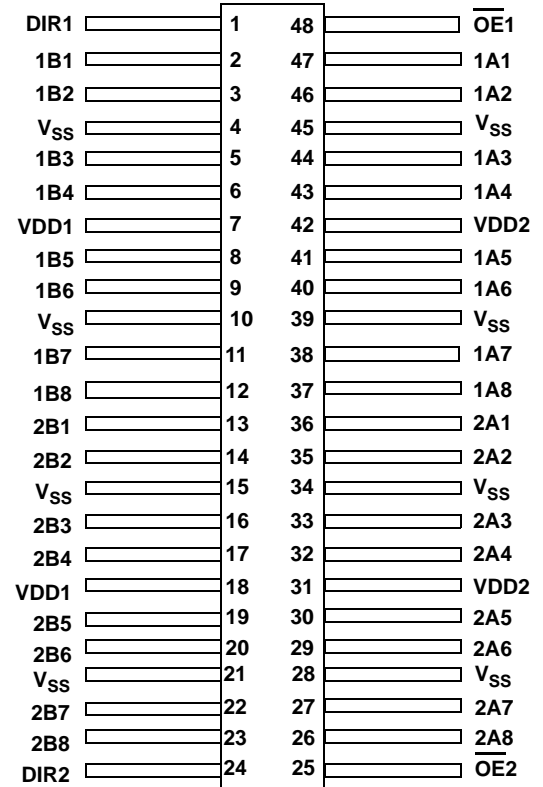

IO GUIDELINES

All inputs are 5 volt tolerant. When VDD2 is at 3.3 volts, either 3.3 or 5 volt CMOS logic levels can be applied to all control inputs. It is recommended that all unused inputs be tied to VSS through a 1KΩ to 10KΩ resistor.

It's good design practice to tie the unused input to VSS via a resistor to reduce noise susceptibility. The resistor protects the input pin by limiting the current from high going variations in VSS.

The number of inputs that can be tied to the resistor pull-down can vary. It is up to the system designer to choose how many inputs are tied together by figuring out the max load the part can drivewhile still meeting system performance specs. Input signal transitions should be driven to the device with a rise and fall time that is <100ms.

POWER TABLE

Port B	Port A	OPERATION
5 Volts	3.3 Volts	Voltage Translator
5 Volts	5 Volts	Non Translating
3.3 Volts	3.3 Volts	Non Translating
V _{SS}	V _{SS}	Cold Spare
V _{SS}	3.3V or 5V	Port A Warm Spare
3.3V or 5V	V _{SS}	Port B Warm Spare

POWER APPLICATION GUIDELINES

For proper operation, connect power to all V_{DD} pins and ground all V_{SS} pins (i.e., no floating V_{DD} or V_{SS} input pins). By virtue of the UT54ACS164245SEI warm spare feature, power supplies V_{DD1} and V_{DD2} may be applied to the device in any order. To ensure the device is in cold spare mode, both supplies, V_{DD1} and V_{DD2} must be equal to V_{SS} +/- 0.3V. Warm spare operation is in effect when one power supply is >1V and the other power supply is equal to V_{SS} +/- 0.3V. If V_{DD1} has a power on ramp longer than 1 second, then V_{DD2} should be powered on first to ensure proper control of DIRx and OEx. During normal operation of the part, after power-up, ensure VDD1 ≥ VDD2.

By definition, warm sparing occurs when half of the chip receives its normal V_{DD} supply value while the V_{DD} supplying the other half of the chip is set to 0.0V. When the chip is "warm spared", the side that has V_{DD} set to a normal operational value is "actively" tri-stated because the chip's internal OE signal is forced low. The side of the chip that has V_{DD} set to 0.0V is "passively" tri-stated by the cold spare circuitry. In order to minimize transients and current consumption, the user is encouraged to first apply a high level to the OEx pins and then power down the appropriate supply.

LOGIC DIAGRAM

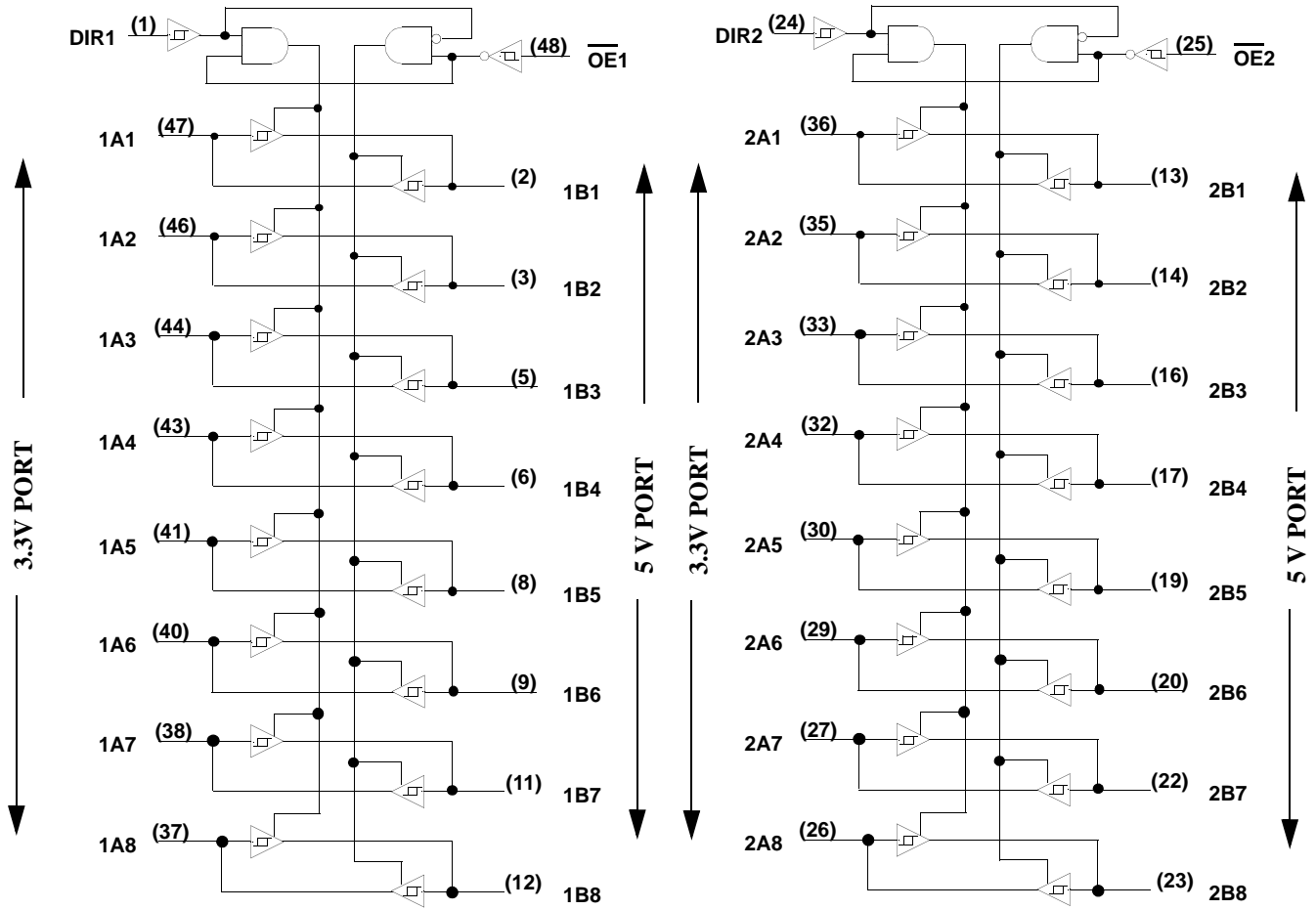

OPERATIONAL ENVIRONMENT¹

PARAMETER	LIMIT	UNITS
Total Dose	1.0E5	rad(Si)
SEL Immune	>114	MeV-cm ² /mg
Neutron Fluence ²	1.0E14	n/cm ²

Notes:

- Logic will not latchup during radiation exposure within the limits defined in the table.
- Not tested, inherent of CMOS technology.

ABSOLUTE MAXIMUM RATINGS¹

SYMBOL	PARAMETER	LIMIT (Mil only)	UNITS
V _{I/O} (Port B) ²	Voltage any pin during operation	-0.3 to V _{DD1} +0.3	V
V _{I/O} (Port A) ²	Voltage any pin during operation	-0.3 to V _{DD1} +0.3	V
V _{DD1}	Supply voltage	-0.3 to 6.0	V
V _{DD2}	Supply voltage	-0.3 to 6.0	V
T _{STG}	Storage Temperature range	-65 to +150	°C
T _J	Maximum junction temperature	+175	°C
θ _{JC}	Thermal resistance junction to case	20	°C/W
I _I	DC input current	±10	mA
P _D	Maximum power dissipation	1	W

Note:

- Stresses outside the listed absolute maximum ratings may cause permanent damage to the device. This is a stress rating only, functional operation of the device at these or any other conditions beyond limits indicated in the operational sections is not recommended. Exposure to absolute maximum rating conditions for extended periods may affect device reliability and performance.
- For cold spare mode (V_{DD} = V_{SS}), V_{I/O} may be -0.3V to the maximum recommended operating V_{DD} + 0.3V.

DUAL SUPPLY OPERATING CONDITIONS

SYMBOL	PARAMETER	LIMIT	UNITS
V _{DD1}	Supply voltage	3.0 to 3.6 or 4.5 to 5.5	V
V _{DD2}	Supply voltage	3.0 to 3.6 or 4.5 to 5.5	V
V _{IN} (Port B)	Input voltage any pin	0 to V _{DD1}	V
V _{IN} (Port A)	Input voltage any pin	0 to V _{DD2}	V
T _C	Temperature range	-55 to +125	°C

DC ELECTRICAL CHARACTERISTICS ¹

(T_c = -55°C to +125°C for "C" screening and -40°C to +125°C for "W" screening)

SYMBOL	PARAMETER	CONDITION	MIN	MAX	UNIT
V _{T+}	Schmitt Trigger, positive going threshold ²	V _{DD} from 3.0 to 5.5		.7V _{DD}	V
V _{T-}	Schmitt Trigger, negative going threshold ²	V _{DD} from 3.0 to 5.5	.3V _{DD}		V
V _{H1}	Schmitt Trigger range of hysteresis	V _{DD} from 4.5 to 5.5	0.6		V
V _{H2}	Schmitt Trigger range of hysteresis	V _{DD} from 3.0 to 3.6	0.4		V
I _{IN}	Input leakage current	V _{DD} from 3.6 to 5.5 V _{IN} = V _{DD} or V _{SS}	-1	3	μA
I _{OZ}	Three-state output leakage current	V _{DD} from 3.6 to 5.5 V _{IN} = V _{DD} or V _{SS}	-1	3	μA
I _{CS}	Cold sparing leakage current ³	V _{IN} = 5.5 V _{DD} = V _{SS}	-1	5	μA
I _{WS}	Warm sparing input leakage current (any pin) ³	V _{IN} = 5.5V V _{DD1} = V _{SS} & V _{DD2} = 3.0V to 5.5V or V _{DD1} = 3.0V to 5.5V & V _{DD2} = V _{SS}	-1	5	μA
I _{OS1}	Short-circuit output current ^{6, 10}	V _O = V _{DD} or V _{SS} V _{DD} from 4.5 to 5.5	-200	200	mA
I _{OS2}	Short-circuit output current ^{6, 10}	V _O = V _{DD} or V _{SS} V _{DD} from 3.0 to 3.6	-100	100	mA
V _{OL1}	Low-level output voltage ⁴	I _{OL} = 8mA I _{OL} = 100μA V _{DD} = 4.5		0.4 0.2	V
V _{OL2}	Low-level output voltage ⁴	I _{OL} = 8mA I _{OL} = 100μA V _{DD} = 3.0		0.5 0.2	V
V _{OH1}	High-level output voltage ⁴	I _{OH} = -8mA I _{OH} = -100μA V _{DD} = 4.5	V _{DD} - 0.7 V _{DD} - 0.2		V
V _{OH2}	High-level output voltage ⁴	I _{OH} = -8mA I _{OH} = -100μA V _{DD} = 3.0	V _{DD} - 0.9 V _{DD} - 0.2		V

P_{total1}	Power dissipation ^{5,7, 8}	$C_L = 50\text{pF}$ V_{DD} from 4.5 to 5.5		2.0	mW/ MHz
P_{total2}	Power dissipation ^{5, 7, 8}	$C_L = 50\text{pF}$ V_{DD} from 3.00 to 3.6		1.5	mW/ MHz
I_{DDQ}	Standby Supply Current V_{DD1} or V_{DD2} Pre-Rad 25°C Pre-Rad -55°C to +125°C Post-Rad 25°C	$V_{IN} = V_{DD}$ or V_{SS} $V_{DD} = 5.5$ $\overline{OE} = V_{DD}$ $\overline{OE} = V_{DD}$ $\overline{OE} = V_{DD}$		60 100 100	μA μA μA
C_{IN}	Input capacitance ⁹	$f = 1\text{MHz @ } 0\text{V}$ V_{DD} from 3.0 to 5.5		15	pF
C_{OUT}	Output capacitance ⁹	$f = 1\text{MHz @ } 0\text{V}$ V_{DD} from 3.0 to 5.5		15	pF

Notes:

- All specifications valid for radiation dose $\leq 1\text{E}5$ rad(Si) per MIL-STD-883, Method 1019.
- Functional tests are conducted in accordance with MIL-STD-883 with the following input test conditions: $V_{IH} = V_{IH(\text{min})} + 20\%$, $- 0\%$; $V_{IL} = V_{IL(\text{max})} + 0\%$, $- 50\%$, as specified herein, for TTL, CMOS, or Schmitt compatible inputs. Devices may be tested using any input voltage within the above specified range, but are guaranteed to $V_{IH(\text{min})}$ and $V_{IL(\text{max})}$.
- This parameter is unaffected by the state of $\overline{OE}x$ or $\text{DIR}x$.
- Per MIL-PRF-38535, for current density $\leq 5.0\text{E}5$ amps/cm², the maximum product of load capacitance (per output buffer) times frequency should not exceed 3,765 pF-MHz.
- Guaranteed by characterization.
- Not more than one output may be shorted at a time for maximum duration of one second.
- Power does not include power contribution of any CMOS output sink current.
- Power dissipation specified per switching output.
- Capacitance measured for initial qualification and when design changes may affect the value. Capacitance is measured between the designated terminal and V_{SS} at frequency of 1MHz and a signal amplitude of 50mV rms maximum.
- Supplied as a design limit, but not guaranteed or tested.

AC ELECTRICAL CHARACTERISTICS*¹ (Port B = 5 Volt, Port A = 3.3 Volt)

(V_{DD1} = 5V ±10%; V_{DD2} = 3.3V ± 0.3V) (T_c = -55°C to +125°C for "C" screening and -40°C to +125°C for "W" screening)

SYMBOL	PARAMETER	MIN	MAX	UNIT
		UT54ACS164245SEI		
t _{PLH}	Propagation delay Data to Bus	3.5	11	ns
t _{PHL}	Propagation delay Data to Bus	3.5	11	ns
t _{PZL}	Output enable time $\overline{OE}x$ to Bus	2.5	16	ns
t _{PZH}	Output enable time $\overline{OE}x$ to Bus	2.5	16	ns
t _{PLZ}	Output disable time $\overline{OE}x$ to Bus high impedance	2.5	16	ns
t _{PHZ}	Output disable time $\overline{OE}x$ to Bus high impedance	2.5	16	ns
t _{PZL} ²	Output enable time DIRx to Bus	1	18	ns
t _{PZH} ²	Output enable time DIRx to Bus	1	18	ns
t _{PLZ} ²	Output disable time DIRx to Bus high impedance	1	20	ns
t _{PHZ} ²	Output disable time DIRx to Bus high impedance	1	20	ns
t _{SKEW} ³	Skew between outputs	-	600	ps
t _{DSKEW} ⁴	Differential skew between outputs	-	1.5	ns

Notes:

* For devices procured with a total ionizing dose tolerance guarantee, the post-irradiation performance is guaranteed at 25°C per MIL-STD-883 Method 1019, Condition A up to the maximum TID level procured.

1. All specifications valid for radiation dose ≤ 1E5 rad(Si) per MIL-STD-883, Method 1019.
2. DIRx to bus times are guaranteed by design, but not tested. $\overline{OE}x$ to bus times are tested
3. Output skew is defined as a comparison of any two output transitions of the same type at the same temperature and voltage for the same port within the same byte: 1A1 through 1A8 are compared high-to-low versus high-to-low and low-to-high versus low-to-high; similarly 1B1 through 1B8 are compared, 2A1 through 2A8 are compared, and 2B1 through 2B8 are compared.
4. Differential output skew is defined as a comparison of any two output transitions of opposite types on the same type at the same temperature and voltage for the same port within the same byte: 1A1 through 1A8 are compared high-to-low versus low-to-high; similarly 1B1 through 1B8 are compared, 2A1 through 2A8 are compared, and 2B1 through 2B8 are compared.

Propagation Delay

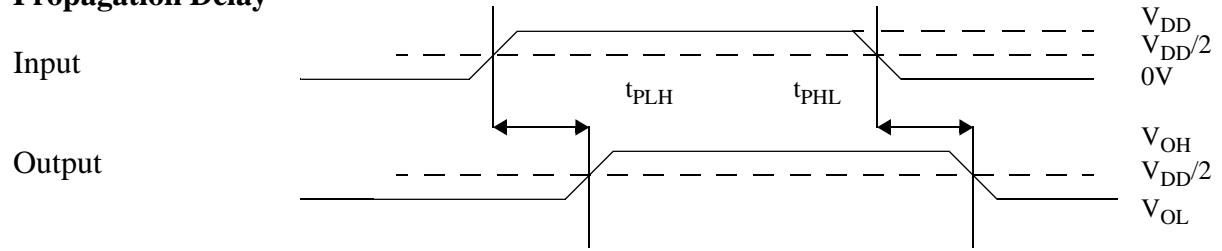

Enable Disable Times

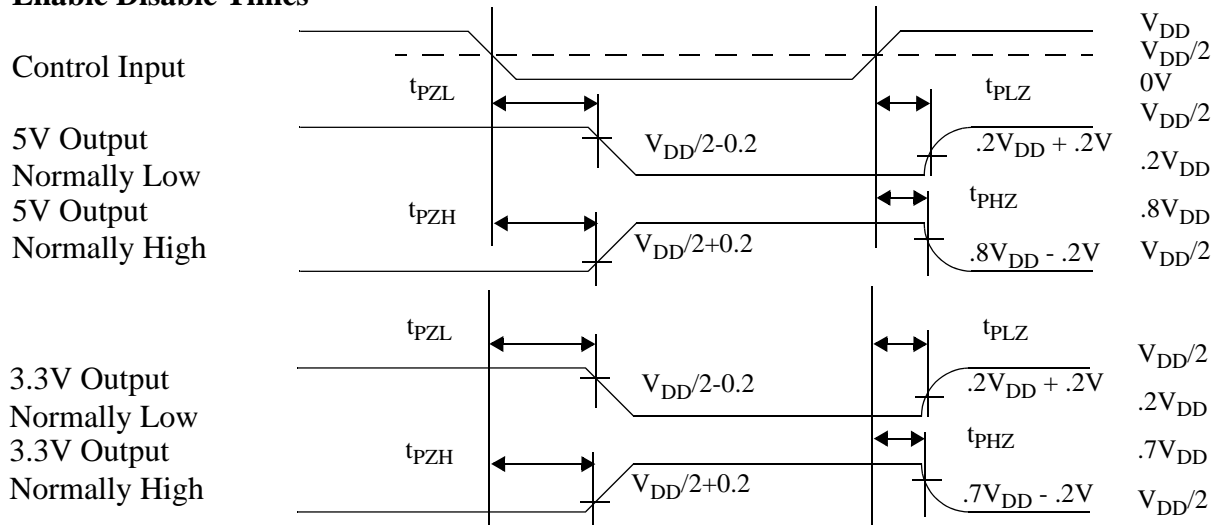

AC ELECTRICAL CHARACTERISTICS*¹ (Port A = Port B, 5 Volt Operation)

(V_{DD1} = 5V ± 10%; V_{DD2} = 5.0V ± 10%) (T_c = -55°C to +125°C for "C" screening and -40°C to +125°C for "W" screening)

SYMBOL	PARAMETER	MIN	MAX	UNIT
		UT54ACS164245SEI		
t _{PLH}	Propagation delay Data to Bus	3.5	9	ns
t _{PHL}	Propagation delay Data to Bus	3.5	9	ns
t _{PZL}	Output enable time $\overline{OE}x$ to Bus	3	9	ns
t _{PZH}	Output enable time $\overline{OE}x$ to Bus	3	9	ns
t _{PLZ}	Output disable time $\overline{OE}x$ to Bus high impedance	3	9	ns
t _{PHZ}	Output disable time $\overline{OE}x$ to Bus high impedance	3	9	ns
t _{PZL} ²	Output enable time DIRx to Bus	1	12	ns
t _{PZH} ²	Output enable time DIRx to Bus	1	12	ns
t _{PLZ} ²	Output disable time DIRx to Bus high impedance	1	15	ns
t _{PHZ} ²	Output disable time DIRx to Bus high impedance	1	15	ns
t _{SKEW} ³	Skew between outputs	-	600	ps
t _{DSKEW} ⁴	Differential skew between outputs	-	1.5	ns

Notes:

* For devices procured with a total ionizing dose tolerance guarantee, the post-irradiation performance is guaranteed at 25°C per MIL-STD-883 Method 1019, Condition A up to the maximum TID level procured.

1. All specifications valid for radiation dose ≤ 1E5 rad(Si) per MIL-STD-883, Method 1019.
2. DIRx to bus times are guaranteed by design, but not tested. $\overline{OE}x$ to bus times are tested
3. Output skew is defined as a comparison of any two output transitions of the same type at the same temperature and voltage for the same port within the same byte: 1A1 through 1A8 are compared high-to-low versus high-to-low and low-to-high versus low-to-high; similarly 1B1 through 1B8 are compared, 2A1 through 2A8 are compared, and 2B1 through 2B8 are compared.
4. Differential output skew is defined as a comparison of any two output transitions of opposite types on the same type at the same temperature and voltage for the same port within the same byte: 1A1 through 1A8 are compared high-to-low versus low-to-high; similarly 1B1 through 1B8 are compared, 2A1 through 2A8 are compared, and 2B1 through 2B8 are compared.

Propagation Delay

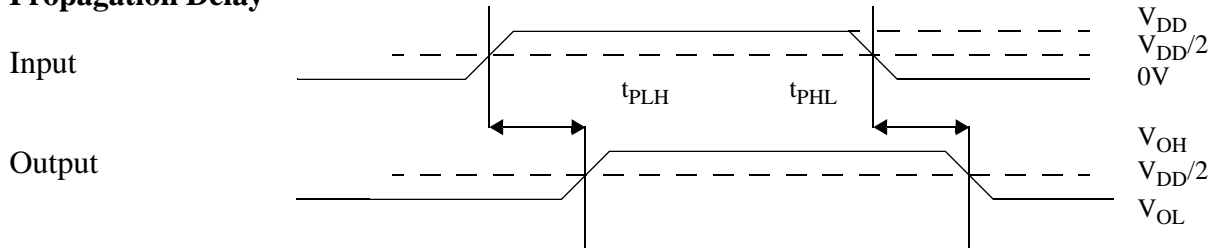

Enable Disable Times

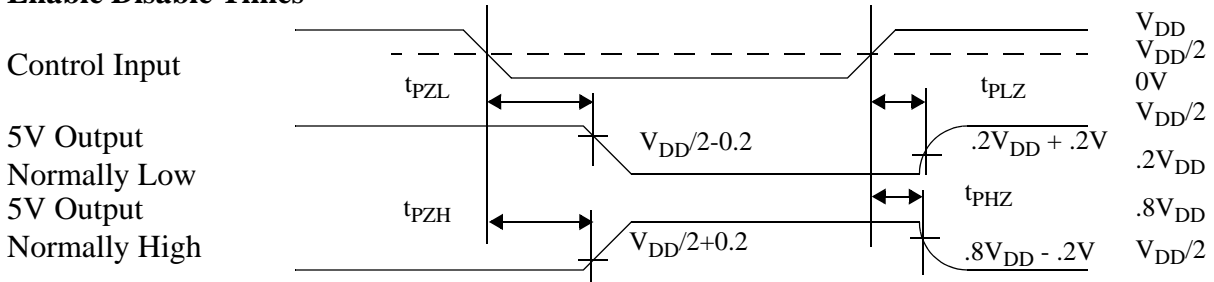

Propagation Delay

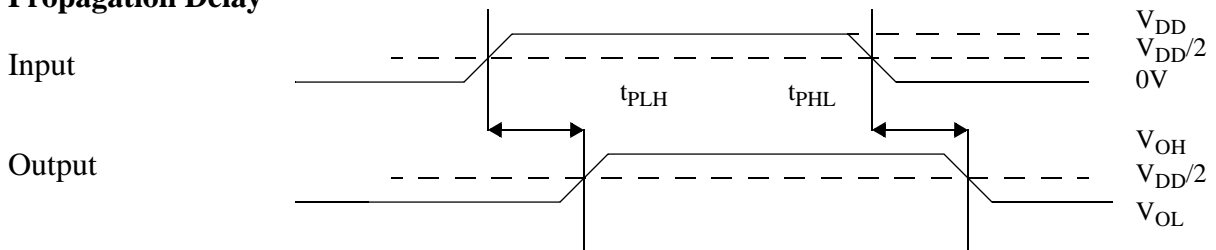

Enable Disable Times

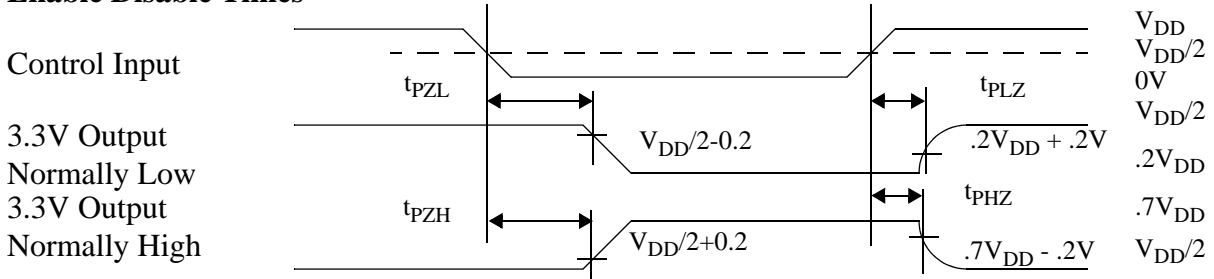

AC ELECTRICAL CHARACTERISTICS*¹ (Port A = Port B, 3.3 Volt Operation)

(V_{DD1} = 3.3V ± 0.3V; V_{DD2} = 3.3V ± 0.3V) (T_c = -55°C to +125°C for "C" screening and -40°C to +125°C for "W" screening)

SYMBOL	PARAMETER	MIN	MAX	UNIT
		UT54ACS164245SEI		
t _{PLH}	Propagation delay Data to Bus	3.5	11	ns
t _{PHL}	Propagation delay Data to Bus	3.5	11	ns
t _{PZL}	Output enable time \overline{OEx} to Bus	2.5	16	ns
t _{PZH}	Output enable time \overline{OEx} to Bus	2.5	16	ns
t _{PLZ}	Output disable time \overline{OEx} to Bus high impedance	2.5	16	ns
t _{PHZ}	Output disable time \overline{OEx} to Bus high impedance	2.5	16	ns
t _{PZL} ²	Output enable time DIRx to Bus	1	18	ns
t _{PZH} ²	Output enable time DIRx to Bus	1	18	ns
t _{PLZ} ²	Output disable time DIRx to Bus high impedance	1	20	ns
t _{PHZ} ²	Output disable time DIRx to Bus high impedance	1	20	ns
t _{SKEW} ³	Skew between outputs		600	ps
t _{DSKEW} ⁴	Differential skew between outputs		1.5	ns

Notes:

* For devices procured with a total ionizing dose tolerance guarantee, the post-irradiation performance is guaranteed at 25°C per MIL-STD-883 Method 1019, Condition A up to the maximum TID level procured.

1. All specifications valid for radiation dose ≤ 1E5 rad(Si) per MIL-STD-883, Method 1019.
2. DIRx to bus times are guaranteed by design, but not tested. \overline{OEx} to bus times are tested.
3. Output skew is defined as a comparison of any two output transitions of the same type at the same temperature and voltage for the same port within the same byte: 1A1 through 1A8 are compared high-to-low versus high-to-low and low-to-high versus low-to-high; similarly 1B1 through 1B8 are compared, 2A1 through 2A8 are compared, and 2B1 through 2B8 are compared.
4. Differential output skew is defined as a comparison of any two output transitions of opposite types on the same type at the same temperature and voltage for the same port within the same byte: 1A1 through 1A8 are compared high-to-low versus low-to-high; similarly 1B1 through 1B8 are compared, 2A1 through 2A8 are compared, and 2B1 through 2B8 are compared.

PACKAGE

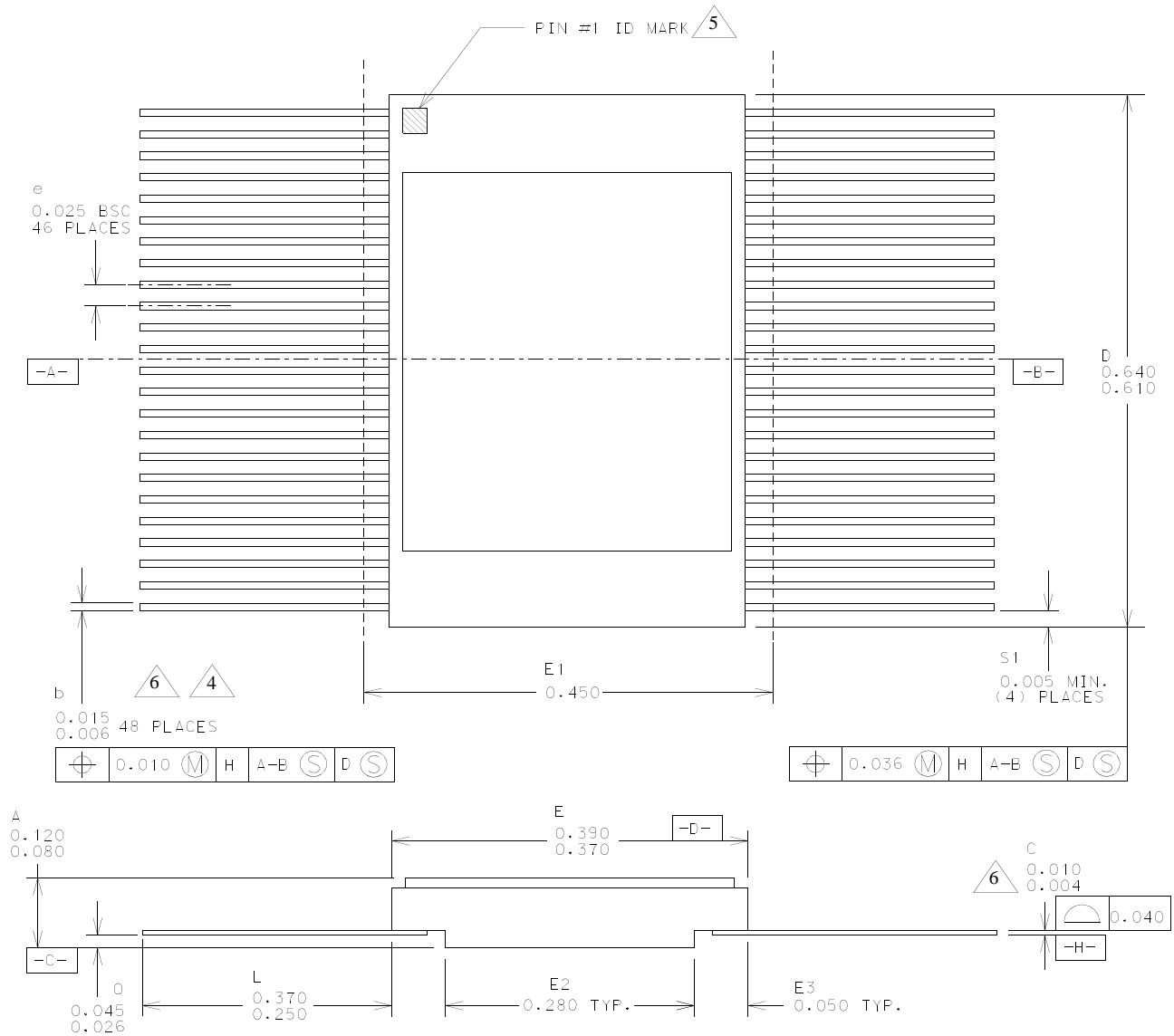

1. All exposed metallized areas are gold plated over electroplated nickel per MIL-PRF-38535.
2. The lid is electrically connected to VSS.
3. Lead finishes are in accordance with MIL-PRF-38535.
4. Lead position and colanarity are not measured.
5. ID mark symbol is vendor option.
6. With solder, increase maximum by 0.003.

Figure 1. 48-Lead Flatpack

ORDERING INFORMATION

UT54ACS164245SEI: SMD

5962 R 98580 ** * * *

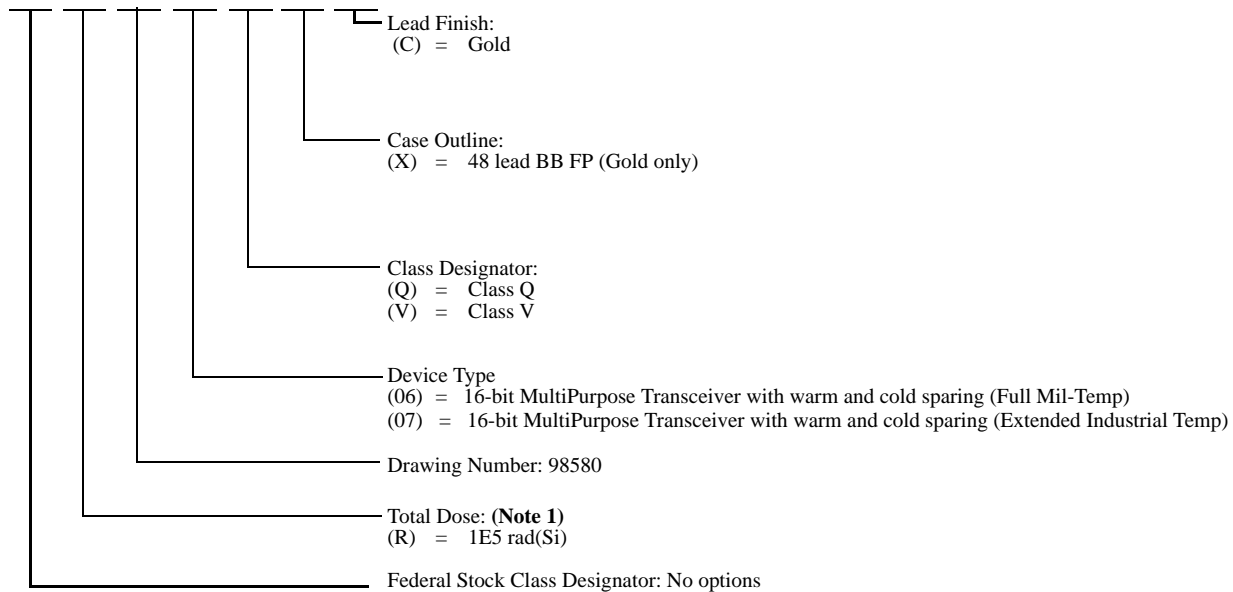

Notes:

1. Total dose radiation must be specified when ordering. QML Q and QML V not available without radiation hardening.

UT54ACS164245SEI

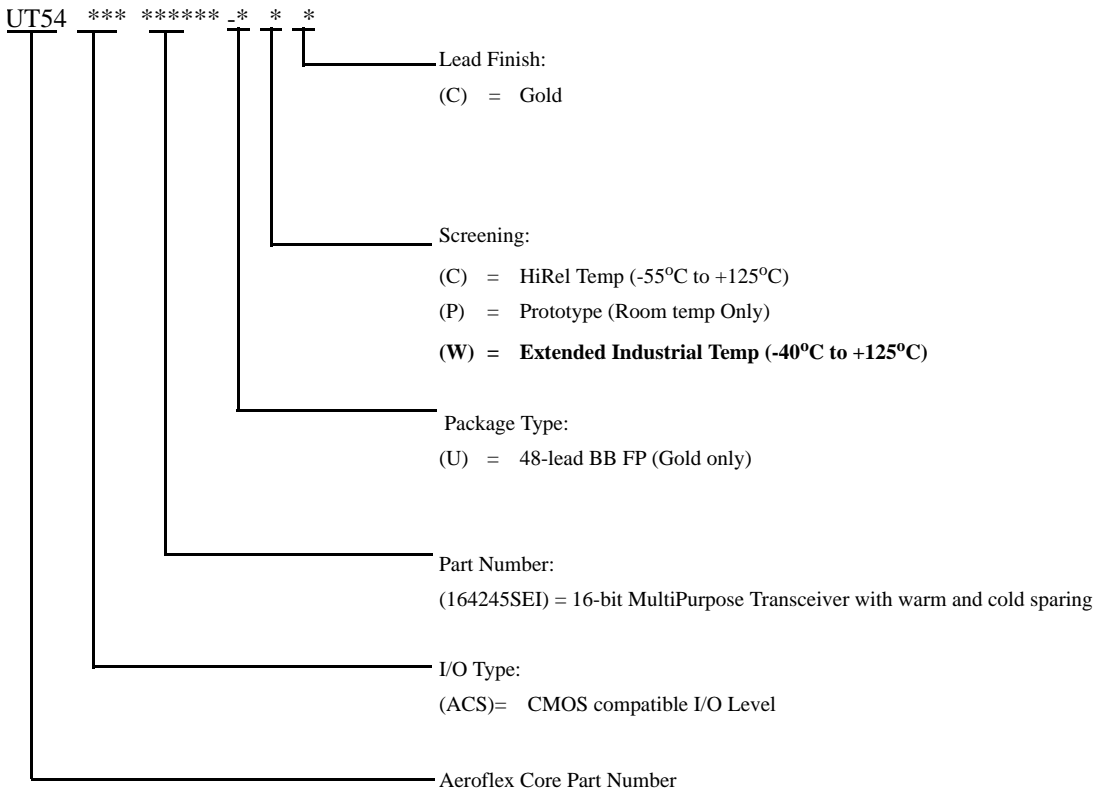

Notes:

1. HiRel Temperature Range flow per Aeroflex Manufacturing Flows Document. Devices are tested -55C, room temp, and 125C. Radiation neither tested nor guaranteed.
2. Extended Industrial Temperature Range Flow per Aeroflex Manufacturing Flows Document. Devices are tested at -40°C, room temp, and +125°C. Radiation is neither tested nor guaranteed.
3. Extended Industrial Range flow per Aeroflex Colorado Springs Manufacturing Flows Document. Devices are tested at -40°C, room temp, and 125°C. Radiation neither tested nor guaranteed.

Aeroflex Colorado Springs - Datasheet Definition

Advanced Datasheet - Product In Development

Preliminary Datasheet - Shipping Prototype

Datasheet - Shipping QML & Reduced Hi-Rel

COLORADO

Toll Free: 800-645-8862
Fax: 719-594-8468

INTERNATIONAL

Tel: 805-778-9229
Fax: 805-778-1980

NORTHEAST

Tel: 603-888-3975
Fax: 603-888-4585

SE AND MID-ATLANTIC

Tel: 321-951-4164
Fax: 321-951-4254

WEST COAST

Tel: 949-362-2260
Fax: 949-362-2266

CENTRAL

Tel: 719-594-8017
Fax: 719-594-8468

www.aeroflex.com info-ams@aeroflex.com

Aeroflex Colorado Springs, Inc. reserves the right to make changes to any products and services herein at any time without notice. Consult Aeroflex or an authorized sales representative to verify that the information in this data sheet is current before using this product. Aeroflex does not assume any responsibility or liability arising out of the application or use of any product or service described herein, except as expressly agreed to in writing by Aeroflex; nor does the purchase, lease, or use of a product or service from Aeroflex convey a license under any patent rights, copyrights, trademark rights, or any other of the intellectual rights of Aeroflex or of third parties.



Our passion for performance is defined by three attributes represented by these three icons: solution-minded, performance-driven and customer-focused