

# UT54ACTS153E

## Dual 4 to 1 Multiplexers

October 2008

www.aeroflex.com/Logic



### FEATURES

- 0.6µm CRH CMOS Process
  - Latchup immune
- High speed
- Low power consumption
- Wide power supply operating range of 3.0V to 5.5V
- Available QML Q or V processes
- 16-lead flatpack

### DESCRIPTION

The UT54ACTS153E is a dual four-to-one line selectors/multiplexer. Common inputs A and B select a value from one of four sources for each section and routes the value from each section to their respective outputs. Separate strobe inputs,  $\overline{G}$  are provided for each of the two four-line sections.

The device is characterized over the full HiRel temperature range of -55°C to +125°C.

### FUNCTION TABLE

SELECT INPUTS		DATA INPUTS				OUTPUT CONTROL	OUTPUT
B	A	C0	C1	C2	C3	$\overline{G}$	Y
X	X	X	X	X	X	H	L
L	L	L	X	X	X	L	L
L	L	H	X	X	X	L	H
L	H	X	L	X	X	L	L
L	H	X	H	X	X	L	H
H	L	X	X	L	X	L	L
H	L	X	X	H	X	L	H
H	H	X	X	X	L	L	L
H	H	X	X	X	H	L	H

### PINOUT

16-Lead Flatpack  
Top View

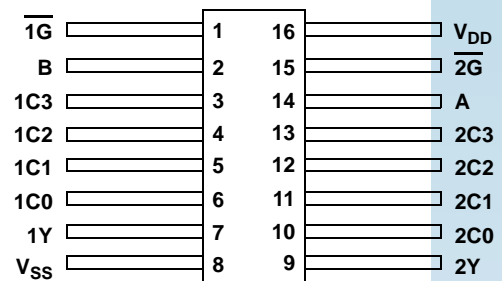

### LOGIC SYMBOL

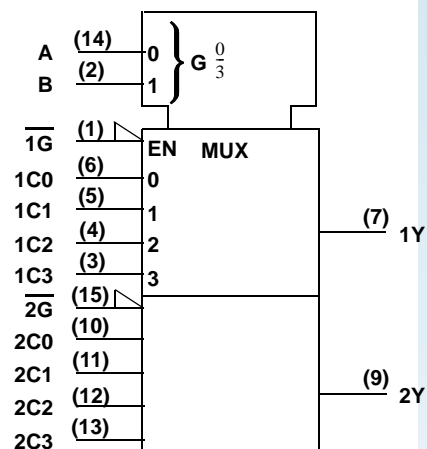

**Note:**

1. Logic symbol in accordance with ANSI/IEEE Std 91-1984 and IEC Publication 617-12.

**LOGIC DIAGRAM**

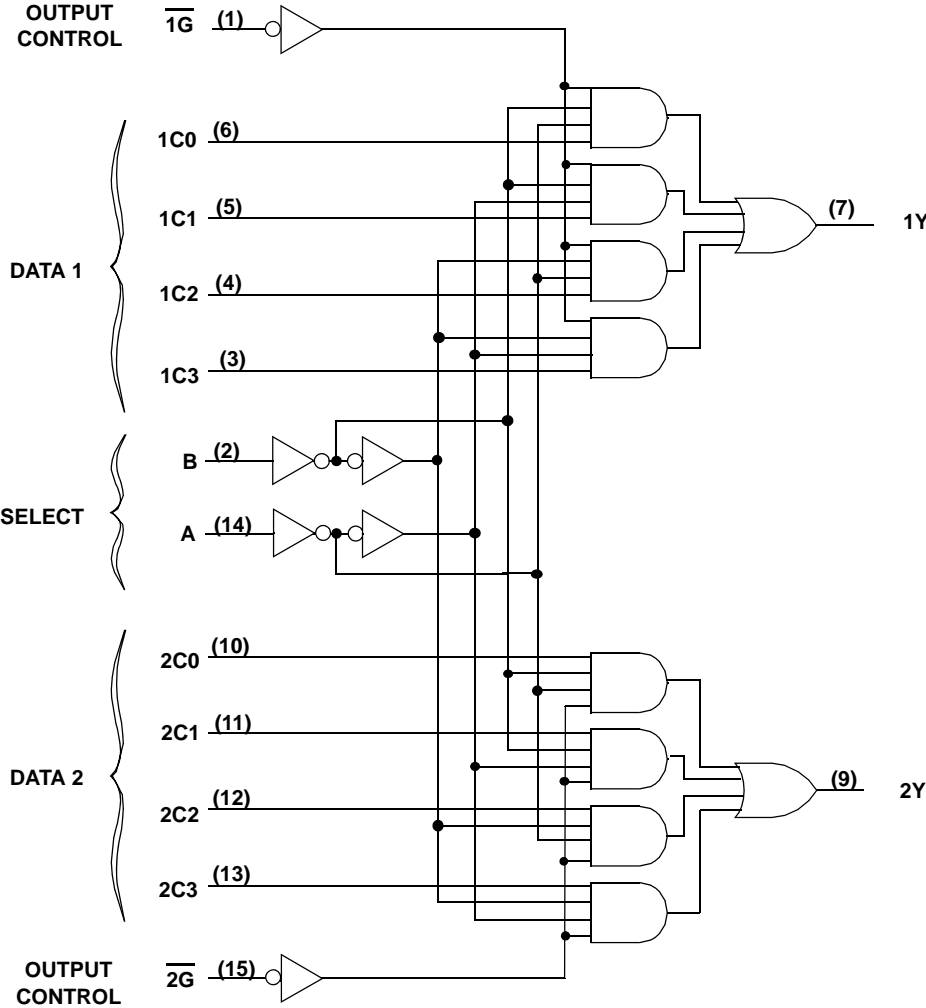

## OPERATIONAL ENVIRONMENT<sup>1</sup>

PARAMETER	LIMIT	UNITS
Total Dose	1.0E6	rads(Si)
SEU Threshold <sup>2</sup>	80	MeV-cm <sup>2</sup> /mg
SEL Threshold	120	MeV-cm <sup>2</sup> /mg
Neutron Fluence	1.0E14	n/cm <sup>2</sup>

**Notes:**

1. Logic will not latchup during radiation exposure within the limits defined in the table.
2. Device storage elements are immune to SEU affects.

## ABSOLUTE MAXIMUM RATINGS<sup>1</sup>

SYMBOL	PARAMETER	LIMIT	UNITS
V <sub>DD</sub>	Supply voltage	-0.3 to 7.0	V
V <sub>I/O</sub>	Voltage any pin	-.3 to V <sub>DD</sub> +.3	V
T <sub>STG</sub>	Storage Temperature range	-65 to +150	°C
T <sub>J</sub>	Maximum junction temperature	+175	°C
T <sub>LS</sub>	Lead temperature (soldering 5 seconds)	+300	°C
Θ <sub>JC</sub>	Thermal resistance junction to case	20	°C/W
I <sub>I</sub>	DC input current	±10	mA
P <sub>D</sub>	Maximum power dissipation	1	W

**Note:**

1. Stresses outside the listed absolute maximum ratings may cause permanent damage to the device. This is a stress rating only, functional operation of the device at these or any other conditions beyond limits indicated in the operational sections is not recommended. Exposure to absolute maximum rating conditions for extended periods may affect device reliability.

## RECOMMENDED OPERATING CONDITIONS

SYMBOL	PARAMETER	LIMIT	UNITS
V <sub>DD</sub>	Supply voltage	3.0 to 5.5	V
V <sub>IN</sub>	Input voltage any pin	0 to V <sub>DD</sub>	V
T <sub>C</sub>	Temperature range	-55 to +125	°C

## DC ELECTRICAL CHARACTERISTICS FOR THE UT54ACTS153E<sup>7</sup>

( $V_{DD} = 3.0V$  to  $5.5V$ ;  $V_{SS} = 0V$ <sup>6</sup>;  $-55^{\circ}C < T_C < +125^{\circ}C$ )

SYMBOL	Description	CONDITION	VDD	MIN	MAX	UNIT
$V_{IL}$	Low-level input voltage <sup>1</sup>		3.0V		0.8	V
			5.5V		0.8	
$V_{IH}$	High-level input voltage <sup>1</sup>		3.0V	2.0		V
			5.5V	2.75		
$I_{IN}$	Input leakage current	$V_{IN} = V_{DD}$ or $V_{SS}$	5.5V	-1	1	$\mu A$
$V_{OL}$	Low-level output voltage <sup>3</sup>	$I_{OL} = 6mA$	3.0V		0.4	V
		$I_{OL} = 8mA$	4.5V		0.4	V
$V_{OH}$	High-level output voltage <sup>3</sup>	$I_{OH} = -6mA$	3.0V	2.4		V
		$I_{OH} = -8mA$	4.5V	3.15		V
$I_{OS}$	Short-circuit output current <sup>2,4</sup>	$V_O = V_{DD}$ and $V_{SS}$	3.0V	-100	100	mA
			5.5V	-200	200	
$I_{OL}$	Low level output current <sup>10</sup>	$V_{IN} = V_{DD}$ or $V_{SS}$ $V_{OL} = 0.4V$	3.0V	6		mA
			5.5V	8		
$I_{OH}$	High level output current <sup>10</sup>	$V_{IN} = V_{DD}$ or $V_{SS}$ $V_{OH} = V_{DD} - 0.4V$	3.0V		-6	mA
			5.5V		-8	
$P_{total}$	Power dissipation <sup>2, 8, 9</sup>	$C_L = 50pF$	5.5V		2.1	mW/ MHz
			3.0V		0.84	
$I_{DDQ}$	Quiescent Supply Current	$V_{IN} = V_{DD}$ or $V_{SS}$	5.5V		10	$\mu A$
$\Delta I_{DDQ}$	Quiescent Supply Current Delta	For input under test $V_{IN} = V_{DD} - 2.1V$ For all other inputs $V_{IN} = V_{DD}$ or $V_{SS}$	5.5V		1.6	mA
$C_{IN}$	Input capacitance <sup>5</sup>	$f = 1MHz$	0V		15	pF
$C_{OUT}$	Output capacitance <sup>5</sup>	$f = 1MHz$	0V		15	pF

### Notes:

- Functional tests are conducted in accordance with MIL-STD-883 with the following input test conditions:  $V_{IH} = V_{IH}(\min) + 20\%$ ,  $-0\%$ ;  $V_{IL} = V_{IL}(\max) + 0\%$ ,  $-50\%$ , as specified herein, for TTL, CMOS, or Schmitt compatible inputs. Devices may be tested using any input voltage within the above specified range, but are guaranteed to  $V_{IH}(\min)$  and  $V_{IL}(\max)$ .
- Supplied as a design limit but not guaranteed or tested.
- Per MIL-PRF-38535, for current density  $\leq 5.0E5$  amps/cm<sup>2</sup>, the maximum product of load capacitance (per output buffer) times frequency should not exceed 3,765pF/MHz.
- Not more than one output may be shorted at a time for maximum duration of one second.
- Capacitance measured for initial qualification and when design changes may affect the value. Capacitance is measured between the designated terminal and  $V_{SS}$  at frequency of 1MHz and a signal amplitude of 50mV rms maximum.
- Maximum allowable relative shift equals 50mV.
- All specifications valid for radiation dose  $\leq 1E6$  rads(Si) per MIL-STD-883 Method 1019 Condition A and section 3.11.2.
- Power does not include power contribution of any TTL output sink current
- Power dissipation specified per switching output.
- This value is guaranteed based on characterization data, but not tested.

## AC ELECTRICAL CHARACTERISTICS FOR THE UT54ACTS153E<sup>2</sup>

( $V_{DD} = 3.0V$  to  $5.5V$ ;  $V_{SS} = 0V$ <sup>1</sup>,  $-55^{\circ}C < T_C < +125^{\circ}C$ )

SYMBOL	PARAMETER	CONDITION	$V_{DD}$	MINIMUM	MAXIMUM	UNIT
$t_{PLH1}$	Data to output Yn	$C_L = 30pF$	3.0V & 3.6V	2	12	ns
			4.5V & 5.5V	2	8	
		$C_L = 50pF$	3.0V & 3.6V	2	16	ns
			4.5V & 5.5V	2	12	
$t_{PHL1}$	Data to output Yn	$C_L = 30pF$	3.0V & 3.6V	1	16	ns
			4.5V & 5.5V	1	12	
		$C_L = 50pF$	3.0V & 3.6V	1	20	ns
			4.5V & 5.5V	1	16	
$t_{PLH2}$	Strobe to output Yn	$C_L = 30pF$	3.0V & 3.6V	1	14	ns
			4.5V & 5.5V	1	10	
		$C_L = 50pF$	3.0V & 3.6V	1	18	ns
			4.5V & 5.5V	1	14	
$t_{PHL2}$	Strobe to output Yn	$C_L = 30pF$	3.0V & 3.6V	1	15	ns
			4.5V & 5.5V	1	11	
		$C_L = 50pF$	3.0V & 3.6V	1	19	ns
			4.5V & 5.5V	1	11	
$t_{PLH3}$	Select to output Yn	$C_L = 30pF$	3.0V & 3.6V	2	14	ns
			4.5V & 5.5V	2	10	
		$C_L = 50pF$	3.0V & 3.6V	2	18	ns
			4.5V & 5.5V	2	14	
$t_{PHL3}$	Select to output Yn	$C_L = 30pF$	3.0V & 3.6V	2	16	ns
			4.5V & 5.5V	2	12	
		$C_L = 50pF$	3.0V & 3.6V	2	20	ns
			4.5V & 5.5V	2	16	

### Notes:

1. Maximum allowable relative shift equals 50mV.
2. All specifications valid for radiation dose  $\leq 1E6$  rads(Si) per MIL-STD-883 Method 1019 Condition A and section 3.11.2.

Packaging

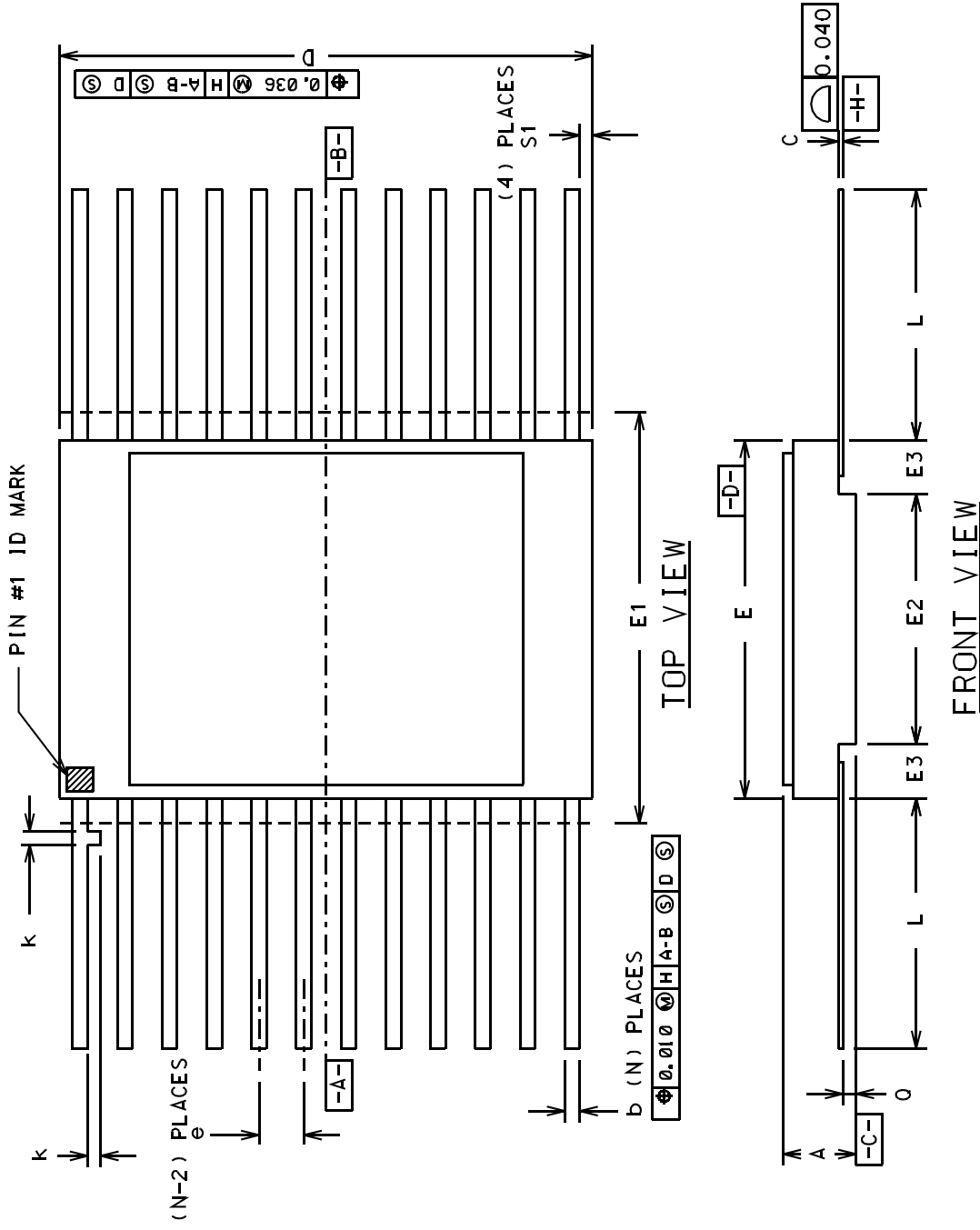

PKG CONFIG	LEAD COUNT	ML-STD 1835 DWG CONF B	DIMENSION SYMBOLS												
			A	b	c	D	E	E1	E2	E3	e	k	L	0	S1
-03	14	F-2A	0.115	0.022	0.009	0.390	0.260	0.290	-----	-----	0.050	0.015	0.370	0.045	-----
			0.045	0.015	0.004	-----	0.235	-----	0.130	0.030	BSC	0.008	0.270	0.026	0.005
-04	16	F-5A	0.115	0.022	0.009	0.440	0.285	0.315	-----	-----	0.050	0.015	0.370	0.045	-----
			0.045	0.015	0.004	-----	0.245	-----	0.130	0.030	BSC	0.008	0.250	0.026	0.005
-05	20	F-9A	0.115	0.022	0.009	0.540	0.300	0.330	-----	-----	0.050	0.015	0.370	0.045	-----
			0.045	0.015	0.004	-----	0.245	-----	0.130	0.030	BSC	0.008	0.250	0.026	0.000

**Ordering Information: UT54ACTS153E: SMD**

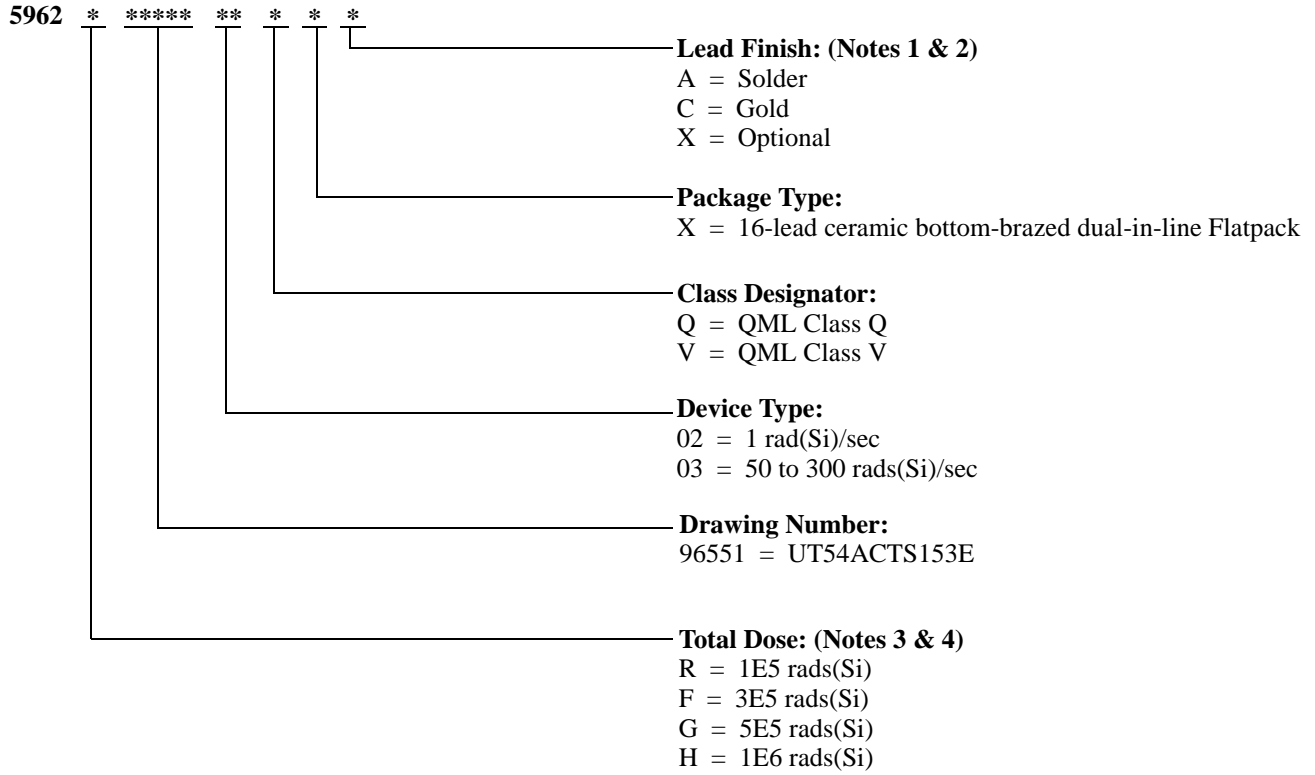

Notes:

1. Lead finish (A,C, or X) must be specified.
2. If an "X" is specified when ordering, part marking will match the lead finish and will be either "A" (solder) or "C" (gold).
3. Total dose radiation must be specified when ordering. QML Q and QML V not available without radiation hardening. For prototype inquiries, contact factory.
4. Device type 02 is only offered with a TID tolerance guarantee of 3E5 rads(Si) or 1E6 rads(Si) and is tested in accordance with MIL-STD-883 Test Method 1019 Condition A and section 3.11.2. Device type 03 is only offered with a TID tolerance guarantee of 1E5 rads(Si), 3E5 rads(Si), and 5E5 rads(Si), and is tested in accordance with MIL-STD-883 Test Method 1019 Condition A.

**COLORADO**

Toll Free: 800-645-8862  
 Fax: 719-594-8468

**INTERNATIONAL**

Tel: 805-778-9229  
 Fax: 805-778-1980

**NORTHEAST**

Tel: 603-888-3975  
 Fax: 603-888-4585

**SE AND MID-ATLANTIC**

Tel: 321-951-4164  
 Fax: 321-951-4254

**WEST COAST**

Tel: 949-362-2260  
 Fax: 949-362-2266

**CENTRAL**

Tel: 719-594-8017  
 Fax: 719-594-8468

[www.aeroflex.com](http://www.aeroflex.com)     [info-ams@aeroflex.com](mailto:info-ams@aeroflex.com)

Aeroflex Colorado Springs (Aeroflex) reserves the right to make changes to any products and services herein at any time without notice. Consult Aeroflex or an authorized sales representative to verify that the information in this data sheet is current before using this product. Aeroflex does not assume any responsibility or liability arising out of the application or use of any product or service described herein, except as expressly agreed to in writing by Aeroflex; nor does the purchase, lease, or use of a product or service from Aeroflex convey a license under any patent rights, copyrights, trademark rights, or any other of the intellectual rights of Aeroflex or of third parties.



Our passion for performance is defined by three attributes represented by these three icons: solution-minded, performance-driven and customer-focused