



UT6354-H

Power MOSFET

-5.0A, -60V P-CHANNEL SILICON MOSFET

DESCRIPTION

The UTC **UT6354-H** is a P-Channel Silicon MOSFET, it uses UTC's advanced technology to provide the customers with a minimum on state resistance and low gate charge, etc.

The UTC **UT6354-H** is suitable for general-purpose switching device applications.

FEATURES

- * $R_{DS(ON)} \leq 100 \text{ m}\Omega$ @ $V_{GS}=-10\text{V}$, $I_D=-2.0\text{A}$
- $R_{DS(ON)} \leq 135 \text{ m}\Omega$ @ $V_{GS}=-4.5\text{V}$, $I_D=-1.0\text{A}$
- $R_{DS(ON)} \leq 145 \text{ m}\Omega$ @ $V_{GS}=-4.0\text{V}$, $I_D=-1.0\text{A}$
- * Low gate charge

SYMBOL

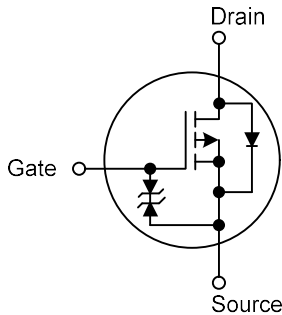

ORDERING INFORMATION

Ordering Number		Package	Pin Assignment						Packing
Lead Free	Halogen Free		1	2	3	4	5	6	
UT6354L-AA3-R	UT6354G-AA3-R	SOT-223	G	D	S	-	-	-	Tape Reel
UT6354L-AE3-R	UT6354G-AE3-R	SOT-23	G	S	D	-	-	-	Tape Reel
UT6354L-AG6-R	UT6354G-AG6-R	SOT-26	D	D	G	S	D	D	Tape Reel

Note: Pin Assignment: G: Gate D: Drain S: Source

UT6354G-AA3-R (1)Packing Type (2)Package Type (3)Green Package	(1) R: Tape Reel (2) AA3: SOT-223, AE3: SOT-23, AG6: SOT-26 (3) G: Halogen Free and Lead Free, L: Lead Free
---	---

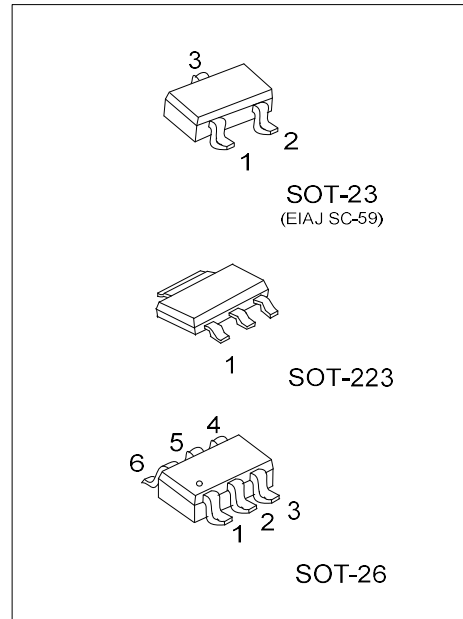

■ MARKING

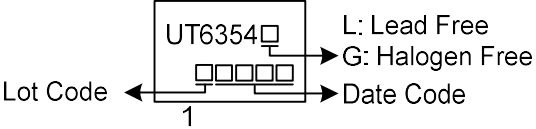
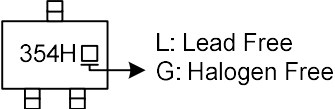
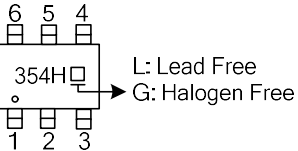
PACKAGE	MARKING
SOT-223	 <p>UT6354 □ □ □ □ □ □ Lot Code ← 1 → Date Code</p> <p>L: Lead Free G: Halogen Free</p>
SOT-23	 <p>□ 354H □ □ □</p> <p>L: Lead Free G: Halogen Free</p>
SOT-26	 <p>6 5 4 □ □ □ 354H □ □ □ □ 1 2 3</p> <p>L: Lead Free G: Halogen Free</p>

■ ABSOLUTE MAXIMUM RATINGS (T_A = 25°C, unless otherwise specified)

PARAMETER		SYMBOL	RATINGS	UNIT
Drain-Source Voltage		V _{DSS}	-60	V
Gate-Source Voltage		V _{GSS}	±20	V
Drain Current	Continuous	I _D	-5	A
	Pulsed (Note 2)	I _{DM}	-16	A
Avalanche Energy	Single Pulsed (Note 3)	E _{AS}	16	mJ
Power Dissipation	SOT-223	P _D	1.5	W
	SOT-23/ SOT-26		1	W
Junction Temperature		T _J	+150	°C
Storage Temperature		T _{STG}	-55 ~ +150	°C

- Notes: 1. Absolute maximum ratings are those values beyond which the device could be permanently damaged. Absolute maximum ratings are stress ratings only and functional device operation is not implied.
 2. Repetitive Rating: Pulse width limited by maximum junction temperature.
 3. L = 0.1mH, I_{AS} = -18.3A, V_{DD} = -50V, R_G = 25 Ω Starting T_J = 25°C

■ THERMAL DATA

PARAMETER		SYMBOL	RATINGS	UNIT
Junction to Ambient	SOT-223	θ _{JA}	83	°C/W
	SOT-23/ SOT-26		125	°C/W

Note: Device mounted on FR-4 substrate PC board, 2oz copper, with 1inch square copper plate.

■ ELECTRICAL CHARACTERISTICS (T_A=25°C unless otherwise specified)

PARAMETER	SYMBOL	TEST CONDITIONS	MIN	TYP	MAX	UNIT
OFF CHARACTERISTICS						
Drain-Source Breakdown Voltage	BV _{DSS}	I _D =-1mA, V _{GS} =0V	-60			V
Zero Gate Voltage Drain Current	I _{DSS}	V _{DS} =-60V, V _{GS} =0V			-1	μA
Gate-to-Source Leakage Current	I _{GSS}	V _{GS} =±16V, V _{DS} =0V			±10	μA
ON CHARACTERISTICS						
Cutoff Voltage	V _{GS(OFF)}	V _{DS} =-10V, I _D =-1mA	-1.0		-2.6	V
Static Drain-Source On-State Resistance	R _{DS(ON)}	V _{GS} =-10V, I _D =-2.0A		77	100	mΩ
		V _{GS} =-4.5V, I _D =-1.0A		96	135	mΩ
		V _{GS} =-4.0V, I _D =-1.0A		103	145	mΩ
DYNAMIC PARAMETERS						
Input Capacitance	C _{ISS}	V _{DS} =-20V, f=1.0MHz		800		pF
Output Capacitance	C _{OSS}			75		pF
Reverse Transfer Capacitance	C _{RSS}			58		pF
SWITCHING PARAMETERS						
Total Gate Charge	Q _G	V _{DS} =-48V, V _{GS} =-10V, I _D =-4A I _G =-1mA		20		nC
Gate to Source Charge	Q _{GS}			5		nC
Gate to Drain Charge	Q _{GD}			4		nC
Turn-ON Delay Time	t _{D(ON)}	V _{DS} =-30V, V _{GS} =-10V, I _D =-4A R _G =3Ω		6		ns
Rise Time	t _R			16		ns
Turn-OFF Delay Time	t _{D(OFF)}			26		ns
Fall-Time	t _F			18		ns
SOURCE- DRAIN DIODE RATINGS AND CHARACTERISTICS						
Diode Forward Voltage	V _{SD}	I _S =-4A, V _{GS} =0V		-0.84	-1.2	V

■ TEST CIRCUITS AND WAVEFORMS

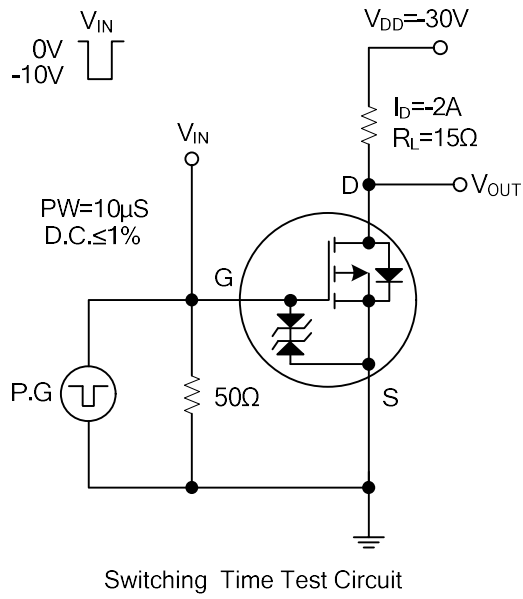

TYPICAL CHARACTERISTICS

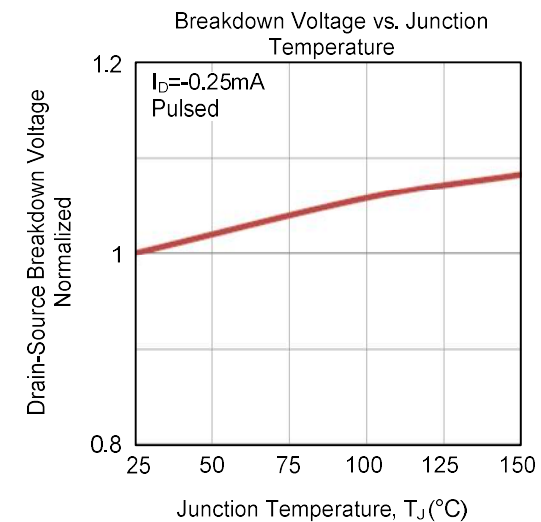
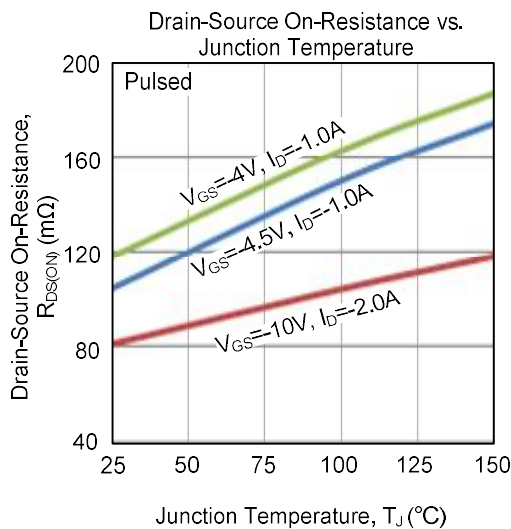
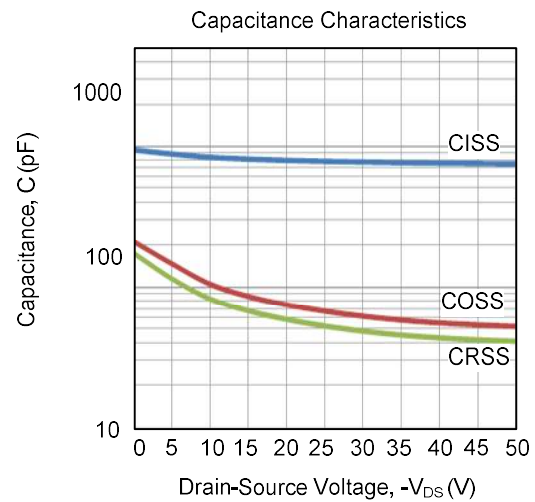
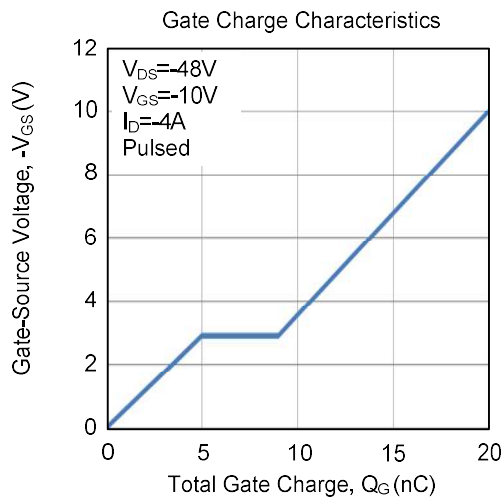
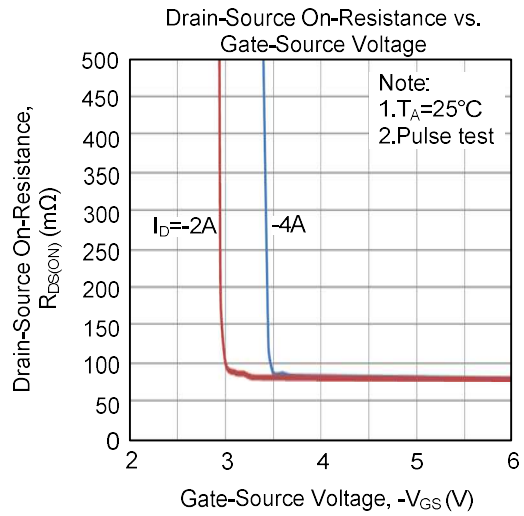
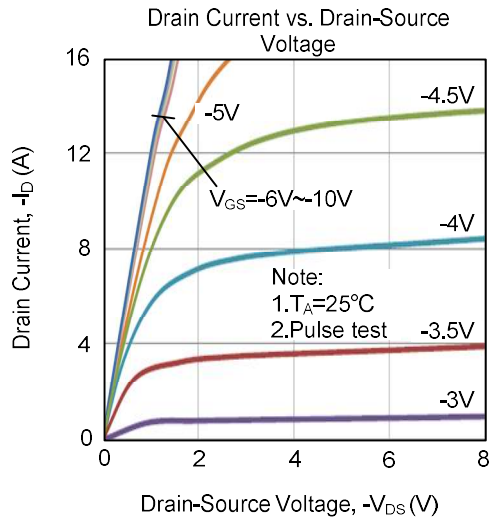

■ TYPICAL CHARACTERISTICS (Cont.)

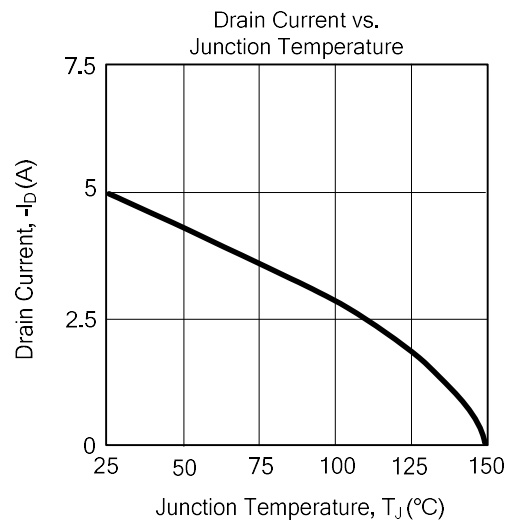
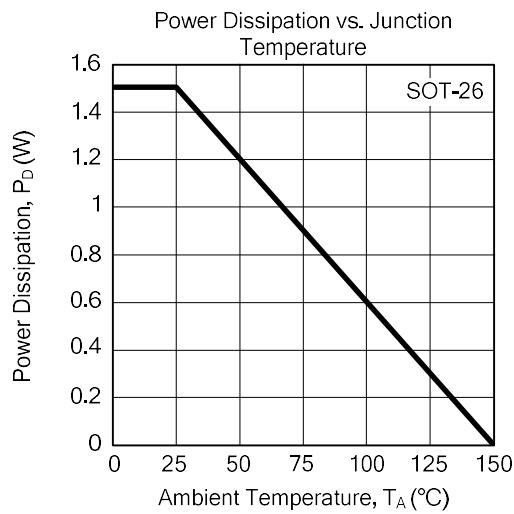
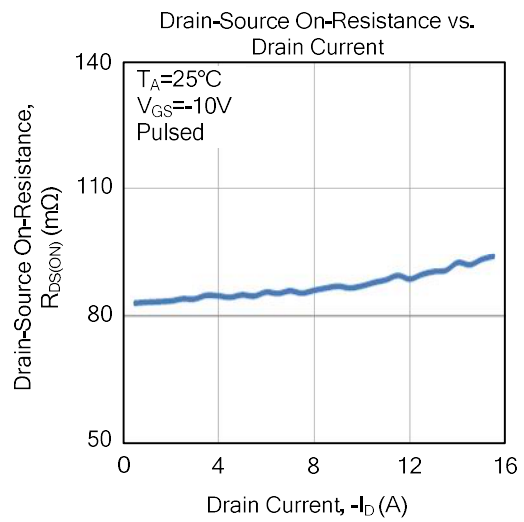
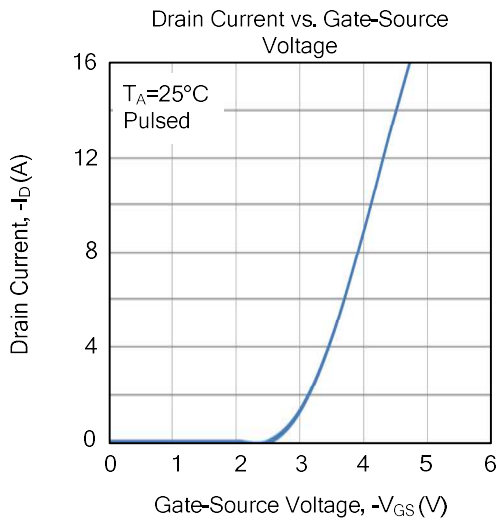
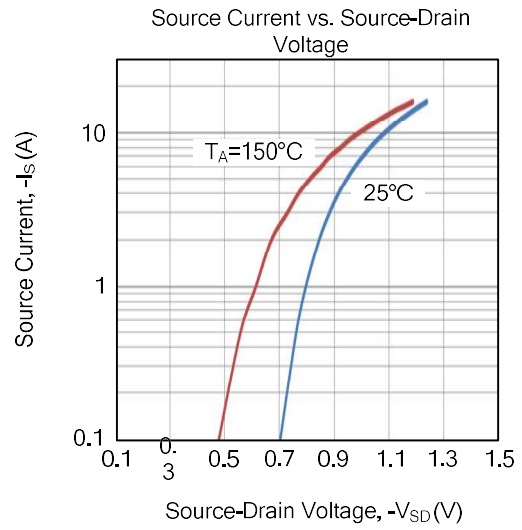
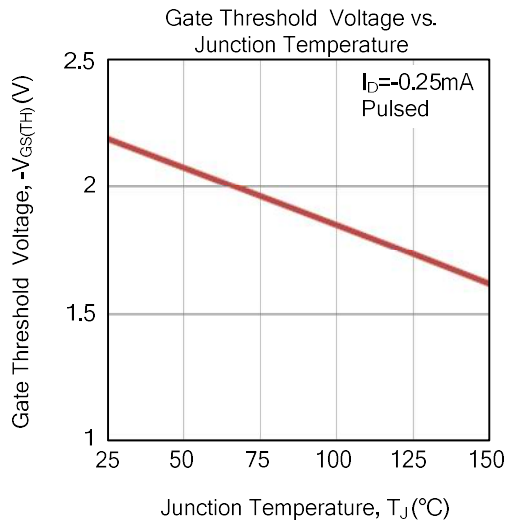

■ TYPICAL CHARACTERISTICS (Cont.)

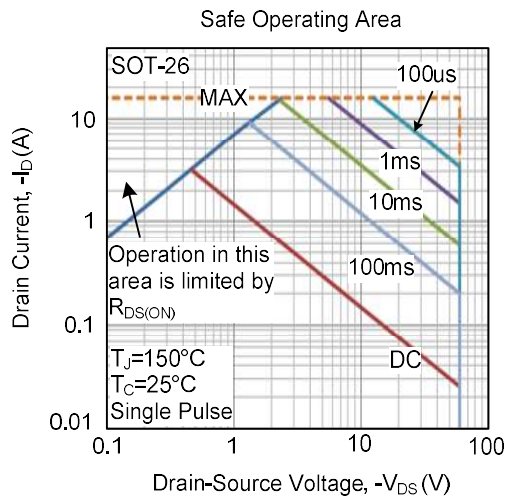

UTC assumes no responsibility for equipment failures that result from using products at values that exceed, even momentarily, rated values (such as maximum ratings, operating condition ranges, or other parameters) listed in products specifications of any and all UTC products described or contained herein. UTC products are not designed for use in life support appliances, devices or systems where malfunction of these products can be reasonably expected to result in personal injury. Reproduction in whole or in part is prohibited without the prior written consent of the copyright owner. UTC reserves the right to make changes to information published in this document, including without limitation specifications and product descriptions, at any time and without notice. This document supersedes and replaces all information supplied prior to the publication hereof.