

1.0 INTRODUCTION

The monolithic μ MMIT provides the system designer with an intelligent solution to MIL-STD-1553 multiplexed serial data bus design problems. The μ MMIT is a single-chip device that implements all three of the defined MIL-STD-1553 functions - Remote Terminal, Bus Controller, and Monitor. Operating either autonomously or with a tightly coupled host, the μ MMIT will solve a wide range of MIL-STD-1553 interface problems. A powerful RISC processing unit provides automatic message handling, message status, general status, and interrupt information. The register-based interface architecture provides many programmable functions as well as extensive information pertinent to device maintenance. In either of the three operating modes, the μ MMIT can access up to 64K x 16 of external memory (65,536 x 16).

The μ MMIT (which derives its name from serial, μ -coded, monolithic, multi-mode, intelligent, terminal) is a powerful asset to a system designer solving the MIL-STD-1553 problem.

1.1 Remote Terminal Features

The μ MMIT Remote Terminal (SRT) conforms to the requirements of MIL-STD-1553B, Notice II. In addition to meeting the requirements of the standard, the SRT has an extensive list of flexible features to meet any MIL-STD-1553 interface requirement.

1.1.1 Indexing

The SRT can buffer up to 256 receive messages on a subaddress-by-subaddress basis. Upon reception of the specified number of messages, the SRT can generate an interrupt by signaling either the host or subsystem that data is ready for processing. The indexing feature is commonly used to implement bulk data transfer algorithms.

1.1.2 Buffer Ping-Pong

To support the transfer of periodic data, double buffering schemes are often incorporated into remote terminal designs. Periodic data transfer incorporates the use of two data buffers per subaddress. The remote terminal processes messages (receive or transmit) via the designated primary buffer. The host or subsystem uses the secondary buffer to collect new data for transmission or process data received during the defined time interval. Upon completion of the defined interval, the remote terminal will switch the primary and secondary data buffers (i.e., ping-pong). The SRT supports ping-pong buffering via a user-selected ping-pong architecture consisting of dual subaddress data pointers.

1.1.3 Circular Buffers

μ MMIT circular buffer modes simplify the software service of remote terminals implementing bulk or periodic data transfers. The μ MMIT architecture allows the user to select one of two circular buffer modes. The user selects the preferred mode, at start-up, by writing to Control Register bits.

1.1.4 Internal Illegalization

An internal 256-bit (16 x 16) RAM allows for the illegalization of all mode codes and subaddresses. The illegalization RAM is accessed at the beginning of message processing to determine if the valid command is prohibited. To eliminate host or subsystem overhead, the μ MMIT can initialize the 256-bit illegalization RAM during the auto-initialization sequence.

1.1.5 Broadcast

Designed to meet the requirements of MIL-STD-1553B Notice II, the SRT can store all data associated with a broadcast command in separate memory from non-broadcast commands. This feature is user-selected via the Descriptor Control word and internal Control Register.

1.1.6 Interrupt History

A programmable interrupt structure allows the host or subsystem the flexibility to enter 16 interrupts into a 32-word buffer before service. This feature allows the logging of multiple interrupts if immediate service is restricted. The interrupt structure enters an Interrupt Information Word (IIW) and an Interrupt Address Word (IAW) indicating what subaddress or command block generated the interrupt. All modes of operation support interrupt logging.

1.1.7 Message Information

The SRT generates a Message Information Word and time-tag (16-bit) for all transacted messages. This information is written into memory along with message data words. The Message Information Word contains word count, message errors, and message type information.

1.2 Bus Controller Features

The μ MMIT Bus Controller (SBC) is a powerful MIL-STD-1553 bus controller developed to meet the requirements of multi-frame processing with low host overhead. User-defined decision making allows the SBC to operate autonomously from the host until a designated event or series of events has taken place.

1.2.1 Multiple Message Processing

The SBC architecture allows the chaining of multiple MIL-STD-1553 commands into major and minor frames depending on the application. This feature allows the host to structure message frames that perform independent tasks such as periodic data transfer, service requests, and bus diagnostics (initiate BIT). The SBC uses a simple opcode scheme to control the command block flow.

1.2.2 Message Scheduling

The SBC allows host entry of data to control the time between messages. This feature is useful when the BC has to perform periodic message transactions with multiple remote terminals.

1.2.3 Polling

The host instructs the SBC to interrogate the status word response of remote terminals to determine if any SBC action is required. The SBC can detect the assertion of status word bits and generate interrupts or branch to a new message frame. Polling is useful if the application requires control of message frame flow as a function of remote terminal response.

1.2.4 Automatic Retry

The SBC can automatically retry a message on busy, message error, or other status word bit response. If enabled, the SBC can retry up to four times on the primary bus or alternate bus.

1.3 Monitor Terminal Features

The μ MMIT Monitor Terminal (SMT) is a full-featured MIL-STD-1553B bus monitor designed to monitor all or selected remote terminals on the bus. Requiring little host intervention, the SMT will monitor selected remote terminals until a pre-defined message count is reached. Generation of an interrupt alerts the host that SMT service is required.

1.3.1 Message Information

Each message transaction generates a Message Information Word. This information helps determine message validity and remote terminal health. The Message Information Word is stored in external memory along with message data words.

1.4 Remote Terminal/Monitor Terminal Feature

For those applications that require the SMT to transfer or receive information, the μ MMIT is configured as both a remote terminal (SRT) and monitor (SMT). This feature allows the SMT to communicate on the bus as an RT, and monitor bus activity. Configuration as both SMT and SRT precludes the SMT from monitoring its own remote terminal address.

1.5 Protocol Definition

For maximum flexibility, the μ MMIT has been designed to operate in many different systems which use various protocols. Specifically, two of the protocols that the μ MMIT may interface is MIL-STD-1553A and MIL-STD-1553B. To meet these protocols, the μ MMIT may be configured through an external pin or through control register bits.

1.6 μ MMIT LX/DX & XT Transceivers

Internal monolithic transceivers are complete transmitter and receiver pairs for MIL-STD-1553A and 1553B applications. The receiver section accepts biphasic-modulated Manchester II bipolar data from MIL-STD-1553 data bus and produces TTL-level signal data at its internal RXOUT and RXOUT outputs.

The transmitter section accepts biphasic TTL-level signal data at its internal TXIN and TXIN inputs and produces MIL-STD-1553 data signals. The transmitter's output voltage is typically $10V_{P,P,LL}$ for the μ MMIT XT5 & DX and $42V_{P,P,LL}$ for the μ MMIT XT15, XT12 & LX.

1.7 μ MMIT XT Memory

The μ MMIT XT contains 512 Kbits of internal memory for message processing. Internal logic generates a RDY signal for the subsystem interface. The internal memory is memory mapped.

ΣμMMIT FEATURES

- Comprehensive MIL-STD-1553 dual redundant Bus Controller (BC), Remote Terminal (RT), and Monitor Terminal (MT)
- Compliant MIL-STD-1553B, Notice II RT
 - Internal command illegalization in the RT mode
 - 16-bit read/write time-tag with user-defined resolution
 - Subaddress data buffering
- Simultaneous RT/MT mode of operation
- Flexible BC architecture designed to off-load the host computer
 - Minor frame timing
 - Efficient command block flow statements (Branch, Goto, Call)
 - Status word polling
 - Programmable retries
- Programmable interrupt architecture with automatic interrupt logging available in all modes
- Autonomous operation in all three modes of operation
 - Ideal for low cost remote terminals
- Built-In Test capability
- Supports IEEE Standard 1149.1 (JTAG)
- Radiation-hardened option available
- Flexible packaging offering:
 - 85-pin pingrid array (PGA)
 - 84-lead flatpack
 - 132-lead flatpack

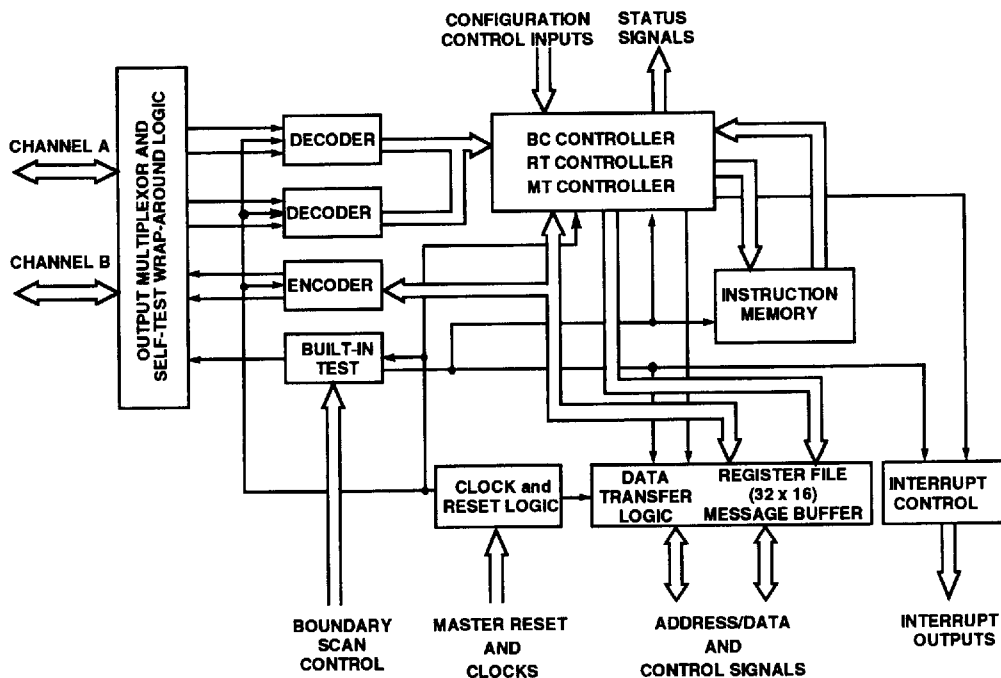

Figure 1. UT69151 ΣμMMIT Block Diagram

LX/DX FEATURES

- ❑ Comprehensive MIL-STD-1553 dual redundant Bus Controller(BC), Remote Terminal (RT), and Monitor Terminal (MT) with integrated bus transceivers
- ❑ Compliant MIL-STD-1553B, Notice II RT
 - Internal command illegalization in the RT mode
 - 16-bit read/write time-tag with user-defined resolution
 - Subaddress data buffering
- ❑ Simultaneous RT/MT mode of operation
- ❑ Flexible BC architecture designed to off-load the host computer
 - Minor frame timing
 - Efficient command block flow statements (Branch, Goto, Call)
 - Status word polling
 - Programmable retries
- ❑ Programmable interrupt architecture with automatic interrupt logging available in all modes
- ❑ Autonomous operation in all three modes of operation
 - Ideal for low cost remote terminals
- ❑ Built-In Test capability
- ❑ Supports IEEE Standard 1149.1 (JTAG)
- ❑ Flexible power supply configurations
 - +5-volt only operation
 - -15-volt and 5-volt operation
 - -12-volt and 5-volt operation
- ❑ Radiation-hardened option available (LX version only)
- ❑ Flexible packaging offering:
 - 96-pin pingrid array (PGA)
 - 100-lead flatpack
 - Complete interface in 1.4 in²

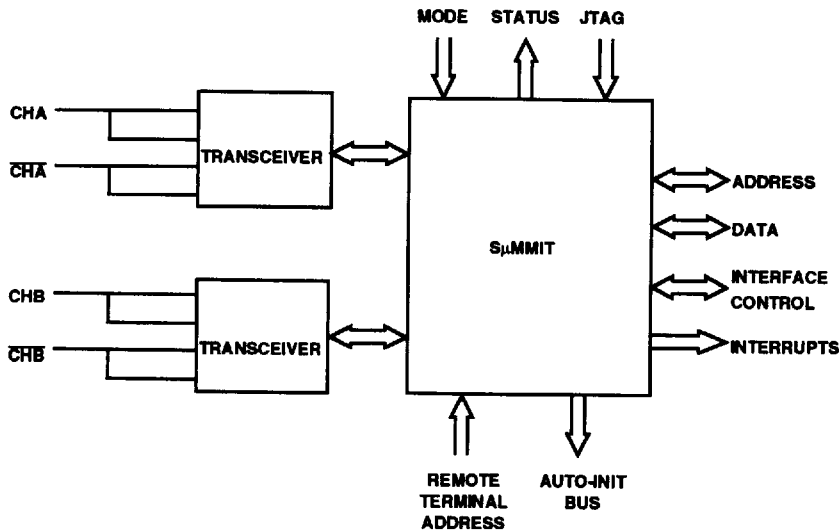

Figure 2. UT69151 S μ MMIT LX/DX Block Diagram

XT FEATURES

- Comprehensive MIL-STD-1553 dual redundant Bus Controller (BC), Remote Terminal (RT), and Monitor Terminal (MT) with integrated bus transceivers, Memory, and Memory Management Unit (MMU)
- Compliant MIL-STD-1553B, Notice II RT
 - Internal command illegalization in the RT mode
 - 16-bit read/write time-tag with user-defined resolution
 - Subaddress data buffering
- Simultaneous RT/MT mode of operation
- Flexible BC architecture designed to off-load the host computer
 - Minor frame timing
 - Efficient command block flow statements (Branch, Goto, Call)
 - Status word polling
 - Programmable retries
- Programmable interrupt architecture with automatic interrupt logging available in all modes
- Autonomous operation in all three modes of operation
 - External initialization bus
 - Ideal for low cost remote terminals
- Internal Memory Management Unit (MMU) interfaces host subsystem to 512Kbit SRAM
 - Wait state and zero-wait state configurations
- Built-In Test capability
- Supports IEEE Standard 1149.1 (JTAG)
- Flexible power supply configurations
 - +5-volt only operation
 - -15-volt and 5-volt operation
 - -12-volt and 5-volt operation
- Flexible packaging offering:
 - 139-pin pingrid array (PGA)
 - 140-lead flatpack
 - Complete interface in 1.9 in²

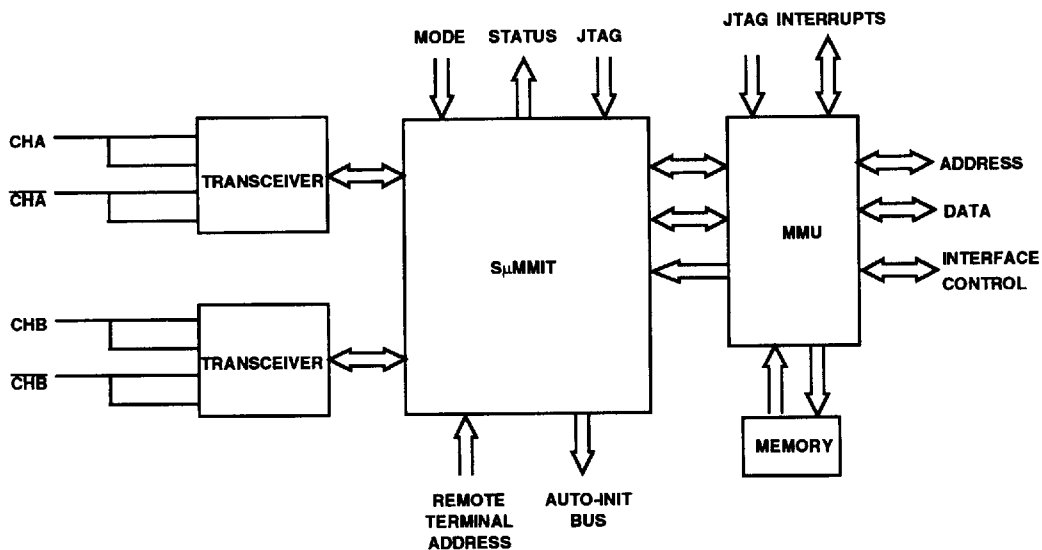

Figure 3. UT69151 S μ MMIT XT Block Diagram

2.0 REMOTE TERMINAL ARCHITECTURE

The μ MMIT Remote Terminal (SRT) is an interface device linking a MIL-STD-1553 serial data bus to a host microprocessor and/or subsystem. The SRT's MIL-STD-1553 interface includes encoding/decoding logic, error detection, command recognition, DMA interface, control/configuration registers, clock, and reset logic. The following sections review

the architecture and use. Each section supplies information on the SRT's configuration and operation.

2.1 Register Descriptions

The following list provides the bit descriptions of the 32 internal registers that control SRT operation. All register bits are active high and reflect a logic zero condition (0000 hex) after Master Reset (except those reflecting input pins).

Register Number	Name	Register Address
0	Control Register	0000 (hex)
1	Operational Status Register	0001 (hex)
2	Current Command Register	0002 (hex)
3	Interrupt Mask Register	0003 (hex)
4	Pending Interrupt Register	0004 (hex)
5	Interrupt Log List Pointer Register	0005 (hex)
6	BIT Word Register	0006 (hex)
7	Time-Tag Register	0007 (hex)
8	SRT Descriptor Pointer Register	0008 (hex)
9	1553 Status Word Bits Register	0009 (hex)
10-15	Not Applicable	000A to 000F (hex)
16-31	Illegalization Registers	0010 to 001F (hex)

Note: Reference section 9.1.2 for μ MMIT XT 8-bit register address numbers.

2.1.1 Control Register (Read/Write) - Register 0

This 16-bit register controls SRT configuration. To make changes to the SRT and this register, the STEX bit (Bit 15 of the Control Register) must be logic zero. Note: The user has 5 μ s after TERACTION active to stop execution.

Bit Number	Mnemonic	Description
15	STEX	Start Execution. Assertion of this bit initiates μ MMIT operation. A Control Register write negating this bit inhibits μ MMIT operation. A remote terminal address parity error prevents SRT operation regardless of the logical state of this bit. If an RT address parity error exists, bit 3 of Register 1 will be set low and bit 2 of Register 1 will be set high.
14	SBIT	Start BIT. Assertion of this bit places the μ MMIT into the Built-In Test routine. The BIT test has a fault coverage of 93.4%. If the μ MMIT has been started, the host must halt the device in order to place the μ MMIT into the Built-In Test routine (STEX = 0). Note: If Start BIT (SBIT) and Start Execution (STEX) are both set on one register write, BIT has priority.

Bit Number	Mnemonic	Description
13	SRST	Software Reset. Assertion of this bit immediately places the SμMMIT into a software reset. The software reset (which takes 5μs to execute), like MRST, clears all internal logic. Note: During auto-initialization this bit should not be loaded with a logic one. SRST will only function after READYB is asserted.
12	CHAEN	Channel A Enable. Setting this bit enables Channel A operation. If negated, the SRT does not recognize commands received over Channel A.
11	CHBEN	Channel B Enable. Setting this bit enables Channel B operation. If negated, the SRT does not recognize commands received over Channel B.
10	ETCE	External Timer Clock Enable. Assertion of this bit to a logic one allows the external timer clock input to supply stimulus to the internal time-tag counter. Refer to section 2.1.8 for additional information. Note: The user can only change the clock frequency before starting the device (i.e., setting bit 15 of Register 0 to a logic one).
9-7	--	See section 5, Enhanced SμMMIT Family Operation for additional information.
6	BUFR	Buffer Mode Enable. Assertion of this bit enables the buffer mode of operation. For more detailed information on this feature refer to sections 9.1.5 or 9.2.3.
5	N/A	Not Applicable.
4	BCEN	Broadcast Enable. Assertion of this bit enables the SRT broadcast option. Negation of this bit enables remote terminal address 31 as a unique remote terminal address.
3	DYNBC	Dynamic Bus Control Acceptance. This bit controls the SRT's ability to accept the dynamic bus control mode code. Assertion of this bit allows the SRT to respond to a dynamic bus control mode code with status word bit 18 set to a logic one. Negation of this bit prevents the assertion of status word bit 18 upon reception of the dynamic mode code.
2	PPEN	Ping-Pong Enable. Assertion of this bit enables the ping-pong buffer feature of the SRT and disables the message indexing feature. Negation of this bit disables the ping-pong feature and enables the message indexing feature. See section 5, Enhanced SμMMIT Family Operation for additional information.
1	INTEN	Interrupt Log Enable. Assertion of this bit enables the SμMMIT interrupt logging feature. Negation of this bit prevents the logging of interrupts.
0	XMTSW	Transmit Status Word. Assertion of this bit allows the SRT to automatically execute the TRANSMIT STATUS WORD mode code when configured for MIL-STD-1553A mode operation. Refer to section 2.9 for additional information.

2.1.2 Operational Status Register (Read/Write) - Register 1

This register reflects pertinent status information for the SRT and is not reset to 0000 (hex) on $\overline{\text{MRST}}$. Instead, the register reflects the actual stimulus applied to input pins RTA(4:0), RTPTY, MSEL(1:0), A/B STD, and LOCK. Assertion of the LOCK input prevents the modification of the remote terminal address, mode selects, and A or B Standard. In this case, a write to this register's most significant nine bits is meaningless. If LOCK is negated, a read of this register reflects the information written into this register's most significant nine bits.

Note: To make changes to the SRT and this register, the STEX bit (Bit 15 in Register 0) must be logic zero.

Bit Number	Mnemonic	Description															
15	RTA4	Terminal Address Bit 4. This bit is the most significant bit of the remote terminal address. This bit is latched on the rising edge of $\overline{\text{MRST}}$ and is a read only bit if the LOCK pin is active.															
14	RTA3	Terminal Address Bit 3. This bit is Bit 3 of the remote terminal address. This bit is latched on the rising edge of $\overline{\text{MRST}}$ and is a read only bit if the LOCK pin is active.															
13	RTA2	Terminal Address Bit 2. This bit is Bit 2 of the remote terminal address. This bit is latched on the rising edge of $\overline{\text{MRST}}$ and is a read only bit if the LOCK pin is active.															
12	RTA1	Terminal Address Bit 1. This bit is Bit 1 of the remote terminal address. This bit is latched on the rising edge of $\overline{\text{MRST}}$ and is a read only bit if the LOCK pin is active.															
11	RTA0	Terminal Address Bit 0. This bit is the least significant bit of the remote terminal address. This bit is latched on the rising edge of $\overline{\text{MRST}}$ and is a read only bit if the LOCK pin is active.															
10	RTPTY	Terminal Address Parity Bit. This bit is appended to the remote terminal address bus (RTA(4:0)) to supply odd parity. The SRT requires odd parity for proper operation. This bit is latched on the rising edge of $\overline{\text{MRST}}$ and is a read only bit if the LOCK pin is active.															
9	MSEL(1)	Mode Select 1. In conjunction with MSEL0, this bit determines the Σ MMIT mode of operation. This bit is latched on the rising edge of $\overline{\text{MRST}}$ and is a read only bit if the LOCK pin is active.															
8	MSEL(0)	Mode Select 0. In conjunction with MSEL1, this bit determines the Σ MMIT mode of operation. This bit is latched on the rising edge of $\overline{\text{MRST}}$ and is a read only bit if the LOCK pin is active.															
		<table border="1"> <thead> <tr> <th>MSEL(1)</th> <th>MSEL(0)</th> <th>Mode of Operation</th> </tr> </thead> <tbody> <tr> <td>0</td> <td>0</td> <td>SBC</td> </tr> <tr> <td>0</td> <td>1</td> <td>SRT</td> </tr> <tr> <td>1</td> <td>0</td> <td>SMT</td> </tr> <tr> <td>1</td> <td>1</td> <td>SMT/SRT</td> </tr> </tbody> </table>	MSEL(1)	MSEL(0)	Mode of Operation	0	0	SBC	0	1	SRT	1	0	SMT	1	1	SMT/SRT
MSEL(1)	MSEL(0)	Mode of Operation															
0	0	SBC															
0	1	SRT															
1	0	SMT															
1	1	SMT/SRT															
7	A/B STD	Military Standard 1553A or 1553B Standard. This bit determines whether the SRT will be set to operate under MIL-STD-1553A or B. Assertion of this bit enables the XMTSW bit (Bit 0 of the Control Register). Negation of this bit automatically allows the SRT to operate under the MIL-STD-1553B protocol. This bit is latched on the rising edge of $\overline{\text{MRST}}$ and is a read only bit if the LOCK pin is active. See section 2.9 for further definition.															
6	LOCK	LOCK Pin. This read-only bit reflects the inverted state of input pin LOCK and is latched on the rising edge of $\overline{\text{MRST}}$.															
5	AUTOEN	AUTOEN Pin. This read-only bit reflects the inverted state of input pin AUTOEN. Assertion of this input enables SRT auto-initialization.															
4	SSYSF	SSYSF Pin. This read-only bit reflects the inverted state of the input pin SSYSF.															

Bit Number	Mnemonic	Description
3	EX	SμMMIT Executing. This read-only bit indicates whether the SRT is presently executing or whether it is idle. A logic one indicates that the SμMMIT is executing; logic zero indicates that the SμMMIT is idle.
2	TAPF	Terminal Address Parity Fail. This bit indicates the observance of a terminal address parity error. The SRT checks for odd parity. This read only bit reflects the parity of Operational Status Register bits 15-10, and is latched on the rising edge of MRST .
1	READY	READY Pin. This read-only bit reflects the inverted state of the output pin READY and is cleared on reset.
0	TERACT	TERACT Pin. Assertion of this bit indicates that the SRT is presently processing a message. This read only bit reflects the inverted state of output pin TERACT and is cleared on reset.

Note: Remote Terminal Address and Parity checked on start of execution.

2.1.3 Current Command Register (Read-only) - Register 2

This 16-bit register contains the last valid command processed by the SRT.

Bit Number	Mnemonic	Description
15 to 0	CC15-CC0	Current Command Bits. This register contains the last valid command received by the SRT. This register is valid 13μs after TERACT is negated. (Bit 15 MSB - Bit 0 LSB).

2.1.4 Interrupt Mask Register (Read/Write) - Register 3

The SRT interrupt architecture allows for the masking of all interrupts. An interrupt is masked if the corresponding bit of this register is set to logic zero. This feature allows the host or subsystem to temporarily disable the service of interrupts. While masked, interrupt activity does not occur. The unmasking of an interrupt after the event occurs does not generate an interrupt for that event.

Bit Number	Mnemonic	Description
15	DMAF	DMA Fail Interrupt
14	WRAPF	Wrap Fail Interrupt
13	TAPF	Terminal Address Parity Fail Interrupt
12	BITF	BIT Fail Interrupt
11	MERR	Message Error Interrupt
10	SUBAD	Subaddress Accessed Interrupt
9	BDRCV	Broadcast Command Received Interrupt
8	IXEQ0	Index Equal Zero Interrupt
7	ILLCMD	Illegal Command Interrupt
6-0	N/A	Not Applicable

2.1.5 Pending Interrupt Register (Read-only) - Register 4

The Pending Interrupt Register contains information that identifies events that generate interrupts. The assertion of any bit in this register asserts an output pin, `MSG_INT` or `YF_INT` (three clock cycles). Writing to the most significant 4 bits of this register generates a `YF_INT`.

Bit Number	Mnemonic	Description
15	DMAF	DMA Fail Interrupt. Once the SμMMIT issues the \overline{DMAR} signal, an internal timer starts. If all DMA activity (which includes \overline{DMAR} to \overline{DMAG} , and all wait states) is not completed by the time the counter decrements to zero, the interrupt is generated. In the SRT mode, the $\overline{YF_INT}$ interrupt is generated (if not masked), current command processing ends, and the SRT will remain on-line. Current cycle terminated, bus released.
14	WRAPF	Wrap Fail Interrupt. The SRT automatically compares the transmitted word (encoder word) to the reflected decoder word via the continuous loop-back feature. If the encoder word and reflected word do not match, the \overline{WRAPF} bit is asserted in the BIT Word Register and a $\overline{YF_INT}$ interrupt is generated (if not masked). The loop-back path is via the MIL-STD-1553 bus transceiver.
13	TAPF	Terminal Address Parity Fail Interrupt. This bit reflects the outcome of the remote terminal address parity check. A logic one indicates a parity failure. When a parity error occurs, the SRT does not begin operation (STEX bit forced to logic zero), channel A and B do not enable, the TAPF bit is asserted here and in the BIT Word Register, and a $\overline{YF_INT}$ interrupt is generated (if not masked).
12	BITF	BIT Fail Interrupt. Assertion of this bit indicates a BIT failure. Status word bit 19 is automatically set to a logic one when a BIT failure occurs. If a BIT fails, the BITF bit is asserted here and in the BIT Word Register, and a $\overline{YF_INT}$ interrupt is generated (if not masked). Operation continues.
11	MERR	Message Error Interrupt. Assertion of this bit indicates that a message error condition exists. The SRT can detect Manchester errors, sync-field, word count errors (too many or too few), MIL-STD-1553 word parity errors, bit count errors (too many or too few), and protocol errors. If not masked, this bit is always set when the SRT asserts bit 9 of the status word (e.g., illegal commands, invalid data word, etc.). $\overline{MSG_INT}$ interrupt generated (if not masked).
10	SUBAD	Subaddress Accessed Interrupt. Assertion of this bit indicates a pre-selected subaddress has transacted a message. To determine the exact subaddress, the host interrogates the interrupt log IAW. $\overline{MSG_INT}$ interrupt generated (if not masked).
9	BDRCV	Broadcast Command Received Interrupt. This bit is set to a logic one to indicate the SRT's receipt of a valid broadcast command. The SRT suppresses status word transmission. $\overline{MSG_INT}$ interrupt generated (if not masked).
8	IXEQ0	Index Equal Zero Interrupt. The SRT asserts this bit to indicate the completion of a pre-defined number of commands by the SRT. Upon assertion of this interrupt, the host or subsystem updates the subaddress descriptor to prevent the potential loss of data. $\overline{MSG_INT}$ interrupt generated (if not masked).
7	ILLCMD	Illegal Command Interrupt. This bit is set to a logic one to indicate the reception of an illegal command by the SRT. Upon receipt of this command, the SRT responds with a status word only; Bit 9 of the status word is set to a logic one. $\overline{MSG_INT}$ interrupt generated (if not masked).
6-0	N/A	Not Applicable.

Note: The user must read or write a SμMMIT register after reading the Pending Register to invoke the automatic clear of the Pending Interrupt Register. For example, a Subaddress Access interrupt results in a Pending Interrupt Register of 0400_{16} . A read of the Pending Interrupt Register returns a value of 0400_{16} . A subsequent read of the Interrupt Mask Register (i.e., Register 3), followed by a Pending Interrupt Register read returns a value of 0000_{16} . The intervening read of the Interrupt Mask Register clears the Pending Interrupt Register at the end of the Interrupt Mask Register read.

2.1.6 Interrupt Log List Pointer Register (Read/Write) - Register 5

The Interrupt Log List Pointer indicates the starting address of the Interrupt Log List. The Interrupt Log List is a 32 word ring-buffer that contains information pertinent to the service of interrupts. The S μ MMIT architecture requires the location of the Interrupt Log List on a 32-word boundary. The most significant 11 bits of this register designate the location of the Interrupt Log List within a 64K memory space. The lower 5 bits of this register should be initialized to a logic zero. The S μ MMIT controls the lower 5 bits to implement the ring-buffer architecture. The host or subsystem reads this register to determine the location and number of interrupts within the Interrupt Log List (least significant 5 bits).

Note: Bits 15-5 indicate the starting Base address while bits 4-0 indicate the ring location of the Interrupt Log List. See section 6.0 for a description of the Interrupt Architecture.

Bit Number	Mnemonic	Description
15-0	INTA(15:0)	Interrupt Log List Pointer Bits. (Bit 15 MSB - Bit 0 LSB).

2.1.7 BIT Word Register (Read/Write) - Register 6

This register contains information on the SRT's current health. The SRT transmits the contents of this register upon reception of a Transmit Bit Word Mode Code. The lower 8 bits of this register are user-defined.

Bit Number	Mnemonic	Description
15	DMAF	DMA Fail. This bit is set if all DMA activity is not completed between the time DMAR asserts and when the timer decrements to zero. The DMA activity includes DMAR to DMAG and all wait states. In the event of a DMA failure, current message processing terminates; remote terminal waits for next 1553 message.
14	WRAPF	Wrap Fail. The SRT automatically compares the transmitted word (encoder word) to the reflected decoder word via the continuous loop-back feature. If the encoder word and reflected word do not match, the WRAPF bit asserts and a YF_INT interrupt is generated (if not masked). The loop-back path is via the MIL-STD-1553 bus transceiver. A wrap failure does not result in the terminal flag bit being set to a logical one. Message processing continues.
13	TAPF	Terminal Address Parity Fail. This bit reflects the outcome of the remote terminal address parity check. A logic one indicates a parity failure. When a parity error occurs the SRT does not begin operation (STEX bit forced to a logic zero), channel A and B do not enable, and a YF_INT interrupt is generated (if not masked).
12	BITF	BIT Fail. Assertion of this bit indicates a BIT failure. Bits 11 through 8 should be interrogated to determine the specific failure. Status word bit 19 is automatically set to a logic one when a BIT failure occurs. If a BIT fails, the BITF bit is asserted, and a YF_INT interrupt is generated (if not masked). Operation continues.
11	CHAF	Channel A Fail. Assertion of this bit indicates a BIT test failure in Channel A.
10	CHBF	Channel B Fail. Assertion of this bit indicates a BIT test failure in Channel B.
9	MSBF/UDB	Memory Test Fail. Most significant memory byte failure (S μ MMIT XT). User-Defined Bits (S μ MMIT & S μ MMIT LX/DX).
8	LSBF/UDB	Memory Test Fail. Least significant memory byte failure (S μ MMIT XT). User-Defined Bits (S μ MMIT & S μ MMIT LX/DX).
7-0	UDB(7:0)	User-Defined Bits.

2.1.8 Time-Tag Register (Read/Write) - Register 7

The Time-Tag Register reflects the state of a 16-bit free running counter. The resolution of this counter is user-defined via input TCLK or fixed at 64 μ s/bit. The Time-Tag counter is automatically reset when the SRT receives a valid synchronize without data mode code. The SRT automatically loads the Time-Tag counter with the data associated with reception of a valid synchronize with data mode code. The Time-Tag counter begins operation on the rising edge of MRST or within 64 μ s; after the receipt of a valid mode code, reset remote terminal, or sync with/without data. When the SRT is halted (STEX = 0), the Time-Tag continues to run. Time-Tag value is captured upon command word-validation.

Bit Number	Mnemonic	Description
15-0	TT(15:0)	Time-Tag Counter Bits. (Bit 15 MSB - Bit 0 LSB)

2.1.9 Remote Terminal Descriptor Pointer Register (Read/Write) - Register 8

The SRT accesses a block of external memory to gain information on how to process a valid command. Each subaddress and mode code has a block of memory reserved for this task. Located contiguously in memory, these reserved memory locations are called a descriptor space. The Remote Terminal Descriptor Pointer Register contains an address that points to the top of this memory space. The SRT uses the T/R bit, subaddress/mode code field, and mode code to select one block within the descriptor table for message processing. The Remote Terminal Descriptor Pointer Register is static during message processing.

Bit Number	Mnemonic	Description
15-0	RTDA(15:0)	Remote Terminal Descriptor Address Bits. (Bit 15 MSB - Bit 0 LSB)

2.1.10 1553 Status Word Bus Register (Read/Write) - Register 9

The host or subsystem accesses this register to control the outgoing MIL-STD-1553 status word. The host or subsystem controls the Instrumentation, Busy, Terminal Flag, Service Request, and Subsystem Flag by writing to bits 9 through 0 of this register. The SRT's status word response reflects assertion of these bit(s) until negated by the host or subsystem unless the Immediate Clear Function is enabled. The Immediate Clear Function automatically clears these bits after being transmitted in a status word.

The Immediate Clear Function does not affect the operation of the Transmit Status word and Transmit Last Command word Mode Codes. Transaction of a legal valid command with the INS bit set to a logic one and the Immediate Clear Function enabled, results in the transmission of a status word with Bit 10 asserted. If the ensuing command is a Transmit Status word or Last Command mode code, Bit 10 of the outgoing status word remains a logic one. For MIL-STD-1553B applications, the register is as follows:

Bit Number	Mnemonic	Description
15	IMCLR	Immediate Clear Function. Assertion of this bit enables the Immediate Clear Function (IMF) of the SRT. Enabling the IMF results in the clearing of the INS, BUSY, TF, SRQ, and/or SUBF bit immediately after a message is completed. This function is enabled by asserting this bit when asserting bit(s) INS, BUSY, TF, SRQ, and/or SSYSF. This bit should be used consistently since once set, it will remain set, and once cleared, it will remain cleared.
14-10	N/A	Not Applicable.
9	INS	Instrumentation Bit. This bit asserts the Instrumentation bit of the MIL-STD-1553B status word. (Bit 10 of the Status Word).
8	SRQ	Service Request Bit. This bit asserts the Service Request bit of the MIL-STD-1553B status word. (Bit 11 of the Status Word).
7-4	N/A	Not Applicable.
3	BUSY	Busy Bit. Assertion of this bit is reflected in the outgoing MIL-STD-1553B status word. Assertion of this bit prevents memory accesses. (Bit 16 of the Status Word).
2	SSYSF	Subsystem Flag Bit. This bit asserts the Subsystem Flag bit of the MIL-STD-1553B status word and may also be set with the SSYSF input pin. (Bit 17 of the Status Word).
1	N/A	Not Applicable.
0	TF	Terminal Flag. Assertion of this bit is reflected in the outgoing MIL-STD-1553B status word. The SRT automatically asserts this bit if a BIT failure occurs. Inhibit Terminal Flag mode code prevents the assertion by the host or subsystem. Override Inhibit Terminal Flag Mode Code re-establishes the Terminal Flag option (Bit 19 of the Status Word).

For MIL-STD-1553A applications, the register is as follows:

Bit Number	Mnemonic	Description
15	IMCLR	Immediate Clear Function. Assertion of this bit enables the Immediate Clear Function (IMF) of the SRT. Enabling the IMF results in the clearing of the bit times 10-19 immediately after a status word is transmitted. This function is enabled by asserting this bit when asserting bit times 10-19. This bit should be used consistently since once set, it will remain set, and once cleared, it will remain cleared.
14-10	N/A	Not Applicable.
9	SB10	Status bit time 10.
8	SB11	Status bit time 11.
7	SB12	Status bit time 12.
6	SB13	Status bit time 13.
5	SB14	Status bit time 14.
4	SB15	Status bit time 15.
3	SB16	Status bit time 16.
2	SB17	Status bit time 17.
1	SB18	Status bit time 18.
0	SB19	Status bit time 19.

2.1.11 Illegalization Registers

The 16 registers are divided into 8 blocks, 2 registers per block (see table 1).

Table 1. Illegalization Register Blocks

Block Name	Address (hex)
Receive	0010 and 0011
Transmit	0012 and 0013
Broadcast Receive	0014 and 0015
Broadcast Transmit (Automatically Illegalized)	0016 and 0017
Mode Code Receive	0018 and 0019
Mode Code Transmit	001A and 001B
Broadcast Mode Code Receive	001C and 001D
Broadcast Mode Code Transmit	001E and 001F

The blocks correspond to the following types of commands. Register address 0010 (hex) and 0011 (hex) illegalize receive commands to 32 subaddresses. The most significant bit of register 0010 (hex) controls the illegalization of subaddress 01111. The least significant bit controls subaddress 00000. Register 0011 (hex) controls illegalization of subaddresses 10000 through 11111. The least significant bit relates to subaddress 10000; the most significant bit relates to subaddress 11111. Transmit commands and broadcast commands (both receive and transmit) use the same encoding scheme as receive subaddress illegalization.

Registers 18 (hex) through 1F (hex) control the illegalization of mode codes. Register 18 governs the illegalization of receive mode codes (T/R bit = 0) 00000 through 01111 and register 19 mode codes 10000 through 11111. Register blocks Transmit Mode Code (T/R bit = 1), Broadcast Receive Mode Codes, and Broadcast Transmit Mode Codes use the same decode scheme as receive mode codes.

Table 2 shows the illegalization register map. For each block, the numbers shown in the column under each bit number identifies the specific subaddress or mode code (in hex) that the register bit illegalizes (Logical 0 = legal, Logical 1 = illegal).

Table 2. Illegalization Register Map

Name	Register Number	15	14	13	12	11	10	9	8	7	6	5	4	3	2	1	0
Receive	16	0F	0E	0D	0C	0B	0A	09	08	07	06	05	04	03	02	01	00
	17	1F	1E	1D	1C	1B	1A	19	18	17	16	15	14	13	12	11	10
Transmit	18	0F	0E	0D	0C	0B	0A	09	08	07	06	05	04	03	02	01	00
	19	1F	1E	1D	1C	1B	1A	19	18	17	16	15	14	13	12	11	10
Brd Receive	20	0F	0E	0D	0C	0B	0A	09	08	07	06	05	04	03	02	01	00
	21	1F	1E	1D	1C	1B	1A	19	18	17	16	15	14	13	12	11	10
Brd Transmit	22	XX	XX	XX	XX	XX	XX	XX	XX	XX	XX	XX	XX	XX	XX	XX	XX
	23	XX	XX	XX	XX	XX	XX	XX	XX	XX	XX	XX	XX	XX	XX	XX	XX
Mode Receive	24	0F	0E	0D	0C	0B	0A	09	08	07	06	05	04	03	02	01	00
	25	1F	1E	1D	1C	1B	1A	19	18	17	16	15	14	13	12	11	10
Mode Transmit	26	0F	0E	0D	0C	0B	0A	09	08	07	06	05	04	03	02	01	00
	27	1F	1E	1D	1C	1B	1A	19	18	17	16	15	14	13	12	11	10
Mode Brd Receive	28	0F	0E	0D	0C	0B	0A	09	08	07	06	05	04	03	UU	01	WW
	29	1F	1E	1D	1C	1B	1A	19	18	17	16	15	14	13	12	11	10
Mode Brd Transmit	30	0F	0E	0D	0C	0B	0A	09	08	07	06	05	04	03	ZZ	01	XX
	31	YY	YY	YY	YY	YY	YY	YY	YY	YY	YY	YY	YY	YY	YY	YY	YY

Notes:

1. Brd = Broadcast.
2. Mode = Mode code.
3. XX= Automatically illegalized by SRT.
4. YY= Automatically illegalized by SRT in 1553B only.
5. ZZ= Automatically illegalized by SRT in 1553B and 1553A if XMTSW is enabled.
6. WW = Automatically illegalized in 1553A.
7. UU = Automatically illegalized in 1553A if XMTSW enabled.

2.2 Descriptor Block

To process messages, the SRT uses data supplied in the internal registers with data stored in external memory. The SRT accesses a four word descriptor block stored in external memory. The descriptor block is accessed at the beginning and end of command processing. Multiple descriptor blocks are sequentially entered into memory to form a descriptor table. The following paragraphs discuss the descriptor block in detail.

The host or subsystem controlling the SRT allocates 512 consecutive memory spaces for the subaddress and mode code descriptor table. The top of the descriptor table can reside at any address location. Defined and entered into memory by the host, the SRT is linked to the descriptor table via the Descriptor Address Register contents (see figures 4a and 4b). Each descriptor block contains a Control Word, Data Pointer A, Data Pointer B, and Broadcast Data Pointer. Each subaddress and mode code is assigned a descriptor for receive and transmit commands (T/R bit equal zero or one).

Control word information allows the SRT to generate interrupts, buffer messages, and control message processing. For a receive command, the Data List Pointer is read to determine the top of the data buffer. The SRT stores data sequentially from the top of data buffer plus two locations (e.g., 0100, 0101, 0102, 0103, etc.). When processing a transmit command, the Data List Pointer is read to determine where data words are retrieved. The SRT retrieves data words sequentially from the address the Data List Pointer designates plus two address locations.

The Broadcast Data Pointer allows for separate storage of non-broadcast data from broadcast data per MIL-STD-1553B Notice II. The host or subsystem enables or disables this feature via the Control Word's least significant bit. When disabled, the non-

broadcast and broadcast data is stored via Data List Pointer A or B. For transmit commands, the Broadcast Data Pointer is not used. The SRT does not transmit any information on the receipt of a broadcast transmit command.

The SRT reads the descriptor block during command processing (i.e., after assertion of TERACTION). The SRT arbitrates for the memory bus. After receiving control of the bus, the SRT reads the control word and three Data Pointers. The SRT then surrenders control of the bus back to the bus master (i.e., negates DMACK). The SRT then begins the acquisition of data words for either transmission or storage.

After transmission or reception, the SRT begins post-processing. Command post-processing begins with arbitration for the memory bus. The SRT performs a DMA burst during post-processing. An optional interrupt log entry is performed after a descriptor update. During the descriptor update, the SRT modifies the Control Word index field and bits 4, 2, and 1, if required. The SRT updates Data Pointer A if no message errors occurred during the message transaction. Reception of a broadcast command, with no message errors, results in the update of the Broadcast Data Pointer. Neither Data Pointer A, B or Broadcast is updated if the SRT has the ping-pong mode of operation enabled.

See section 5, Enhanced SμMMIT Family Operation for additional information.

T/R	Subaddress/Mode Code Descriptors	Address Equation
0	Subaddress	Descriptor Address Register Contents + [(SA# x 4) + 0]
1	Subaddress	Descriptor Address Register Contents + [(SA# x 4) + 128]
0	Mode Codes	Descriptor Address Register Contents + [(MC# x 4) + 256]
1	Mode Codes	Descriptor Address Register Contents + [(MC# x 4) + 384]

Figure 4a. Descriptor Table

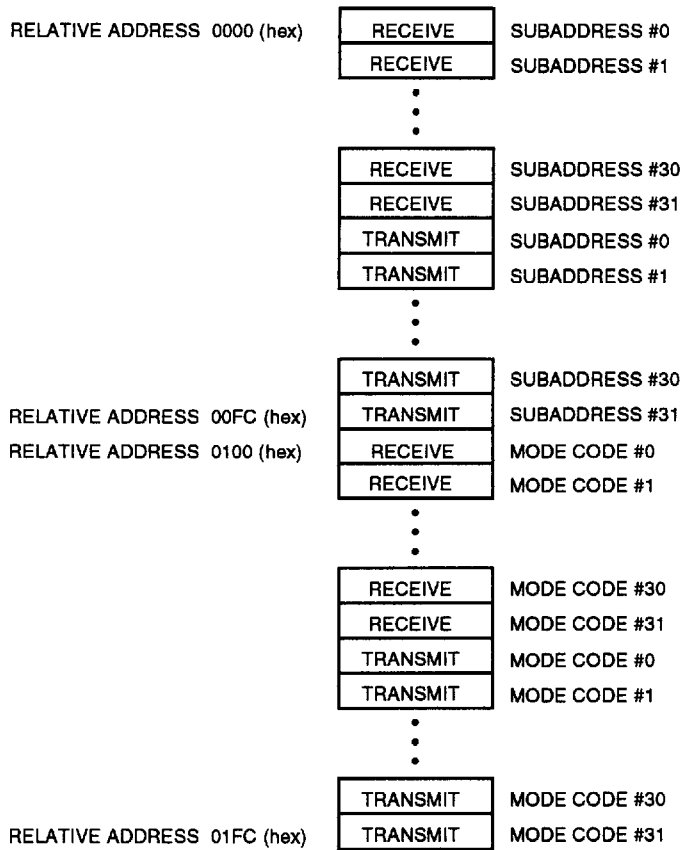

Figure 4b. Descriptor Table

2.2.1 Receive Control Word

The following bits describe the receive subaddress Descriptor Control Word. Information contained in this word assists the SRT in message processing. The Descriptor Control Word is initialized by the host or subsystem and updated by the SRT during command post-processing.

Bit Number	Mnemonic	Description
15-8	INDX	Index Field. These bits define multiple message buffer length. The host or subsystem uses this field to instruct the SRT to buffer "N" messages. "N" can range from 0 (00 hex) to 256 (FF hex). If buffer ping-ponging is enabled, the INDX field is "don't care" (i.e., does not contain applicable information). During ping-pong mode operation, initialize the index field to 00 (hex). The SRT does not perform multiple message buffering in the ping-pong mode of operation. The index decrements each time a complete message is transacted (no message errors). The index does not decrement if the subaddress is illegalized. The SRT can generate an interrupt when the index field transitions from one to zero (see bit 7).
7	INTX	Interrupt Index Equals Zero. Assertion of this bit enables the generation of an interrupt when the index field transitions from one to zero. The interrupt is entered into the Pending Interrupt Register if not masked in the Mask Register. Output pin <code>MSG_INT</code> asserts after message processing.
6	IWA	Interrupt When Accessed. Assertion of this bit enables the generation of an interrupt when the subaddress receives a valid command. The interrupt is entered into the Pending Interrupt Register if not masked in the Mask Register. Output pin <code>MSG_INT</code> asserts after message processing.
5	IBRD	Interrupt Broadcast Received. Assertion of this bit enables the generation of an interrupt when the subaddress receives a valid broadcast command. The interrupt is entered into the Pending Interrupt Register if not masked in the Mask Register. Output pin <code>MSG_INT</code> asserts after message processing.
4	BAC	Block Accessed. The subsystem or host initializes this bit to zero; the SRT overwrites the zero with a logic one upon completion of message processing. After interrogating this bit, the host resets this bit to zero to observe further accesses.
3	N/A	Not Applicable.
2	A/B	Buffer A/B. Indicates the last buffer accessed when buffer ping-pong is enabled. During initialization, the host designates the first buffer used by asserting or negating this bit. A logic one indicates buffer A; a logic zero indicates buffer B. This bit is a "don't care" if buffer ping-ponging is not enabled.
1	BRD	Broadcast Received. Assertion of this bit indicates the reception of a valid broadcast command.
0	NII	Notice II. Assertion of this bit enables the use of the Broadcast Data Pointer as a buffer for broadcast command information. When negated, broadcast information is stored in the same buffer as non-broadcast information.

2.2.2 Transmit Control Word

The following bits describe the transmit subaddress Descriptor Control Word. Information contained in this word assists the SRT in message processing. The Descriptor Control Word is initialized by the host or subsystem and updated by the SRT during command post-processing.

Bit Number	Mnemonic	Description
15-7	N/A	Not Applicable.
6	IWA	Interrupt When Accessed. Assertion of this bit enables the generation of an interrupt when the subaddress receives a valid command. The interrupt is entered into the Pending Interrupt Register if not masked in the Mask Register. Output pin <code>MSG_INT</code> asserts after message processing.
5	N/A	Not Applicable.
4	BAC	Block Accessed. The subsystem or host initializes this bit to zero, the SRT overwrites the zero with a logic one upon completion of message processing. After interrogation, the host should reset this bit to zero to observe further accesses.
3	N/A	Not Applicable.
2	A/B	Buffer A/B. Indicates the data pointer to access when buffer ping-pong is enabled. During initialization, the host designates the first buffer used by asserting or negating this bit. A logic one indicates buffer A; a logic zero indicates buffer B. This bit is a "don't care" if buffer ping-ponging is not enabled.
1	BRD	Broadcast Received. Assertion of this bit indicates the reception of a broadcast command.
0	N/A	Not Applicable.

2.2.3 Mode Code Receive Control Word

The following bits describe the receive mode code Descriptor Control Word. Information contained in this word assists the SRT in message processing. The Descriptor Control Word is initialized by the host or subsystem and updated by the SRT during command post-processing.

Note: In MIL-STD-1553A, all mode codes are without data, and the T/R bit is ignored. See section 2.9 for the MIL-STD-1553A operation.

Bit Number	Mnemonic	Description
15-8	INDX	Index Field. These bits define message buffer length. The host or subsystem uses this field to instruct the SRT to buffer "N" messages. "N" can range from 0 (00 hex) to 256 (FF hex). If buffer ping-ponging is enabled, the INDX field is "don't care" (i.e., does not contain applicable information). The SRT does not perform message buffering in the ping-pong mode of operation. The index decrements each time a complete message is transacted (no message errors). The index does not decrement if the mode code is illegalized. The SRT can generate an interrupt when the index field transitions from one to zero (see bit 7).
7	INTX	Interrupt Index Equals Zero. Assertion of this bit enables the generation of an interrupt when the index field transitions from one to zero. The interrupt is entered into the Pending Interrupt Register if not masked in the Mask Register. Output pin MSG_INT asserts after message processing.
6	IWA	Interrupt When Accessed. Assertion of this bit enables the generation of an interrupt when mode code command is received. The interrupt is entered into the Pending Interrupt Register if not masked in the Mask Register. Output pin MSG_INT asserts after message processing.
5	IBRD	Interrupt Broadcast Received. Assertion of this bit enables the generation of an interrupt when a valid broadcast mode code command is received. The interrupt is entered into the Pending Interrupt Register if not masked in the Mask Register. Output pin MSG_INT asserts after message processing.
4	BAC	Block Accessed. The subsystem or host initializes this bit to zero; the SRT overwrites the zero with a logic one upon completion of message processing. After interrogating this bit, the host resets this bit to zero to observe further accesses.
3	N/A	Not Applicable.
2	A/B	Buffer A/B. Indicates the last buffer accessed when buffer ping-pong is enabled. During initialization, the host designates the first buffer used by asserting or negating this bit. A logic one indicates buffer A; logic zero indicates buffer B. This bit is a "don't care" if buffer ping-ponging is not enabled.
1	BRD	Broadcast Received. Assertion of this bit indicates the reception of a valid broadcast command.
0	NII	Notice II. Asserting this bit enables the use of the Broadcast Data Pointer as a buffer for broadcast command information. When negated, broadcast information is stored in the same buffer as non-broadcast information.

2.2.4 Mode Code Transmit Control Word

The following bits describe the transmit mode code Descriptor Control Word. Information contained in this word assists the SRT in message processing. The Descriptor Control Word is initialized by the host or subsystem and updated by the SRT during command post-processing.

Note: In MIL-STD-1553A, all mode codes are without data, and the T/R bit is ignored. See section 2.9 for the MIL-STD-1553A operation.

Bit Number	Mnemonic	Description
15-7	N/A	Not Applicable.
6	IWA	Interrupt When Accessed. Assertion of this bit enables the generation of an interrupt when mode code command is received. The interrupt is entered into the Pending Interrupt Register if not masked in the Mask Register. Output pin MSG_INT asserts after message processing.
5	IBRD	Interrupt Broadcast Received. Assertion of this bit enables the generation of an interrupt when a valid broadcast mode code is received. The interrupt is entered into the Pending Interrupt Register if not masked in the Mask Register. Output pin MSG_INT asserts after message processing.
4	BAC	Block Accessed. The subsystem or host initializes this bit to zero; the SRT overwrites the zero with a logic one upon completion of message processing. After interrogating this bit, the host resets this bit to zero to observe further accesses.
3	N/A	Not Applicable.
2	A/B	Buffer A/B. This bit indicates the last buffer accessed when buffer ping-pong is enabled. During initialization, the host designates the first buffer used by asserting or negating this bit. A logic one indicates buffer A; a logic zero indicates buffer B. This bit is a "don't care" if buffer ping-ponging is not enabled.
1	BRD	Broadcast Received. Assertion of this bit indicates the reception of a broadcast command.
0	N/A	Not Applicable.

2.2.5 Data Pointer A and B

Data List Pointer A and B contain address information for the retrieval and storage of message data words. In the index mode of operation, the SRT reads Data Pointer A to determine the location of data for retrieval or storage. The SRT uses the Data Pointer to initialize an internal counter; the counter increments after each data word. For a receive command, the SRT stores the incoming data word sequentially into memory. As part of command post-processing, the SRT writes a new data pointer into the descriptor block. The SRT continues to update the data pointer until the Control Word index field decrements to zero. An example is shown in figure 5.

Note: The index feature is not applicable for transmit commands (i.e., T/\bar{R} bit = 1).

For ping-pong buffer operation, the host uses either Data Pointer A or Data Pointer B. The SRT determines which pointer to access via the state of Control Word bit 2. The SRT retrieves or stores data words from the address contained in the data pointer, automatically incrementing the data pointer as data words are received. The data pointer is never updated as part of command post-processing in the ping-pong mode of operation. See figures 6 and 7.

Bit Number	Mnemonic	Description
15-0	DP(15:0)	Data Pointer Bits. The second and third words of the descriptor block contain the data buffer location. The SRT accesses either Data Pointer A or Data Pointer B depending on the state of Control Word Bit 2 during ping-pong operation. For index operation, the SRT accesses only Data Pointer A. The SRT updates Data Pointer A after message processing is complete and the index field is not equal to zero and ping-pong operation disabled. Bit 15 is the most significant bit; bit 0 is the least significant bit.

2.2.6 Broadcast Data Pointer

The following bits describe the receive subaddress/mode code descriptor Broadcast Data Pointer. This word contains the address for the Message Information word, Time-Tag word, and data words associated with a broadcast command. The SRT automatically increments this data pointer during command post-processing, if ping-pong operation disabled.

Bit Number	Mnemonic	Description
15-0	BP(15:0)	Broadcast Data Pointer. The fourth word of the descriptor block contains the broadcast data buffer location. This pointer can reside anywhere inside of a 64K data space. The SRT accesses this pointer when Control Word bit 0 is a logic one and broadcast is enabled. Bit 15 is the most significant bit; bit 0 is the least significant bit. Note: If ping-pong is enabled, this pointer does not update. Note: When the broadcast command is followed by a Transmit Last Command or Transmit Status Word mode code, the SRT transmits a status word with bit 15 of the status word set to a logic one. The broadcast bit is cleared by reception of the next valid non-broadcast command.

2.3 Data Structures

The following sections discuss the data structures that result from command processing. For each complete message processed, the SRT generates a Message Information word and Time-Tag word. These words aid the host or subsystem

in further message processing. The Message Information word contains word count, message type, and message error information. The Time-Tag word is a 16-bit word containing the command validity time. The Time-Tag word data comes from the SRT's internal Time-Tag counter.

See section 5, Enhanced Family μ MMIT Operation for additional data structure information

Receive Subaddress #1
Descriptor Block

CONTROL WORD
DATA POINTER A
DATA POINTER B
BROADCAST

Index field contents: 02XX (hex)

Data Pointer A: 0100 (hex)

Data Pointer B: XXXX (hex)

Broadcast Data Pointer: XXXX (hex)

Command #1
Receive three words

Message Info Word
Time-Tag
Data Word #1
Data Word #2
Data Word #3

0100 (hex) Index equals two

0101 (hex)

0102 (hex)

0103 (hex)

0104 (hex) Index decrements to one

Command #2
Receive two words

Message Info Word
Time-Tag
Data Word #1
Data Word #2

0105 (hex) Index equals one

0106 (hex)

0107 (hex)

0108 (hex) Index decrements to zero
(interrupt generated if enabled)

Command #3
Receive three words

Message Info Word
Time-Tag
Data Word #1
Data Word #2
Data Word #3

0109 (hex) Index equals zero

010A (hex)

010B (hex)

010C (hex)

010D (hex) Index remains zero
(Data Pointer A = 109)

Note:
x = "don't care"

Figure 5. Non-Broadcast Receive Message Indexing

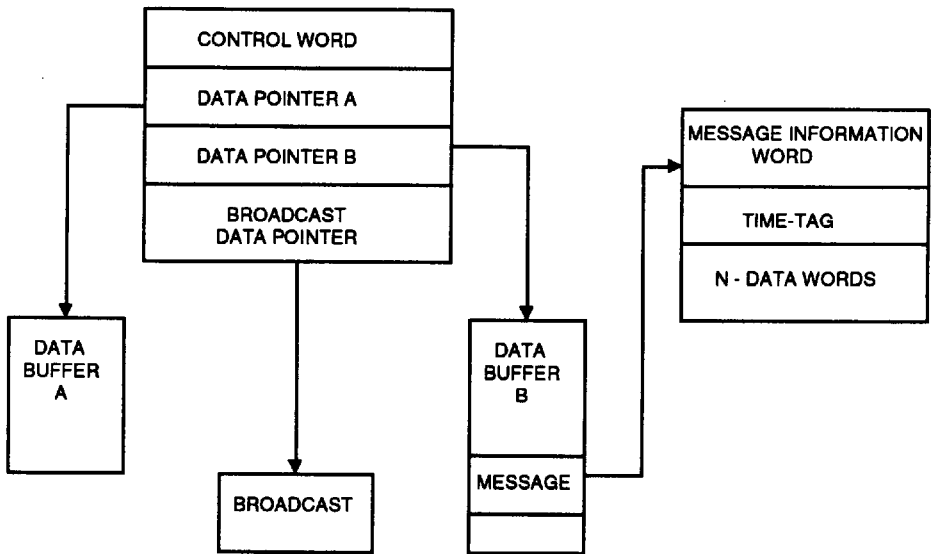

**Figure 6. SRT Descriptor Block
(Receive)**

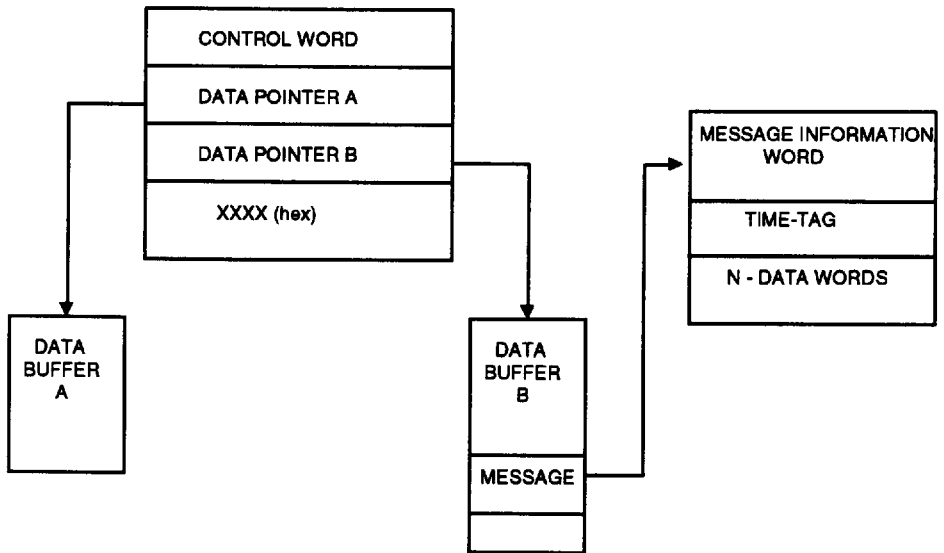

**Figure 7. SRT Descriptor Block
(Transmit)**

2.3.1 Subaddress Receive Data

For receive commands, the SRT stores data words plus two additional words. The SRT adds a Receive Information word and Time-Tag word to each receive command data packet. The SRT places the Receive Information word and Time-Tag word ahead of the data words associated with a receive command (see figures 5, 6 and 7). When message errors occur, the SRT enters the Receive Information word, and Time-Tag word. Once a message error condition is observed, all data words are considered invalid.

Data storage occurs at the memory location pointed to by the data pointer plus two locations.

2.3.1.1 Receive Information (Info) Word

The following bits describe the Receive Information Word contents.

Bit Number	Mnemonic	Description
15-11	WC(4:0)	Word Count Bits. These five bits contain word count information extracted from the receive command word bits 15 to 19.
10	N/A	Not Applicable.
9	CHA/B	Channel A/B. Assertion of this bit indicates that the message was received on channel A. Conversely, if this bit is set to logic zero, the message was received on channel B.
8	RTRT	Remote Terminal to Remote Terminal transfer. The command processed was an RT-to-RT transfer.
7	ME	Message Error. Assertion of this bit indicates a message error condition was observed during processing. See bits 0 to 4 for details.
6-5	N/A	Not Applicable.
4	ILL	Illegal Command Received. Assertion of this bit indicates the command received was an illegal command.
3	TO	Time-Out Error. Assertion of this bit indicates the SRT did not receive the proper number of data words, i.e., the number of data words received was less than the word count specified in the command word.
2	OVR	Overflow Error. Assertion of this bit indicates the SRT received a word when none was expected or the number of data words received was greater than expected.
1	PRTY	Parity Error. Assertion of this bit indicates the SRT observed a parity error in the incoming data words.
0	MAN	Manchester Error. Assertion of this bit indicates the SRT observed a Manchester error in the incoming data words.

2.3.2 Subaddress Transmit Data

The host or subsystem is responsible for organization of the data packet (i.e., N data words) into memory and establishing the applicable data pointer. The host or subsystem allocates two memory locations at the top of the data packet for the storage of the Transmit Information word and Time-Tag word. An example transmit data structure for three words is shown below.

Data Pointer A ---->	0100 (hex)	XXXX	;reserved for Transmit Info word
equals 0100 (hex)	0101 (hex)	XXXX	;reserved for Time-Tag word
	0102 (hex)	FFFF	;data word
	0103 (hex)	FFFF	;data word
	0104 (hex)	FFFF	;data word

Note: Data Pointer A points to the top of the data structure not to the top of the data words.

2.3.2.1 Transmit Information (Info) Word

The following bits describe the Transmit Information word contents.

Bit Number	Mnemonic	Description
15-11	WC(4:0)	Word Count Bits. These five bits contain word count information extracted from the receive command word bits 15 to 19.
10	N/A	Not Applicable.
9	CHA/ \bar{B}	Channel A/ \bar{B} . Assertion of this bit indicates that the message was received on the A bus. Conversely, if this bit is set to logic zero, the message was received on the B bus.
8	N/A	Not Applicable.
7	ME	Message Error. Assertion of this bit indicates a message error condition was observed during processing. See bits 0 to 4 for more detail.
6-5	N/A	Not Applicable.
4	ILL	Illegal Command Received. Assertion of this bit indicates the command received was an illegal command.
3	N/A	Not Applicable.
2	OVR	Overrun Error. Assertion of this bit indicates the SRT received a data word with a Transmit Command.
1-0	N/A	Not Applicable.

2.3.3 Mode Code Data

The transmit and receive data structures for mode codes are similar to those for subaddress. The receive data structure contains an Information word, Time-Tag word, and message data word. All receive mode codes with data have one associated data word. Data storage occurs at the memory location pointed to by the data pointer plus two locations. Reception of the synchronize with data mode code automatically loads the Time-Tag counter and stores the data word at the address defined by the data pointer plus two locations.

The transmit mode code data structure contains an Information word, Time-Tag word, and associated data word. The subsystem or host is responsible for linking the SRT Data Pointer to the data (e.g., Transmit Vector word). For mode codes with internally generated data words (e.g., Transmit BIT word, Transmit Last Command), the transmitted data word is added to the data structure.

For MIL-STD-1553A mode of operation, all mode codes are defined without data words. For mode codes without data, the data structure contains the Message Information word and Time-Tag word only.

Note: In MIL-STD-1553A, all mode codes are without data and the T/R bit is ignored. See section 2.9 for the MIL-STD-1553A operation.

2.3.3.1 Mode Code Receive Information (Info) Word

The following bits describe the Mode Code Receive Information word contents.

Bit Number	Mnemonic	Description
15-11	MC (4:0)	Mode Code. These five bits contain the mode code information extracted from the receive command word bits 15 to 19.
10	N/A	Not Applicable.
9	CHA/B	Channel A/B. Assertion of this bit indicates that the message was received on the A bus. Conversely, if this bit is set to logic zero, the message was received on the B bus.
8	RTRT	Remote Terminal to Remote Terminal transfer. Assertion of this bit indicates the command processed was an RT-to-RT transfer.
7	ME	Message Error. Assertion of this bit indicates a message error condition was observed during processing. See bits 0 to 4 for details.
6-5	N/A	Not Applicable.
4	ILL	Illegal Command Received. Assertion of this bit indicates the command received was an illegal command.
3	TO	Time-out Error. Assertion of this bit indicates the SRT did not receive the proper number of data words, i.e., the number of data words received was less than the word count specified in the command word.
2	OVR	Overflow Error. Assertion of this bit indicates the SRT received a word when none was expected, or the number of data words received was greater than expected.
1	PRTY	Parity Error. Assertion of this bit indicates the SRT observed a parity error in the incoming data words.
0	MAN	Manchester Error. Assertion of this bit indicates the SRT observed a Manchester error in the incoming data words.

2.3.3.2 Mode Code Transmit Information (Info) Word

The following bits describe the Mode Code Transmit Information word contents.

Bit Number	Mnemonic	Description
15-11	MC (4:0)	Mode Code. These five bits contain the mode code information extracted from the command word bits 15 to 19.
10	N/A	Not Applicable.
9	CHA/ \bar{B}	Channel A/ \bar{B} . Assertion of this bit indicates that the message was received on the A bus. Conversely, if this bit is set to logic zero, the message was received on the B bus.
8	N/A	Not Applicable.
7	ME	Message Error. Assertion of this bit indicates a message error condition was observed during processing. See bits 0 to 4 for details.
6-5	N/A	Not Applicable.
4	ILL	Illegal Command Received. Assertion of this bit indicates the command received was an illegal command.
3	N/A	Not Applicable.
2	OVR	Overrun Error. Assertion of this bit indicates the SRT received a data word with a Transmit Command.
1-0	N/A	Not Applicable.

2.4 Mode Code and Subaddress

The SμMMIT provides subaddress and mode code decoding that meets MIL-STD-1553B requirements. In addition, the

device has automatic internal illegal command decoding for reserved MIL-STD-1553B mode codes. Table 3 shows the SRT's response to all possible mode code combinations.

Table 3. Mode Code Descriptions

T/R	Mode Code	Function	Operation
0	00000-01111	Undefined (w/o data)	1. Command word stored 2. Status word transmitted
0	10000	Undefined (with data)	1. Command word stored 2. Data word stored 3. Status word transmitted
0	10001	Synchronize (with data)	1. Command word stored 2. Data word stored 3. Time-Tag counter loaded with data word value 4. Status word transmitted
0	10010	Undefined	1. Command word stored 2. Data word stored 3. Status word transmitted
0	10011	Undefined	1. Command word stored 2. Data word stored 3. Status word transmitted
0	10100	Selected Transmitter Shutdown	1. Command word stored 2. Data word stored 3. Status word transmitted
0	10101	Override Selected Transmitter Shutdown	1. Command word stored 2. Data word stored 3. Status word transmitted
0	10110-11111	Reserved	1. Command word stored 2. Data word stored 3. Status word transmitted
1	00000	Dynamic Bus Control	1. Command word stored 2. Dynamic Bus Acceptance bit set in outgoing status word if enabled in the Control Register 3. Status word transmitted
1	00001	Synchronize	1. Command word stored 2. Time-Tag counter reset to 0000 (hex) 3. Status word transmitted
1	00010	Transmit Status Word	1. Command word stored 2. Last status word transmitted 3. Status word cleared after master reset Note: SRT updates status word if illegalized.
1	00011	Initiate Self-Test	1. Command word stored 2. Status word transmitted 3. BIT initiated 4. TF bit set if BITF bit asserted
1	00100	Transmitter Shutdown	1. Command word stored 2. Status word transmitted 3. Alternate bus disabled

Table 3. Mode Code Descriptions (Cont.)

T/R	Mode Code	Function	Operation
1	00101	Override Transmitter Shutdown	<ol style="list-style-type: none"> 1. Command word stored 2. Status word transmitted 3. Alternate bus enabled <p>Note: Reception of the override transmitter shutdown mode code does not enable a channel not previously enabled in the Control Register. Reset remote terminal mode code clears the transmitter shutdown function.</p>
1	00110	Inhibit Terminal Flag Bit	<ol style="list-style-type: none"> 1. Command word stored 2. Terminal flag bit set to zero and assertion disabled 3. Status word transmitted
1	00111	Override Inhibit Terminal Flag	<ol style="list-style-type: none"> 1. Command word stored 2. Terminal Flag bit enabled for assertion 3. Status word transmitted
1	01000	Reset Remote Terminal	<ol style="list-style-type: none"> 1. Command word stored 2. Status word transmitted 3. SRT reset, see section 2.8 for more information on software reset
1	01001-01111	Reserved	<ol style="list-style-type: none"> 1. Command word stored 2. Status word transmitted
1	10000	Transmit Vector Word	<ol style="list-style-type: none"> 1. Command word stored 2. Service request bit set to a logic zero in out going status 3. Status word transmitted 4. Data word transmitted 5. Clears the SRQ bit in the 1553 status word bits register (Register 9)
1	10001	Reserved	<ol style="list-style-type: none"> 1. Command word stored 2. Status word transmitted 3. Data word transmitted
1	10010	Transmit Last Command	<ol style="list-style-type: none"> 1. Command word not stored 2. Last status word transmitted 3. Last command word transmitted 4. Data word stored (Transmit Last Command) 5. Transmitted data word is all zero after reset <p>Note: The SRT stores the Transmit Last Command mode code if illegalized and updates status word.</p>
1	10011	Transmit BIT Word	<ol style="list-style-type: none"> 1. Command word stored 2. Status word transmitted 3. BIT word transmitted from BIT Word Register 4. Data word stored (Transmit BIT Word)
1	10100-10101	Undefined (with data)	<ol style="list-style-type: none"> 1. Command word stored 2. Status word transmitted 3. Data word transmitted
1	10110-11111	Reserved	<ol style="list-style-type: none"> 1. Command word stored 2. Status word transmitted 3. Data word transmitted

2.5 Encoder and Decoder

The SRT interfaces directly to a transmitter/receiver via the SRT Manchester II encoder/decoder. The SRT receives the command word from the MIL-STD-1553 bus and processes it either by the primary or secondary decoder. Each decoder checks for the proper sync pulse and Manchester waveform, edge skew, correct number of bits, and parity. If the command is a receive command, the SRT processes each incoming data word for correct format, word count, and contiguous data. If a message error is detected, the SRT stops processing the remainder of the message (i.e., DMAs), suppresses status word transmission, and asserts bit 9 (ME bit) of the status word. The SRT will track the message until proper word count is finished.

The SRT automatically compares the transmitted word (encoder word) to the reflected decoder word by way of the continuous loop-back feature. If the encoder word and reflected word do not match, the WRAPF bit is asserted in the BIT Word Register and the YF_INT will be generated, if enabled. In addition to the loop-back compare test, a timer precludes a transmission greater than 800µs by the assertion of Fail-Safe Timer (TIMERONA or TIMERONB). This timer is reset upon receipt of another command. Remote Terminal Response Time:

MIL-STD-1553A = 7µs

MIL-STD-1553B = 10µs

Data Contiguity Time-Out = 1.0µs

2.6 RT-RT Transfer Compare

The RT-to-RT Terminal Address compare logic ensures that the incoming status word's Terminal Address matches the Terminal Address of the transmitting RT specified in the command word. An incorrect match results in setting the message-error bit and suppressing transmission of the status word. (RT-to-RT transfer time-out = 55 to 59µs). The receiving SRT does not check ME or SSSSF of the transmitting remote terminal.

2.7 Terminal Address

The SRT Terminal Address is programmed via six input pins: RTA(4:0) and RTPTY. Negating MRST latches the SRT's Terminal Address from pins RTA(4:0) and parity bit RTPTY. The address and parity cannot change until the next assertion and negation of the MRST input (for LOCK = 0). The Terminal Address parity is odd; input pin RTPTY is set to a logic state to satisfy this requirement. Assertion of Operational Status Register bit 2 (TAPF) indicates incorrect Terminal Address parity. The Operational Status Register bit 2 is valid after the rising edge of MRST.

For example:

RTA(4:0) = 05 (hex) = 00101 (binary)

RTPTY = 1, Sum of 1s = 3 (odd), Operational Status Register Bit 2 = 0

RTA(4:0) = 04 (hex) = 00100 (binary)

RTPTY = 0, Sum of 1s = 1 (odd), Operational Status Register Bit 2 = 0

RTA(4:0) = 04 (hex) = 00100 (binary)

RTPTY = 1, Sum of 1s = 2 (even), Operational Status Register Bit 2 = 1

Note:

- The SRT checks the Terminal Address and parity after the SRT has been started. With Broadcast disabled, RTA(4:0)=11111 operates as a normal RT address.
- The BIT Word Register parity fail bit is valid after the SRT has been started.
- The Terminal Address is also programmed via a write to the Operational Status Register (LOCK = 1). The SRT loads the Terminal Address on the completion of the Control Register write which starts the SRT.
- YF_INT occurs if enabled.

2.8 Reset

The SµMMIT provides for several different reset mechanisms. The SµMMIT software reset (Control Register Bit 13) is equal to a master reset and takes 5µs to complete. Assertion of this bit results in the immediate reset of the SRT and termination of command processing. The host or subsystem is responsible for the re-initialization of the SRT for operation. Configuration of the device for auto-initialization frees the host or subsystem from this task.

A Reset Remote Terminal mode code (Mode Code 01000, T/R = 1) is equal to a master reset only if AUTOEN is enabled. If AUTOEN is not enabled, the reset remote terminal mode code clears the encoder/decoders, resets the time-tag, enables the channels to the programmed host state, and re-enables the Terminal Flag for assertion. This reset is performed after the transmission of the 1553 Status word. All outputs have asynchronous reset with the following exceptions: DMACK, DMAR, D(15:0), A(15:0), MSG_INT, RWR, RCS, and RRD. To reset these signals, apply two clock cycles before the rising edge of MRST.

Caution: Per the MIL-STD-1553 specification (sections 4.3.3.5.1.7.9 and 30.4.3), a remote terminal must "complete the reset function within 5 μ s following transmission of the status word." If the $\overline{\text{AUTOEN}}$ function is enabled in the μMMIT , reset may require additional time depending on the application.

2.9 MIL-STD-1553A Operation

To maximize flexibility, the μMMIT has been designed to operate in many different systems which use various protocols. Specifically, two of the protocols that the μMMIT may be interfaced to are MIL-STD-1553A and MIL-STD-1553B. To meet these protocols, the μMMIT may be configured through an external pin or through control register bits (depending on the state of the $\overline{\text{LOCK}}$ pin). Table 4 defines the three ways to program the μMMIT .

Table 4. MIL-STD-1553A Operation

$\overline{\text{A/B}} \text{ STD}$ (pin or bit)	XMTSW (bit only)	RESULT (protocol selected)
0	X	1553B response, 1553B Standard
1	0	1553A response, 1553A Standard
1	1	1553A response, Auto execute the TRANSMIT STATUS WORD mode code

When configured as a remote terminal to meet MIL-STD-1553A, the μMMIT will operate as follows:

- Responds with a status word within 7 μ s;
- Ignores the T/R bit for all mode codes;
- All mode codes are defined without data;
- All mode codes use mode code transmit control and information words;
- Mode code 00000 is defined as Dynamic Bus Control (DBC);
- Subaddress 00000 defines a mode code;
- ME and TF bits are defined in the 1553 status word; all other status word bits are programmable (i.e., NO BUSY mode, etc.);
- Broadcast of all mode codes, except Mode Code 00000 (DBC) and Mode Code 00010 (Transmit Status word if enabled), is allowed;
- To illegalize a Mode Code, the user needs to illegalize both the receive and transmit versions;
- Illegalization of row 1F (hex) is not automatic.

3.0 BUS CONTROLLER ARCHITECTURE

The μ MMIT bus controller (SBC) is an interface device linking a MIL-STD-1553 serial data bus to a host microprocessor and/or subsystem. The SBC's architecture is based on a Command Block structure and internal, programmable registers. Designed to run autonomously and reduce host overhead, the SBC's RISC-based core automatically executes data handling, message error checking, memory control, and related protocol functions. This section discusses the following SBC features and functions:

- Multiple Message Processing
- Message Scheduling
- Polling Capability
- Executable Architecture
- Built-In Test
- Interrupt Structure
- Memory Management

3.1 Register Descriptions

To initialize the μ MMIT as a bus controller, the designer must understand the internal registers. The SBC registers offer many programmable functions and allow host access to extensive information. All register bits are active high and reflect a logic zero condition (0000 hex) after Master Reset (except those reflecting input pins). Each register associated with the bus controller mode of operation is individually described below.

Register Number	Name	Register Address
0	Control Register	0000 (hex)
1	Operational Status Register	0001 (hex)
2	Current Command Block Register	0002 (hex)
3	Interrupt Mask Register	0003 (hex)
4	Pending Interrupt Register	0004 (hex)
5	Interrupt Log List Pointer Register	0005 (hex)
6	BIT Word Register	0006 (hex)
7	Minor-Frame Timer	0007 (hex)
8	Command Block Pointer Register	0008 (hex)
9	Not Applicable	0009 (hex)
10	BC Command Block Initialization Count Register	000A (hex)
11-31	Not Applicable	000B to 001F (hex)

Note: Reference section 9.1.2 for μ MMIT XT 8-bit register address numbers.

3.1.1 Control Register (Read/Write)- Register 0

The Control Register's function is to configure the μ MMIT for operation. To make changes to the SBC and this register, the STEX bit (Bit 15) must be logic zero. To operate the μ MMIT as a bus controller (SBC), use the following bits.

Bit Number	Mnemonic	Description
15	STEX	Start Execution. Assertion of this bit commences operation of the μ MMIT. A Control Register write negating this bit inhibits operation of the μ MMIT. After execution begins, a write of logic zero will halt the SBC after completing the current opcode. Prior to halting, the SBC determines the next command block pointer address and loads the value into Register 8. For an EOL command block, Register 8 is not updated.
14	SBIT	Start BIT. Assertion of this bit places the μ MMIT into the Built-In Test routine. The BIT test has a fault coverage of 93.4%. Once the μ MMIT has been started, the host must halt the device in order to place the μ MMIT into the Built-In Test routine (STEX = 0) or use the bit opcode. Note: If Start BIT (SBIT) and Start Execution (STEX) are both set on one register write, BIT has priority.
13	SRST	Software Reset. Assertion of this bit immediately places the μ MMIT into a software reset. Like MRST, the software reset (which takes 5 μ s to execute) clears all internal logic. Note: During auto-initialization, do not load this bit with a logic one. SRST will only function after READYB is asserted.
12-11	N/A	Not Applicable.
10	ETCE	External Timer Clock Enable. Assertion of this bit enables an external clock used with an internal counter for variable minor frame timing. Refer to section 3.1.8. Note: The user can only change the clock frequency before starting the device (i.e., setting bit 15 of Register 0 to a logic one).
9	--	See section 5, Enhanced μ MMIT Family Operation, for additional information.
8-7	N/A	Not Applicable.
6	BUFR	Buffer Mode Enable. Assertion of this bit enables the buffer mode of operation. Refer to section 9.1.5 or 9.2.3 for additional information.
5	N/A	Not Applicable.
4	BCEN	Broadcast Enable. Assertion of this bit enables the broadcast option for the SBC. Negation of this bit enables the remote terminal address 31 as a unique RT address. When enabled, the SBC does not expect a status word response from the remote terminal.
3	N/A	Not Applicable.
2	PPEN	Ping-Pong Enable. This bit controls the method by which the SBC will retry messages. A logic one allows the SBC to ping-pong between buses during retries. A logic zero dictates that all retries will be performed on the programmed bus as defined in the Command Block control word. (Section 3.2.1 of this document defines the retry bit).
1	INTEN	Interrupt Log List Enable. Assertion of this bit enables the Interrupt Log List. Negation of this bit prevents the logging of interrupts as they occur.
0	N/A	Not Applicable.

3.1.2 Operational Status Register (Read/Write) - Register 1

This register provides pertinent status information for the SBC and is not reset to 0000 (hex) on $\overline{\text{MRST}}$. Instead, the register reflects the actual stimulus applied to input pins MSEL(1:0), A/B STD, and LOCK. Assertion of the LOCK input prevents the modification of the mode selects and the A or B standard bits. In this case, a write to this register's most significant nine bits is meaningless. If LOCK is negated, a read of this register reflects the information written into this register's most significant nine bits.

Note: To make changes to the SBC and this register, the STEX bit (Register 0, bit 15) must be logic zero.

Bit Number	Mnemonic	Description															
15-10	N/A	Not Applicable.															
9	MSEL(1)	Mode Select 1. In conjunction with Mode Select 0, this bit determines the S μ MMIT mode of operation.															
8	MSEL(0)	Mode Select 0. In conjunction with Mode Select 1, this bit determines the S μ MMIT mode of operation.															
		<table border="1"> <thead> <tr> <th>MSEL(1)</th> <th>MSEL(0)</th> <th>Mode of Operation</th> </tr> </thead> <tbody> <tr> <td>0</td> <td>0</td> <td>Bus Controller = SBC</td> </tr> <tr> <td>0</td> <td>1</td> <td>Remote Terminal = SRT</td> </tr> <tr> <td>1</td> <td>0</td> <td>Monitor Terminal = SMT</td> </tr> <tr> <td>1</td> <td>1</td> <td>SMT/SRT</td> </tr> </tbody> </table>	MSEL(1)	MSEL(0)	Mode of Operation	0	0	Bus Controller = SBC	0	1	Remote Terminal = SRT	1	0	Monitor Terminal = SMT	1	1	SMT/SRT
MSEL(1)	MSEL(0)	Mode of Operation															
0	0	Bus Controller = SBC															
0	1	Remote Terminal = SRT															
1	0	Monitor Terminal = SMT															
1	1	SMT/SRT															
7	A/B STD	Military Standard 1553A or 1553B. This bit determines whether the SBC will operate under MIL-STD-1553A or 1553B protocol. Assertion of this bit forces the SBC to look for all responses in 9 μ s or generate time-out errors. Negation of this bit automatically allows the SBC to operate under the MIL-STD-1553B protocol. See section 3.6 and section 5.0, Enhanced S μ MMIT Family Operation, for additional information.															
6	LOCK	LOCK Pin. This read-only bit reflects the inverted state of the LOCK input pin and is latched on the rising edge of $\overline{\text{MRST}}$.															
5	AUTOEN	$\overline{\text{AUTOEN}}$ Pin. This read-only bit defines whether or not the auto enable feature will be used in the design. This bit shows the inverse of the auto enable (AUTOEN) input pin.															
4	N/A	Not Applicable.															
3	EX	S μ MMIT Executing. This read-only bit indicates whether the SBC is presently executing or is idle. A logic one indicates that the S μ MMIT is executing; logic zero indicates the S μ MMIT is idle.															
2	N/A	Not Applicable.															
1	READY	$\overline{\text{READY}}$ Pin. This read-only bit reflects the inverted state of the output pin READY and is cleared on reset.															
0	TERACT	$\overline{\text{TERACT}}$ Pin. Assertion of this bit indicates that the SBC is presently executing. This read-only bit reflects the inverted state of output pin TERACT and is cleared on reset.															

Note: When STEX transitions from 0 to 1, EX and $\overline{\text{TERACT}}$ stay active until command processing is complete.

3.1.3 Current Command Register (Read-only) - Register 2

This register contains the last 1553 command that was transmitted by the SBC. Upon the execution of each Command Block, this register will automatically be updated. This register is updated when transmission of the Command Word begins. In an RT-RT transfer, the register will reflect the latest Command Word as it is transmitted.

Bit Number	Mnemonic	Description
15-0	CC(15:0)	Current Command. These bits contain the latest 1553 command that was transmitted by the bus controller.

3.1.4 Interrupt Mask Register (Read/Write) - Register 3

The SBC interrupt architecture allows the host to mask or temporarily disable the service of interrupts. While masked, interrupt activity does not occur. The unmasking of an interrupt after the event occurs does not generate an interrupt for that event. An interrupt is masked if the corresponding bit of this register is set to a logic zero.

Bit Number	Mnemonic	Description
15	DMAF	DMA Fail Interrupt.
14	WRAPF	Wrap Fail Interrupt.
13	N/A	Not Applicable.
12	BITF	BIT Fail Interrupt.
11	MERR	Message Error Interrupt.
10-6	N/A	Not Applicable.
5	EOL	End Of List Interrupt.
4	ILLCMD	Illogical Command Interrupt.
3	ILLOP	Illogical Opcode Interrupt.
2	RTF	Retry Fail Interrupt.
1	CBA	Command Block Accessed Interrupt.
0	N/A	Not Applicable.

3.1.5 Pending Interrupt Register (Read-only) - Register 4

This register is used to identify which of the interrupts occurred during operation. The assertion of any bit in this register asserts an output pin, `MSG_INT` or `YF_INT` (three clock cycles). Writing to the most significant four bits of this register generates a `YF_INT`.

Bit Number	Mnemonic	Description
15	DMAF	DMA Fail Interrupt. Once the <code>SμMMIT</code> has issued the <code>DMAR</code> signal, an internal timer is started. If all DMA activity (which includes <code>DMAR</code> , <code>DMAG</code> , and all <code>DTACK</code>) has not been completed, the interrupt is generated. In the SBC mode, the <code>YF_INT</code> interrupt is generated (if not masked) and command processing stops.
14	WRAPF	Wrap Fail Interrupt. The SRT automatically compares the transmitted word (encoder word) to the reflected decoder word by way of the continuous loop-back feature. If the encoder word and reflected word do not match, the <code>WRAPF</code> bit asserts and the <code>YF_INT</code> interrupt is generated (if not masked). The loop-back path is via the MIL-STD-1553 bus transceiver.
13	N/A	Not Applicable.
12	BITF	BIT Fail Interrupt. Assertion of this bit indicates a BIT failure. Interrogate Bit Word Register bits 11 and 10 to determine the specific failure. In SBC mode, the <code>YF_INT</code> interrupt is generated (if not masked) and command processing stops if initiated by opcode.
11	MERR	Message Error Interrupt. Assertion of this bit indicates the occurrence of a message error. The SBC can detect Manchester, sync-field, word count, 1553 word parity, bit count, and protocol errors. This bit will be set and an <code>MSG_INT</code> interrupt generated (if not masked) after message processing is complete.
10-6	N/A	Not Applicable.
5	EOL	End Of List Interrupt. Assertion of this bit indicates that the SBC is at the end of the command block. <code>MSG_INT</code> generated (if not masked).
4	ILLCMD	Illogical Command Interrupt. Assertion of this bit indicates that an illogical command (i.e., Transmit Broadcast or improperly formatted RT-RT message) was written into the Command Block. The SBC checks for RT-RT Terminal address field match, RT-RT transmit/receive bit mismatch and correct order, and broadcast transmit commands. If illogical commands occur, the SBC will halt execution. <code>MSG_INT</code> generated (if not masked).
3	ILLOP	Illogical Opcode Interrupt. Assertion of this bit indicates an illogical opcode (i.e., any reserved opcode) was used in the command block. The SBC halts operation if this condition occurs. <code>MSG_INT</code> generated (if not masked).
2	RTF	Retry Fail Interrupt. Assertion of this bit indicates all programmed retries failed. <code>MSG_INT</code> generated (if not masked).
1	CBA	Command Block Accessed Interrupt. Assertion of this bit indicates a command block was accessed (Opcode 1010), if enabled. <code>MSG_INT</code> generated (if not masked).
0	N/A	Not Applicable.

Note: The user must read or write a `SμMMIT` register after reading the Pending Register to invoke the automatic clear of the Pending Interrupt Register. For example, a Subaddress Access interrupt results in a Pending Interrupt Register of `040016`. A read of the Pending Interrupt Register returns a value of `040016`. A subsequent read of the Interrupt Mask Register (i.e., Register `316`), followed by a Pending Interrupt Register read returns a value of `000016`. The intervening read of the Interrupt Mask Register clears the Pending Interrupt Register at the end of the Interrupt Mask Register read.

3.1.6 Interrupt Log List Pointer Register (Read/Write) - Register 5

The Interrupt Log List Pointer indicates the starting address of the Interrupt Log List. The Interrupt Log List is a 32-word ring-buffer that contains information pertinent to the service of interrupts. The S μ MMIT architecture requires the location of the Interrupt Log List on a 32-word boundary. The most significant 11 bits of this register designate the location of the Interrupt Log List within a 64K memory space. Initialize the lower five bits of this register to a logic zero. The S μ MMIT controls the lower five bits to implement the ring-buffer architecture. The host or subsystem reads this register to determine the location and number of interrupts within the Interrupt Log List (least significant five bits).

Bit Number	Mnemonic	Description
15-0	INTA(15:0)	Interrupt Log List Pointer Bits. These bits indicate the starting location of the Interrupt Log List.

3.1.7 BIT Word Register (Read/Write) - Register 6

This register contains information on the current health of the SBC. The lower eight bits of this register are user-defined.

Bit Number	Mnemonic	Description
15	DMAF	DMA Fail. Assertion of this bit indicates that all DMA activity had not been completed from the time DMAR asserts to when the timer decrements to zero (i.e., 16 μ s). The DMA activity includes DMAR to DMAG, and all wait states. In the event of a DMA failure, current processing terminates.
14	WRAPF	Wrap Fail. The SBC automatically compares the transmitted word (encoder word) to the reflected decoder word by way of the continuous loop-back feature. If the encoder word and reflected word do not match, the WRAPF bit asserts. The loop-back path is via the MIL-STD-1553 bus transceiver.
13	N/A	Not Applicable.
12	BITF	BIT Fail. Assertion of this bit indicates a BIT failure. Interrogate bit 11 through 8 to determine the specific failure.
11	CHAF	Channel A Fail. Assertion of this bit indicates a BIT test failure in Channel A.
10	CHBF	Channel B Fail. Assertion of this bit indicates a BIT test failure in Channel B.
9	MSBF/USB	Memory Test Fail. Most significant memory byte failure (S μ MMIT XT). User-Defined Bits (S μ MMIT & S μ MMIT LX/DX).
8	LSBF/USB	Memory Test Fail. Least significant memory byte failure (S μ MMIT XT). User-Defined Bits (S μ MMIT & S μ MMIT LX/DX).
7-0	USB (7:0)	User-Defined Bits.

3.1.8 Minor Frame Timer Register (Read-only) - Register 7

This register is loaded via the Minor Frame Timer (MFT) opcode (Opcode 1110). For user-defined resolution use TCLK. Register resets to zero anytime operation halts.

Bit Number	Mnemonic	Description
15-0	MFT(15:0)	Minor Frame Timer. These bits indicate the value of the Timer.

3.1.9 Command Block Pointer Register (Read/Write) - Register 8

This register contains the location to start the Command Blocks. After execution begins, this register is automatically updated with the address of the next block.

Bit Number	Mnemonic	Description
15-0	CBA(15:0)	Command Block Address. These bits indicate the starting location of the Command Block.

3.1.10 BC Command Block Initialization Count Register (Read/Write)-Register 10

This register contains the number of command blocks that will be initialized when using the auto-initialize feature. If 0000 (hex) is written into this register, then NO blocks will be set up. Because each Command Block requires eight contiguous memory locations, the largest value allowed in this register is 1FFF (hex). If a larger value is written into this register, the SBC ignores the three most significant bits.

Bit Number	Mnemonic	Description
15-0	CBC(15:0)	Command Block Count. These bits indicate the number of Command Blocks set up during auto-initialization.

3.2 SBC Architecture

As defined in MIL-STD-1553, the bus controller initiates all communications on the bus. To meet MIL-STD-1553 bus controller requirements, the μ MMIT utilizes a Command Block architecture that takes advantage of both internal registers and external memory. Each command word transmitted over the bus must be associated with a Command Block. The Command Block requires eight contiguous memory locations for each message. These eight locations include a control word, two command word locations, a data pointer, two status word locations, a branch address location, and a timer value.

The host, or ROM for autonomous operation, must initialize each of the locations associated with each Command Block (the exception is for the two status locations which will be updated as command words are transmitted and corresponding status words are received). Figure 8 shows the SBC's Command Block architecture while Sections 3.2.1 through 3.2.6 describe each location associated with the Command Block.

Control Word
Command Word 1
Command Word 2
Data Pointer
Status Word 1
Status Word 2
Branch Address
Timer Value

Figure 8. Command Block Definition

3.2.1 Control Word

The first memory location of each SBC Command Block contains the control word. Each control word contains the opcode, retry number, bus definition, RT-RT instruction, condition codes, and the block access message error. The SBC's control word is defined below.

15	12 11	10	9	8	7	1	0
Opcode	Retry #	CHA/B	RT-RT	Condition Codes		Block Access ME	

Bit Number

Description

- 15-12 **Opcode.** These bits define the opcode to be used by the SBC for that particular Command Block. If the opcode does not perform any 1553 function, all other bits are ignored. Each of the available opcodes is defined in section 3.2.1.1.
- 11-10 **Retry Number.** These bits define the number of retries for each individual Command Block and if a retry opcode is used. If bit 2 of the Control Register is not enabled, all retries will occur on the programmed bus. However, if bit 2 is enabled, the first retry will always occur on the alternate bus, the second retry will occur on the primary bus, the third retry will occur on the alternate bus, and the fourth retry will occur on the primary bus.
- | BIT 11 | BIT 10 | # of Retries |
|--------|--------|--------------|
| 0 | 1 | 1 |
| 1 | 0 | 2 |
| 1 | 1 | 3 |
| 0 | 0 | 4 |
- 9 **Bus A/B.** This bit defines on which of the two buses the command will be transmitted (i.e., primary bus). (Logic 1 = Bus A, Logic 0 = Bus B).
- 8 **RT-RT Transfer.** This bit defines whether or not the present Command Block is an RT-RT transfer and if the SBC should transmit the second command word. Data associated with an RT-RT is always stored by the SBC (Logic 1 = RT-RT).
- 7-1 **Condition Codes.** These bits define the condition code the SBC uses for that particular Command Block. Each of the available condition codes are defined in section 3.2.1.2.
- 0 **Block Access Message Error.** Assertion of this bit indicates a protocol message error occurred in the RT's response. For this occurrence, the SBC will overwrite this bit prior to storing the Control Word into memory. Noise on the 1553 bus may be one example of such an error.

3.2.1.1 Opcode Definition

Opcode	Definition
0000	End Of List. This opcode instructs the SBC that the end of the command block has been encountered. Command processing stops and the interrupt is generated if the interrupt is enabled. No command processing takes place (i.e., no 1553).
0001	Skip. This opcode instructs the SBC to load the message-to-message timer with the value stored in timer value location. The S μ MMIT will then wait the specified time before proceeding to the next command block. This opcode allows for scheduling of specific time between message execution. No command processing takes place (i.e., no 1553).
0010	Go To. This opcode instructs the SBC to "go to" the command block as specified in the branch address location. No command process takes place (i.e., no 1553).
0011	Built-in Test. This opcode instructs the SBC to perform an internal built-in test. If the device passes the built-in test, then processing of the next command block will continue. However if the device fails the built-in test, then processing stops and an interrupt is generated, if the interrupt is enabled. No command processing takes place (i.e., no 1553).
0100	Execute Block; Continue. This opcode instructs the SBC to execute the current command block and proceed to the next command block. This opcode allows for continuous operations.
0101	Execute Block; Branch. This opcode instructs the SBC to execute the current command block and unconditionally branch to the location as specified in the branch address location.
0110	Execute Block; Branch on Condition. This opcode instructs the SBC to execute the current command block and branch only if the condition is met. If no conditions are met, the opcode appears as an execute and continue.
0111	Retry on Condition. This opcode instructs the SBC to perform automatic retries, as specified in the control word, if particular conditions occur. If no conditions are met, the opcode appears as an execute and continue.
1000	Retry on Condition; Branch. This opcode instructs the SBC to perform automatic retries, as specified in the control word, if particular conditions occur. If the conditions are met, the SBC retries. Once all retries have executed, the SBC branches to the location as specified in the branch address location. If no conditions are met, the opcode appears as an execute and branch.
1001	Retry on Condition; Branch if all Retries Fail. This opcode instructs the SBC to perform automatic retries, as specified in the control word, if particular conditions occur. If the conditions are met and all the retries fail, the SBC branches to the location as specified in the branch address location. If no conditions are met, the opcode appears as an execute and continue.
1010	Interrupt; Continue. This opcode instructs the SBC to interrupt and continue processing on the next command block. No command processing takes place (i.e., no 1553).
1011	Call. This opcode instructs the SBC to "go to" the command block as specified in the branch address location without processing this block. The next command block address is saved in an internal register so that the S μ MMIT may remember one address and return to the next command block. No command processing takes place (i.e., no 1553).
1100	Return to Call. This opcode instructs the SBC to return to the command block address saved during the Call opcode. No command processing takes place (i.e., no 1553).
1101	Reserved. The SBC will generate an illegal opcode interrupt (if interrupt enabled) and automatically stop execution if a reserved opcode is used.

Opcode	Definition
1110	Load Minor Frame Timer. This opcode instructs the SBC to load the minor frame timer (MFT) with the value stored in the eighth location of the current command block. The timer will be loaded after the previous MFT has decremented to zero. After the MFT timer is loaded with the new value, the SBC will proceed to the next command block. No command processing takes place (i.e., no 1553).
1111	Return to Branch. This opcode instructs the SBC to return to the command block address saved during a Branch opcode. No command processing takes place (i.e., no 1553).

Note: For retries with interrupts enabled, all interrupts are logged after message processing is complete.

3.2.1.2 Condition Codes

Condition codes have been provided as a means for the SBC to perform certain functions based on the RT's status word. In an RT-RT transfer, the conditions apply to both of the status words. Each bit of the condition codes is defined below.

Bit Number	Description
7	Message Error. This condition will be met if the SBC detects an error in the RT's response, or if it detects no response. (The SBC will wait 15 μ s in 1553B mode and 9 μ s in 1553A mode before declaring an RT no response.) See section 5.0, Enhanced μ MMIT Family Operation for additional information.
6	Status Word Response with the Message Error bit set (Bit time 9 in 1553A mode). This condition is met if the SBC detects that the RT's status word has the Message Error bit set.
5	Status Word Response with the Busy bit set (Bit time 16 in 1553A mode). This condition is met if the SBC detects that the RT's status word has the Busy bit set.
4	Status Word Response with the Terminal Flag bit set (Bit time 19 in 1553A mode). This condition is met if the SBC detects that the RT's status word has the Terminal Flag bit set.
3	Status Word Response with the Subsystem Fail bit set (Bit time 17 in 1553A mode). This condition is met if the SBC detects that the RT's status word has the Subsystem Fail bit set.
2	Status Word Response with the Instrumentation bit set (Bit time 10 in 1553A mode). This condition is met if the SBC detects that the RT's status word has the Instrumentation bit set.
1	Status Word Response with the Service Request bit set (Bit time 11 in 1553A mode). This condition is met if the SBC detects that the RT's status word has the Service Request bit set.

3.2.2 Command Words

The next two locations of the SBC Command Block are for 1553 command words. In most 1553 messages, only the first command word needs to be initialized. However, in an RT-RT transfer, the first command word is the Receive Command and the second command word is the Transmit Command.

3.2.3 Data Pointer

The fourth location in the SBC Command Block is the data pointer that points to the first memory location to store or fetch the data words associated with the message for that command block. This data structure allows the SBC to store or fetch the

exact specified number of data words, thus saving memory space and providing efficient space allocation. (Note: In an RT-RT transfer, the SBC uses the data pointer as the location in memory to store the transmitted data in the transfer.)

One common application for the data pointer occurs when the SBC needs to send the same data words to several RTs. Here, each Command Block associated with those messages would contain the same data pointer value, and, therefore, fetch and transmit the same data. Note that the Data Pointer is never updated (i.e., the SBC reads and writes the pointer but never changes its value).

3.2.4 Status Words

The next two locations in the SBC Command Block are for status words. As the RT responds to the BC's command, the corresponding status word will be stored in Status Word 1. In an RT-RT transfer, the first status word will be the status of the Transmitting RT while the second status word will be the status of the Receiving RT.

3.2.5 Branch Address

The seventh location in the SBC Command Block contains the starting location of the branch. This location simply allows the SBC to branch to another location in memory when certain opcodes are used.

3.2.6 Timer Value

The last location in the SBC Command Block is the Timer Value. This timer is used for one of two purposes. First, the value may be used to set up minor frame schedules when using the Load Minor Frame Timer opcode (1110). The MFT counter may be driven by the TCLK input. If not driven by the TCLK input, the MFT counter is clocked at a 64 μ s internal clock.

The MFT counter runs continuously during message processing and must decrement to zero prior to loading the next Minor Frame time value. Second, the value may be used as a message-to-message timer (MMT) when using the Skip opcode (0001). The MMT timer is clocked at the 24MHz rate and allows for scheduling of specific time between message execution.

3.3 Command Block Chaining

The host determines the first Command Block by setting the initial start address in the Command Block Pointer Register (Reg 8). The Command Blocks will execute in a contiguous fashion as long as no "go to", "branch", "call", or "return" opcodes are used. With the use of these opcodes, almost any memory configuration is possible. Figures 9a, 9b and 10 show how several Command Blocks may be linked together to form a command frame and how branch opcodes may be used to link minor frames. The minimum BC intermessage gap is 28.0 μ s.

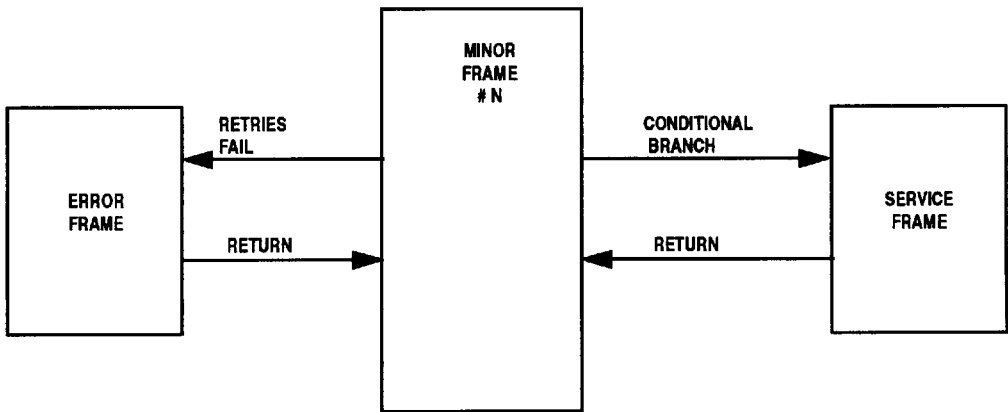

Figure 9a. Minor Frame Branching

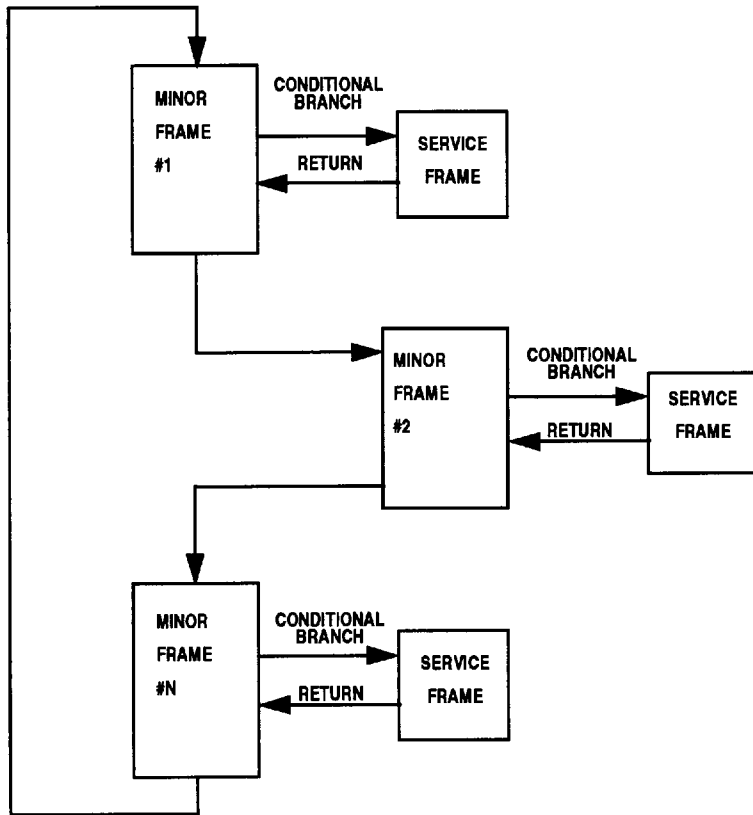

Figure 9b. Major Frame Sequencing

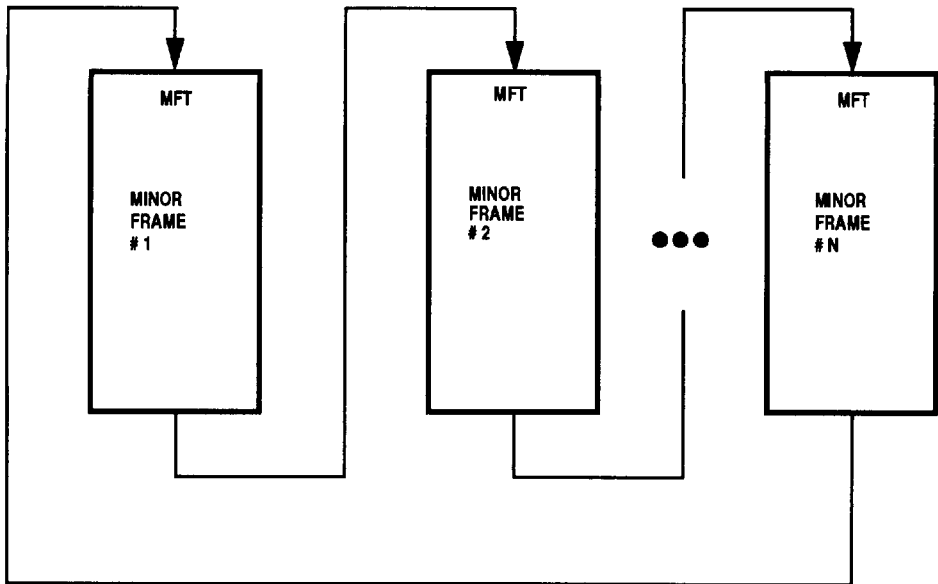

Figure 10. Major Frame Sequencing

3.4 Memory Architecture

After reviewing the SBC's internal registers, it may be advantageous to look at the external memory requirements and how the host sets up memory to make the μ MMIT a bus controller. The intent of this section is to show one method for defining the memory configuration.

The configuration shows the Command Blocks, data locations, and the Interrupt Log List as separate entities within memory. Figure 11 shows that the first block of memory is allocated for the Command Blocks. Notice that Register 8 initially points to the control word of the first Command Block. After completing execution of that first Command Block, Register 8 will automatically be updated to show the address associated with the next Command Block.

Following the Command Block locations is the memory required for all the data words. In BC applications, the number of data words for each Command Block is known. In figure 11 for example, the first Command Block has allocated several memory locations for expected data. Conversely, the second Command Block has only allocated a few memory locations. Since the number of data words associated with each Command Block is known, memory may be used efficiently.

Also, shown as a separate memory area is the Interrupt Log List (refer to section 6.0 for a description of the Interrupt Log List). Notice that Register 5 points to the top of the initial Log List. After execution of the first SBC Command Block, Register 5 will automatically be updated if interrupt condition exists.

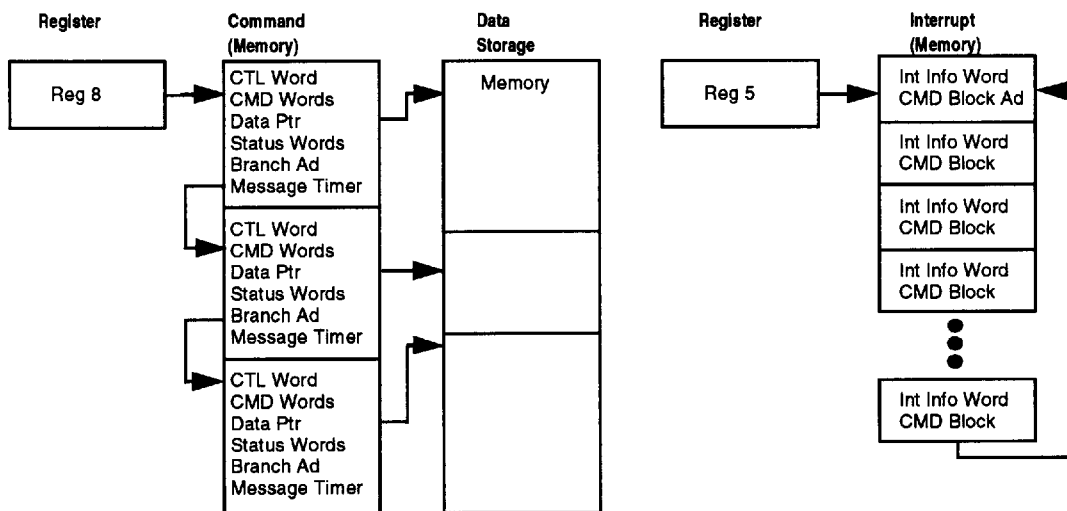

Figure 11. Memory Architecture for BC Mode

3.5 Message Processing

To process messages, the SBC uses data supplied in the internal registers along with data stored in external memory. The SBC accesses eight words stored in external memory called a command block. The command block is accessed at the beginning and end of command processing.

Note: In the SBC mode of operation, the μ MMIT does not read the Command Block for each retry situation.

The μ MMIT features two different modes of transferring data to or from RAM: Buffer and Non-Buffer. The user selects the Buffer or Non-Buffer transfer mode by setting the BUFR bit (bit 6) in the control register. See sections 9.1.5 or 9.2.3 for additional information.

The host or subsystem controlling the SBC allocates memory spaces for the minor frame. The top of the command blocks can reside at any address location. Defined and entered into memory

by the host, the SBC is linked to the Command Block via the Command Block Pointer Register contents. Each command block contains a Control Word, Command Word 1, Command Word 2, Data Pointer, Status Word 1, Status Word 2, Branch Address, and Timer Value. Refer to sections 3.2.1 - 3.2.6 for a complete description of each location.

Control word information allows the SBC to control the commands transmitted over the 1553 bus. The Control word allows the SBC to transmit commands on a specific channel, perform retries, initiate RT-RT transfers, and interrupt on certain conditions. The host or subsystem defines each command word associated with each command block. For normal 1553 commands, only the first command word location will contain valid data. For RT-RT commands, as specified in the Control word, the host must define the first command word as a receive and the second command word as a transmit.

The SBC reads the command block during minor frame processing (i.e., after assertion of $\overline{\text{TERACT}}$). The SBC arbitrates for the memory bus. After receiving control of the bus, the SBC reads all eight locations. The SBC then surrenders control of the bus (i.e., negates $\overline{\text{DMACK}}$), and begins the acquisition of data words for either transmission or storage.

For a receive command, the Data Pointer determines where data words are retrieved. The SBC retrieves data words sequentially from the address specified by the Data Pointer. For a transmit command, the Data Pointer determines the top memory location. The SBC stores data words sequentially from this top memory location.

After transmission or reception, the SBC begins post-processing. Command post-processing begins with the arbitration for the memory bus. The SBC performs a DMA burst during post-processing. An optional interrupt log entry is performed after a command block update. During the command block update, the SBC modifies the Control Word as required.

3.6 MIL-STD-1553A Operation

To maximize flexibility, the S μ MMIT has been designed to operate in many different systems which use various protocols. Specifically, two of the protocols that the S μ MMIT may be interfaced to are MIL-STD-1553A and MIL-STD-1553B. To meet these protocols, the S μ MMIT may be configured through an external pin or through control register bits (depending on the state of the LOCK pin).

Table 5. MIL-STD-1553A Operation

A/B STD (pin)	RESULT
0	1553B response, 1553B standard
1	1553A response, 1553A standard

When configured as a MIL-STD-1553A bus controller, the S μ MMIT will operate as follows:

- Looks for the RT response within 9 μ s (see section 5, Enhanced S μ MMIT Family Operation);
- Defines all mode codes without data;
- Defines subaddress 00000 as a mode code.

4.0 MONITOR TERMINAL ARCHITECTURE

In many applications, the S μ MMIT Monitor Terminal (SMT) may be required to be the Backup Bus Controller (BBC). With this in mind, the SMT architecture is designed to function like the SBC's architecture. The SMT's architecture is based on a monitor block structure and internal, programmable registers. Designed to run autonomously and reduce host overhead, the SMT automatically executes data handling, message error checking, memory control, and related protocol functions. Discussed in this section are the following monitor features and functions:

- Command History List
- Executable Architecture
- BIT Capability

- Interrupt History List
- Monitor All or Selected Terminals
- Memory Management

4.1 Register Descriptions

To initialize the S μ MMIT as a monitor terminal, the designer must understand the internal registers. A complete description of each register and the associated bits is provided. These registers offer many programmable functions and allow host access to extensive information. All register bits are active high and reflect a logic zero condition (0000 hex) after Master Reset (except those reflecting input pins). Each register associated with the monitor mode of operation is described below.

Register Number	Name	Register Address
0	Control Register	0000 (hex)
1	Operational Status Register	0001 (hex)
2	Current Command Block Register	0002 (hex)
3	Interrupt Mask Register	0003 (hex)
4	Pending Interrupt Register	0004 (hex)
5	Interrupt Log List Pointer Register	0005 (hex)
6	BIT Word Register	0006 (hex)
7	Time-Tag Register	0007 (hex)
8-10	Not Applicable	0008 to 000A (hex)
11	Initial Monitor Command Block Pointer Register	000B (hex)
12	Initial Monitor Data Pointer Register	000C (hex)
13	Monitor Block Counter Register	000D (hex)
14	Monitor Filter Register	000E (hex)
15	Monitor Filter Register	000F (hex)
16-31	Not Applicable	0010 to 001F (hex)

Note: Reference section 9.1.2 for S μ MMIT XT 8-bit register address numbers.

4.1.1 Control Register (Read/Write) - Register 0

To operate the S μ MMIT as a monitor terminal, use the following bits. To make changes to the SMT and this register, the STEX bit (Bit 15) must be logic zero.

Note: The user has 5 μ s after TERA \overline CT active to stop execution.

Bit Number	Mnemonic	Description
15	STEX	Start Execution. Assertion of this bit commences operation of the S μ MMIT. A Control Register write negating this bit inhibits operation of the S μ MMIT. After execution has begun, a write of a logic zero will halt the SMT after completing the current 1553 message.
14	SBIT	Start BIT. Assertion of this bit places the S μ MMIT into the Built-In Test routine. The BIT test has a 93.4% fault coverage. If the S μ MMIT has been started, the host must halt the device in order to place the S μ MMIT into the Built-In Test routine (STEX = 0). Note: If Start BIT (SBIT) and Start Execution (STEX) are both set on one register write, BIT has priority.
13	SRST	Software Reset. Assertion of this bit immediately places the S μ MMIT into a software reset. The software reset (which takes 5 μ s to execute) clears all internal logic, just as the MRST does. Note: During auto-initialization, do not load this bit with a logic one. SRST will only function after READY is asserted.
12-11	N/A	Not Applicable.
10	ETCE	External Timer Clock Enable. If this bit is set to logic one, the SMT will use the external input clock to drive the Time-Tag counter. If set to logic zero, the SMT will use an internal clock to drive the time tag counter. Refer to section 4.1.8 for additional information. Note: The user can only change the clock frequency before starting the device (i.e., setting bit 15 of Register 0 to a logic one).
9	--	See section 5, Enhanced S μ MMIT Family Operation.
8-7	N/A	Not Applicable.
6	BUFR	Buffer Mode Enable. Assertion of this bit enables the buffer mode of operation. For more detailed information on this feature refer to section 9.1.5 and 9.2.3.
5	SMTC	Monitor Control. This bit determines whether the SMT will monitor all RTs or selected RTs. If this bit is set to logic zero, the SMT will monitor all RTs. If this bit is set to logic one, the SMT will monitor only the RTs as specified in the Monitor Filter Registers (Registers 14 and 15).
4	BCEN	Broadcast Enable. This bit, if set to logic one, allows RT address 31 to be used as a Broadcast message. If set to logic zero, then address 31 is a normal address.
3-2	N/A	Not Applicable.
1	INTEN	Interrupt Log List Enable. Assertion of this bit enables the Interrupt Log List. Negation of this bit prevents the logging of interrupts as they occur.
0	N/A	Not Applicable.

4.1.2 Operational Status Register (Read/Write) - Register 1

This register reflects pertinent status information for the SMT and is not reset to 0000 (hex) on \overline{MRST} . Instead, the register reflects the actual stimulus applied to input pins MSEL(1:0), A/\overline{B} STD, and \overline{LOCK} . Assertion of the \overline{LOCK} input prevents the modification of the remote terminal address, mode selects, and the A or B Standard bits. In this case, a write to this register's most significant nine bits is meaningless. If \overline{LOCK} is negated, a read of this register reflects the information written into this register's most significant nine bits.

Note: To make changes to the SMT and this register, the STEX bit (Register 0, bit 15) must be logic zero.

Bit Number	Mnemonic	Description															
15-10	N/A	Not Applicable.															
9	MSEL(1)	Mode Select 1. In conjunction with Mode Select 0, this bit determines the μ MMIT mode of operation.															
8	MSEL(0)	Mode Select 0. In conjunction with Mode Select 1, this bit determines the μ MMIT mode of operation. <table border="1" style="margin-left: auto; margin-right: auto;"> <thead> <tr> <th>MSEL(1)</th> <th>MSEL(0)</th> <th>Mode of Operation</th> </tr> </thead> <tbody> <tr> <td>0</td> <td>0</td> <td>Bus Controller = SBC</td> </tr> <tr> <td>0</td> <td>1</td> <td>Remote Terminal = SRT</td> </tr> <tr> <td>1</td> <td>0</td> <td>Monitor Terminal = SMT</td> </tr> <tr> <td>1</td> <td>1</td> <td>SMT/SRT</td> </tr> </tbody> </table>	MSEL(1)	MSEL(0)	Mode of Operation	0	0	Bus Controller = SBC	0	1	Remote Terminal = SRT	1	0	Monitor Terminal = SMT	1	1	SMT/SRT
MSEL(1)	MSEL(0)	Mode of Operation															
0	0	Bus Controller = SBC															
0	1	Remote Terminal = SRT															
1	0	Monitor Terminal = SMT															
1	1	SMT/SRT															
7	A/\overline{B} STD	Military Standard 1553A or 1553B Standard. This bit determines whether the SMT will look for the RT's response in 9 μ s (MIL-STD-1553A) or in 15 μ s (MIL-STD-1553B). Assertion of this bit forces the SMT to declare a time-out error condition if the RT has not responded in 9 μ s. Negation of this bit allows the SMT to declare a time-out error condition if the RT has not responded in 15 μ s. See section 4.7 and section 5.0, Enhanced μ MMIT Family Operation, for additional information.															
6	LOCK	\overline{LOCK} Pin. This read-only bit reflects the inverted state of the \overline{LOCK} input pin. The Lock pin is latched on the rising edge of \overline{MRST} . If modes of operation must change, the user must perform a \overline{MRST} .															
5	AUTOEN	\overline{AUTOEN} Pin. This read-only bit defines whether or not the auto enable feature will be used in the design. This bit shows the inverse of the auto enable (AUTOEN) input pin.															
4	N/A	Not Applicable.															
3	EX	μ MMIT Executing. This read-only bit indicates whether the SMT is presently executing or whether it is idle. A logic one indicates that the μ MMIT is executing, logic zero idle.															
2	N/A	Not Applicable.															
1	READY	READY Pin. This read-only bit reflects the inverted state of the output pin READY and is cleared on reset.															
0	TERACT	Terminal Active Pin. Assertion of this bit indicates that the SMT is presently processing a message. This read-only bit reflects the inverted state of output pin TERACT and is cleared on reset.															

4.1.3 Current Command Register (Read-only) - Register 2

This register contains the last valid command that was transmitted over the 1553 bus. In an RT-RT transfer, this register will update as each of the two commands are received by the SMT.

Bit Number	Mnemonic	Description
15-0	CC(15:0)	Current Command. These bits contain the latest 1553 word that was received by the SMT.

4.1.4 Interrupt Mask Register (Read/Write) - Register 3

The SMT interrupt architecture allows the host or subsystem to mask or temporarily disable the service of interrupts. While masked, interrupt activity does not occur. The unmasking of an interrupt after the event occurs does not generate an interrupt for that event. An interrupt is masked if the corresponding bit of this register is set to logic zero.

Bit Number	Mnemonic	Description
15	DMAF	DMA Fail Interrupt.
14-13	N/A	Not Applicable.
12	BITF	BIT Fail Interrupt.
11	MERR	Message Error Interrupt.
10-1	N/A	Not Applicable.
0	MBC	Monitor Block Counter Interrupt.

4.1.5 Pending Interrupt Register (Read-only) - Register 4

The Pending Interrupt Register contains information that identifies events that generate interrupts. The assertion of any bit in this register asserts an output pin, `MSG_INT` or `YF_INT` (three clock cycles). Writing to the most significant four bits of this register generates a `YF_INT`.

Bit Number	Mnemonic	Description
15	DMAF	DMA Fail Interrupt. Once the <code>SμMMIT</code> has issued the <code>DMAR</code> signal, an internal timer is started. If all DMA activity has not been completed, the interrupt is generated (if not masked). In the SMT mode, the <code>YF_INT</code> interrupt is generated, current command processing will end, and the SMT will remain on-line.
14-13	N/A	Not Applicable.
12	BITF	BIT Fail Interrupt. Assertion of this bit indicates a BIT failure. Interrogate the BIT Word Register to determine the specific failure. <code>YF_INT</code> interrupt generated (if not masked), operation continues.
11	MERR	Message Error Interrupt. This bit is set if a message error occurs. The SMT can detect Manchester, sync-field, word count, 1553 word parity, bit count, and protocol errors. This bit will be set and interrupt generated after message processing is complete. <code>MSG_INT</code> interrupt generated (if not masked).
10-1	N/A	Not Applicable.
0	MBC	Monitor Block Counter Interrupt. This bit is set if the SMT's monitor block counter reaches zero (transition from 1 to 0). It should be noted that the SMT does not discriminate between error-free messages and those messages with errors. <code>MSG_INT</code> interrupt generated (if not masked).

Note: The user must read or write a `SμMMIT` register after reading the Pending Register to invoke the automatic clear of the Pending Interrupt Register. For example, a Subaddress Access interrupt results in a Pending Interrupt Register of `040016`. A read of the Pending Interrupt Register returns a value of `040016`. A subsequent read of the Interrupt Mask Register (i.e., Register `316`), followed by a Pending Interrupt Register read returns a value of `000016`. The intervening read of the Interrupt Mask Register clears of the Pending Interrupt Register at the end of the Interrupt Mask Register read.

4.1.6 Interrupt Log List Pointer Register (Read/Write) - Register 5

This register indicates the starting address of the Interrupt Log List. The Interrupt Log List is a 32-word ring-buffer that contains information pertinent to the service of interrupts. The `SμMMIT` architecture requires the location of the Interrupt Log List on a 32-word boundary. The most significant 11 bits of this register designate the location of the Interrupt Log List within a 32K memory space. Initialize the lower five bits of this register to a logic zero. The `SμMMIT` controls the lower five bits to implement the ring-buffer architecture. The host or subsystem reads this register to determine the location and number of interrupts within the Interrupt Log List (least significant five bits).

Bit Number	Mnemonic	Description
15-0	INTA(15:0)	Interrupt Log List Pointer Bits. These bits indicate the starting location of the Interrupt Log List.

4.1.7 BIT Word Register (Read/Write)- Register 6

This register contains information on the current health of the SMT. The lower eight bits of this register are user-defined.

Bit Number	Mnemonic	Description
15	DMAF	DMA Fail. This bit is set if all DMA activity has not been completed between the time DMAR asserts and when the timer decrements to zero. The DMA activity includes DMAR to DMAG and all wait states. In the event of a DMA failure, current message processing terminates; monitor terminal waits for next 1553 message.
14-13	N/A	Not Applicable.
12	BITF	BIT Fail. Assertion of this bit indicates a BIT failure. Interrogate bits 11 through 8 to determine the specific failure.
11	CHAF	Channel A Fail. Assertion of this bit indicates a BIT test failure in Channel A.
10	CHBF	Channel B Fail. Assertion of this bit indicates a BIT test failure in Channel B.
9	MSBF	Memory Test Fail. Most significant memory byte failure (SμMMIT XT). User-Defined Bits (SμMMIT & SμMMIT LX/DX).
8	LSBF	Memory Test Fail. Least significant memory byte failure (SμMMIT XT). User-Defined Bits (SμMMIT & SμMMIT LX/DX).
7-0	UDB(7:0)	User-Defined Bits.

4.1.8 Time-Tag Register (Read/Write) - Register 7

This register reflects the state of a 16-bit free running ring counter. This counter will remain a free running counter as long as the device is not in MRST or in a software reset state. The resolution of this counter is user-defined via input TCLK or fixed at 64μs/bit. The Time-Tag counter begins operation on the rising edge to MRST.

Bit Number	Mnemonic	Description
15-0	TT(15:0)	Time-Tag Counter Bits. These bits indicate the state of the 16-bit internal counter.

4.1.9 Initial Monitor Block Pointer Register (Read/Write) - Register 11

This register contains the starting location of the monitor blocks.

Note: It is recommended that this register not be changed while the SMT is active (i.e., Register 1, bit 3 = 1).

Bit Number	Mnemonic	Description
15-0	MBA(15:0)	Initial Monitor Block Address. These bits indicate the starting location of the monitor block.

4.1.10 Initial Monitor Data Pointer Register (Read/Write) - Register 12

This register contains the starting location of the monitor data.

Note: It is recommended that this register not be changed while the SMT is active (i.e., Register 1, bit 3 = 1).

Bit Number	Mnemonic	Description
15-0	MDA(15:0)	Initial Monitor Data Address. These bits indicate the starting location of the monitor data.

4.1.11 Monitor Block Counter Register (Read/Write) - Register 13

This register contains the number of monitor blocks the user wishes to log. After execution begins, this register automatically decrements as commands are logged. When this register is decremented from one to zero, an interrupt will be generated, if enabled. The SMT will start over at the initial pointers as identified in Registers 11 and 12.

Note: It is recommended that this register not be changed while the SMT is active (i.e., Register 1, bit 3 = 1).

Bit Number	Mnemonic	Description
15-0	MBC(15:0)	Monitor Block Count. These bits indicate the number of monitor blocks to log.

4.1.12 Monitor Filter Register (Read/Write) - Register 14

This register determines which RTs (RT 31 through RT 16) the SMT will monitor.

Bit Number	Mnemonic	Description
15-0	MF(31:16)	Monitor Filter. These bits determine which RT to monitor.

4.1.13 Monitor Filter Register (Read/Write) - Register 15

This register determines which RTs (RT 15 through RT 0) the SMT will monitor.

Bit Number	Mnemonic	Description
15-0	MF(15:0)	Monitor Filter. These bits determine which RT to monitor.

4.2 SMT Architecture

To meet the MIL-STD-1553 monitor requirements, the SMT utilizes a monitor block architecture that takes advantage of both internal registers and external memory. The monitor block, which is located in external contiguous memory, requires eight locations for each message. These eight locations include a message information word, two command word locations, a data pointer, two status word locations, a time-tag location, and an unused location.

The host, or ROM for autonomous operation, must initialize the starting locations of the monitor block, the Data Pointer, Block Counter, and the Interrupt Log Pointer. From then on, the SMT will build a monitor block for each message it receives over the 1553 bus. Figure 11 shows a diagram of the monitor block followed by a description of each location associated with the monitor block.

The first memory location of each monitor block contains the message information word. Each message information word contains the opcode, retry number, bus definition, RT-RT messages, and the message information.

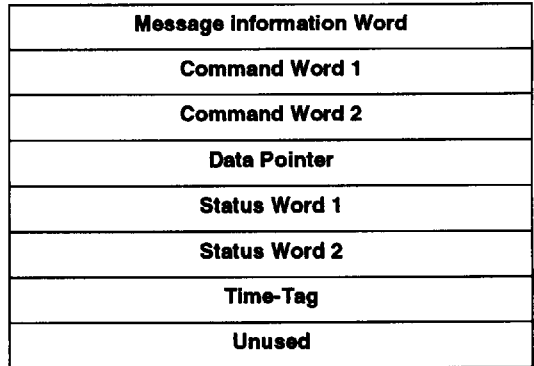
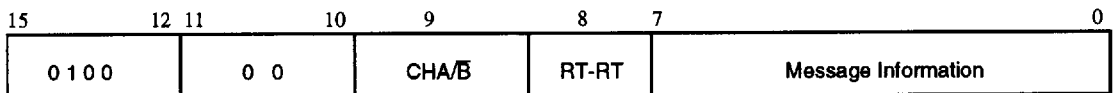

Figure 12. Monitor Block Diagram



4.2.1 Message Information Word

Bit Number	Description
15-12	Default. With the monitor block architecture resembling the SBC Command Block architecture, these bits default to a "0100" state (which is the Execute and Continue opcode) in case the monitor must switch to the BC mode of operation.
11-10	Default. With the monitor block architecture resembling the SBC, these bits default to a "00" state. If the monitor must switch to the BC, the retries will be set at four per message.
9	Channel A/B. This bit defines on which of the two buses the command was received. (Logic 1 = Bus A, Logic 0 = Bus B).
8	RT-RT Transfer. This bit defines whether or not the message associated with this monitor block was an RT-RT transfer and whether the SMT saved the second command word. This bit will be set only if the SMT is instructed to monitor the Receive RT.
7-0	Message Information. These bits define the conditions of the message received by the SMT for that particular monitor block. Each of the message information bits is defined in the following section.

4.2.1.1 Message Information Bits

Message information bits are provided as a means to supply more data on the message. In an RT-RT transfer, the information applies to the complete message. Each message information bit is defined below.

Bit Number	Description
7	Message Error. This bit will be set if the monitor detects an error in either the command word, data words, or the RT's status.
6	Mode Code without Data. This bit will be set if the monitor detects that the command being processed is a mode code without data words.
5	Broadcast. This bit will be set if the monitor detects that the command being processed is a broadcast message.
4	Reserved.
3	Time-out Error. This bit will be set if the SRT did not receive the proper number of data words, e.g., the number of data words received was less than the word count specified in the command word.
2	Overrun Error. This bit will be set if the SRT received a word when none were expected or the number of data words received was greater than expected.
1	Parity Error. This bit will be set if a parity error has occurred on the data words or the RT's status word.
0	Manchester Error. This bit will be set if a Manchester error has occurred on either the data words or the RT's status word.

4.2.2 Command Words

The next two locations in the SMT monitor block are for command words. In non-RT-RT 1553 messages, only the first command word will be stored. However, in an RT-RT transfer, the first command word is the Receive Command and the second command word is the Transmit Command.

4.2.3 Data Pointer

The fourth location in the SMT monitor block is the data pointer. This pointer points to the first memory location to store the data words associated with the message for this block. Note that the data associated with each individual message will be stored contiguously. This data structure allows the SMT to store the specified number of data words. (Note: In an RT-RT transfer, the SMT uses the data pointer as the location in memory to store the transmitting data in the transfer.)

4.2.4 Status Words

The next two locations in the SMT monitor block are for status words. As the RT responds to the BC's command, the corresponding status word will be stored in Status Word 1. However, in an RT-RT transfer, the first status word will be the status of the Transmitting RT while the second status word will be the status of the Receiving RT.

4.2.5 Time-Tag

The seventh location in the SMT monitor block is the time-tag associated with the message. The time-tag is stored into this location at the end of message processing (i.e., captured after the command is validated).

4.2.6 Unused

The last location in the SMT monitor block is unused.

4.3 Monitor Block Chaining

The host determines the first monitor block by setting the start address in the initial monitor block Pointer Register (Register 11). Figure 13 shows the SMT monitor blocks as the blocks execute in a contiguous fashion (monitor block count = 5).

4.4 Memory Architecture

Figure 14 shows the monitor blocks, data locations, and the Interrupt Log List as separate entities within memory. The configuration shows that the first block of memory is allocated for the monitor blocks. Notice that Register 11 points to the initial monitor block location, Register 12 points to the initial Data location, Register 5 points to the Interrupt Log, and Register 13 contains the monitor block count. After execution begins, the SMT will build command blocks and store data words until the count reaches zero. When the count reaches zero, the SMT will simply wrap back to the initial values and start again.

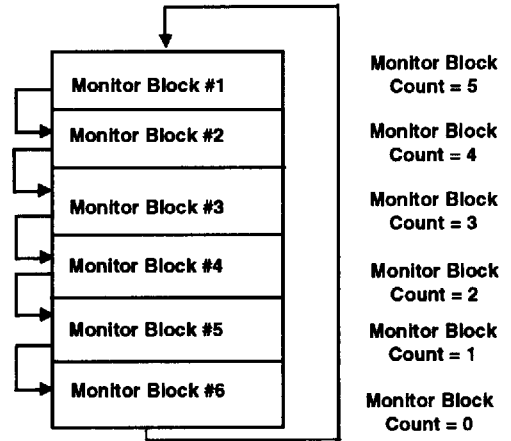

Figure 13. Monitor Block Structuring

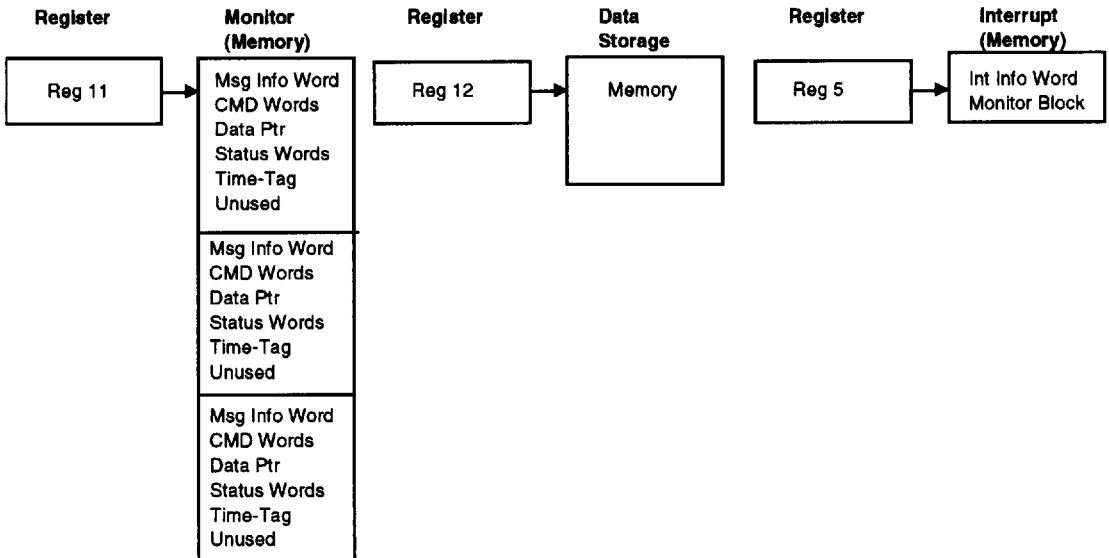

Figure 14. Memory Architecture for Monitor Mode

4.5 Message Processing

To process messages, the SMT uses data supplied in the internal registers along with external memory. The SMT uses seven external memory locations for each message called a monitor block. The monitor block is updated at the end of command processing. The following paragraphs discuss the command block in detail.

The μ MMIT features two different modes of transferring data to RAM: Buffer and Non-Buffer. The user selects the Buffer or Non-Buffer transfer mode by setting the BUFR bit (bit 6) in the Control Register. See sections 9.1.5 or 9.2.3 for additional information.

The host or subsystem controlling the SMT allocates memory spaces for each monitor block. The top of the monitor blocks can reside at any address location. Initialized by the host, the SMT is linked to the monitor block via the initial monitor block Pointer Register and the Monitor Block Counter Register contents. Each monitor block contains a Message Information Word, Command Word 1, Command Word 2, Data Pointer, Status Word 1, Status Word 2, and Time-Tag. Refer to sections 4.2.1 - 4.2.6 for a full description of each location.

The Message Information word allows the SMT to tell the host or subsystem on which bus the command was received, whether the message was an RT-RT transfer, and conditions associated with the message. The SMT also stores each command word associated with the message into the appropriate location. For normal 1553 commands, only the first command word location will contain data. For RT-RT commands, the second command word location will contain data, and bit 8 in the Message Information word will be set.

For each command, the Data Pointer determines where to store data words. The SMT stores data sequentially from the top memory location. The SMT also stores each status word associated with the message into the appropriate location. For normal 1553 commands, only the first status word location will contain data. For RT-RT commands, the second status word location will contain data.

The SMT begins monitoring after Control Register bit 15=1 (i.e., assertion of STEX).

After reception, the SMT begins post-processing. The SMT performs a DMA burst during post-processing. An optional interrupt log entry is performed after a monitor block is entered. Monitor Time-Out:

$$\begin{aligned} \text{MIL-STD-1553A} &= 9\mu\text{s} \\ \text{MIL-STD-1553B} &= 15\mu\text{s} \end{aligned}$$

See section 5, Enhanced μ MMIT Family Operation for additional information.

4.6 Remote Terminal/Monitor Terminal Operation

For applications that require simultaneous Remote Terminal and Monitor Terminal operations, the μ MMIT should be configured as both a remote terminal (SRT) and monitor terminal (SMT). This feature allows the SRT to communicate on the bus for one specific address and the SMT to monitor the bus for other specific addresses. Configuration as both SMT and SRT precludes the μ MMIT from monitoring its own remote terminal address.

When the μ MMIT is configured as both SRT and SMT, the SRT has priority over the SMT. For example, commands to the SRT will always take priority over commands for the SMT. The examples below describe what happens if the SRT is defined as terminal address 1 and the SMT is to monitor terminal address 12.

Example 1:

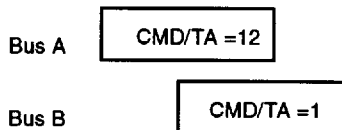

In this example, the SMT will decode the first command on bus A, realize the message is for terminal address 12, and start monitoring the message. However, as soon as the SRT realizes the second command on bus B is to terminal address 1, the SRT will take priority and begin SRT message processing.

Example 2:

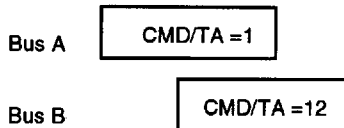

In example 2, the SRT will decode the first command on bus A, realize the message is for terminal address 1, and start message processing. As the message on bus B is received, the SμMMIT will realize it is to terminal address 12, but since the SRT has priority the SMT will not switch to the monitor mode.

The above examples also apply to an RT-RT message. For example, if the first command in an RT-RT transfer matches the terminal address of the SRT, the entire message will be processed by the SRT (Message 1). However, if the first command in an RT-RT transfer matches the terminal address of the SMT and the second command matches the terminal address of the SRT, the SRT will take priority and process the message (Message 2). Below is an RT-RT message example.

Message 1	CMD/TA =1	CMD/TA =12
Message 2	CMD/TA =12	CMD/TA =1

4.7 MIL-STD-1553A Operation

To maximize flexibility, the SμMMIT has been designed to operate in many different systems which use various protocols. Specifically, two of the protocols that the SμMMIT may be interfaced to are MIL-STD-1553A and MIL-STD-1553B. To meet these protocols, the SμMMIT may be configured through an external pin or through control register bits (depending on the state of the LOCK pin).

Table 6. MIL-STD-1553A Operation

A/B STD (pin)	RESULT
0	1553B response, 1553B standard
1	1553A response, 1553A standard

When configured as a MIL-STD-1553A monitor, the SμMMIT will operate as follows:

- Looks for the RT response within 9μs (see section 5, Enhanced SμMMIT Family Operation);
- Defines all mode codes without data;
- Defines subaddress 00000 as a mode code.

5.0 ENHANCED SμMMIT FAMILY OPERATION

The following describes the Enhanced SμMMIT features.

5.1 Message Time-out

Programmable bus controller and monitor time-out feature allows for the implementation of extended buses. Bit 9 of the Control Register determines the remote terminal no response time period. During MIL-STD-1553B operation, the programmable time-out occurs at either 14μs or 30μs. In MIL-STD-1553A mode, time-out occurs at either 9μs or 21μs. See Figure 15.

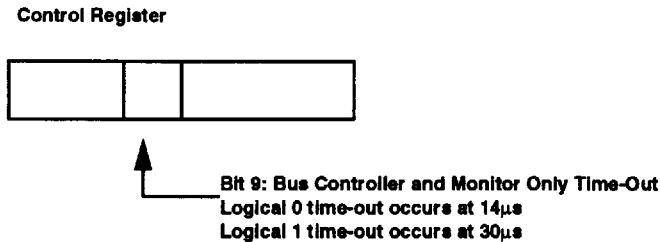

Figure 15. Programmable Bus Controller Time-Out

5.2 DMA Time-out

DMA time-out, in the bus controller mode of operation, is 16μs (t_b , t_d). The SμMMIT architecture times all DMA cycles to ensure that memory access timing supports message processing. Excessive memory access delays result in a DMA time-out condition. In the event of DMA time-out, the SμMMIT ceases message processing and generates an interrupt if enabled. The SμMMIT and SμMMIT LX/DX specify the DMA time-out period per AC Electrical Characteristic t_b . The SμMMIT XT specifies the DMA time-out per AC Electrical Characteristic t_a . See figure 38 for t_b and figure 50 for t_a .

5.3 Circular Buffers

The SμMMIT family circular buffer simplifies the software service of remote terminals implementing bulk or periodic data transfers. The Enhanced SμMMIT architecture allows the user to select one of two circular buffer modes. The user selects the preferred mode, at start-up, by writing to Control Register bits 7 and 8. The Control Register bits allow for the decode of three unique modes. Table 7 reviews mode selections.

Table 7. Enhanced Mode of Operation

Mode Number	Bit 7	Bit 8
0	0	0
1	0	1
X	1	0
2	1	1

5.3.1 Mode Number 0

Remote Terminal Index or Ping-Pong Operation, non-Enhanced SμMMIT, the user programs bits 7 and 8 to logical zero. Operation is per sections 2.2 and 2.3 (default state).

5.3.2 Mode Number 1

Remote Terminal Buffer 1, Enhanced SμMMIT operation, the user programs bit 7 to 0 and bit 8 to 1. The SμMMIT merges transmit or receive data into a circular buffer along with message information. For each valid receive message, the SμMMIT enters a message information word, time-tag word, and data word(s) into a unique receive circular buffer. For each valid transmit message, the SμMMIT enters a message information word and time-tag word into reserved memory locations within the transmit circular buffer. The SμMMIT automatically controls the wrap around of circular buffers.

Two pointers define circular buffer length: top of buffer and bottom of buffer. User specifies the top of buffer (i.e., top address (TA_{16})) by writing a value into the second word of a unique mode code or subaddress descriptor block. The user defines the bottom of the buffer (i.e., bottom address (BA_{16})) by writing to the fourth word of that unique descriptor block. Both the TA_{16} and BA_{16} remain static during message pro-

cessing. The third word in the descriptor block identifies the current address (i.e., last accessed address plus one). The circular buffer wraps to the top address after completing a message that results in CA_{16} being greater than or equal to BA_{16} . If CA_{16} increments past BA_{16} during intra-message processing, the μ MMIT will access memory (read or write) address locations past BA_{16} . Delimit all circular buffer boundaries with at least 34 address locations.

Each subaddress and mode code, both transmit and receive, has a unique circular buffer assignment. The μ MMIT decodes the command word T/R bit, subaddress/mode field, and word count/mode code field to select a unique descriptor block which contains TA_{16} , CA_{16} , and BA_{16} .

For receive messages, the μ MMIT stores the message information word into address location CA_{16} , the time-tag word into $CA_{16} + 1_{16}$, and the data into the next "N₁₆" locations starting at address $CA_{16} + 2_{16}$. For each transmit command, the μ MMIT stores the message information word into address location CA_{16} and time-tag word into location $CA_{16} + 1_{16}$. Retrieval of data for transmission starts at address location $CA_{16} + 2_{16}$. When entering multiple transmit command data packets into the circular buffer, delimit each data packet with two reserved memory locations. The μ MMIT enters the message information word and time-tag word into the delimiting memory locations.

5.3.3 Mode Number 2

Circular Buffer 2, enhanced μ MMIT operation, the user programs Control Register bit 7 to 1 and bit 8 to 1. The μ MMIT separates message data and message information into unique circular buffers. The separation of data from message information simplifies the software that loads and unloads data from the buffers. Each subaddress and mode code, both transmit and receive, has a unique pair of circular buffers. The μ MMIT decodes the command word T/R bit, subaddress/mode field, and word count/mode code field to select a unique descriptor block which contains TA_{16} , CA_{16} , and Message Information Buffer (MIB).

Control the wrap-around of both the data and message circular by specifying the number of messages before wrap-around occurs. The second word entered into the descriptor block determines the top of the data buffer (TA_{16}). The third word in the descriptor block identifies the current position (CA_{16}) in the buffer (i.e., last accessed address plus one). The fourth word in the descriptor block identifies the MIB's starting location and current position. The MIB contains Time-Tag and Message Information words for each message transacted on the bus. The data buffer and message information word buffer wrap around after processing a pre-determined number of

messages. Each subaddress and mode code, both transmit and receive, has a unique data buffer and MIB assignment.

5.4 Ping-Pong Handshake

The Enhanced μ MMIT provides a software handshake which indicates the enable and disable of buffer ping-pong operation. During remote terminal operation, the μ MMIT asynchronous ping-pongs between two subaddress or mode code data buffers. To perform buffer service, the application software must freeze the remote terminal's access to a single buffer. The μ MMIT's ping-pong enable/disable handshake allows the application software to asynchronously freeze (i.e., disable ping-pong operation) the remote terminal to a single buffer.

5.5 Circular Buffer Mode #1

To implement Circular Buffer 1's architecture, the four word descriptor block and Control Register are different than in the mode #0. Bits 15 through 8 of the Control Word are don't care. The second word of the descriptor block defines the buffer's starting or top address (TA_{16}). The TA pointer remains static during message processing. The fourth entry into the descriptor block identifies the buffer's bottom address (i.e., BA_{16}) and also remains static during message processing. The third descriptor block words represent the current address (i.e., CA_{16}) in the buffer and is dynamic. If the μ MMIT observes no message error conditions, the CA_{16} pointer updates at the end of message processing. The application software reads the dynamic CA_{16} pointer to determine the current bottom of the buffer.

First, a review of receive message processing. The μ MMIT begins all message processing by reading a unique descriptor block after reception and validation of a subaddress or mode code command word. The μ MMIT internally increments the CA_{16} pointer to store the receive data word(s). After message processing completes, the μ MMIT stores the message information word and time-tag word into the circular buffer preceding the message data. At the end of message processing, the μ MMIT updates CA_{16} (if no errors detected). For CA_{16} larger than BA_{16} storage of the next message begins at the address location pointed to by the TA_{16} pointer, and CA_{16} is made equal to TA_{16} . If CA_{16} is less than BA_{16} , CA_{16} points to the next available memory location in the buffer (i.e., $CA_{16} + 1$).

For transmit commands, the μ MMIT begins transmission of data from memory location $CA_{16} + 2_{16}$. Reserve the first two locations for the message information word and time-tag word. After message processing completes, the μ MMIT enters the message information word and time-tag word into the circular buffer. At the end of message processing, the μ MMIT updates CA_{16} (if no errors detected). For CA_{16}

larger than BA_{16} , storage of the next message begins at the address location pointed to by the TA_{16} pointer, and CA_{16} is made to equal TA_{16} . If CA_{16} is less than BA_{16} , CA_{16} points to the next available memory location in the buffer (i.e. $CA_{16} + 1$).

In this mode of operation bits, $INDX$, NII and A/B of the Descriptor Control Word and the $PPEN$ bit of the Control Register are don't care. Message information word bit 5 reflects the reception of broadcast message via the BRD bit.

The Σ MMIT generates a circular buffer empty/full interrupt when the buffer reaches the end (i.e., CA_{16} greater than BA_{16}) and begins a new message at the top of the buffer. Bit 8 of the Mask Register and bit 7 of the Descriptor Control Word mask enables the generation of the Full/Empty interrupt. On the occurrence of either interrupt, the MSG_INT output asserts. Figure 16 describes the relationship between TA_{16} , BA_{16} , and CA_{16} .

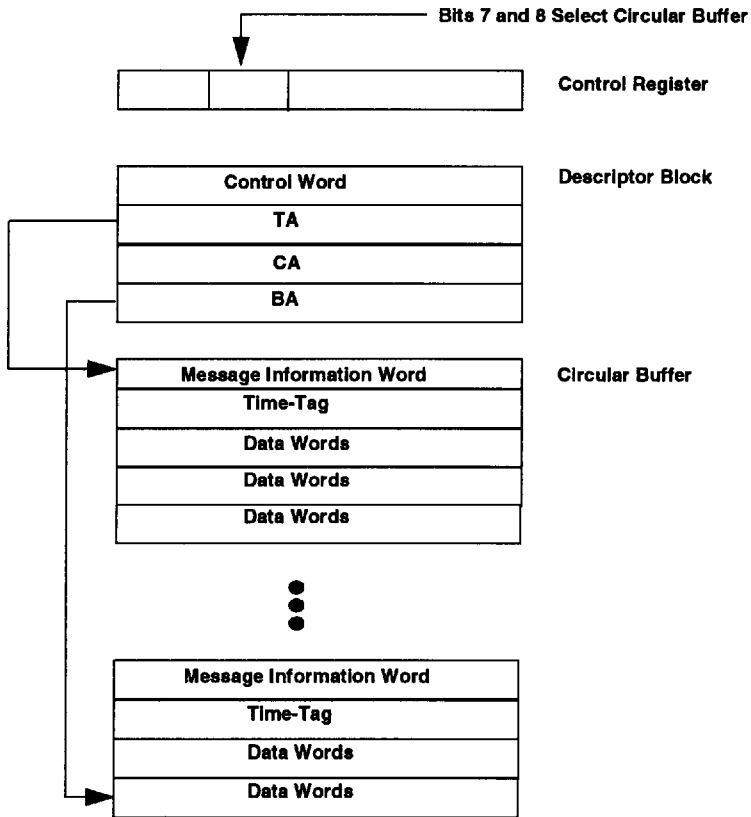

Figure 16. Circular Buffer Mode #1

5.6 Circular Buffer Mode #2

To implement Circular Buffer 2's architecture, the descriptor block and Control Register are different than in mode #0. Bits 15 through 8 of the Control Word specify the Message Information Buffer (MIB) length; the maximum MIB length is 256. Table 8 shows how the Control Word's most significant bits select the depth of the MIB. The Control Words eight most significant bits remain static during message processing.

The second word of the descriptor block defines the top address (TA_{16}) of the data circular buffer. The TA_{16} pointer remains static during message processing. The third descriptor word identifies the current address (i.e., CA_{16}) of the data circular buffer. The application software reads the dynamic CA_{16} pointer to determine the current address of the data buffer. The $S\mu MMIT$ increments the CA_{16} pointer, at the end of message processing, until the MIB buffer is full. When the MIB wraps around, the $S\mu MMIT$ loads the CA_{16} pointer with the TA_{16} pointer.

The fourth word in the descriptor block defines the top or base address of the Message Information Buffer (i.e., MIB) and the current MIB address (i.e., offset from base address). The $S\mu MMIT$ enters the message information word and time-tag word into the MIB, for each message, until the end of the MIB is reached. When the MIB reaches the end, the next message's message information word and time-tag word is entered at the top of the MIB. The MIB pointer is a semi-static pointer. The $S\mu MMIT$ updates the current address field at the end of message processing. The base address field remains static.

Application software reads the current MIB address to determine the number of messages processed since last service. The variable length MIB requires the base address and current address field to also vary in length. Table 8 displays the relationship between Control Word bits 15 through 8, MIB length, MIB base and current address fields. The current address field of the MIB must begin on an even boundary.

First is a review of receive message processing. The $S\mu MMIT$ begins all message processing by reading the descriptor block of the subaddress or mode code command received (i.e., ControlWord, TA_{16} , CA_{16} , and MIB). The $S\mu MMIT$ begins storage of data word(s) starting at the location contained in the CA_{16} pointer.

The $S\mu MMIT$ automatically updates the CA_{16} pointer internally as message processing progresses. After receiving the correct number of data words, the $S\mu MMIT$ stores the message information word and time-tag word into the MIB. At the end of message processing, the $S\mu MMIT$ updates CA_{16} and the MIB Current Address Field (CAF). If CAF equals the specified MIB length, CA_{16} is updated to TA_{16} and the MIB CAF is reset to zero. If CAF is less than the specified MIB length, CA_{16} and MIB CAF point to the next available memory location in each buffer. Control Word bits 15 to 8 specify the MIB length.

For transmit commands, the $S\mu MMIT$ begins transmission of data from memory location CA_{16} . After message processing completes, the $S\mu MMIT$ enters the message information word and time-tag word into the MIB. At the end of message processing, the $S\mu MMIT$ updates CA_{16} and the MIB CAF. If CAF equals the specified MIB length, CA_{16} is updated to TA_{16} and the MIB CAF is reset to zero. If CAF is less than the specified MIB length, CA_{16} and MIB CAF point to the next available memory location in each buffer.

In this mode of operation bits, $INDX$, NII and A/B of the descriptor control word and the $PPEN$ bit of the Command Register are don't care. The BRD bit is added to the Message Information Word bit 5.

The $S\mu MMIT$ generates a circular buffer empty/full interrupt when the MIB reaches the end and begins a new message at the top of the buffer. Bit 8 of the Mask Register and bit 7 of the descriptor Control Word mask and enable the generation of the Full/Empty interrupt. On the occurrence of either interrupt, the MSG_INT output asserts. Figure 17 describes the relationship between TA_{16} , CA_{16} , and MIB.

Table 8. Control Word and MIB Length

Control Word Bits (15:8)	Length of MIB	MIB Pointer Base and CAF [Base Address][CAF] = Memory Location Bit Positions
		15 - 14 - 13 - 12 - 11 - 10 - 9 - 8 - 7 - 6 - 5 - 4 - 3 - 2 - 1 - 0
FF	128	[-----Base Address -----][-----CAF-----]
7F	64	[-----Base Address-----][-----CAF-----]
3F	32	[-----Base Address-----][-----CAF-----]
1F	16	[-----Base Address-----][-----CAF-----]
0F	8	[-----Base Address-----][-----CAF-----]
07	4	[-----Base Address-----][-----CAF-----]
03	2	[-----Base Address-----][-----CAF-----]
01	1	[-----Base Address-----][CAF]

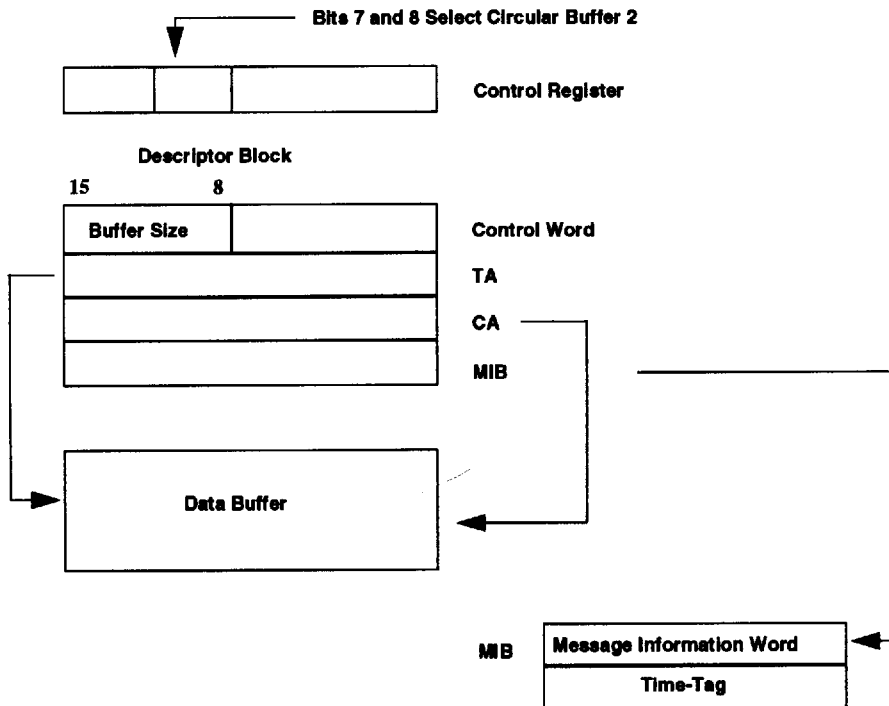

Figure 17. Circular Buffer Mode #2

5.7 Ping-Pong Enable/Disable Handshake

Prior to starting remote terminal operation, enable the buffer ping-pong feature by writing a logical 1 to bit 2 of the Control Register. During ping-pong operation, the remote terminal ping-pongs between the two data buffers, for each subaddress or mode code, on a message by message basis. Each unique MIL-STD-1553 subaddress and mode code is assigned two data buffer locations (A and B). The remote terminal retrieves data from a buffer or stores data into a buffer depending on the message type (i.e., transmit or receive command). During ping-pong operation, the remote terminal determines the active subaddress or mode code buffer at the beginning of message processing, the remote terminal complements bit 2 of the Descriptor Control Word to access the alternate buffer on the following message (i.e., ping-pong). See Figure 18 for ping-pong buffer flow chart.

To off-load or load the subaddress and mode code buffers without collisions (e.g., remote terminal writing and application software reading the same buffer), the application software must disable ping-pong operation (i.e., freeze the remote terminal access to a single buffer, either A or B). Disabling ping-pong operation allows the application software to off-load or load the alternate buffer while the remote terminal continues to use the active buffer. To implement this architecture, ping-pong operation must enable and disable asynchronously via software with feedback to indicate that buffer ping-ponging is truly disabled. Second, unique subaddress and mode code flags indicate which buffer is active. Each unique subaddress and mode code is assigned a flag which indicates the active buffer.

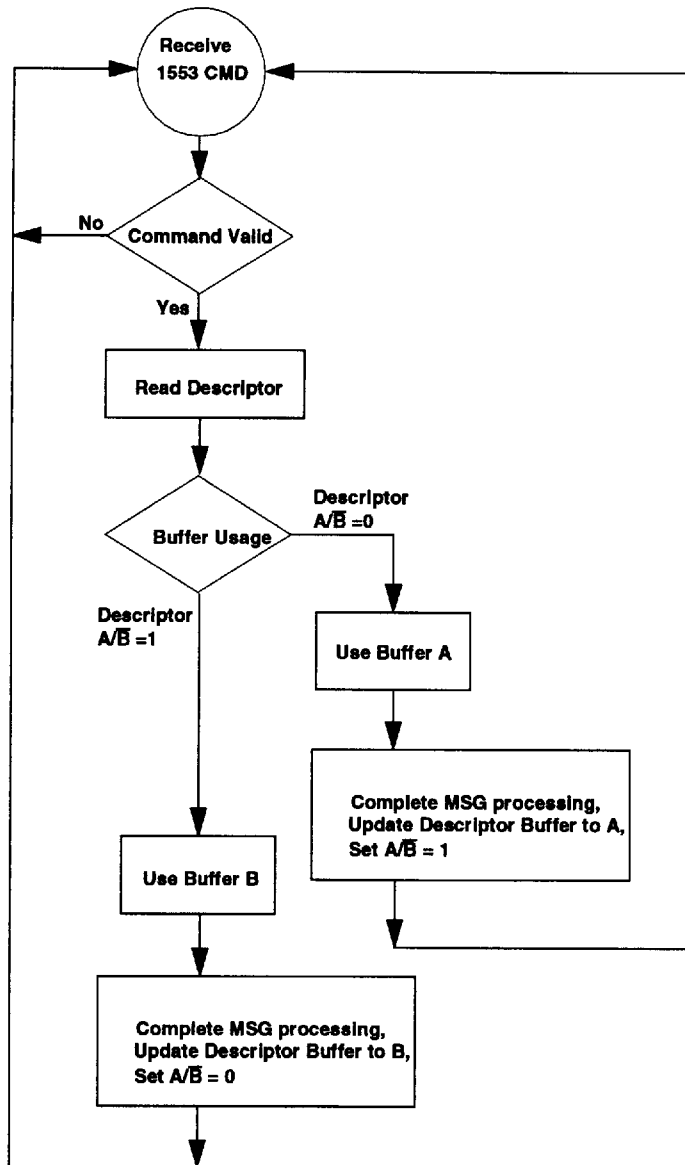

Figure 18. Ping-Pong Buffer Flow Chart

To begin the process of off-loading or loading the remote terminal's subaddress and/or mode code buffers, when using the ping-pong feature, the application software performs the following sequence: disables ping-pong operation, determines the active buffer, services the alternate buffer, enables ping-pong operation.

The application software disables ping-pong operation by writing a logical zero to Control Register bit 2. The disable of ping-pong operation is acknowledged by bit 9 of the Control Register. Bit 9 of the Control Register acknowledges the ping-pong disable by transitioning from a logical one to a logical zero. The application software interrogates bit 2 of each Descriptor Control Word to determine the active buffer on a subaddress or mode code basis. If bit 2 is a logical zero, the remote terminal uses Buffer A and the application software off-loads or loads Buffer B. If bit 2 is a logical one, the remote terminal uses Buffer B and the application software off-loads or loads Buffer A. Figure 19 displays Control Register bits for ping-pong enable/disable and acknowledge.

The application software enables ping-pong operation by writing a logical one to Control Register bit 2. The enable of ping-pong operation is acknowledged by bit 9 of the Control Register. Bit 9 of the Control Register acknowledges the ping-pong enable by transitioning from a logical zero to a logical one.

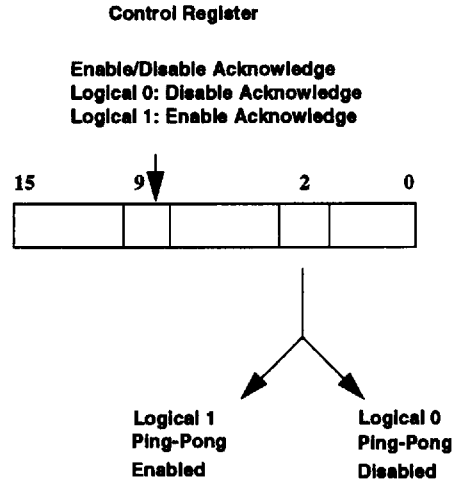

Figure 19. Ping-Pong Handshake

6.0 INTERRUPT ARCHITECTURE

6.1 μ MMIT & μ MMIT LX/DX

The μ MMIT & μ MMIT LX/DX interrupt architecture involves three internal registers, an Interrupt Log List and two interrupt outputs. The three internal registers include a Pending Interrupt Register, Interrupt Mask Register, and Interrupt Log List Register. See figure 20 and register descriptions for additional information. The Pending Interrupt Register contains information that identifies the events generating the interrupts. The Interrupt Mask Register allows the user to mask or disable the generation of interrupts. The Interrupt Log List Register contains the base address of a 32-word interrupt ring buffer. Two interrupt outputs signal the occurrence of an interrupt event. The interrupt architecture differentiates interrupts as either a hardware interrupt (YF_INT) or message interrupt (MSG_INT).

The YF_INT interrupt bits are stored in the upper four bits of the Pending Interrupt Register and the BIT Word register. These four interrupts must be processed as they occur since they are not stored in the Interrupt Log List.

Note: If the pending interrupt register is not cleared after the first YF_INT , the setting of other YF_INT bits will not result in a YF_INT pulse.

The MSG_INT bits are stored in the Pending Interrupt Register. These interrupts are entered into the Interrupt Log List, if the Interrupt Log List is enabled.

The μ MMIT & μ MMIT LX/DX interrupt architecture also allows the entry of 16 interrupts into a 32-word ring buffer. The μ MMIT & μ MMIT LX/DX automatically handles the interrupt logging overhead. Each interrupt generates two words of information to assist the host or subsystem when processing interrupts. The Interrupt Identification Word (IIW) identifies the type(s) of interrupt that occurred. The Interrupt Address Word (IAW) identifies the interrupt source via a 16-bit address.

The μ MMIT & μ MMIT LX/DX asserts one of two outputs, MSG_INT or YF_INT , to signal the host or subsystem that an interrupt event occurred. The YF_INT may occur at any time.

The MSG_INT asserts after the final $DMACK$ negation associated with the storage of the IIW and IAW.

6.1.1 Interrupt Identification Word (IIW)

The Interrupt Identification Word (IIW) is a 16-bit word identifying the interrupt type(s). The format is similar to the Pending Interrupt Register. The host or subsystem reads the IIW to determine which interrupt event occurred. The bit description for the IIW is provided in Table 9.

6.1.2 Interrupt Address Word (IAW)

The Interrupt Address Word (IAW) is a 16-bit word that identifies the interrupt source. Depending on the mode of operation (i.e., SRT, SBC, or SMT), the IAW has different meanings. In the SRT mode of operation, the IAW identifies the subaddress or mode code descriptor that generated the interrupt. For the SBC mode of operation, the IAW points to the command block addressed when the interrupt occurred. In the SMT mode of operation, the IAW marks the monitor counter count when the interrupt occurred. The host uses the IAW with the Initial Monitor Command Block Pointer Register to determine the monitor command block that generates the interrupt.

When the SMT is operating concurrently with the SRT, the host must determine if the IAW contains information for the SRT or SMT. The determination is made by comparing the contents of the IAW base address with the descriptor base address. If a match occurs, then the IAW contains a subaddress or mode code identifier. If no match occurs, the IAW contains monitor counter information.

6.1.3 Interrupt Log List Address

The interrupt log list resides in a 32-word ring buffer. The host or subsystem defines the location buffer, within a 64K x 16 memory space, via the Interrupt Log List Register (Register 5). Restrict the ring buffer address to a 32-word boundary.

During initialization the host or subsystem writes a value to the Interrupt Log List Pointer Register. Initialize the least significant five bits to a logic zero. The most significant 11 bits determine the base address of the buffer. The μ MMIT & μ MMIT LX/DX increments the ring buffer pointer on the

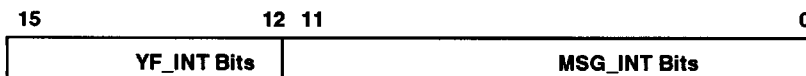

Figure 20. Pending Interrupt and Mask Register

occurrence of the first interrupt, storing the IIW and IAW at locations 00000 and 00001 respectively. The SμMMIT & SμMMIT LX/DX logs ensuing interrupts sequentially into the ring buffer until interrupt number 16 occurs. The SμMMIT & SμMMIT LX/DX enters interrupt 16's IIW in buffer location 11110 and the IAW at location 11111. The ring wraps-around at a value of 11111.

The SμMMIT & SμMMIT LX/DX increments the ring buffer pointer as interrupts occur. The least significant five bits of the Interrupt Log List Pointer Register reflect the ring buffer pointer value. Figure 21 shows the ring buffer architecture.

The host or subsystem reads ring buffer pointer value to determine the number of interrupts that have occurred. By extracting the least significant five bits from the Interrupt Log List Register and logically shifting the data once to the right, the host or subsystem determines the number of interrupt events.

Table 9. Interrupt Information Word

Bit Number	Mnemonic	Description
15-12	N/A	Not Applicable.
11	MERR	Message Error Interrupt (All modes).
10	SUBAD	Subaddress Accessed Interrupt (SRT).
9	BDRCV	Broadcast Command Received Interrupt (SRT).
8	IXEQ0	Index Equal Zero Interrupt (SRT).
7	ILCMD	Illegal Command Interrupt (SRT).
6	N/A	Not Applicable.
5	EOL	End of List (SBC).
4	ILLCMD	Illogical Command (SBC).
3	ILLOP	Illogical Opcode (SBC).
2	RTF	Retry Fail (SBC).
1	CBA	Command Block Accessed (SBC).
0	MBC	Monitor Block Count Equal Zero (SMT).

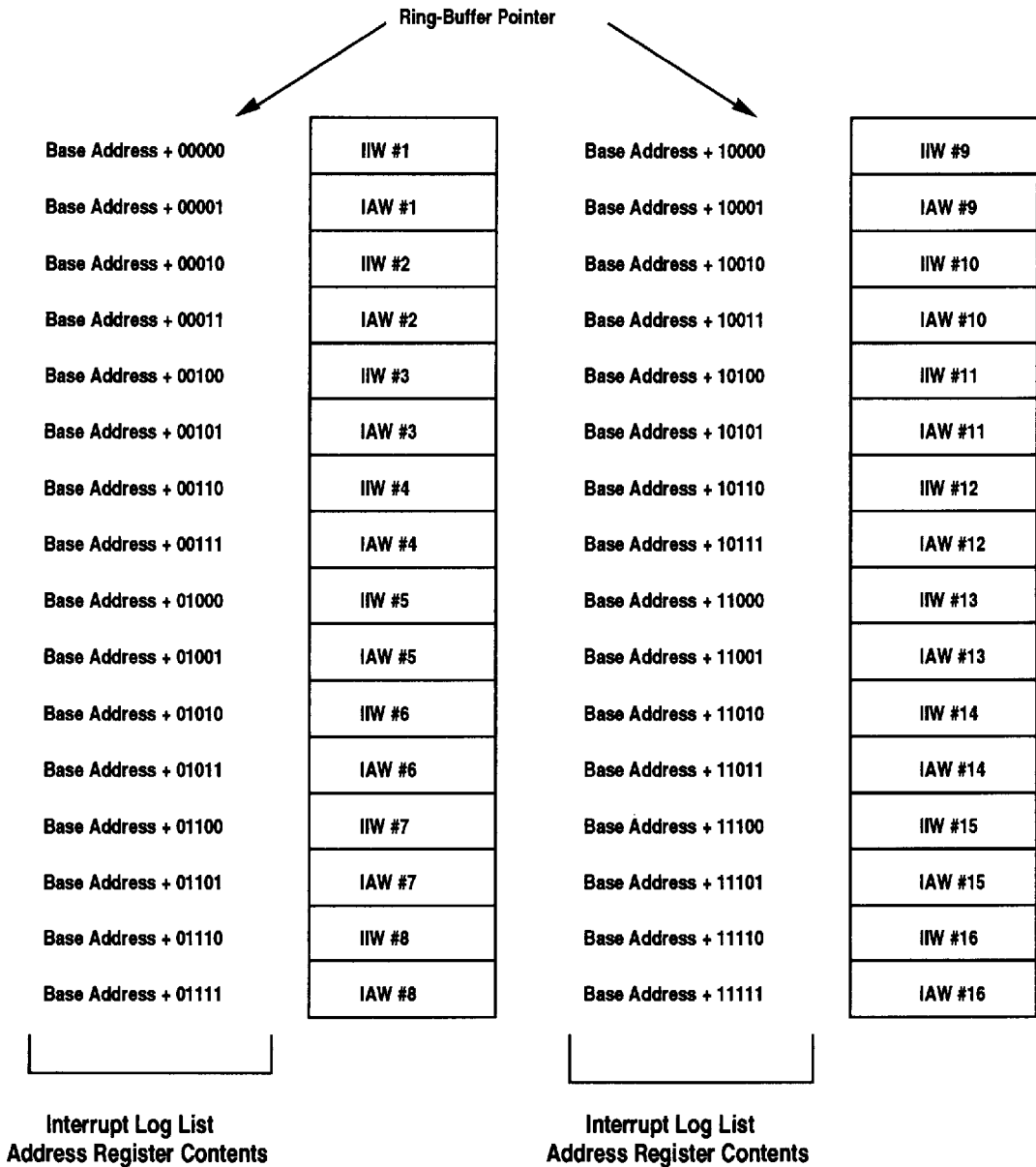

Figure 21. Interrupt Ring Buffer

6.2 S μ MMIT XT

The S μ MMIT XT's interrupt architecture involves three internal registers, an Interrupt Log List, two interrupt outputs, and two interrupt acknowledges. The three internal registers include a Pending Interrupt Register, Interrupt Mask Register, and Interrupt Log List Register. See figure 20 and register descriptions for additional information. The Pending Interrupt Register contains information that identifies the events generating the interrupts. The Interrupt Mask Register allows the user to mask or disable the generation of interrupts. The Interrupt Log List Register contains the base address of a 32-word interrupt ring buffer. Two interrupt outputs signal the occurrence of an interrupt event. The interrupt architecture differentiates interrupts as either a hardware interrupt (**YF_INT**) or message interrupt (**MSG_INT**). The user programs the interrupt outputs as either pulsed outputs or level outputs depending on system requirements.

Assertion of the **YF_INT** interrupt signals a hardware failure condition. Failures include DMA time-out, wrap-around self-test, terminal address parity, or built-in test (BIT). **YF_INT** failures are reflected in the four most significant bits of the Pending Interrupt Register. The **YF_INT** output asserts on the occurrence of a failure.

Assertion of the **MSG_INT** interrupt signals a message related event has occurred. **MSG_INT** events are reflected in the 12 least significant bits of the Pending Interrupt Register. The **MSG_INT** asserts after message processing is complete.

The interrupt architecture allows for the entry of 16 interrupts into a 32-word ring buffer (see figure 20). The S μ MMIT XT automatically handles the interrupt logging overhead. Each interrupt generates two words of information to help the host or subsystem perform interrupt processing. The Interrupt Identification Word (IIW) identifies the type(s) of interrupt that occurred. The Interrupt Address Word (IAW) identifies the interrupt source (e.g., subaddress or command block) via a 16-bit address.

The S μ MMIT XT's interrupt outputs are user programmable. The user can select either pulsed interrupt outputs or level sensitive outputs. In the level mode of operation, assertion of either input (i.e., **YF_ACK** or **MSG_ACK**) negates the respective interrupt output (i.e., **YF_INT** or **MSG_INT**). The state of MSEL(4) selects the mode of operation, Table 10 reviews operation.

Table 10. MSEL(4) Operation

MSEL(4)	YF_INT MSG_INT	YF_ACK MSG_ACK
0	Pulse Output	Tied High
1	Level Output	Active Low

6.2.1 Interrupt Identification Word (IIW)

The Interrupt Identification Word (IIW) is a 16-bit word identifying the interrupt type(s). The format is similar to the Pending Interrupt Register. The host or subsystem reads the IIW to determine which interrupt event occurred. The bit descriptor for the IIW is provided below in Table 9.

6.2.2 Interrupt Address Word (IAW)

The Interrupt Address Word (IAW) is a 16-bit word that identifies the interrupt source. Depending on the mode of operation (i.e., SRT, SBC, or SMT), the IAW has different meanings. In the SRT mode of operation, the IAW identifies the subaddress or mode code descriptor that generated the interrupt. For the SBC mode of operation, the IAW points to the command block addressed when the interrupt occurred. In the SMT mode of operation, the IAW marks the monitor counter count when the interrupt occurred. The host uses the IAW with the Initial Monitor Command Block Pointer Register to determine the monitor command block that generates the interrupt.

When the SMT is operating concurrently with the SRT, the host must determine if the IAW contains information for the SRT or SMT. The determination is made by comparing the contents of the IAW base address with the descriptor base address. If a match occurs, then the IAW contains a subaddress or mode code identifier. If no match occurs, the IAW contains monitor counter information.

6.2.3 Interrupt Log List Address

The interrupt log list resides in a 32-word ring buffer. The host or subsystem defines the location buffer, within a 32K x 16 memory space, via the Interrupt Log List Register (Register 5). Restrict the ring buffer address to a 32-word boundary.

During initialization the host or subsystem writes a value to the Interrupt Log List Pointer Register. Initialize the least significant five bits to a logic zero. The most significant 11 bits determine the base address of the buffer. The SμMMIT XT increments the ring buffer pointer on the occurrence of the first interrupt, storing the IIW and IAW at locations 00000 and 00001 respectively. The SμMMIT XT logs ensuing interrupts sequentially into the ring buffer until interrupt number 16 occurs. The SμMMIT XT enters interrupt 16's IIW in buffer location 11110 and the IAW at location 11111. The ring wraps-around at a value of 11111.

The SμMMIT XT increments the ring buffer pointer as interrupts occur. The least significant five bits of the Interrupt Log List Pointer Register reflect the ring buffer pointer value. Figure 20 shows the ring buffer architecture.

The host or subsystem reads ring buffer pointer value to determine the number of interrupts that have occurred. By extracting the least significant five bits from the Interrupt Log List Register and logical shifting the data once to the right, the host or subsystem determines the number of interrupt events.

7.0 AUTO-INITIALIZATION

7.1 μ MMIT & μ MMIT LX/DX

The μ MMIT & μ MMIT LX/DX auto-initialization feature allows autonomous operation. The μ MMIT & μ MMIT LX/DX will automatically configure itself for operation from by 16 nonvolatile memory (PROM, ROM, E²PROM, EPROM, etc.). The configuration sequence begins after the negation of input pin $\overline{\text{MRST}}$, if $\overline{\text{AUTOEN}}$ is enabled. For each mode of operation, the auto-initialization function is different. The following section outlines the auto-initialization feature for each mode of operation.

7.1.1 SRT Auto-Initialization

During auto-initialization, the μ MMIT & μ MMIT LX/DX loads all internal registers and transfers the descriptor space into RAM. Initialize registers not used during SRT operation to 0000 (hex). The SRT must have 32 memory locations allocated for register data.

Following register initialization, the μ MMIT & μ MMIT LX/DX reads the descriptor from ROM and enters the descriptor into RAM. The starting address for the descriptor is read from the Descriptor Pointer Register. The μ MMIT & μ MMIT LX/DX internally generates all address information required for auto-initialization.

The μ MMIT & μ MMIT LX/DX requires 544 consecutive ROM locations for initialization. The 544 memory locations include: 32 for internal register information, 256 for subaddress descriptor information, and 256 for mode code descriptor information. Unused descriptor blocks should be initialized to four words of 0000 (hex).

The SRT accesses 544 consecutive memory locations in 32-word blocks. The SRT arbitrates for the bus once. Once access is granted, the SRT reads 32 words from ROM, then transfers the information into RAM. The SRT does not release the bus until all 544 ROM locations are transferred. The SRT does not respond to MIL-STD-1553 commands until initialization is complete, the start execution bit has been set, and the RT parity has been verified. After initialization, the SRT can respond to MIL-STD-1553 commands.

7.1.2 SMT Auto-Initialization

SMT auto-initialization requires only the loading of internal registers. Registers not used during SMT operation should be initialized to 0000 (hex). The SMT requires allocation of 32 memory locations for register data. The μ MMIT & μ MMIT

LX/DX internally generates all address information for auto-initialization.

When operating as a concurrent SRT and SMT, the μ MMIT & μ MMIT LX/DX loads all internal registers for both SRT and SMT modes of operation. The device then transfers the descriptor from ROM to RAM.

7.1.3 SBC Auto-Initialization

During auto-initialization the μ MMIT & μ MMIT LX/DX loads all internal registers and transfers the command block(s) into RAM. Registers not used during SBC operation should be initialized to 0000 (hex). The SBC requires the allocation of 32 memory locations for register data.

Following register initialization, the μ MMIT & μ MMIT LX/DX reads command block(s) information from ROM and enters them into RAM. The starting address for the command block(s) is read from the Command Block Pointer Register. The μ MMIT & μ MMIT LX/DX internally generates all address information for auto-initialization.

The SBC continues to read command blocks from ROM until the Command Block Initialization Count Register decrements to zero.

7.1.4 Auto-Initialization Hardware

To enable the auto-initialization function, assert the $\overline{\text{AUTOEN}}$ pin before the rising edge of $\overline{\text{MRST}}$. The assertion of $\overline{\text{MRST}}$ signals the beginning of the auto-initialization sequence. The assertion of output $\overline{\text{ROMEN}}$ enables the ROM for data access. Output $\overline{\text{ROMEN}}$ remains active until the completion of auto-initialization. Simultaneous with the assertion of $\overline{\text{ROMEN}}$, the μ MMIT & μ MMIT LX/DX arbitrates for the bus by asserting $\overline{\text{DMAR}}$. Upon completion of auto-initialization, the μ MMIT & μ MMIT LX/DX asserts the $\overline{\text{READY}}$ output pin. Output $\overline{\text{READY}}$ asserts after negation of $\overline{\text{DMACK}}$. At this time, the μ MMIT & μ MMIT LX/DX is prepared for operation, if it has been started (i.e., $\text{STEX}=1$). The μ MMIT & μ MMIT LX/DX is idle until reception of a valid command word, or begins command block processing.

The ROM's starting location is 0000 (hex), RAM and ROM are overlaid by using the $\overline{\text{ROMEN}}$ output pin as a ROM device select or output enable. Figures 22a and 22b show examples of the relative timing associated with an auto-initialization sequen

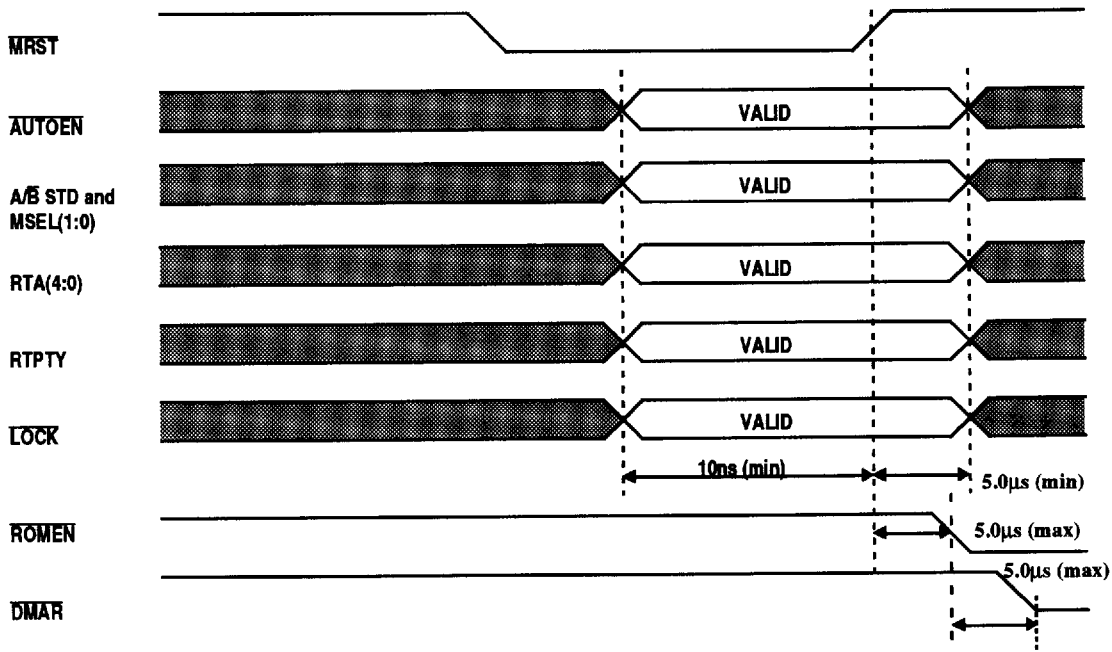

Note:

UTMC strongly recommends that these inputs remain static until the assertion of **READY**.

Figure 22a. Auto-Initialization Timing

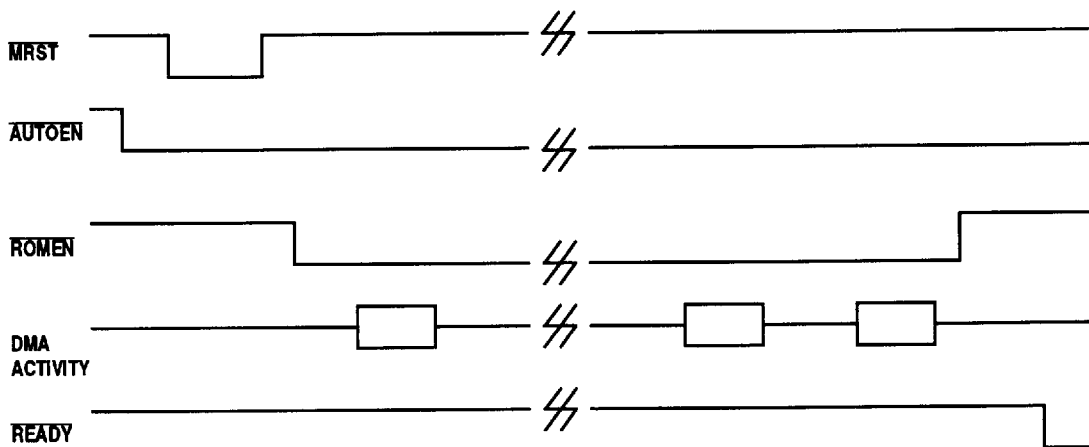

Figure 22b. Auto-Initialization DMA Sequence

7.2 SμMMIT XT

The SμMMIT XT auto-initialization feature allows autonomous operation. The SμMMIT XT will automatically configure itself for operation from by 8 nonvolatile memory (PROM, ROM, E²PROM, EPROM, etc.). The configuration sequence begins after the negation of input pin $\overline{\text{MRST}}$, if $\overline{\text{AUTOEN}}$ is enabled. For each mode of operation, the auto-initialization function is different. The following sections outline the auto-initialization feature for each mode of operation.

7.2.1 SRT Auto-Initialization

During auto-initialization, the SμMMIT XT loads all internal registers and transfers the descriptor space into RAM. Initialize registers not used during SRT operation to 0000 (hex). The SRT must have 64 memory locations allocated for register data.

Following register initialization, the SμMMIT XT reads the descriptor from ROM and enters the descriptor into RAM. The starting address for the descriptor is read from the Descriptor Pointer Register. The SμMMIT XT internally generates all address information required for auto-initialization.

The SμMMIT XT requires 1088 consecutive ROM locations for initialization. The 1088 memory locations include: 64 for internal register information, 512 for subaddress descriptor information, and 512 for mode code descriptor information. Unused descriptor blocks should be initialized to four words of 0000 (hex).

The SRT accesses 1088 consecutive memory locations in 64-word blocks. Once access is granted, the SRT reads words from ROM, then transfers the information into RAM. The SRT does not respond to MIL-STD-1553 commands until initialization is complete, the start execution bit has been set, and the RT parity has been verified. After initialization, the SRT can respond to MIL-STD-1553 commands.

7.2.2 SMT Auto-Initialization

SMT auto-initialization requires only the loading of internal registers. Registers not used during SMT operation should be initialized to 0000 (hex). The SMT requires allocation of 64 memory locations for register data. The SμMMIT XT internally generates all address information for auto-initialization.

When operating as a concurrent SRT and SMT, the SμMMIT XT loads all internal registers for both SRT and SMT modes of operation. The device then transfers the descriptor from ROM to RAM.

7.2.3 SBC Auto-Initialization

During auto-initialization the SμMMIT XT loads all internal registers and transfers the command block(s) into RAM. Registers not used during SBC operation should be initialized to 0000 (hex). The SBC requires the allocation of 64 memory locations for register data.

Following register initialization, the SμMMIT XT reads command block(s) information from ROM and enters them into RAM. The starting address for the command block(s) is read from the Command Block Pointer Register. The SμMMIT XT internally generates all address information for auto-initialization.

The SBC continues to read command blocks from ROM until the Command Block Initialization Count Register decrements to zero.

7.2.4 Auto-Initialization Hardware

An external auto-initialization bus allows configuration of SμMMIT XT without host intervention. Auto-initialization is ideal for low cost remote sensing applications where a host microprocessor or microcontroller is not required.

To enable the auto-initialization function, assert the $\overline{\text{AUTOEN}}$ pin prior to the rising edge of $\overline{\text{MRST}}$. The assertion of $\overline{\text{MRST}}$ signals the beginning of the auto-initialization sequence. The SμMMIT XT enables the boot memory by asserting the $\overline{\text{ECS}}$ output. The SμMMIT XT accesses up to 8K x 8 words via the auto-initialization bus. Table 8 reviews the memory requirements for SμMMIT XT auto-initialization.

Table 11. Auto-Initialization Memory Requirements

Mode	Memory (x8)
SRT	1088
SMT	64
SBC	$64 + [N \times (16)]^1$

Note:

1. N equals the number of command blocks.

To interface to slower non-volatile memory the auto-initialization read cycle period is programmable. The user selects between zero and seven wait states per read. A wait state is equal to 82ns. The user programs the read cycle duration via inputs EC(2:0). The SμMMIT XT latches inputs EC(2:0) on the rising edge of MRST. Table 12 reviews the possible combinations of wait-states. Figures 23a and 23b show a system configuration along with typical auto-initialization read cycles. Following completion of an auto-initialization sequence the SμMMIT XT asserts the READY output.

Table 12. Programmable Wait-State

EC(2:0) ₂	Number of Wait-States
000	0
001	1
010	2
011	3
100	4
101	5
110	6
111	7

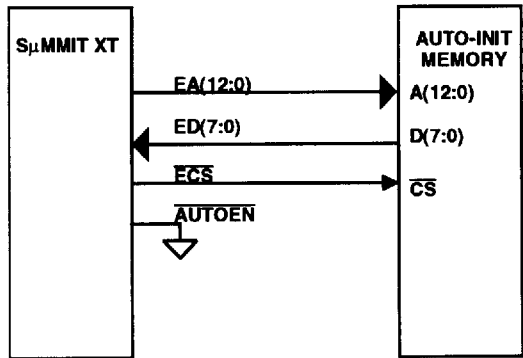
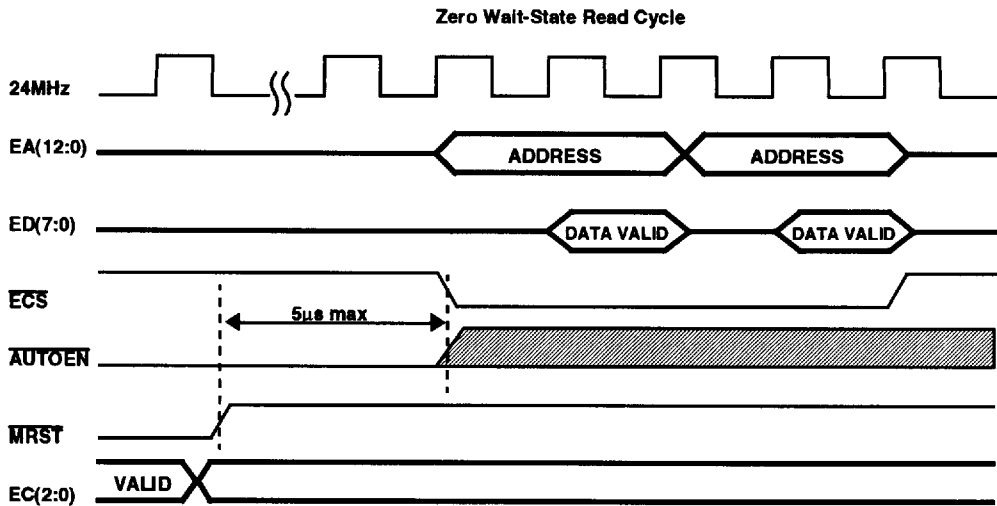

Figure 23a. Auto-Initialization System Configuration



Note:
Two bytes are read on each ECS cycle using only an address transition (AT).

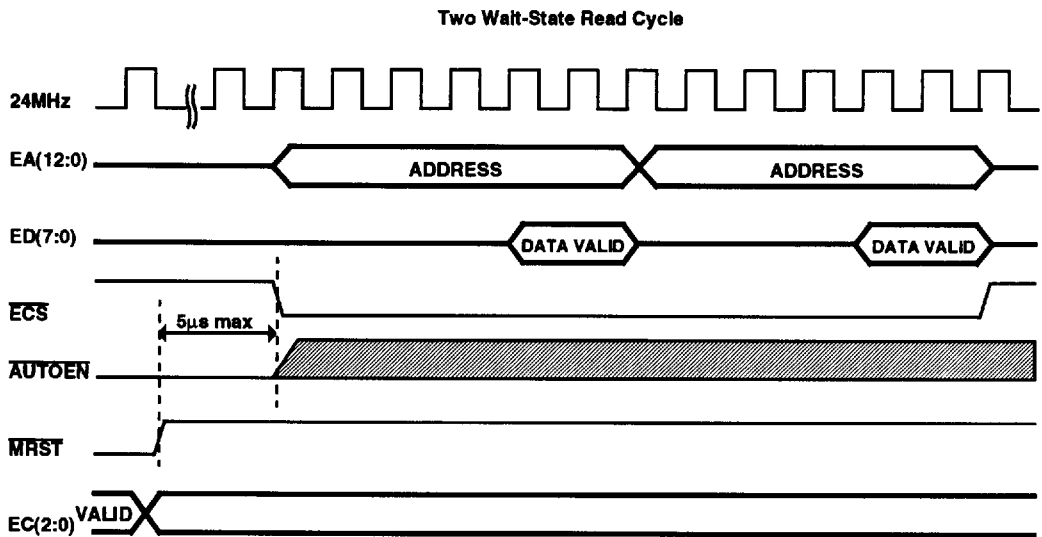

Figure 23b. Auto-Initialization Read Cycle

8.0 Testability

The following sections review the built-in test capabilities of the S μ MMIT family. The S μ MMIT family ranges from the simple S μ MMIT to the complex S μ MMIT XT. The varying complexity results in slightly different test techniques to exercise each product type. Table 13 is a list of the various components that comprehend each of the different S μ MMIT product.

Table 13. S μ MMIT Family Internal Component List

Product	Protocol Die	Transceivers	Memory	MMU
S μ MMIT	Yes	No	No	No
S μ MMIT LX	Yes	Yes	No	No
S μ MMIT DX	Yes	Yes	No	No
S μ MMIT XT	Yes	Yes	Yes	Yes

A S μ MMIT product's built-in test (BIT) varies depending on the product's internal component mix and the BIT initiating sequence. BIT's execution time will also vary depending on the number of internal components under test. Table 14 reviews the various BIT initiation sequences and the components that the sequence tests along with BIT execution times.

Table 14. BIT Initiation

Initiation Type	Protocol Die	Transceivers ¹	Memory	MMU	Execution Time ²
CPU Initiated ²	Yes	No	Yes	No	1mS/70mS
Mode Code Initiated ⁴	Yes	No	No	No	1mS
Op-Code Initiated ⁵	Yes	No	No	No	1mS
JTAG 1149.1	Yes	No	No	Yes	N/A
JTAG/RUNBIST	Yes	No	No	No	1mS

Notes:

1. The transceiver is tested with the data wrap-around feature of the S μ MMIT family. See sections 2.1.5, 3.1.5, 4.1.5.
2. Control Register write of 4000₁₆.
3. Remote Terminal mode of operation, BIT initiated after reception of mode code command.
4. Bus Controller mode of operation, BIT initiated after the fetch of a command block containing an initiate BIT op-code.
5. S μ MMIT test 1mS. Memory test 70mS.

9.0 SYSTEM CONFIGURATION

9.1 S μ MMIT & S μ MMIT LX/DX

9.1.1 Transmitter/Receiver Interface

The S μ MMIT Manchester II encoder/decoder interfaces directly with the UT63M100 Series Bus Transceiver, using TA-T \bar{A} and RA-R \bar{A} signals for Channel A, and TB-T \bar{B} and RB-R \bar{B} signals for Channel B. See appendix 1 for additional information on UTMC transceivers. The S μ MMIT also provides TIMERONA and TIMERONB output signals to assist in meeting the MIL-STD-1553B fail-safe timer requirements (see figures 24a and 24b). Reference section 10 for S μ MMIT LX/DX serial bus interface information.

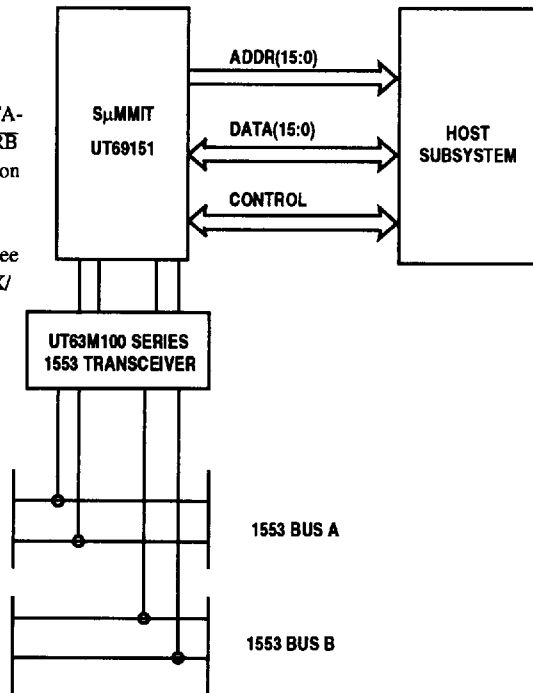

Figure 24a. S μ MMIT General System Diagram

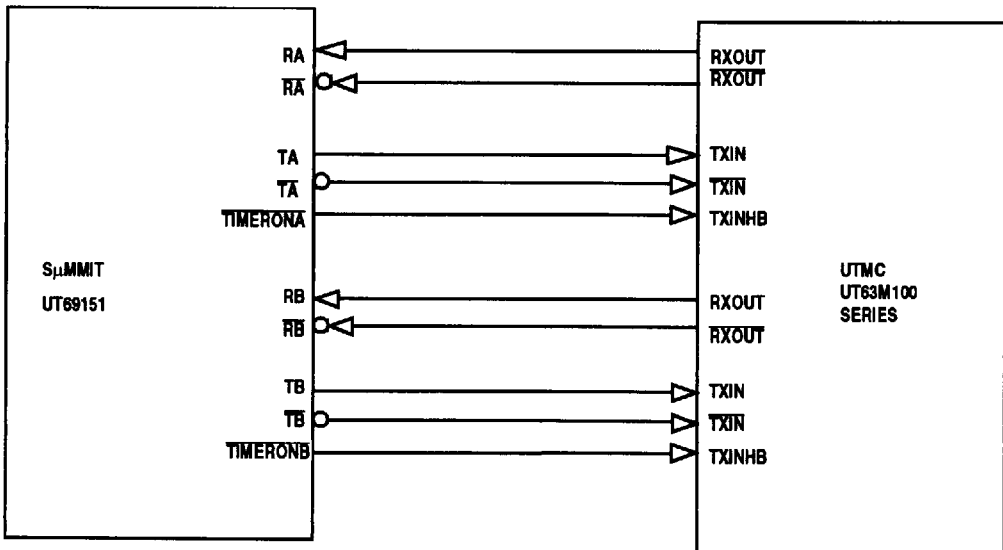

Figure 24b. S μ MMIT Transceiver Interface Diagram

9.1.2 Register Transfers

The host's or subsystem's access to the S μ MMIT & S μ MMIT LX/DX internal registers is similar to its access to RAM. After gaining control of the memory bus, the host supplies address information to bidirectional address bus pins A(4:0). After supplying the address information, the host asserts S μ MMIT & S μ MMIT LX/DX inputs \overline{CS} and RD/ \overline{WR} to designate a register access and the type of access. The memory access terminates on the negation of \overline{CS} . For more information on register cycles refer to the timing diagrams and AC electrical specifications in section 20. For register utilization versus mode of operation see Table 15.

Note: Modifying (i.e., writing) internal registers is not recommended while the S μ MMIT & S μ MMIT LX/DX is processing messages (i.e., TERA \overline{CT} active). The only exception occurs when the S μ MMIT & S μ MMIT LX/DX is in the SBC mode of operation where a write to bit 15 of the Control Register is permitted.

Table 15. Internal Register Utilization

Register Number	Register Number 8-Bit Mode (S μ MMIT XT only)	Register Name	SRT	SBC	SMT
0	0,1	Control	✓	✓	✓
1	2,3	Operational Status	✓	✓	✓
2	4,5	Current Command	✓	✓	✓
3	6,7	Interrupt Mask	✓	✓	✓
4	8,9	Pending Interrupt	✓	✓	✓
5	A,B	Interrupt Log List	✓	✓	✓
6	C,D	BIT Word	✓	✓	✓
7	E,F	Time Tag (SRT and SMT) Miner Frame Timer (SBC)	✓	✓	✓
8	10,11	SRT Descriptor Pointer (SRT) Command Block Pointer (SBC)	✓	✓	
9	12,13	1553 Status Word Bits	✓		
A	14,15	Command Block Initialization Count (BC)		✓	
B	16,17	Initial Monitor Command Block Pointer			✓
C	18,19	Initial Monitor Data Pointer			✓
D	1A,1B	Monitor Block Count			✓
E	1C,1D	Monitor Filter			✓
F	1E,1F	Monitor Filter			✓
10 to 1F	20 to 3F	Illegalization	✓ (16)		
Total			26	10	13

9.1.3 DMA Configuration

For a DMA system configuration the S μ MMIT & S μ MMIT LX/DX shares memory with the host and/or subsystem. The S μ MMIT & S μ MMIT LX/DX gains access to memory through an arbitration process. The S μ MMIT & S μ MMIT LX/DX requests access to memory by asserting the \overline{DMAR} signal. After receiving a grant signal (i.e., assertion of \overline{DMAG}) from the bus arbiter, the S μ MMIT & S μ MMIT LX/DX asserts \overline{DMACK} to acknowledge control of the bus. The S μ MMIT & S μ MMIT LX/DX continues to assert \overline{DMACK} until all accesses are complete. After completion of all accesses, \overline{DMACK} negates releasing the bus. Figure 25 shows an example DMA system configuration.

9.1.4 DMA Transfers

Following the assertion of \overline{DMACK} , the S μ MMIT activates the address bus A(15:0). During write cycles, the bidirectional data bus D(15:0) activates, supplying data for the write cycle. For read cycles, the bidirectional data bus remains an input. Memory control signals \overline{RCS} , \overline{RRD} , and \overline{RWR} assert following the address bus activation. These signals control the memory chip select, output enable and write inputs. Table 16 is a summary of DMA activity during message processing.

For both read and write memory cycles, \overline{DTACK} is an input to the S μ MMIT & S μ MMIT LX/DX. A non-wait state memory access requires two clock cycles. For accessing slower memory devices, hold \overline{DTACK} to a logical one. This results in the stretching of memory cycles beyond the two clock cycles. The S μ MMIT & S μ MMIT LX/DX samples \overline{DTACK} on the rising edge of the 24 MHz clock. If the memory logic fails to assert \overline{DTACK} before the rising edge of the clock, the S μ MMIT & S μ MMIT LX/DX extends the memory cycle. One clock cycle is added to the memory cycle and \overline{DTACK} is again sampled on the clock rising edge. If \overline{DTACK} remains negated, the S μ MMIT & S μ MMIT LX/DX continues to add one clock cycle to the memory cycle and samples \overline{DTACK} on each rising edge of the clock.

UTMC's UT54ACS220/UT54ACTS220 automatically generates one wait state for either the S μ MMIT or S μ MMIT LX/DX. See figure 26 for additional information. See appendix 2 for additional information on the UT54ACS220/UT54ACTS220.

Assertion of \overline{DTACK} signals the S μ MMIT & S μ MMIT LX/DX to terminate the memory cycle. The memory cycle terminates one clock cycle after \overline{DTACK} assertion. For more information on memory cycles, refer to the timing diagrams and AC electrical specifications in section 20.

9.1.5 Buffer Mode Operation

The S μ MMIT & S μ MMIT LX/DX have the optional use of an internal 32-word buffer to enhance message processing. Use of this internal buffer decreases the number of times the S μ MMIT & S μ MMIT LX/DX arbitrates for memory during message processing. The number of memory accesses required to process a command is dependent on the mode of operation (SRT, SBC, SMT).

The S μ MMIT & S μ MMIT LX/DX stores all data words associated with a receive message into memory using a single DMA burst. When transmitting information, the S μ MMIT & S μ MMIT LX/DX arbitrates for a memory access and extracts all data for transmission from external memory in a single DMA burst. For either receive or transmit messages, the S μ MMIT & S μ MMIT LX/DX does not release the memory bus until all data is transferred to or from external memory. The buffer mode of operation eliminates the S μ MMIT & S μ MMIT LX/DX arbitration for the bus each time a data word memory access is required.

To enable use of the internal message buffer, the host asserts bit 6 of the Control Register. If the buffer feature is not enabled, the S μ MMIT & S μ MMIT LX/DX arbitrates each time data storage or retrieval is required. The host or subsystem does not have access to this internal buffer.

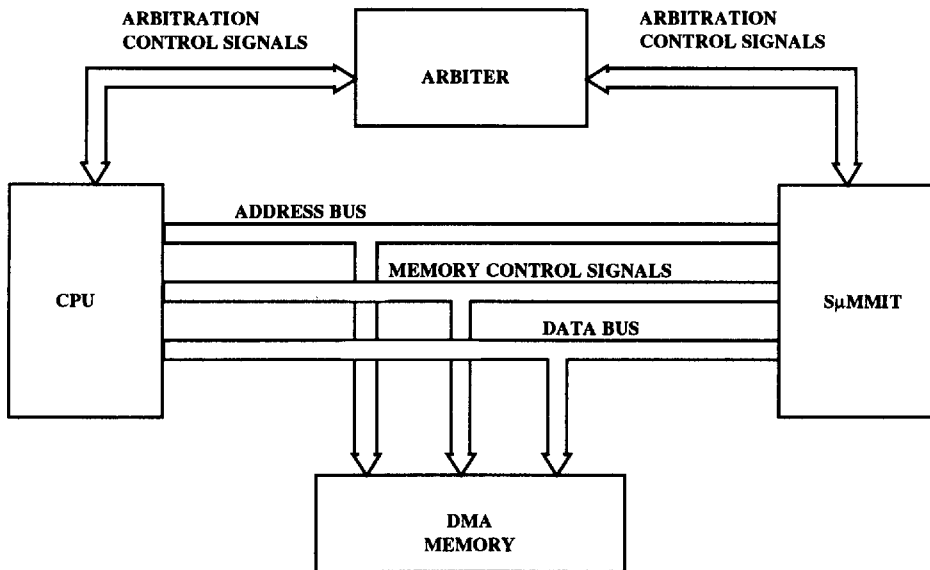

Figure 25. DMA System Configuration

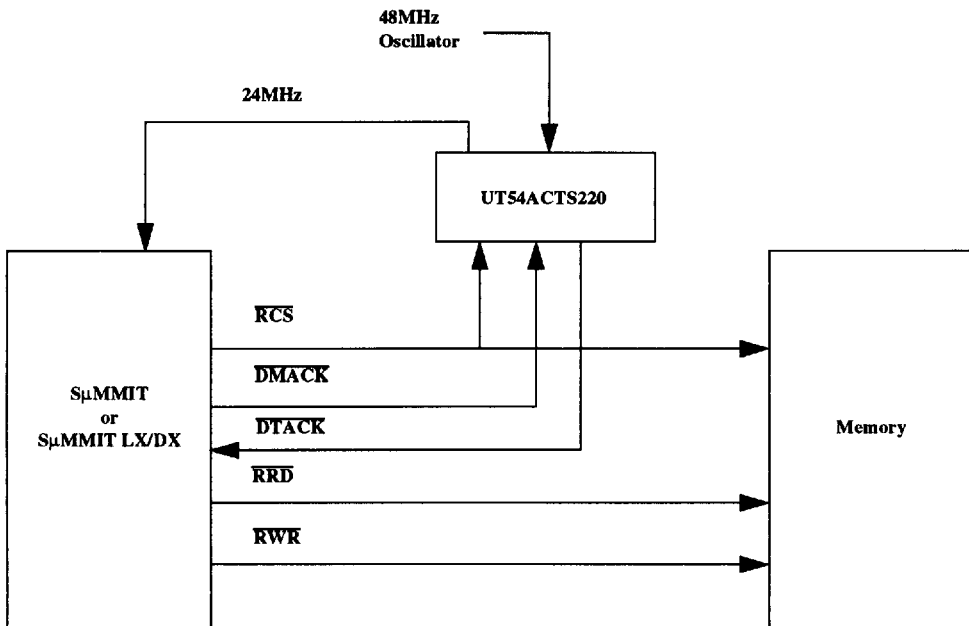

Figure 26. Wait-State Configuration using UT54ACTS220

Table 16. DMA

BC Write Scenario

Number of Words	Word Type
1-32 ¹	Data Word
2	Interrupt Information Word Interrupt Address Word
6	Control Word Cmd Word 1 Cmd Word 2 Data Pointer Status Word 1 Status Word 2
8	Control Word Cmd Word 1 Cmd Word 2 Data Pointer Status Word 1 Status Word 2 Interrupt Information Word Interrupt Address Word

BC Read Scenario

Number of Words	Word Type
1-32 ¹	Data Word
8	Control Word Cmd Word 1 Cmd Word 2 Data Pointer Status Word 1 Status Word 2 Branch Address Timer Value

Monitor Write Scenario

Number of Words	Word Type
1-32 ¹	Data Word
7	Control Word Cmd Word 1 Cmd Word 2 Data Pointer Status Word 1 Status Word 2 Time Tag
9	Control Word Cmd Word 1 Cmd Word 2 Data Pointer Status Word 1 Status Word 2 Time Tag Interrupt Status Word Interrupt Address Word

RT Write Scenario

Number of Words	Word Type
1-32 ¹	Data Word
3	Message Information Word Time-Tag Word Control Word
4	Message Information Word Time-Tag Word Control Word Data Pointer
5	Message Information Word Time-Tag Word Control Word Interrupt Information Word Interrupt Address Word
6	Message Information Word Time-Tag Word Control Word Data Pointer Interrupt Information Word Interrupt Address Word

RT Read Scenario

Number of Words	Word Type
1-32 ¹	Data Word
4	Control Word Data Pointer A Data Pointer B Broadcast Data Pointer

Note:

1. If buffer mode selected, more than 1 and up to 32 words can be read/written.

9.2 μ MMIT XT

The μ MMIT XT supplies hardware designers with a flexible interface to meet the needs of state-of-the-art MIL-STD-1553 interfaces. The μ MMIT XT contains internal SRAM and a memory management unit, interfaces to either 8-bit or 16-bit subsystems, supports multiplexed and non-multiplexed interfaces, and has user selectable control signals.

9.2.1 Internal Registers

The μ MMIT XT contains 32 internal registers that control and report on message activity and operation. The 32 registers are memory mapped into the subsystem memory. Table 17 reviews the registers and identifies the mode of operation they are applicable. The host reads or writes these registers using the timing diagrams shown in figures 27 a-d.

9.2.2 Memory Map

The μ MMIT XT contains 512Kbits of memory for message storage and system data storage. MSEL(5) determines the organization of the memory as either by 16 or by 8. When organized by 16 (i.e., MSEL(5)=0) the μ MMIT XT's internal memory looks like 32K x 16 of SRAM. For by 8 applications (MSEL(5) = 1) the μ MMIT XT's internal memory looks like

64K x 8 of SRAM. The host reads or writes SRAM using the timing diagrams shown in figures 27 a-d. Table 17 shows the memory organization for either 8-bit or 16-bit operation.

9.2.3 Buffer Mode Operation

For the μ MMIT XT operation, disable buffer mode, i.e., control register bit 6 = Logic 0.

9.2.4 Hardware Interface

The μ MMIT XT offers hardware designers a flexible interface to commonly found embedded computers. The hardware designer selects control signals, bus widths, and bus functionality (i.e., non-multiplexed versus multiplexed) to meet their interface requirements. Table 18 reviews how the user selects the μ MMIT XT's operation that best meets their interface requirements.

Figures 28 a-d show typical system interfaces and use of the mode select inputs to configure the μ MMIT XT to interface to various embedded computers.

Table 17. Memory Organization

Mode	Memory Organization	Register Location	Memory Range
8-bit	64K x 8	0000 (hex) to 003F (hex)	0040 (hex) to FFFF (hex)
16-bit	32K x 16	0000 (hex) to 001F (hex)	0020 (hex) to 7FFF (hex)

Table 18. User-Selectable Control Signals

Function	Input Pin	Logic 1	Logic 0
Control Signal Select	MSEL(2)	R/WR, CS, DS, RDY	RD, WR, CS, RDY, DS
Bus Functionality Select	MSEL(3)	Non-Multiplexed Address and Data	Multiplexed Address and Data, ALE
Interrupt Select	MSEL(4)	Level (YF_INT, MSG_INT, YF_ACK, and MSG_ACK)	Pulse (YF_INT and MSG_INT)
Bus Width Select	MSEL(5)	8-bit	16-bit

Non-Multiplexed Memory/Register Write Access (8-bit Mode)^{1,2}

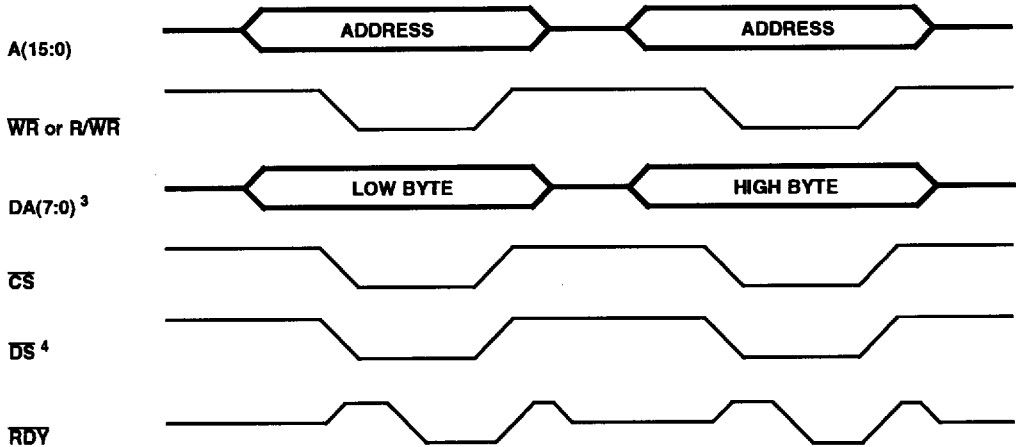

Notes:

1. ALE must be tied high.
2. Logical "and" of CS, DS, WR starts memory cycle.
3. Tie DA(15:8) to V_{DD} via a 10K resistor.
4. DS asserts to signal that data is valid on the bus.

Non-Multiplexed Memory/Register Read Access (8-bit Mode)^{1,2}

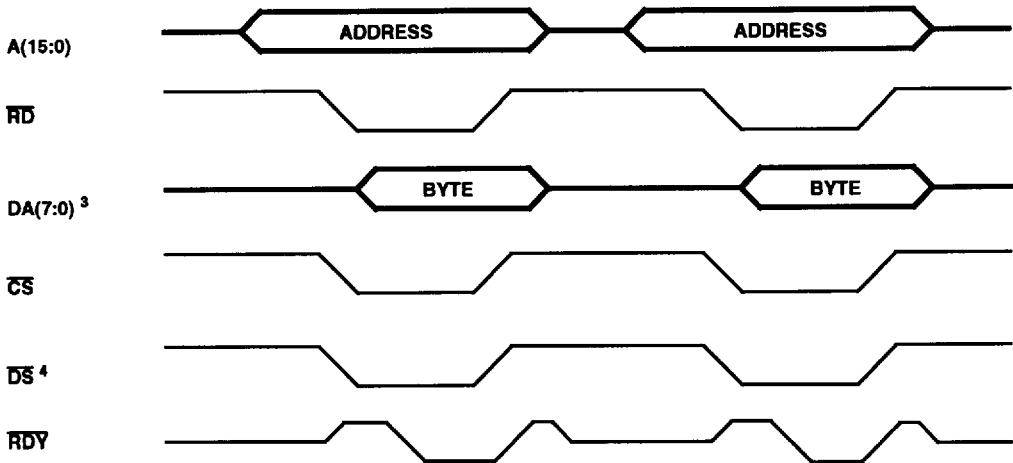

Notes:

1. ALE must be tied high.
2. Logical "and" of CS, DS, WR starts memory cycle.
3. Tie DA(15:8) to V_{DD} via a 10K resistor.
4. DS asserts to signal the SμMMIT XT to place data on the bus.

Figure 27a. 8-bit Memory and Register Access

Non-Multiplexed Memory/Register Write Access (16-bit Mode)^{1,2}

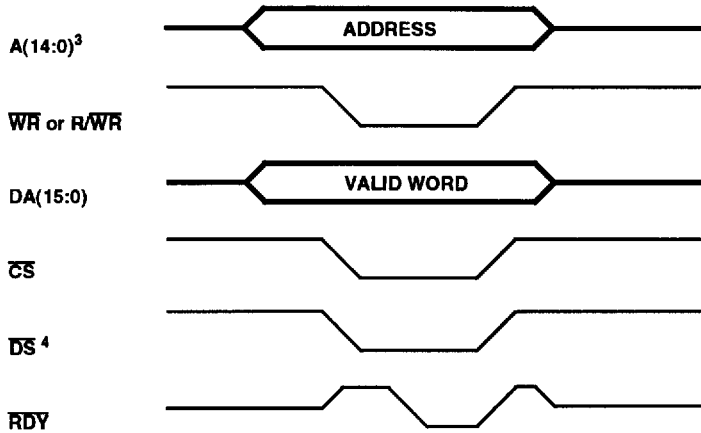

Notes:

1. ALE must be tied high.
2. Logical "and" of \overline{CS} , \overline{DS} , \overline{WR} starts memory cycle.
3. A15 must be tied low.
4. \overline{DS} asserts to signal that data is valid on the bus.

Non-Multiplexed Memory/Register Read Access (16-bit Mode)^{1,2}

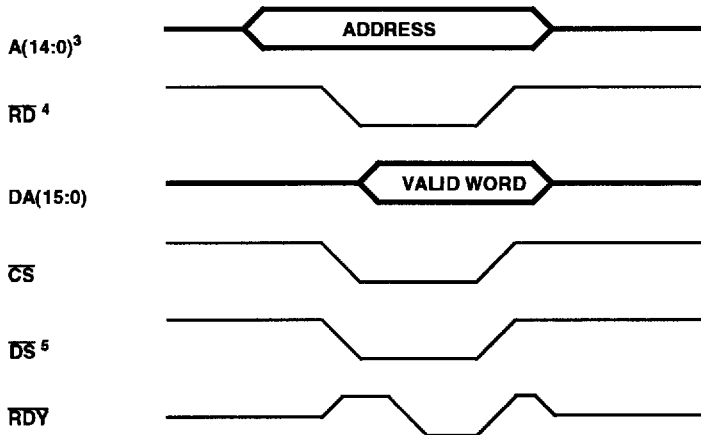

Notes:

1. ALE must be tied high.
2. Logical "and" of \overline{CS} , \overline{DS} , \overline{RD} starts memory cycle.
3. A15 must be tied low.
4. When using R/WR as an input signal tie \overline{RD} to a logical one. During the read cycle R/WR remains a logic 1.
5. \overline{DS} asserts to signal the $\mu\text{MMIT XT}$ to place data on the bus.

Figure 27b. 16-bit Memory and Register Access

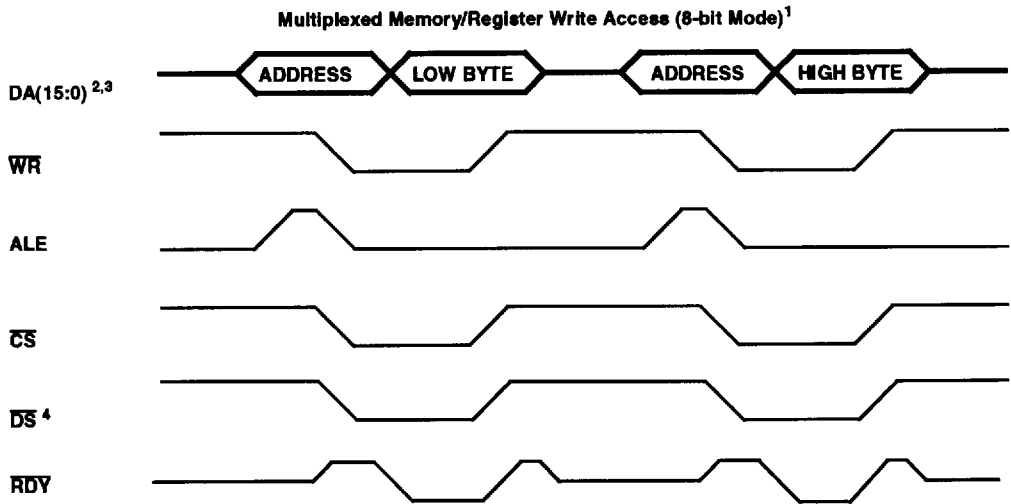

Notes:

1. Logical "and" of \overline{CS} , \overline{DS} , \overline{WR} starts memory cycle.
2. For multiplexed address and data interfaces ALE latches the address into the S μ MMIT XT.
Data is applied to inputs DA(7:0), tie A(15:0) to either a logical one or zero.
3. Tie DA(15:8) to V_{SS} via a 10K resistor.
4. \overline{DS} asserts to signal that data is valid on the bus.

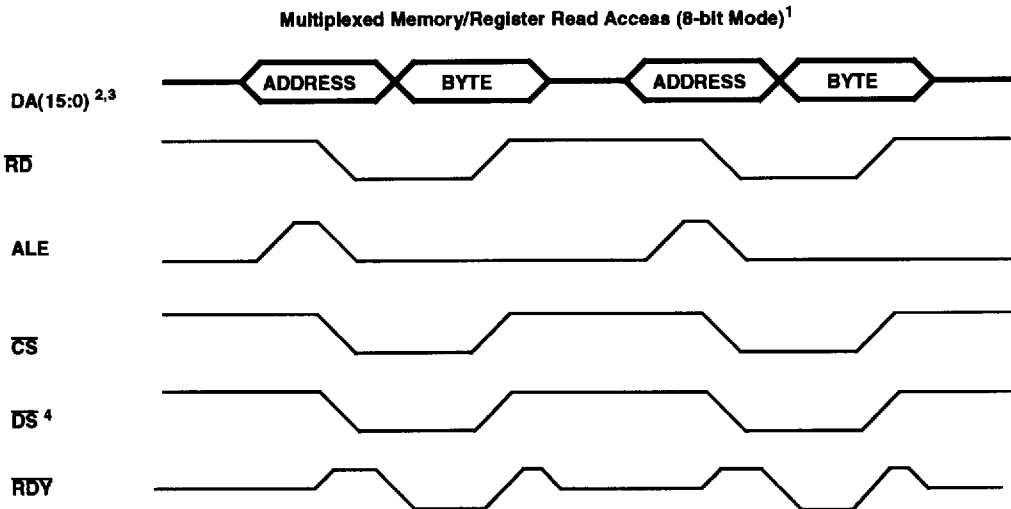

Notes:

1. Logical "and" of \overline{CS} , \overline{DS} , \overline{RD} starts memory cycle.
2. For multiplexed address and data interfaces ALE latches the address into the S μ MMIT XT.
Data is read from outputs DA(7:0), tie A(15:0) to either a logical one or zero.
3. Tie DA(15:8) to V_{SS} via a 10K resistor.
4. \overline{DS} asserts to signal the S μ MMIT XT to place data on the bus.

Figure 27c. Multiplexed 8-bit Memory and Register Access

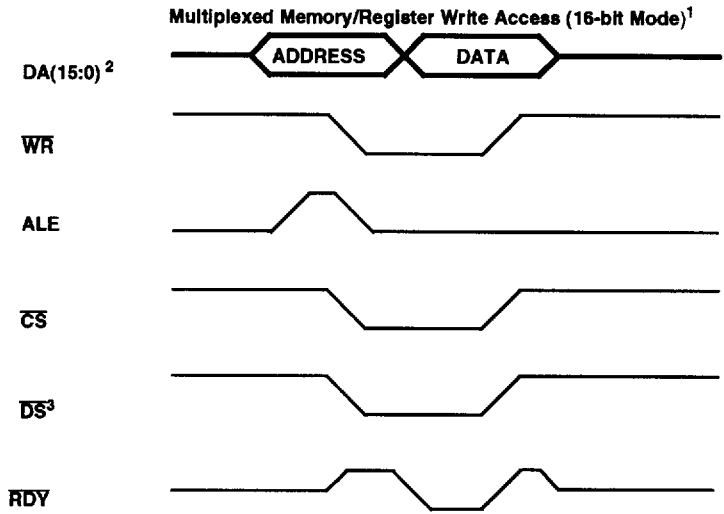

Notes:

1. Logical "and" of \overline{CS} , \overline{DS} , \overline{WR} starts memory cycle.
2. For multiplexed address and data interfaces ALE latches the address into the $\mu\text{MMIT XT}$.
Data is applied to inputs DA(15:0), tie A(15:0) to either a logical one or zero.
3. \overline{DS} asserts to signal that data is valid on the bus.

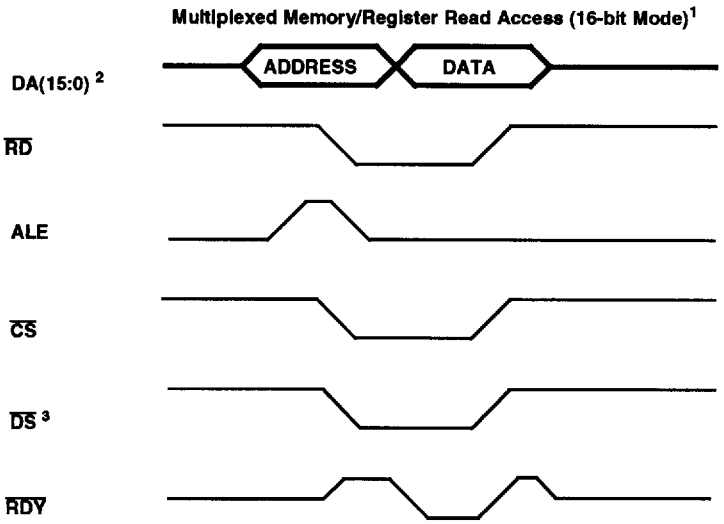

Notes:

1. Logical "and" of \overline{CS} , \overline{DS} , \overline{RD} starts memory cycle.
2. For multiplexed address and data interfaces ALE latches the address into the $\mu\text{MMIT XT}$.
Data is read from outputs DA(15:0), tie A(15:0) to either a logical one or zero.
3. \overline{DS} asserts to signal the $\mu\text{MMIT XT}$ to place data on the bus.

Figure 27d. Multiplexed 16-bit Memory and Register Access

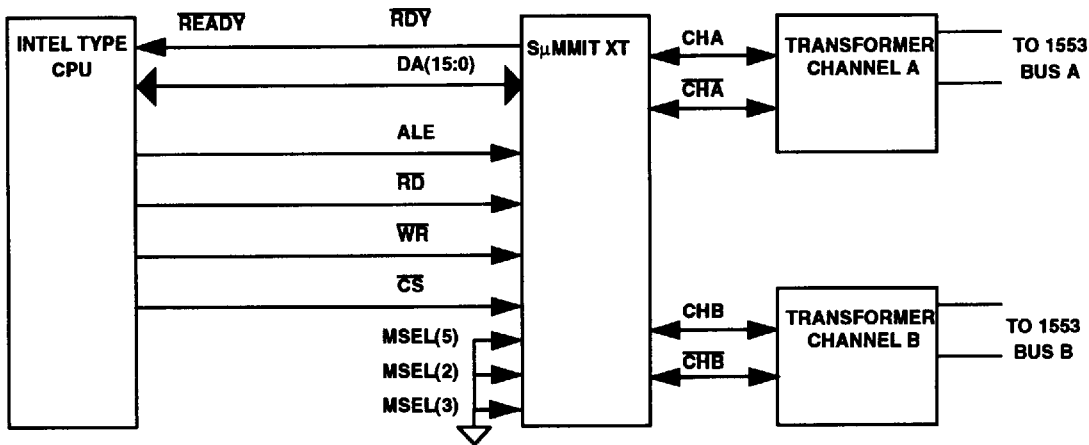

Figure 28a. 16-bit Interface (Intel Type)

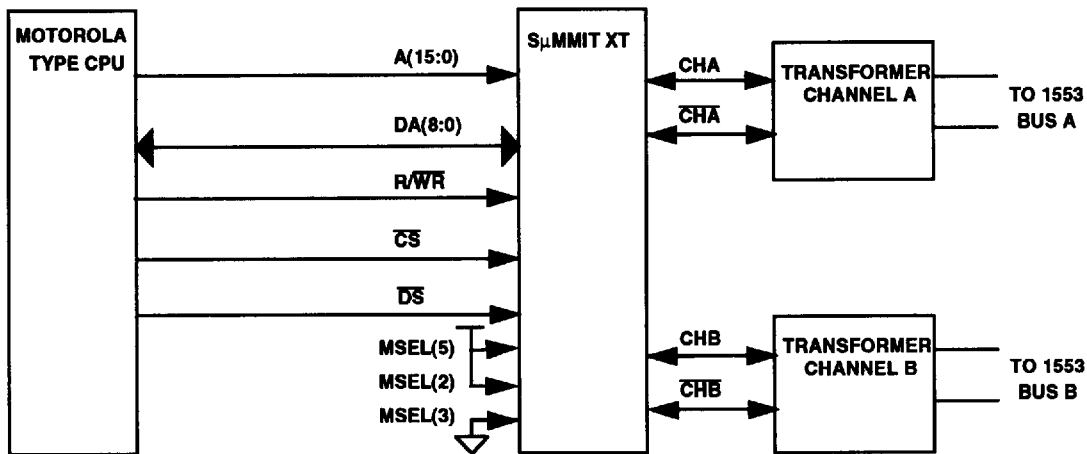

Figure 28b. 16-bit Interface (Motorola Type)

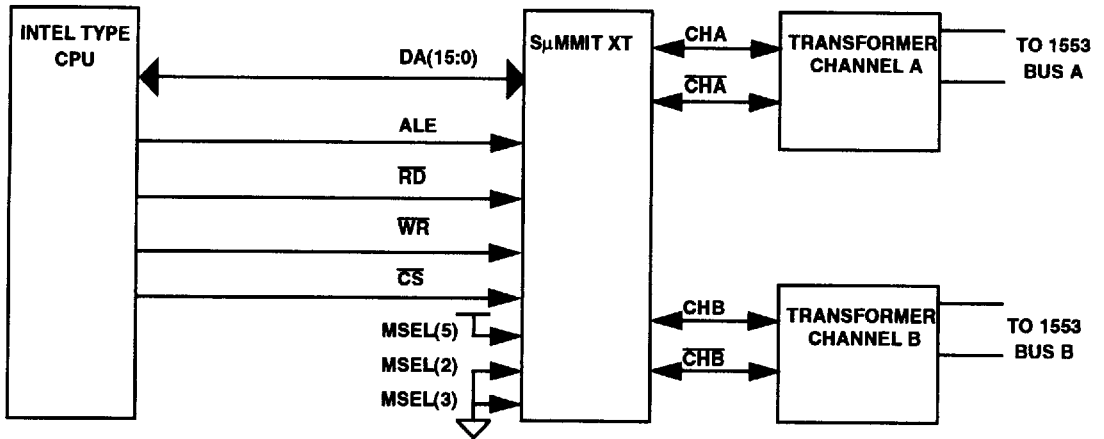

Figure 28c. 8-bit Interface (Intel Type)

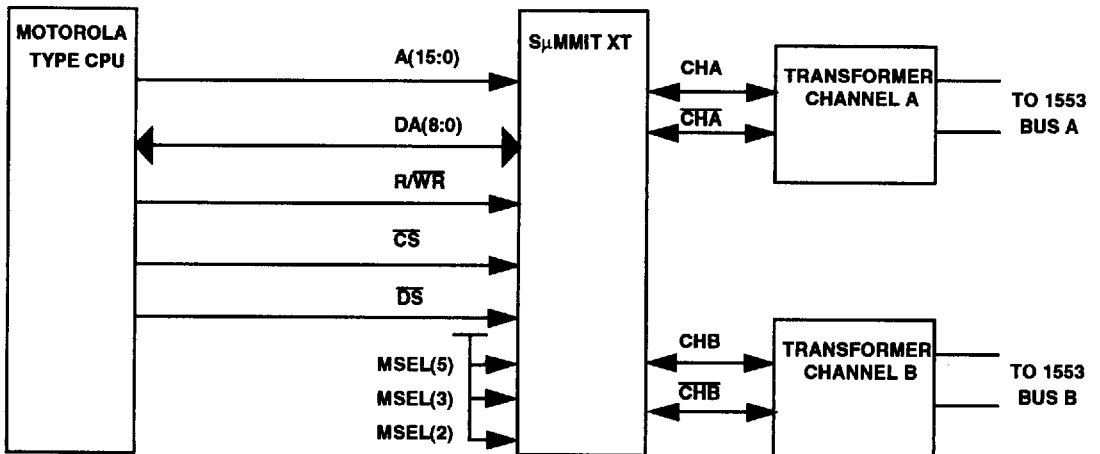

Figure 28d. 8-bit Interface (Motorola Type)

10.0 SERIAL DATA BUS INTERFACE

The S μ MMIT LX/DX & S μ MMIT XT Manchester encoder/decoder interfaces directly to the MIL-STD-1553 bus via transformers, using \overline{CHA} - \overline{CHA} and \overline{CHB} - \overline{CHB} . The designer can connect the S μ MMIT LX/DX & S μ MMIT XT to the data bus via a short-stub (direct-coupling) connection or a long-stub (transformer-coupling) connection. Use a short-stub connection when the distance from the isolation transformer to the data bus does not exceed a one-foot maximum. Use a long-stub connection when the distance from the isolation transformer exceeds the one-foot maximum and is less than twenty feet. Figures 29 a-c show various examples of bus coupling configurations. The S μ MMIT LX/DX & S μ MMIT XT is designed to function with MIL-STD-1553A and 1553B compatible transformers.

10.1 Transmitter

The transmitter section accepts Manchester II biphasic TTL data and converts this data into differential phase-modulated current drive. Transmitter current drivers are coupled to a MIL-STD-1553 data bus via a transformer driven from the \overline{CHA} (\overline{CHB})

and \overline{CHA} (\overline{CHB}) terminals. The S μ MMIT LX/DX & S μ MMIT XT internally generates a signal to the transceiver for the MIL-STD-1553 fail-safe timer requirement.

10.2 Receiver

The receiver section accepts biphasic differential data from a MIL-STD-1553 data bus at its \overline{CHA} (\overline{CHB}) and \overline{CHA} (\overline{CHB}) inputs. The receiver converts input data to biphasic Manchester II TTL format at internal RXOUT and \overline{RXOUT} terminals. The internal outputs RXOUT and \overline{RXOUT} represent positive and negative excursions (respectively) of the inputs \overline{CHA} (\overline{CHB}) and \overline{CHA} (\overline{CHB}).

10.3 Recommended Thermal Protection

All packages should mount to or contact a heat removal rail located in the printed circuit board. To insure proper heat transfer between the package and the heat removal rail, use a thermally-conductive material between the package and the heat removal rail. Use a material such as Mereco XLN-589 or equivalent to insure heat transfer between the package and heat removal rail.

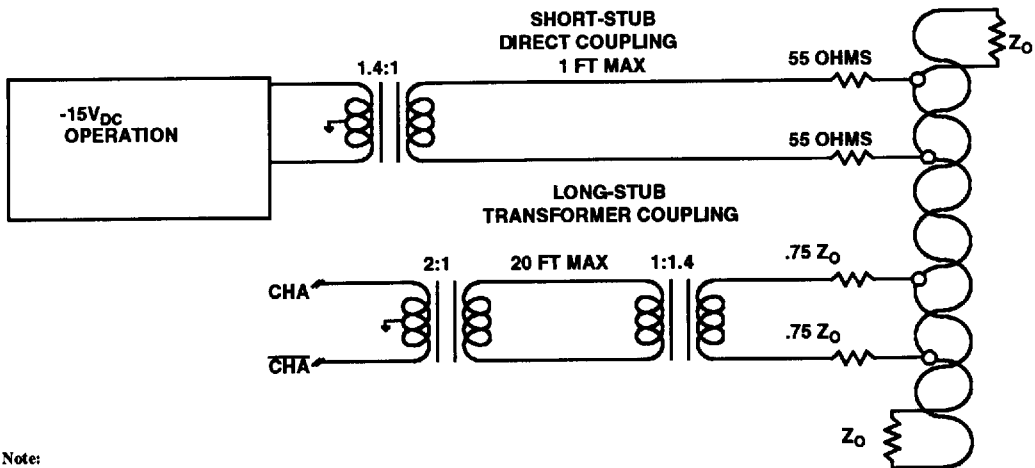
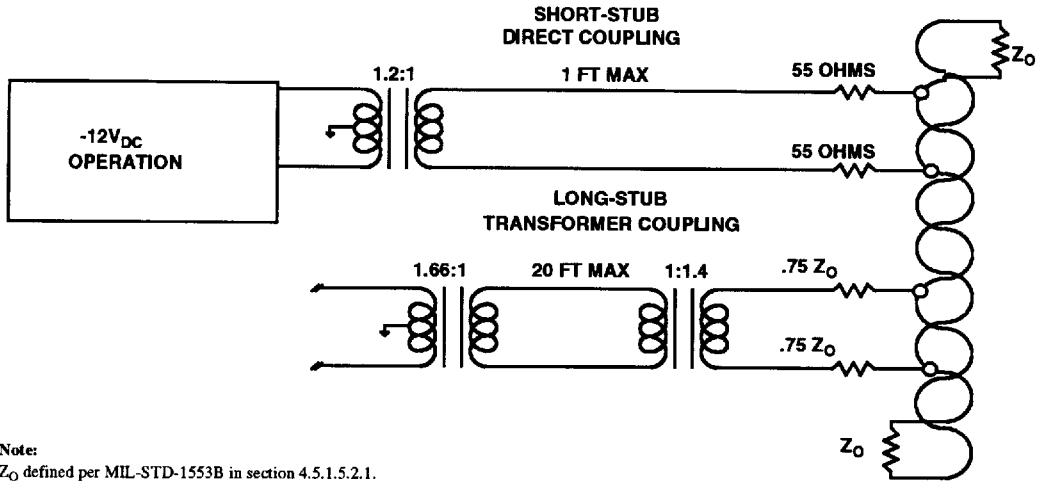
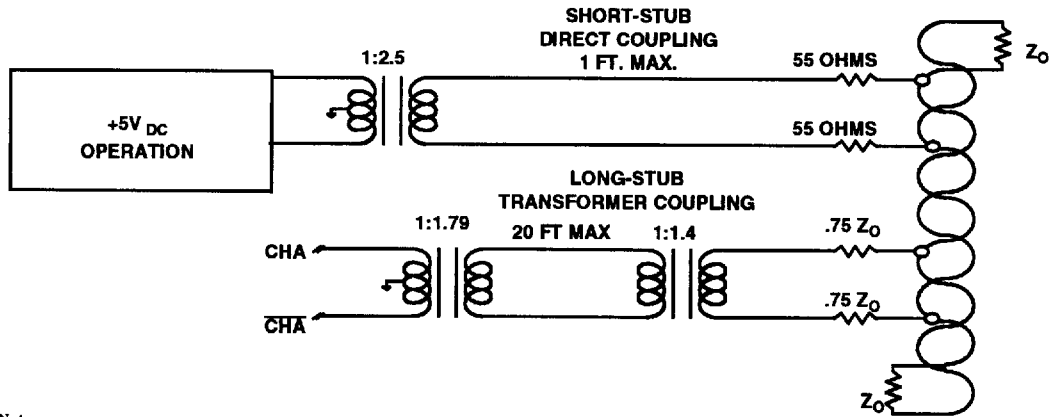

Figure 29a. S μ MMIT LX15, XT15 Bus Coupling Configuration



Note:
Z₀ defined per MIL-STD-1553B in section 4.5.1.5.2.1.

Figure 29b. SμMMIT LX12, XT12 Bus Coupling Configuration



Note:
Z₀ defined per MIL-STD-1553B in section 4.5.1.5.2.1.

Figure 29c. SμMMIT DX, XT5 Bus Coupling Configuration

Table 19. Transformer Requirements Versus Power Supplies

COUPLING TECHNIQUE	-12V_{DC}	-15V_{DC}	+5V_{DC}
DIRECT-COUPLED: Isolation	1.2:1	1.4:1	1:2.5
TRANSFORMER-COUPLED: Isolation Transformer Ratio	1.66:1	2:1	1:1.79
Coupling Transformer Ratio	1:1.4	1:1.4	1:1.4

11.0 S μ MMIT PIN IDENTIFICATION AND DESCRIPTION

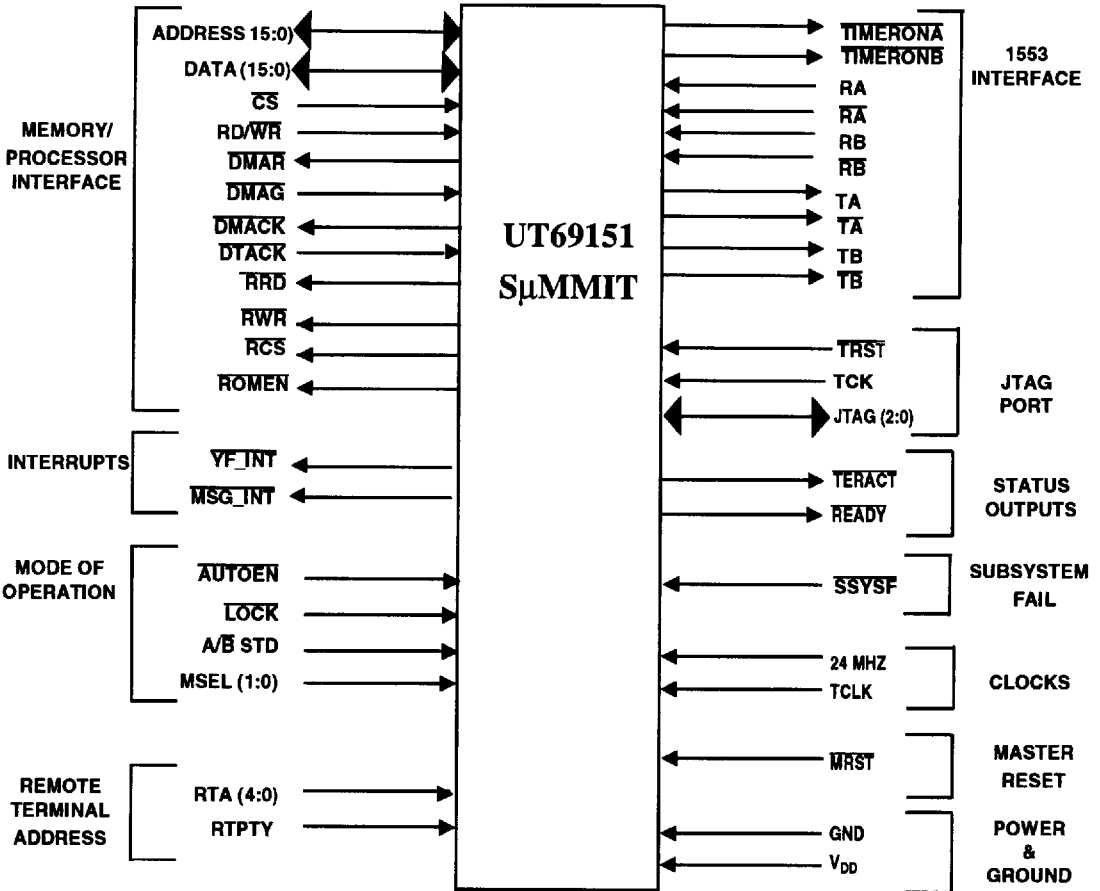

Figure 30. S μ MMIT Functional Pin Description

11.1 SμMMIT Functional Pin Description

Legend for TYPE and ACTIVE fields:

- TO = TTL output
- TTB = Three-state TTL bidirectional
- CI = CMOS input
- TUI = TTL input (internally pulled high)
- AH = Active high
- AL = Active low
- TI = TTL input
- TTO = Three-state TTL output
- PGA = Pingrid Array
- FP = Flatpack
- [] = 132-lead Flatpack

11.1.1 Data Bus

Bit Number	Type	Active	Pin Number		Description
			FP	PGA	
15	TTB	--	4 [7]	C1	Bit 15 (MSB) of the bidirectional Data bus.
14	TTB	--	5 [8]	D2	Bit 14 of the bidirectional Data bus.
13	TTB	--	6 [9]	D1	Bit 13 of the bidirectional Data bus.
12	TTB	--	7 [10]	F2	Bit 12 of the bidirectional Data bus.
11	TTB	--	8 [11]	E2	Bit 11 of the bidirectional Data bus.
10	TTB	--	9 [15]	E1	Bit 10 of the bidirectional Data bus.
9	TTB	--	10 [18]	F1	Bit 9 of the bidirectional Data bus.
8	TTB	--	13 [19]	G1	Bit 8 of the bidirectional Data bus.
7	TTB	--	14 [20]	G2	Bit 7 of the bidirectional Data bus.
6	TTB	--	15 [24]	G3	Bit 6 of the bidirectional Data bus.
5	TTB	--	16 [25]	H1	Bit 5 of the bidirectional Data bus.
4	TTB	--	17 [26]	H2	Bit 4 of the bidirectional Data bus.
3	TTB	--	18 [27]	J1	Bit 3 of the bidirectional Data bus.
2	TTB	--	19 [30]	K1	Bit 2 of the bidirectional Data bus.
1	TTB	--	20 [31]	J2	Bit 1 of the bidirectional Data bus.
0	TTB	--	21 [32]	L1	Bit 0 (LSB) of the bidirectional Data bus.

11.1.2 Address Bus

Bit Number	Type	Active	Pin Number		Description
			FP	PGA	
15	TTO	--	64 [101]	B10	Bit 15 (MSB) of the Address bus.
14	TTO	--	65 [102]	B9	Bit 14 of the Address bus.
13	TTO	--	66 [103]	A10	Bit 13 of the Address bus.
12	TTO	--	67 [106]	A9	Bit 12 of the Address bus.
11	TTO	--	68 [107]	B8	Bit 11 of the Address bus.
10	TTO	--	69 [108]	A8	Bit 10 of the Address bus.
9	TTO	--	70 [109]	C7	Bit 9 of the Address bus.
8	TTO	--	71 [110]	B7	Bit 8 of the Address bus.
7	TTO	--	72 [114]	A7	Bit 7 of the Address bus.
6	TTO	--	76 [118]	A5	Bit 6 of the Address bus.
5	TTO	--	77 [119]	B5	Bit 5 of the Address bus.
4	TTB	--	78 [123]	A6	Bit 4 of the bidirectional Address bus.
3	TTB	--	79 [124]	A4	Bit 3 of the bidirectional Address bus.
2	TTB	--	80 [125]	B4	Bit 2 of the bidirectional Address bus.
1	TTB	--	81 [126]	A3	Bit 1 of the bidirectional Address bus.
0	TTB	--	82 [129]	A2	Bit 0 (LSB) of the bidirectional Address bus.

11.1.3 Remote Terminal Address Inputs

Name	Type	Active	Pin Number		Description
			FP	PGA	
RTA4	TUI	--	37 [58]	L8	Remote terminal Address Bit 4. This is the most significant bit for the RT address.
RTA3	TUI	--	38 [59]	K8	Remote Terminal Address Bit 3. This is bit 3 of the RT address.
RTA2	TUI	--	39 [60]	L9	Remote Terminal Address bit 2. This is bit 2 of the RT address.
RTA1	TUI	--	40 [63]	L10	Remote Terminal Address Bit 1. This is bit 1 of the RT address.
RTA0	TUI	--	41 [64]	K9	Remote Terminal Address Bit 0. This is bit 0 of the RT address. This is the least significant bit for the RT address.
RTPTY	TUI	--	42 [64]	L11	Remote Terminal Parity. This is an odd parity input for the RT address.

11.1.4 JTAG Testability Pins

Name	Type	Active	Pin Number		Description
			FP	PGA	
TDO	TTO	--	49 [79]	G9	TDO. This output performs the operation of Test Data Output as defined in the IEEE Standard 1149.1. This non-inverting output buffer is optimized for driving TTL loads.
TCK	TI	--	54 [84]	E9	TCK. This input performs the operation of Test Clock input as defined in the IEEE Standard 1149.1. This non-inverting input buffer is optimized for driving TTL input levels.
TMS	TUI	--	51 [81]	G11	TMS. This input performs the operation of Test Mode Select as defined in the IEEE Standard 1149.1. This non-inverting input buffer is optimized for driving TTL input levels.
TDI	TUI	--	50 [80]	G10	TDI. This input performs the operation of Test Data In as defined in the IEEE Standard 1149.1. This non-inverting input buffer is optimized for driving TTL input levels.
TRST	TUI	AL	48 [78]	H11	TRST. This input provides the RESET to the TAP controller as defined in the IEEE Standard 1149.1. This non-inverting input buffer is optimized for driving TTL input levels. When not exercising JTAG, tie TRST to a logical 0.

11.1.5 Biphase Inputs

Name	Type	Active	Pin Number		Description
			FP	PGA	
RA	TI	--	26 [41]	K4	Receive Channel A (True). This is the Manchester-encoded true signal input for channel A. (Quiescent low).
RA	TI	--	25 [38]	L3	Receive Channel A (Complement). This is the Manchester-encoded complement signal input for channel A. (Quiescent low).
RB	TI	--	33 [51]	J5	Receive Channel B (True). This is the Manchester-encoded true signal input for channel B. (Quiescent low).
RB	TI	--	30 [48]	L5	Receive Channel B (Complement). This is the Manchester-encoded complement signal input for channel B. (Quiescent low).

11.1.6 Biphase Outputs

Name	Type	Active	Pin Number		Description
			FP	PGA	
TA	TO	--	24 [37]	L2	Transmit Channel A (True). This is the Manchester-encoded true signal output for channel A. The signal is idle low. (Quiescent low).
TA	TO	--	23 [36]	K3	Transmit Channel A (Complement). This is the Manchester-encoded complement signal output for channel A. The signal is idle low. (Quiescent low).
TB	TO	--	29 [44]	K5	Transmit Channel B (True). This is the Manchester-encoded true signal output for channel B. The signal is idle low. (Quiescent low).
TB	TO	--	28 [43]	K6	Transmit Channel B (Complement). This is the Manchester-encoded complement signal output for channel B. The signal is idle low. (Quiescent low).

11.1.7 DMA Signals

Name	Type	Active	Pin Number		Description
			FP	PGA	
DMAR	TTO ¹	AL	55 [85]	E11	DMA Request. This signal is asserted when access to RAM is required. It goes inactive upon receipt of the DMAG signal.
DMAG	TI	AL	56 [86]	E10	DMA Grant. Once this input is received, the SμMMIT is allowed to access RAM.
DMACK	TTO ¹	AL	57 [90]	F11	DMA Acknowledge. This signal is asserted by the SμMMIT to indicate the receipt of DMAG. The signal remains active until all RAM bus activity is completed.
DTACK	TI	AL	3 [4]	B1	Data Transfer Acknowledge. This pin indicates that a data transfer is to occur and that the SμMMIT may complete the memory cycle.

Note:

Open drain outputs; high impedance and active low.

11.1.8 Control Signals

Name	Type	Active	Pin Number		Description															
			FP	PGA																
RD/WR	TI	--	63 [98]	A11	Read/Write. This indicates the direction of data flow with respect to the host. A logic high signal means the host is trying to read data from the μ MMIT, and a logic low signal means the host is trying to write data to the μ MMIT.															
CS	TI	AL	62 [97]	C10	Chip Select. This pin selects the μ MMIT when accessing the internal registers.															
RRD	TTO	AL	84 [131]	A1	RAM Read. This signal is generated by the μ MMIT to read data from RAM.															
RWR	TTO	AL	83 [130]	B3	RAM Write. This signal is generated by the μ MMIT to write data to RAM.															
RCS	TTO	AL	1 [2]	B2	RAM Chip Select. This signal is used in conjunction with the RRD/RWR signals to access RAM.															
AUTOEN	TI	AL	60 [93]	C11	Auto Enable. This pin, when active, enables automatic initialization.															
ROMEN	TTO ¹	AL	61 [96]	B11	ROM Enable. This pin, when active, enables the ROM for automatic initialization applications.															
SSYSF	TI	AL	36 [57]	J7	Subsystem Fail. Upon receipt, this signal propagates directly to the RT 1553 Status Word.															
24 MHz	CI	--	75 [117]	C5	24 MHz Clock. The 24MHz input clock requires a 50% \pm 5% duty cycle with an accuracy of \pm 0.01%. See Appendix A on UT54ACTS220 Clock Generator.															
MRST	TUI	AL	47 [75]	H10	Master Reset. This input pin resets the internal encoders, decoders, all registers, and associated logic.															
MSEL(1)	TI	--	45 [73]	K11	Mode Select 1. This pin is the most significant bit for the mode select. For proper mode selection, see below: <table style="margin-left: 40px; border: none;"> <tr> <td>MSEL(1)</td> <td>MSEL(0)</td> <td>Mode of Operation</td> </tr> <tr> <td>0</td> <td>0</td> <td>Bus Controller = SBC</td> </tr> <tr> <td>0</td> <td>1</td> <td>Remote Terminal = SRT</td> </tr> <tr> <td>1</td> <td>0</td> <td>Monitor Terminal = SMT</td> </tr> <tr> <td>1</td> <td>1</td> <td>SMT/SRT</td> </tr> </table>	MSEL(1)	MSEL(0)	Mode of Operation	0	0	Bus Controller = SBC	0	1	Remote Terminal = SRT	1	0	Monitor Terminal = SMT	1	1	SMT/SRT
MSEL(1)	MSEL(0)	Mode of Operation																		
0	0	Bus Controller = SBC																		
0	1	Remote Terminal = SRT																		
1	0	Monitor Terminal = SMT																		
1	1	SMT/SRT																		
MSEL(0)	TI	--	46 [74]	J11	Mode Select 0. This pin is the least significant bit for the mode select. (See MSEL1 for proper logic states.)															

11.1.8 Control Signals (continued)

Name	Type	Active	Pin Number		Description
			FP	PGA	
TCLK	TI	--	2 [3]	C2	Timer Clock. The internal timer is a 16-bit counter with a 64 μ s resolution when using the 24MHz input clock. For different applications, the user may input a clock (0-6MHz) to establish the timer resolution. (Duty Cycle = 50% \pm 10%).
A/B STD	TI	--	44 [69]	J10	Military Standard A or B. This pin defines whether the S μ MMIT will be used in a MIL-STD-1553A or 1553B mode of operation.
LOCK	TI	AL	43 [68]	K10	Lock. This pin, when set active, prevents software changes to both the RT address, A/B STD, and mode select.

Note:

Open drain outputs; high impedance and active low.

11.1.9 Status Signals

Name	Type	Active	Pin Number		Description
			FP	PGA	
TERACT	TO	AL	34 [52]	L7	Terminal Active. This output pin indicates that the terminal is actively processing a 1553 command.
TIMER ONA	TO	AL	22 [35]	K2	Timer On A. This is a 800 μ s fail-safe transmitter enable timer for channel A. This output is reset on receipt of a new command or after 760 μ s.
TIMER ONB	TO	AL	27 [42]	L4	Timer On B. This is a 800 μ s fail-safe transmitter enable timer for channel B. This output is reset on receipt of a new command or after 760ms.
MSG_INT	TTO ¹	AL	58 [91]	D11	Message Interrupt. This pin is active for three clock cycles (i.e., 125ns pulse) upon the occurrence of interrupt events which are enabled.
YF_INT	TTO ¹	AL	59 [92]	D10	You Failed Interrupt. This pin is active for three clock cycles (i.e., 125ns pulse) upon the occurrence of interrupt events which are enabled.
READY	TO	AL	35 [53]	K7	Ready. This signal indicates the S μ MMIT has completed initialization or BIT, and regular execution may begin.

Note:

Open drain outputs; high impedance and active low.

11.1.10 Power/Ground

The following shows the package location of all power and ground pins associated with the S μ MMIT.

Pin Number	Pin Number		Description
	FP	PGA	
V _{DD}	12, 32, 53, 73 [17], [34], [50], [66], [83], [100], [115], [132]	E3, L6, F9, C6	+5 Volt Power (\pm 10%)
V _{SS}	11, 31, 52, 74 [1], [16], [33], [49], [67], [82], [99], [116]	F3, J6, F10, B6	Digital Ground

12.0 SμMMIT LX/DX PIN IDENTIFICATION AND DESCRIPTION

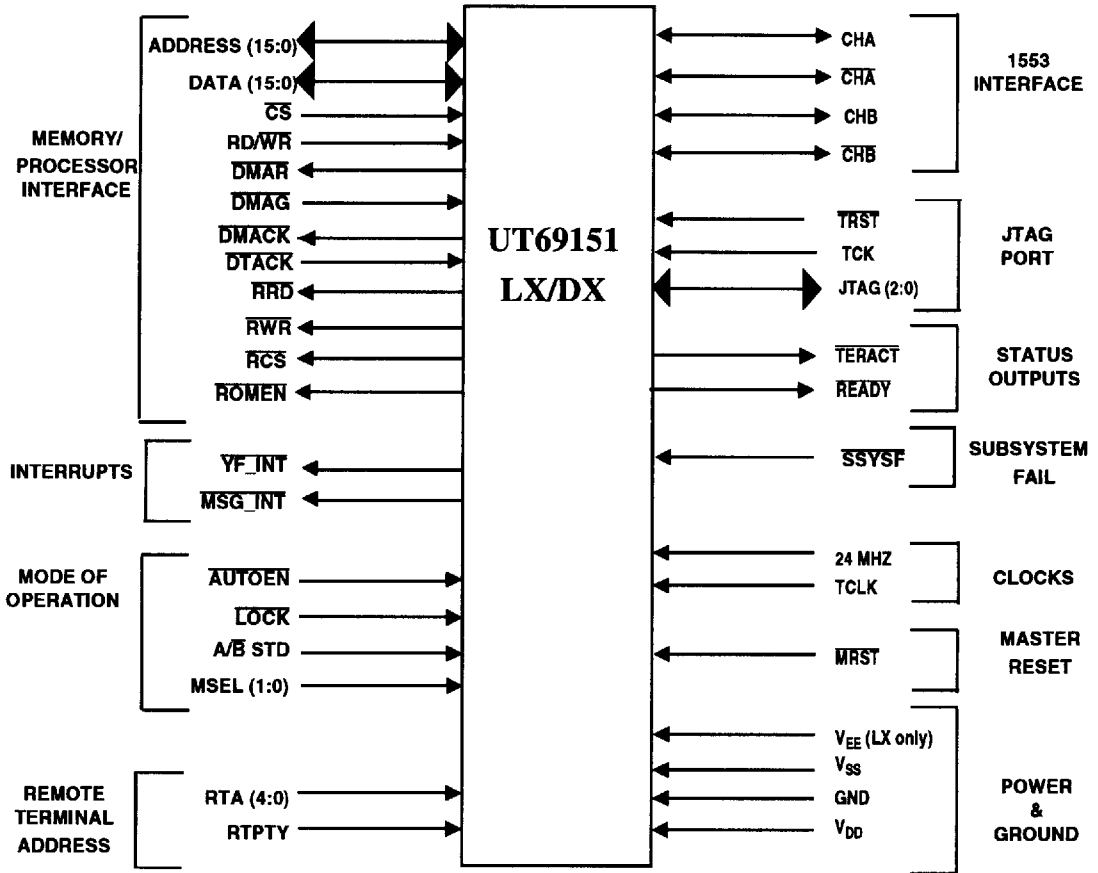

Figure 31. SμMMIT LX/DX Functional Pin Description

12.1 μ MMIT LX/DX Pin Functional Description

Legend for TYPE and ACTIVE fields:

TO = TTL output
 TTB = Three-state TTL bidirectional
 CI = CMOS input
 TUI = TTL input (internally pulled high)
 AH = Active high
 AL = Active low
 TI = TTL input
 TTO = Three-state TTL output
 PGA = Pingrid Array
 FP = Flatpack
 DIO = Differential input/output

12.1.1 Data Bus

Bit Number	Type	Active	Pin Number		Description
			FP	PGA	
15	TTB	--	97	V11	Bit 15 (MSB) of the bidirectional Data bus.
14	TTB	--	96	V5	Bit 14 of the bidirectional Data bus.
13	TTB	--	95	V9	Bit 13 of the bidirectional Data bus.
12	TTB	--	94	U10	Bit 12 of the bidirectional Data bus.
11	TTB	--	93	U12	Bit 11 of the bidirectional Data bus.
10	TTB	--	92	V15	Bit 10 of the bidirectional Data bus.
9	TTB	--	91	V13	Bit 9 of the bidirectional Data bus.
8	TTB	--	90	V17	Bit 8 of the bidirectional Data bus.
7	TTB	--	89	W18	Bit 7 of the bidirectional Data bus.
6	TTB	--	88	W16	Bit 6 of the bidirectional Data bus.
5	TTB	--	87	W14	Bit 5 of the bidirectional Data bus.
4	TTB	--	86	W20	Bit 4 of the bidirectional Data bus.
3	TTB	--	85	W22	Bit 3 of the bidirectional Data bus.
2	TTB	--	84	V21	Bit 2 of the bidirectional Data bus.
1	TTB	--	83	V19	Bit 1 of the bidirectional Data bus.
0	TTB	--	82	V23	Bit 0 (LSB) of the bidirectional Data bus.

12.1.2 Address Bus

Bit Number	Type	Active	Pin Number		Description
			FP	PGA	
15	TTO	--	26	A2	Bit 15 (MSB) of the Address bus.
14	TTO	--	25	A4	Bit 14 of the Address bus.
13	TTO	--	24	A6	Bit 13 of the Address bus.
12	TTO	--	23	C2	Bit 12 of the Address bus.
11	TTO	--	22	B3	Bit 11 of the Address bus.
10	TTO	--	21	B5	Bit 10 of the Address bus.
9	TTO	--	20	D1	Bit 9 of the Address bus.
8	TTO	--	19	C6	Bit 8 of the Address bus.
7	TTO	--	18	D3	Bit 7 of the Address bus.
6	TTO	--	17	T7	Bit 6 of the Address bus.
5	TTO	--	16	W2	Bit 5 of the Address bus.
4	TTB	--	15	T3	Bit 4 of the bidirectional Address bus.
3	TTB	--	14	T1	Bit 3 of the bidirectional Address bus.
2	TTB	--	13	U6	Bit 2 of the bidirectional Address bus.
1	TTB	--	12	U2	Bit 1 of the bidirectional Address bus.
0	TTB	--	11	W6	Bit 0 (LSB) of the bidirectional Address bus.

12.1.3 Remote Terminal Address Inputs

Name	Type	Active	Pin Number		Description
			FP	PGA	
RTA4	TUI	--	59	B17	Remote terminal Address Bit 4. This is the most significant bit for the RT address.
RTA3	TUI	--	58	B19	Remote Terminal Address Bit 3. This is bit 3 of the RT address.
RTA2	TUI	--	57	A20	Remote Terminal Address bit 2. This is bit 2 of the RT address.
RTA1	TUI	--	56	B21	Remote Terminal Address Bit 1. This is bit 1 of the RT address.
RTA0	TUI	--	55	A22	Remote Terminal Address Bit 0. This is bit 0 of the RT address. This is the least significant bit for the RT address.
RTPTY	TUI	--	54	B23	Remote Terminal Parity. This is an odd parity input for the RT address.

12.1.4 JTAG Testability Pins

Name	Type	Active	Pin Number		Description
			FP	PGA	
TDO	TTO	--	52	A18	TDO. This output performs the operation of Test Data Output as defined in the IEEE Standard 1149.1. This non-inverting output buffer is optimized for driving TTL loads.
TCK	TI	--	49	A14	TCK. This input performs the operation of Test Clock input as defined in the IEEE Standard 1149.1. This non-inverting input buffer is optimized for driving TTL input levels.
TMS	TUI	--	50	C14	TMS. This input performs the operation of Test Mode Select as defined in the IEEE Standard 1149.1. This non-inverting input buffer is optimized for driving TTL input levels.
TDI	TUI	--	51	A16	TDI. This input performs the operation of Test Data In as defined in the IEEE Standard 1149.1. This non-inverting input buffer is optimized for driving TTL input levels.
TRST	TUI	AL	53	B15	TRST. This input provides the RESET to the TAP controller as defined in the IEEE Standard 1149.1. This non-inverting input buffer is optimized for driving TTL input levels. When not exercising JTAG, tie TRST to a logical 0.

12.1.5 Biphase Inputs/Outputs

Name	Type	Active	Pin Number		Description
			FP	PGA	
CHA	DIO	--	32	U22	Channel A (True). This is the Manchester-encoded true signal for channel A.
$\overline{\text{CHA}}$	DIO	--	33	U18	Channel A (Complement). This is the Manchester-encoded complement signal input for channel A.
CHB	DIO	--	42	C22	Channel B (True). This is the Manchester-encoded true signal for channel B.
$\overline{\text{CHB}}$	DIO	--	43	C18	Channel B (Complement). This is the Manchester-encoded complement signal for channel B.

12.1.6 DMA Signals

Name	Type	Active	Pin Number		Description
			FP	PGA	
DMAR	TTO ¹	AL	3	D13	DMA Request. This signal is asserted when access to RAM is required. It goes inactive upon receipt of the DMAG signal.
DMAG	TI	AL	2	C10	DMA Grant. Once this input is received, the SμMMIT LX/DX is allowed to access RAM.
DMACK	TTO ¹	AL	1	B7	DMA Acknowledge. This signal is asserted by the SμMMIT LX/DX to indicate the receipt of DMAG. The signal remains active until all RAM bus activity is completed.
DTACK	TI	AL	4	V7	Data Transfer Acknowledge. This pin indicates that a data transfer is to occur and that the SμMMIT LX/DX may complete the memory cycle.

Note:

1. Open drain outputs; high impedance and active low.

12.1.7 Control Signals

Name	Type	Active	Pin Number		Description															
			FP	PGA																
RD/WR	TI	--	81	B11	Read/Write. This indicates the direction of data flow with respect to the host. A logic high signal means the host is trying to read data from the SμMMIT LX/DX, and a logic low signal means the host is trying to write data to the SμMMIT LX/DX.															
CS	TI	AL	80	A10	Chip Select. This pin selects the SμMMIT LX/DX when accessing the internal registers.															
RRD	TTO	AL	6	V3	RAM Read. This signal is generated by the SμMMIT LX/DX to read data from RAM.															
RWR	TTO	AL	7	W4	RAM Write. This signal is generated by the SμMMIT LX/DX to write data to RAM.															
RCS	TTO	AL	8	W12	RAM Chip Select. This signal is used in conjunction with the RRD/RWR signals to access RAM.															
AUTOEN	TI	AL	79	B9	Auto Enable. This pin, when active, enables automatic initialization.															
ROMEN	TTO ¹	AL	78	A8	ROM Enable. This pin, when active, enables the ROM for automatic initialization applications.															
SSYSF	TI	AL	75	U14	Subsystem Fail. Upon receipt, this signal propagates directly to the RT 1553 Status Word.															
24 MHz	CI	--	74	T9	24 MHz Clock. The 24MHz input clock requires a 50% ± 5% duty cycle with an accuracy of ±0.01%. See appendix 2 on UT54ACTS220 Clock Generator.															
MRST	TUI	AL	73	D15	Master Reset. This input pin resets the internal encoders, decoders, all registers, and associated logic.															
MSEL(1)	TI	--	72	B13	Mode Select 1. This pin is the most significant bit for the mode select. For proper mode selection, see below: <table style="margin-left: 40px; border: none;"> <tr> <td>MSEL(1)</td> <td>MSEL(0)</td> <td>Mode of Operation</td> </tr> <tr> <td>0</td> <td>0</td> <td>Bus Controller = SBC</td> </tr> <tr> <td>0</td> <td>1</td> <td>Remote Terminal = SRT</td> </tr> <tr> <td>1</td> <td>0</td> <td>Monitor Terminal = SMT</td> </tr> <tr> <td>1</td> <td>1</td> <td>SMT/SRT</td> </tr> </table>	MSEL(1)	MSEL(0)	Mode of Operation	0	0	Bus Controller = SBC	0	1	Remote Terminal = SRT	1	0	Monitor Terminal = SMT	1	1	SMT/SRT
MSEL(1)	MSEL(0)	Mode of Operation																		
0	0	Bus Controller = SBC																		
0	1	Remote Terminal = SRT																		
1	0	Monitor Terminal = SMT																		
1	1	SMT/SRT																		
MSEL(0)	TI	--	71	A12	Mode Select 0. This pin is the least significant bit for the mode select. (See MSEL1 for proper logic states.)															

Name	Type	Active	Pin Number		Description
			FP	PGA	
TCLK	TI	--	68	W8	Timer Clock. The internal timer is a 16-bit counter with a 64 μ s resolution when using the 24MHz input clock. For different applications, the user may input a clock (0-6MHz) to establish the timer resolution. (Duty Cycle = 50% \pm 10%).
A/B STD	TI	--	70	C16	Military Standard A or B. This pin defines whether the S μ MMIT LX/DX will be used in a MIL-STD-1553A or 1553B mode of operation.
LOCK	TI	AL	69	T13	Lock. This pin, when set active, prevents software changes to both the RT address, A/B STD, and mode select.

Note:

1. Open drain outputs; high impedance and active low.

12.1.8 Status Signals

Name	Type	Active	Pin Number		Description
			FP	PGA	
TERACT	TO	AL	63	U16	Terminal Active. This output pin indicates that the terminal is actively processing a 1553 command.
MSG_INT	TTO ¹	AL	65	D9	Message Interrupt. This pin is active for three clock cycles (i.e., 125ns pulse) upon the occurrence of interrupt events which are enabled.
YF_INT	TTO ¹	AL	66	C12	You Failed Interrupt. This pin is active for three clock cycles (i.e., 125ns pulse) upon the occurrence of interrupt events which are enabled.
READY	TO	AL	64	T15	Ready. This signal indicates the S μ MMIT LX/DX has completed initialization or BIT, and regular execution may begin.

Note:

1. Open drain outputs; high impedance and active low.

12.1.9 Power/Ground

The following shows the package location of all power and ground pins associated with the μ MMIT LXDX.

Pin Number	Pin Number		Description
	FP	PGA	
V _{DD}	9, 60, 62, 76, 99, 100	C4, U4, B1, D7, T5, W10	+5 Volt Logic Power ($\pm 10\%$)
V _{CC}	30, 35, 36, 39, 40, 45	D19, T19, C24, U24	LX: +5 Volt Transceiver Power (+10%, -5%) Recommended de-coupling capacitors: 4.7 μ F and .1 μ F DX: +5 Volt Transceiver Power ($\pm 10\%$) Recommended de-coupling capacitors: 4.7 μ F and .1 μ F
V _{EE}	27, 28, 47, 48	T21, T23, D21, D23 (LX only)	-12 or -15 Volt Transceiver Power ($\pm 5\%$) Recommended de-coupling capacitors: 4.7 μ F and .1 μ F
V _{SS}	5, 10, 61, 67, 77, 98	C8, U8, D5, D11, T11, V1	Digital Ground
GND	29, 31, 34, 37, 38, 41, 44, 46	T17, U20, W24, D17, C20, A24	Transceiver Ground

13.0 SμMMIT XT PIN IDENTIFICATION AND DESCRIPTION

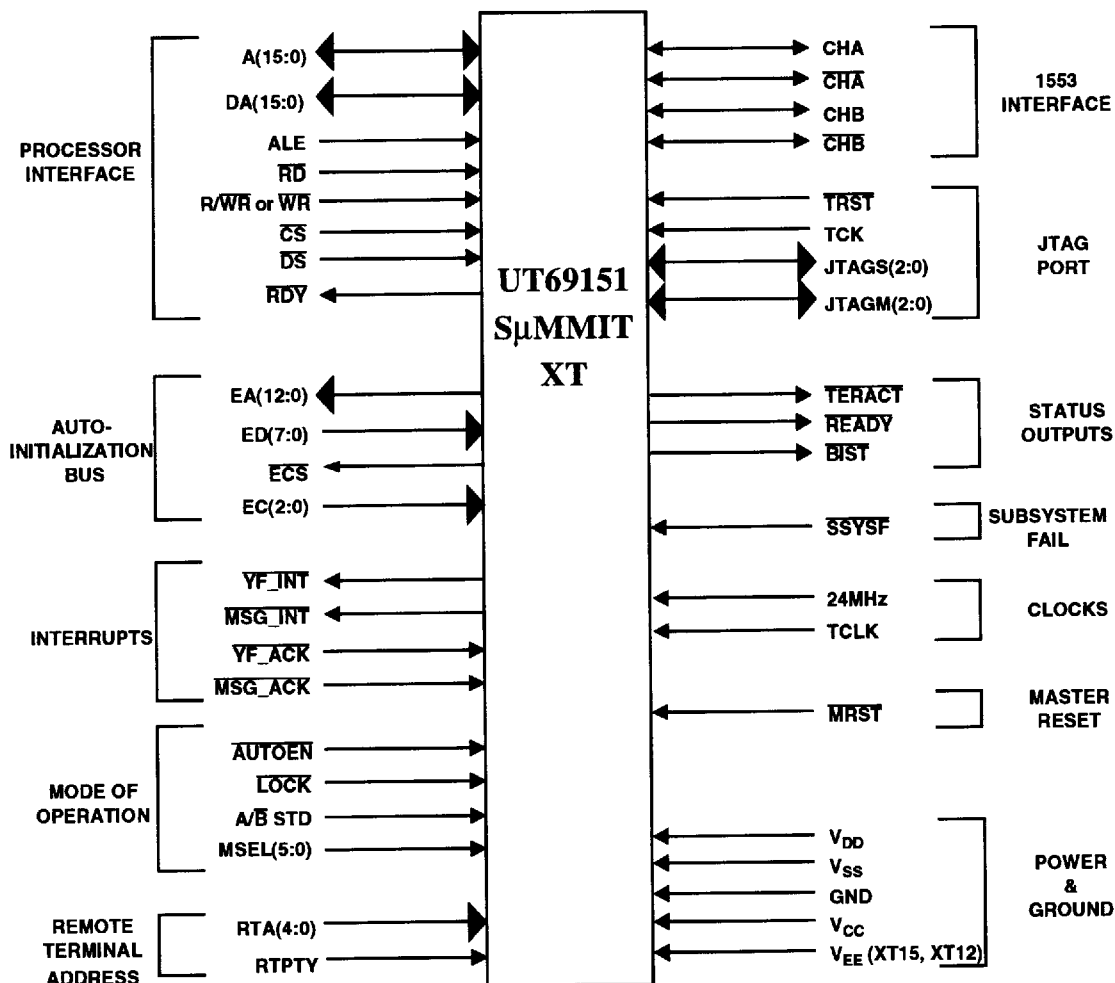

Figure 32. SμMMIT XT Functional Pin Diagram

13.1 ΣμMMIT Functional Pin Description

Legend for TYPE and ACTIVE fields:

- TO = TTL output
- TTB = Three-state TTL bidirectional
- CI = CMOS input
- TUI = TTL input (internally pulled high)
- AH = Active high
- AL = Active low
- TI = TTL input
- TTO = Three-state TTL output
- PGA = Pingrid Array
- FP = Flatpack
- DIO = Differential input/output

13.1.1 Data Bus DA (15:0)

Bit Number	Type	Active	Pin Number		Description
			FP	PGA	
15	TTB	--	17	N11	Bit 15 (MSB) of the bidirectional Data bus.
14	TTB	--	18	L10	Bit 14 of the bidirectional Data bus.
13	TTB	--	19	M11	Bit 13 of the bidirectional Data bus.
12	TTB	--	20	L11	Bit 12 of the bidirectional Data bus.
11	TTB	--	21	N12	Bit 11 of the bidirectional Data bus.
10	TTB	--	22	M12	Bit 10 of the bidirectional Data bus.
9	TTB	--	23	L12	Bit 9 of the bidirectional Data bus.
8	TTB	--	24	L13	Bit 8 of the bidirectional Data bus.
7	TTB	--	25	M13	Bit 7 of the bidirectional Data bus.
6	TTB	--	26	L14	Bit 6 of the bidirectional Data bus.
5	TTB	--	28	K11	Bit 5 of the bidirectional Data bus.
4	TTB	--	29	K13	Bit 4 of the bidirectional Data bus.
3	TTB	--	30	K12	Bit 3 of the bidirectional Data bus.
2	TTB	--	31	J11	Bit 2 of the bidirectional Data bus.
1	TTB	--	32	J12	Bit 1 of the bidirectional Data bus.
0	TTB	--	33	J13	Bit 0 (LSB) of the bidirectional Data bus.

13.1.2 Address Bus A(15:0)

Bit Number	Type	Active	Pin Number		Description
			FP	PGA	
15	TI	--	38	J14	Bit 15 (MSB) of the Address bus.
14	TI	--	39	H11	Bit 14 of the Address bus.
13	TI	--	40	H12	Bit 13 of the Address bus.
12	TI	--	41	H13	Bit 12 of the Address bus.
11	TI	--	42	G11	Bit 11 of the Address bus.
10	TI	--	43	G12	Bit 10 of the Address bus.
9	TI	--	45	G13	Bit 9 of the Address bus.
8	TI	--	46	G14	Bit 8 of the Address bus.
7	TI	--	47	F11	Bit 7 of the Address bus.
6	TI	--	48	F12	Bit 6 of the Address bus.
5	TI	--	49	F13	Bit 5 of the Address bus.
4	TI	--	50	D13	Bit 4 of the Address bus.
3	TI	--	51	E13	Bit 3 of the Address bus.
2	TI	--	52	C13	Bit 2 of the Address bus.
1	TI	--	54	E14	Bit 1 of the Address bus.
0	TI	--	55	C14	Bit 0 (LSB) of the Address bus.

13.1.3 Auto-initialization Address Bus EA(12:0)

Bit Number	Type	Active	Pin Number		Description
			FP	PGA	
12	TO	--	85	F9	Bit 12 (MSB) of the auto-init Address bus.
11	TO	--	84	F10	Bit 11 of the auto-init Address bus.
10	TO	--	83	G10	Bit 10 of the auto-init Address bus.
9	TO	--	82	C11	Bit 9 of the auto-init Address bus.
8	TO	--	81	G9	Bit 8 of the auto-init Address bus.
7	TO	--	80	E11	Bit 7 of the auto-init Address bus.
6	TO	--	79	E10	Bit 6 of the auto-init Address bus.
5	TO	--	78	E9	Bit 5 of the auto-init Address bus.
4	TO	--	77	G8	Bit 4 of the auto-init Address bus.
3	TO	--	76	H8	Bit 3 of the auto-init Address bus.
2	TO	--	75	J7	Bit 2 of the auto-init Address bus.
1	TO	--	74	J9	Bit 1 of the auto-init Address bus.
0	TO	--	73	J10	Bit 0 (LSB) of the auto-init Address bus.

13.1.4 Auto-initialization Data Bus ED(7:0)

Bit Number	Type	Active	Pin Number		Description
			FP	PGA	
7	TUI	--	68	K10	Bit 7 (MSB) of the auto-init data.
6	TUI	--	67	M7	Bit 6 of the auto-init data.
5	TUI	--	66	N3	Bit 5 of the auto-init data.
4	TUI	--	65	N8	Bit 4 of the auto-init data.
3	TUI	--	64	M8	Bit 3 of the auto-init data.
2	TUI	--	63	L8	Bit 2 of the auto-init data.
1	TUI	--	62	N9	Bit 1 of the auto-init data.
0	TUI	--	61	M9	Bit 0 (LSB) of the auto-init data.

13.1.5 Remote Terminal Address Inputs

Name	Type	Active	Pin Number		Description
			FP	PGA	
RTA4	TUI	--	115	E2	Remote Terminal Address 4. This is the most significant bit for the RT address.
RTA3	TUI	--	116	G3	Remote Terminal Address 3. This is bit 3 of the RT address.
RTA2	TUI	--	117	F3	Remote Terminal Address 2. This is bit 2 of the RT address.
RTA1	TUI	--	118	G2	Remote Terminal Address 1. This is bit 1 of the RT address.
RTA0	TUI	--	119	F2	Remote Terminal Address 0. This input is the least significant bit of the RT address.
RTPTY	TUI	--	120	G1	Remote Terminal Parity. This is an odd parity input for the RT address.

13.1.6 JTAG Testability Pins

Name	Type	Active	Pin Number		Description
			FP	PGA	
TDOM	TTO	--	59	N10	Memory Management Unit (MMU) TDO. This input performs the operation of Test Data Output as defined in IEEE Standard 1149.1.
TDIM	TUI	--	58	L9	MMU TDI. This input performs the operation of Test Data Input as defined in IEEE Standard 1149.1.
TMSM	TUI	--	57	M10	MMU TMS. This input performs the operation of Test Mode Select as defined in IEEE Standard 1149.1.
TDOS	TTO	--	134	K3	S μ MMIT TDO. This input performs the operation of Test Data Output as defined in IEEE Standard 1149.1.
TDIS	TUI	--	135	K2	S μ MMIT TDI. This input performs the operation of Test Data Input as defined in IEEE Standard 1149.1.
TMSS	TUI	--	136	J2	S μ MMIT TMS. This input performs the operation of Test Mode Select as defined in IEEE Standard 1149.1.
TCK	TI	--	137	L2	TCK. This input performs the operation of Test Clock as defined in IEEE Standard 1149.1.
TRST	TUI	AL	133	L3	TRST. This input provides the RESET to the TAP controller as defined in the IEEE Standard 1149.1. This non-inverting input buffer is optimized for driving TTL input levels. When not exercising JTAG, tie TRST to a logical 0.

13.1.7 Biphase Inputs/Outputs

Name	Type	Active	Pin Number		Description
			FP	PGA	
CHA	DIO	--	92	B7	Channel A (True). This is the Manchester-encoded true signal for Channel A.
$\overline{\text{CHA}}$	DIO	--	93	A7	Channel A (Complement). This is the Manchester-encoded complement signal for Channel A.
CHB	DIO	--	102	A3	Channel B (True). This is the Manchester-encoded true signal for Channel B.
$\overline{\text{CHB}}$	DIO	--	103	A2	Channel B (Complement). This is the Manchester-encoded complement signal for Channel B.

13.1.8 Control Signals

Name	Type	Active	Pin Number FP	PGA	Description												
CS	TI	AL	14	A10	Chip Select. This pin selects the μ MMIT XT's internal memory and registers.												
DS	TI	AL	12	A12	Data Strobe. During a write cycle, assert DS to indicate that data is valid on the data bus. During a read cycle assert DS to signal the μ MMIT XT to drive the data bus.												
RD	TI	AL	10	K8	Read Strobe. During a read cycle, assert RD to signal the μ MMIT XT to drive the data bus.												
R/WR or WR	TI	--	11	K7	Read/Write or Write Strobe. During a write cycle assert WR to signal the μ MMIT XT that data is valid on the data bus. R/WR indicates the direction of data flow with respect to the μ MMIT XT. R/WR high indicates the μ MMIT XT will drive the data bus. R/WR low indicates an outside source will drive the data bus.												
MSEL(5)	TUI	--	124	D12	Mode Select 5. A logical zero enables the μ MMIT XT's 16-bit interface. A logical one enables the 8-bit interface. Latched on the rising edge of MRST.												
MSEL(4)	TUI	--	125	B13	Mode Select 4. A logical zero enables a pulsed interrupt output. A logical one enables a level interrupt output. Latched on the rising edge of MRST.												
MSEL(3)	TUI	--	126	C12	Mode Select 3. A logical zero enables the μ MMIT XT's multiplexed address and data bus interface. A logical one enables the non-multiplexed interface. Latched on the rising edge of MRST.												
MSEL(2)	TUI	--	127	A11	Mode Select 2. A logical zero selects control signals RD, WR, CS, DS, and RDY. A logical one selects control signals R/WR, CS, DS, and RDY. Latched on the rising edge of MRST.												
MSEL(1)	TI	--	128	J3	Mode Select 1. This pin in conjunction with MSEL(0) selects the μ MMIT XT's mode of operation. Latched on the rising edge of MRST. <table border="1" style="margin-left: auto; margin-right: auto;"> <thead> <tr> <th>MSEL(1)</th> <th>MSEL(0)</th> <th>Mode of Operation</th> </tr> </thead> <tbody> <tr> <td>0</td> <td>0</td> <td>Bus Controller</td> </tr> <tr> <td>0</td> <td>1</td> <td>Remote Terminal</td> </tr> <tr> <td>1</td> <td>1</td> <td>Remote Terminal & Monitor</td> </tr> </tbody> </table>	MSEL(1)	MSEL(0)	Mode of Operation	0	0	Bus Controller	0	1	Remote Terminal	1	1	Remote Terminal & Monitor
MSEL(1)	MSEL(0)	Mode of Operation															
0	0	Bus Controller															
0	1	Remote Terminal															
1	1	Remote Terminal & Monitor															
MSEL(0)	TI	--	129	J1	Mode Select 0. This pin in conjunction with MSEL(1) selects the μ MMIT XT's mode of operation.												
EC(2)	TUI	--	97	B10	Latched on the rising edge of MRST this input sizes the auto-initialization cycle.												
EC(1)	TUI	--	98	D11	Latched on the rising edge of MRST this input sizes the auto-initialization cycle.												

Name	Type	Active	Pin Number		Description
			FP	PGA	
EC(0)	TUI	--	99	B12	Latched on the rising edge of MRST this input sizes the auto-initialization cycle.
24 MHz	CI	--	7	N7	24 MHz Clock. The 24MHz input clock requires a 50% ± 10% duty cycle with an accuracy of ± 0.01%.
MRST	TUI	AL	130	J8	Master Reset. This input pin resets the internal encoder, decoder, all registers, and associated logic.
ALE	TI	AH	13	E12	Address Latch Enable. The falling edge of this strobe latches address information into the S μ MMIT XT when operating with a multiplexed address and data bus.
TCLK	TI	--	138	L7	Timer Clock. The internal timer is a 16-bit counter with a 64 μ s resolution when using the 24MHz input clock. For applications requiring a different resolution, the user may input a clock from 0 to 6MHz to establish the timer resolution. (Duty cycle equals 50% ± 10%).
A/B STD	TUI	--	122	H2	A/B. Military Standard A or B. This pin defines whether the S μ MMIT XT operates per MIL-STD-1553A or MIL-STD-1553B. Input is latched on the rising edge of MRST .
LOCK	TUI	AL	121	H3	Lock. A logical zero applied to this pin prevents software from changing the RT address, A/B STD, or mode of operation. Input is latched on the rising edge of MRST .
AUTOEN	TUI	AL	131	M2	Auto Enable. When active this pin enables the S μ MMIT XT's auto-initialization function. Input is latched on the rising edge of MRST .
YF_ACK	TUI	AL	3	H9	You Failed Interrupt Acknowledge. Assertion of this input resets interrupt output YF_INT when operating in the level mode.
MSG_ACK	TUI	AL	5	K9	Message Interrupt Acknowledge. Assertion of this input resets interrupt output MSG_INT when operating in the level mode.
SSYSF	TUI	AL	113	D1	Subsystem Fail. Upon assertion, this signal propagates directly to the RT's 1553 Status Word.

13.1.9 Status Signals

Name	Type	Active	Pin Number		Description
			FP	PGA	
YF_INT	TTO ¹	AL	4	M3	You Failed Interrupt. This pin asserts upon the occurrence of interrupt events which are not masked. Either a level output or pulse output.
MSG_INT	TTO ¹	AL	6	L1	Message Interrupt. This pin asserts upon the occurrence of interrupt events which are not masked. Either a level output or pulse output.
READY	TO	AL	110	D9	READY. Assertion of this output indicates the SμMMIT XT has completed initialization or BIT, and regular operation may begin.
ECS	TO	AL	96	B11	Chip Select. Auto-initialization device select.
RDY	TTO ¹	AL	15	H10	Access Ready. Assertion of this output indicates that the host can complete the SμMMIT XT access.
TERACT	TO	AL	111	F7	TERACT. This output indicates that the terminal is actively processing a 1553 command.
BIST	TO	AL ¹	114	D10	Built-In Test. Assertion of this output indicates the SμMMIT XT is performing an internal memory test.

Note:

1. Open drain outputs; high impedance and active low.

13.1.10 Power/Ground

The following shows the package location of all power and ground pins associated with the SμMMIT XT.

Pin Number	Pin Number		Description
	FP	PGA	
V _{DD}	2, 9, 16, 34, 37, 44, 60, 69, 72, 139	A8, B3, B14, F1, F14, G7, K1, K14, N2, N13	+5 Volt Logic Power (±10%)
V _{CC}	CHA: 87, 94 CHB: 101, 107	CHA: C9, C10, E8 CHB: C1, D3, F8	XT15 & XT12: +5 Volt Transceiver Power (+10%,-5%) Recommended de-coupling capacitors: 4.7μF and .1μF XT5: +5 Volt Transceiver Power (±10%) Recommended de-coupling capacitors: 4.7μF and .1μF
V _{EE}	CHA: 86, 91 CHB: 100, 104	CHA: D7, D8 CHB: C2, D2	XT15 & XT12: -12 or -15 Volt Transceiver Power (± 5%)
V _{SS}	1, 27, 35, 36, 53, 70, 71, 123, 132, 140	A9, A13, B2, B8, D14, H1, H7, H14, M1, M14	Digital Ground
GND	CHA: 88, 89, 90, 95 CHB: 105, 106, 108, 112	CHA: B9, C7, C8, E7 CHB: B1, C3, E1, E3	Transceiver Ground

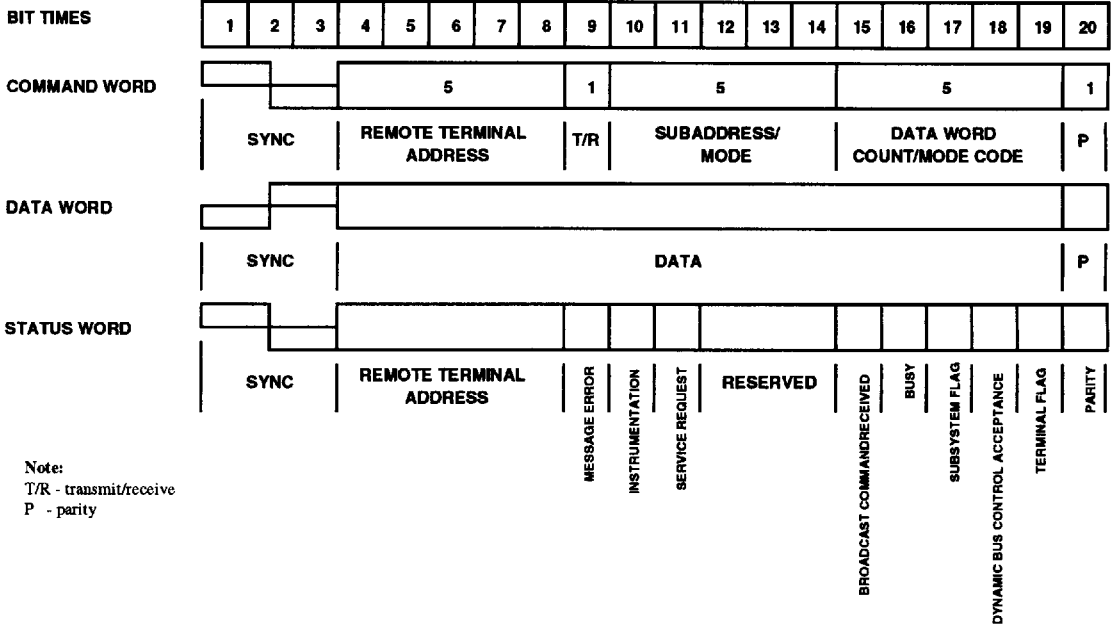

Figure 33. MIL-STD-1553B Word Formats

14.0 S μ MMIT ABSOLUTE MAXIMUM RATINGS ¹

(Referenced to V_{SS})

SYMBOL	PARAMETER	LIMIT	UNIT
V _{DD}	DC supply voltage	-0.3 to 7.0	V
V _{I/O}	Voltage on any pin	-3 to V _{DD} +3	V
T _{STG}	Storage temperature	-65 to +150	°C
T _J	Maximum junction temperature	+175	°C
I _{LU}	Latchup immunity	±150	mA
I _I	DC input current	±10	mA
T _S	Lead temperature (soldering, 5 seconds)	+300	°C
Θ _{JC}	Thermal resistance, junction-to-case	15	°C/W
P _D	Maximum power dissipation	2.5	W

Note:

1. Stresses outside the listed absolute maximum ratings may cause permanent damage to the device. This is a stress rating only, and functional operation of the device at these or any other conditions beyond limits indicated in the operational sections of this specification is not recommended. Exposure to absolute maximum rating conditions for extended periods may affect device reliability.

15.0 S μ MMIT RECOMMENDED OPERATING CONDITIONS

SYMBOL	PARAMETER	LIMIT	UNIT
V _{DD}	DC supply voltage	4.5 to 5.5	V
T _C	Temperature range	-55 to +125	°C
V _{IN}	DC input voltage	0 to V _{DD}	V
F _{IN}	Operating frequency	24 ± .01%	MHz
D _C	Duty cycle	50 ± 5	%

16.0 S μ MMIT DC ELECTRICAL CHARACTERISTICS

(V_{DD} = 5.0V \pm 10%; V_{SS} = 0V¹; -55°C < T_C < +125°C)

SYMBOL	PARAMETER	CONDITION	MIN	MAX	UNIT
V _{IL}	Low-level input voltage			.8	V
V _{IH}	High-level input voltage		2.2		V
V _{ILC}	Low-level input voltage ²			.3V _{DD}	V
V _{IHC}	High-level input voltage ²		.7V _{DD}		V
I _{IN}	Input leakage current TTL input Inputs with pull-up resistors Inputs with pull-up resistors	V _{IN} = V _{DD} or V _{SS} V _{IN} = V _{DD} V _{IN} = V _{SS}	-10 -10 -900	10 -10 -150	mA
V _{OL}	Low-level output voltage TTL outputs Single-drive buffer CMOS outputs	I _{OL} = 4.0mA I _{OL} = 1.0mA		.4 0.05	V
V _{OH}	High-level output voltage TTL outputs Single-drive buffer CMOS outputs	I _{OH} = 4.0mA I _{OH} = 1.0mA	2.4 V _{DD} -0.05		V
I _{OZ}	Three-state output leakage current TTL outputs Single-drive buffer	I _O = V _{DD} or V _{SS}	-10	+10	mA
I _{OS}	Short-circuit output current ^{3,4} TTL outputs Single-drive buffer	V _{DD} = 5.5V, V _O = 0V V _{DD} = 5.5V, V _O = V _{DD}	-100	+100	mA
C _{IN}	Input capacitance ⁵	f = 1MHz @ 0V		15	pF
C _{OUT}	Output capacitance ⁵ Single-drive buffer	f = 1MHz @ 0V		15	pF
C _{IO}	Bidirectional capacitance ⁵	f = 1MHz @ 0V		25	pF
Q _{IDD}	Quiescent current ⁶	f = 0MHz		1	mA
S _{IDD}	Standby operating current	f = 24MHz		40	mA

Notes:

1. Maximum allowable relative shift = 50mV.
2. 24MHz input only.
3. Supplied as a design limit but not guaranteed or tested.
4. Not more than one output may be shorted at a time for maximum duration of one second.
5. Capacitance measured for initial qualification or design changes which may affect the value.
6. All inputs tied to V_{DD}.

17.0 SμMMIT LX/DX & SμMMIT XT ABSOLUTE MAXIMUM RATINGS ¹

(Referenced to V_{SS})

SYMBOL	PARAMETER	LIMIT	UNIT
V _{DD}	Logic supply voltage	-0.3 to 7.0	V
P _D	Maximum power dissipation	5	W
V _{EE}	Transceiver supply voltage LX, XT15 & XT12	-22	V
V _{CC}	Transceiver supply voltage DX, XT5	-0.3 to 7.0	V
V _{DR}	Input voltage range (receiver) LX, XT15 & XT12 DX, XT5	42 10	V _{P,L-L} V _{P,L-L}
V _{IO}	Logic voltage on any pin	-3 to V _{DD} +3	V
I _{LU}	Latchup immunity	±150	mA
I _I	Logic input current	±10	mA
I _O	Peak output current (transmitter) LX, XT15 & XT12 DX, XT5	190 1000	mA mA
T _{STG}	Storage temperature	-65 to +150	°C
T _J	Maximum junction temperature LX, XT15 & XT12 DX, XT5	+150 +135	°C
T _S	Lead temperature (soldering, 5 seconds)	+300	°C
T _C	Operating temperature case	-55 to +125	°C
θ _{JC}	Thermal resistance, junction-to-case ²	7	°C/W
V _{IC}	Receiver common mode input voltage range LX, XT15 & XT12 DX, XT5	-11 to +11 -5 to +5	V V

Note:

1. Stress outside the listed absolute maximum rating may cause permanent damage to the device. This is a stress rating only, and functional operation of the device at these or any other conditions beyond limits indicated in the operational sections of this specification is not recommended. Exposure to absolute maximum rating conditions for extended periods may affect device reliability.
2. Mounting per MIL-STD-883, Method 1012.

18.0 μ MMIT LX/DX & μ MMIT XT RECOMMENDED OPERATING CONDITIONS

SYMBOL	PARAMETER	LIMIT	UNIT
V_{CC}	Transceiver supply voltage range LX, XT15 & XT12 DX, XT5	5.5 to 4.75 4.5 to 5.5	V
V_{DD}	Logic supply voltage	4.5 to 5.5	V
V_{EE}	Transceiver supply voltage range LX, XT15 & XT12	-12 or -15 ($\pm 5\%$)	V
V_{DR}	Receiver differential voltage LX, XT15 & XT12 DX, XT5	40 8.0	$V_{P,P}$
V_{IN}	Logic DC input voltage	0 to V_{DD}	V
V_{IC}	Receiver common mode input voltage range LX, XT15 & XT12 DX, XT5	± 10 ± 5.0	V
I_O	Driver peak output current LX, XT15 & XT12 DX, XT5	180 700	mA
S_D	Serial data rate	0 to 1	MHz
D_C	Clock Duty cycle	50 ± 5	%
T_C	Case operating temperature range	-55 to + 125	$^{\circ}C$
T_C	Temperature range	-55 to +125	$^{\circ}C$
F_{IN}	Operating frequency	$24 \pm .01\%$	MHz

190 μ MMIT LX/DX & μ MMIT XT DC ELECTRICAL CHARACTERISTICS

191 μ MMIT DX & XT DC Electrical Characteristics

$$V_{DD} = 5.0V \pm 10\%$$

$$V_{CC} = 5.0V \pm 10\% \text{ (DX, XT5), } 5.0V + 10\%, -5\% \text{ (LX, XT15 \& XT12)}$$

$$V_{EE} = -12.0V \text{ or } -15.0V \pm 5\% \text{ (LX, XT15 \& XT12)}$$

$$V_{SS} = 0V^1$$

$$GND = 0V^1$$

$$-55^\circ\text{C} < T_c < +125^\circ\text{C}$$

SYMBOL	PARAMETER	CONDITION	MINIMUM	MAXIMUM	UNIT
V_{IL}	Low-level input voltage			.8	V
V_{IH}	High-level input voltage		2.2		V
V_{ILC}	Low-level input voltage ²			.3 V_{DD}	V
V_{IHC}	High-level input voltage ²		.7 V_{DD}		V
I_{IN}	Input leakage current TTL input Inputs with pull-up resistors Inputs with pull-up resistors	$V_{IN} = V_{DD}$ or V_{SS} $V_{IN} = V_{DD}$ $V_{IN} = V_{SS}$	-10 -10 -900	+10 +10 -150	μ A
V_{OL}	Low-level output voltage TTL outputs Single-drive buffer CMOS outputs	$I_{OL} = 4.0\text{mA}$ $I_{OL} = 1.0\mu\text{A}$.4 0.05	V
V_{OH}	High-level output voltage TTL outputs Single-drive buffer CMOS outputs	$I_{OH} = 4.0\text{mA}$ $I_{OH} = 1.0\mu\text{A}$	2.4 $V_{DD} - 0.05$		V
I_{OZ}	Three-state output leakage current TTL outputs Single-drive buffer	$V_O = V_{DD}$ or V_{SS}	-10	+10	μ A
I_{OS}	Short-circuit output current ^{3,4} TTL outputs Single-drive buffer	$V_{DD} = 5.5V, V_O = 0V$ $V_{DD} = 5.5V, V_O = V_{DD}$	-100	+100	mA
C_{IN}	Input capacitance ⁵	$f = 1\text{MHz @ } 0V$		45	pF
C_{OUT}	Output capacitance ⁵ Single-drive buffer	$f = 1\text{MHz @ } 0V$		45	pF
C_{IO}	Bidirectional capacitance ^{5,6}	$f = 1\text{MHz @ } 0V$		45	pF

Notes:

1. Maximum allowable relative shift = 50mV.
2. CMOS input only.
3. Supplied as a design limit but not guaranteed or tested.
4. Not more than one output may be shorted at a time for maximum duration of one second.
5. Capacitance measured for initial qualification or design changes which may affect the value.
6. For all pins except CHA, CHA, CHB, and CHB.

19.2 S μ MMIT LX & XT (15 & 12) DC Electrical Characteristics ^{1,2}

$$V_{DD} = 5.0V \pm 10\%$$

$$V_{CC} = 5.0V \pm 10\%, -5\%$$

$$V_{EE} = -12.0V \text{ or } -15.0V \pm 5\%$$

$$V_{SS} = 0V^1$$

$$GND = 0V^1$$

$$-55^\circ C < T_c < +125^\circ C$$

SYMBOL	PARAMETER	CONDITION	MINIMUM	MAXIMUM	UNIT
I_{CC}	V_{CC} supply current	$V_{EE} = -12V$ $V_{CC} = 5V$ 0% duty cycle (non-transmitting)		140	mA
		50% duty cycle ($f = 1MHz$) 100% duty cycle ($f = 1MHz$)		140 140	mA mA
		$V_{EE} = -15V$ $V_{CC} = 5V$ $V_{CCA} = +5V$ to $+15V$ 0% duty cycle (non-transmitting)		140	mA
		50% duty cycle ($f = 1MHz$) 100% duty cycle ($f = 1MHz$)		140 140	mA mA
I_{EE}	I_{EE} supply current	$V_{EE} = -12V$ $V_{CC} = 5V$ 0% duty cycle (non-transmitting)		80	mA
		50% duty cycle ($f = 1MHz$) 100% duty cycle ($f = 1MHz$)		180 270	mA mA
		$V_{EE} = -15V$ $V_{CC} = 5V$ 0% duty cycle (non-transmitting)		80	mA
		50% duty cycle ($f = 1MHz$) 100% duty cycle ($f = 1MHz$)		180 270	mA mA
Q_{IDD}	Quiescent current ³	$f = 0MHz$ XT $f = 0MHz$ LX		15 1	mA mA
S_{IDD}	Standby operating current	$f = 24MHz$		40	mA

Notes:

1. Maximum allowable relative shift = 50mV.

2. As specified in test conditions.

3. All inputs tied to V_{DD} .

19.3 S μ MMIT DX & XT (5) DC Electrical Characteristics ^{1,2}

$$V_{DD} = 5.0V \pm 10\%$$

$$V_{CC} = 5.0V \pm 10\%$$

$$V_{SS} = 0V^1$$

$$GND = 0V^1$$

$$-55^\circ C < T_c < +125^\circ C$$

SYMBOL	PARAMETER	CONDITION	MINIMUM	MAXIMUM	UNIT
I_{CC}	V_{CC} supply current	0% duty cycle (non-transmitting)		110	mA
		25% duty cycle ($f = 1MHz$) ³		355	mA
		50% duty cycle ($f = 1MHz$) ³		555	mA
		80% duty cycle ($f = 1MHz$) ³		855	mA
		100% duty cycle ($f = 1MHz$)		855	mA
Q_{IDD}	Quiescent current ²	$f = 0MHz$ XT		15	mA
		$f = 0MHz$ DX		1	mA
S_{IDD}	Standby operating current	$f = 24MHz$		40	mA

Notes:

1. Maximum allowable relative shift = 50mV.

2. All inputs tied to V_{DD} .

3. Guaranteed by characterization, not tested.

20.0 S μ MMIT & S μ MMIT LX/DX AC ELECTRICAL CHARACTERISTICS

($f = 24\text{MHz} \pm .01\%$, Duty Cycle $50\% \pm 5\%$)

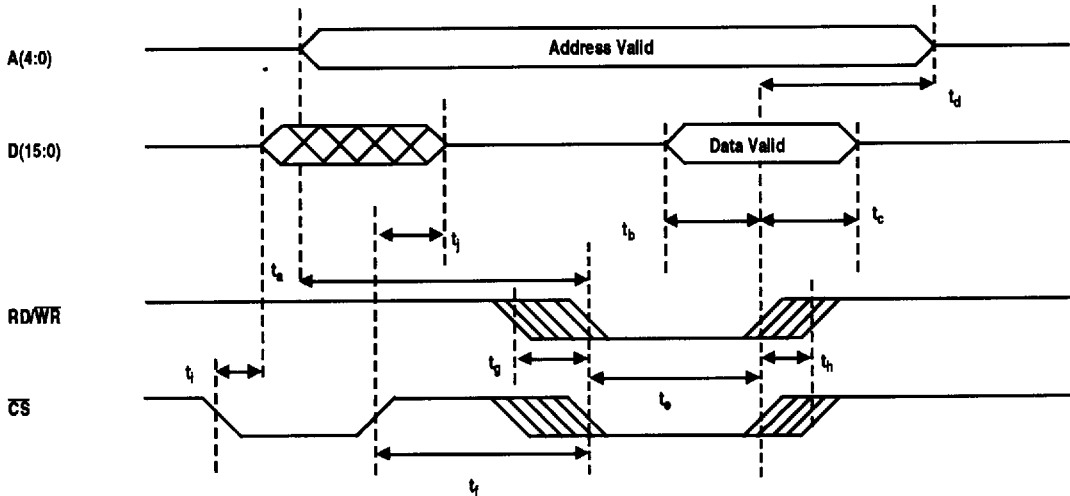

SYMBOL	PARAMETER	MINIMUM	MAXIMUM	UNITS
t_a	Address setup time	0	--	ns
t_b	Data setup time	10	--	ns
t_c	Data hold time	8	--	ns
t_d	Address hold time	8	--	ns
t_e	$\overline{CS}\downarrow$ to $\overline{CS}\uparrow$	105	--	ns
t_f	Access delay ^{1,2}	85	--	ns
t_g	RD/WR assertion to \overline{CS} assertion ³	0	--	ns
t_h	\overline{CS} negation to RD/WR negation ³	0	--	ns
t_i	\overline{CS} assertion to output enable	0	40	ns
t_j	\overline{CS} negation to output three-state ³	5	35	ns

Notes:

- Read cycle followed by a Read cycle -minimum 45ns.
Read cycle followed by a Write cycle -minimum 45ns.
Write cycle followed by a Read cycle -minimum 85ns.
Write cycle followed by a Write cycle -minimum 85ns.
- Minimum pulse width from latter rising edge of RD/WR or \overline{CS} to first falling edge.
- Guaranteed by characterization (not tested).

Figure 34. Register Write Timing

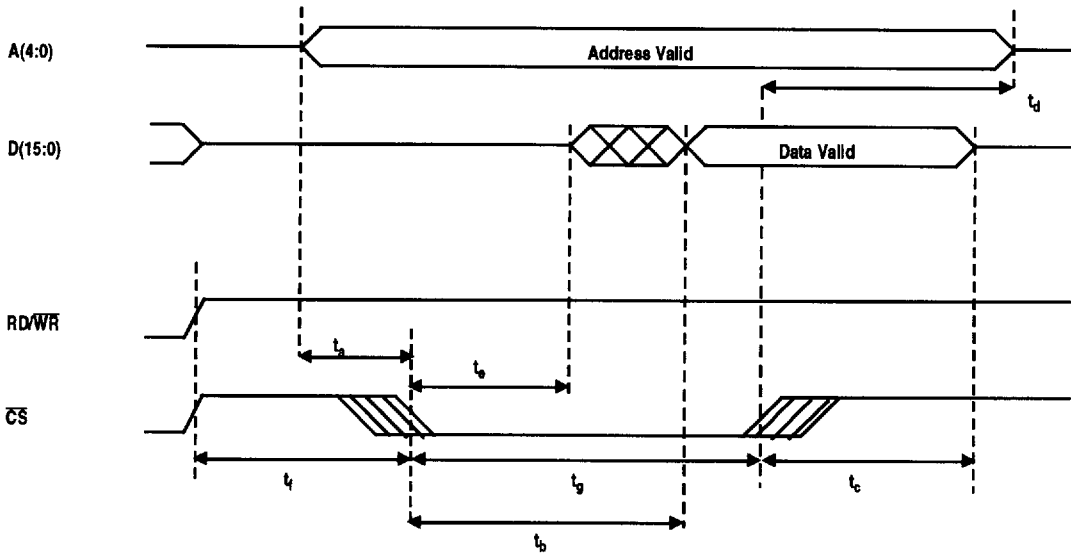

SYMBOL	PARAMETER	MINIMUM	MAXIMUM	UNITS
t_a	Address setup time	0	--	ns
t_b	\overline{CS} to assertion to output enable data valid	--	95	ns
t_c	\overline{CS} negation to output disabled ¹	5	35	ns
t_d	Address hold time	0	--	ns
t_e	\overline{CS} assertion to output enable data invalid	0	40	ns
t_f	Access delay ^{2,3}	45	--	ns
t_g	$\overline{CS}\downarrow$ to $\overline{CS}\uparrow$	105	--	ns

Notes:

1. Guaranteed by characterization (not tested).
2. Minimum pulse width from latter rising edge of RD/WR or \overline{CS} to first falling edge.
3. Read cycle followed by a Read cycle - minimum 45ns.
 Read cycle followed by a Write cycle - minimum 45ns.
 Write cycle followed by a Read cycle - minimum 85ns.
 Write cycle followed by a Write cycle - minimum 85ns.

Figure 35. Register Read Timing

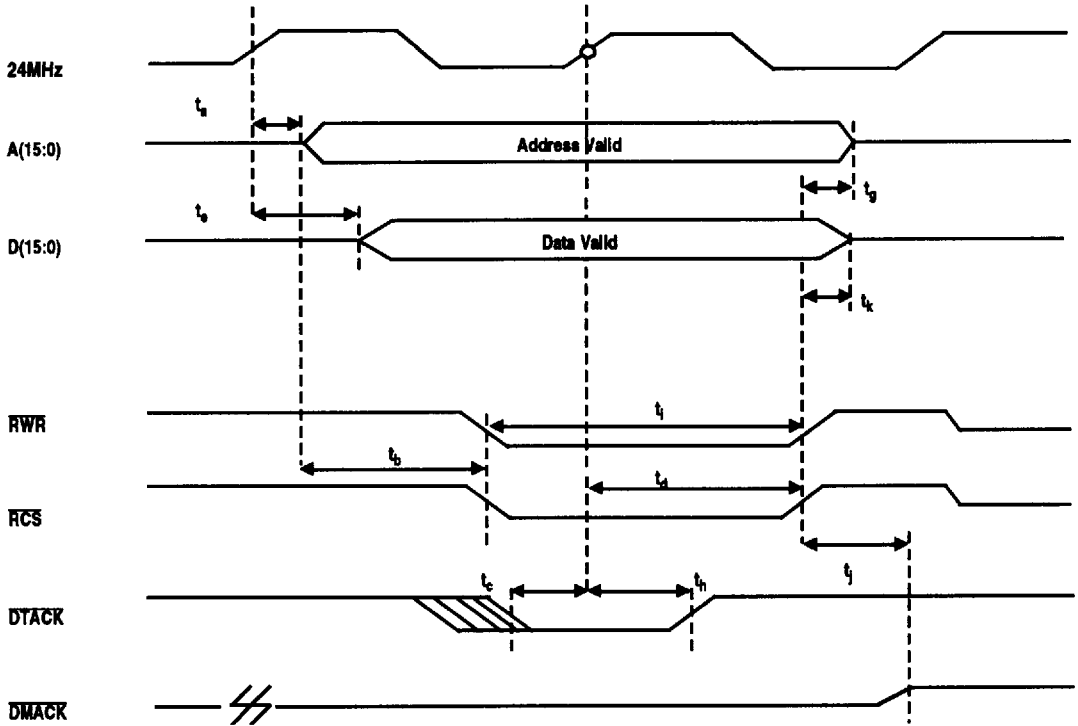

SYMBOL	PARAMETER	MINIMUM	MAXIMUM	UNITS
t_a	Address propagation delay	0	18	ns
t_b	Address valid to RCS, RWR assertion	15	35	ns
t_c	DTACK setup time	10	--	ns
t_d	RCS and RWR hold time ¹	20	50	ns
t_e	Data propagation delay	20	60	ns
t_g	Address hold time	10	30	ns
t_h	DTACK hold time	10	--	ns
t_i	RWR and RCS pulse width (DTACK tied to ground)	34	--	ns
t_j	RWR and RCS \uparrow to DMACK \uparrow ²	15	125	ns
t_k	Data hold time ²	10	40	ns

Notes:

1. Pulse width duration is measured with respect to the S μ MMIT recognizing DTACK assertion.
2. Guaranteed by characterization (not tested).

Figure 36. Memory Write Timing

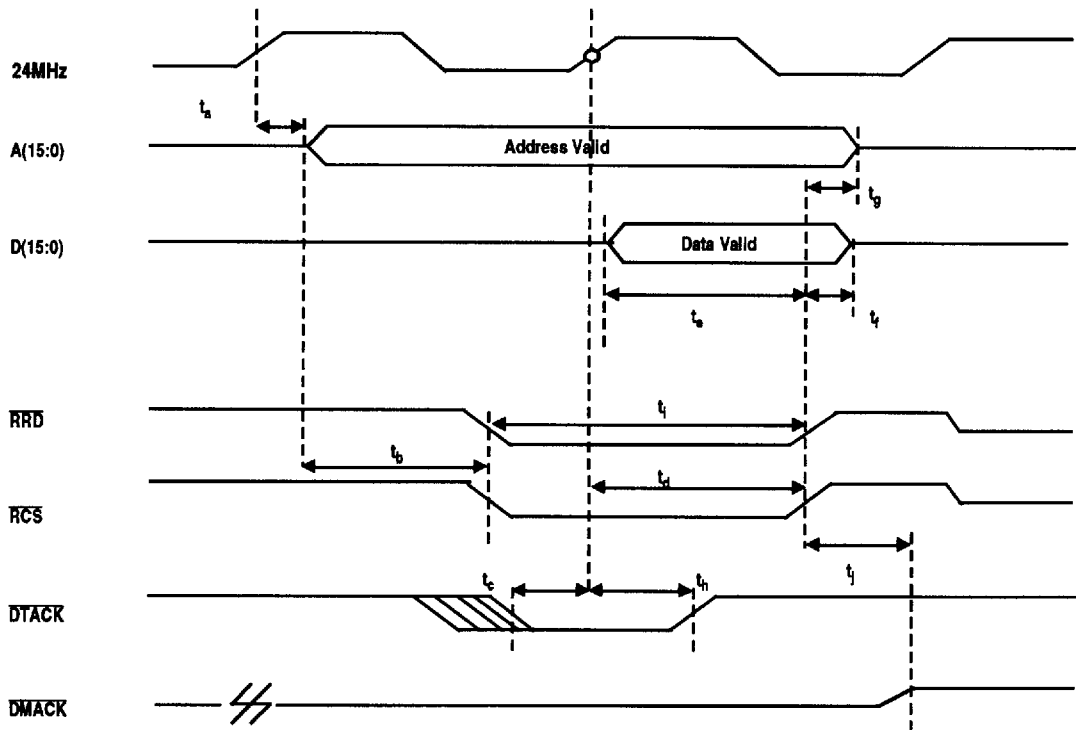

SYMBOL	PARAMETER	MINIMUM	MAXIMUM	UNITS
t_a	Address propagation delay	0	18	ns
t_b	Address valid to RCS, RRD assertion	15	35	ns
t_c	DTACK setup time	10	--	ns
t_d	RCS and RRD hold time ¹	20	50	ns
t_e	Data setup delay	12	--	ns
t_f	Data hold delay	0	--	ns
t_g	Address hold time	10	30	ns
t_h	DTACK hold time	10	--	ns
t_i	RRD and RCS pulse width (DTACK tied to ground)	34	--	ns
t_j	RRD and RCS \uparrow to DMACK \uparrow ²	15	45	ns

Notes:

1. Pulse width duration is measured with respect to the S μ MMIT recognizing DTACK assertion.
2. Guaranteed by characterization (not tested).

Figure 37. Memory Read Timing

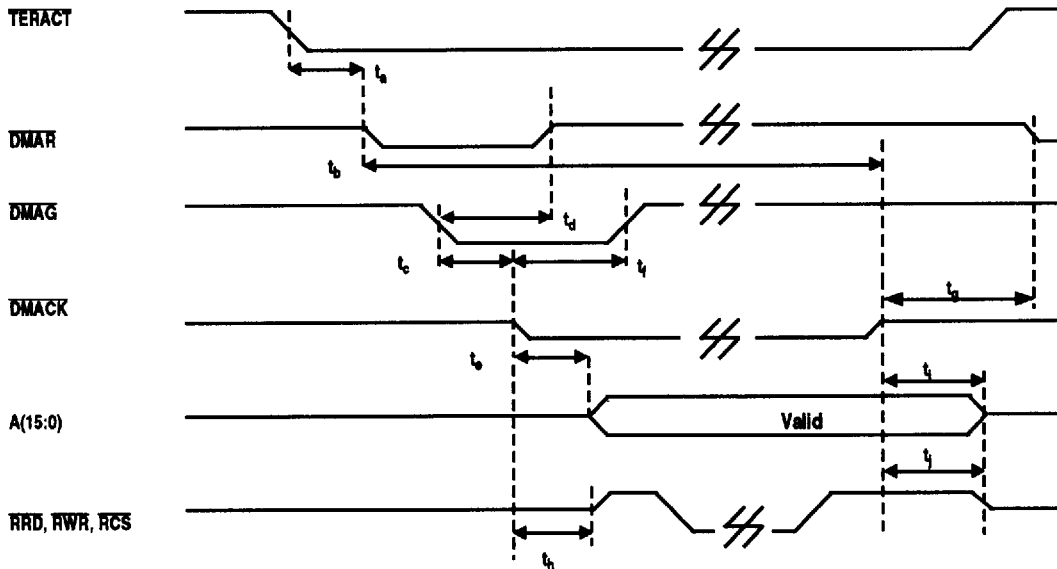

SYMBOL	PARAMETER	MINIMUM	MAXIMUM	UNITS
t_a	TERACT assertion to DMAR assertion	5	--	μ s
t_b	DMAR assertion to DMACK negation	--	16	μ s
	Bus Controller	--	7	μ s
	Remote Terminal	--	7	μ s
	Remote Terminal and Monitor	--	7	μ s
t_c	DMAG assertion to DMACK assertion	0	30	ns
t_d	DMAG assertion to DMAR negation ¹	0	35	ns
t_e	DMACK assertion to address bus active	0	5	ns
t_f	DMACK assertion to DMAG negation	10	--	ns
t_g	DMACK negation to DMAR assertion	500	--	ns
t_h	DMACK assertion to RAM control active (negated)	0	5	ns
t_i	DMACK negation to A(15:0) three-state ¹	--	5	ns
t_j	DMACK negation to RAM control disabled ¹	--	5	ns

Note:

1. Guaranteed by characterization (not tested).

Figure 38. DMA Timing

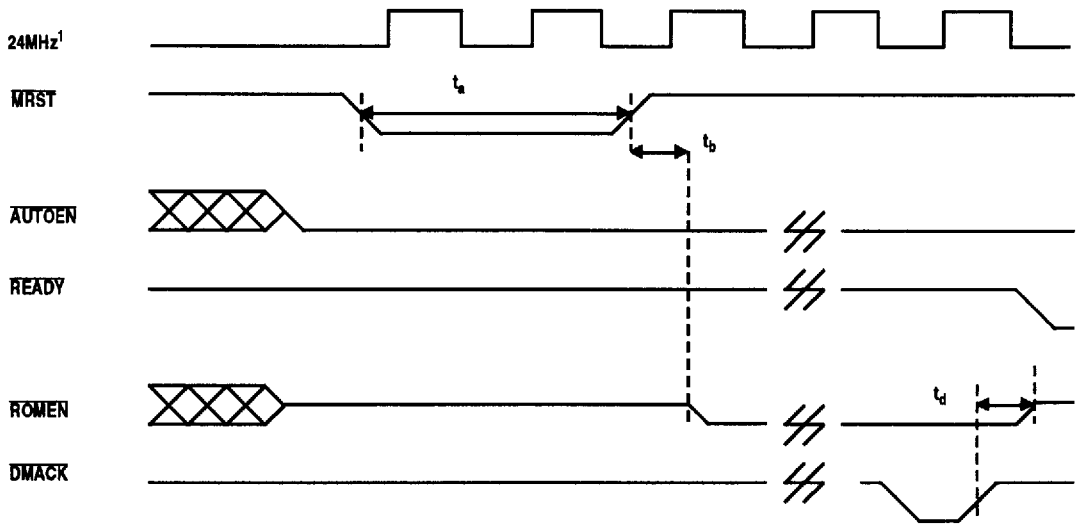

Figure 38. DMA Timing

SYMBOL	PARAMETER	MINIMUM	MAXIMUM	UNITS
t_a	MRST pulse width	500	--	ns
t_b	MRST negation to ROMEN assertion	--	5	ms
t_d	DMACK negation to ROMEN negation	--	500	ns

Note:

1. SμMMIT must receive two 24MHz clock cycles before deassertion of MRST.

Figure 39. Power-up Master Reset Timing

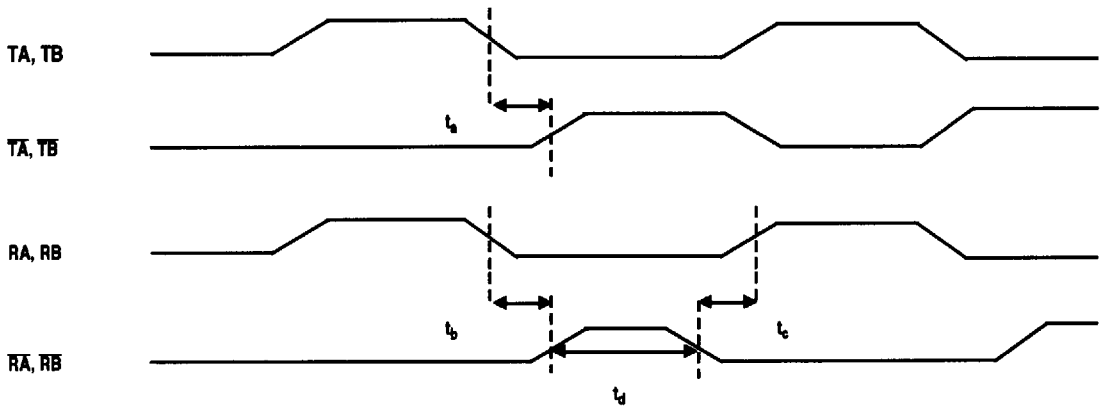

SYMBOL	PARAMETER	MINIMUM	MAXIMUM	UNITS
t_a	Biphase output skew	--	10	ns
t_b	Biphase input skew (low to high) ¹	--	250	ns
t_c	Biphase input skew (high to low) ¹	--	250	ns
t_d	Biphase input pulse width ¹	250	--	ns

Note:

1. Guaranteed by characterization (not tested).

Figure 40. Biphase Timing (SμMMIT only)

21.0 μ MMIT XT AC ELECTRICAL CHARACTERISTICS

($f = 24\text{MHz} \pm 0.01\%$, Duty Cycle $50\% \pm 5\%$)

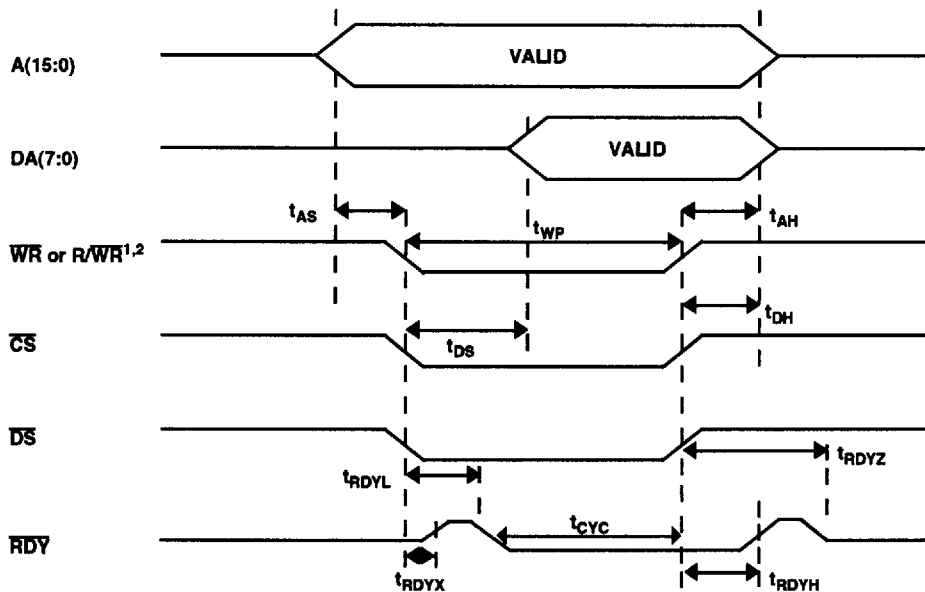

SYMBOL	PARAMETER	MINIMUM	MAXIMUM	UNITS
t_{AS}	Address setup time	5	--	ns
t_{DS}	Data setup time	--	0	ns
t_{WP}	Write pulse width (non-contented)	230 ⁴	--	ns
t_{WP}	Write pulse width (contented)	1700 ^{3,4}	--	ns
t_{AH}	Address hold time	0	--	ns
t_{DH}	Data hold time	5	--	ns
t_{RDYL}	RDY low time (non-contented)	--	245	ns
t_{RDYL}	RDY low time (contented)	--	1700 ³	ns
t_{RDYH}	RDY high time	0	25	ns
t_{RDYX}	RDY low Z	3	--	ns
t_{RDYZ}	RDY high Z	--	33	ns
t_{CYC}	Minimum cycle time	20	--	ns

Notes:

1. A cycle begins on the latter falling edge of CS, DS and WR or R/W.
2. A cycle ends on the rising edge of either CS, DS and WR or R/W.
3. Non-buffered mode of operation.
4. For applications not using RDY signal.

Figure 41. Non-Multiplexed Memory/Register Write (8-Bit)

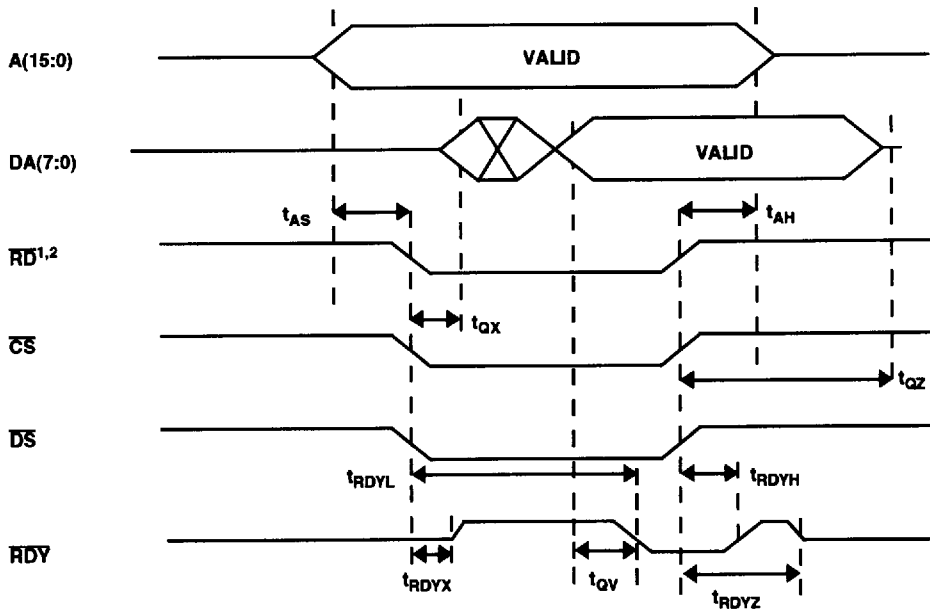

SYMBOL	PARAMETER	MINIMUM	MAXIMUM	UNITS
t_{AS}	Address setup time	5	--	ns
t_{QX}	Data low Z	0	30	ns
t_{AH}	Address hold time	0	--	ns
t_{QV}	Data valid	12	--	ns
t_{QZ}	Data high Z	0	32	ns
t_{RDYL}	RDY low time (non-contented)		245	ns
t_{RDYL}	RDY low time (contented)		1700 ³	ns
t_{RDYH}	RDY high time	0	25	ns
t_{RDYX}	RDY low Z	3	--	ns
t_{RDYZ}	RDY high Z	--	33	ns

Note:

1. A cycle begins on the latter falling edge of CS, DS and RD.
2. A cycle ends on the rising edge of either CS, DS and RD.
3. Non-buffered mode of operation.

Figure 42. Non-Multiplexed Memory/Register Read (8-Bit)

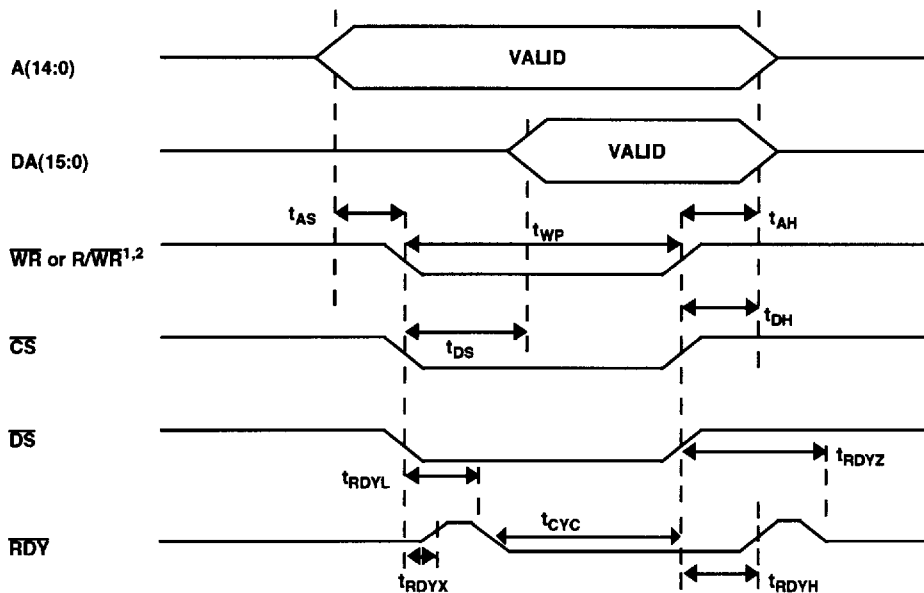

SYMBOL	PARAMETER	MINIMUM	MAXIMUM	UNITS
t_{AS}	Address setup time	5	--	ns
t_{DS}	Data setup time	--	20	ns
t_{WP}	Write pulse width (non-contented)	230 ⁴	--	ns
t_{WP}	Write pulse width (contented)	1700 ^{3,4}	--	ns
t_{AH}	Address hold time	0	--	ns
t_{DH}	Data hold time	0	--	ns
t_{RDYL}	RDY low time (non-contented)	--	245	ns
t_{RDYL}	RDY low time (contented)	--	1700 ³	ns
t_{RDYH}	RDY high time	0	25	ns
t_{RDYX}	RDY low Z	3	--	ns
t_{RDYZ}	RDY high Z	--	33	ns
t_{CYC}	Minimum cycle time	20	--	ns

Notes:

1. A cycle begins on the latter falling edge of CS, DS and WR or R/WR.
2. A cycle ends on the rising edge of either CS, DS and WR or R/WR.
3. Non-buffered mode of operation.
4. For applications not using RDY signal.

Figure 43. Non-Multiplexed Memory/Register Write (16-Bit)

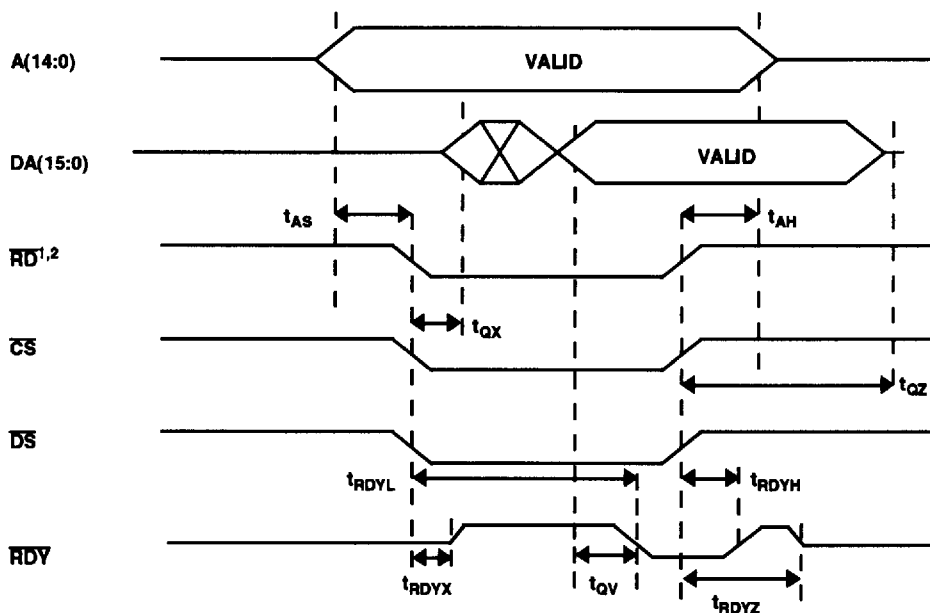

SYMBOL	PARAMETER	MINIMUM	MAXIMUM	UNITS
t_{AS}	Address setup time	5	--	ns
t_{QX}	Data low Z	0	30	ns
t_{AH}	Address hold time	0	--	ns
t_{QV}	Data valid	20	--	ns
t_{QZ}	Data high Z	0	32	ns
t_{RDYL}	RDY low time (non-contented)	--	245	ns
t_{RDYL}	RDY low time (contented)	--	1700 ³	ns
t_{RDYH}	RDY high time	0	25	ns
t_{RDYX}	RDY low Z	3	--	ns
t_{RDYZ}	RDY high Z	--	33	ns

Notes:

1. A cycle begins on the latter falling edge of CS, DS and RD.
2. A cycle ends on the rising edge of either CS, DS and RD.
3. Non-buffered mode of operation.

Figure 44. Non-Multiplexed Memory/Register Read (16-Bit)

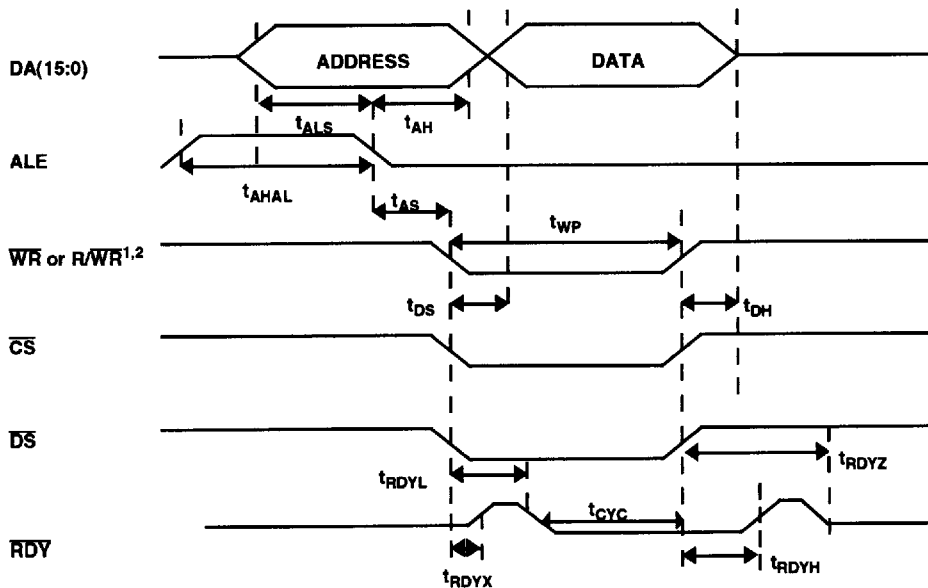

SYMBOL	PARAMETER	MINIMUM	MAXIMUM	UNITS
t_{AS}	Address setup time	0	--	ns
t_{AHAL}	ALE pulse width	20	--	ns
t_{DS}	Data setup time	--	0	ns
t_{WP}	Write pulse width (non-contented)	230 ⁴	--	ns
t_{WP}	Write pulse width (contented)	1700 ^{3,4}	--	ns
t_{AH}	Address hold time	5	--	ns
t_{DH}	Data hold time	5	--	ns
t_{RDYL}	RDY low time (non-contented)	--	245	ns
t_{RDYL}	RDY low time (contented)	--	1700 ³	ns
t_{RDYH}	RDY high time	0	25	ns
t_{RDYX}	RDY low Z	3	--	ns
t_{RDYZ}	RDY high Z	--	33	ns
t_{ALS}	Address latch setup time	22	--	ns
t_{CYC}	Minimum cycle time	20	--	ns

Notes:

1. A cycle begins on the latter falling edge of CS, DS and WR or R/WR.
2. A cycle ends on the rising edge of either CS, DS and WR or R/WR.
3. Non-buffered mode of operation.
4. For applications not using RDY signal.

Figure 45. Multiplexed Memory/Register Write (8-Bit)

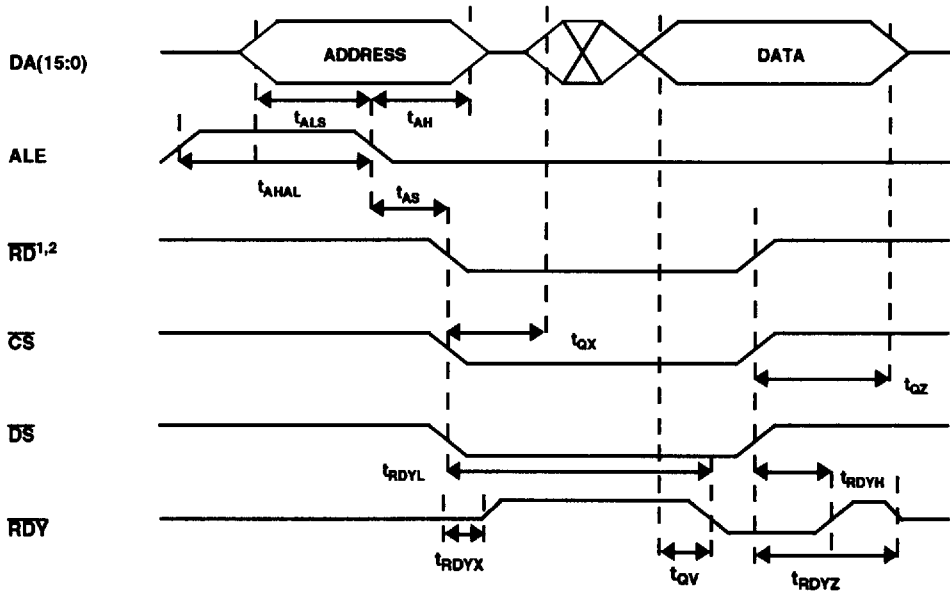

SYMBOL	PARAMETER	MINIMUM	MAXIMUM	UNITS
t_{AS}	Address setup time	0	--	ns
t_{AHAL}	ALE pulse width	20	--	ns
t_{QX}	Data low Z	0	30	ns
t_{AH}	Address hold time	5	--	ns
t_{QV}	Data valid	12	--	ns
t_{QZ}	Data high Z	3	32	ns
t_{RDYL}	RDY low time (non-contented)	--	245	ns
t_{RDYL}	RDY low time (contented)	--	1700 ³	ns
t_{RDYH}	RDY high time	0	25	ns
t_{RDYX}	RDY low Z	3	--	ns
t_{RDYZ}	RDY high Z	--	33	ns
t_{ALS}	Address latch setup time	22	--	ns

Notes:

1. A cycle begins on the latter falling edge of CS, DS and RD.
2. A cycle ends on the rising edge of either CS, DS and RD.
3. Non-buffered mode of operation.

Figure 46. Multiplexed Memory/Register Read (8-Bit)

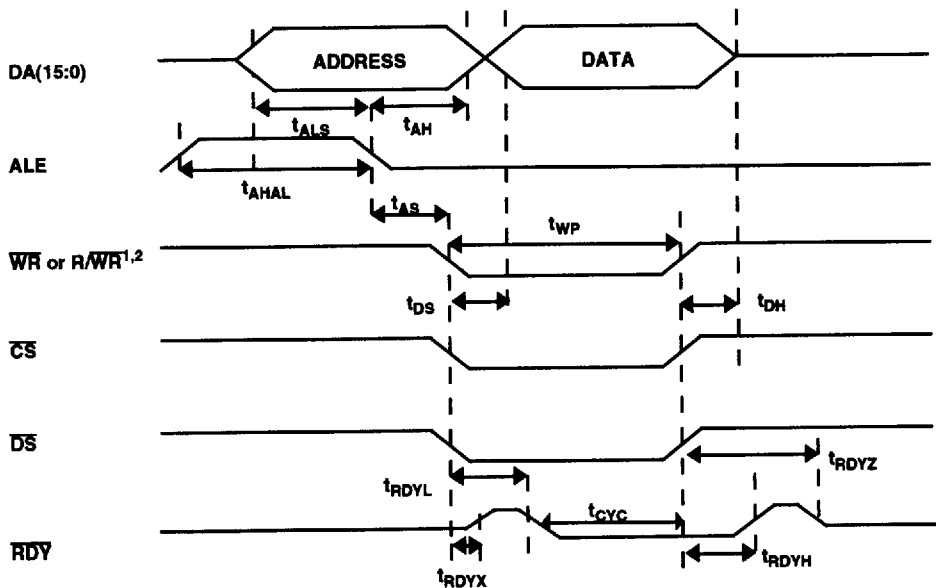

SYMBOL	PARAMETER	MINIMUM	MAXIMUM	UNITS
t_{AS}	Address setup time	0	--	ns
t_{AHAL}	ALE pulse width	20	--	ns
t_{DS}	Data setup time	--	20	ns
t_{WP}	Write pulse width (non-contended)	230 ⁴	--	ns
t_{WP}	Write pulse width (contended)	1700 ^{3,4}	--	ns
t_{AH}	Address hold time	5	--	ns
t_{DH}	Data hold time	5	--	ns
t_{RDYL}	RDY low time (non-contended)	--	245	ns
t_{RDYL}	RDY low time (contended)	--	1700 ³	ns
t_{RDYH}	RDY high time	0	25	ns
t_{RDYX}	RDY low Z	3	--	ns
t_{RDYZ}	RDY high Z	--	33	ns
t_{ALS}	Address latch setup time	22	--	ns
t_{CYC}	Minimum cycle time	20	--	ns

Notes:

1. A cycle begins on the latter falling edge of \overline{CS} , \overline{DS} and \overline{WR} or $\overline{R/WR}$.
2. A cycle ends on the rising edge of either \overline{CS} , \overline{DS} and \overline{WR} or $\overline{R/WR}$.
3. Non-buffered mode of operation.
4. For applications not using RDY signal.

Figure 47. Multiplexed Memory/Register Write (16-Bit)

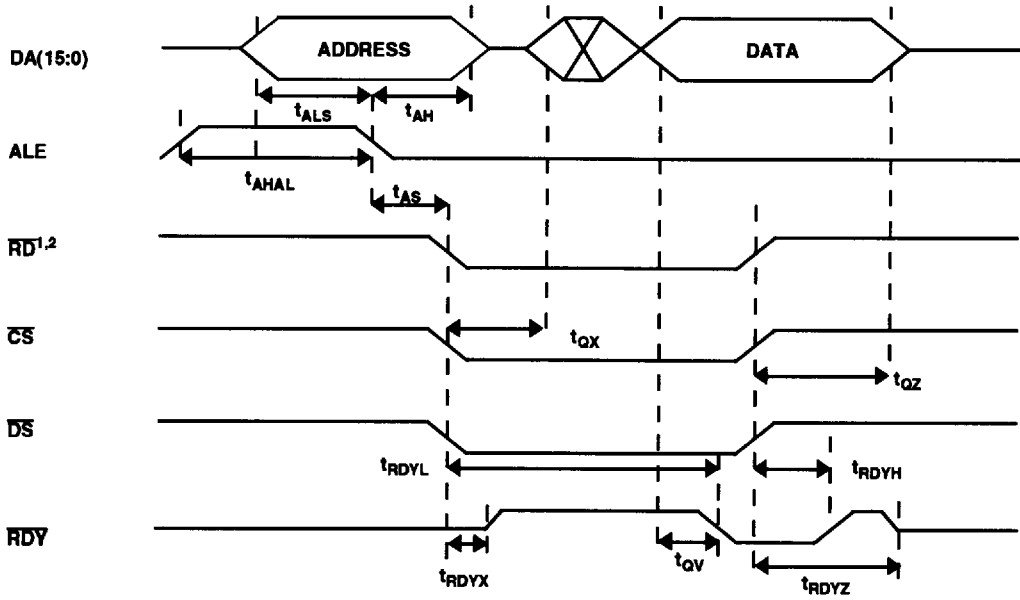

SYMBOL	PARAMETER	MINIMUM	MAXIMUM	UNITS
t_{AS}	Address setup time	0	--	ns
t_{AHAL}	ALE pulse width	20	--	ns
t_{OX}	Data low Z	0	30	ns
t_{AH}	Address hold time	5	--	ns
t_{QV}	Data valid	20	--	ns
t_{QZ}	Data high Z	3	32	ns
t_{RDYL}	RDY low time (non-contented)	--	245	ns
t_{RDYL}	RDY low time (contented)	--	1700 ³	ns
t_{RDYH}	RDY high time	0	25	ns
t_{RDYX}	RDY low Z	3	--	ns
t_{RDYZ}	RDY high Z	--	33	ns
t_{ALS}	Address latch setup time	22	--	ns

- Notes:
1. A cycle begins on the latter falling edge of CS, DS and RD.
 2. A cycle ends on the rising edge of either CS, DS and RD.
 3. Non-buffered mode of operation.

Figure 48. Multiplexed Memory/Register Read (16-Bit)

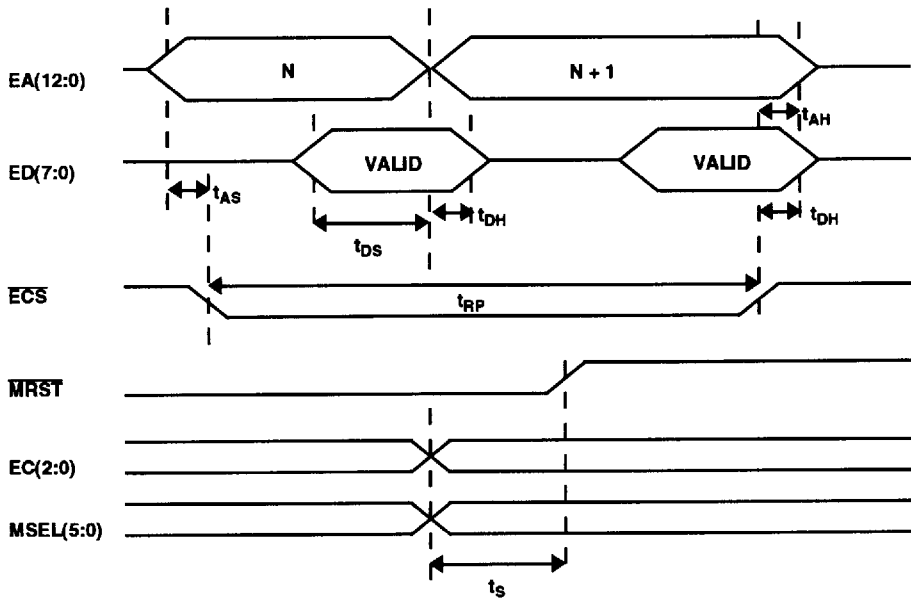

SYMBOL	PARAMETER	MINIMUM	MAXIMUM	UNITS
t_{AS}	Address setup time	35	--	ns
t_{AH}	Address hold time	35	--	ns
t_{DS}	Data setup time	41	--	ns
t_{DH}	Data hold time	5	--	ns
t_{RP}	Read pulse width	160	--	ns
t_s	Setup time	45	--	ns

Figure 49. Auto-Initialization Read Cycle

Address Bus
A(15:0), A(14:0), DA(15:0),
or DA(14:0)

Control Signals
(DS, CS, RD, R/W)

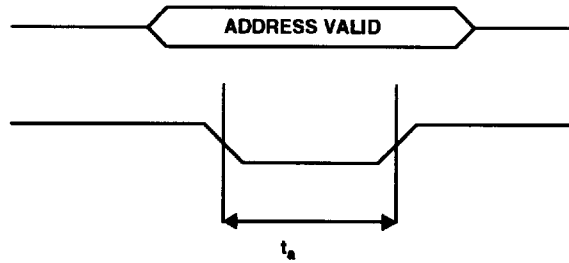

SYMBOL	PARAMETER	MINIMUM	MAXIMUM	UNITS
t_a	Maximum Register/Memory Time			
	Bus Controller	--	16	μ s
	Remote Terminal	--	7	μ s
	Remote Terminal and Monitor	--	7	μ s
	Monitor	--	7	μ s

Figure 50. Maximum Cycle Time

22.0 SμMMIT LX/DX & SμMMIT XT RECEIVER ELECTRICAL CHARACTERISTICS

22.1 SμMMIT LX & XT (15 & 12) Receiver Electrical Characteristics

VDD = 5.0V±10%

VSS = 0V

VCC = 5.0V +10%, -5%

GND = 0V

VEE = -12.0V or -15.0V±5%

-55°C < Tc < +125°C

SYMBOL	PARAMETER	CONDITION	MINIMUM	MAXIMUM	UNIT
R_{IZ}^1	Differential (receiver) input impedance	Input $f = 1\text{MHz}$ (no transformer in circuit)	15		Kohms
V_{IC}^1	Common mode input voltage	Direct-coupled stub; input $1.2V_{PP}$, 200ns rise/fall time ±25ns, $f = 1\text{MHz}$	-10	+10	V
V_{TH}	Input threshold voltage (no response) ¹	Transformer-coupled stub; input at $f = 1\text{MHz}$, rise/fall time 200ns at (Receiver output 0 → 1 transition)		0.20	$V_{PP,L-L}$
	Input threshold voltage (no response)	Direct-coupled stub; input at $f = 1\text{MHz}$, rise/fall time 200ns at (Receiver output 0 → 1 transition)		0.28	$V_{PP,L-L}$
	Input threshold voltage (response) ¹	Transformer-coupled stub; input at $f = 1\text{MHz}$, rise/fall time 200ns at (Receiver output 0 → 1 transition)	0.86	14.0	$V_{PP,L-L}$
	Input threshold voltage (response) ¹	Direct-coupled stub; input at $f = 1\text{MHz}$, rise/fall time 200ns at (Receiver output 0 → 1 transition)	1.20	20.0 ¹	$V_{PP,L-L}$
CMRR ¹	Common mode rejection ratio		Pass/Fail ²		N/A

Notes:

1. Guaranteed by device characterization, not tested.

2. Pass/fail criteria per the test method described in MIL-HDBK-1553 Appendix A, RT Validation Test Plan, Section 5.1.2.2, Common Mode Rejection.

22.2 μ MMIT DX & XT (5) Receiver Electrical Characteristics

V_{DD} = 5.0V±10%

GND = 0V

V_{CC} = 5.0V±10%

-55°C < T_c < +125°C

V_{SS} = 0V

SYMBOL	PARAMETER	CONDITION	MINIMUM	MAXIMUM	UNIT
V _{IC} ¹	Common mode input voltage	Direct-coupled stub; input 1.2V _{pp} , 200ns rise/fall time ±25ns, f = 1MHz	-5	5	V
V _{TH}	Input threshold voltage (no response) ¹	Transformer-coupled stub; input at f = 1MHz, rise/fall time 200ns at (Receiver output 0 → 1 transition)		0.20	V _{PP,L-L}
	Input threshold voltage (no response)	Direct-coupled stub; input at f = 1MHz, rise/fall time 200ns at (Receiver output 0 → 1 transition)		0.28	V _{PP,L-L}
	Input threshold voltage (response) ¹	Transformer-coupled stub; input at f = 1MHz, rise/fall time 200ns at (Receiver output 0 → 1 transition)	0.86	14.0	V _{PP,L-L}
	Input threshold voltage (response) ¹	Direct-coupled stub; input at f = 1MHz, rise/fall time 200ns at (Receiver output 0 → 1 transition)	1.20	20.0	V _{PP,L-L}
CMRR ^{1,2}	Common mode rejection ratio		Pass/Fail		N/A
V _{IDR}	Differential input voltage level		--	8.0	V _{P-P}

Notes:

1. Guaranteed by device characterization, not tested.

2. Pass/fail criteria per the test method described in MIL-HDBK-1553 Appendix A, RT Validation Test Plan, Section 5.1.2.2, Common Mode Rejection.

23.0 μ MMIT LX/DX & μ MMIT XT TRANSMITTER ELECTRICAL CHARACTERISTICS

23.1 μ MMIT LX & XT (15 & 12) Transmitter Electrical Characteristics

$$V_{DD} = 5.0V \pm 10\%$$

$$V_{SS} = 0V$$

$$V_{CC} = 5.0V +10\%, -5\%$$

$$GND = 0V$$

$$V_{EE} = -12.0V \text{ or } -15.0V \pm 5\%$$

$$-55^\circ C < T_C < +125^\circ C$$

SYMBOL	PARAMETER	MINIMUM	MAXIMUM	UNIT	CONDITION
V_O	Output voltage swing per MIL-STD-1553B ¹ (see figure 52)	18	27	$V_{PP,L-L}$	Transformer-coupled stub, figure 51, Point A; input $f = 1\text{MHz}$, $R_L = 70$ ohms
	per MIL-STD-1553B (see figure 52)	6.0	9	$V_{PP,L-L}$	Direct-coupled stub, figure 51, Point A; input $f = 1\text{MHz}$, $R_L = 35$ ohms
	per MIL-STD-1553A ¹ (see figure 52)	6.0	20	$V_{PP,L-L}$	Figure 51, Point A; input $f = 1\text{MHz}$, $R_L = 35$ ohms
$V_{NS} 1$	Output noise voltage differential (see figure 52)		14	mV-RMS_L	Transformer-coupled stub, figure 51, Point A; input $f = \text{DC to } 10\text{MHz}$, $R_L = 70$ ohms
			5	mV-RMS_L	Direct-coupled stub, figure 51, Point A; input $f = \text{DC to } 10\text{MHz}$, $R_L = 35$ ohms
$V_{OS} 1$	Output symmetry (see figure 52)	-250	+250	$\text{mV}_{PP,L-L}$	Transformer-coupled stub, figure 51, Point A; $R_L = 70$ ohms, measurement taken $2.5\mu\text{s}$ after end of transmission
			-90	+90	$\text{mV}_{PP,L-L}$
$V_{DIS} 1$	Output voltage distortion (overshoot or ring) (see figure 52)	-900	+900	$\text{mV}_{\text{peak},L-L}$	Transformer-coupled stub, figure 51, Point A; $R_L = 70$ ohms
			-300	+300	$\text{mV}_{\text{peak},L-L}$
$T_{IZ} 1$	Terminal input impedance	1		Kohm	Transformer-coupled stub, figure 51, Point A; input $f = 75\text{KHz to } 1\text{MHz}$ (power on or power off; non-transmitting, R_L removed from circuit).
			2		Kohm

Note:

1. Guaranteed by device characterization, not tested.

23.2 μ MMIT DX & XT (5) Transmitter Electrical Characteristics

$V_{DD} = 5.0V \pm 10\%$

$GND = 0V$

$V_{CC} = 5.0V \pm 10\%$

$-55^{\circ}C < T_C < +125^{\circ}C$

$V_{SS} = 0V$

SYMBOL	PARAMETER	MINIMUM	MAXIMUM	UNIT	CONDITION
V_O	Output voltage swing per MIL-STD-1553B ¹ (see figure 52)	18	27	$V_{PP,L-L}$	Transformer-coupled stub, figure 51, Point A; input $f = 1\text{MHz}$, $R_L = 70\text{ ohms}$
	per MIL-STD-1553B (see figure 52)	6.0	9	$V_{PP,L-L}$	Direct-coupled stub, figure 51, Point A; input $f = 1\text{MHz}$, $R_L = 35\text{ ohms}$
	per MIL-STD-1553A ¹ (see figure 52)	6.0	20	$V_{PP,L-L}$	
V_{NS}^1	Output noise voltage differential (see figure 52)		14	mV-RMS_L	Transformer-coupled stub, figure 51, Point A; input $f = \text{DC to } 10\text{MHz}$, $R_L = 70\text{ ohms}$
			10	mV-RMS_L	Direct-coupled stub, figure 51, Point A; input $f = \text{DC to } 10\text{MHz}$, $R_L = 35\text{ ohms}$
V_{OS}^1	Output symmetry (see figure 52)	-360	+360	$\text{mV}_{PP,L-L}$	Transformer-coupled stub, figure 51, Point A; $R_L = 70\text{ ohms}$, measurement taken $2.5\mu\text{s}$ after end of transmission
		-90	+90	$\text{mV}_{PP,L-L}$	Direct-coupled stub, figure 51, Point A; $R_L = 35\text{ ohms}$, measurement taken $2.5\mu\text{s}$ after end of transmission
V_{DIS}^1	Output voltage distortion (overshoot or ring) (see figure 52)	-2	+2	$V_{\text{peak},L-L}$	Transformer-coupled stub, figure 51, Point A; $R_L = 70\text{ ohms}$
		-1.0	+1.0	$V_{\text{peak},L-L}$	Direct-coupled stub, figure 51, Point A; $R_L = 35\text{ ohms}$
T_{IZ}^1	Terminal input impedance	1		Kohm	Transformer-coupled stub, figure 51, Point A; input $f = 75\text{KHz to } 1\text{MHz}$ (power on or power off; non-transmitting, R_L removed from circuit).
		2		Kohm	Direct-coupled stub, figure 51, Point A; input $f = 75\text{KHz to } 1\text{MHz}$ (power on or power off; non-transmitting, R_L removed from circuit).
T_{OZ}	Differential output impedance	10		Kohm	Input $f = 1\text{ MHz}$ (no transformer in circuit)

Note:

1. Guaranteed by device characterization, not tested.

24.0 S μ MMIT LX/DX & S μ MMIT XT AC ELECTRICAL CHARACTERISTICS

24.1 S μ MMIT LX & XT (15 & 12) AC Electrical Characteristics

$$V_{DD} = 5.0V \pm 10\%$$

$$V_{CC} = 5.0V + 10\%, -5\%$$

$$V_{EE} = -12.0V \text{ or } -15.0V \pm 5\%$$

$$V_{SS} = 0V$$

$$GND = 0V$$

$$-55^{\circ}C < T_C < +125^{\circ}C$$

SYMBOL	PARAMETER	MINIMUM	MAXIMUM	UNIT	CONDITION
t_R, t_F	Transmitter output rise/fall time (see figure 53)	100	300	ns	Input $f = 1\text{MHz}$ 50% duty cycle; direct-coupled $R_L = 35$ ohms output at 10% through 90% points TXOUT, TXOUT. Figure 53.
t_{RZCD}	Zero crossing distortion (see figure 54)	-150	150	ns	Direct-coupled stub; input $f = 1\text{MHz}$, $3 V_{PP}$ (skew INPUT $\pm 150\text{ns}$), rise/fall time 200ns.
t_{TZCS}	Zero crossing stability (see figure 54)	-25	25	ns	Input TXIN and TXIN should create Transmitter output zero crossings at 500ns, 1000ns, 1500ns, and 2000ns. These zero crossings should not deviate more than $\pm 25\text{ns}$.

24.2 S μ MMIT DX & XT (5) AC Electrical Characteristics

$$V_{DD} = 5.0V \pm 10\%$$

$$V_{CC} = 5.0V \pm 10\%$$

$$V_{SS} = 0V$$

$$GND = 0V$$

$$-55^{\circ}C < T_C < +125^{\circ}C$$

SYMBOL	PARAMETER	MINIMUM	MAXIMUM	UNIT	CONDITION
t_R, t_F	Transmitter output rise/fall time (see figure 53)	100	300	ns	Input $f = 1\text{MHz}$ 50% duty cycle; direct-coupled $R_L = 35$ ohms output at 10% through 90% points TXOUT, TXOUT. Figure 53.
t_{RZCD}	Zero crossing distortion (see figure 54)	-150	150	ns	Direct-coupled stub; input $f = 1\text{MHz}$, $3 V_{PP}$ (skew INPUT $\pm 150\text{ns}$), rise/fall time 200ns.
t_{TZCS}	Zero crossing stability (see figure 54)	-25	25	ns	Input TXIN and TXIN should create Transmitter output zero crossings at 500ns, 1000ns, 1500ns, and 2000ns. These zero crossings should not deviate more than $\pm 25\text{ns}$.

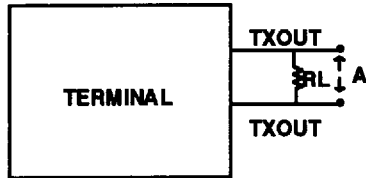

Notes:

1. Transformer Coupled Stub:
Terminal is defined as transceiver plus isolation transformer.
2. Direct Coupled Stub:
Terminal is defined as transceiver plus isolation transformer and fault resistors.

Figure 51. Transceiver Test Circuit MIL-STD-1553B

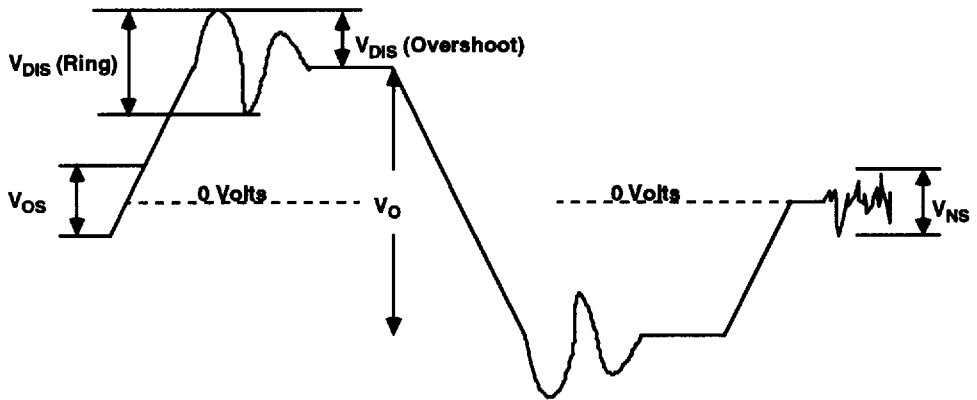

Figure 52. Transmitter Output Characteristics (V_{DIS} , V_{OS} , V_{NS} , V_O)

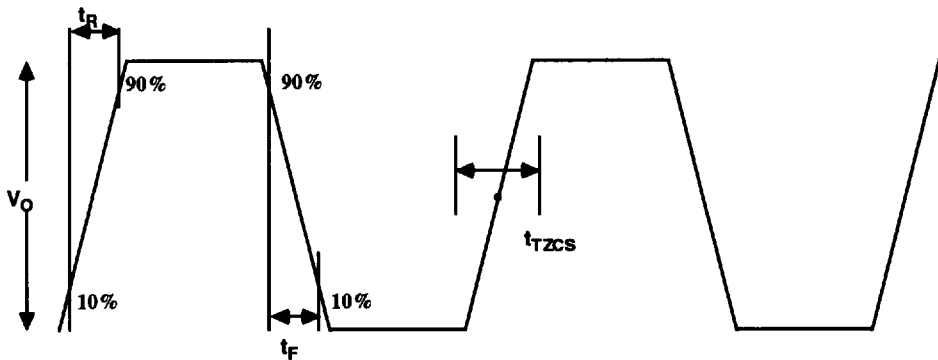

Figure 53. Transmitter Output Zero Crossing Stability, Rise Time, Fall Time (t_{TZCS} , t_R , t_F)

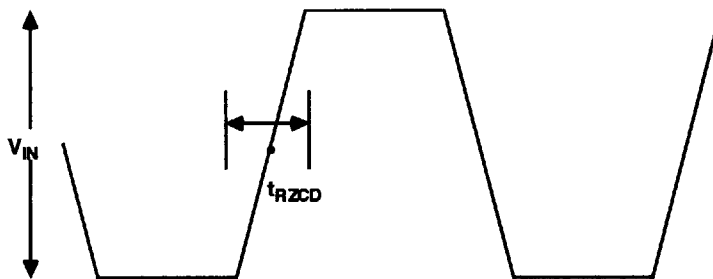

Figure 54. Receiver Input Zero Crossing Distortion (t_{RZCD})

25.0 PACKAGING

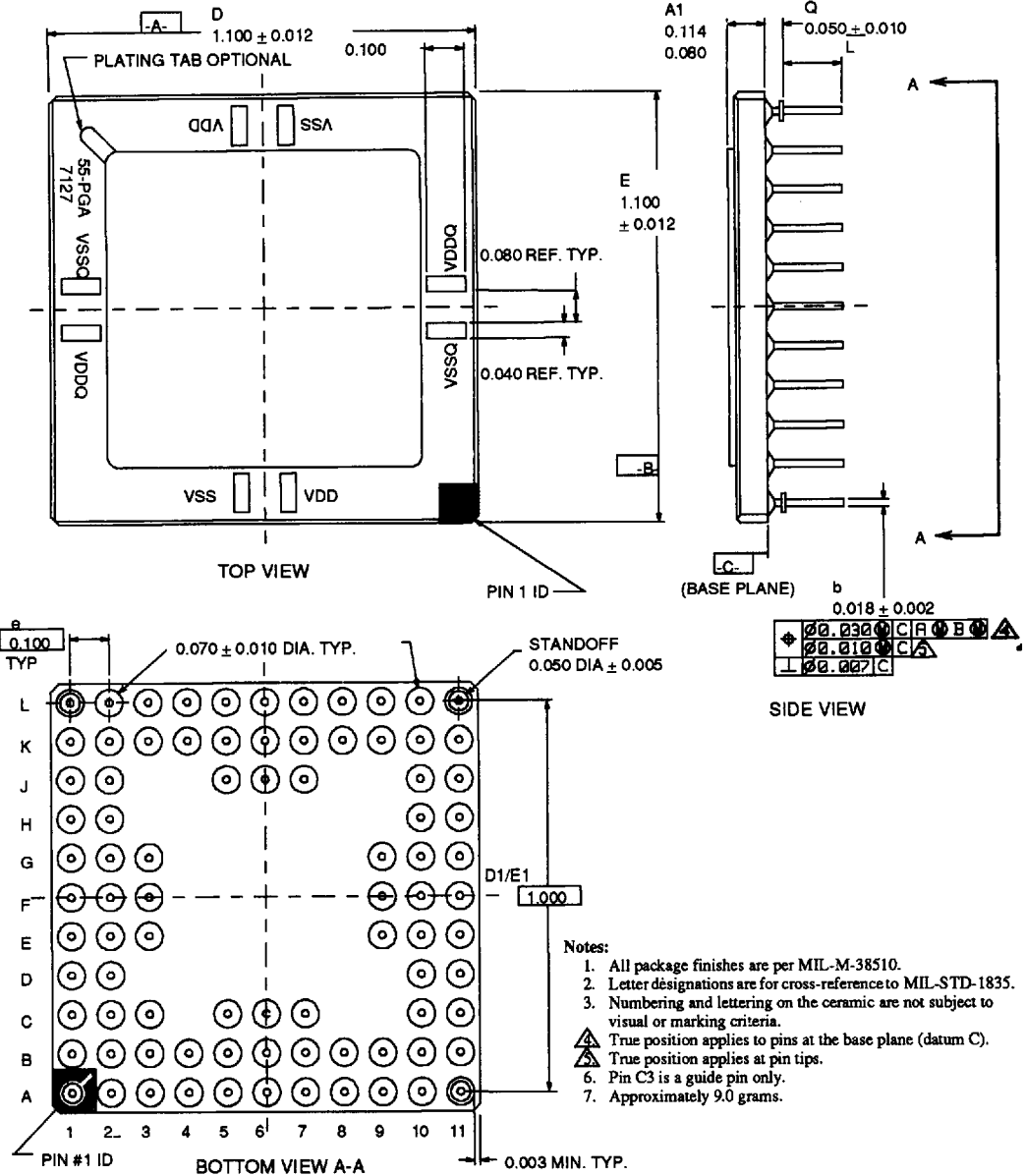
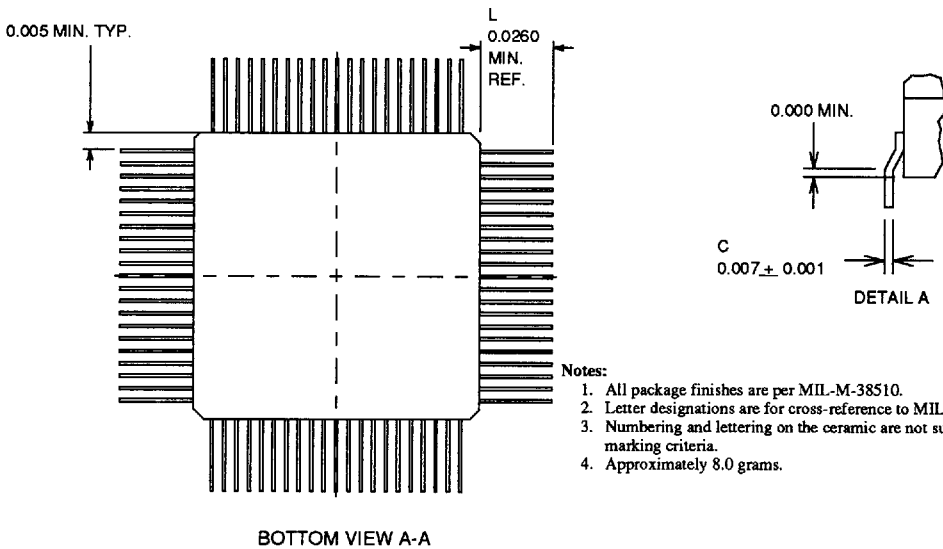
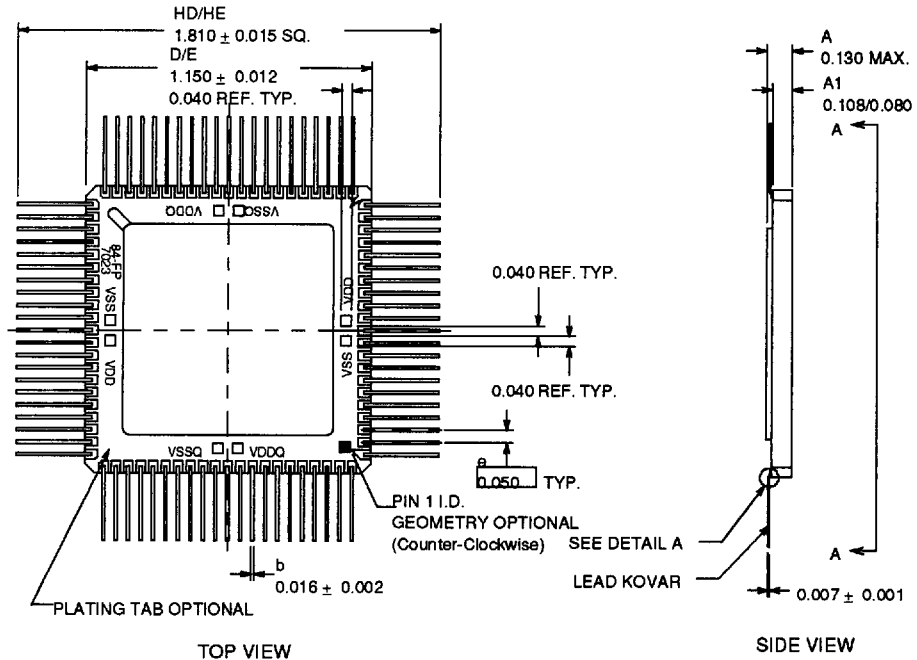

Figure 55. SμMMIT 85-Pin Pingrid Array



- Notes:
1. All package finishes are per MIL-M-38510.
 2. Letter designations are for cross-reference to MIL-STD-1835.
 3. Numbering and lettering on the ceramic are not subject to visual or marking criteria.
 4. Approximately 8.0 grams.

Figure 56. SμMMIT 84-Lead Flatpack
 (50mil lead spacing)

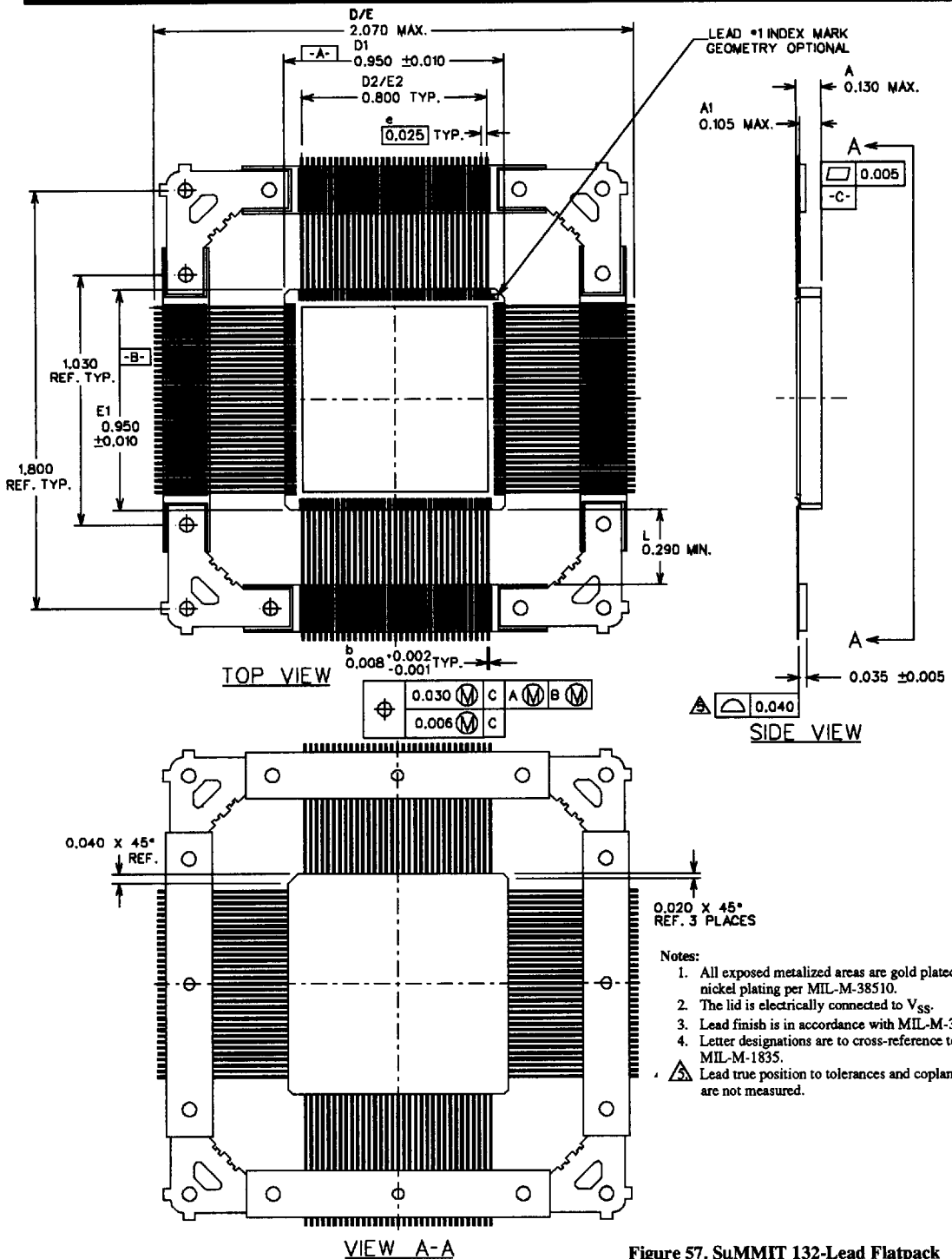
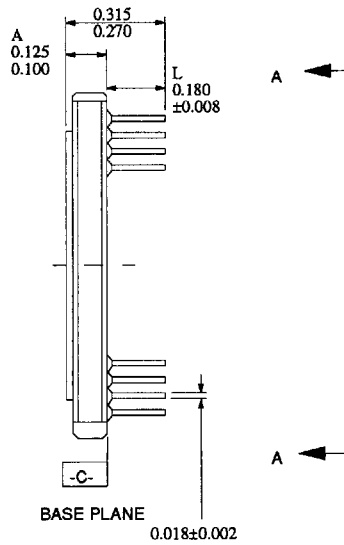
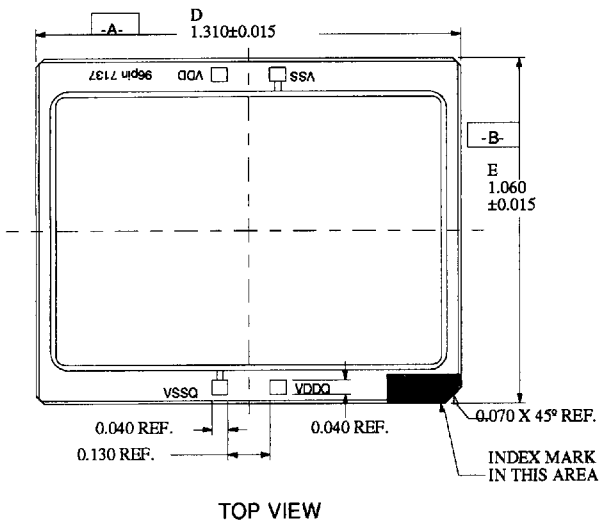
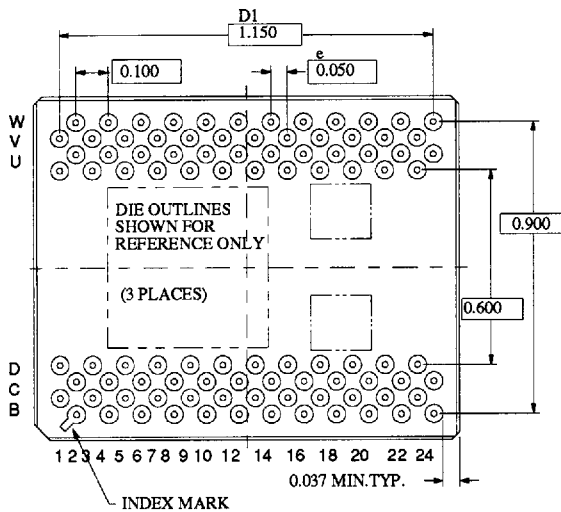

Figure 57. ΣμMMIT 132-Lead Flatpack



⊕	∅ 0.030 (M)	C	A (M)	B (M)	△
	∅ 0.010 (M)	C	△		2



- Notes:
- △ True position applies to pins at base plane (datum C).
 - △ True position applies at pin tips.
 - All package finishes are per MIL-M-38510.
 - Letter designations are for cross-reference to MIL-STD-1835.

Figure 58. μ MMIT LX/DX 96-Pin Pingrid Array

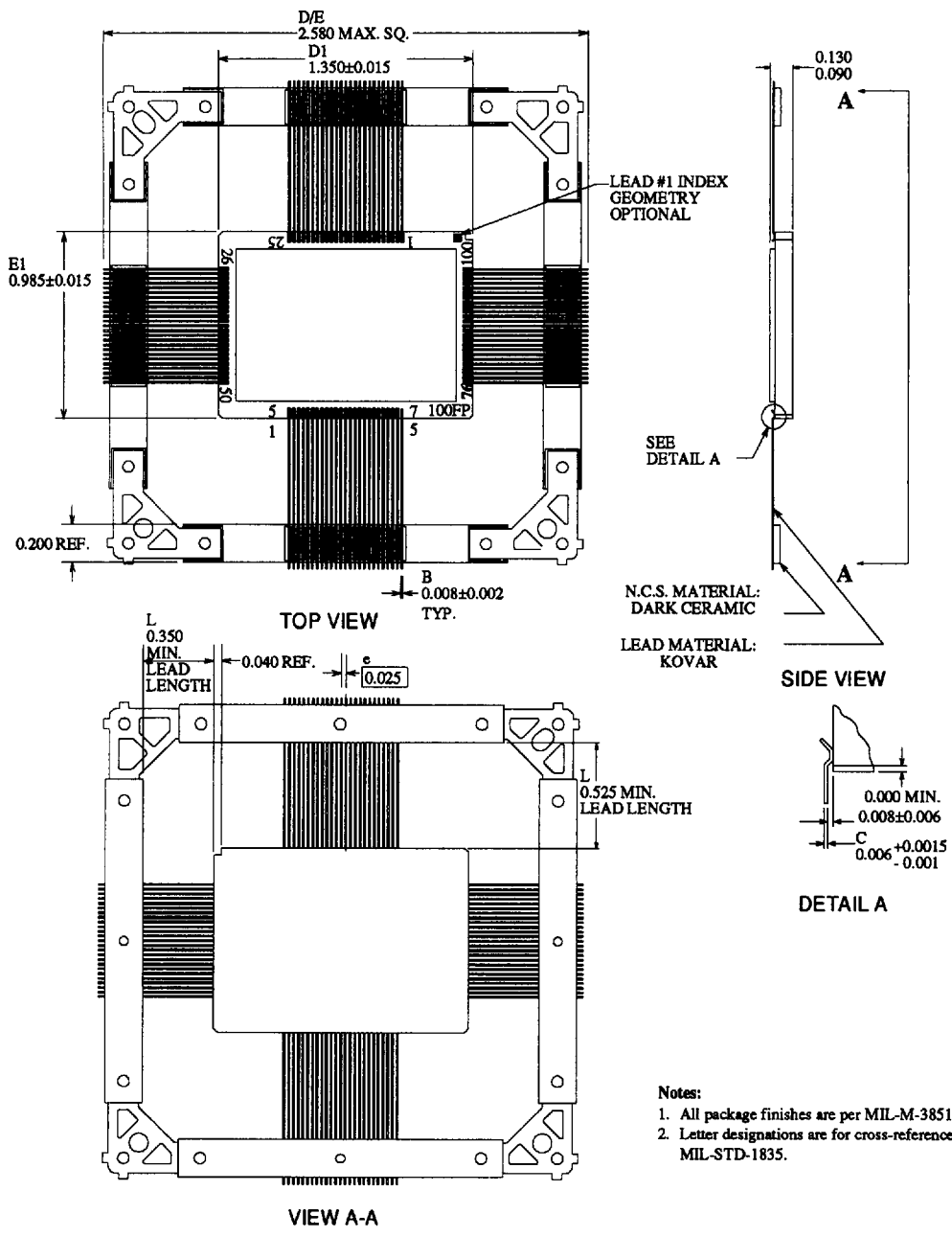
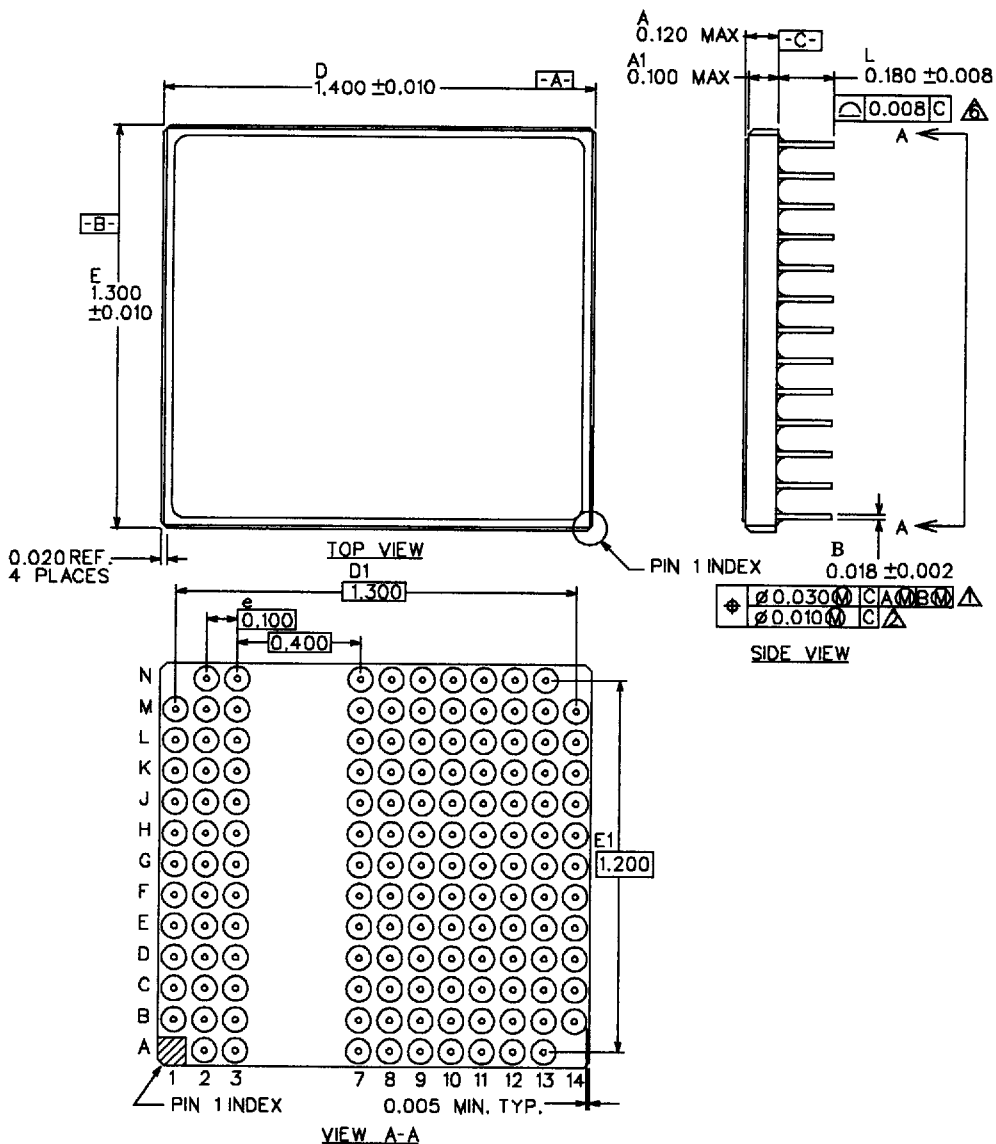
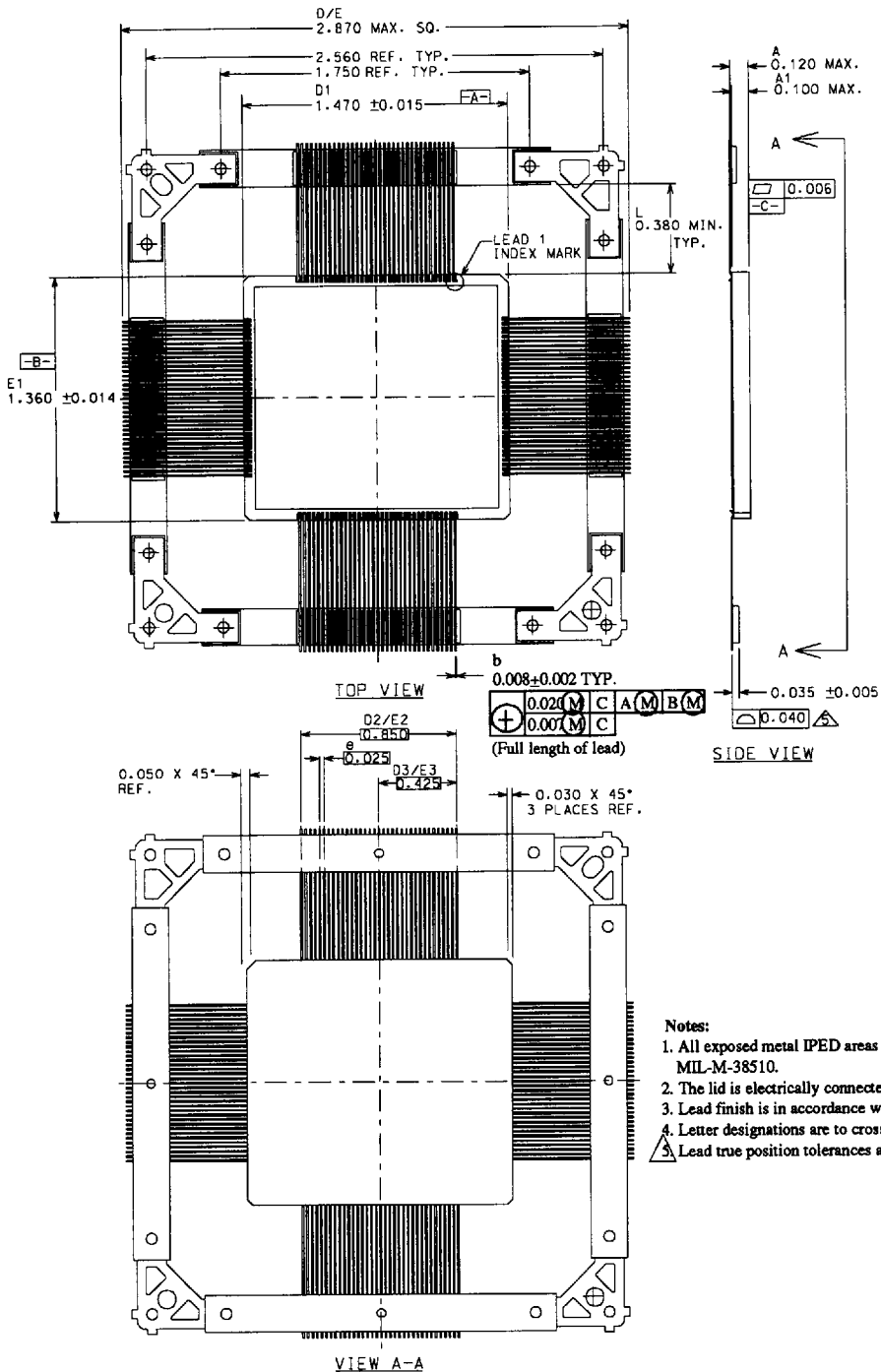

Figure 59. μ MMIT LX/DX 100-Lead Flatpack



- Notes:
- 1. True position applies to pins at the base plane (Datum C).
 - 2. True position applies at the pin tips.
 - 3. The lid is electrically connected to V_{ss}.
 - 4. Letter designations are for cross-reference to MIL-STD-1835.
 - 5. Lead finish is in accordance with MIL-M-38535.
 - 6. Coplanarity is not measured.

Figure 60. SμMMIT XT 139-Pingrid Array



- Notes:**
1. All exposed metal IPED areas are gold plated over nickel plating per MIL-M-38510.
 2. The lid is electrically connected to V_{ss}.
 3. Lead finish is in accordance with MIL-M-38535.
 4. Letter designations are to cross-reference to MIL-STD-1835.
- ⚠ Lead true position tolerances and coplanarity are not measured.

Figure 61. SμMMIT XT 140-Lead Flatpack

26.0 ORDERING INFORMATION

ENHANCED S μ MMIT MIL-STD-1553 Dual Redundant Bus Controller/Remote Terminal Monitor

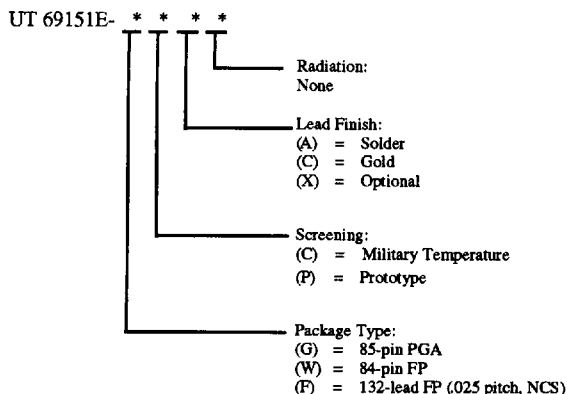

Notes:

1. Lead finish (A, C, or X) must be specified.
2. If an "X" is specified when ordering then the part marking will match the lead finish and will be either "A" (solder) or "C" (gold).
3. Military Temperature Range flow per UTMC's Manufacturing Flows documents. Devices have 48 hours of burn-in and are tested at -55°C, room temperature, and -125°C. Radiation neither tested nor guaranteed.
4. Prototypes are produced to UTMC's prototype flow, and are tested at 25°C only. Lead finish is at UTMC's option. "X" must be specified when ordering. Radiation neither tested or guaranteed.

ENHANCED S μ MMIT MIL-STD-1553 Dual Redundant Bus Controller/Remote Terminal Monitor: SMD

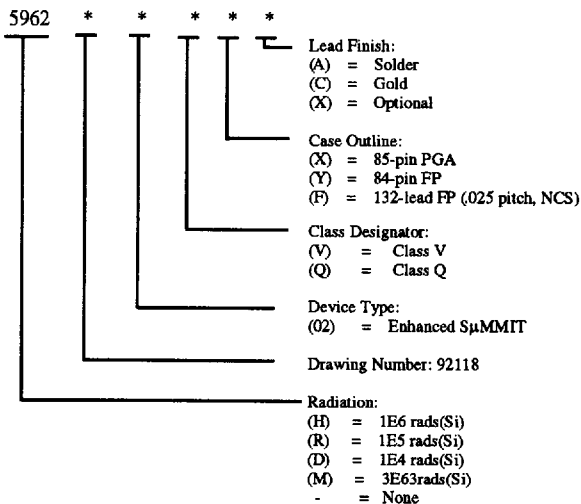

Notes:

1. Lead finish (A, C, or X) must be specified.
2. If an "X" is specified when ordering, part marking will match the lead finish and will be either "A" (solder) or "C" (gold).
3. F(3E5) and G(5E5) radiation levels also available.
4. SEU and neutron irradiation limits will be added when available.

ENHANCED S μ MMIT LXE/DXE MIL-STD-1553 Dual Redundant Bus Controller/Remote Terminal/Monitor/Transceiver Multichip Module

UT 69151E * * * * *

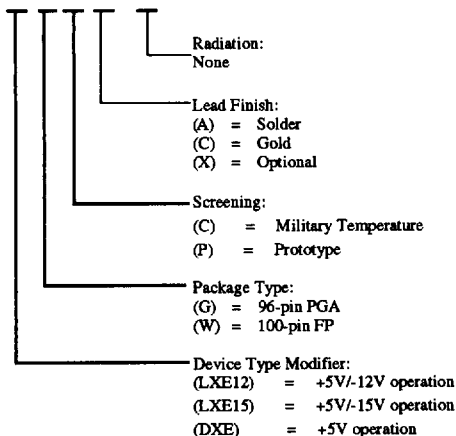

Notes:

1. Lead finish (A, C, or X) must be specified.
2. If an "X" is specified when ordering then the part marking will match the lead finish and will be either "A" (solder) or "C" (gold).
3. Military Temperature Range flow per UTMC's Manufacturing Flows documents. Devices have 48 hours of burn-in and are tested at -55°C, room temperature, and -125°C. Radiation neither tested nor guaranteed.
4. Prototypes are produced to UTMC's prototype flow, and are tested at 25°C only. Lead finish is at UTMC's option. "X" must be specified when ordering. Radiation neither tested or guaranteed.

ENHANCED S μ MMIT LXE/DXE: MIL-STD-1553 Dual Redundant Bus Controller/Remote Terminal/Monitor/Transceiver Multichip Module: SMD

5962 * * * * *

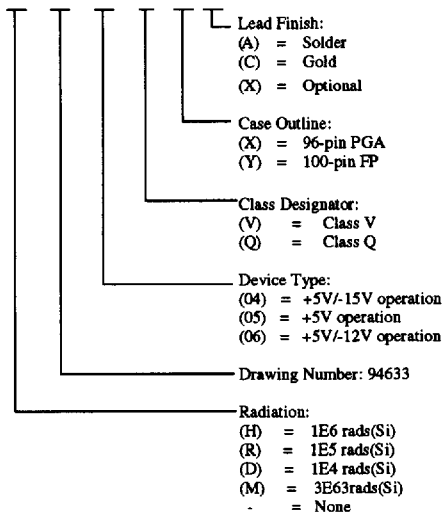

Notes:

1. Lead finish (A, C, or X) must be specified.
2. If an "X" is specified, part marking will match the lead finish and will be either "A" (solder) or "C" (gold).
3. F(3E5) and G(3E5) radiation levels also available.
4. SEU and neutron irradiation limits will be added when available.
5. LXE12 cannot be ordered rad hard.
6. LXE15 may be ordered with 1E5 total dose radiation. Co60 required. Contact factory.

ENHANCED SμMMIT XTE MIL-STD-1553 Dual Redundant Bus Controller/Remote Terminal/Monitor with Integrated Transceivers, MMU and RAM

UT 69151E * * * * *

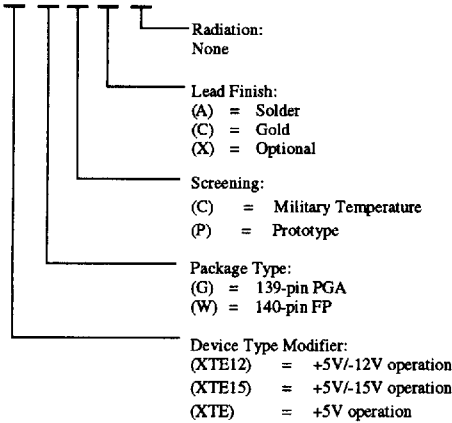

Notes:

1. Lead finish (A, C, or X) must be specified.
2. If an "X" is specified when ordering then the part marking will match the lead finish and will be either "A" (solder) or "C" (gold).
3. Military Temperature Range flow per UTMC's Manufacturing Flows documents. Devices have 48 hours of burn-in and are tested at -55°C, room temperature, and -125°C. Radiation neither tested nor guaranteed.
4. Prototypes are produced to UTMC's prototype flow, and are tested at 25°C only. Lead finish is at UTMC's option. "X" must be specified when ordering. Radiation neither tested or guaranteed.

ENHANCED SμMMIT XTE: MIL-STD-1553 Dual Redundant Bus Controller/Remote Terminal/Monitor/Transceiver Multichip Module: SMD

5962 * * * * *

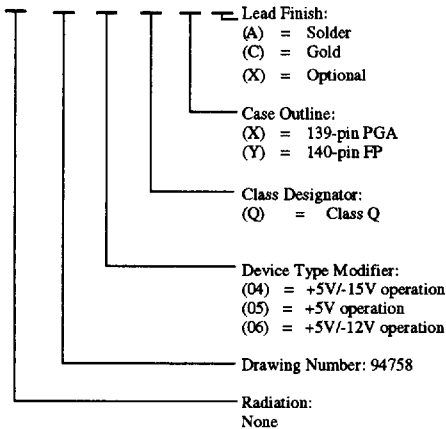

Notes:

1. Lead finish (A, C, or X) must be specified.
2. If an "X" is specified, part marking will match the lead finish and will be either "A" (solder) or "C" (gold).