

CURRENT MODE PWM CONTROL CIRCUITS

DESCRIPTION

The UTC3842 provides the necessary features to implement off-line or DC to DC fixed frequency current mode control schemes with a minimal external parts count. Internally implemented circuits include under-voltage lockout featuring start up current less than 1mA, a precision reference trimmed for accuracy at the error amp input, logic to insure latched operation, a PWM comparator which also provides current limit control, and a totem pole output stage designed to source or sink high peak current. The output stage, suitable for driving N channel MOSFETs, is low in the off state.

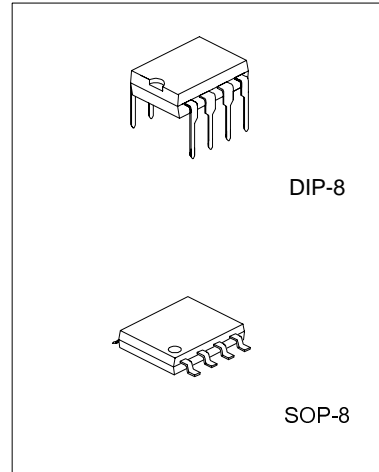

FEATURES

- *Optimized for off-line and DC to DC converts
- *Low start up current(<1mA)
- *Automatic feed forward compensation
- *Pulse-by-Pulse current limiting
- *Enhanced load response characteristics
- *Under-voltage lockout with hysteresis

- *Double pulse Suppression
- *High current totem pole output
- *Internally trimmed band-gap reference
- *500kHz operation
- *Low Ro error amp

BLOCK DIAGRAM

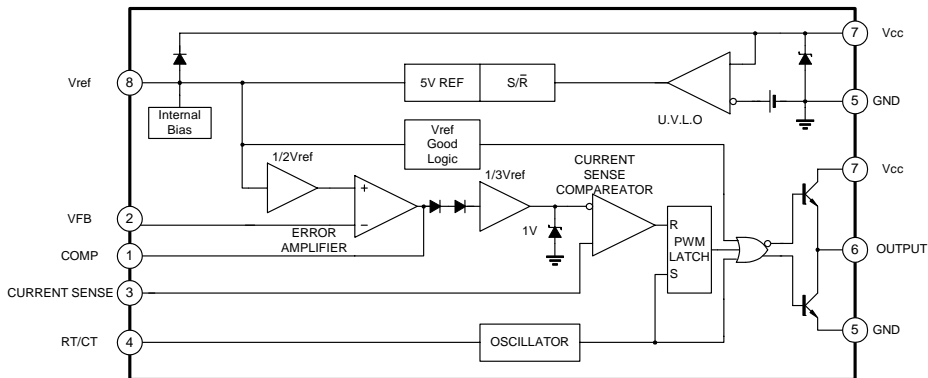

ABSOLUTE MAXIMUM RATINGS($T_a=25^{\circ}\text{C}$)

Characteristic	Symbol	Value	Unit
Supply Voltage(Low Impedance Source)	V _{CC}	30	V
Supply Voltage(I _{CC} <30mA)	V _{CC}	Self Limiting	V
Output Current	I _o	±1	A
Output Energy(capacitive Load)		5	μJ
Analog Inputs(pin 2,3)	V _{I(ANA)}	-0.3 to +6.3	V
Error Amplifier Output Sink Current	I _{SINK(EA)}	10	mA
Power Dissipation	P _D	at T _{amb} ≤25°C 1.0	W
Lead Temperature	T _{lead}	300	°C
Storage Temperature	T _{stg}	-65~+150	°C

Note 1: T_a>25°C,P_D derated with 8mW/°C.

ELECTRICAL CHARACTERISTICS

(0≤T_a≤70°C,V_{CC}=15V,R_T=10kΩ,C_T=3.3nF,unless otherwise specified)

Characteristic	Symbol	Test Conditions	Min	Typ	Max	Units
Reference Section						
Output Voltage	V _{REF}	T _j =25°C,I _o =1mA	4.90	5.00	5.10	V
Line Regulation	ΔV _{REF}	12≤V _{IN} ≤25V		6	20	mV
Load Regulation	ΔV _{REF}	1≤I _o =20mA		6	25	mV
Temperature Stability		(Note 2)		0.2	0.4	mV/°C
Total Output Variation		Line,Load,Temp(note 2)	4.82		5.18	μV
Output Noise Voltage	V _{osc}	10Hz≤f≤10kHz,T _j =25°C (note 2)		50		mV
Long term stability		T _a =25°C,1000Hrs(note 2)		5	25	mV
Output Short Circuit	I _{sc}		-30	-100	-180	mA
Oscillator Section						
Initial Accuracy	f	T _j =25°C	47	52	57	kHz
Voltage Stability	Δf/ΔV _{CC}	12≤V _{CC} ≤25V		0.2	1	%
Temp stability		T _{min} ≤T _A ≤T _{max} (note 2)		5		%
Amplitude	V _{osc}	V _{pin 4} peak to peak		1.7		V
Error Amplifier Section						
Input Voltage	V _{I(EA)}	V _{pin 1} =2.5V	2.42	2.50	2.58	V
Input Bias current	I _{BIAS}			-0.3	-2	μA
A _{VOL}		2 ≤V _o ≤4V	60	90		dB
Unity Gain Bandwidth		T _j =25°C (note 2)	0.7	1		mHz
PSRR		I ₂ ≤V _{CC} ≤25V	60	70		dB
Output Sink Current	I _{sink}	V _{pin 2} =2.7V,V _{pin 1} =1.1V	2	6		mA
Output Source Current	I _{source}	V _{pin 2} =2.3V,V _{pin 1} =5V	-0.5	-0.8		mA
V _{out High}	V _{OH}	V _{pin 2} =2.3V, R _L =15kΩ to GND	5	6		V
V _{out Low}	V _{OL}	V _{pin 2} =2.7V,V _{pin 1} =1.1V		0.7	1.1	V
Current Sense section						
Gain	G _v	(note 3,4)	2.85	3	3.15	V/V
Maximum Input signal	V _{I(MAX)}	V _{pin 1} =5V(note 3)	0.9	1	1.1	V
PSRR		12≤V _{CC} ≤25V		70		dB
Input Bias Current	I _{BIAS}			-2	-10	μA
Delay to Output		V _{pin 3} =0 to 2V		150	300	ns
Output Section						
Output low Level	V _{OL}	I _{sink} =20mA		0.1	0.4	V
		I _{sink} =200mA		1.5	2.2	V

(continued)

Characteristic	Symbol	Test Conditions	Min	Typ	Max	Units
Output High Level	VOH	Isource=20mA	13	13.5		V
		Isource=200mA	12	13.5		V
Rise Time	tR	Tj=25°C, CL=1nF(note 2)		50	150	ns
Fall Time	tF	Tj=25°C, CL=1nF(note 2)		50	150	ns
UVLO Saturation		Vcc=5V, Isink=10mA		0.7	1.2	V
Under-Voltage Lockout Output Section						
Start Threshold	VTH(ST)		14.5	16	17.5	V
Min. Operating Voltage After Turn On	VOPR(min)		8.5	10	11.5	V
PWM Section						
Maximum duty Cycle	D(MAX)		95	07	100	%
Minimum Duty Cycle	D(MIN)				0	%
Total Standby Current						
Start-up Current	IST			0.5	1	mA
Operating Supply Current	ICC(opr)	Vpin 2=Vpin 3=0V		11	17	mA
Vcc Zener Voltage	Vz	Icc=25mA	34			V

note 2: These parameters, although guaranteed, are not 100% tested in production.

note 3: Parameters measured at trip point of latch with Vpin 2=0.

note 4: Gain defined as:

$$A = \frac{\Delta V_{pin 1}}{\Delta V_{pin 3}} ; 0 \leq V_{pin 3} \leq 0.8V$$

note 5: Adjust Vcc above the start threshold before setting at 15V.

OPEN-LOOP LABORATORY TEST CIRCUIT

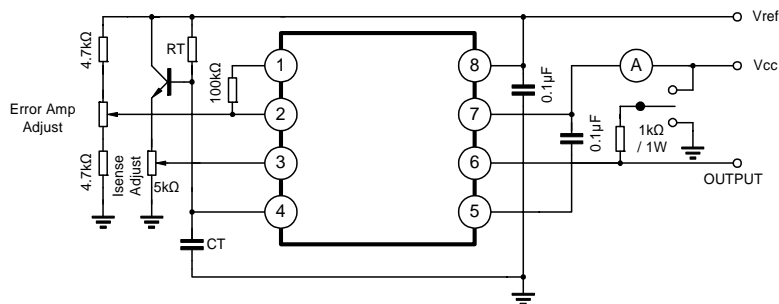

High peak current associated with capacitive loads necessitate careful grounding techniques. Timing and bypass capacitors should be connected close to pin 5

in single point GND. The transistor and 5kΩ potentiometer are used to sample the oscillator waveform and apply an adjustable Ramp to Pin 3.

UNDER-VOLTAGE LOCKOUT

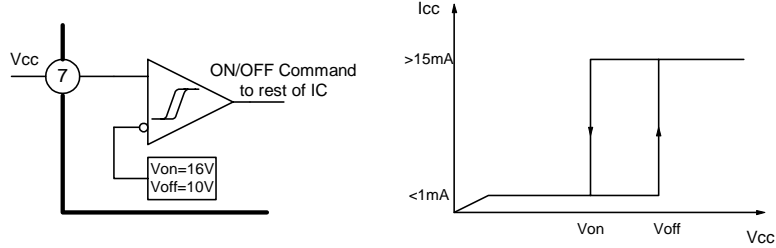

During Under-Voltage Lockout, the output driver is biased to a high impedance state. Pin 6 should be shunt to GND with a bleeder resistor to prevent

activating the power switch with output leakage currents.

ERROR AMPLIFIER CONFIGURATION

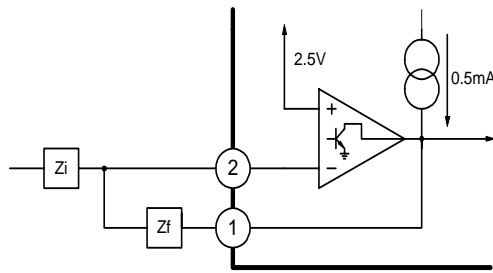

Error amplifier can source or sink up to 0.5mA

CURRENT SENSE CIRCUIT

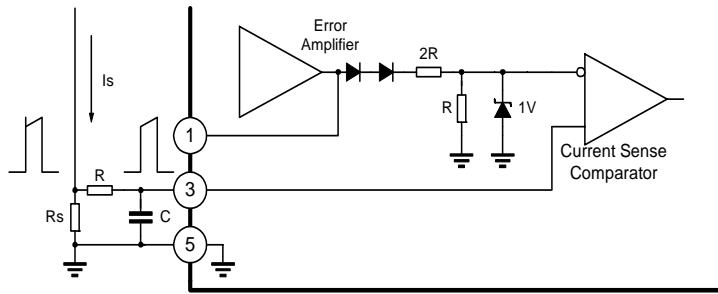

Peak current (I_s) determined by the formula:
 $I_{smax} = 10V/R_s$.
 A small RC filter be required to suppress switch transients.

SLOPE COMPENSATION

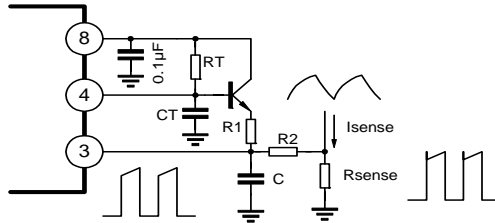

A fraction of the oscillator ramp can be resistively summed with the current sense signal to provide slope compensation for converters requiring duty cycles over

50%. Note that capacitor C, forms a filter with R2 to suppress the leading edge switch spikes.

OSCILLATOR SECTION

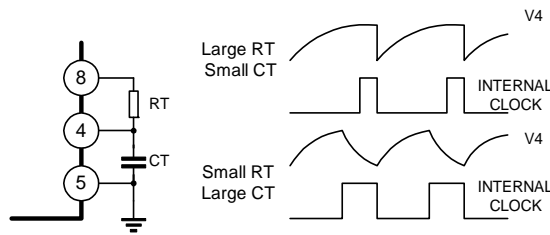

Deadtime VS C_T ($R_T > 5k\Omega$)

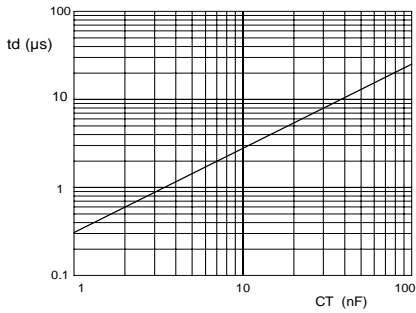

Timing Resistance Vs Frequency

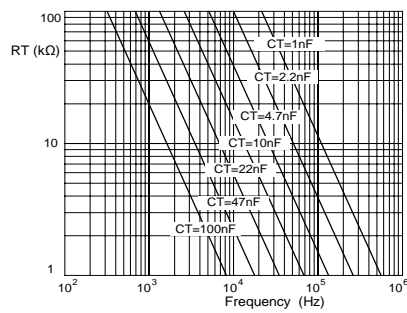

SHUTDOWN TECHNIQUES

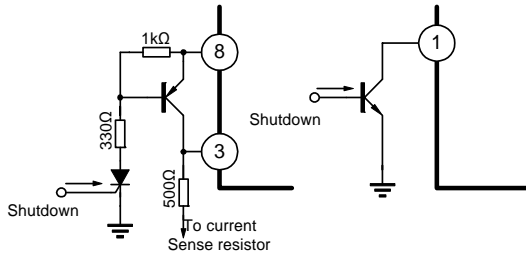

Shutdown UTC3842 can be accomplished by two methods; either raise pin 3 above 1V or pull Pin 1 below a voltage two diode drops above ground. Either method caused the output of PWM comparator to be high(refer to block diagram).The PWM latch is reset dominant so that the output will remain low until the next clock cycle after the shutdown condition at pins a and/or 3 is removed .In one example, an externally latched shut - down may be accomplished by adding an SCR which be reset by cycling Vcc below the lower UVLO threshold. At this point the reference turns off allowing the SCR to reset.

TYPICAL PERFORMANCE CHARACTERISTICS

Vref Temperature Drift

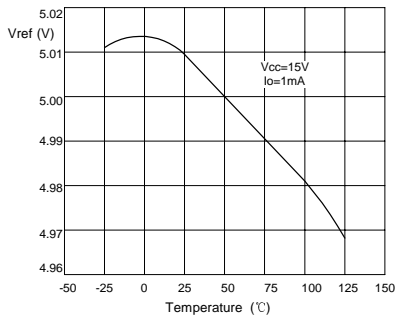

Istart Temperature Drift

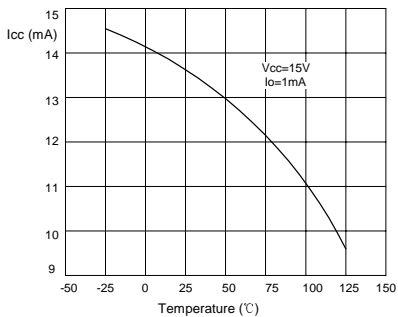
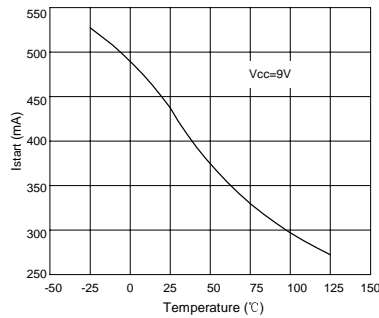

Icc Temperature Drift

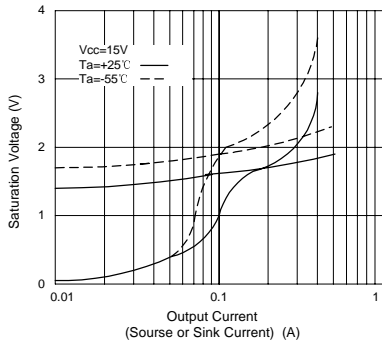

Output Saturation Characteristics

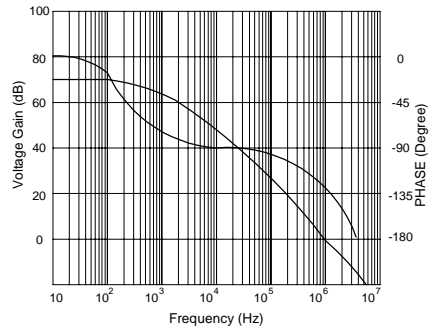

Error Amplifier Open-Loop Frequency Response

PACKAGE DIMENSIONS

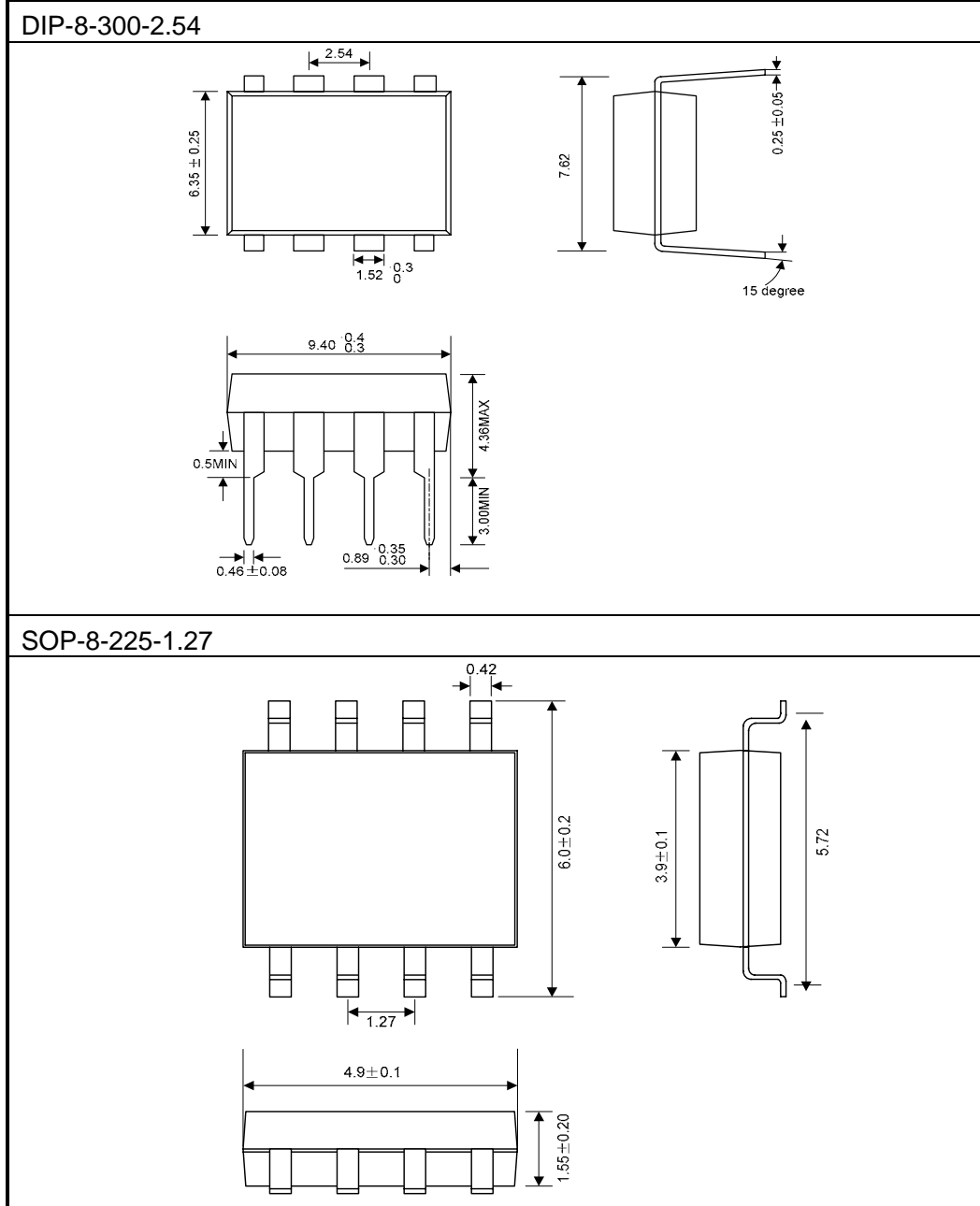

Attach

Revision History

Data	REV	Description	Page
	1.0	Original	
2005.06.09	1.1	Add "PACKAGE OUTLINE DIP-8,SOP-8"	8