

Avantek Products

1 Watt Amplifier

Technical Data

UTO/UTC 1025 Series

Features

- **1 Watt Output**
- **Wide Bandwidth: 20 to 1000MHz**
- **Low Noise Figure: 3 dB (Typ.)**
- **TO-3 and UCS-1P Case Packaging**

Applications

- **Bench Top**
- **UHF/VHF Transmitters**
- **Communications Circuits**
- **Instrumentation**
- **Mobile Radio**

Schematic

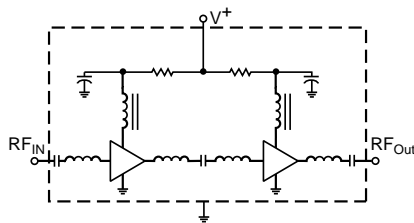

Description

The UTO-1025 1 watt amplifier is a low noise figure, high dynamic range amplifier designed to provide broadband high power output for a wide variety of applications. The amplifier uses two GaAs FET stages with active bias to simultaneously achieve high gain, high output power and low noise figure over the full military temperature range. Applications for this unique amplifier include bench top test sets, receiver front-end, IF gain stages and other broadband applications requiring low noise and high output power. Inputs and outputs are matched to 50 ohms for easy intergration into new and existing systems. Available packaging for this unit is a hermetic TO-3 or the connected UCS-1P case.

Pin Configuration

UTO—TO-3

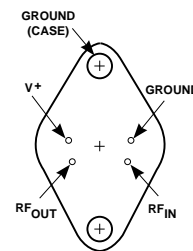

UTC—UCS-1P

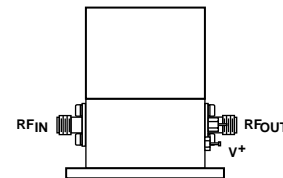

Maximum Ratings

Parameter	Maximum
DC Voltage	+16 Volts
Continuous RF Input Power	+15 dBm ¹
Operating Case Temperature Range UTO	-55 to +85°C
Operating Case Temperature Range UTC	0 to +50°C
Storage Temperature	-62 to +150°C
"R" Series Burn-In Temperature	+85°C

Thermal Characteristics²

θ_{JC}	39/19°C/W ³
Active Transistor Power Dissipation	1.15/3.42 W ³
Junction Temperature Above Case Temperature	45/65°C
MTBF (MIL-HDBK-217E, A _{UF} @ 90°C)	454,100 Hrs. ³

Notes:

1. With no load on output, derate maximum input power (no damage) by 10 dBm.
2. For further information, see Reliability Screening, Pub. 5963-3240E.
3. Values refer to first and second stages, respectively.

Weight: (typical) UTO—14.5 grams; UTC—281 grams

Electrical Specifications

(Measured in 50 Ω system, $V_{CC} = +15V$ unless otherwise noted)

Symbol	Characteristic	Typical $T_C = 25^\circ C$	Guaranteed Specifications		Unit
			$T_C = 0 \text{ to } 50^\circ C$	$T_C = -55 \text{ to } +85^\circ C^1$	
BW	Frequency Range	20-1000	20-1000	20-1000	MHz
GP	Small Signal Gain (Min.)	25.0	23.0	22.0	dB
—	Gain Flatness (Max.)	± 0.7	± 0.7	± 1.0	dB
NF	Noise Figure 20-200 MHz (Max.)	4.0	7.0	8.0	dB
	Noise Figure 200-1000 MHz (Max.)	3.0	4.0	4.5	dB
P_{1dB}	Power Output @ +1 dB Comp. (Min.)	+30.0	+29.0	+28.5	dBm
VSWR	Input VSWR (Max.)	1.6:1	2:0:1	2:0:1	—
VSWR	Output VSWR (Max.)	1.7:1	2:0:1	2:2:1	—
IP_3	Two Tone 3rd Order Intercept Point	+40.0	+37.0	+36.0	dBm
IP_2	Two Tone 2nd Order Intercept Point	+53.0	—	—	dBm
HP_2	One Tone 2nd Harmonic Intercept Point	+60.0	—	—	dBm
I_D	DC Current	500	—	—	mA

Note 1: UTO version only

Typical Performance Over Temperature (@ +15 VDC unless otherwise noted)

Key: +25°C —
+85°C - -
-55°C —

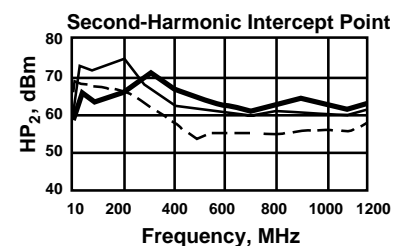
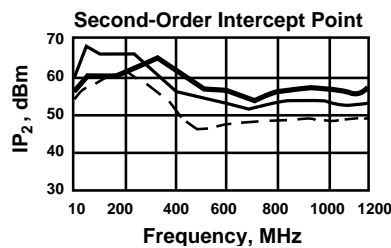
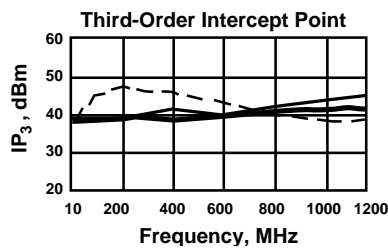
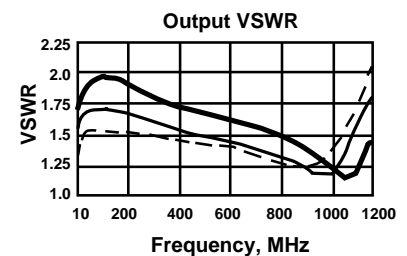
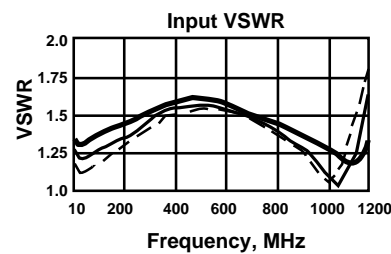
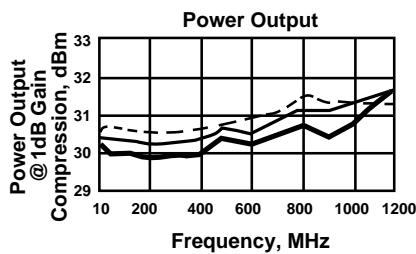
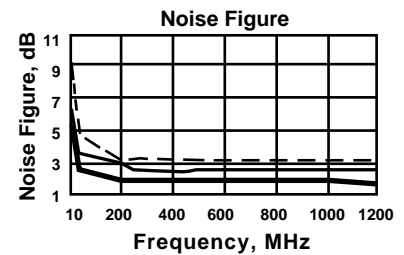
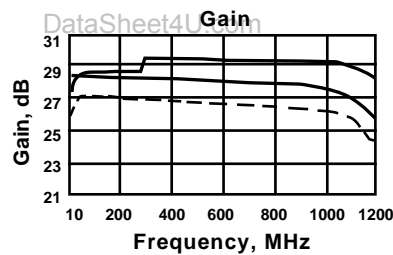

Automatic Network Analyzer Measurements (Typical production unit @ +25°C Case Temperature)
S-Parameters, Magnitudes and Angles, 470 mA **Bias = 15.00 Volts**

FREQ GHz	S ₁₁		S ₂₁		S ₁₂		S ₂₂		K	GPDEL ns	PHASE DEG
	Mag	Ang	dB	Ang	dB	Ang	Mag	Ang			
.010	.13	-44.5	26.3	38.2	-39.8	-6.4	.15	-164.72	2.40	—	—
.020	.11	-22.6	27.2	17.9	-41.6	-10.7	.22	-165.59	2.58	—	—
.030	.10	-12.7	27.5	8.9	-42.0	-9.6	.24	-169.83	2.59	—	—
.040	.10	-7.1	27.6	3.1	-42.2	-9.4	.25	-172.52	2.62	—	—
.050	.10	-3.0	27.6	-1.2	-42.2	-9.4	.26	-174.42	2.61	.79	1.12
.100	.11	9.3	27.7	-16.4	-42.6	-14.3	.26	-179.92	2.67	.79	-2.01
.150	.13	15.6	27.7	-28.4	-42.9	-18.3	.26	177.05	2.75	.63	-2.20
.200	.15	18.8	27.7	-39.7	-42.8	-23.0	.25	173.85	2.70	.59	-1.68
.250	.17	19.6	27.7	-50.8	-43.0	-28.5	.25	171.14	2.75	.58	-1.06
.300	.19	18.7	27.7	-61.8	-42.9	-34.2	.24	169.26	2.70	.58	-.37
.350	.21	16.8	27.6	-72.7	-43.0	-38.7	.22	167.26	2.74	.58	.30
.400	.22	13.5	27.6	-83.5	-43.4	-46.9	.21	165.43	2.85	.59	.88
.450	.23	8.8	27.6	-94.4	-43.3	-50.2	.21	163.95	2.82	.60	1.27
.500	.23	3.9	27.5	-105.4	-43.6	-55.9	.20	162.30	2.93	.60	1.64
.550	.22	-1.8	27.5	-116.3	-43.5	-64.4	.19	160.90	2.94	.61	1.82
.600	.22	-7.7	27.5	-127.4	-43.9	-68.9	.19	159.63	3.07	.61	1.91
.650	.21	-13.5	27.4	-138.6	-43.8	-75.7	.18	158.29	3.07	.63	1.81
.700	.20	-19.8	27.4	-149.8	-44.1	-82.2	.17	157.68	3.23	.64	1.50
.750	.18	-25.9	27.3	-161.3	-44.2	-93.3	.16	158.10	3.34	.64	1.05
.800	.17	-31.8	27.3	-172.9	-44.2	-100.4	.14	159.37	3.40	.65	.46
.850	.15	-37.6	27.3	175.1	-44.5	-109.3	.13	163.20	3.56	.66	-.32
.900	.12	-42.0	27.2	162.8	-45.3	-119.0	.11	171.50	3.98	.66	-1.12
.950	.09	-44.8	27.1	150.1	-46.1	-128.6	.09	-171.43	4.42	.67	-2.01
1.000	.05	-38.7	27.0	136.9	-47.0	-140.5	.09	-144.36	4.99	.68	-3.01
1.050	.03	52.2	26.9	123.2	-47.7	-150.7	.12	-122.25	5.44	—	—
1.100	.08	89.8	26.6	108.9	-48.8	-160.5	.17	-113.05	6.23	—	—
1.150	.16	90.3	26.3	94.2	-49.6	-175.4	.24	-112.07	6.72	—	—
1.200	.24	85.8	25.8	79.1	-51.6	169.9	.30	-115.07	8.31	—	—
1.250	.32	79.6	25.3	63.9	-54.0	160.3	.36	-120.52	10.79	—	—
1.300	.39	71.9	24.5	48.4	-55.3	147.7	.42	-127.45	12.09	—	—
1.350	.46	62.8	23.7	32.7	-58.3	126.0	.47	-135.25	16.63	—	—
1.400	.54	53.2	22.7	16.7	-61.5	95.5	.51	-144.02	23.16	—	—
1.450	.61	43.5	21.4	.5	-63.9	49.1	.56	-153.53	28.99	—	—
1.500	.68	34.8	19.9	-15.5	-63.8	8.6	.61	-163.41	27.08	—	—

Product Options

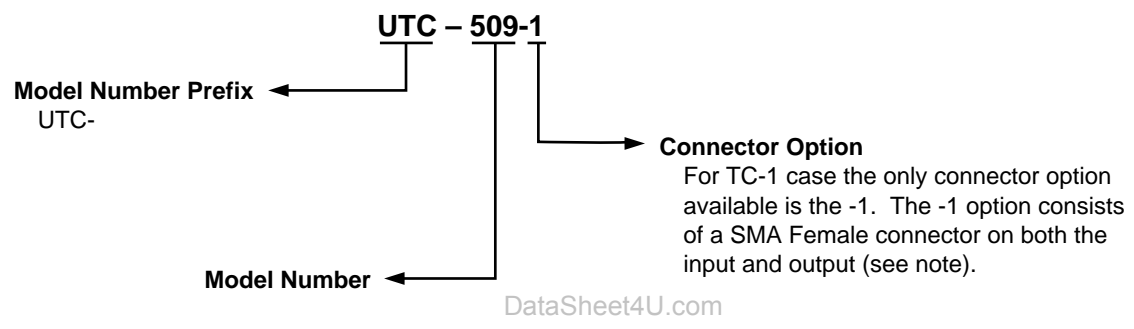
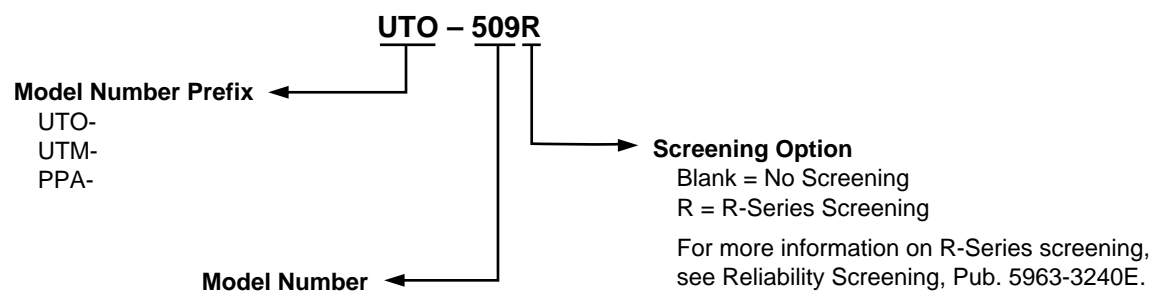

Note: R-Series screening is not available in the TC-1 case as the case is non-hermetic.

Case Drawings TO-3

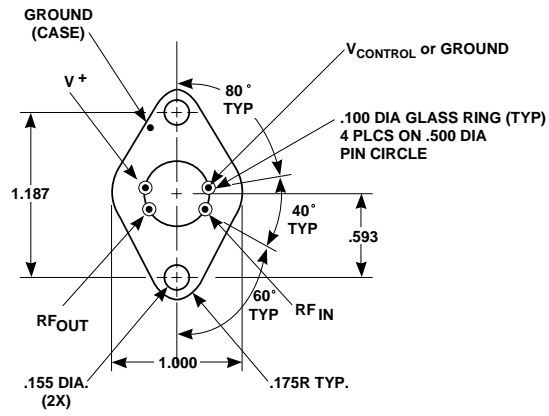
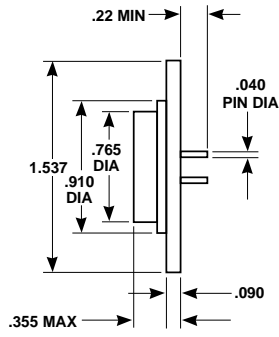

APPROXIMATE WEIGHT 14.5 GRAMS

NOTES (UNLESS OTHERWISE SPECIFIED):

1. DIMENSIONS ARE SPECIFIED IN INCHES
2. TOLERANCES: xx ± .02
xxx ± .010

DataSheet4U.com

**Case Drawings
UCS-1P**

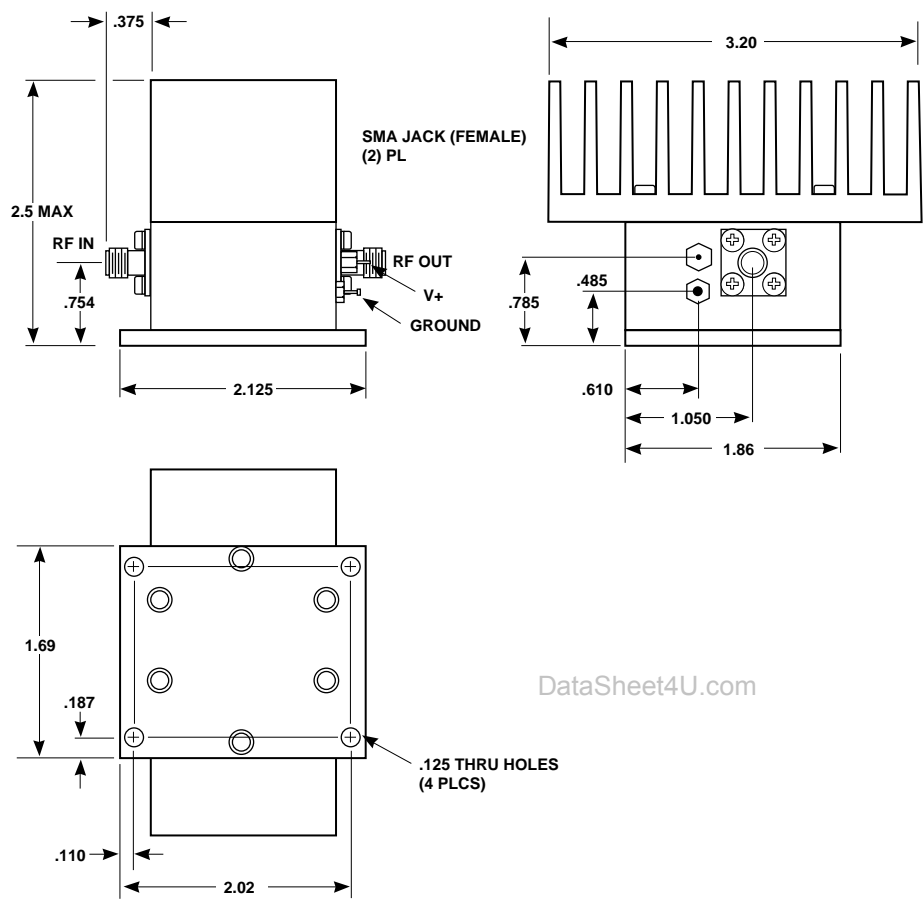

APPROXIMATE WEIGHT 281 GRAMS

- NOTES (UNLESS OTHERWISE SPECIFIED):**
1. DIMENSIONS ARE SPECIFIED IN INCHES
 2. TOLERANCES: xx ± .02
xxx ± .010
 3. THE CONNECTOR OPTION AVAILABLE FOR THE UCS-1P CASE IS THE -1, SMA FEMALE CONNECTORS AT BOTH INPUT AND OUTPUT PORTS.

For more information:

United States*

Europe*

Far East/Australasia: (65) 290-6305

Canada: (416) 206-4725

Japan: (81 3) 3331-6111

*Call your local HP sales office listed in your telephone directory. Ask for a Components representative. www.DataSheet4U.com

Data Subject to Change
Copyright © 1995 Hewlett-Packard Co.

Printed in U.S.A. 5963-2525E (10/94)

et4U.com

DataSheet4U.com

DataSheet4U.com

DataSheet4U.com