

- Tentative Specification
 Preliminary Specification
 Approval Specification

MODEL NO.: V185B1
SUFFIX: LE2

Customer:	
APPROVED BY	SIGNATURE
Name / Title _____	_____
Note	
Please return 1 copy for your confirmation with your signature and comments.	

Approved By	Checked By	Prepared By
Chao-Chun Chung	Roger Huang	Kimi Lin

CONTENTS

1. GENERAL DESCRIPTION	5
1.1 OVERVIEW	5
1.2 FEATURES.....	5
1.3 APPLICATION	5
1.4 GENERAL SPECIFICATIONS	5
1.5 MECHANICAL SPECIFICATIONS	5
2. ABSOLUTE MAXIMUM RATINGS	6
2.1 ABSOLUTE RATINGS OF ENVIRONMENT	6
2.2 ELECTRICAL ABSOLUTE RATINGS	7
2.2.1 TFT LCD MODULE	7
2.2.2 BACK LIGHT UNIT	7
3. ELECTRICAL CHARACTERISTICS	7
3.1 TFT LCD MODULE	7
3.2 Vcc Power Dip Condition	9
3.3 BACKLIGHT UNIT.....	10
3.4 LIGHTBAR Connector Pin Assignment.....	10
4. BLOCK DIAGRAM.....	11
4.1 TFT LCD MODULE	11
4.2 BACKLIGHT UNIT.....	11
5. INPUT TERMINAL PIN ASSIGNMENT	12
5.1 TFT LCD MODULE	12
5.2 LVDS mapping table.....	12
5.3 COLOR DATA INPUT ASSIGNMENT	13
6. INTERFACE TIMING.....	14
6.1 INPUT SIGNAL TIMING SPECIFICATIONS	14
6.2 POWER ON/OFF SEQUENCE.....	16
7. OPTICAL CHARACTERISTICS	17
7.1 TEST CONDITIONS.....	17
7.2 OPTICAL SPECIFICATIONS	17
8. PRECAUTIONS.....	20

8.1 ASSEMBLY AND HANDLING PRECAUTIONS	20
8.2 SAFETY PRECAUTIONS	20
9. DEFINITION OF LABELS.....	21
9.1 CMO MODULE LABEL	21
10. PACKAGING.....	22
10.1 PACKING SPECIFICATIONS.....	22
10.2 PACKING METHOD.....	22
11. MECHANICAL CHARACTERISTICS	23

REVISION HISTORY

Version	Date	Page(New)	Section	Description
Ver. 2.0	Sep,17, 2010	All	All	V185B1-LE2 Approval specification was first issued.

1. GENERAL DESCRIPTION

1.1 OVERVIEW

V185B1-LE2 is an 18.5" TFT Liquid Crystal Display module with WLED Backlight unit and 30pin 1ch-LVDS interface. This module supports 1366 x 768 WXGA mode and can display up to 16.7M colors. The converter module for Backlight is not built in.

1.2 FEATURES

- Contrast ratio 1000:1
- Response time 5ms.
- Brightness 250nits
- Color saturation NTSC70%.
- WXGA (1366 x 768 pixels) resolution.
- DE (Data Enable) only mode.
- LVDS (Low Voltage Differential Signaling) interface.
- RoHS compliance.

1.3 APPLICATION

- TFT LCD Monitor
- TFT LCD TV

1.4 GENERAL SPECIFICATIONS

Item	Specification	Unit	Note
Active Area	409.8 (H) × 230.4(V) (18.5" diagonal)	mm	(1)
Bezel Opening Area	413.4(H) × 234 (V)	mm	
Driver Element	a-Si TFT active matrix	-	-
Pixel Number	1366 x R.G.B. x 768	pixel	-
Pixel Pitch	0.3 (H) × 0.3 (V)	mm	-
Pixel Arrangement	RGB vertical stripe	-	-
Display Colors	16.7M	color	-
Transmissive Mode	Normally White	-	-
Surface Treatment	AG type, 3H hard coating, Haze 25	-	-
Module Power Consumption	9.5(Typ.)	Watt	(2)

1.5 MECHANICAL SPECIFICATIONS

Item	Min.	Typ.	Max.	Unit	Note	
Module Size	Horizontal(H)	429.87	430.37	430.87	mm	(1)
	Vertical(V)	254.1	254.6	255.1	mm	
	Depth(D)		10.5	11	mm	
Weight	-	1530	1580	g	-	

Note (1) Please refer to the attached drawings for more information of front and back outline dimensions.

Note (2) Please refer to sec. 3.1 & 3.3 in this document for more information of power consumption.

2. ABSOLUTE MAXIMUM RATINGS

2.1 ABSOLUTE RATINGS OF ENVIRONMENT

Item	Symbol	Value		Unit	Note
		Min.	Max.		
Storage Temperature	T _{ST}	-20	60	°C	(1)
Operating Ambient Temperature	T _{OP}	0	50	°C	(1), (2)
Shock (Non-Operating)	S _{NOP}	-	50	G	(3), (5)
Vibration (Non-Operating)	V _{NOP}	-	1.0	G	(4), (5)
LCD Cell Life Time	L _{CELL}	50,000	-	Hrs	MTBF based

Note (1) Temperature and relative humidity range is shown in the figure below.

- (a) 90 %RH Max. ($T_a \leq 40$ °C).
- (b) Wet-bulb temperature should be 39 °C Max. ($T_a > 40$ °C).
- (c) No condensation.

Note (2) The temperature of panel display surface area should be 0 °C Min. and 60 °C Max.

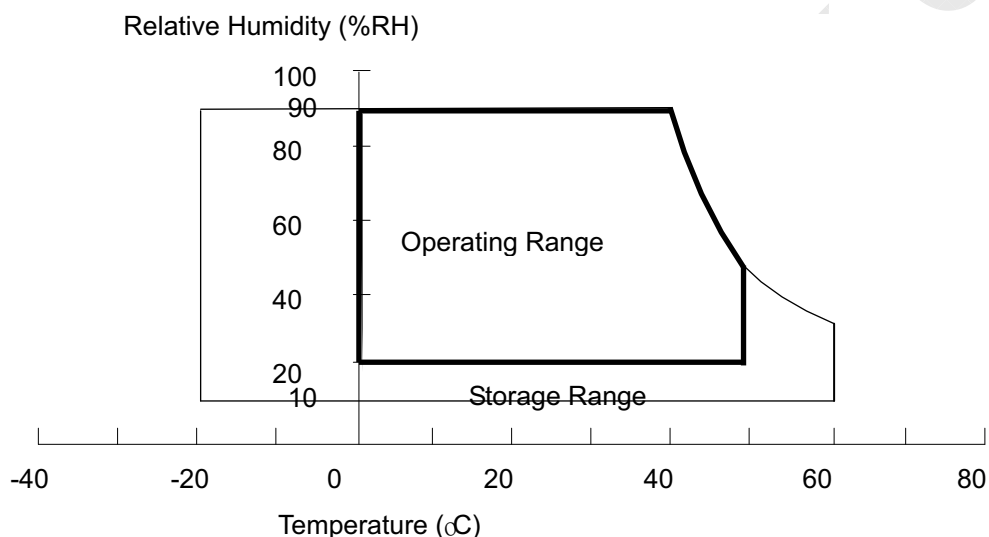

Note (3) 50G,11ms, half sine wave, 1 time for $\pm X$, $\pm Y$, $\pm Z$.

Note (4) 10 ~ 300 Hz, 10min/cycle, 3 cycles each X, Y, Z.

Note (5) At testing Vibration and Shock, the fixture in holding the module has to be hard and rigid enough so that the module would not be twisted or bent by the fixture.

The fixing condition is shown as below:

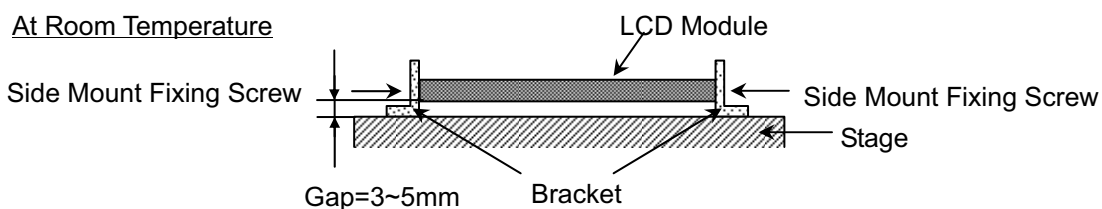

2.2 ELECTRICAL ABSOLUTE RATINGS

2.2.1 TFT LCD MODULE

Item	Symbol	Value		Unit	Note
		Min.	Max.		
Power Supply Voltage	Vcc	-0.3	+6.0	V	(1)
Logic Input Voltage	Vlogic	-0.3	2.7	V	

2.2.2 BACK LIGHT UNIT

Item	Symbol	Value			Unit	Note
		Min.	Typ.	Max.		
LED Forward Current Per Input Pin	I _F	0	20	25	mA	(1), (2) Duty=100%
LED Reverse Voltage Per Input Pin	V _R	---	---	70	V	
LED Pulse Forward Current Per Input Pin	I _{FP}	---	---	80	mA	Pulse Width ≤ 10msec. and Duty ≤ 10%

Note (1) Permanent damage to the device may occur if maximum values are exceeded. Function operation should be restricted to the conditions described under Normal Operating Conditions.

Note (2) Specified values are for input pin of LED light bar at Ta=25±2 °C (Refer to 3.2 and 3.3 for further information).

3. ELECTRICAL CHARACTERISTICS

3.1 TFT LCD MODULE

Ta = 25 ± 2 °C

Parameter	Symbol	Value			Unit	Note
		Min.	Typ.	Max.		
Power Supply Voltage	Vcc	4.5	5.0	5.5	V	-
Ripple Voltage	V _{RP}	-	-	300	mV	-
Rush Current	I _{RUSH}	-	-	3	A	(2)
Power Supply Current	White	-	0.41	0.54	A	(3)a
	Black	-	0.57	0.76	A	(3)b
	Vertical Stripe	-	0.6	0.8	A	(3)c
Power Consumption(without Backlight Unit)	PLCD	-	3.0	4.0	Watt	(4)
LVDS differential input voltage	V _{id}	200	-	600	mV	(5)
LVDS common input voltage	V _{ic}	1.0	1.2	1.4	V	
Logic High Input Voltage	V _{IH}	2.0	-	2.7	V	
Logic Low Input Voltage	V _{IL}	-	-	0.5	V	

Note (1) The ambient temperature is Ta = 25 ± 2 °C.



Note (2) Measurement Conditions:

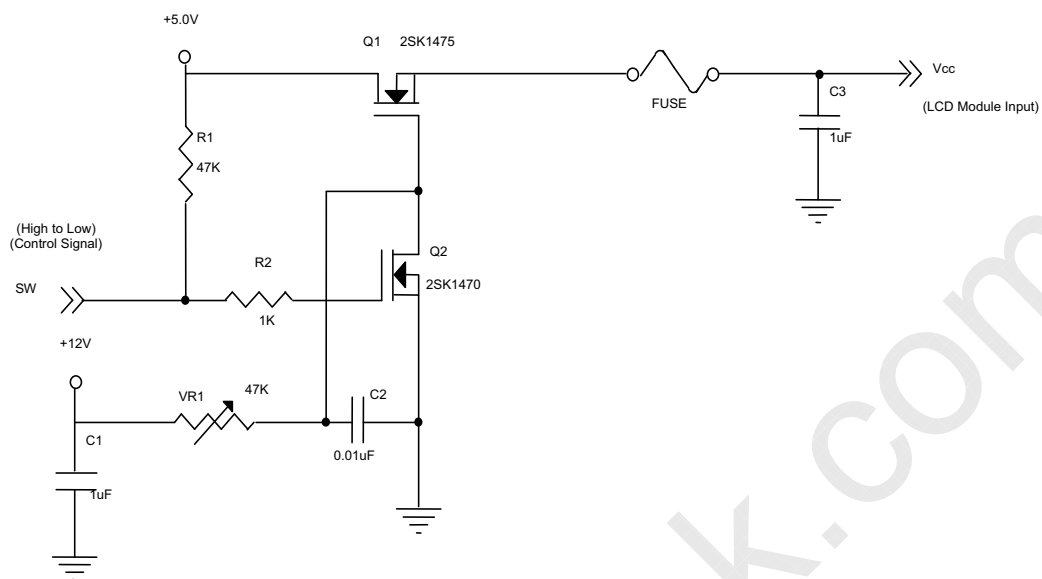

Vcc rising time is 470μs

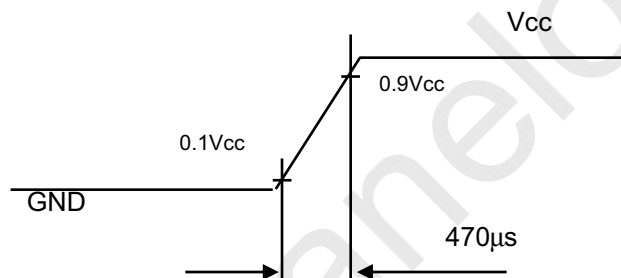

Note (3) The specified power supply current is under the conditions at $V_{CC} = 5.0\text{ V}$, $T_a = 25 \pm 2\text{ }^\circ\text{C}$, $f_v = 60\text{ Hz}$, whereas a power dissipation check pattern below is displayed.

a. White Pattern



Active Area

b. Black Pattern

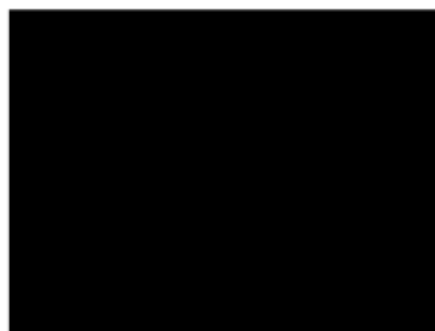

Active Area

c. Vertical Stripe Pattern

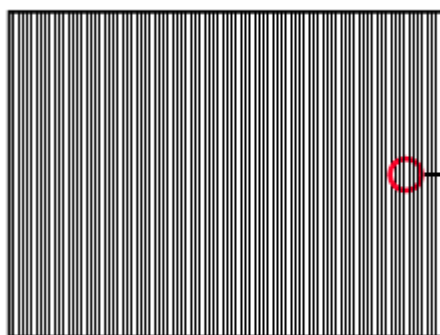

Active Area

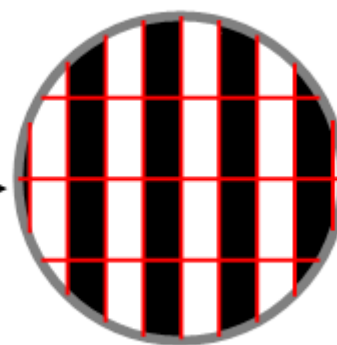

Note (4) The power consumption is specified at the pattern with the maximum current.

Note (5) VID waveform condition

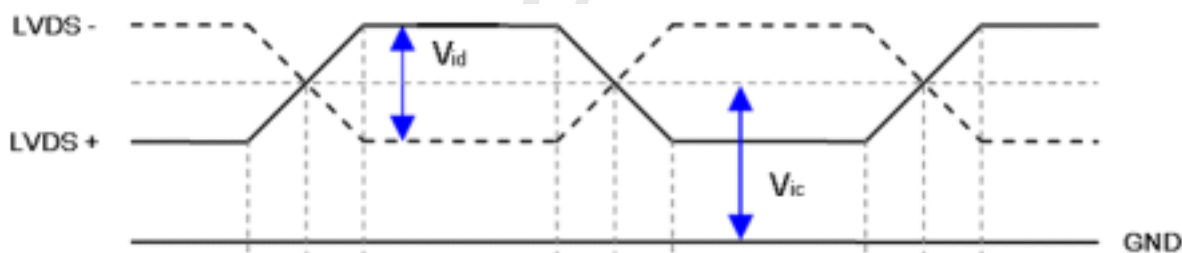

3.2 Vcc Power Dip Condition

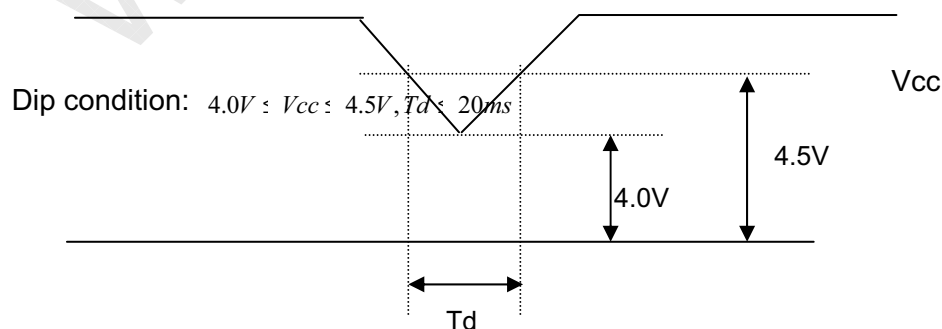

3.3 BACKLIGHT UNIT

 $T_a = 25 \pm 2 \text{ }^\circ\text{C}$

Parameter	Symbol	Value			Unit	Note
		Min.	Typ.	Max.		
LED Light Bar Input Voltage Per Input Pin	V_{PIN}	39.2	43.4	47.6	V	(1), Duty=100%, $I_{PIN}=20\text{mA}$
LED Light Bar Current Per Input Pin	I_{PIN}	0	20	25	mA	(1), (2) Duty=100%
LED Life Time	L_{LED}	30000	---	---	Hrs	(3)
Power Consumption	P_{BL}	---	6.944	7,616	W	(1) Duty=100%, $I_{PIN}=20\text{mA}$

Note (1) LED light bar input voltage and current are measured by utilizing a true RMS multimeter as shown below:

Note (2) $P_{BL} = I_{PIN} \times V_{PIN} \times (8)$ input pins, LED light bar circuit is (14)Series, (8)Parallel.

Note (3) The lifetime of LED is defined as the time when LED packages continue to operate under the conditions at $T_a = 25 \pm 2 \text{ }^\circ\text{C}$ and $I = (20)\text{mA}$ (per chip) until the brightness becomes $\leq 50\%$ of its original value.

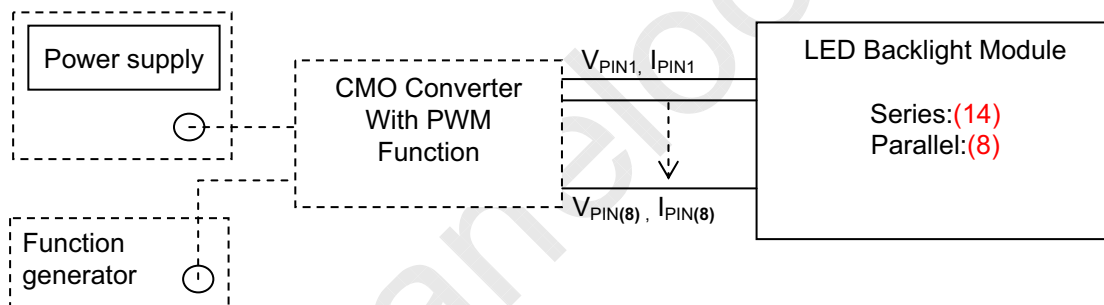

3.4 LIGHTBAR Connector Pin Assignment

Connector: 7083K-F12N-00L (Entry) or EQUIVALENT

CN1

Pin number	Description
1	Cathode of LED string
2	Cathode of LED string
3	Cathode of LED string
4	Cathode of LED string
5	Not connection, this pin should be open
6	VLED
7	VLED
8	Not connection, this pin should be open
9	Cathode of LED string
10	Cathode of LED string
11	Cathode of LED string
12	Cathode of LED string

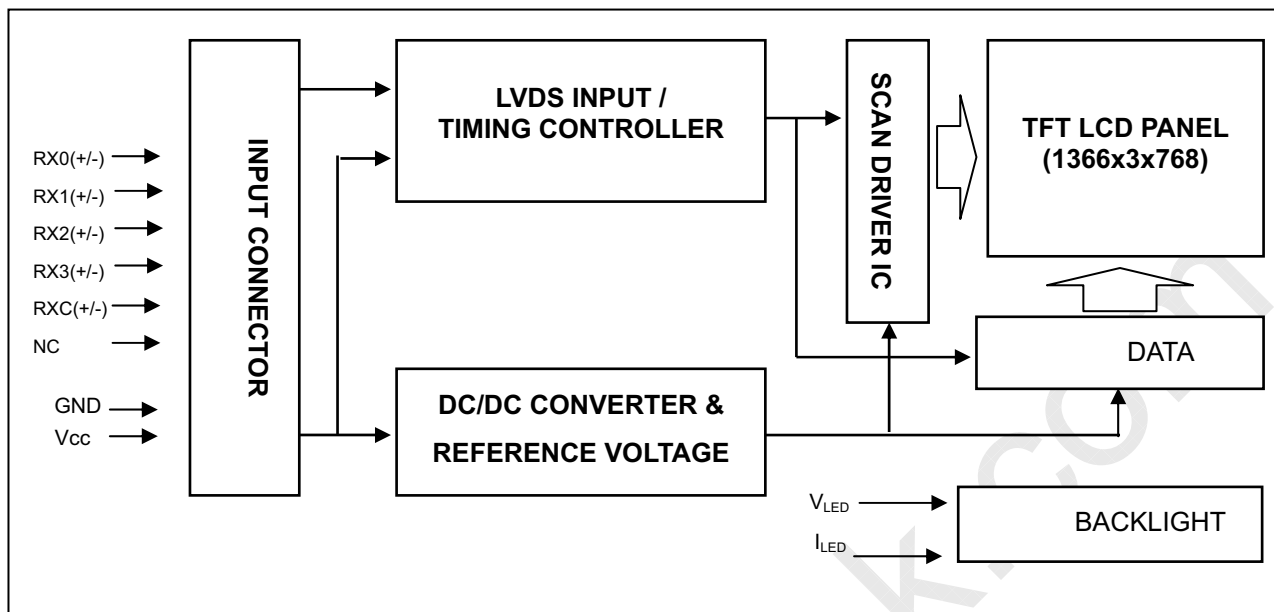
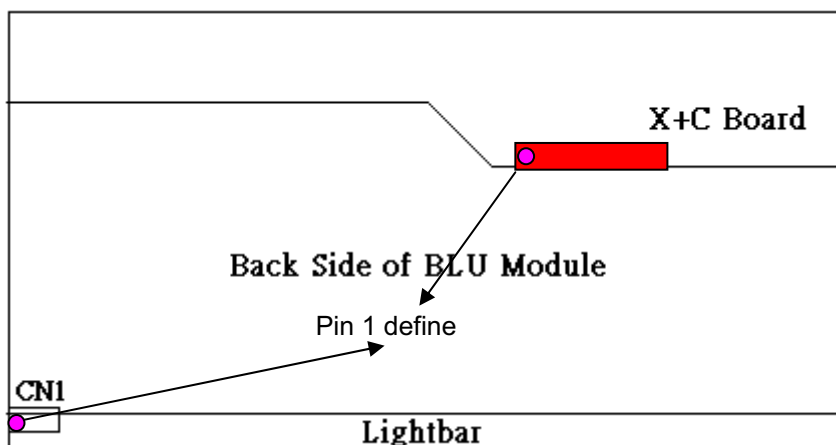
4. BLOCK DIAGRAM
4.1 TFT LCD MODULE

4.2 BACKLIGHT UNIT

5. INPUT TERMINAL PIN ASSIGNMENT

5.1 TFT LCD MODULE

Pin	Name	Description
1	NC	Not connection, this pin should be open.
2	NC	Not connection, this pin should be open.
3	NC	Not connection, this pin should be open.
4	GND	Ground
5	RX0-	Negative LVDS differential data input. Channel 0
6	RX0+	Positive LVDS differential data input. Channel 0
7	GND	Ground
8	RX1-	Negative LVDS differential data input. Channel 1
9	RX1+	Positive LVDS differential data input. Channel 1
10	GND	Ground
11	RX2-	Negative LVDS differential data input. Channel 2
12	RX2+	Positive LVDS differential data input. Channel 2
13	GND	Ground
14	RXCLK-	Negative LVDS differential clock input.
15	RXCLK+	Positive LVDS differential clock input.
16	GND	Ground
17	RX3-	Negative LVDS differential data input. Channel 3
18	RX3+	Positive LVDS differential data input. Channel 3
19	GND	Ground
20	NC	Not connection, this pin should be open.
21	NC	Not connection, this pin should be open.
22	NC	Not connection, this pin should be open.
23	GND	Ground
24	GND	Ground
25	GND	Ground
26	Vcc	+5.0V power supply
27	Vcc	+5.0V power supply
28	Vcc	+5.0V power supply
29	Vcc	+5.0V power supply
30	Vcc	+5.0V power supply

Note (1) Connector Part No.: **STARCONN 093G30-B2001A** or equivalent

Note (2) Mating Wire Cable Connector Part No.: FI-X30H(JAE) or FI-X30HL(JAE)

Note (3) Mating FFC Cable Connector Part No.: 217007-013001 (P-TWO) or JF05X030-1 (JAE)

Note (4) The first pixel is odd.

Note (5) Input signal of even and odd clock should be the same timing.

5.2 LVDS mapping table

LVDS Channel 0	LVDS output	D7	D6	D4	D3	D2	D1	D0
	Data order	G0	R5	R4	R3	R2	R1	R0
LVDS Channel 1	LVDS output	D18	D15	D14	D13	D12	D9	D8
	Data order	B1	B0	G5	G4	G3	G2	G1
LVDS Channel 2	LVDS output	D26	D25	D24	D22	D21	D20	D19
	Data order	DE	NA	NA	B5	B4	B3	B2
LVDS Channel 3	LVDS output	D23	D17	D16	D11	D10	D5	D27
	Data order	NA	B7	B6	G7	G6	R7	R6

5.3 COLOR DATA INPUT ASSIGNMENT

The brightness of each primary color (red, green and blue) is based on the 8-bit gray scale data input for the color. The higher the binary input, the brighter the color. The table below provides the assignment of color versus data input.

Color		Data Signal																						
		Red								Green								Blue						
		R7	R6	R5	R4	R3	R2	R1	R0	G7	G6	G5	G4	G3	G2	G1	G0	B7	B6	B5	B4	B3	B2	B1
Basic Colors	Black	0	0	0	0	0	0	0	0	0	0	0	0	0	0	0	0	0	0	0	0	0	0	0
	Red	1	1	1	1	1	1	1	1	0	0	0	0	0	0	0	0	0	0	0	0	0	0	0
	Green	0	0	0	0	0	0	0	0	1	1	1	1	1	1	1	1	0	0	0	0	0	0	0
	Blue	0	0	0	0	0	0	0	0	0	0	0	0	0	0	0	0	1	1	1	1	1	1	1
	Cyan	0	0	0	0	0	0	0	0	1	1	1	1	1	1	1	1	1	1	1	1	1	1	1
	Magenta	1	1	1	1	1	1	1	1	0	0	0	0	0	0	0	0	1	1	1	1	1	1	1
	Yellow	1	1	1	1	1	1	1	1	1	1	1	1	1	1	1	1	0	0	0	0	0	0	0
	White	1	1	1	1	1	1	1	1	1	1	1	1	1	1	1	1	1	1	1	1	1	1	1
Gray Scale Of Red	Red(0) / Dark	0	0	0	0	0	0	0	0	0	0	0	0	0	0	0	0	0	0	0	0	0	0	
	Red(1)	0	0	0	0	0	0	0	1	0	0	0	0	0	0	0	0	0	0	0	0	0	0	
	Red(2)	0	0	0	0	0	0	1	0	0	0	0	0	0	0	0	0	0	0	0	0	0	0	
	...	:	:	:	:	:	:	:	:	:	:	:	:	:	:	:	:	:	:	:	:	:	:	
	...	:	:	:	:	:	:	:	:	:	:	:	:	:	:	:	:	:	:	:	:	:	:	
	...	:	:	:	:	:	:	:	:	:	:	:	:	:	:	:	:	:	:	:	:	:	:	
	Red(253)	1	1	1	1	1	1	0	1	0	0	0	0	0	0	0	0	0	0	0	0	0	0	
	Red(254)	1	1	1	1	1	1	1	0	0	0	0	0	0	0	0	0	0	0	0	0	0	0	
Red(255)	1	1	1	1	1	1	1	1	0	0	0	0	0	0	0	0	0	0	0	0	0	0		
Gray Scale Of Green	Green(0) / Dark	0	0	0	0	0	0	0	0	0	0	0	0	0	0	0	0	0	0	0	0	0	0	
	Green(1)	0	0	0	0	0	0	0	0	0	0	0	0	0	0	1	0	0	0	0	0	0	0	
	Green(2)	0	0	0	0	0	0	0	0	0	0	0	0	0	1	0	0	0	0	0	0	0	0	
	...	:	:	:	:	:	:	:	:	:	:	:	:	:	:	:	:	:	:	:	:	:	:	
	...	:	:	:	:	:	:	:	:	:	:	:	:	:	:	:	:	:	:	:	:	:	:	
	...	:	:	:	:	:	:	:	:	:	:	:	:	:	:	:	:	:	:	:	:	:	:	
	Green(253)	0	0	0	0	0	0	0	0	1	1	1	1	1	1	0	1	0	0	0	0	0	0	
	Green(254)	0	0	0	0	0	0	0	0	1	1	1	1	1	1	1	0	0	0	0	0	0	0	
Green(255)	0	0	0	0	0	0	0	0	1	1	1	1	1	1	1	1	0	0	0	0	0	0		
Gray Scale Of Blue	Blue(0) / Dark	0	0	0	0	0	0	0	0	0	0	0	0	0	0	0	0	0	0	0	0	0	0	
	Blue(1)	0	0	0	0	0	0	0	0	0	0	0	0	0	0	0	0	0	0	0	0	0	1	
	Blue(2)	0	0	0	0	0	0	0	0	0	0	0	0	0	0	0	0	0	0	0	0	0	1	
	...	:	:	:	:	:	:	:	:	:	:	:	:	:	:	:	:	:	:	:	:	:	:	
	...	:	:	:	:	:	:	:	:	:	:	:	:	:	:	:	:	:	:	:	:	:	:	
	...	:	:	:	:	:	:	:	:	:	:	:	:	:	:	:	:	:	:	:	:	:	:	
	Blue(253)	0	0	0	0	0	0	0	0	0	0	0	0	0	0	0	1	1	1	1	1	1	0	
	Blue(254)	0	0	0	0	0	0	0	0	0	0	0	0	0	0	0	1	1	1	1	1	1	0	
Blue(255)	0	0	0	0	0	0	0	0	0	0	0	0	0	0	0	1	1	1	1	1	1	1		

Note (1) 0: Low Level Voltage, 1: High Level Voltage

6. INTERFACE TIMING

6.1 INPUT SIGNAL TIMING SPECIFICATIONS

The input signal timing specifications are shown as the following table and timing diagram.

Signal	Item	Symbol	Min.	Typ.	Max.	Unit	Note
LVDS Clock	Frequency	F _c	60	76	96	MHz	-
	Period	T _c		13.0		ns	
	Input cycle to cycle jitter	T _{rcj}			200	ns	(1)
	Input Clock to data skew	TLVCCS	-400		+400	ps	(2)
	Spread spectrum modulation range	F _{clk_in_mod}	F _c *98%		F _c *102%	MHz	(3)
	Spread spectrum modulation frequency	F _{SSM}			200	KHz	
Vertical Display Term	Frame Rate	Fr	50	60	75	Hz	T _v =T _v d+T _v b
	Total	T _v	800	806	815	Th	-
	Active Display	T _v d	768	768	768	Th	-
	Blank	T _v b	T _v -T _v d	38	T _v -T _v d	Th	-
Horizontal Display Term	Total	T _h	1500	1560	1570	T _c	T _h =T _h d+T _h b
	Active Display	T _h d	1366	1366	1366	T _c	-
	Blank	T _h b	T _h -T _h d	194	T _h -T _h d	T _c	-

Note: Because this module is operated by DE only mode, Hsync and Vsync input signals are ignored.

INPUT SIGNAL TIMING DIAGRAM

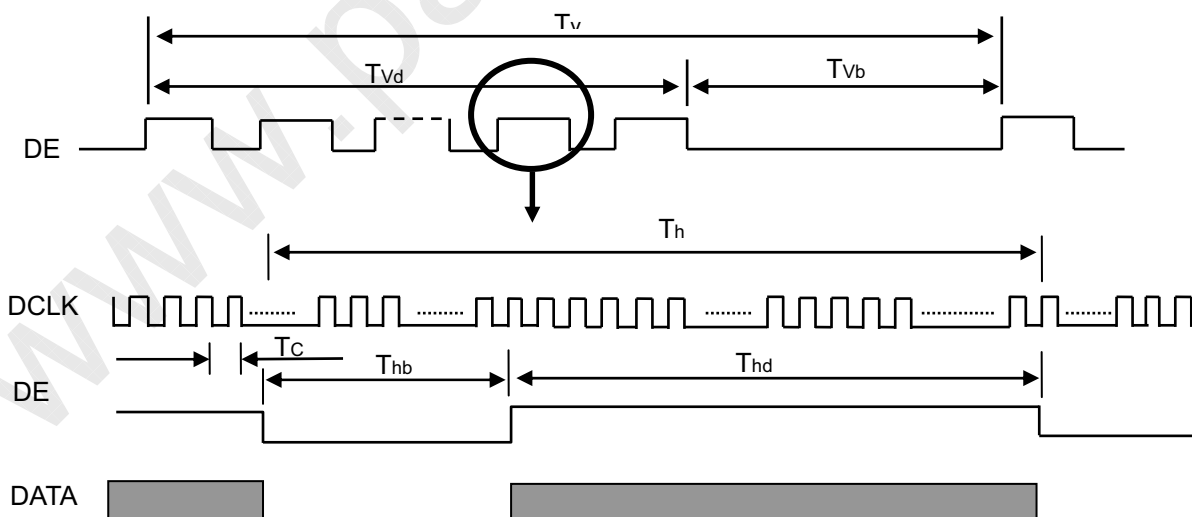

Note (1) The input clock cycle-to-cycle jitter is defined as below figures. $Trcl = |T_1 - T_1|$

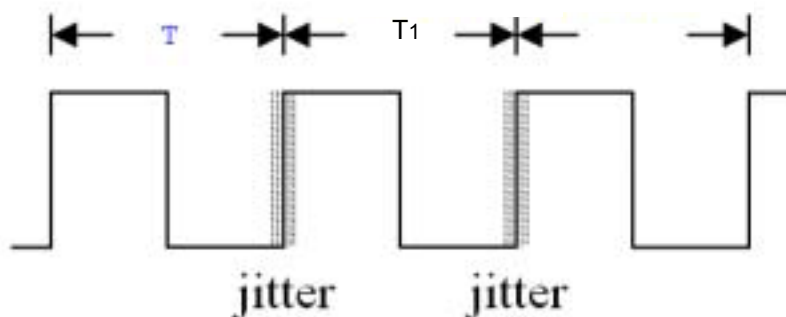

Note (2) Input Clock to data skew is defined as below figures.

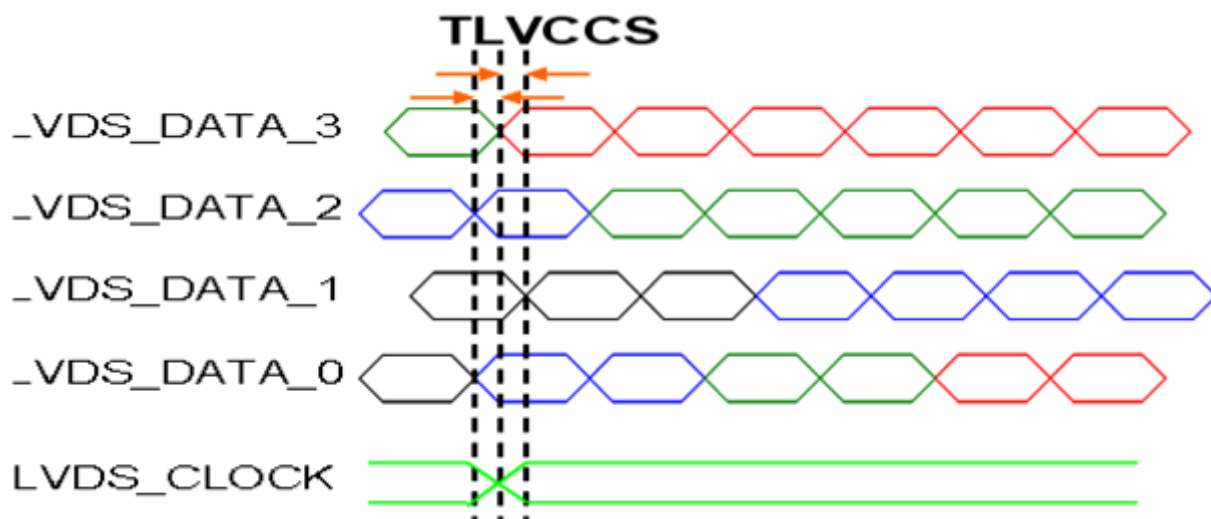

Note (3) The SSCG (Spread spectrum clock generator) is defined as below figures.

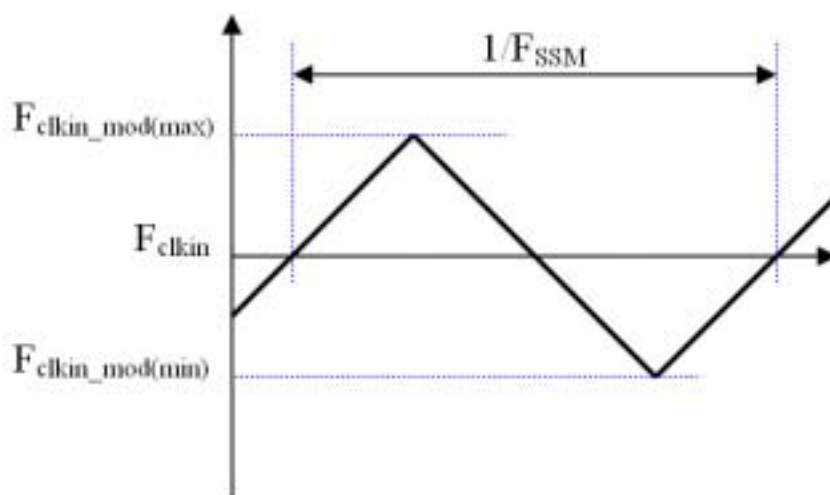

6.2 POWER ON/OFF SEQUENCE

The power sequence specifications are shown as the following table and diagram.

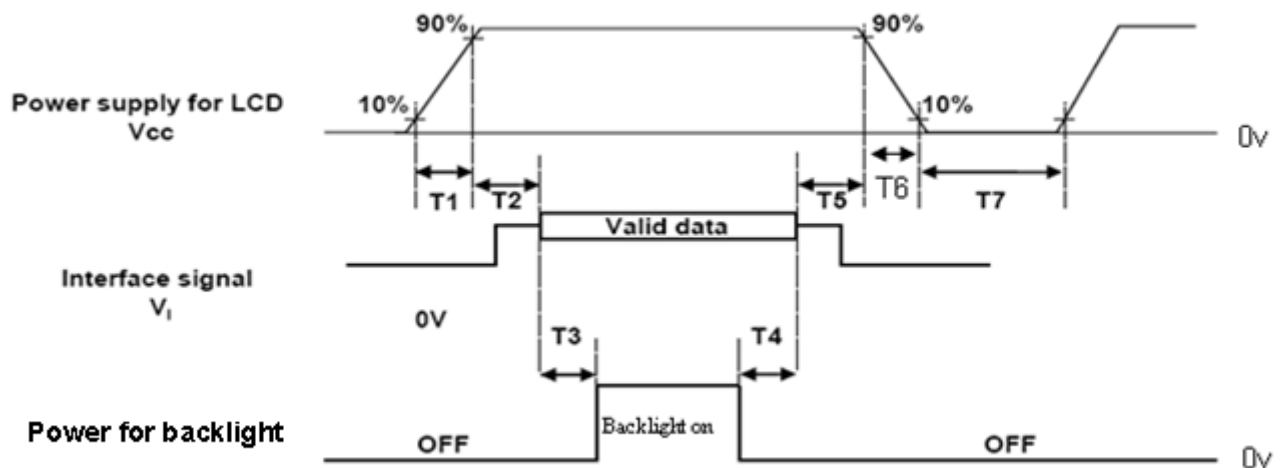

Timing Specifications:

Parameters	Values			Units
	Min	Typ.	Max	
T1	0.5	-	5	ms
T2	0	-	50	ms
T3	450	-	-	ms
T4	90	-	-	ms
T5	0	-	50	ms
T6	5	-	100	ms
T7	500	-	-	ms

Note (1) The supply voltage of the external system for the module input should be the same as the definition of Vcc.

Note (2) When the backlight turns on before the LCD operation of the LCD turns off, the display may momentarily become abnormal screen.

Note (3) In case of VCC = off level, please keep the level of input signals on the low or keep a high impedance.

Note (4) T4 should be measured after the module has been fully discharged between power off and on period.

Note (5) Interface signal shall not be kept at high impedance when the power is on.

Note (6) CMO won't take any responsibility for the products which are damaged by the customers not following the Power Sequence.

Note (7) There might be slight electronic noise when LCD is turned off (even backlight unit is also off). To avoid this symptom, we suggest "Vcc falling timing" to follow "t6 spec".

7. OPTICAL CHARACTERISTICS

7.1 TEST CONDITIONS

Item	Symbol	Value	Unit
Ambient Temperature	Ta	25±2	°C
Ambient Humidity	Ha	50±10	%RH
Supply Voltage	V _{CC}	5	V
Input Signal	According to typical value in "3. ELECTRICAL CHARACTERISTICS"		
LED Light Bar Input Current Per Input Pin	I _{PIN}	20 ± 0.6	mA _{DC}
PWM Duty Ratio	D	100	%
LED Light Bar Test Converter	CMO 27-D041745+ 35-D045785		

7.2 OPTICAL SPECIFICATIONS

The relative measurement methods of optical characteristics are shown in 7.2. The following items should be measured under the test conditions described in 7.1 and stable environment shown in Note (5).

Item	Symbol	Condition	Min.	Typ.	Max.	Unit	Note						
Color Chromaticity (CIE 1931)	Red	Rx	θ _x =0°, θ _y =0° CS-2000	Typ - 0.03	0.639	Typ + 0.03	-	(1), (5)					
		Ry			0.339								
	Green	Gx			0.308								
		Gy			0.616								
	Blue	Bx			0.155								
		By			0.055								
	White	Wx			0.285								
		Wy			0.293								
	Center Luminance of White (Center of Screen)	L _c							200	250	-	cd/m ²	(4), (5)
	Contrast Ratio	CR							700	1000	-	-	(2), (5)
Response Time	T _R	θ _x =0°, θ _y =0°	-	1.3	2.2	ms	(3)						
	T _F		-	3.7	5.8								
White Variation	δW	θ _x =0°, θ _y =0° USB2000	-	-	1.42	-	(5), (6)						
Viewing Angle	Horizontal	θ _x +θ _x -	CR ≥ 10 USB2000	150	170	-	Deg.	(1), (5)					
	Vertical	θ _y +θ _y -				140			160	-			
	Horizontal	θ _x +θ _x -	CR ≥ 5 USB2000	160	178	-							
	Vertical	θ _y +θ _y -				150			170	-			

Note (1) Definition of Viewing Angle (θ_x , θ_y):

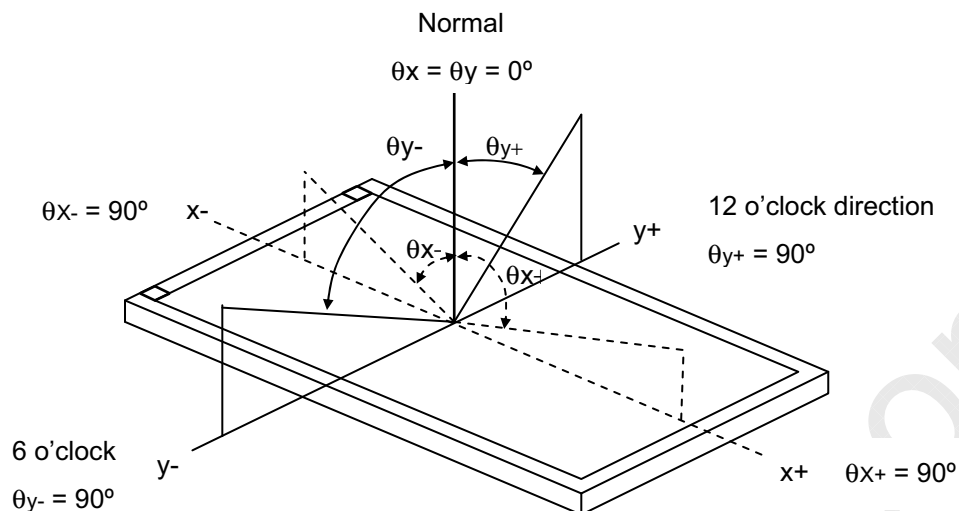

Note (2) Definition of Contrast Ratio (CR):

The contrast ratio can be calculated by the following expression.

$$\text{Contrast Ratio (CR)} = L_{255} / L_0$$

L₂₅₅: Luminance of gray level 255

L₀: Luminance of gray level 0

$$\mathbf{CR = CR (5)}$$

CR (X) is corresponding to the Contrast Ratio of the point X at Figure in Note (6).

Note (3) Definition of Response Time (T_R , T_F):

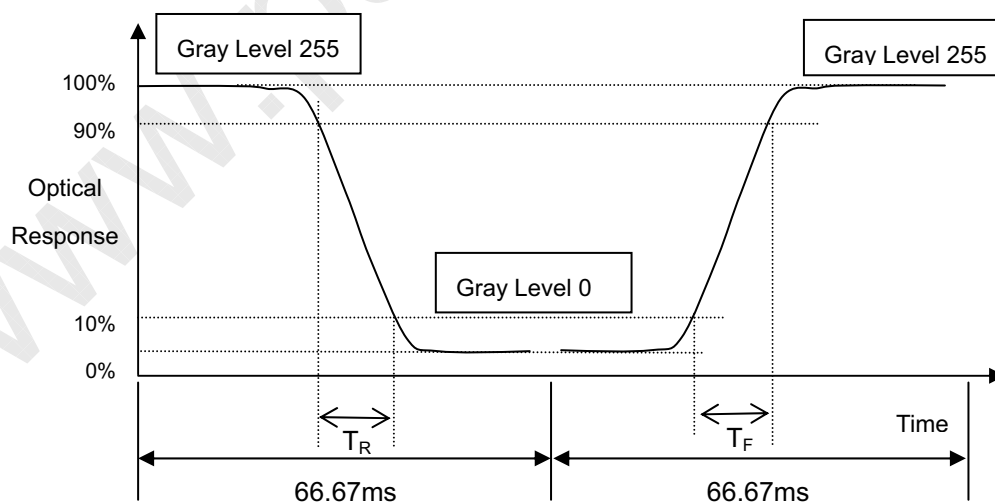

Note (4) Definition of Luminance of White (L_c):

Measure the luminance of gray level 255 at center point

$$L_c = L(5)$$

$L(x)$ is corresponding to the luminance of the point X at Figure in Note (6).

Note (5) Measurement Setup:

The LCD module should be stabilized at given temperature for 20 minutes to avoid abrupt temperature change during measuring. In order to stabilize the luminance, the measurement should be executed after lighting Backlight for 20 minutes in a windless room.

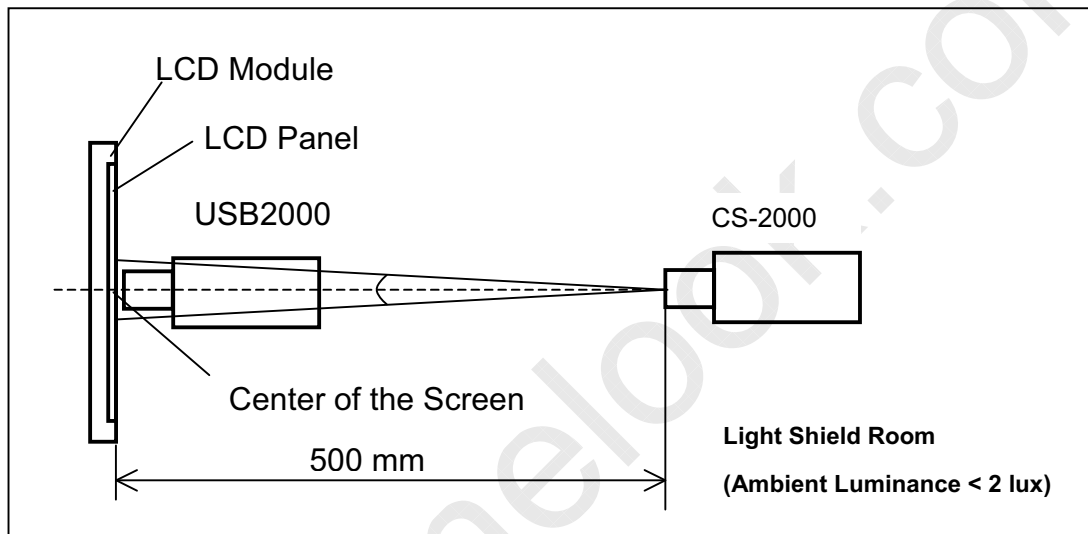

Note (6) Definition of White Variation (δW):

Measure the luminance of gray level 255 at 9 points

$$\delta W = \text{Maximum} [L(1), L(2) \dots L(4), L(9)] / \text{Minimum} [L(1), L(2) \dots L(4), L(9)]$$

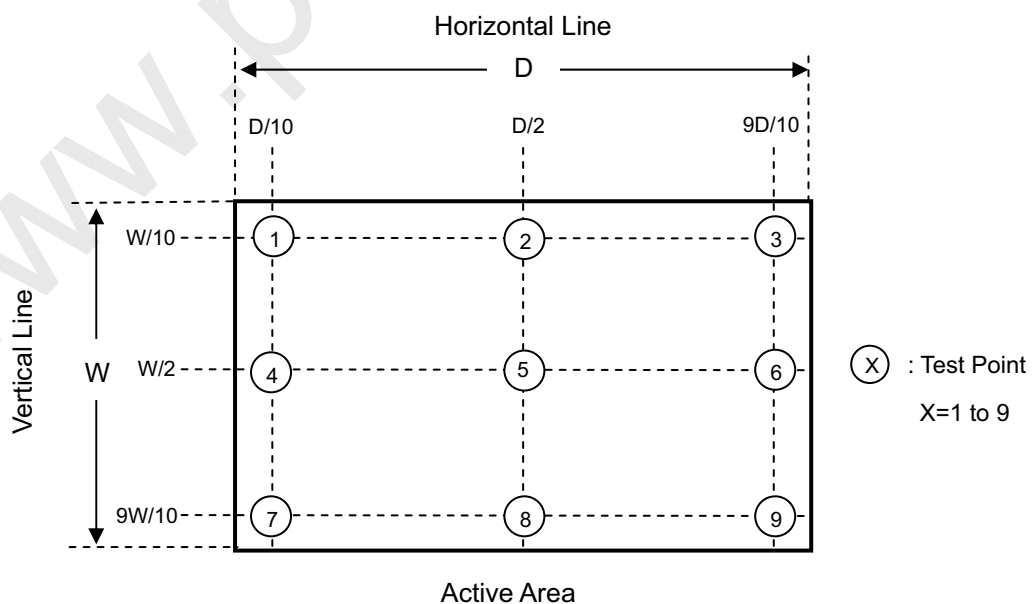

8. PRECAUTIONS

8.1 ASSEMBLY AND HANDLING PRECAUTIONS

- (1) Do not apply rough force such as bending or twisting to the module during assembly.
- (2) To assemble or install module into user's system can be only in clean working areas. The dust and oil may cause electrical short or worsen the polarizer.
- (3) It's not permitted to have pressure or impulse on the module because the LCD panel and Backlight will be damaged.
- (4) Always follow the correct power sequence when LCD module is connecting and operating. This can prevent damage to the CMOS LSI chips during latch-up.
- (5) Do not pull the I/F connector in or out while the module is operating.
- (6) Do not disassemble the module.
- (7) Use a soft dry cloth without chemicals for cleaning, because the surface of polarizer is very soft and easily scratched.
- (8) It is dangerous that moisture come into or contacted the LCD module, because moisture may damage LCD module when it is operating.
- (9) High temperature or humidity may reduce the performance of module. Please store LCD module within the specified storage conditions.
- (10) When ambient temperature is lower than 10°C may reduce the display quality. For example, the response time will become slowly.

8.2 SAFETY PRECAUTIONS

- (1) If the liquid crystal material leaks from the panel, it should be kept away from the eyes or mouth. In case of contact with hands, skin or clothes, it has to be washed away thoroughly with soap.
- (2) After the module's end of life, it is not harmful in case of normal operation and storage.

9. DEFINITION OF LABELS

9.1 CMO MODULE LABEL

The barcode nameplate is pasted on each module as illustration, and its definitions are as following explanation.

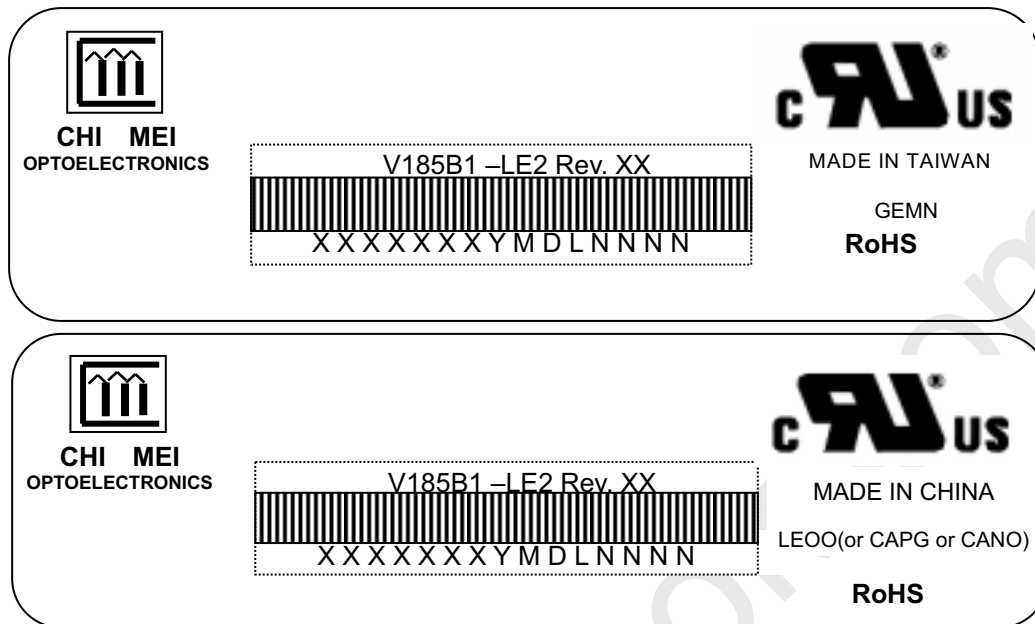

Model Name: V185B1-LE2

Revision: Rev. XX, for example: A0, A1... B1, B2... or C1, C2...etc.

Serial ID: X X X X X X Y M D L N N N N

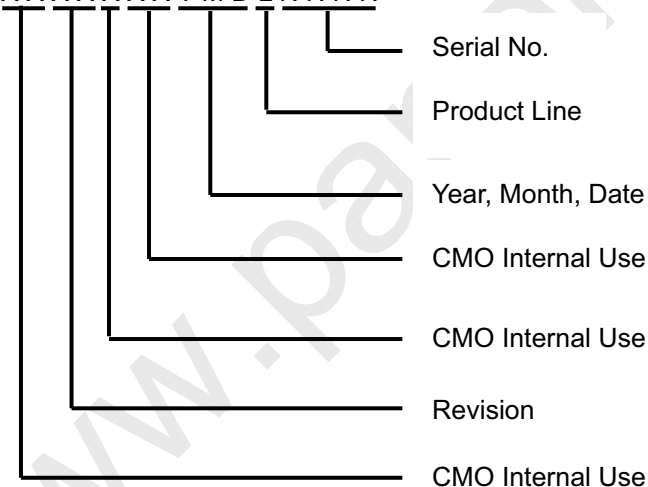

Serial ID includes the information as below:

Manufactured Date:

Year: 2001=1,2002=2,2003=3,2004=4...2010=0,2011=1,2012=2..

Month: 1~9, A~C, for Jan. ~ Dec.

Day: 1~9, A~Y, for 1st to 31st, exclude I ,O, and U.

Revision Code: Cover all the change

Serial No.: Manufacturing sequence of product

Product Line: 1 -> Line1, 2 -> Line 2, ...etc.

10. PACKAGING

10.1 PACKING SPECIFICATIONS

- (1) 12 LCD modules / 1 Box
- (2) Box dimensions: 525(L) X 284 (W) X 360 (H) mm
- (3) Weight: 19.9Kg (12 modules per box)

10.2 PACKING METHOD

- (1) Carton Packing should have no failure in the following reliability test items.

Test Item	Test Conditions	Note
Vibration	ISTA STANDARD Random, Frequency Range: 1 – 200 Hz Top & Bottom: 30 minutes (+Z), 10 min (-Z), Right & Left: 10 minutes (X) Back & Forth 10 minutes (Y)	Non Operation
Dropping Test	1 Corner, 3 Edge, 6 Face, 45.7cm	Non Operation

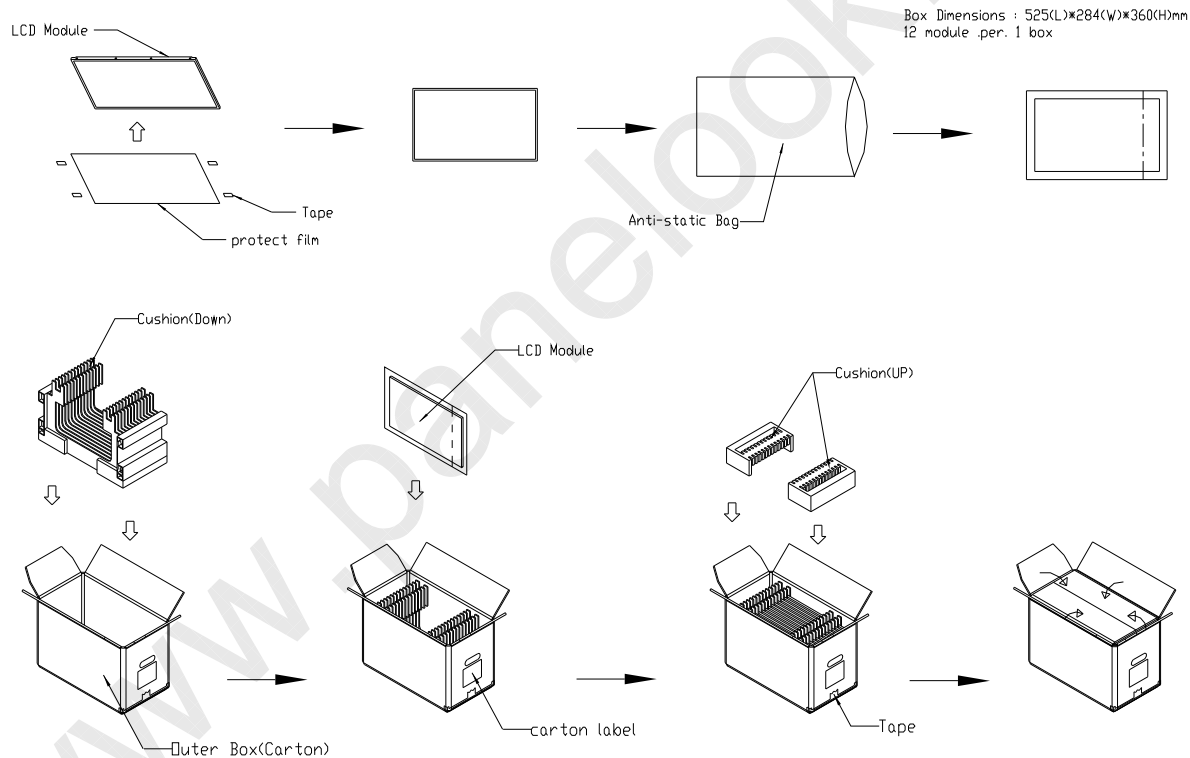
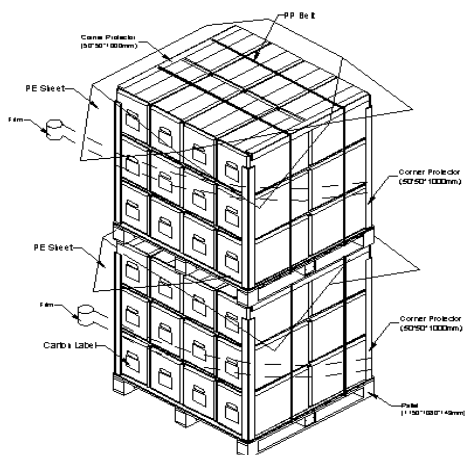

Figure. 10-1 Packing

For ocean shipping

Sea / Land Transportation (40ft HQ Container)



Sea / Land Transportation (40ft Container)

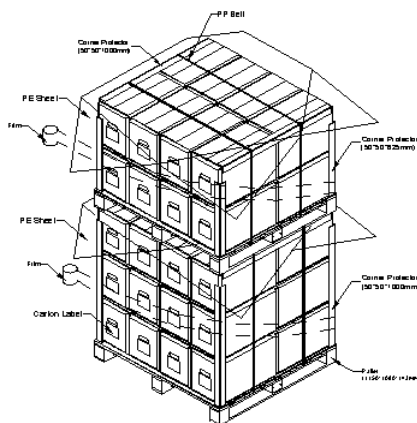

Figure.10-2 Packing

For air transport

Air Transportation

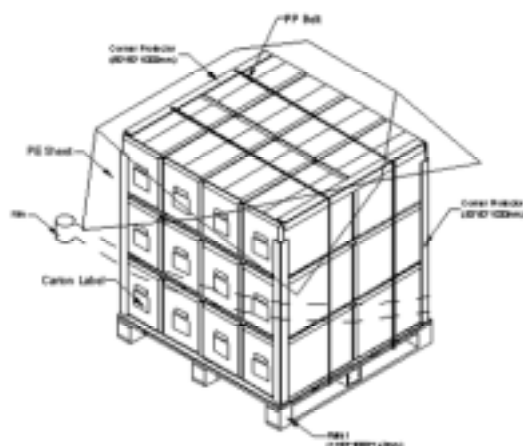

Figure. 10-3 Packing

11. MECHANICAL CHARACTERISTICS

[Refer to the next 2 pages]

Version 2.0

23

Date : 17 Sep 2010

The copyright belongs to CHIMEI InnoLux. Any unauthorized use is prohibited

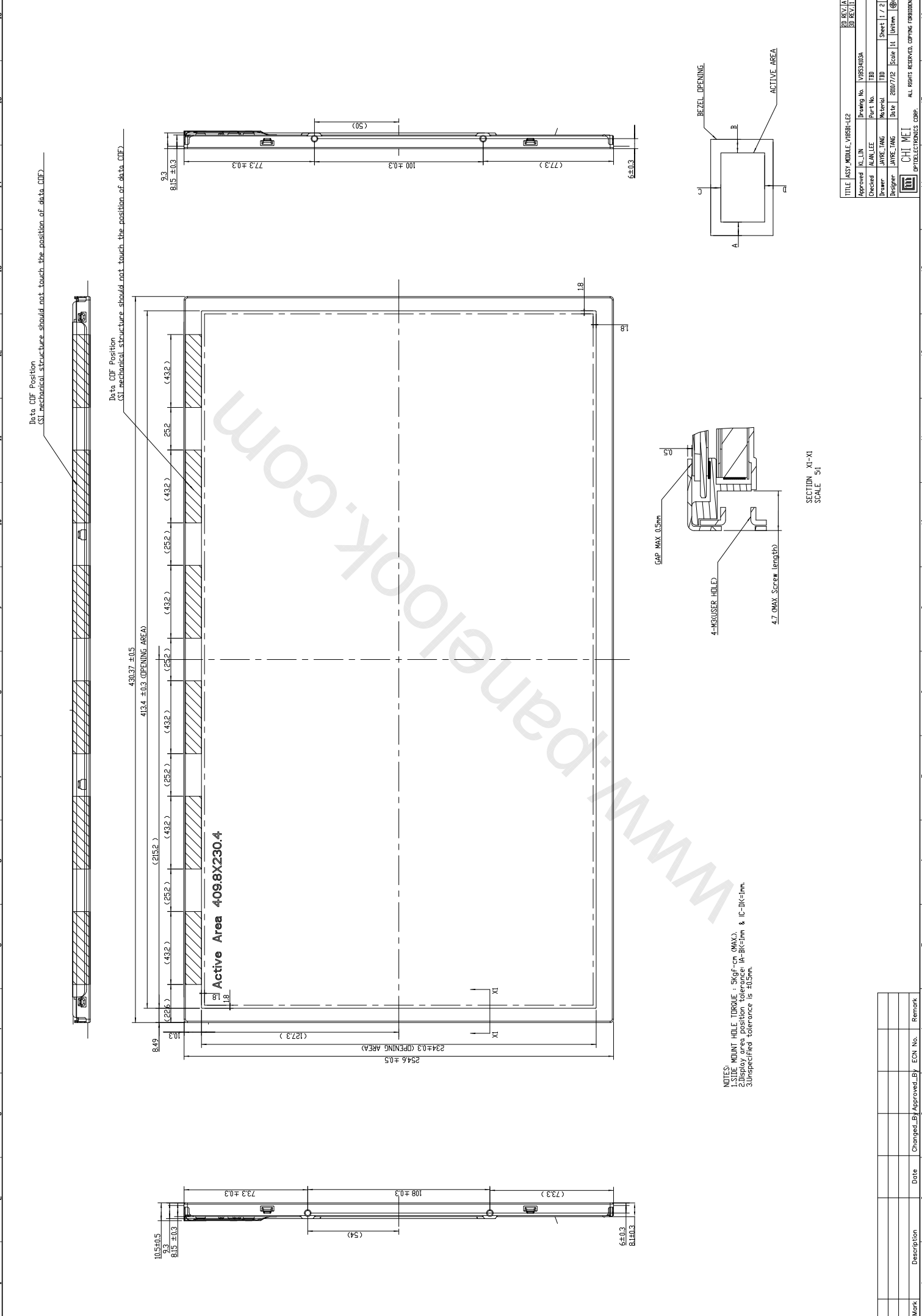

www.panelook.com

NOTES:
 1. MOUNT HOLE TORQUE: 5Kg-cm (MAX).
 2. SIDE MOUNT HOLE TORQUE: 14-30g-cm & (C-2)(C-1mm).
 3. Unspecified tolerance is ±0.5mm.

SECTION XI-XI
 SCALE 5:1

TITLE	ASSEMBLY MODULE_V08B01-LE2	ED REV. / A	14
Approved	RL_CUN	Drawing No.	V08B0103A
Checked	LAN LEE	Part No.	TBD
Drawer	JAVRE_TANG	Material	TBD
Designer	JAVRE_TANG	Date	2007/12
		Scale	1:1
		Sheet	1 / 2
		Total	2
CHI MET		ALL RIGHTS RESERVED. COPING FORBIDDEN.	
CHI ELECTRONICS CORP.			

Mark	Description	Date	Changed By	Approved By	ECN No.	Remark

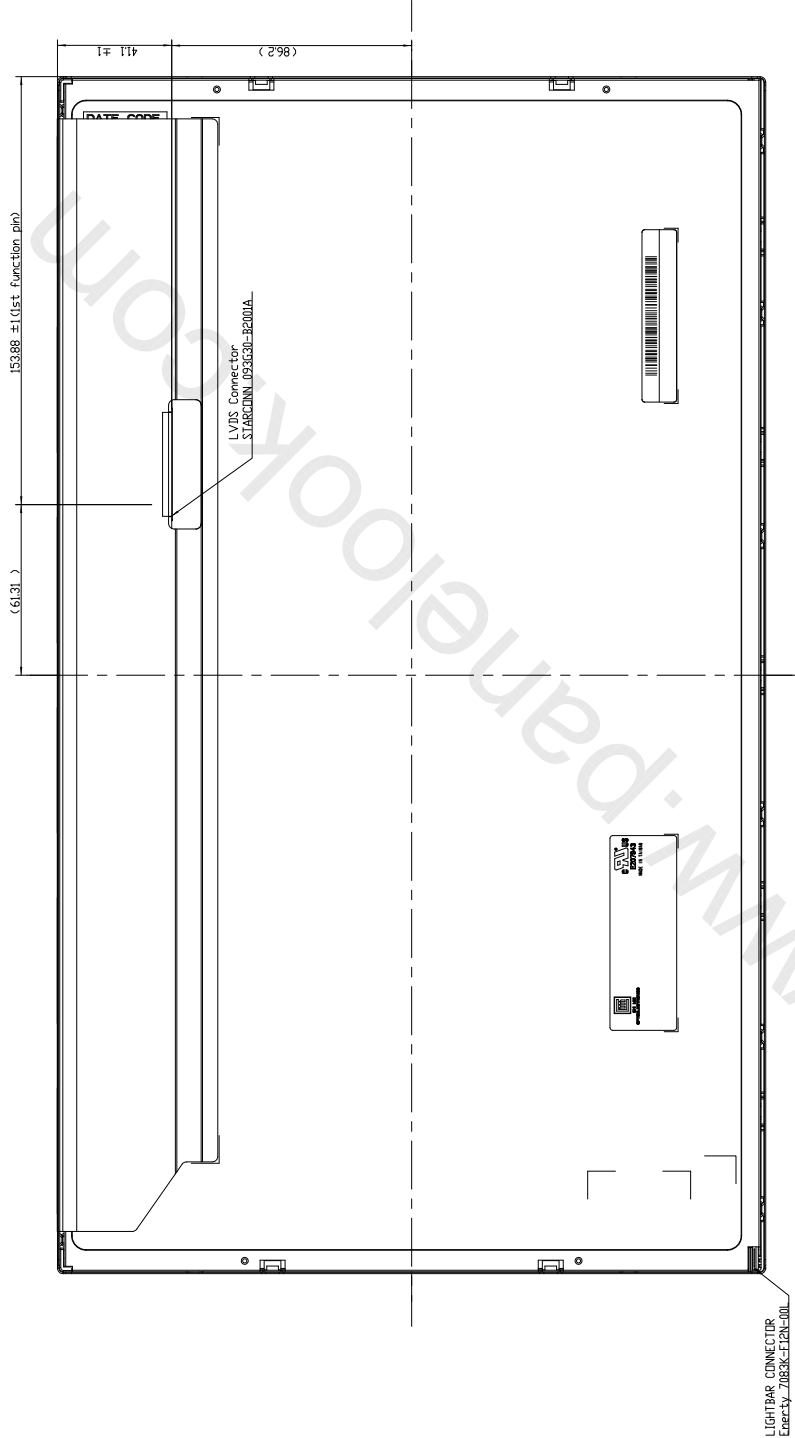

NOTES:
 1. INSIDE MOUNT HOLE TOLERANCE: ±0.05mm (MAX).
 2. INSIDE MOUNT HOLE POSITION TOLERANCE: ±0.1mm & (C-3)C=1mm.
 3. UNSPECIFIED TOLERANCE IS ±0.25mm.

Mark	Description	Date	Changed_By	Approved_By	ECN No.	Remark

TITLE: ASSY MODULE_V085H-LE2		2D REV. / A	
Approved: KJ.LIN	Drawing No. V085H003A	3D REV. / 1	
Checked: JIAN LEE	Part No. TBD		
Drawer: JIANRE.TANG	Material: TBD	Sheet 2 / 2	
Designer: JIANRE.TANG	Date: 2010/7/16	Scale: 1:1	Unit:mm
CHI MEI OPTOELECTRONICS CORP.		ALL RIGHTS RESERVED. COPYING FORBIDDEN.	