

- Tentative Specification
- Preliminary Specification
- Approval Specification

MODEL NO.: V215H1
SUFFIX: LE1

Customer:	
APPROVED BY	SIGNATURE
Name / Title _____	_____
Note	
<hr/> Please return 1 copy for your confirmation with your signature and comments.	

Approved By	Checked By	Prepared By
Chao-Chun Chung	Roger Huang	Vita Wu

CONTENTS

1. GENERAL DESCRIPTION	5
1.1 OVERVIEW	5
1.2 FEATURES	5
1.3 APPLICATION	5
1.4 GENERAL SPECIFICATIONS.....	5
1.5 MECHANICAL SPECIFICATIONS.....	6
2. ABSOLUTE MAXIMUM RATINGS	7
2.1 ABSOLUTE RATINGS OF ENVIRONMENT	7
2.2 PACKAGE STORAGE	8
2.3 ELECTRICAL ABSOLUTE RATINGS.....	8
2.3.1 TFT LCD MODULE.....	8
3. ELECTRICAL CHARACTERISTICS	9
3.1 TFT LCD MODULE	9
3.2 BACKLIGHT CONNECTOR PIN CONFIGURATION	11
3.2.2 LIGHTBAR Connector Pin Assignment.....	12
3.3 LVDS INPUT SIGNAL SPECIFICATIONS.....	12
3.3.1 LVDS DATA MAPPING TABLE.....	13
4. BLOCK DIAGRAM OF INTERFACE.....	13
4.1 TFT LCD MODULE	13
5. INPUT TERMINAL PIN ASSIGNMENT.....	14
5.1 TFT LCD Module Input.....	14
5.2 BLOCK DIAGRAM OF INTERFACE	15
5.3 LVDS INTERFACE.....	17
5.4 COLOR DATA INPUT ASSIGNMENT.....	18
6. INTERFACE TIMING.....	19
6.1 INPUT SIGNAL TIMING SPECIFICATIONS.....	19
6.2 POWER ON/OFF SEQUENCE	22
7. OPTICAL CHARACTERISTICS.....	24
7.1 TEST CONDITIONS	24
7.2 OPTICAL SPECIFICATIONS	25

8. PRECAUTIONS.....	28
8.1 ASSEMBLY AND HANDLING PRECAUTIONS.....	28
8.2 SAFETY PRECAUTIONS.....	28
9. DEFINITION OF LABELS.....	29
9.1 CMI MODULE LABEL.....	29
10. PACKAGING.....	30
10.1 PACKAGING SPECIFICATIONS.....	30
10.2 PACKAGING METHOD.....	30
11. MECHANICAL CHARACTERISTIC.....	32

REVISION HISTORY

Version	Date	Page(New)	Section	Description
Ver. 2.0	Apr., 20, 10	All	All	V215H1-LE1 Approval Specifications was first issued.
Ver. 2.1	Sept., 22, 10	All	All	Approval Specifications Change Spec. Format.
Ver. 2.2	Dec., 06, 10	Page 5	1.4	Modify pixel pitch

1. GENERAL DESCRIPTION

1.1 OVERVIEW

V215H1-LE2 is a 21.5" TFT Liquid Crystal Display module with WLED Backlight unit and 30 pins 2ch-LVDS interface. This module supports 1920 x 1080 Full HDTV format and can display up to 16.7M colors. The converter module for Backlight is not built in.

1.2 FEATURES

- Extra-wide viewing angle.
- High contrast ratio.
- Fast response time.
- High color saturation.
- Full HD (1920 x 1080 pixels) resolution.
- DE (Data Enable) only mode.
- LVDS (Low Voltage Differential Signaling) interface.
- RoHS compliance.

1.3 APPLICATION

- Standard Living Room TVs
- MFM Application

1.4 GENERAL SPECIFICATIONS

Item	Specification	Unit	Note
Active Area	476.64(H) x 268.11(V) (21.53" diagonal)	mm	(1)
Bezel Opening Area	479.8 (H) x 271.3 (V)	mm	
Driver Element	a-si TFT active matrix	–	–
Pixel Number	1920 x R.G.B. x 1080	pixel	–
Pixel Pitch(Sub Pixel)	0.08275(H) x 0.24825(V)	mm	–
Pixel Arrangement	RGB vertical stripe	–	–
Power consumption	15.28W (LVDS input Power 5.3W + LED Backlight Power 9.98 W)	Watt	(2)
Display Colors	16.7M	color	–
Display Operation Mode	Transmissive mode / Normally white	–	–
Surface Treatment	Anti-Glare coating (Haze 25%)	–	(3)

Note (1) Please refer to the attached drawings in chapter 9 for more information about the front and back outlines.

Note (2) Please refer sec 3.1 and 3.2 for more information of Power consumption

Note (3) The spec. of the surface treatment is temporarily for this phase. CMI reserves the rights to change this feature.

1.5 MECHANICAL SPECIFICATIONS

Item		Min.	Typ.	Max.	Unit	Note
Module Size	Horizontal (H)	495.1	495.6	496.1	mm	(1)
	Vertical (V)	291.7	292.2	292.7	mm	(1)
	Depth (D)	11.0	11.5	12.0	mm	(1)
Weight		—	2010	2060	g	—

Note (1) Please refer to the attached drawings for more information of front and back outline dimensions.

2. ABSOLUTE MAXIMUM RATINGS

2.1 ABSOLUTE RATINGS OF ENVIRONMENT

Item	Symbol	Value		Unit	Note
		Min.	Max.		
Storage Temperature	TST	-20	+60	°C	(1)
Operating Ambient Temperature	TOP	0	50	°C	(1), (2)
Shock (Non-Operating)	SNOP	—	50	G	(3), (5)
Vibration (Non-Operating)	VNOP	—	1.0	G	(4), (5)

Note (1) Temperature and relative humidity range is shown in the figure below.

- (a) 90 %RH Max. ($T_a \leq 40$ °C).
- (b) Wet-bulb temperature should be 39 °C Max. ($T_a > 40$ °C).
- (c) No condensation.

Note (2) The maximum operating temperature is based on the test condition that the surface temperature of display area is less than or equal to 65 °C with LCD module alone in a temperature controlled chamber. Thermal management should be considered in final product design to prevent the surface temperature of display area from being over 65 °C. The range of operating temperature may degrade in case of improper thermal management in final product design.

Note (3) 11 ms, half sine wave, 1 time for $\pm X$, $\pm Y$, $\pm Z$.

Note (4) 10 ~ 200 Hz, 10 min, 1 time each X, Y, Z.

Note (5) At testing Vibration and Shock, the fixture in holding the module has to be hard and rigid enough so that the module would not be twisted or bent by the fixture.

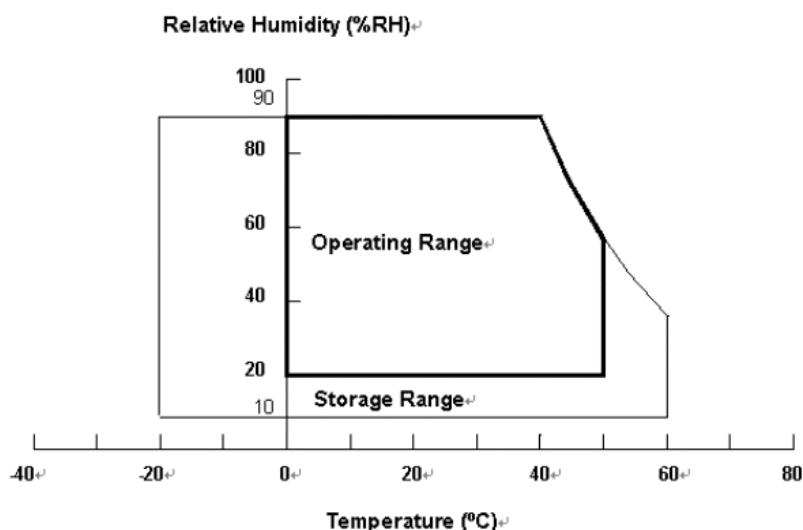

2.2 PACKAGE STORAGE

When storing modules as spares for a long time, the following precaution is necessary.

- (a) Do not leave the module in high temperature, and high humidity for a long time, It is highly recommended to store the module with temperature from 0 to 35 °C at normal humidity without condensation.
- (b) The module shall be stored in dark place. Do not store the TFT-LCD module in direct sunlight or fluorescent light.

2.3 ELECTRICAL ABSOLUTE RATINGS

2.3.1 TFT LCD MODULE

Item	Symbol	Value		Unit	Note
		Min.	Max.		
Power Supply Voltage	VCC	-0.3	13.5	V	(1)
Logic Input Voltage	VIN	-0.3	3.6	V	

3. ELECTRICAL CHARACTERISTICS

3.1 TFT LCD MODULE

(Ta = 25 ± 2 °C)

Parameter	Symbol	Value			Unit	Note	
		Min.	Typ.	Max.			
Power Supply Voltage	V _{CC}	4.5	5.0	5.5	V	(1)	
Rush Current	I _{RUSH}	—	—	3	A	(2)	
Power consumption	P _T	—	5.3	6.3		(3)	
Power Supply Current	White Pattern	—	-	0.51	0.61	A	(4)
	Vertical Strip(MNT)	—	-	1.06	1.26	A	
	Black Pattern	—	-	1.05	1.26	A	
LVDS interface	Differential Input High Threshold Voltage	V _{LVTH}	+100	—	—	mV	(5)
	Differential Input Low Threshold Voltage	V _{LVTL}	—	—	-100	mV	
	Common Input Voltage	V _{CM}	1.0	1.2	1.4	V	
	Differential input voltage (single-end)	V _{ID}	200	—	600	mV	

Note (1) The module should be always operated within the above ranges.

Note (2) Even though Inrush current is over the specified value, there is no problem if I²T of fuse Spec is satisfied. The measurement condition is shown as bellowing.

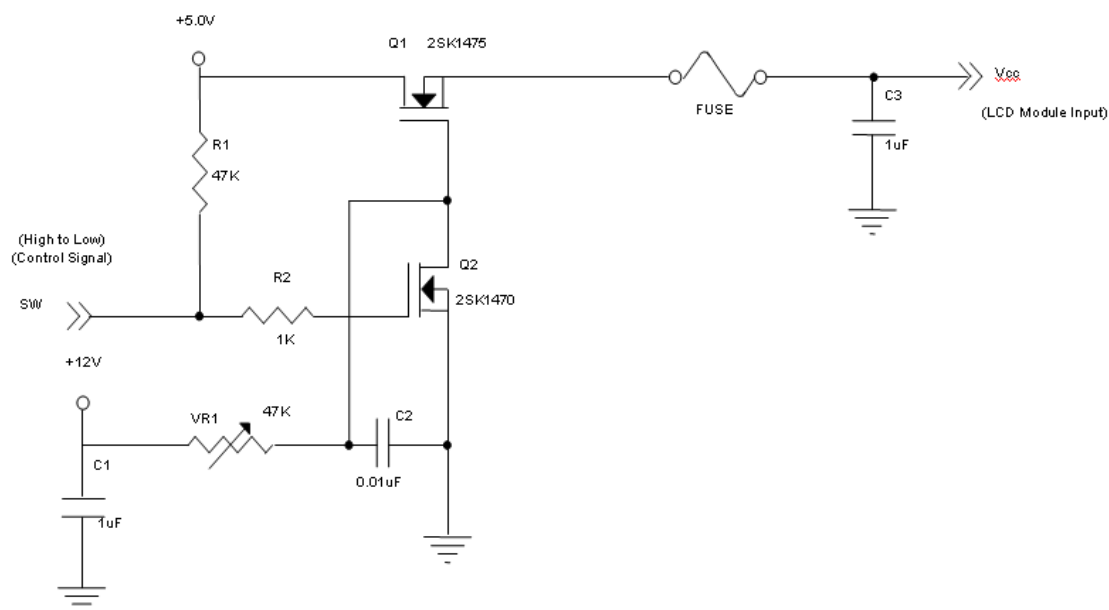

Vcc rising time is 470us

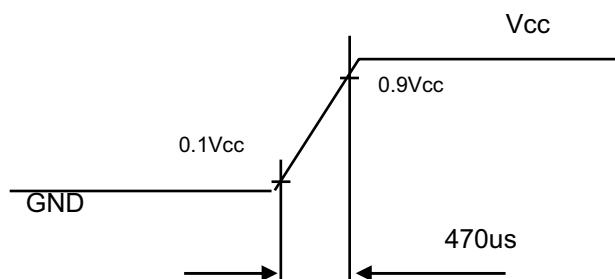

Note (3) The Specified Power consumption is under Vertical Stripe pattern.

Note (4) The specified power supply current is under the conditions at $V_{cc}=5.0V$, $T_a = 25 \pm 2^\circ C$, $f_v = 60\text{ Hz}$, whereas a power dissipation check pattern below is displayed.

a. White Pattern

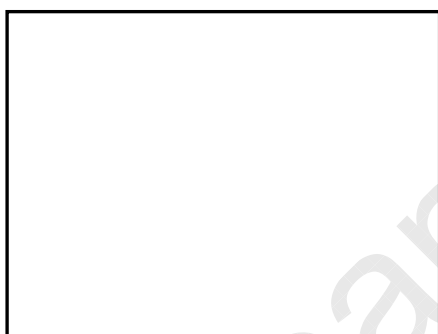

Active Area

b. Black Pattern



Active Area

c. Vertical Stripe Pattern

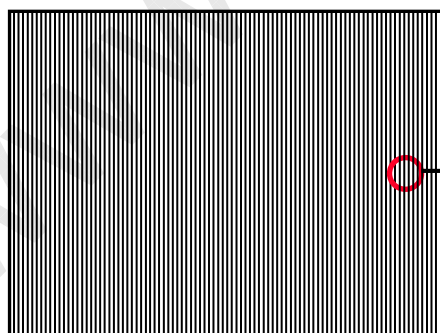

Active Area

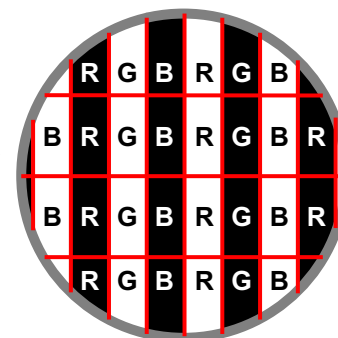

Note (5) The LVDS input characteristics are as follows :

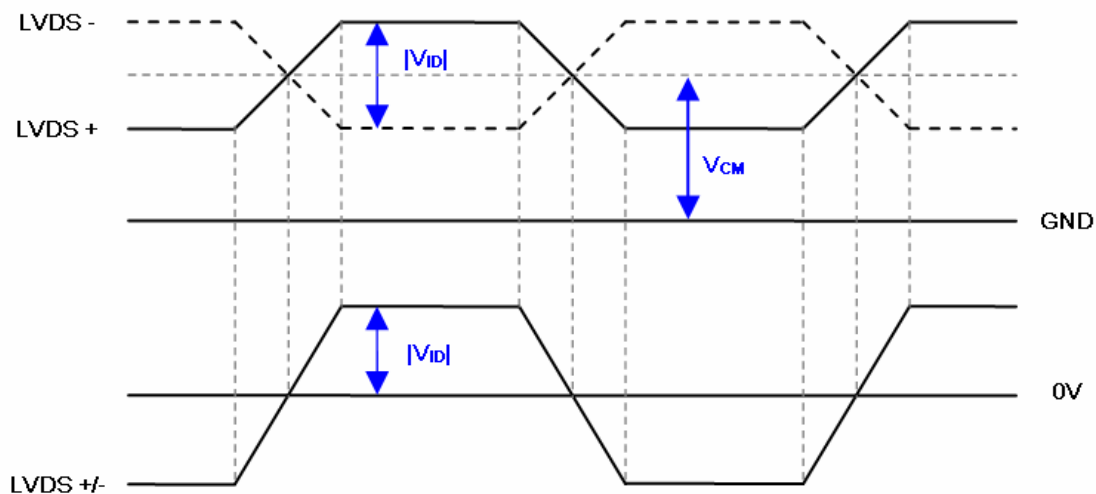

3.2 BACKLIGHT CONNECTOR PIN CONFIGURATION

3.2.1 LED LIGHT BAR CHARACTERISTICS

($T_a = 25 \pm 2^\circ\text{C}$)

Parameter	Symbol	Value			Unit	Note
		Min.	Typ.	Max.		
Light Bar Voltage	V_W	-	40.3	44.2	V	(1), Duty=100%, $I_L = 40\text{mA}$
Forward Voltage	V_f	-	3.1	3.4	V	$I_L = 40\text{mA}$
LED Current	I_L	---	40	50	mA	(1), (2) Duty=100%
Power consumption	P_{BL}	---	9.7	13.3	W	(1) Duty=100%, $I_L = 40\text{mA}$
Life time	-	30,000	-	-	Hrs	(3)

Note (1) LED light bar input voltage and current are measured by utilizing a true RMS multimeter as shown below:

Note (2) $P_{BL} = I_{PIN} \times V_{PIN} \times (6)$ input pins, LED light bar circuit is (13)Series, (6)Parallel.

Note (3) The lifetime of LED is defined as the time when LED packages continue to operate under the conditions at $T_a = 25 \pm 2^\circ\text{C}$ and $I = (20)\text{mA}$ (per chip) until the brightness becomes $\leq 50\%$ of its original value.

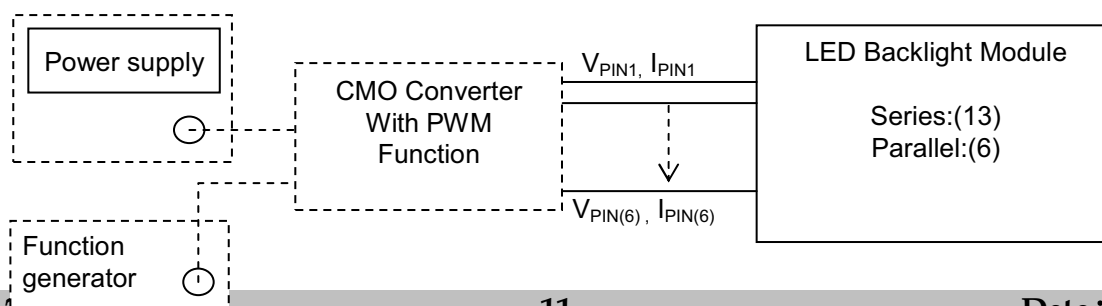

3.2.2 LIGHTBAR Connector Pin Assignment

The pin configuration for the housing and the leader wire is shown in the table below.

Connector: B-F,7083K-F12N-00L ,ENTERY(恩得利), or Compatible

Pin	Symbol	Feature
1	NC	No connect
2	LED1	LED1 negative polarity
3	LED2	LED2 negative polarity
4	LED3	LED3 negative polarity
5	NC	No connect
6	VLED (41.6V)	Input voltage Power Supply + (41.6V.typ)
7	VLED (41.6V)	Input voltage Power Supply + (41.6V.typ)
8	NC	No connect
9	LED4	LED4 negative polarity
10	LED5	LED5 negative polarity
11	LED6	LED6 negative polarity
12	NC	No connect

3.3 LVDS INPUT SIGNAL SPECIFICATIONS

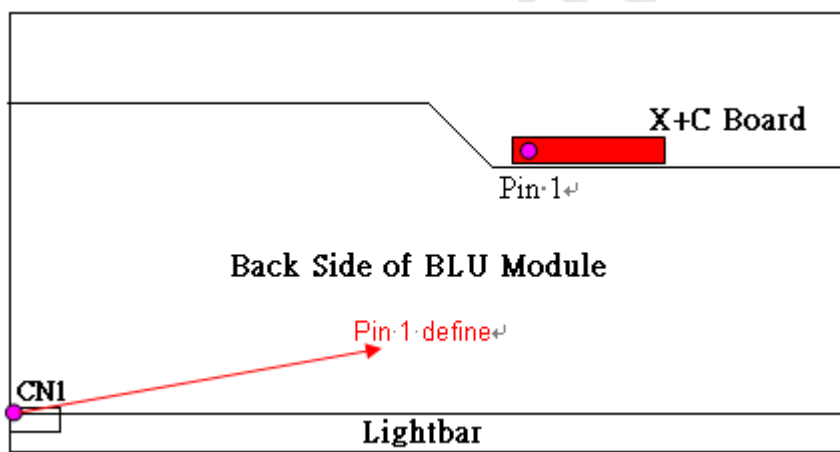

3.3.1 LVDS DATA MAPPING TABLE

LVDS Channel O0	LVDS output	D7	D6	D4	D3	D2	D1	D0
	Data order	OG0	OR5	OR4	OR3	OR2	OR1	OR0
LVDS Channel O1	LVDS output	D18	D15	D14	D13	D12	D9	D8
	Data order	OB1	OB0	OG5	OG4	OG3	OG2	OG1
LVDS Channel O2	LVDS output	D26	D25	D24	D22	D21	D20	D19
	Data order	DE	NA	NA	OB5	OB4	OB3	OB2
LVDS Channel O3	LVDS output	D23	D17	D16	D11	D10	D5	D27
	Data order	NA	OB7	OB6	OG7	OG6	OR7	OR6
LVDS Channel E0	LVDS output	D7	D6	D4	D3	D2	D1	D0
	Data order	EG0	ER5	ER4	ER3	ER2	ER1	ER0
LVDS Channel E1	LVDS output	D18	D15	D14	D13	D12	D9	D8
	Data order	EB1	EB0	EG5	EG4	EG3	EG2	EG1
LVDS Channel E2	LVDS output	D26	D25	D24	D22	D21	D20	D19
	Data order	DE	NA	NA	EB5	EB4	EB3	EB2
LVDS Channel E3	LVDS output	D23	D17	D16	D11	D10	D5	D27
	Data order	NA	EB7	EB6	EG7	EG6	ER7	ER6

4. BLOCK DIAGRAM OF INTERFACE

4.1 TFT LCD MODULE

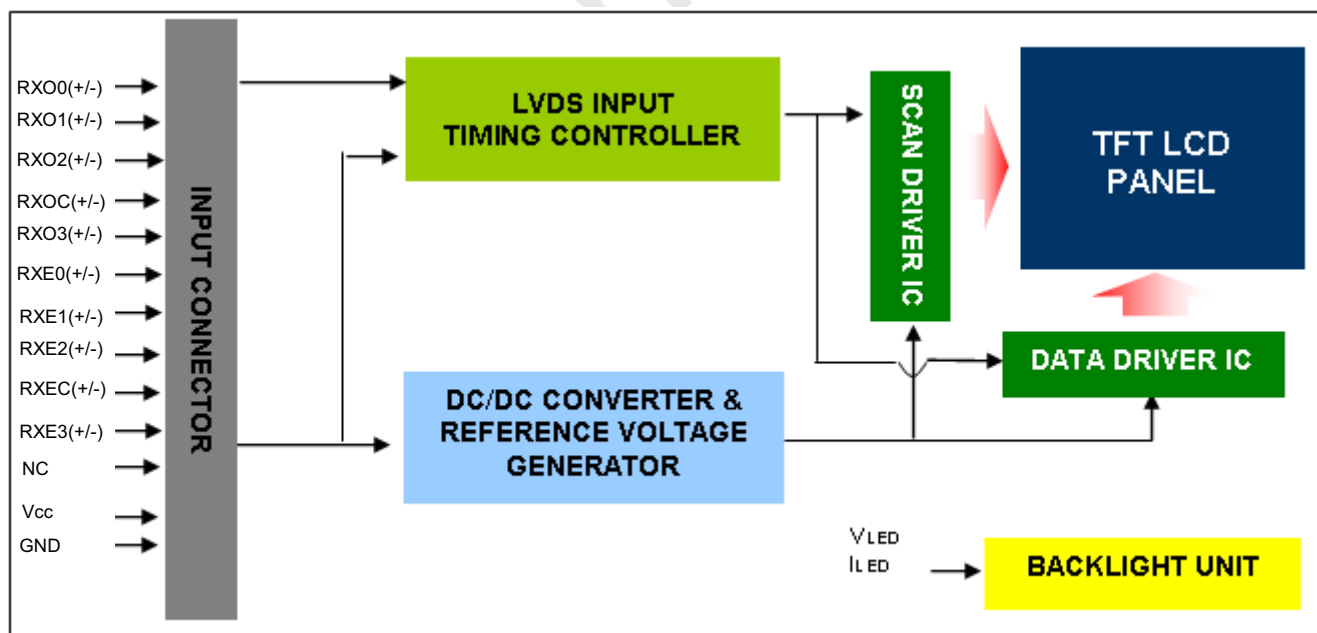

5. INPUT TERMINAL PIN ASSIGNMENT

5.1 TFT LCD Module Input

Pin	Name	Description
1	RXO0-	Negative LVDS differential data input. Channel O0 (odd)
2	RXO0+	Positive LVDS differential data input. Channel O0 (odd)
3	RXO1-	Negative LVDS differential data input. Channel O1 (odd)
4	RXO1+	Positive LVDS differential data input. Channel O1 (odd)
5	RXO2-	Negative LVDS differential data input. Channel O2 (odd)
6	RXO2+	Positive LVDS differential data input. Channel O2 (odd)
7	GND	Ground
8	RXOC-	Negative LVDS differential clock input. (odd)
9	RXOC+	Positive LVDS differential clock input. (odd)
10	RXO3-	Negative LVDS differential data input. Channel O3(odd)
11	RXO3+	Positive LVDS differential data input. Channel O3 (odd)
12	RXE0-	Negative LVDS differential data input. Channel E0 (even)
13	RXE0+	Positive LVDS differential data input. Channel E0 (even)
14	GND	Ground
15	RXE1-	Negative LVDS differential data input. Channel E1 (even)
16	RXE1+	Positive LVDS differential data input. Channel E1 (even)
17	GND	Ground
18	RXE2-	Negative LVDS differential data input. Channel E2 (even)
19	RXE2+	Positive LVDS differential data input. Channel E2 (even)
20	RXEC-	Negative LVDS differential clock input. (even)
21	RXEC+	Positive LVDS differential clock input. (even)
22	RXE3-	Negative LVDS differential data input. Channel E3 (even)
23	RXE3+	Positive LVDS differential data input. Channel E3 (even)
24	GND	Ground
25	NC	Not connection, this pin should be open.
26	NC	CMI internal test, this pin should connect to ground.
27	NC	Not connection, this pin should be open.
28	VCC	+5.0V power supply
29	VCC	+5.0V power supply
30	VCC	+5.0V power supply

Note (1) Connector Part No.: 093G30-B2001A-M4(STARCONN) or MSCKT2407P30H,STM(信盛)

Note (2) Mating Wire Cable Connector Part No.: FI-X30H(JAE) or FI-X30HL(JAE)

Note (3) Mating FFC Cable Connector Part No.: B-F,7083K-F12N-00L ,ENTERY(恩得利)

Note (4) The first pixel is odd.

Note (5) Input signal of even and odd clock should be the same timing.

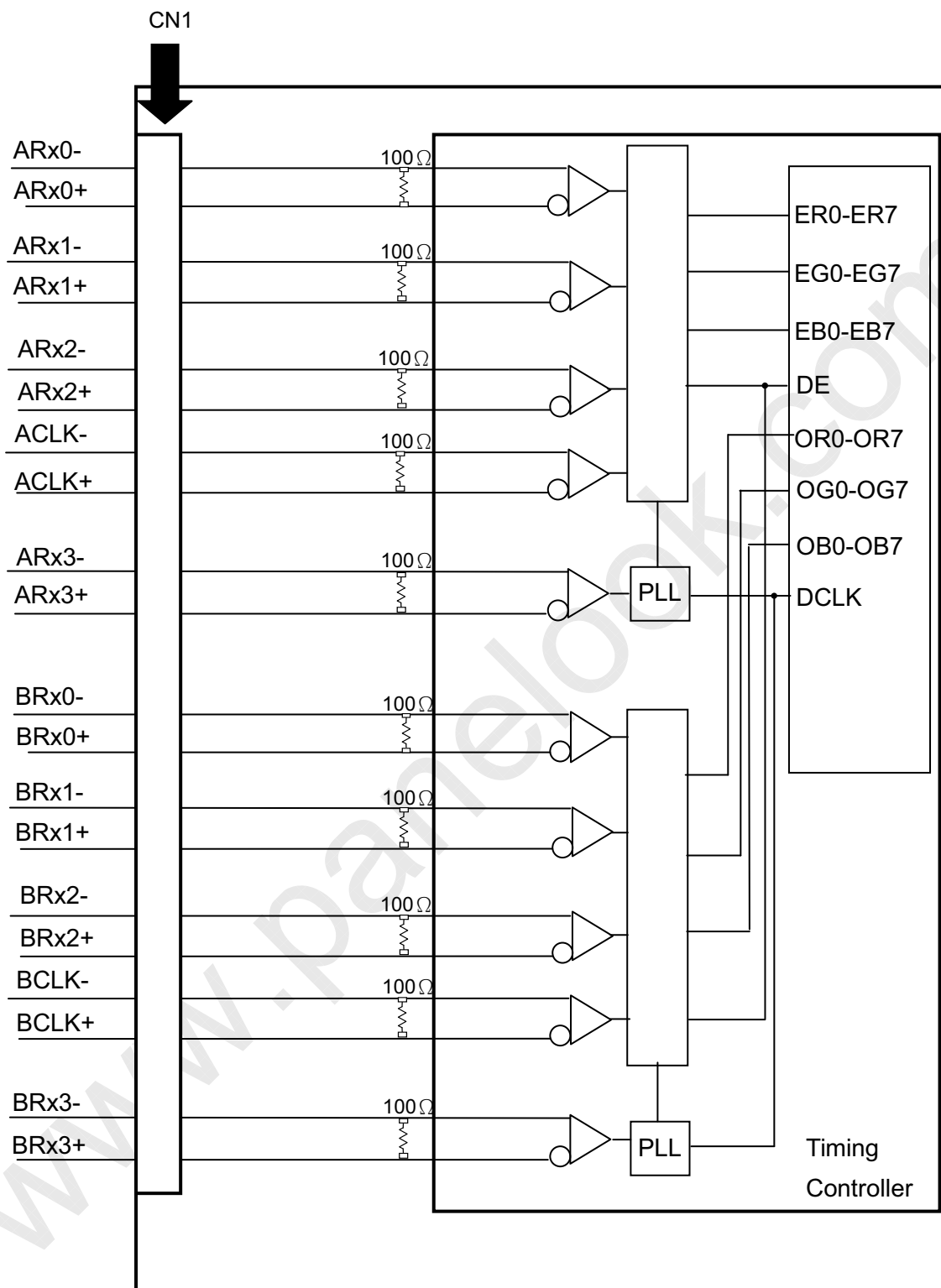
5.2 BLOCK DIAGRAM OF INTERFACE

ER0~ER7	Even pixel R data	OR0~OR7	Odd pixel R data
EG0~EG7	Even pixel G data	OG0~OG7	Odd pixel G data
EB0~EB7	Even pixel B data	OB0~OB7	Odd pixel B data
		DE	Data enable signal
		DCLK	Data clock signal

Note (1) The system must have the transmitter to drive the module.

Note (2) LVDS cable impedance shall be 50 ohms per signal line or about 100 ohms per twist-pair line when it is used differentially.

Note (3) Two pixel data send into the module for every clock cycle. The first pixel of the frame is odd pixel and the second pixel is even pixel.

5.3 LVDS INTERFACE

VESA Format : SELLVDS = L or Open

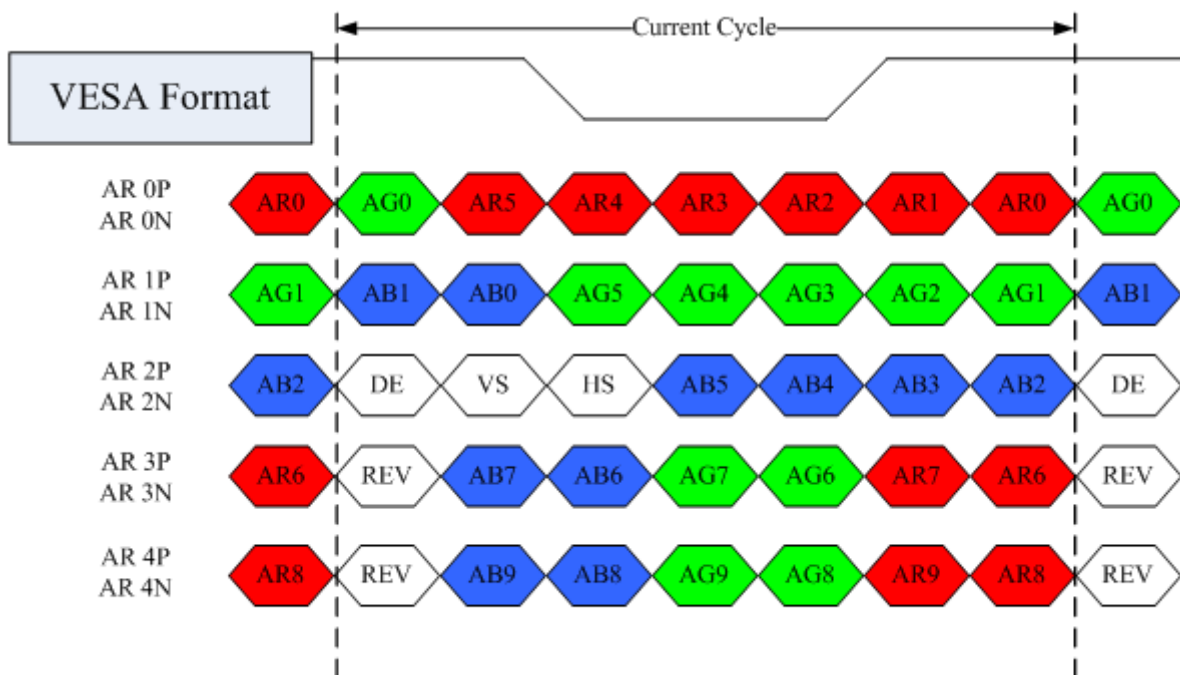

AR0~AR9 : First Pixel R Data (9; MSB, 0; LSB)

AG0~AG9 : First Pixel G Data (9; MSB, 0; LSB)

AB0~AB9 : First Pixel B Data (9; MSB, 0; LSB)

DE : Data enable signal

DCLK : Data clock signal

RSVD : Reserved

5.4 COLOR DATA INPUT ASSIGNMENT

The brightness of each primary color (red, green and blue) is based on the 8-bit gray scale data input for the color. The higher the binary input, the brighter the color. The table below provides the assignment of color versus data input.

Color		Data Signal																						
		Red								Green								Blue						
		R7	R6	R5	R4	R3	R2	R1	R0	G7	G6	G5	G4	G3	G2	G1	G0	B7	B6	B5	B4	B3	B2	B1
Basic Colors	Black	0	0	0	0	0	0	0	0	0	0	0	0	0	0	0	0	0	0	0	0	0	0	0
	Red	1	1	1	1	1	1	1	1	0	0	0	0	0	0	0	0	0	0	0	0	0	0	0
	Green	0	0	0	0	0	0	0	0	1	1	1	1	1	1	1	1	0	0	0	0	0	0	0
	Blue	0	0	0	0	0	0	0	0	0	0	0	0	0	0	0	0	1	1	1	1	1	1	1
	Cyan	0	0	0	0	0	0	0	0	1	1	1	1	1	1	1	1	1	1	1	1	1	1	1
	Magenta	1	1	1	1	1	1	1	1	0	0	0	0	0	0	0	0	1	1	1	1	1	1	1
	Yellow	1	1	1	1	1	1	1	1	1	1	1	1	1	1	1	1	0	0	0	0	0	0	0
	White	1	1	1	1	1	1	1	1	1	1	1	1	1	1	1	1	1	1	1	1	1	1	1
Gray Scale Of Red	Red(0) / Dark	0	0	0	0	0	0	0	0	0	0	0	0	0	0	0	0	0	0	0	0	0	0	
	Red(1)	0	0	0	0	0	0	1	0	0	0	0	0	0	0	0	0	0	0	0	0	0	0	
	Red(2)	0	0	0	0	0	0	1	0	0	0	0	0	0	0	0	0	0	0	0	0	0	0	
	:	:	:	:	:	:	:	:	:	:	:	:	:	:	:	:	:	:	:	:	:	:	:	
	:	:	:	:	:	:	:	:	:	:	:	:	:	:	:	:	:	:	:	:	:	:	:	
	Red(253)	1	1	1	1	1	1	0	1	0	0	0	0	0	0	0	0	0	0	0	0	0	0	
	Red(254)	1	1	1	1	1	1	1	0	0	0	0	0	0	0	0	0	0	0	0	0	0	0	
	Red(255)	1	1	1	1	1	1	1	1	0	0	0	0	0	0	0	0	0	0	0	0	0	0	
Gray Scale Of Green	Green(0) / Dark	0	0	0	0	0	0	0	0	0	0	0	0	0	0	0	0	0	0	0	0	0	0	
	Green(1)	0	0	0	0	0	0	0	0	0	0	0	0	0	0	1	0	0	0	0	0	0	0	
	Green(2)	:	:	:	:	:	:	:	:	:	:	:	:	:	:	:	:	:	:	:	:	:	:	
	:	:	:	:	:	:	:	:	:	:	:	:	:	:	:	:	:	:	:	:	:	:	:	
	:	0	0	0	0	0	0	0	1	1	1	1	1	1	0	1	0	0	0	0	0	0	0	
	Green(253)	0	0	0	0	0	0	0	1	1	1	1	1	1	1	0	0	0	0	0	0	0	0	
	Green(254)	0	0	0	0	0	0	0	1	1	1	1	1	1	1	1	0	0	0	0	0	0	0	
	Green(255)	0	0	0	0	0	0	0	1	1	1	1	1	1	1	1	1	0	0	0	0	0	0	
Gray Scale Of Blue	Blue(0) / Dark	0	0	0	0	0	0	0	0	0	0	0	0	0	0	0	0	0	0	0	0	0	0	
	Blue(1)	0	0	0	0	0	0	0	0	0	0	0	0	0	0	0	0	0	0	0	0	0	1	
	Blue(2)	0	0	0	0	0	0	0	0	0	0	0	0	0	0	0	0	0	0	0	0	0	1	
	:	:	:	:	:	:	:	:	:	:	:	:	:	:	:	:	:	:	:	:	:	:	:	
	:	:	:	:	:	:	:	:	:	:	:	:	:	:	:	:	:	:	:	:	:	:	:	
	Blue(253)	0	0	0	0	0	0	0	0	0	0	0	0	0	0	0	1	1	1	1	1	1	0	
	Blue(254)	0	0	0	0	0	0	0	0	0	0	0	0	0	0	0	1	1	1	1	1	1	0	
	Blue(255)	0	0	0	0	0	0	0	0	0	0	0	0	0	0	0	1	1	1	1	1	1	1	

Note (1) 0: Low Level Voltage, 1: High Level Voltage

6. INTERFACE TIMING

6.1 INPUT SIGNAL TIMING SPECIFICATIONS

The input signal timing specifications are shown as the following table and timing diagram. ($T_a = 25 \pm 2^\circ\text{C}$)

Signal	Item	Symbol	Min.	Typ.	Max.	Unit	Note
LVDS Receiver Clock	Frequency	$F_{\text{clk in}}$ ($=1/TC$)	58.54	74.25	97.98	MHz	—
	Input cycle to cycle jitter	$T_{\text{rc l}}$	—	—	200	ps	(2)
	Spread spectrum modulation range	$F_{\text{clk in}_m o d}$	$F_{\text{clk in}}-2\%$	—	$F_{\text{clk in}}+2\%$	MHz	(3)
	Spread spectrum modulation frequency	F_{SSM}	—	—	200	KHz	
LVDS Receiver Data	Setup Time	$T_{\text{lv su}}$	600	—	—	ps	—
	Hold Time	$T_{\text{lv hd}}$	600	—	—	ps	
Vertical Active Display Term	Frame Rate	F_r	50	60	75	Hz	—
	Total	T_v	1115	1125	1136	Th	$T_v=T_{vd}+T_{vb}$
	Display	T_{vd}	1080	1080	1080	Th	—
	Blank	T_{vb}	T_v-T_{vd}	45	T_v-T_{vd}	Th	—
Horizontal Active Display Term	Total	T_h	1050	1100	1150	T_c	$T_h=T_{hd}+T_{hb}$
	Display	T_{hd}	960	960	960	T_c	—
	Blank	T_{hb}	T_h-T_{hd}	140	T_h-T_{hd}	T_c	—

Note: Because this module is operated by DE only mode, Hsync and Vsync input signals are ignored.

INPUT SIGNAL TIMING DIAGRAM

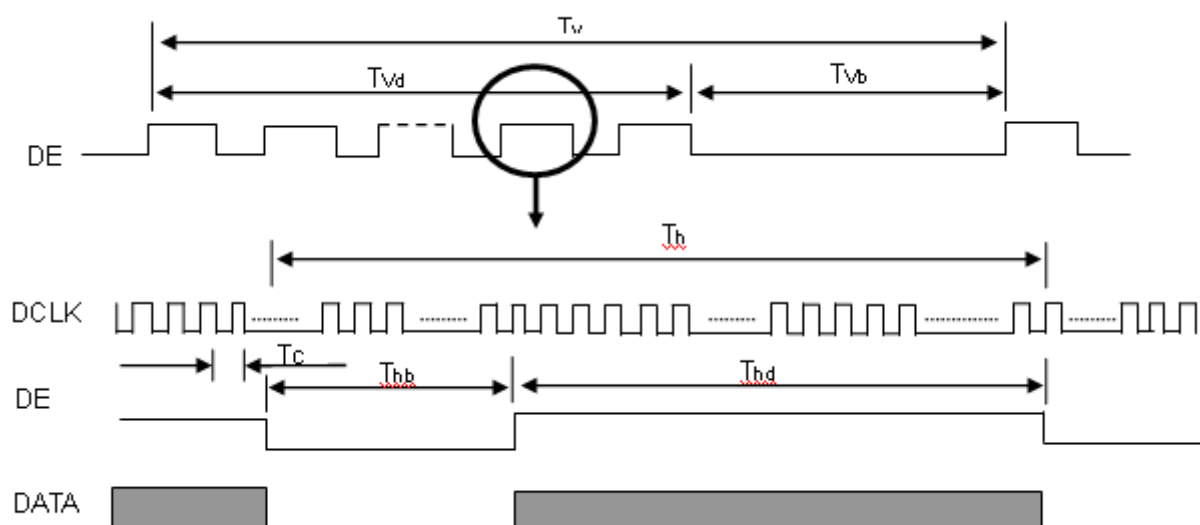

Note (1) Please make sure the range of frame rate has follow the below equation :

$$Fr(\max) \geq F_{clkin} / T_v \times T_h \leq Fr(\min)$$

Note (2) The input clock cycle-to-cycle jitter is defined as below figures. $Trcl = |T_1 - T_2|$

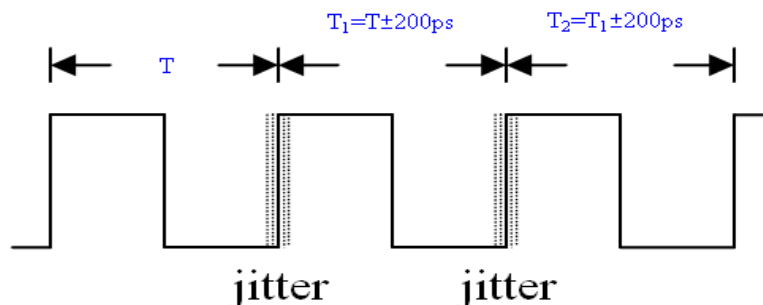

Note (3) The SSCG (Spread spectrum clock generator) is defined as below figures.

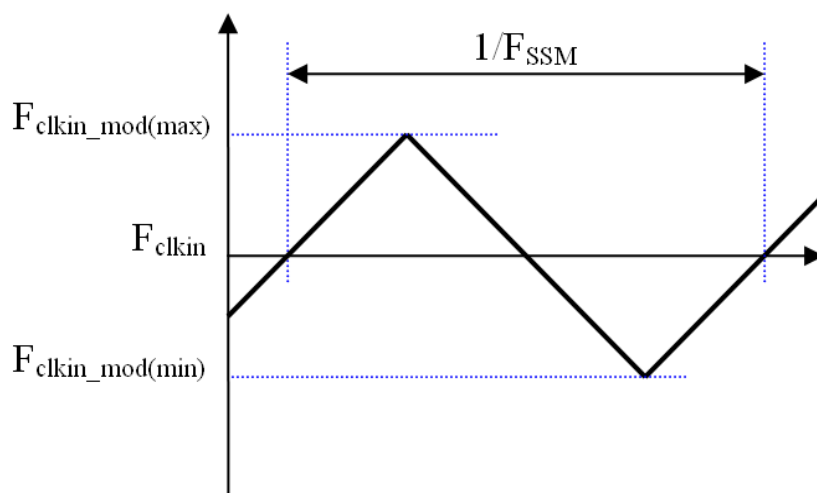

6.2 POWER ON/OFF SEQUENCE

To prevent a latch-up or DC operation of LCD module, the power on/off sequence should be as the diagram below.

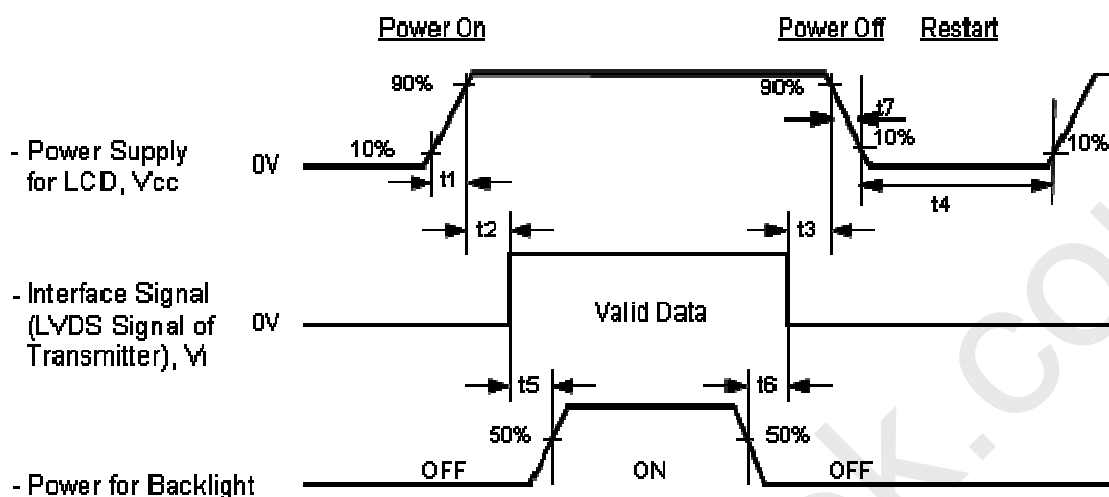

Timing Specifications:

0.5	<	t1	≤	10	msec
0	<	t2	≤	50	msec
0	<	t3	≤	50	msec
		t4	≥	500	msec
		t5	≥	450	msec
		t6	≥	90	msec
5	≤	t7	≤	100	msec

Note.

- (1) The supply voltage of the external system for the module input should be the same as the definition of Vcc.
- (2) When the backlight turns on before the LCD operation of the LCD turns off, the display may momentarily become abnormal screen.
- (3) In case of Vcc = off level, please keep the level of input signals on the low or keep a high impedance.
- (4) t4 should be measured after the module has been fully discharged between power off and on period.
- (5) Interface signal shall not be kept at high impedance when the power is on.
- (6) CMO won't take any responsibility for the products which are damaged by the customers not following the Power Sequence.
- (7) There might be slight electronic noise when LCD is turned off (even backlight unit is also off). To avoid this symptom, we suggest "Vcc falling timing" to follow "t7 spec".

www.panelook.com

7. OPTICAL CHARACTERISTICS

7.1 TEST CONDITIONS

Item	Symbol	Value	Unit
Ambient Temperature	Ta	25±2	oC
Ambient Humidity	Ha	50±10	%RH
Supply Voltage	VCC	5	V
Input Signal	According to typical value in "3. ELECTRICAL CHARACTERISTICS"		
LED Current	IL	40 ± 0.6	mA

The LCD module should be stabilized at given temperature for 1 hour to avoid abrupt temperature change during measuring. In order to stabilize the luminance, the measurement should be executed after lighting backlight for 1 hour in a windless room.

7.2 OPTICAL SPECIFICATIONS

The relative measurement methods of optical characteristics are shown in 7.2. The following items should be measured under the test conditions described in 7.1 and stable environment shown in 7.1.

Item	Symbol	Condition	Min.	Typ.	Max.	Unit	Note					
Contrast Ratio	CR		700	1000	—	—	Note (2)					
Response Time	T_R		—	1.3	2.2	ms	Note (3)					
	T_F		—	3.7	5.8							
Center Luminance of White	LC		200	250	—	cd/m ₂	Note (5)					
White Variation	δW		—	—	1.3	—	Note (7)					
Cross Talk	CT		—	—	4	%	Note (6)					
Color Chromaticity	Red	R_x	$\theta_x=0^\circ, \theta_y=0^\circ$ Viewing angle at normal direction	Typ. -0.03	Typ. +0.03	—	(1)(4)					
		R_y										
	Green	G_x										
		G_y										
	Blue	B_x										
		B_y										
	White	W_x										
		W_y										
	Color Gamut	C.G						—	70	—	%	NTSC
	Viewing Angle	Horizontal						$\theta_{x+} + \theta_{x-}$	$CR \geq 10$ USB2000	150	170	—
Vertical		$\theta_{y+} + \theta_{y-}$	140	160	—							
Horizontal		$\theta_{x+} + \theta_{x-}$	$CR \geq 5$ USB2000	160	178	—						
Vertical		$\theta_{y+} + \theta_{y-}$		150	170	—						

Note (1) Definition of Viewing Angle (θ_x , θ_y):

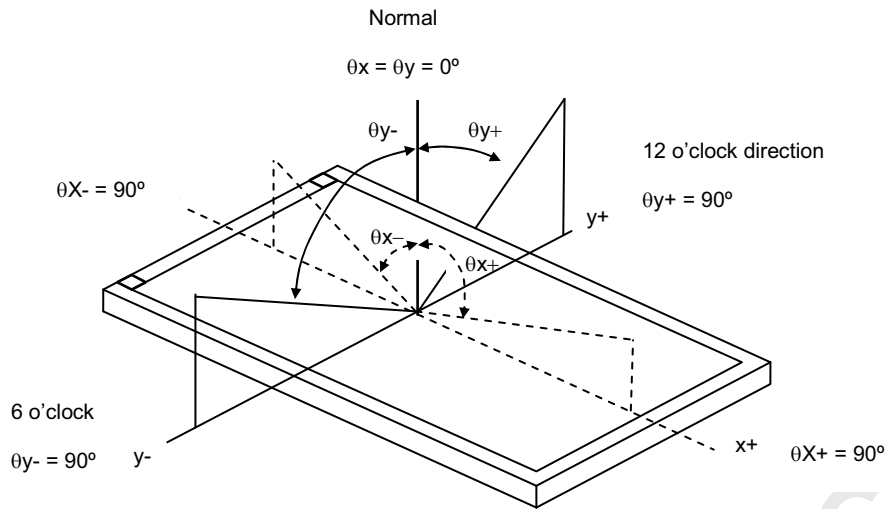

Note (2) Definition of Contrast Ratio (CR):

The contrast ratio can be calculated by the following expression.

$$\text{Contrast Ratio (CR)} = \frac{\text{Surface Luminance with all white pixels}}{\text{Surface Luminance with all black pixels}}$$

CR = CR (X), where CR (X) is corresponding to the Contrast Ratio of the point X at the figure in Note(6).

Note (3) Definition of Response Time (T_R , T_F):

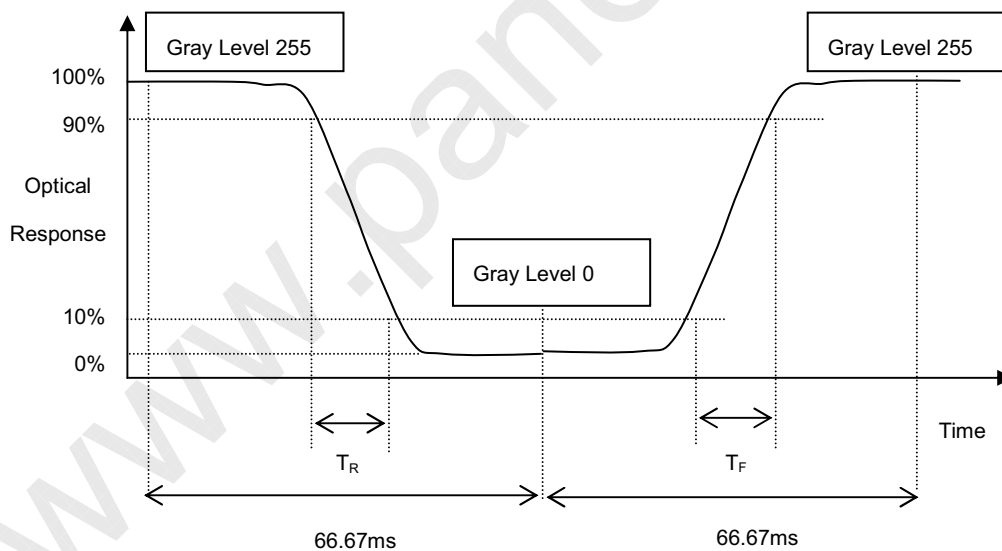

Note (4) Measurement Setup:

The LCD module should be stabilized at given temperature for 1 hour to avoid abrupt temperature change during measuring. In order to stabilize the luminance, the measurement should be executed after lighting backlight for 1 hour in a windless room.

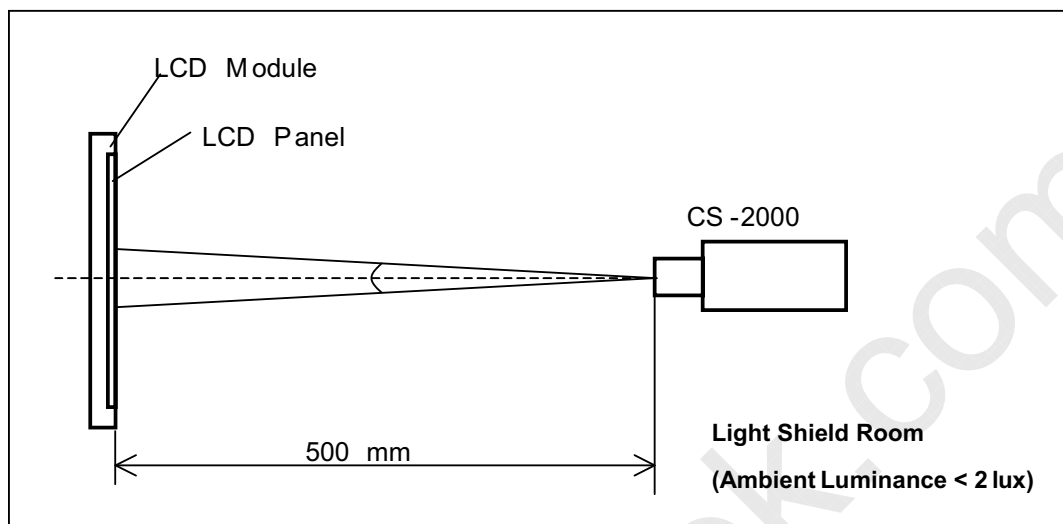
Note (5) Definition of Luminance of White (L_C , L_{AVE}):

Measure the luminance of gray level 255 at center point and 5 points

$L_C = L(5)$, where $L(X)$ is corresponding to the luminance of the point X at the figure in Note (6).

Note (6) Definition of Cross Talk (CT):

$$CT = | Y_B - Y_A | / Y_A \times 100 (\%)$$

Where:

Y_A = Luminance of measured location without gray level 0 pattern (cd/m²)

Y_B = Luminance of measured location with gray level 0 pattern (cd/m²)

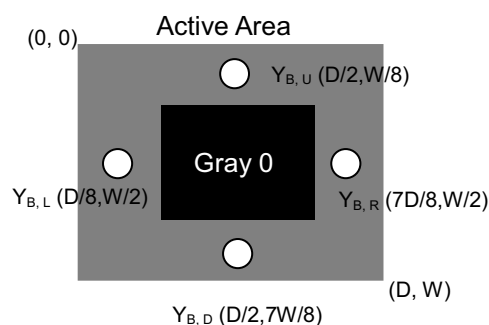
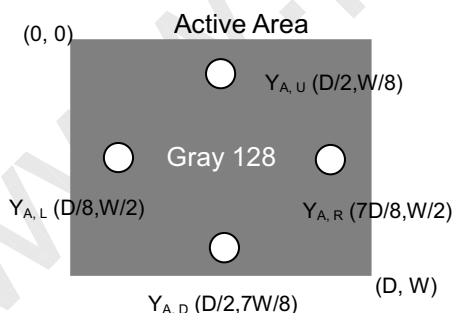
Note (7) Definition of White Variation (δW):

Measure the luminance of gray level 255 at 5 points

$$\delta W = \text{Maximum} [L(1), L(2), L(3), L(4), L(5)] / \text{Minimum} [L(1), L(2), L(3), L(4), L(5)]$$

8. PRECAUTIONS

8.1 ASSEMBLY AND HANDLING PRECAUTIONS

- [1] Do not apply rough force such as bending or twisting to the module during assembly.
- [2] It is recommended to assemble or to install a module into the user's system in clean working areas. The dust and oil may cause electrical short or worsen the polarizer.
- [3] Do not apply pressure or impulse to the module to prevent the damage of LCD panel and Backlight.
- [4] Always follow the correct power-on sequence when the LCD module is turned on. This can prevent the damage and latch-up of the CMIS LSI chips.
- [5] Bezel of Set can not press or touch the panel surface. It will make light leakage or scrape.
- [6] Do not plug in or pull out the I/F connector while the module is in operation.
- [7] Do not disassemble the module.
- [8] Use a soft dry cloth without chemicals for cleaning, because the surface of polarizer is very soft and easily scratched.
- [9] Moisture can easily penetrate into LCD module and may cause the damage during operation.
- [10] When storing modules as spares for a long time, the following precaution is necessary.
 - [10.1] Do not leave the module in high temperature, and high humidity for a long time. It is highly recommended to store the module with temperature from 0 to 35°C at normal humidity without condensation.
 - [10.2] The module shall be stored in dark place. Do not store the TFT-LCD module in direct sunlight or fluorescent light.
- [11] When ambient temperature is lower than 10°C, the display quality might be reduced. For example, the response time will become slow, and the starting voltage of CCFL will be higher than that of room temperature.

8.2 SAFETY PRECAUTIONS

- [1] The startup voltage of a Backlight is approximately 1000 Volts. It may cause an electrical shock while assembling with the inverter. Do not disassemble the module or insert anything into the Backlight unit.
- [2] If the liquid crystal material leaks from the panel, it should be kept away from the eyes or mouth. In case of contact with hands, skin or clothes, it has to be washed away thoroughly with soap.
- [3] After the module's end of life, it is not harmful in case of normal operation and storage.

9. DEFINITION OF LABELS

9.1 CMI MODULE LABEL

The barcode nameplate is pasted on each module as illustration, and its definitions are as following explanation.

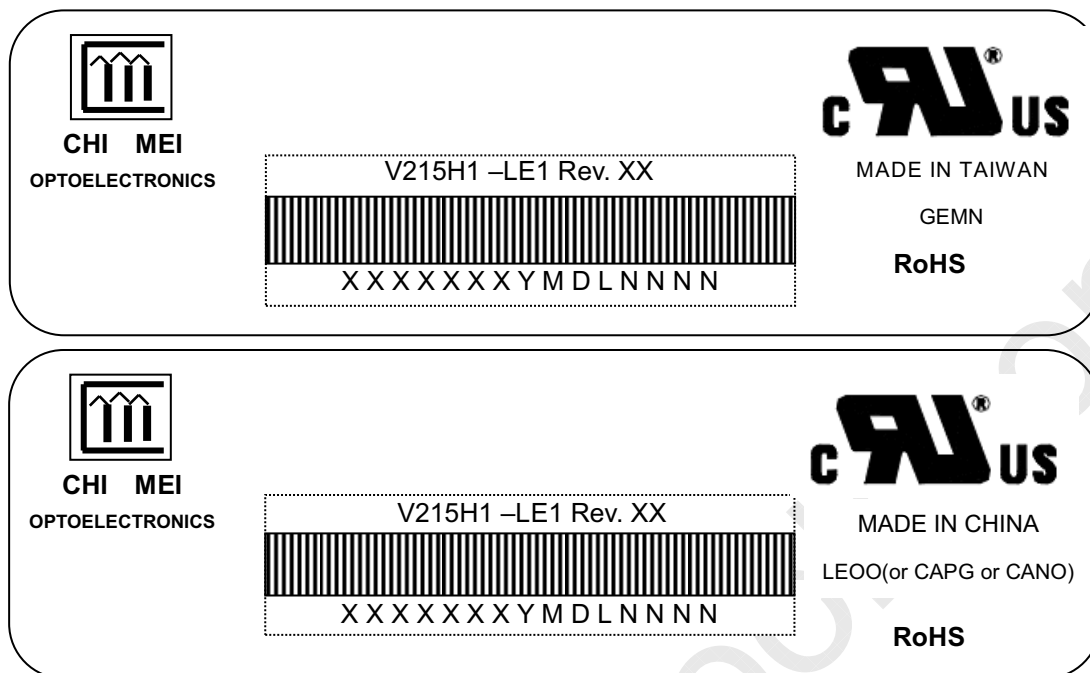

Model Name: V215H1 -LE1

Revision: Rev. XX, for example: A0, A1... B1, B2... or C1, C2...etc.

Serial ID: X X X X X X X Y M D L N N N N

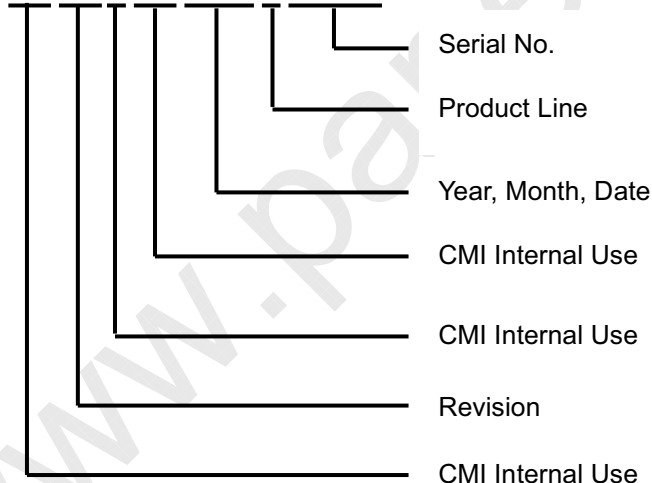

Serial ID includes the information as below:

Manufactured Date:

Year : 2001=1, 2002=2, 2003=3, 2004=4...2010=0, 2011=1, 2012=2...

Month: 1~9, A~C, for Jan. ~ Dec.

Day: 1~9, A~Y, for 1st to 31st, exclude I, O, and U.

Revision Code : Cover all the change

Serial No. : Manufacturing sequence of product

Product Line : 1 → Line1, 2 → Line 2, ...etc.

10. PACKAGING

10.1 PACKAGING SPECIFICATIONS

- (1) 13 LCD modules / 1 Box
- (2) Box dimensions: 567(L) X 301(W) X 376(H) mm
- (3) Weight: 27.525kg (13 modules per box)

10.2 PACKAGING METHOD

Figures 10-1 and 10-2 are the packing method.

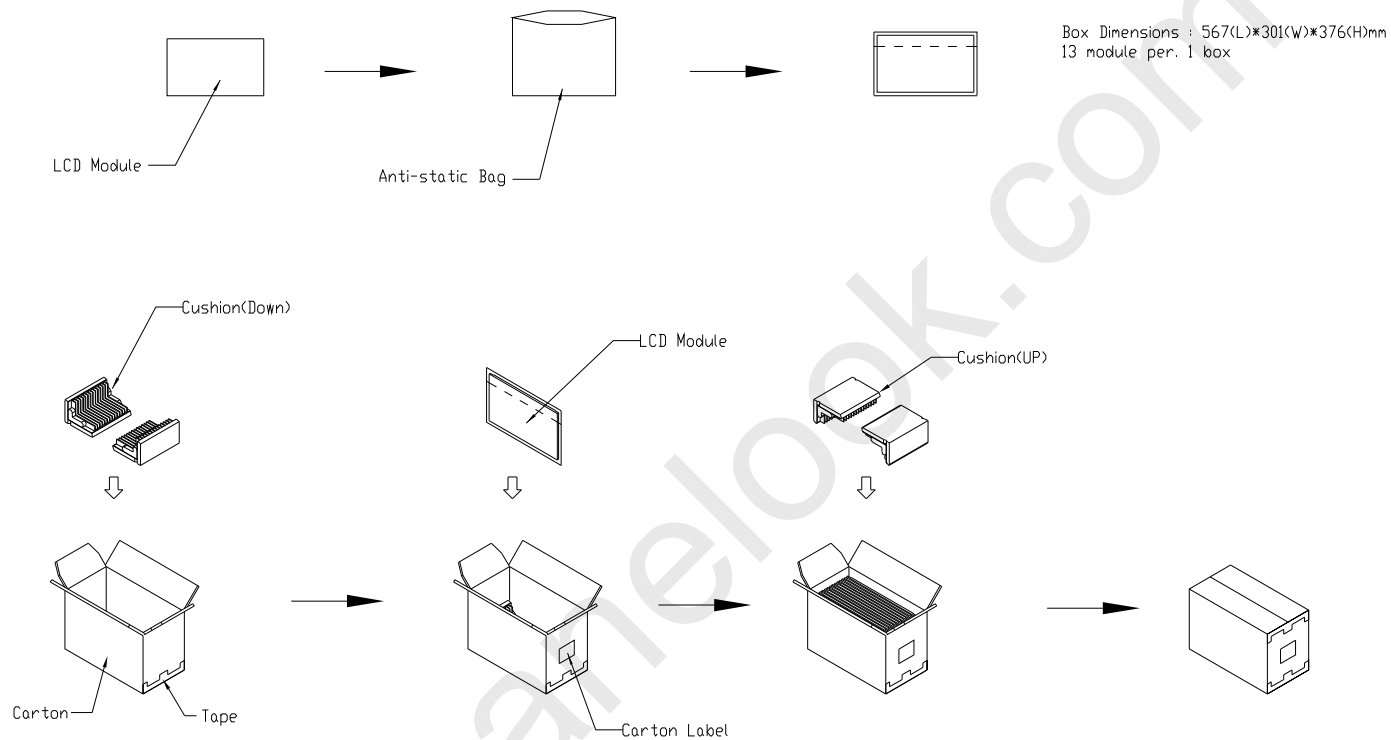

Figure 10-1 packing method

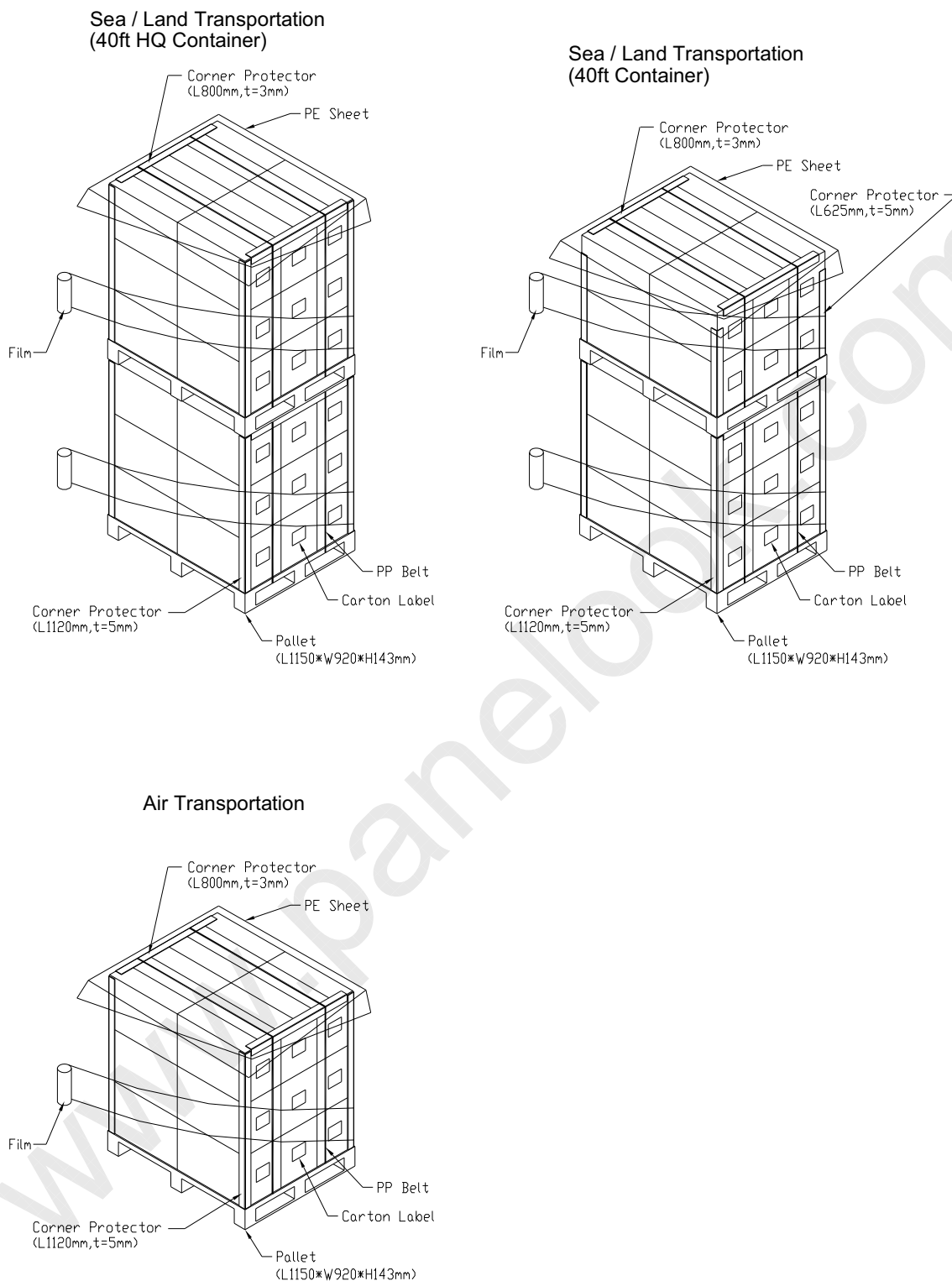
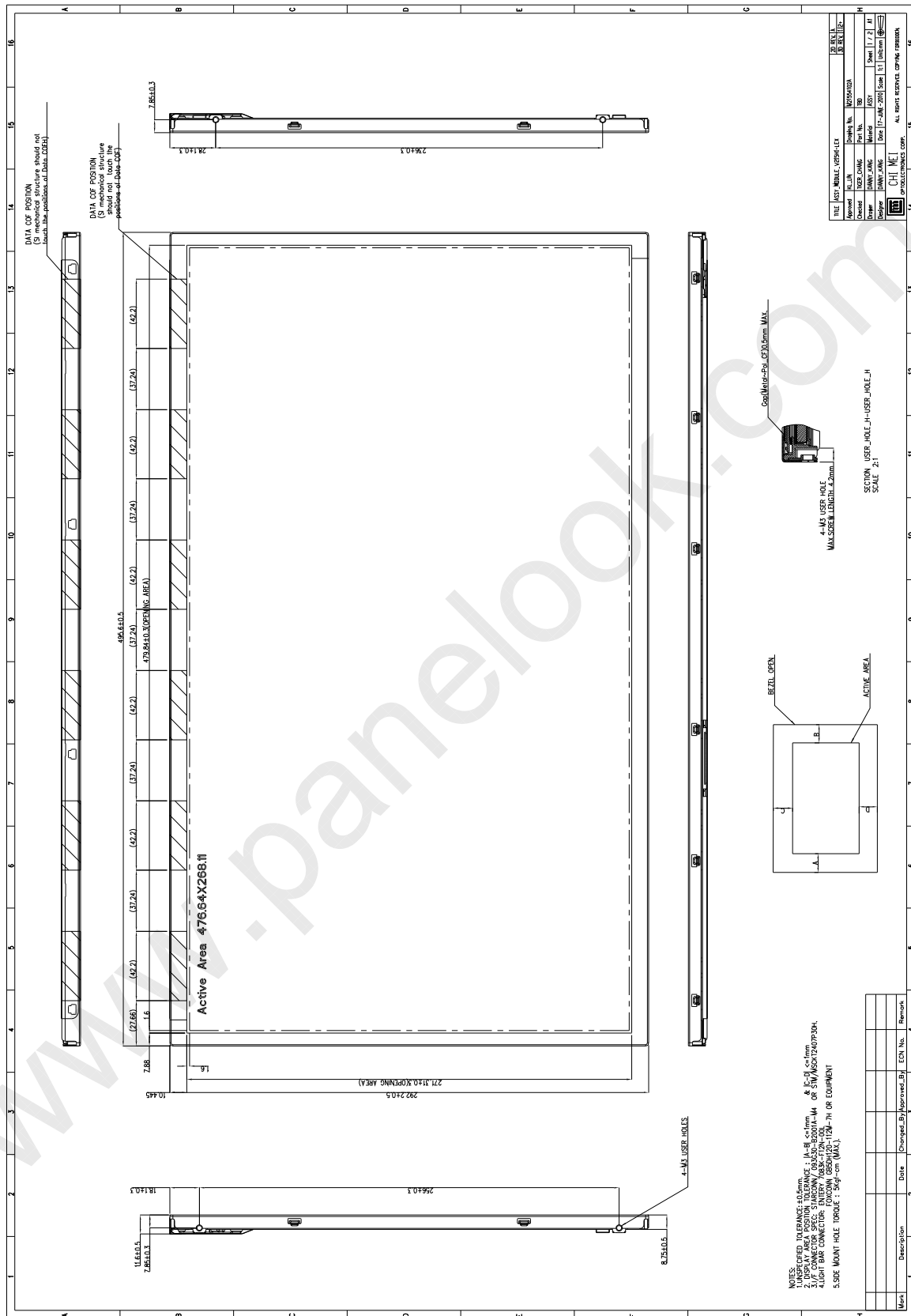

Figure 10-2 packing method

11. MECHANICAL CHARACTERISTIC



PRODUCT SPECIFICATION

