

TFT LCD Preliminary Specification

MODEL NO.:V216B1-DE01

(Rev: A2.0)

Customer: _____
Approved by: _____
Note:

Approved By	ASSEMBLY LCD TV LCM Division	

Checked By	R&D Dept.	QA Dept.

Reviewed By	TV LCM Marketing and Sale Dept.	

- CONTENTS -

REVISION HISTORY	-----	3
1. GENERAL DESCRIPTION	-----	4
1.1 OVERVIEW		
1.2 FEATURES		
1.3 GENERAL SPECIFICATIONS		
1.4 MECHANICAL SPECIFICATIONS		
2. ABSOLUTE MAXIMUM RATINGS	-----	5
2.1 ABSOLUTE RATINGS OF ENVIRONMENT		
2.2 PACKAGE STORAGE		
2.3 ELECTRICAL ABSOLUTE RATINGS		
2.3.1 TFT LCD MODULE		
3. ELECTRICAL CHARACTERISTICS	-----	7
3.1 TFT LCD MODULE		
3.2 BACKLIGHT UNIT		
3.2.1 LED UNIT CHARACTERISTICS		
3.2.2 LED CHARACTERISTICS		
4. BLOCK DIAGRAM	-----	11
4.1 TFT LCD MODULE		
5. PIN CONNECTION	-----	12
5.1 TFT LCD MODULE		
5.2 LVDS DATA MAPPING TABLE		
5.3 BACKLIGHT UNIT		
5.4 COLOR DATA INPUT ASSIGNMENT		
6. INTERFACE TIMING	-----	16
6.1 INPUT SIGNAL TIMING SPECIFICATIONS		
6.2 POWER ON/OFF SEQUENCE		
7. OPTICAL CHARACTERISTICS	-----	19
7.1 TEST CONDITIONS		
7.2 OPTICAL SPECIFICATIONS		
8. DEFINITION OF LABELS	-----	23
8.1 ASSEMBLY LCD MODULE LABEL		
9. PACKAGING	-----	24
9.1 PACKING SPECIFICATIONS		
9.2 PACKING METHOD		
10. PRECAUTIONS	-----	26
10.1 ASSEMBLY AND HANDLING PRECAUTIONS		
10.2 SAFETY PRECAUTIONS		
10.3 STORAGE PRECAUTIONS		
11. MECHANICAL CHARACTERISTICS	-----	27

REVISION HISTORY

Version	Date	Page (New)	Section	Description
Ver 2.0	18,JUN '10	All	All	Preliminary Specification was first issued.

1. GENERAL DESCRIPTION

1.1 OVERVIEW

V216B1-DE01 is a 21.6" TFT Liquid Crystal Display module with LED Backlight unit and 1ch-LVDS interface. This module supports 1366 x 768 WXGA format and can display 16.7M colors (6-bit+HI-FRC colors). The LED driver module for backlight is not built-in.

1.2 FEATURES

- High Brightness 250 nits
- Ultra-high contrast ratio 800:1
- Faster Response Time (Gray to Gray Average 6.5ms)
- High Color Saturation NTSC 72%
- DE (Data Enable) Only Mode
- LVDS (Low Voltage Differential Signaling) Interface
- Color Reproduction (Nature Color)

1.3 GENERAL

Item	Specification	Unit	Note
Active Area	477.42 (H) x 268.42(V) (21.6" diagonal)	mm	(1)
Bezel Opening Area	481.5 (H) x 272.5 (V)	mm	
Driver Element	a-si TFT active matrix	-	
Pixel Number	1366 x R.G.B. x 768	pixel	
Pixel Pitch (Sub Pixel)	0.1165(H) x 0.3495 (V)	mm	
Pixel Arrangement	RGB vertical stripe	-	
Display Colors	16.7M	color	
Display Operation Mode	TN / Normally White	-	
Surface Treatment	Anti-Glare coating (Haze 25%),Hard coating (3H)	-	

1.4 MECHANICAL SPECIFICATIONS

Item		Min	Typ	Max	Unit
Module Size	Horizontal(H)	-	501	-	mm
	Vertical(V)		297		mm
	Depth(D)rear		10.7		mm
	Depth(D)Max		13.9		mm
Weight		-	2320	-	g

2. ABSOLUTE MAXIMUM RATINGS

2.1 ABSOLUTE RATINGS OF ENVIRONMENT

Item	Symbol	Value		Unit	Note
		Min.	Max.		
Storage Temperature	T _{ST}	-20	+60	°C	(1)
Operating Ambient Temperature	T _{OP}	0	+50	°C	(1), (2)
Shock(Non-Operating)	S _{NOF}	-	50	G	(3),(5)
Altitude Storage	V _{NOF}	-	1.0	G	(4),(5)

Note (1) Temperature and relative humidity range is shown in the figure below.

- (a) 90 %RH Max. ($T_a \leq 40$ °C).
- (b) Wet-bulb temperature should be 39 °C Max. ($T_a > 40$ °C).
- (c) No condensation.

Note (2) The maximum operating temperature is based on the test condition that the surface temperature of display area is less than or equal to 65 °C with LCD module alone in a temperature controlled chamber. Thermal management should be considered in your product design to prevent the surface temperature of display area from being over 65 °C. The range of operating temperature may degrade in case of improper thermal management in your product design.

Note (3) 11ms, half-sine wave, 1 time for $\pm X$, $\pm Y$, $\pm Z$.

Note (4) 10~200Hz, 10 min, 1time each X,Y,Z.

Note (5) At testing Vibration and Shock, the fixture in holding the module has to be hard and rigid enough so that the module would not be twisted or bent by the fixture.

Relative Humidity (%RH)

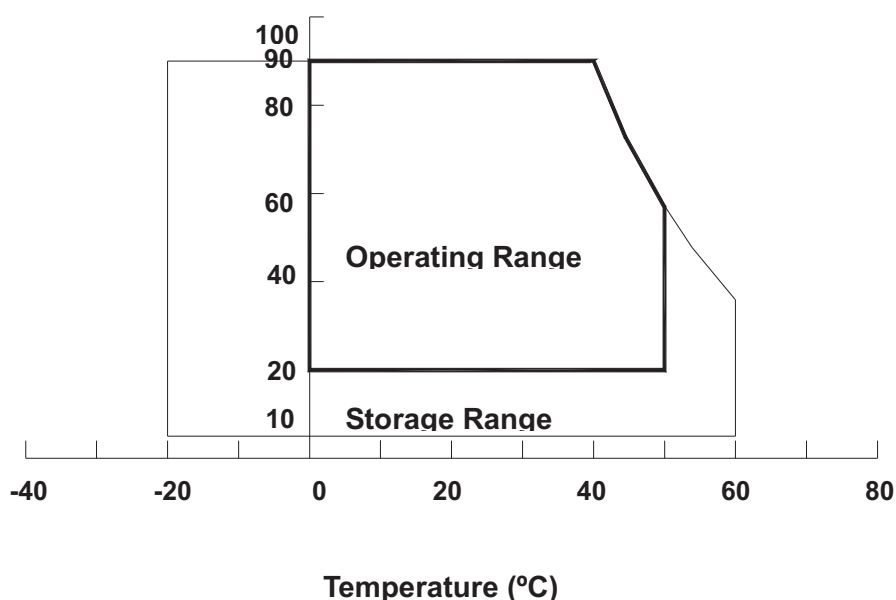

2.2 PACKAGE STORAGE

When storing modules as spares for a long time, the following precaution is necessary.

- (a) Do not leave the module in high temperature, and high humidity for a long time. It is highly recommended to store the module with temperature from 0 to 35 °C at normal humidity without condensation.
- (b) The module shall be stored in dark place. Do not store the TFT-LCD module in direct sunlight or Fluorescent light.

2.3 ELECTRICAL ABSOLUTE RATINGS

2.3.1 TFT LCD MODULE

Item	Symbol	Value		Unit	Note
		Min	Max		
Power Supply Voltage	Vcc	4.5	5.5	V	
Logic Input Voltage	Vin	-0.3	3.6	V	

3. ELECTRICAL CHARACTERISTICS

3.1 TFT LCD MODULE

Ta = 25±2°C

Parameter	Symbol	Value			Unit	Note	
		Min.	Typ.	Max.			
Power Supply Voltage	V _{CC}	4.5	5.0	5.5	V	(1)	
Power Supply Ripple Voltage	V _{RP}	-	-	150	mV		
Rush Current	I _{RUSH}	-	-	3.0	A	(2)	
Power Supply Current	White	-	0.5	-	A	(3)	
	Black	-	0.85	0.95	A		
	Vertical Stripe	-	0.75	-	A		
LVDS Interface	Differential Input High Threshold Voltage	V _{LVTH}	+100	-	mV		
	Differential Input Low Threshold Voltage	V _{LVTL}	-	-100	mV		
	Common Input Voltage	V _{LVC}	1.125	1.25	1.375	V	
	Terminating Resistor	R _T	-	100	-	ohm	
CMOS interface	Input High Threshold Voltage	V _{IH}	2.7	-	3.3	V	
	Input Low Threshold Voltage	V _{IL}	0	-	0.7	V	

Note (1) The module should be always operated within above ranges.

Note (2) Measurement Conditions:

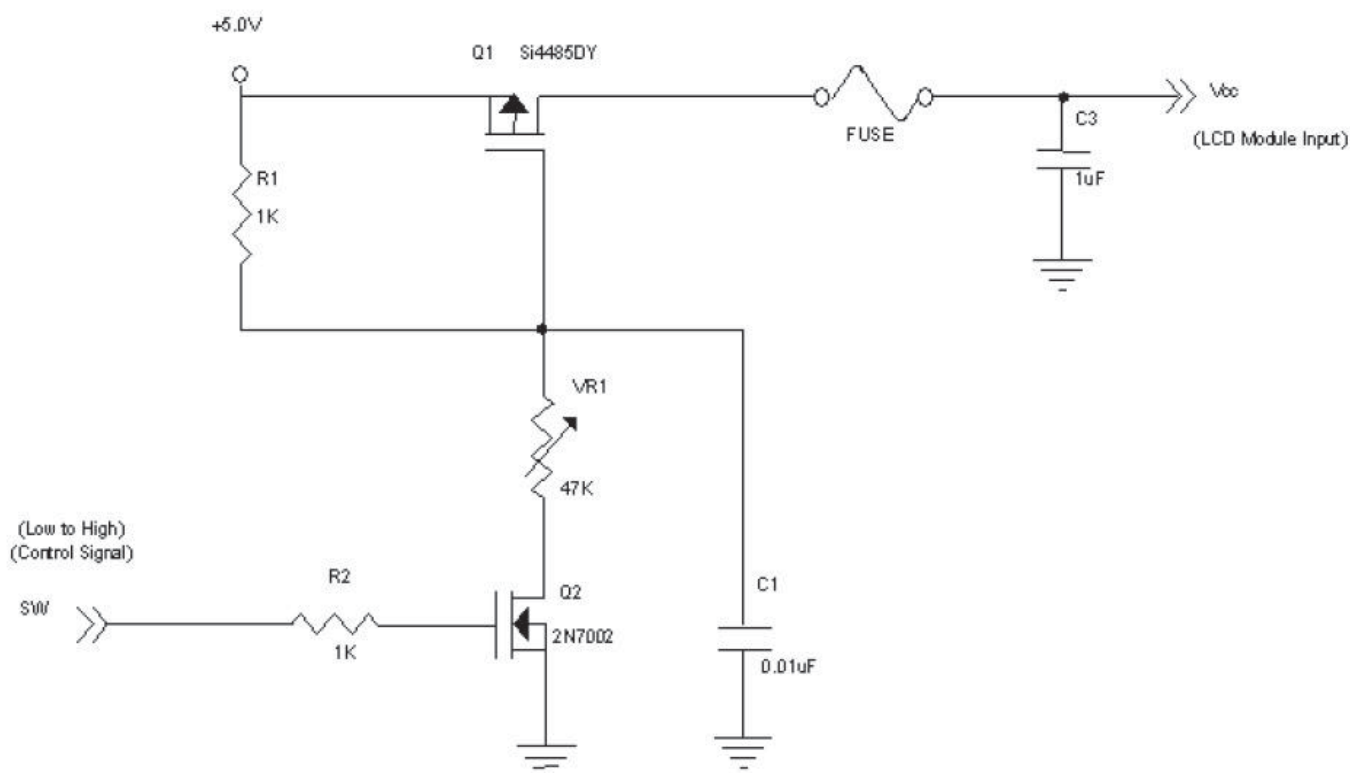

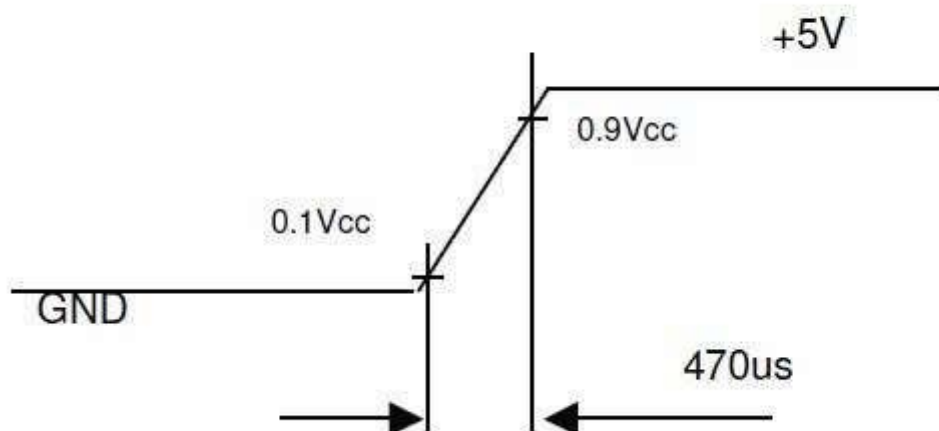
Vcc rising time is 470us

Note (3) The specified power supply current is under the conditions at $V_{cc}=5V$, $T_a=25\pm 2$ °C, $f_v=60\text{HZ}$, whereas a power dissipation check pattern below is displayed.

a. White Pattern



Active Area

b. Black Pattern



Active Area

c. Vertical Stripe Pattern

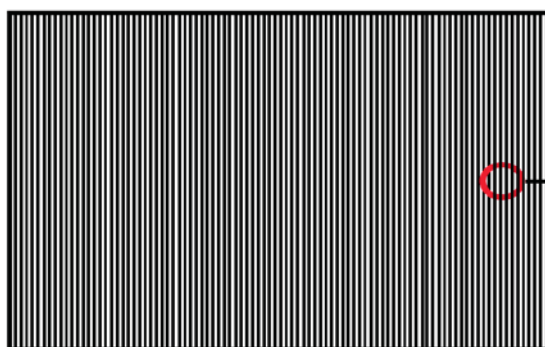

Active Area

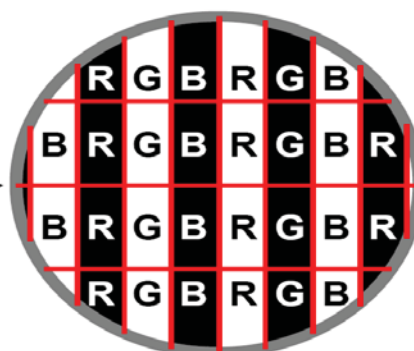

3.2 BACKLIGHT UNIT

3.2.1 LED UNIT CHARACTERISTICS ($T_a = 25 \pm 2 \text{ }^\circ\text{C}$)

Parameter	Symbol	Value			Unit	Note
		Min	Typ	Max		
LED Light Bar Input Voltage	V_o	14.5	16	18	V_{DC}	(1),(Duty 100%)
Power Consumption	P_{O1}	-	10.4	-	W	
LED Life Time	L_{LED}	100000	-	-	H	(2)
LED Light Bar Input Current	I_o	-	650	-	mA_{DC}	(1),(Duty 100%)

NOTE(1): LED light Bar consists of one channels 10-GROUPS parallel LEDs, each of which is 5-serial LEDs.

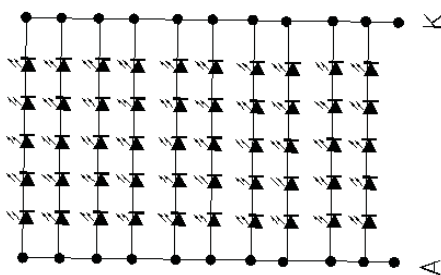

LED current is measure by utilizing a high frequency current meter as shown below:

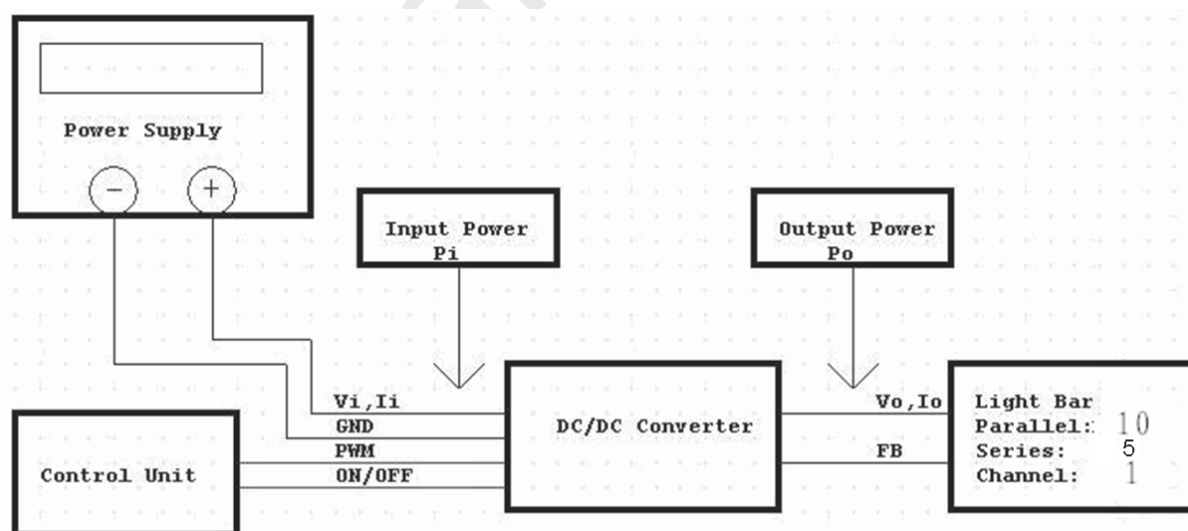

NOTE(2): The lifetime of LED is defined as the time when it continues to operate under the condition at $T_a=25\pm 2^\circ\text{C}$ and $I=65\text{mA}$ (Per EA) until the brightness $\leq 50\%$ of its original value

3.2.2 LED CHARACTERISTICS

- a. LED Model:NAW-FSM-Y7Y8-CS0359
- b.Operating Current: 65mA.
- c.Chromaticity: X(0.252~0.274);Y(0.215~0.2622)
- d.Luminance: 4000~4800nit.
- e.Lifetime: 100000 hours.

4. BLOCK DIAGRAM

4.1 TFT LCD MODULE

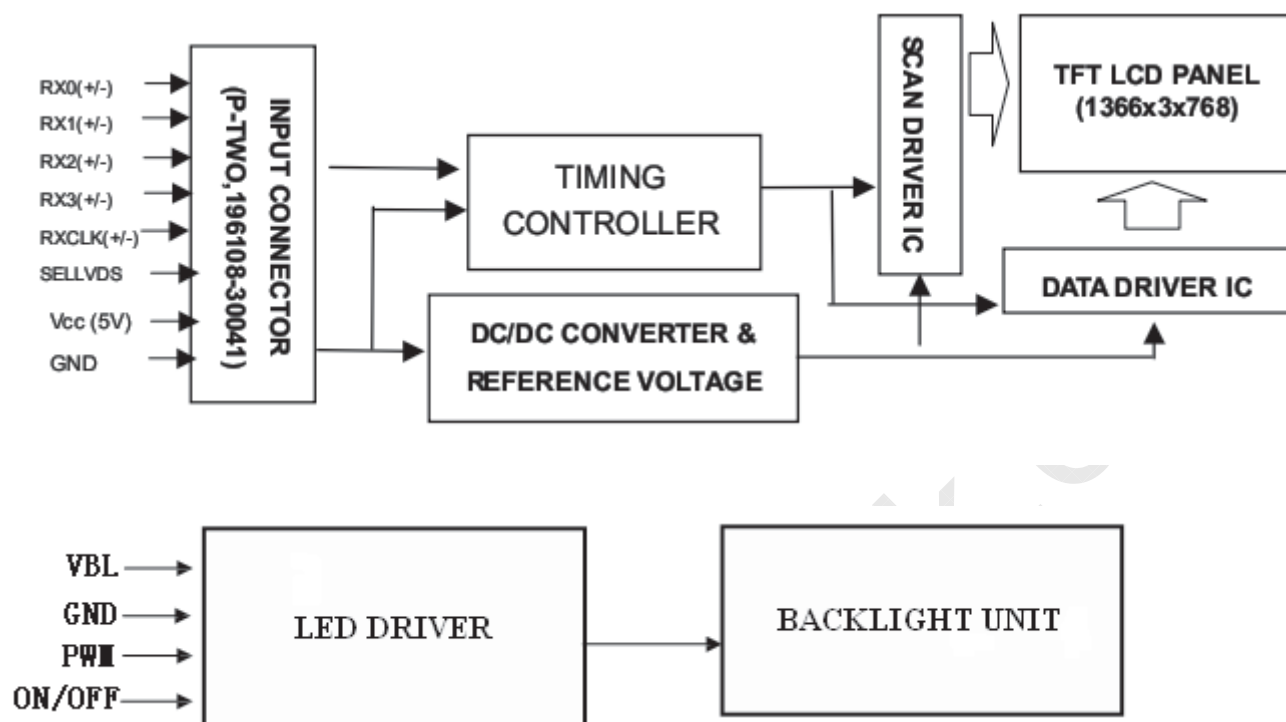

5. PIN CONNECTION

5.1 TFT LCD MODULE

Pin No.	Symbol	Description	Note
1	NC	No connection	(2)
2	NC	No connection	(2)
3	NC	No connection	(2)
4	GND	Ground	
5	RX0-	Negative transmission data of pixel 0	
6	RX0+	Positive transmission data of pixel 0	
7	GND	Ground	
8	RX1-	Negative transmission data of pixel 1	
9	RX1+	Positive transmission data of pixel 1	
10	GND	Ground	
11	RX2-	Negative transmission data of pixel 2	
12	RX2+	Positive transmission data of pixel 2	
13	GND	Ground	
14	RXCLK-	Negative of clock	
15	RXCLK+	Positive of clock	
16	GND	Ground	
17	RX3-	Negative transmission data of pixel 3	
18	RX3+	Positive transmission data of pixel 3	
19	GND	Ground	
20	NC	No connection	(2)
21	SELLVDS	Select LVDS data format	(3)
22	NC	No connection	(2)
23	GND	Ground	
24	GND	Ground	
25	GND	Ground	
26	VCC	Power supply: +5V	
27	VCC	Power supply: +5V	
28	VCC	Power supply: +5V	
29	VCC	Power supply: +5V	
30	VCC	Power supply: +5V	

Note (1) Connector part no.: P-TWO 196108-30041 (1.0mm FFC) or compatible

Note (2) Reserved for CMO internal use, please leave it open

Note (3) Low: JEIDA data format. High/open: VESA data format.

Note (4) Logic level voltage definition: Low: 0V, High: 3.3V

ODSEL	Note
L or Open	Lookup table was optimized for 60 Hz frame rate.
H	Lookup table was optimized for 50 Hz frame rate.

5.2 LVDS DATA MAPPING TABLE

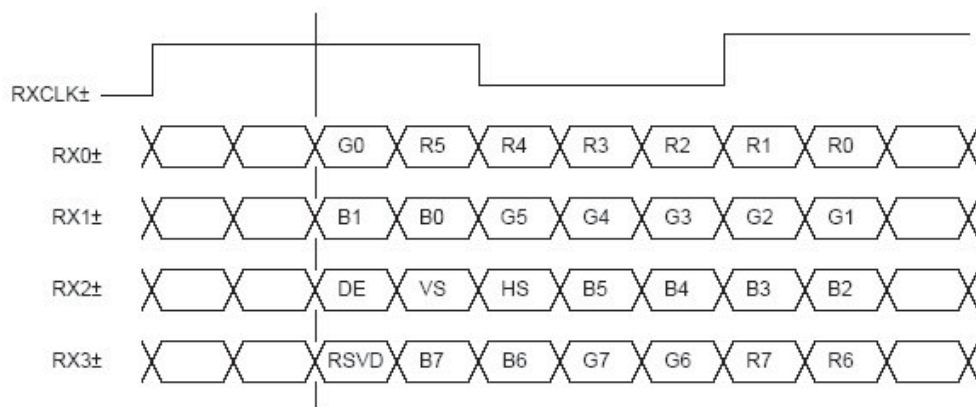
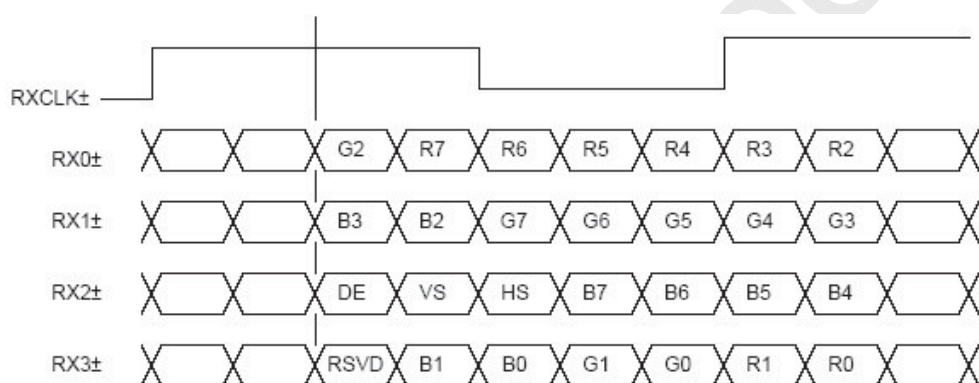
SELLVDS = H or Open (VESA)**SELLVDS = L (JEIDA)**

R0~R7: Pixel R Data (7; MSB, 0; LSB) G0~G7:

Pixel G Data (7; MSB, 0; LSB) B0~B7:

Pixel B Data (7; MSB, 0; LSB)

DE: Data enable signal

Notes(1) RSVD(reserved)pins on the transmitter shall be "H" or("L" or OPEN)

5.3 BACK LIGHT UNIT

The pin configuration for the housing and leader wire is shown in the table below.

Pin No.	Symbol	Description	Wire Color
1	V _{DC}	LED Annode	PINK
2	V _{FB}	LED Cathode	WHITE

The Backlight interface is PHR-2(JST).

5.4 COLOR DATA INPUT ASSIGNMENT

The brightness of each primary color (red, green and blue) is based on the 8-bit gray scale data input for the color. The higher the binary input, the brighter the color. The table below provides the assignment of color versus data input.

Color		Data Signal																						
		Red								Green								Blue						
		R7	R6	R5	R4	R3	R2	R1	R0	G7	G6	G5	G4	G3	G2	G1	G0	B7	B6	B5	B4	B3	B2	B1
Basic Colors	Black	0	0	0	0	0	0	0	0	0	0	0	0	0	0	0	0	0	0	0	0	0	0	0
	Red	1	1	1	1	1	1	1	1	0	0	0	0	0	0	0	0	0	0	0	0	0	0	0
	Green	0	0	0	0	0	0	0	0	1	1	1	1	1	1	1	1	0	0	0	0	0	0	0
	Blue	0	0	0	0	0	0	0	0	0	0	0	0	0	0	0	0	1	1	1	1	1	1	1
	Cyan	0	0	0	0	0	0	0	0	1	1	1	1	1	1	1	1	1	1	1	1	1	1	1
	Magenta	1	1	1	1	1	1	1	1	0	0	0	0	0	0	0	0	1	1	1	1	1	1	1
	Yellow	1	1	1	1	1	1	1	1	1	1	1	1	1	1	1	1	0	0	0	0	0	0	0
	White	1	1	1	1	1	1	1	1	1	1	1	1	1	1	1	1	1	1	1	1	1	1	1
Gray Scale Of Red	Red(0) / Dark	0	0	0	0	0	0	0	0	0	0	0	0	0	0	0	0	0	0	0	0	0	0	0
	Red(1)	0	0	0	0	0	0	0	1	0	0	0	0	0	0	0	0	0	0	0	0	0	0	0
	Red(2)	0	0	0	0	0	0	1	0	0	0	0	0	0	0	0	0	0	0	0	0	0	0	0
	:	:	:	:	:	:	:	:	:	:	:	:	:	:	:	:	:	:	:	:	:	:	:	:
	:	:	:	:	:	:	:	:	:	:	:	:	:	:	:	:	:	:	:	:	:	:	:	:
	Red(253)	1	1	1	1	1	1	0	1	0	0	0	0	0	0	0	0	0	0	0	0	0	0	0
	Red(254)	1	1	1	1	1	1	1	0	0	0	0	0	0	0	0	0	0	0	0	0	0	0	0
	Red(255)	1	1	1	1	1	1	1	1	0	0	0	0	0	0	0	0	0	0	0	0	0	0	0
Gray Scale Of Green	Green(0) / Dark	0	0	0	0	0	0	0	0	0	0	0	0	0	0	0	0	0	0	0	0	0	0	0
	Green(1)	0	0	0	0	0	0	0	0	0	0	0	0	0	0	0	1	0	0	0	0	0	0	0
	Green(2)	0	0	0	0	0	0	0	0	0	0	0	0	0	0	1	0	0	0	0	0	0	0	0
	:	:	:	:	:	:	:	:	:	:	:	:	:	:	:	:	:	:	:	:	:	:	:	:
	:	:	:	:	:	:	:	:	:	:	:	:	:	:	:	:	:	:	:	:	:	:	:	:
	Green(253)	0	0	0	0	0	0	0	0	1	1	1	1	1	1	0	1	0	0	0	0	0	0	0
	Green(254)	0	0	0	0	0	0	0	0	1	1	1	1	1	1	1	0	0	0	0	0	0	0	0
	Green(255)	0	0	0	0	0	0	0	0	1	1	1	1	1	1	1	1	0	0	0	0	0	0	0
Gray Scale Of Blue	Blue(0) / Dark	0	0	0	0	0	0	0	0	0	0	0	0	0	0	0	0	0	0	0	0	0	0	0
	Blue(1)	0	0	0	0	0	0	0	0	0	0	0	0	0	0	0	0	0	0	0	0	0	0	1
	Blue(2)	0	0	0	0	0	0	0	0	0	0	0	0	0	0	0	0	0	0	0	0	0	0	1
	:	:	:	:	:	:	:	:	:	:	:	:	:	:	:	:	:	:	:	:	:	:	:	:
	:	:	:	:	:	:	:	:	:	:	:	:	:	:	:	:	:	:	:	:	:	:	:	:
	Blue(253)	0	0	0	0	0	0	0	0	0	0	0	0	0	0	0	1	1	1	1	1	1	0	1
	Blue(254)	0	0	0	0	0	0	0	0	0	0	0	0	0	0	0	1	1	1	1	1	1	1	0
	Blue(255)	0	0	0	0	0	0	0	0	0	0	0	0	0	0	0	1	1	1	1	1	1	1	1

Note (1) 0: Low Level Voltage, 1: High Level Voltage

6. INTERFACE TIMING

6.1 INPUT SIGNAL TIMING SPECIFICATIONS

The input signal timing specifications are shown as the following table and timing diagram

Signal	Item	Symbol	Min.	Typ.	Max.	Unit	Note
LVDS Receiver Clock	Frequency	1/Tc	60	76	82	MHZ	
	Input cycle to cycle jitter	Trcl	-	-	200	ps	
LVDS Receiver Data	Setup Time	Tlvsu	600	-	-	ps	
	Hold Time	Tlvhd	600	-	-	ps	
Vertical Active Display Term	Frame Rate	Fr5	47	50	53	Hz	(2)
		Fr6	57	60	63	Hz	
	Total	Tv	778	806	888	Th	Tv=Tvd+Tvb
	Display	Tvd	768	768	768	Th	-
	Blank	Tvb	10	38	120	Th	-
Horizontal Active Display Term	Total	Th	1442	1560	1936	Tc	Th=Thd+Thb
	Display	Thd	1366	1366	1366	Tc	-
	Blank	Thb	76	194	570	Tc	-

Note(1) Since this module is operated in DE only mode, Hsync and Vsync input signals should be set to low logic level. Otherwise, this module would operate abnormally.

(2) Please refer to 5.1 for detail information.

INPUT SIGNAL TIMING DIAGRAM

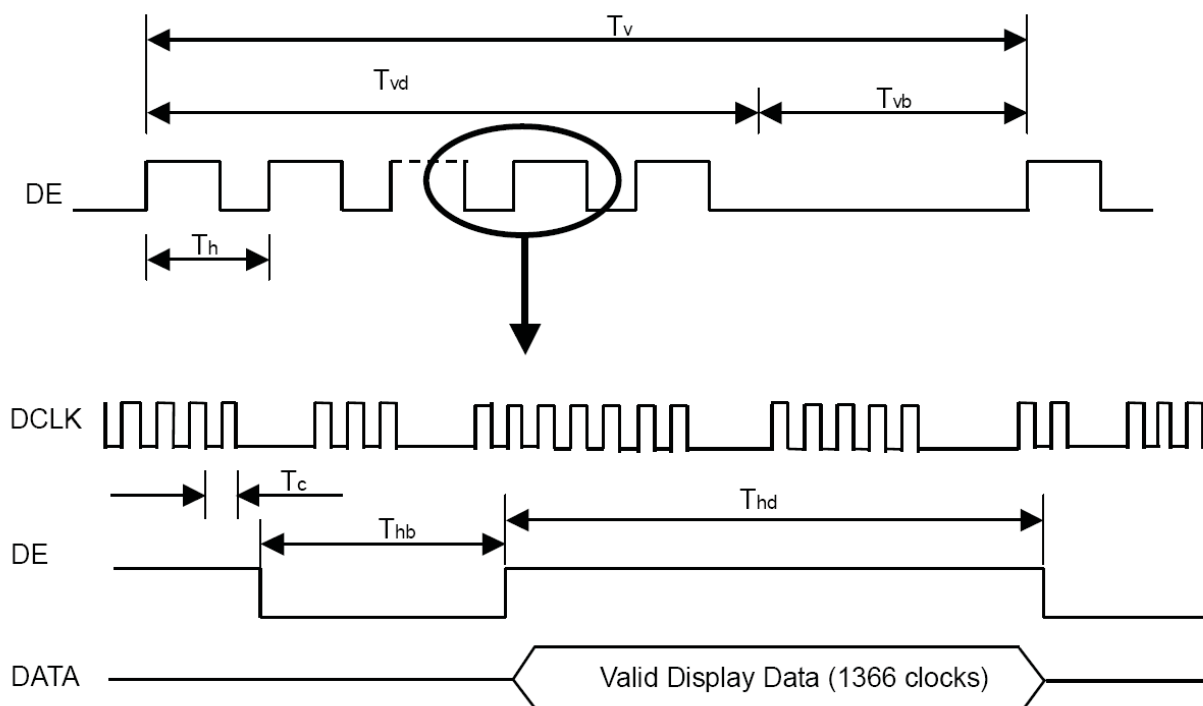

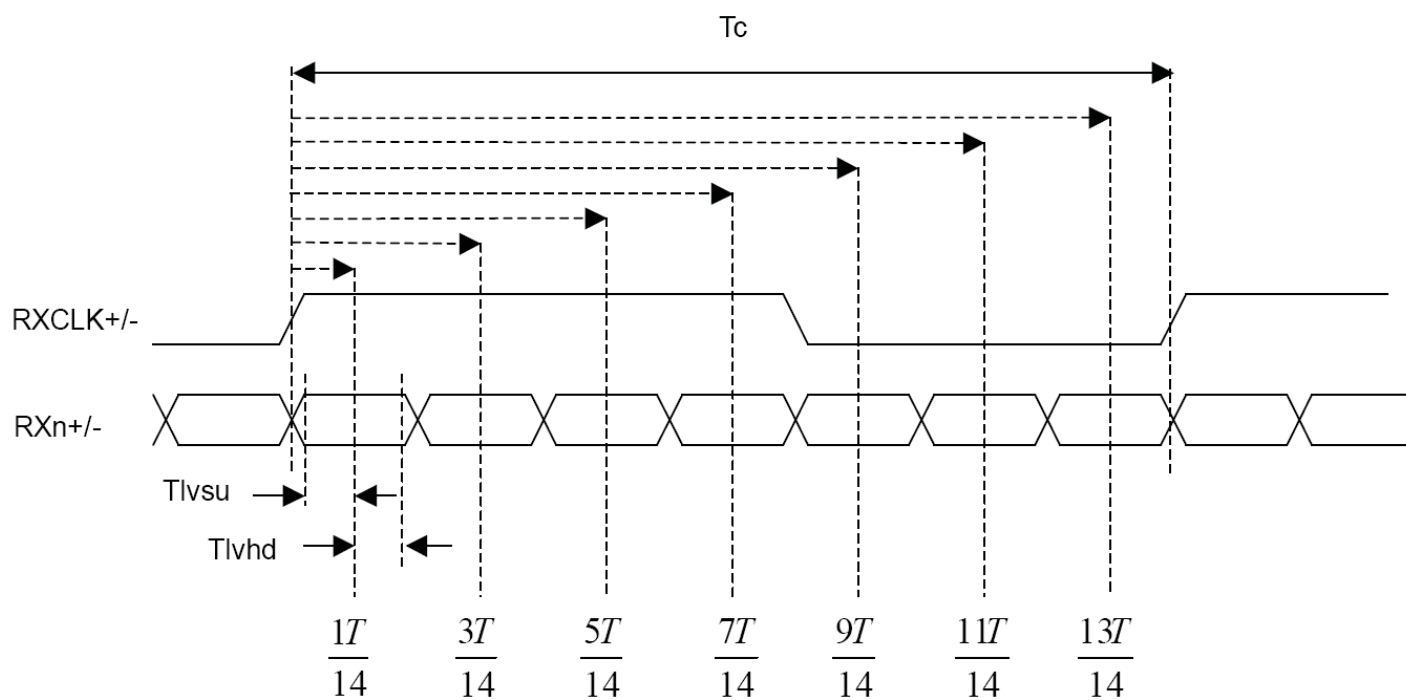
LVDS RECEIVER INTERFACE TIMING DIAGRAM

6.2 POWER ON/OFF SEQUENCE

To prevent a latch-up or DC operation of LCD module, the power on/off sequence should be as the diagram below.

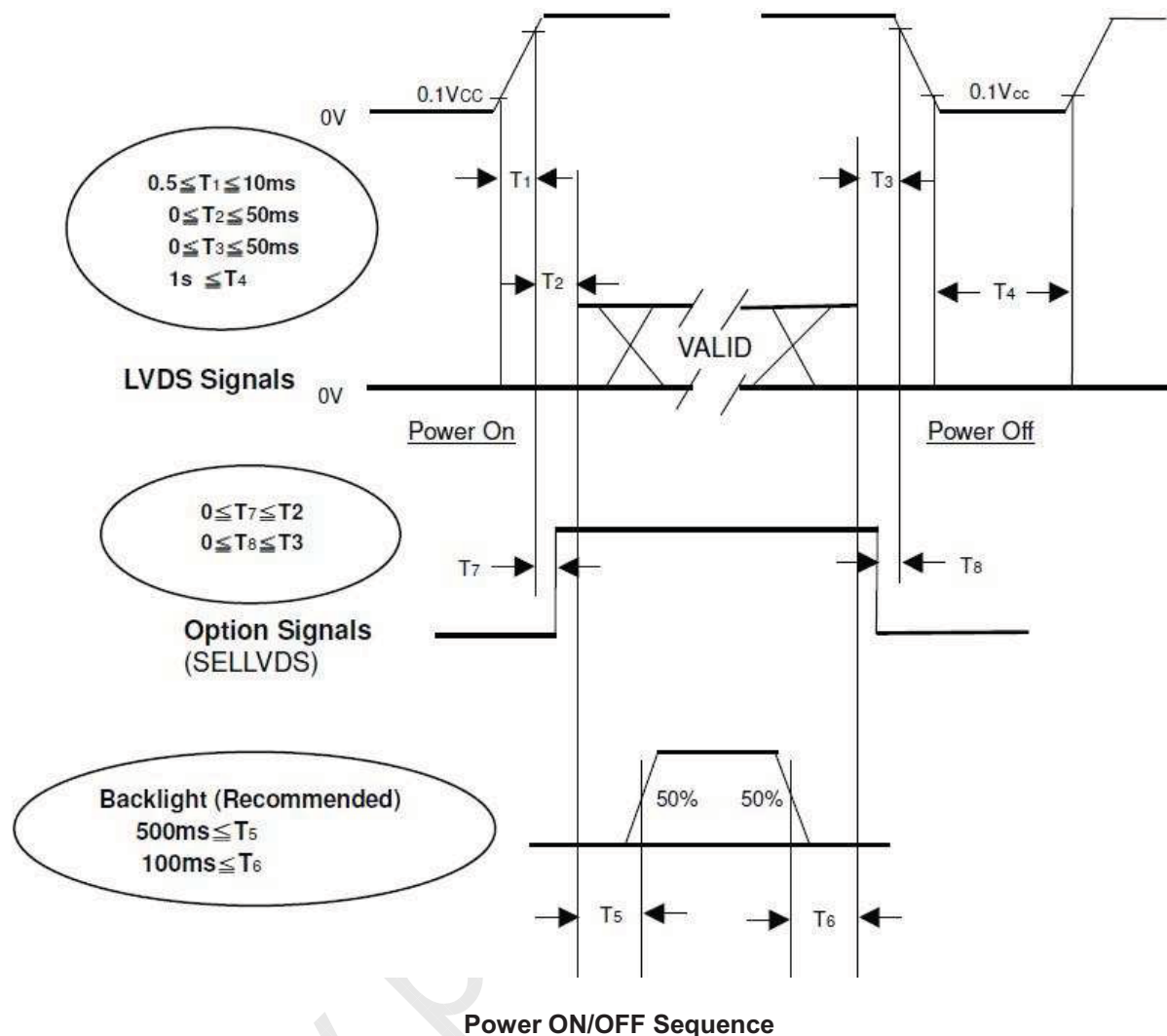

Note (1) The supply voltage of the external system for the module input should follow the definition of V_{CC}.

Note (2) Apply the lamp voltage within the LCD operation range. When the backlight turns on before the LCD operation or the LCD turns off before the backlight turns off, the display may momentarily become abnormal screen.

Note (3) In case of V_{CC} is in off level, please keep the level of input signals on the low or high impedance. If T₂ < 0, that maybe cause electrical overstress failures.

Note (4) T₄ should be measured after the module has been fully discharged between power off and on period.

Note (5) Interface signal shall not be kept at high impedance when the power is on.

7. OPTICAL CHARACTERISTICS

7.1 TEST CONDITIONS

Item	Symbol	Value	Unit
Ambient Temperature	Ta	25±2	°C
Ambient Humidity	Ha	50±10	%RH
Supply Voltage	VCC	5.0	V
Input Signal	According to typical value in "3. ELECTRICAL CHARACTERISTICS"		
LED Current	IL	65 ± 0.5	mA
Oscillating Frequency (Inverter)	FW	63±3	KHz
Frame rate	Fr	60	Hz

7.2 OPTICAL CHARACTERISTICS

The relative measurement methods of optical characteristics are shown in 7.2. The following items should be measured under the test conditions described in 7.1 and stable environment shown in Note (6).

Item		Symbol	Condition	Min.	Typ.	Max.	Unit	Note
Contrast Ratio		CR	$\theta_x=0^\circ, \theta_y=0^\circ$	(600)	(800)	-	-	(2)
Response Time		Gray to gray average		-	(6.5)	(12)	ms	(3)
Center Luminance of White		L _c			250	-	cd/m ²	(4)
White Variation		δW			75%	80%-	-	(7)
Cross Talk		CT			-	-	4.0	%
Color Chromaticity	Red	Rx	Viewing Angle at Normal Direction	Typ -0.03	(0.642)	Typ +0.03	-	(6)
		Ry			(0.332)		-	
	Green	Gx			(0.277)		-	
		Gy			(0.592)		-	
	Blue	Bx			(0.145)		-	
		By			(0.066)		-	
	White	Wx			0.285		-	
		Wy			0.293		-	
Color Gamut		CG			72	%	NTSC	
Viewing Angle	Horizontal	θ_{x+}	CR≥20	75	85	-	Deg.	(1)
		θ_{x-}		75	85	-		
	Vertical	θ_{y+}		70	80	-		
		θ_{y-}		70	80	-		

Note (1) Definition of Viewing Angle (θ_x , θ_y):

Viewing angles are measured by EZ-Contrast 160R (Eldim)

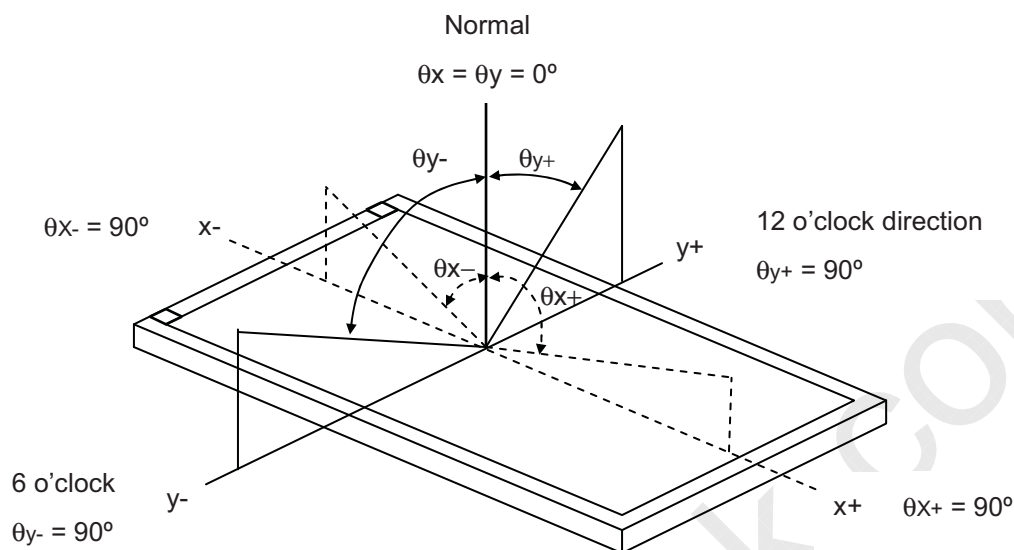

Note (2) Definition of Contrast Ratio (CR):

The contrast ratio can be calculated by the following expression.

$$\text{Contrast Ratio (CR)} = L_{255} / L_0$$

L255: Luminance of gray level 255

L 0: Luminance of gray level 0

CR = CR (5), where CR (X) is corresponding to the Contrast Ratio of the point X at the figure in Note (7).

Note (3) Definition of Response Time (T_R , T_F):

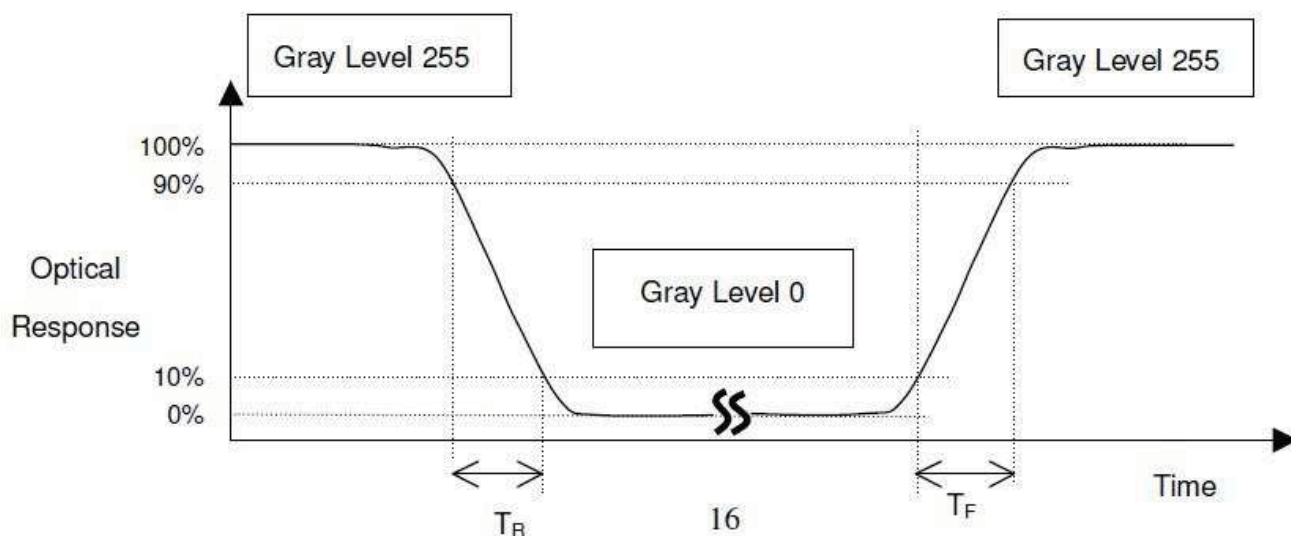

The driving signal means the signal of luminance 0%, 20%, 40%, 60%, 80%, 100%. Gray to gray average time means the average switching time of luminance 0%, 20%, 40%, 60%, 80%, 100% to each other.

Note (4) Definition of Luminance of White (L_C , L_{AVE}):

Measure the luminance of gray level 255 at center point and 5 points

$$L_C = L(5),$$

$$L_{AVE} = [L(1) + L(2) + L(3) + L(4) + L(5)] / 5$$

where $L(X)$ is corresponding to the luminance of the point X at the figure in Note (7).

Note (5) Definition of Cross Talk (CT):

$$CT = |Y_B - Y_A| / Y_A \times 100 (\%)$$

Where:

Y_A = Luminance of measured location without gray level 0 pattern (cd/m^2)

Y_B = Luminance of measured location with gray level 0 pattern (cd/m^2)

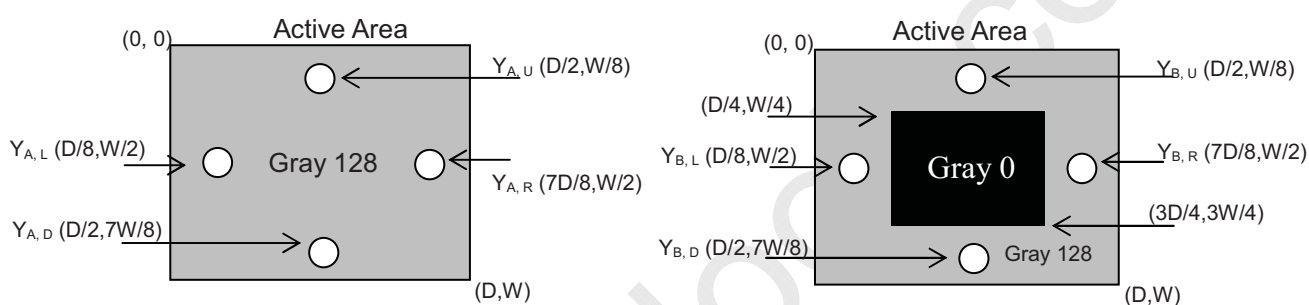

Note (6) Measurement Setup:

The LCD module should be stabilized at given temperature for 1 hour to avoid abrupt temperature change during measuring. In order to stabilize the luminance, the measurement should be executed after lighting Backlight for 1 hour in a windless room.

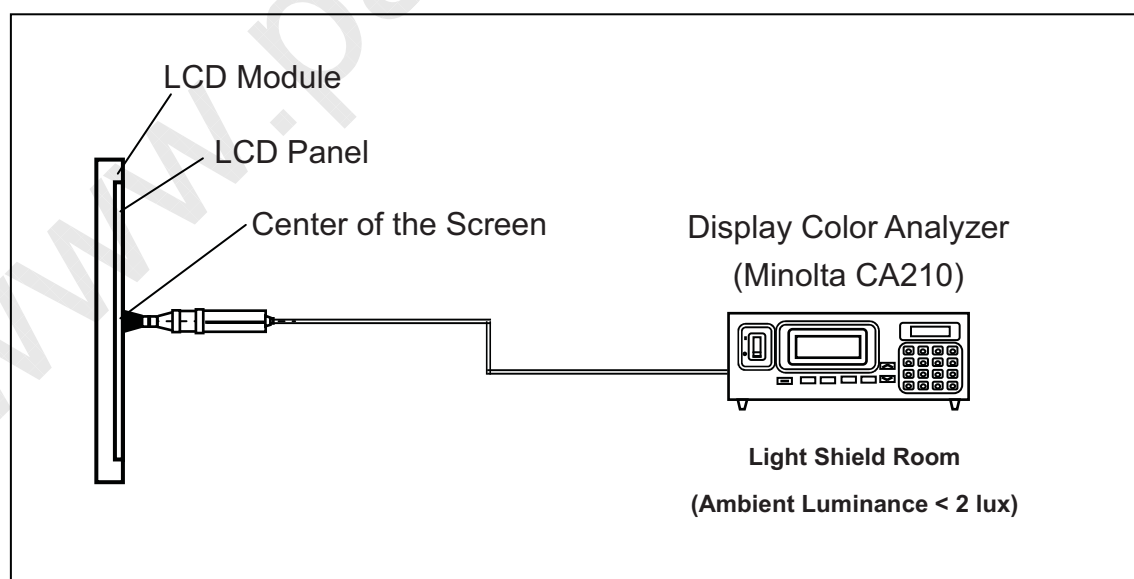

Note (7) Definition of White Variation (δW) :

Measure the luminance of gray level 255 at 5 points

$$\delta W = \text{Maximum } [L(1), L(2), L(3), L(4), \dots, L(5)] / \text{Minimum } [L(1), L(2), L(3), L(4), \dots, L(5)]$$

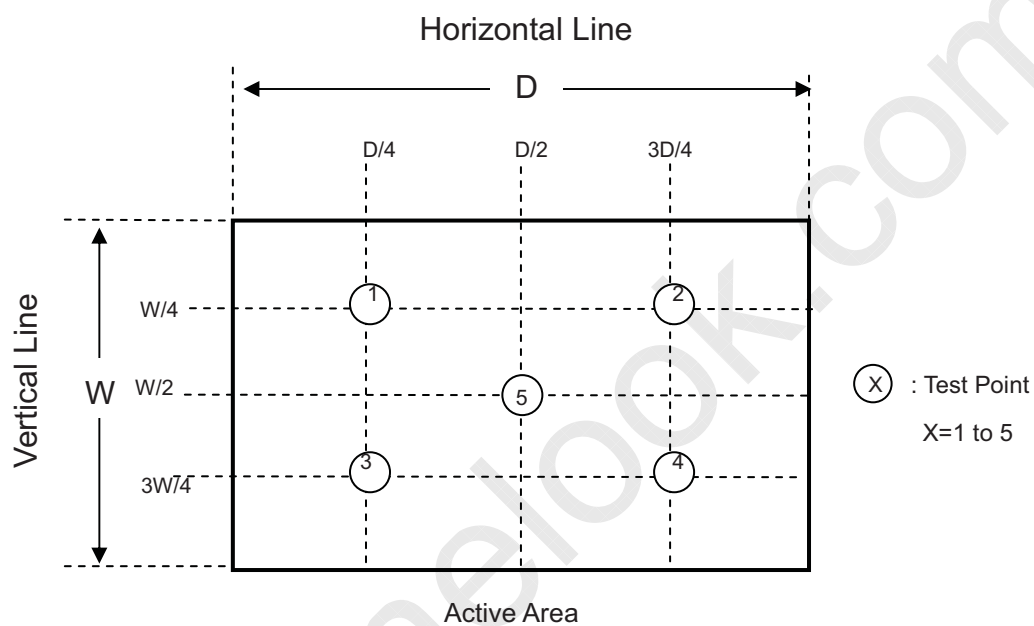

8. DEFINITION OF LABELS

8.1 ASSEMBLY LCD MODULE LABEL

The barcode nameplate is pasted on each module as illustration, and its definitions are as following explanation.

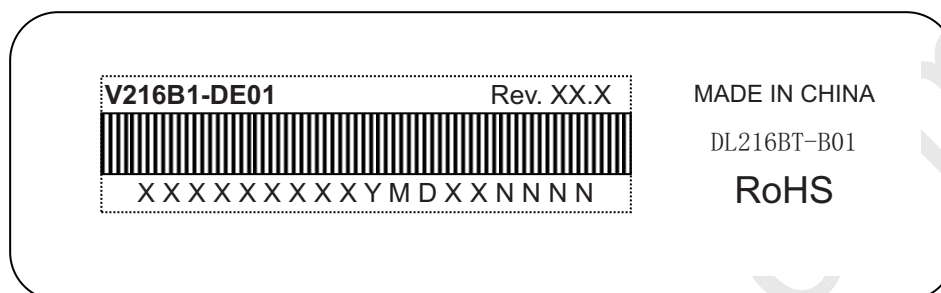

(a) Model Name:V216B1-DE01

(b) Revise: Rev. XX.X, for example:A2.0,A2.1...etc.

(c) Serial ID: X X X XX XX X X X Y M D XX N N N N

(d)

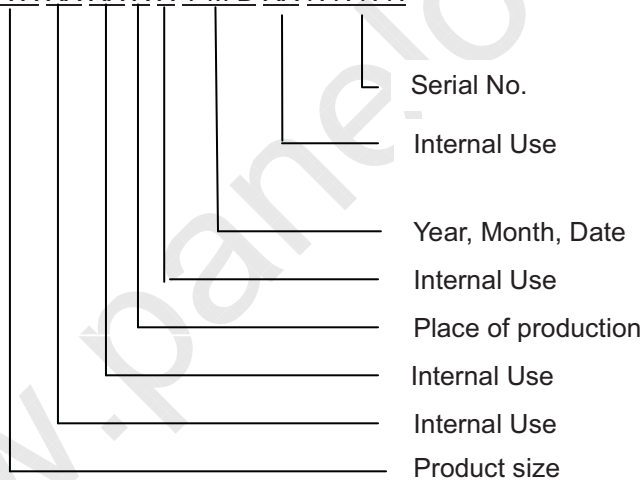

Serial ID includes the information as below:

- (a) Manufactured Date: Year: 1~9, for 2001~2009
 Month: 1~9, A~C, for Jan. ~ Dec.
 Day: 1~9, A~Y, for 1st to 31st, exclude I ,O, and U.
- (b) Revision Code: Cover all the change
- (c) Serial No.: Manufacturing sequence of product

9. PACKAGING

9.1 PACKING SPECIFICATIONS

- (1) 8PCS LCD modules / 1 Box
- (2) Box dimensions: 568mm(L)*410mm(W)*300mm(H)
- (3) Weight: approximately 20.4 Kg (8 modules per box)

9.2 PACKING METHOD

- a. Opencell surface should keep the same direction to the marked of base triangle
- b. When placed pallets ,the obverse of boxes should put inside.
- c. PP Belt:W13mm*T0.6mm
- d. Corner Protector: L1130mm*H50mm*W50mm
- e.Film W360mm*T0.05mm
- f.Pallet:TBD

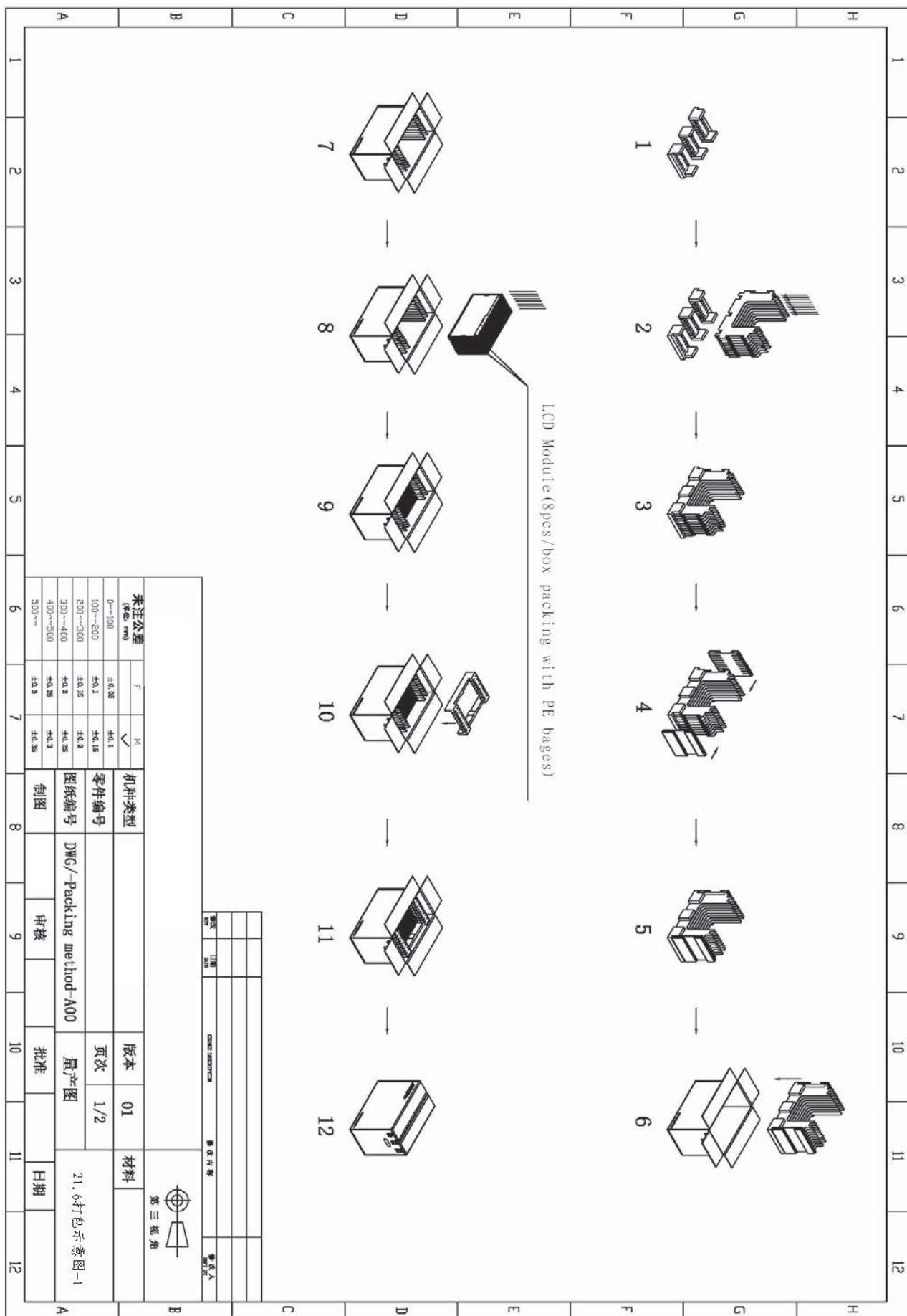

10. PRECAUTIONS

10.1 ASSEMBLY AND HANDLING PRECAUTIONS

- (1) Do not apply rough force such as bending or twisting to the module during assembly.
- (2) It is recommended to assemble or to install a module into the user's system in clean working areas.
The dust and oil may cause electrical short or worsen the polarizer.
- (3) Do not apply pressure or impulse to the module to prevent the damage of LCD panel and backlight.
- (4) Always follow the correct power-on sequence when the LCD module is turned on. This can prevent the damage and latch-up of the CMOS LSI chips.
- (5) Do not plug in or pull out the I/F connector while the module is in operation.
- (6) Do not disassemble the module.
- (7) Use a soft dry cloth without chemicals for cleaning, because the surface of polarizer is very soft and easily scratched.
- (8) Moisture can easily penetrate into LCD module and may cause the damage during operation.
- (9) High temperature or humidity may deteriorate the performance of LCD module. Please store LCD modules in the specified storage conditions.

10.2 SAFETY PRECAUTIONS

- (1) The startup voltage of a backlight is over 1000 Volts. It may cause an electrical shock while assembling with the inverter. Do not disassemble the module or insert anything into the backlight unit.
- (2) If the liquid crystal material leaks from the panel, it should be kept away from the eyes or mouth. In case of contact with hands, skin or clothes, it has to be washed away thoroughly with soap.
- (3) After the module's end of life, it is not harmful in case of normal operation and storage.

10.3 STORAGE PRECAUTIONS

When storing modules as spares for a long time, the following precaution is necessary.

- (1) Do not leave the module in high temperature, and high humidity for a long time.
It is highly recommended to store the module with temperature from 0 to 35°C at normal humidity without condensation.
- (2) The module shall be stored in dark place. Do not store the TFT-LCD module in direct sunlight or fluorescent light.

11. MECHANICAL CHARACTERISTICS

