

TFT LCD Approval Specification

MODEL NO.: V216B1- L05

Customer: **Common**

Approved by: _____

Note:

核准時間	部門	審核	角色	投票
2010-03-02 11:50:52	MTR 產品管理處	<div style="text-align: center;">  </div>	Director	Accept

CONTENTS

REVISION HISTORY	-----	3
1. GENERAL DESCRIPTION	-----	4
1.1 OVERVIEW		
1.2 FEATURES		
1.3 GENERAL		
1.4 MECHANICAL		
2. ABSOLUTE MAXIMUM RATINGS	-----	5
2.1 ABSOLUTE RATINGS OF ENVIRONMENT		
2.2 TFT LCD MODULE		
2.3 BACKLIGHT UNIT		
3. ELECTRICAL CHARACTERISTICS	-----	7
3.1 TFT LCD MODULE		
3.2 CCFL (Cold Cathode Fluorescent Lamp) CHARACTERISTICS		
4. BLOCK DIAGRAM	-----	11
4.1 TFT LCD MODULE		
5. INPUT TERMINAL PIN ASSIGNMENT	-----	12
5.1 TFT LCD MODULE		
5.2 LVDS DATA MAPPING TABLE		
5.3 BACKLIGHT UNIT		
5.4 COLOR DATA INPUT ASSIGNMENT		
5.5 BLOCK DIAGRAM OF INTERFACE		
6. INTERFACE TIMING	-----	18
6.1 INPUT SIGNAL TIMING SPECIFICATIONS		
6.2 POWER ON/OFF SEQUENCE		
7. OPTICAL CHARACTERISTICS	-----	22
7.1 TEST CONDITIONS		
7.2 OPTICAL SPECIFICATIONS		
8. DEFINITION OF LABELS	-----	26
8.1 CMO MODULE LABEL		
9. PACKAGING	-----	27
9.1 PACKING SPECIFICATIONS		
9.2 PACKING METHOD		
10. PRECAUTIONS	-----	29
10.1 ASSEMBLY AND HANDLING PRECAUTIONS		
10.2 SAFETY PRECAUTIONS		
10.3 SAFETY STANDARDS		
11. MECHANICAL CHARACTERISTICS	-----	30

REVISION HISTORY

Version	Date	Page (New)	Section	Description
Ver 3.0	Feb. 26,'10	All	All	Approval Specification was first issued.

1. GENERAL SPECIFICATIONS

1.1 OVERVIEW

The V216B1-L05 model is a 21.6 inch wide TFT-LCD module with a 4-CCFL Backlight Unit and a 30-pin 1ch-LVDS interface. This module supports 1366 x 768 (16:9 wide screen) mode and displays up to 16.7 (6-bit+Hi-FRC colors) millions colors. The inverter module for the Backlight Unit is not built in.

1.2 FEATURES

- Excellent Brightness: 400nits
- Contrast Ratio:1000:1
- Fast Response Time: 5ms
- Color Saturation: NTSC 72%
- WXGA (1366 x 768 pixels) Resolution
- DE (Data Enable) Only Mode
- LVDS (Low Voltage Differential Signaling) Interface
- Viewing Angle: 170(H)/160(V) (CR>10) TN Technology
- Color Reproduction (Nature Color)

1.3 GENERAL

Item	Specification	Unit	Note
Active Area	477.417 (H) x 268.416 (V) (21.6" diagonal)	mm	
Bezel Opening Area	481.5 (H) x 272.5 (V)	mm	
Driver Element	a-si TFT active matrix	-	
Pixel Number	1366 x R.G.B. x 768	pixel	
Pixel Pitch (Sub Pixel)	0.1165 (H) x 0.3495 (V)	mm	
Pixel Arrangement	RGB vertical stripe	-	
Display Colors	16.7 millions	color	
Display Operation Mode	Transmissive mode / Normally White	-	
Surface Treatment	Hard coating (3H), AG (Haze 25%)	-	

1.4 MECHANICAL

Item	Min.	Typ.	Max.	Unit	Note	
Module Size	Horizontal(H)	500.3	501	501.7	mm	
	Vertical(V)	296.4	297	297.6	mm	
	Depth(D)	16.8	17.3	17.8	mm	To PCB cover
Weight	Na	2350	Na	g		

2. ABSOLUTE MAXIMUM RATINGS

2.1 ABSOLUTE RATINGS OF ENVIRONMENT

Item	Symbol	Value		Unit	Note
		Min.	Max.		
Storage Temperature	T_{ST}	-20	+60	°C	(1)
Operating Ambient Temperature	T_{OP}	0	+50	°C	(1), (2)
Shock (Non-Operating)	S_{NOP}	-	50	G	(3), (5)
Vibration (Non-Operating)	V_{NOP}	-	1.0	G	(4), (5)

Note (1) Temperature and relative humidity range is shown in the figure below.

(a) 90% RH Max. ($T_a \leq 40$ °C).

(b) Wet-bulb temperature should be 39 °C Max. ($T_a > 40$ °C).

(c) No condensation.

Note (2) The maximum operating temperature is based on the test condition that the surface temperature of display area is less than or equal to 65 °C with LCD module alone in a temperature controlled chamber. Thermal management should be considered in final product design to prevent the surface temperature of display area from being over 65 °C. The range of operating temperature may degrade in case of improper thermal management in final product design.

Note (3) 11 ms, half-sine wave, 1 time for $\pm X$, $\pm Y$, $\pm Z$.

Note (4) 10 ~ 200 Hz, 10 min, 1 time each X, Y, Z.

Note (5) At testing Vibration and Shock, the fixture in holding the module has to be hard and rigid enough so that the module would not be twisted or bent by the fixture.

Relative Humidity (%RH)

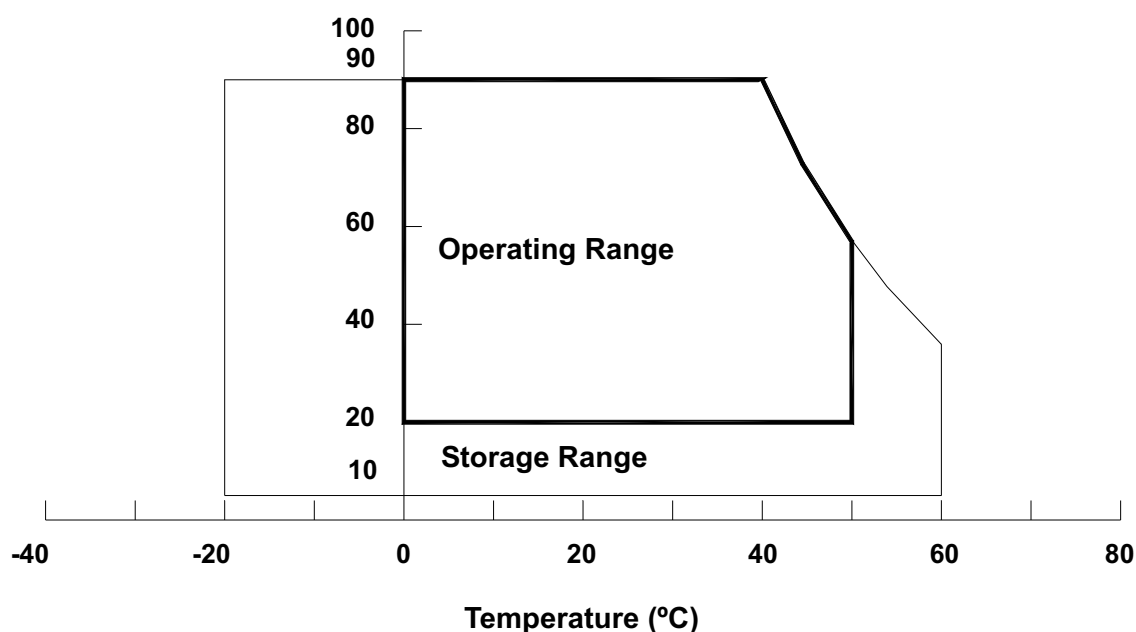

2.2 TFT LCD MODULE

Item	Symbol	Value		Unit	Note
		Min.	Max.		
Power Supply Voltage	V _{CC}	-0.3	6.0	V	
Input Signal Voltage	V _{IN}	-0.3	3.6	V	

2.3 BACKLIGHT UNIT

Item	Symbol	Test Condition	Min.	Type	Max.	Unit	Note
Lamp Voltage	V _W	Ta = 25 °C	—	—	3000	V _{RMS}	

Note (1) Permanent damage to the device may occur if maximum values are exceeded. Functional operation should be restricted to the conditions described under normal operating conditions.

Note (2) No moisture condensation or freezing.

3. ELECTRICAL CHARACTERISTICS**3.1 TFT LCD MODULE**

Ta = 25 ±2 °C

Parameter		Symbol	Value			Unit	Note
			Min.	Typ.	Max.		
Power Supply Voltage		V _{CC}	4.5	5.0	5.5	V	(1)
Power Supply Ripple Voltage		V _{RP}	-	-	150	mV	
Rush Current		I _{RUSH}	-	-	3.0	A	(2)
Power Supply Current	White	I _{CC}	-	0.50	-	A	(3)
	Black		-	0.85	0.95	A	
	Vertical Stripe		-	0.75	-	A	
LVDS Interface	Differential Input High Threshold Voltage	V _{LVTH}	+100	-	-	mV	(4)
	Differential Input Low Threshold Voltage	V _{LVTL}	-	-	-100	mV	
	Common Input Voltage	V _{LVC}	1.125	1.25	1.375	V	
	Differential input voltage	V _{ID}	200	-	600	mV	
	Terminating Resistor	R _T	-	100	-	ohm	
CMOS interface	Input High Threshold Voltage	V _{IH}	2.7	-	3.3	V	
	Input Low Threshold Voltage	V _{IL}	0	-	0.7	V	

Note (1) The module should be always operated within above ranges.

Note (2) Measurement Conditions:

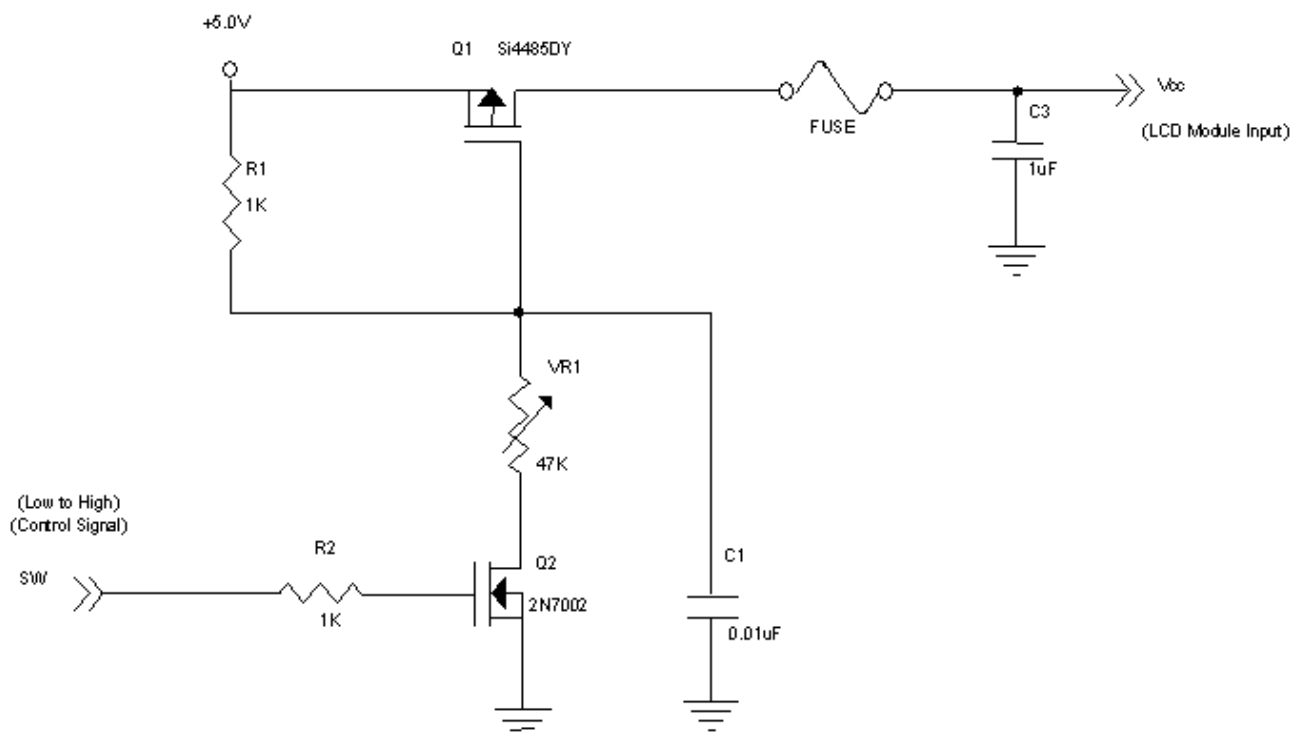

Vcc rising time is 470us

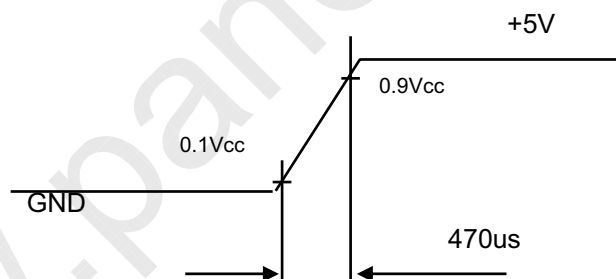

Note (3) The specified power supply current is under the conditions at $V_{CC} = 5\text{ V}$, $T_a = 25 \pm 2\text{ }^\circ\text{C}$, $f_v = 60\text{ Hz}$, whereas a power dissipation check pattern below is displayed.

a. White Pattern

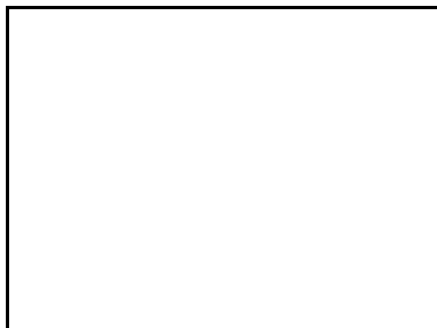

Active Area

b. Black Pattern

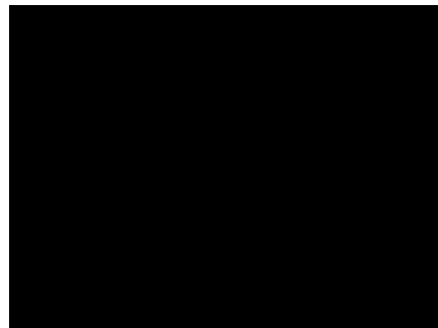

Active Area

c. Vertical Stripe Pattern

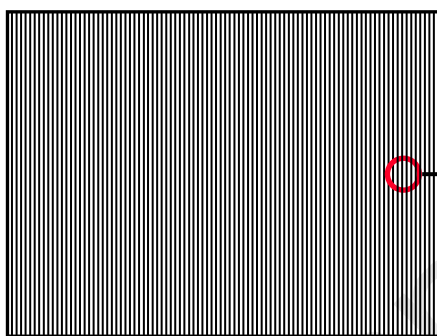

Active Area



Note (4) The LVDS input characteristics are as follows:

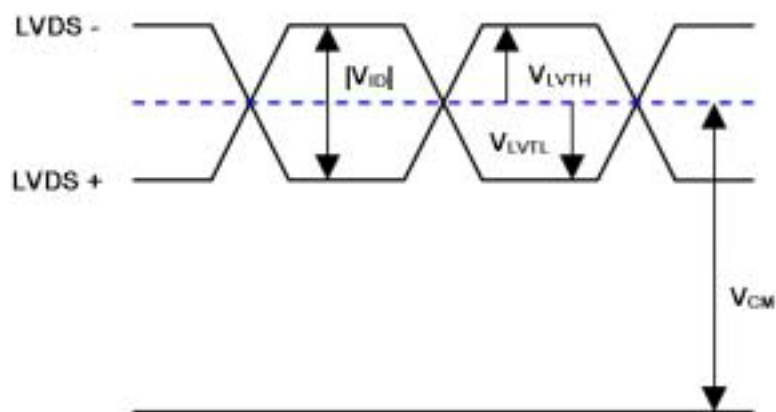

3.2 CCFL (Cold Cathode Fluorescent Lamp) CHARACTERISTICS (Ta = 25 ± 2 °C)

Parameter	Symbol	Value			Unit	Note
		Min.	Typ.	Max.		
Lamp Voltage	V _W	-	920	-	V _{RMS}	I _L = 4.5mA
Lamp Current	I _L	4.0	4.5	5.0	mA _{RMS}	
Lamp Turn On Voltage	V _S			1250	V _{RMS}	(2), Ta = 25 °C
				1450	V _{RMS}	(2), Ta = 0 °C
Operating Frequency	F _L	30		80	KHz	(3)
Lamp Life Time	L _{BL}	50000			Hrs	(4)

Note (1) The waveform of the voltage output of inverter must be area-symmetric and the design of the inverter must have specifications for the modularized lamp. The performance of the Backlight, such as lifetime or brightness, is greatly influenced by the characteristics of the DC-AC inverter for the lamp. All the parameters of an inverter should be carefully designed to avoid producing too much current leakage from high voltage output of the inverter. When designing or ordering the inverter please make sure that a poor lighting caused by the mismatch of the Backlight and the inverter (miss-lighting, flicker, etc.) never occurs. If the above situation is confirmed, the module should be operated in the same manners when it is installed in your instrument.

Note (2) The lamp starting voltage V_S should be applied to the lamp for more than 1 second after startup. Otherwise the lamp may not be turned on.

Note (3) The lamp frequency may produce interference with horizontal synchronous frequency of the display input signals, and it may result in line flow on the display. In order to avoid interference, the lamp frequency should be detached from the horizontal synchronous frequency and its harmonics as far as possible.

Note (4) The life time of a lamp is defined as when the brightness is larger than 50% of its original value and the effective discharge length is longer than 80% of its original length (Effective discharge length is defined as an area that has equal to or more than 70% brightness compared to the brightness at the center point of lamp.) as the time in which it continues to operate under the condition at Ta = 25 ± 2°C and I_L = 4.5 mA_{RMS}.



4. BLOCK DIAGRAM

4.1 TFT LCD MODULE

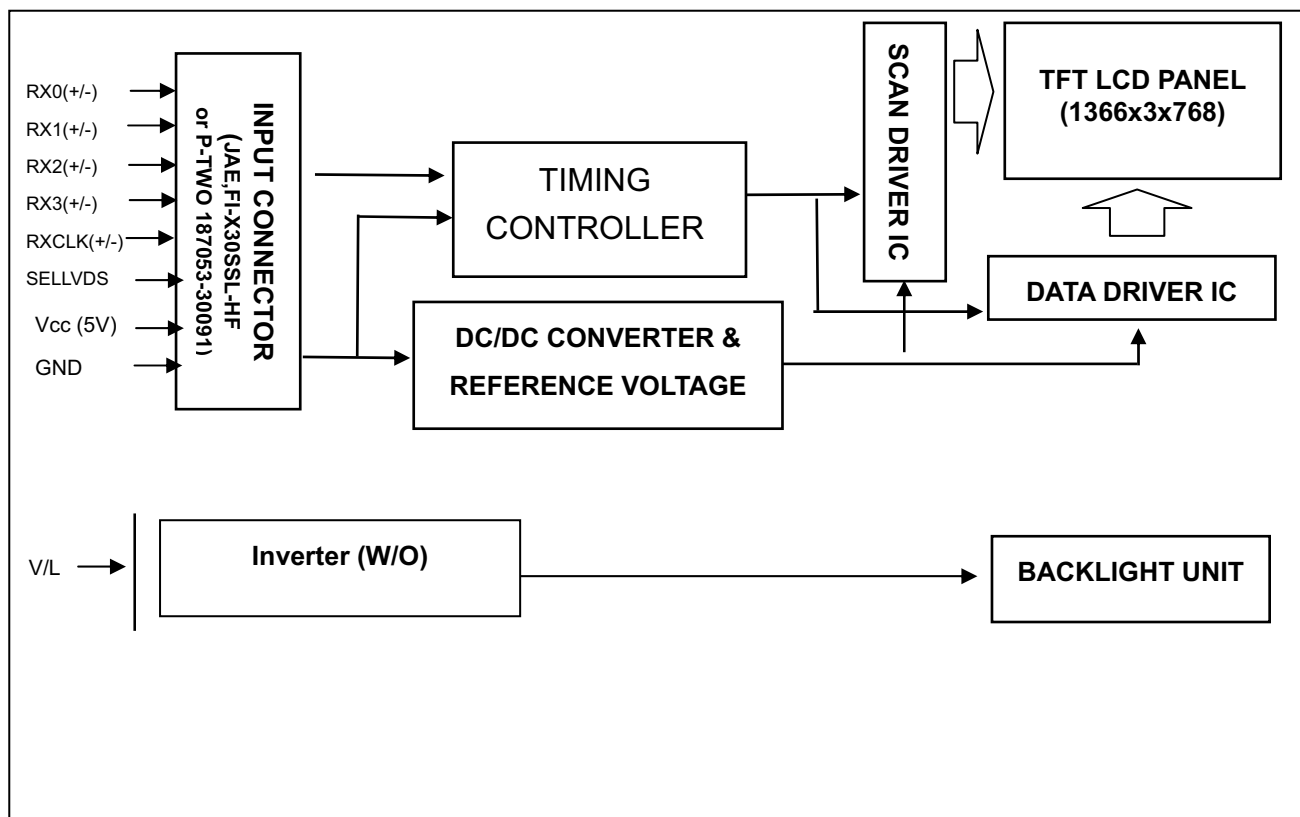

5. INPUT TERMINAL PIN ASSIGNMENT

5.1 TFT LCD MODULE

Pin No.	Symbol	Description	Note
1	NC	No Connection	(2)
2	NC	No Connection	(2)
3	NC	No Connection	(2)
4	GND	Ground	
5	RX0-	Negative transmission data of pixel 0	
6	RX0+	Positive transmission data of pixel 0	
7	GND	Ground	
8	RX1-	Negative transmission data of pixel 1	
9	RX1+	Positive transmission data of pixel 1	
10	GND	Ground	
11	RX2-	Negative transmission data of pixel 2	
12	RX2+	Positive transmission data of pixel 2	
13	GND	Ground	
14	RXCLK-	Negative of clock	
15	RXCLK+	Positive of clock	
16	GND	Ground	
17	RX3-	Negative transmission data of pixel 3	
18	RX3+	Positive transmission data of pixel 3	
19	GND	Ground	
20	NC	No Connection	(2)
21	SELLVDS (Default:VESA)	Select LVDS data format	(3) (4)
22	NC	No Connection	(2)
23	GND	Ground	
24	GND	Ground	
25	GND	Ground	
26	VCC	Power supply: +5V	
27	VCC	Power supply: +5V	
28	VCC	Power supply: +5V	
29	VCC	Power supply: +5V	
30	VCC	Power supply: +5V	

Note (1) Connector part no.: JAE,FI-X30SSL-HF or P-TWO 187053-30091

LVDS connector pin order defined as follows

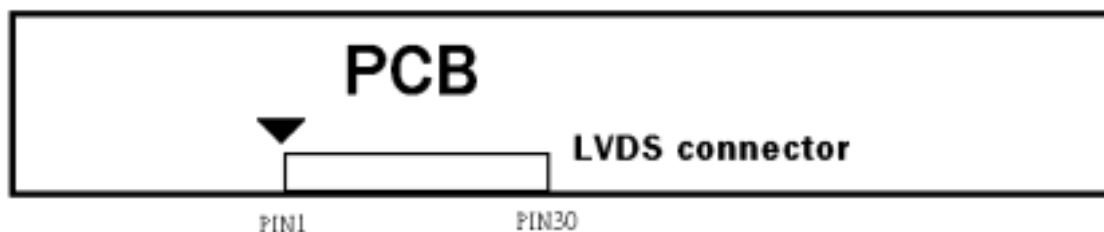

Note (2) Reserved for CMO internal use, please leave it open

Note (3) Low = Connect to GND: JEIDA Format, High = connect to +3.3V or Open : VESA Format.

Please refer to 5.2 LVDS INTERFACE

Note (4) LVDS signal pin connected to the LCM side has the following diagram.

R1 in the system side should be less than 1K Ohm. ($R1 < 1K \text{ Ohm}$)

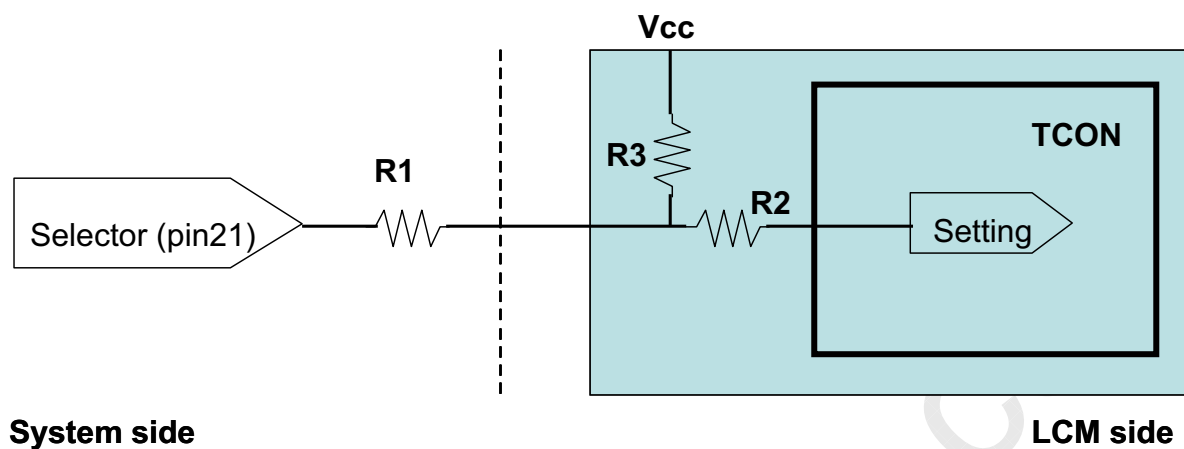

System side

LCM side

5.2 LVDS DATA MAPPING TABLE

VESA LVDS format : (SELLVDS pin=H or Open)

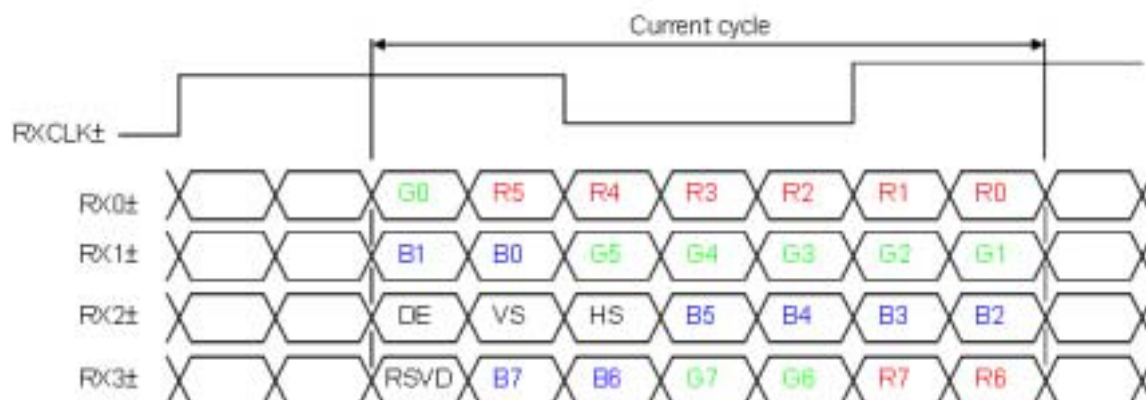

JEDIA LVDS format : (SELLVDS pin=L)

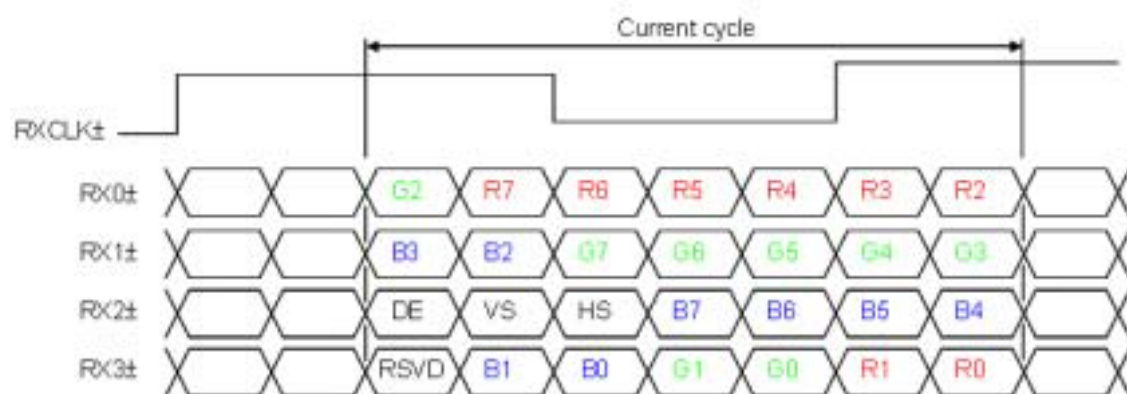

R0~R7: Pixel R Data (7; MSB, 0; LSB)

G0~G7: Pixel G Data (7; MSB, 0; LSB)

B0~B7: Pixel B Data (7; MSB, 0; LSB)

DE: Data enable signal

Notes(1) RSVD(reserved)pins on the transmitter shall be "H" or("L" or OPEN)

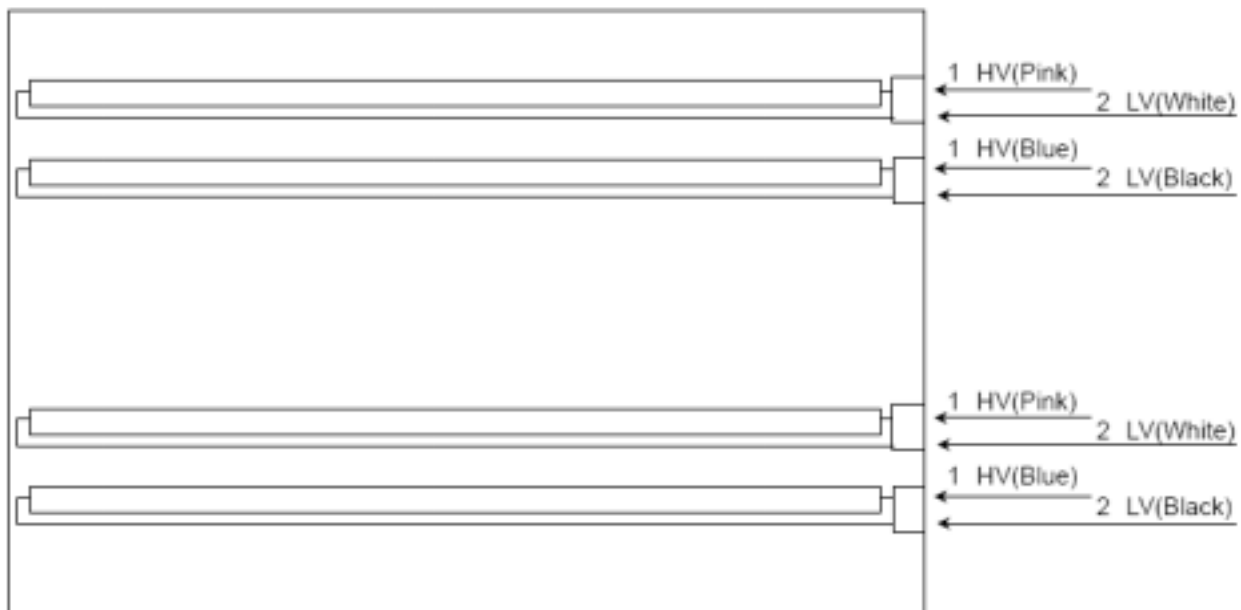
5.3 BACKLIGHT UNIT

5.4 COLOR DATA INPUT ASSIGNMENT

The brightness of each primary color (red, green and blue) is based on the 8-bit gray scale data input for the color. The higher the binary input, the brighter the color. The table below provides the assignment of color versus data input.

Color		Data Signal																						
		Red								Green								Blue						
		R7	R6	R5	R4	R3	R2	R1	R0	G7	G6	G5	G4	G3	G2	G1	G0	B7	B6	B5	B4	B3	B2	B1
Basic Colors	Black	0	0	0	0	0	0	0	0	0	0	0	0	0	0	0	0	0	0	0	0	0	0	0
	Red	1	1	1	1	1	1	1	1	0	0	0	0	0	0	0	0	0	0	0	0	0	0	0
	Green	0	0	0	0	0	0	0	0	1	1	1	1	1	1	1	1	0	0	0	0	0	0	0
	Blue	0	0	0	0	0	0	0	0	0	0	0	0	0	0	0	0	1	1	1	1	1	1	1
	Cyan	0	0	0	0	0	0	0	0	1	1	1	1	1	1	1	1	1	1	1	1	1	1	1
	Magenta	1	1	1	1	1	1	1	1	0	0	0	0	0	0	0	0	1	1	1	1	1	1	1
	Yellow	1	1	1	1	1	1	1	1	1	1	1	1	1	1	1	1	0	0	0	0	0	0	0
	White	1	1	1	1	1	1	1	1	1	1	1	1	1	1	1	1	1	1	1	1	1	1	1
Gray Scale Of Red	Red(0) / Dark	0	0	0	0	0	0	0	0	0	0	0	0	0	0	0	0	0	0	0	0	0	0	
	Red(1)	0	0	0	0	0	0	0	1	0	0	0	0	0	0	0	0	0	0	0	0	0	0	
	Red(2)	0	0	0	0	0	0	1	0	0	0	0	0	0	0	0	0	0	0	0	0	0	0	
	:	:	:	:	:	:	:	:	:	:	:	:	:	:	:	:	:	:	:	:	:	:	:	
	:	:	:	:	:	:	:	:	:	:	:	:	:	:	:	:	:	:	:	:	:	:	:	
	Red(253)	1	1	1	1	1	1	0	1	0	0	0	0	0	0	0	0	0	0	0	0	0	0	
	Red(254)	1	1	1	1	1	1	1	0	0	0	0	0	0	0	0	0	0	0	0	0	0	0	
	Red(255)	1	1	1	1	1	1	1	1	0	0	0	0	0	0	0	0	0	0	0	0	0	0	
Gray Scale Of Green	Green(0) / Dark	0	0	0	0	0	0	0	0	0	0	0	0	0	0	0	0	0	0	0	0	0	0	
	Green(1)	0	0	0	0	0	0	0	0	0	0	0	0	0	0	1	0	0	0	0	0	0	0	
	Green(2)	0	0	0	0	0	0	0	0	0	0	0	0	0	1	0	0	0	0	0	0	0	0	
	:	:	:	:	:	:	:	:	:	:	:	:	:	:	:	:	:	:	:	:	:	:	:	
	:	:	:	:	:	:	:	:	:	:	:	:	:	:	:	:	:	:	:	:	:	:	:	
	Green(253)	0	0	0	0	0	0	0	0	1	1	1	1	1	1	0	1	0	0	0	0	0	0	
	Green(254)	0	0	0	0	0	0	0	0	1	1	1	1	1	1	1	0	0	0	0	0	0	0	
	Green(255)	0	0	0	0	0	0	0	0	1	1	1	1	1	1	1	1	0	0	0	0	0	0	
Gray Scale Of Blue	Blue(0) / Dark	0	0	0	0	0	0	0	0	0	0	0	0	0	0	0	0	0	0	0	0	0	0	
	Blue(1)	0	0	0	0	0	0	0	0	0	0	0	0	0	0	0	0	0	0	0	0	0	1	
	Blue(2)	0	0	0	0	0	0	0	0	0	0	0	0	0	0	0	0	0	0	0	0	0	1	
	:	:	:	:	:	:	:	:	:	:	:	:	:	:	:	:	:	:	:	:	:	:	:	
	:	:	:	:	:	:	:	:	:	:	:	:	:	:	:	:	:	:	:	:	:	:	:	
	Blue(253)	0	0	0	0	0	0	0	0	0	0	0	0	0	0	0	0	1	1	1	1	1	0	
	Blue(254)	0	0	0	0	0	0	0	0	0	0	0	0	0	0	0	0	1	1	1	1	1	0	
	Blue(255)	0	0	0	0	0	0	0	0	0	0	0	0	0	0	0	0	1	1	1	1	1	1	

Note (1) 0: Low Level Voltage, 1: High Level Voltage

5.5 BLOCK DIAGRAM OF INTERFACE

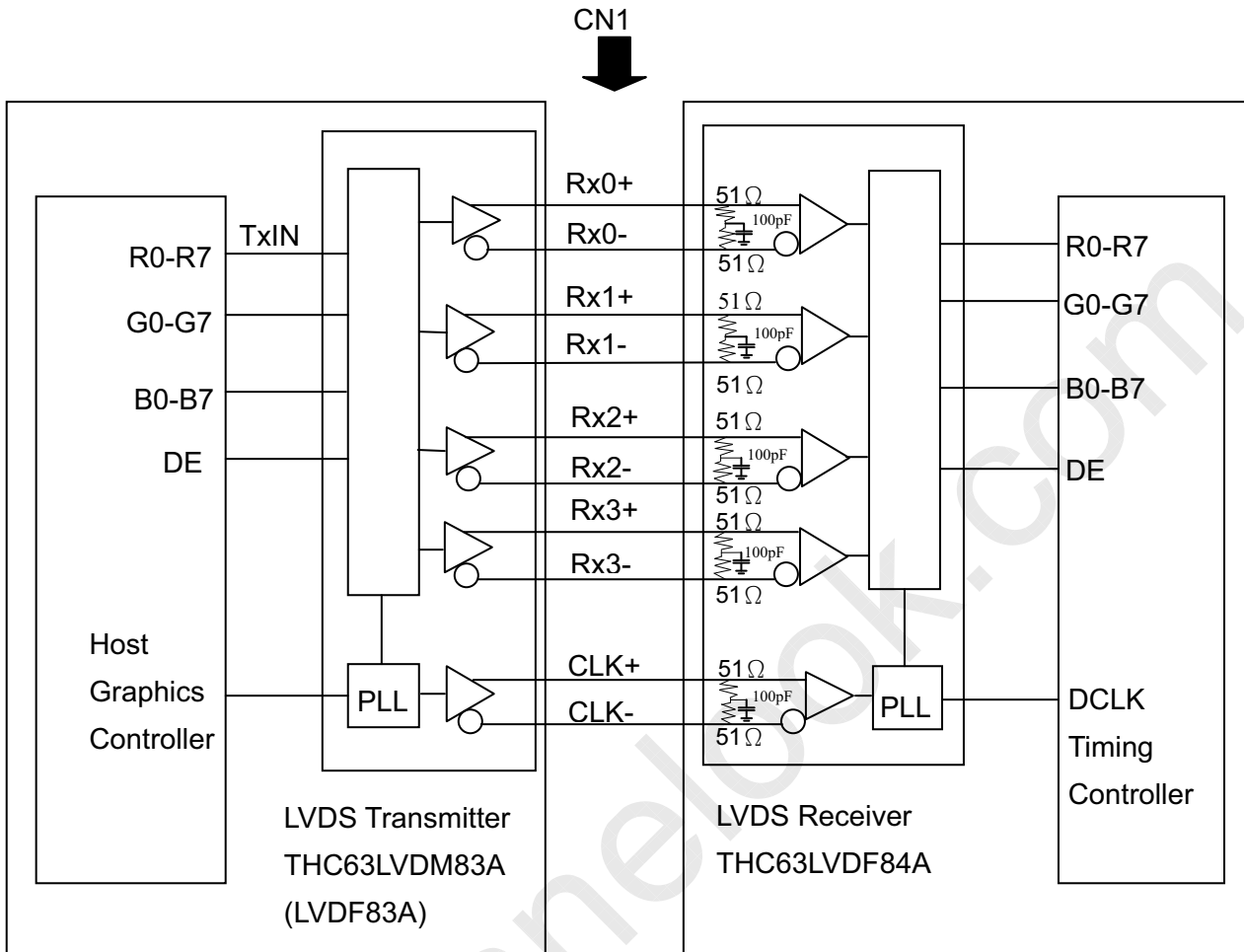

R0~R7 : Pixel R Data ,
 G0~G7 : Pixel G Data ,
 B0~B7 : Pixel B Data ,
 DE : Data enable signal
 DCLK : Data clock signal

Note (1) The system must have the transmitter to drive the module.

Note (2) LVDS cable impedance shall be 50 ohms per signal line or about 100 ohms per twist-pair line when it is used differentially.

6. INTERFACE TIMING

6.1 INPUT SIGNAL TIMING SPECIFICATIONS

The input signal timing specifications are shown as the following table and timing diagram.

Signal	Item	Symbol	Min.	Typ.	Max.	Unit	Note
LVDS Receiver Clock	Frequency	F_{clkin} (=1/TC)	60	76	82	MHz	
	Input cycle to cycle jitter	T_{rcI}	—	—	200	ps	(3)
	Spread spectrum	$F_{\text{clkin_mod}}$	$F_{\text{clkin}}-2\%$	—	$F_{\text{clkin}}+2\%$	MHz	(4)
	Spread spectrum	F_{SSM}			200	KHz	
LVDS Receiver Data	Setup Time	T_{Ivsu}	600	-	-	ps	(5)
	Hold Time	T_{Ivhd}	600	-	-	ps	
Vertical Active Display Term	Frame Rate	F_{r}	47	50	53	Hz	
			57	60	63		
	Total	T_{v}	778	806	888	Th	$T_{\text{v}}=T_{\text{vd}}+T_{\text{vb}}$
	Display	T_{vd}	768	768	768	Th	-
	Blank	T_{vb}	10	38	120	Th	-
Horizontal Active Display Term	Total	T_{h}	1442	1560	1936	T_{c}	$T_{\text{h}}=T_{\text{hd}}+T_{\text{hb}}$
	Display	T_{hd}	1366	1366	1366	T_{c}	-
	Blank	T_{hb}	76	194	570	T_{c}	-

Note (1) Since this module is operated in DE only mode, Hsync and Vsync input signals should be set to low logic level. Otherwise, this module would operate abnormally.

(2) Please refer to 5.1 for detail information.

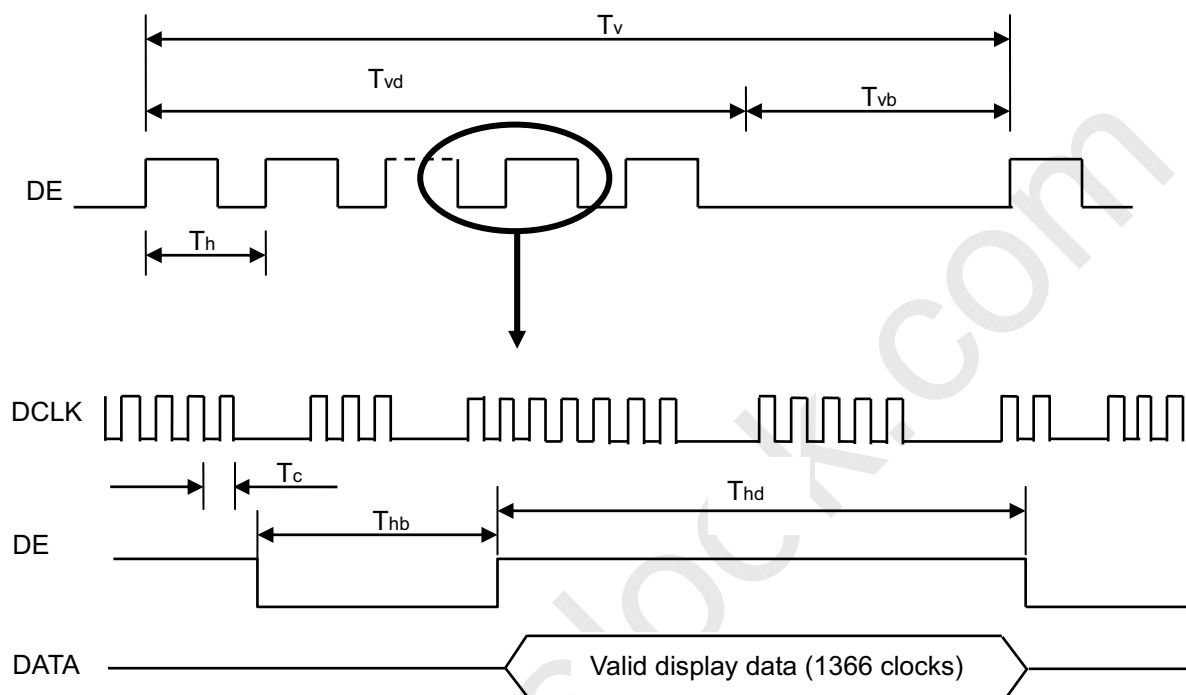
INPUT SIGNAL TIMING DIAGRAM

Note (3) The input clock cycle-to-cycle jitter is defined as below figures. $Trcl = |T_1 - T_1|$

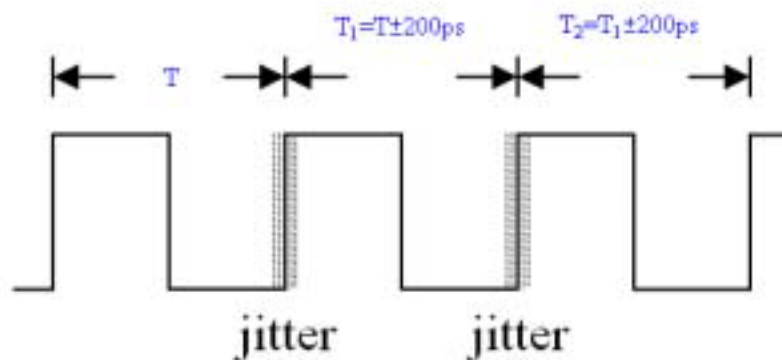

Note (4) The SSCG (Spread spectrum clock generator) is defined as below figures.

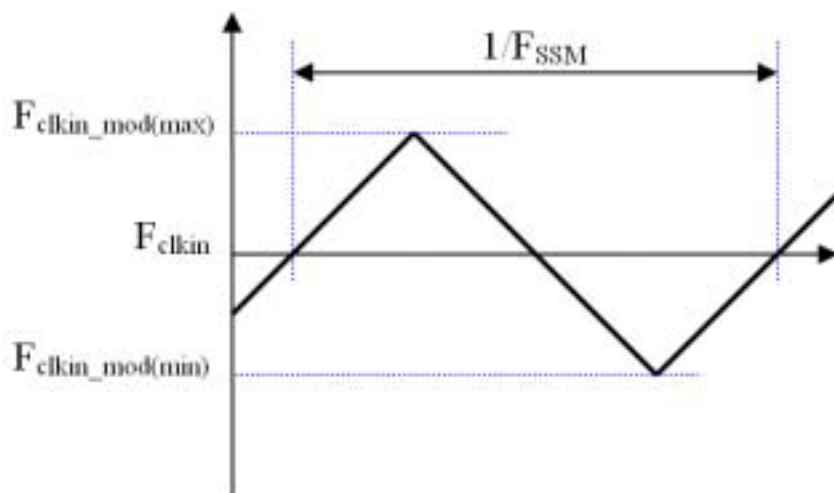

Note (5) The LVDS timing diagram and setup/hold time is defined and showing as the following figures.

LVDS RECEIVER INTERFACE TIMING DIAGRAM

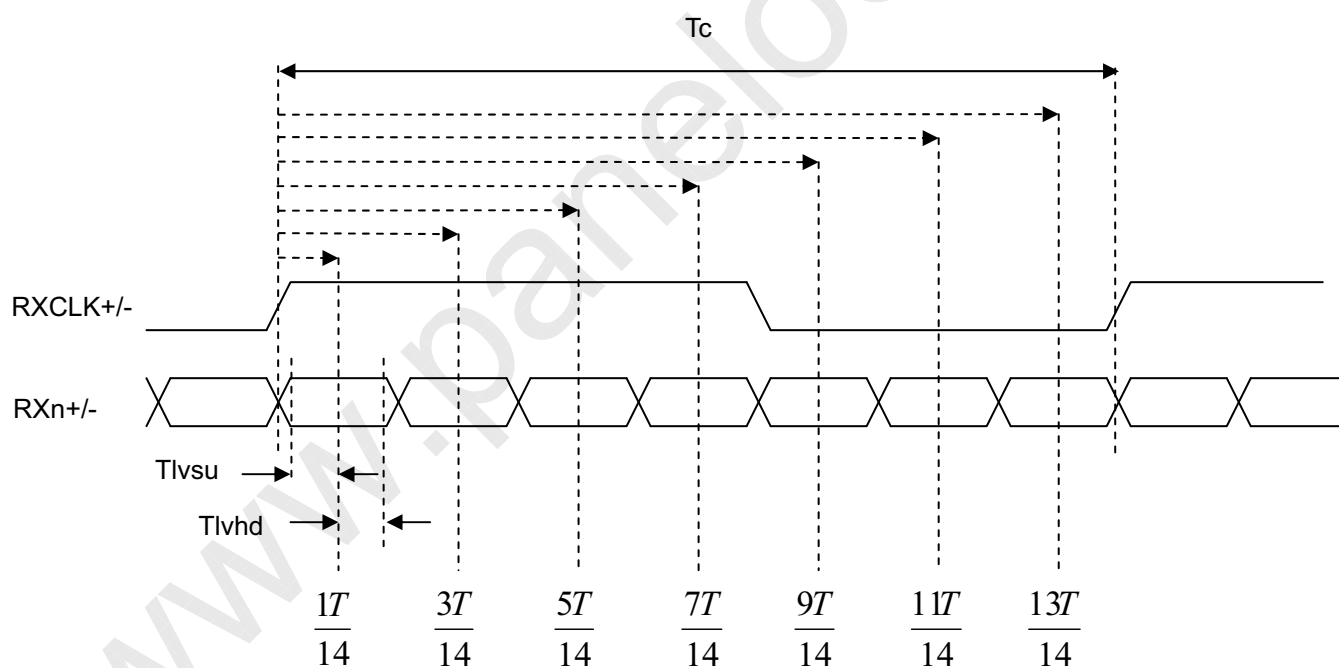

6.2 POWER ON/OFF SEQUENCE

($T_a = 25 \pm 2 \text{ }^\circ\text{C}$)

To prevent a latch-up or DC operation of LCD module, the power on/off sequence should be as the diagram below.

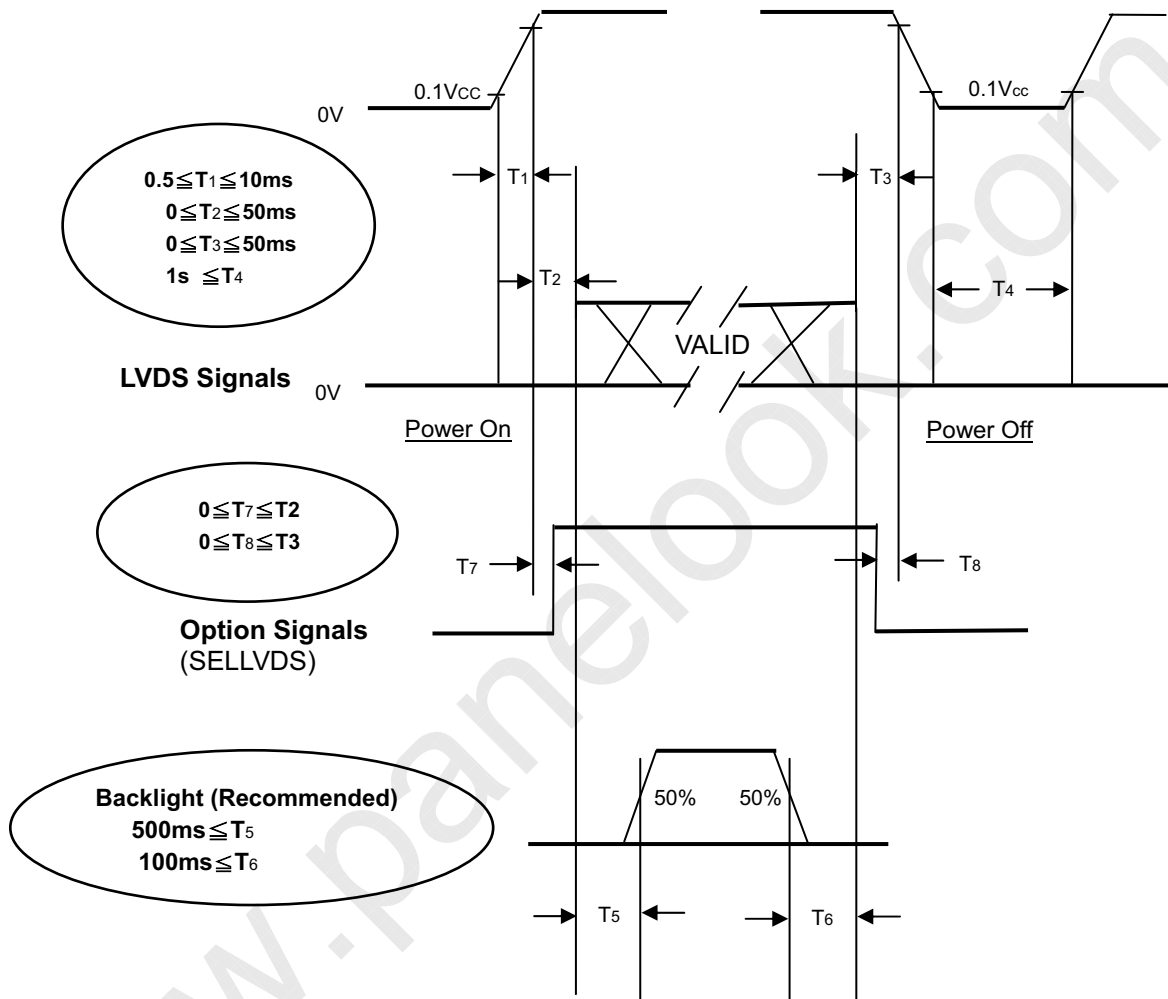

Power ON/OFF Sequence

Note (1) The supply voltage of the external system for the module input should follow the definition of Vcc.

Note (2) Apply the lamp voltage within the LCD operation range. When the backlight turns on before the LCD operation or the LCD turns off before the backlight turns off, the display may momentarily become abnormal screen.

Note (3) In case of Vcc is in off level, please keep the level of input signals on the low or high impedance. If $T_2 < 0$, that maybe cause electrical overstress failure.

Note (4) T4 should be measured after the module has been fully discharged between power off and on period.

Note (5) Interface signal shall not be kept at high impedance when the power is on.

7. OPTICAL CHARACTERISTICS

7.1 TEST CONDITIONS

Item	Symbol	Value	Unit
Ambient Temperature	Ta	25±2	°C
Ambient Humidity	Ha	50±10	%RH
Supply Voltage	Vcc	5.0	V
Input Signal	According to typical value in "3. ELECTRICAL CHARACTERISTICS"		
Inverter Current	IL	4.5 ± 0.5	mA
Inverter Driving Frequency	FL	41 ± 3	KHz

7.2 OPTICAL CHARACTERISTICS

Item	Symbol	Condition	Min.	Typ.	Max.	Unit	Note	
Contrast Ratio	CR	$\theta_x=0^\circ, \theta_y=0^\circ$ Viewing Angle at Normal Direction	600	1000		-	(2)	
Response Time	T _R			1.3	2.2	ms	(3)	
	T _F			3.7	5.8			
Center Luminance of White	L _C			300	400			(4)
White Variation	δW					1.3	-	(7)
Cross Talk	CT					4	%	(5)
Color Chromaticity	Red		R _x	Typ. -0.03	0.644	Typ. +0.03	-	(6)
			R _y		0.331		-	
	Green		G _x		0.273		-	
			G _y		0.588		-	
	Blue	B _x	0.151		-			
		B _y	0.061		-			
	White	W _x	0.285		-			
		W _y	0.293		-			
Color Gamut	CG		72		%	NTSC Ratio		
Viewing Angle	Horizontal	θ_{x+}	75	85	Deg.	(1)		
		θ_{x-}	75	85				
	Vertical	θ_{y+}	70	80				
		θ_{y-}	70	80				

Note (1) Definition of Viewing Angle (θ_x, θ_y):

Viewing angles are measured by Autronic Conoscope Cono-80

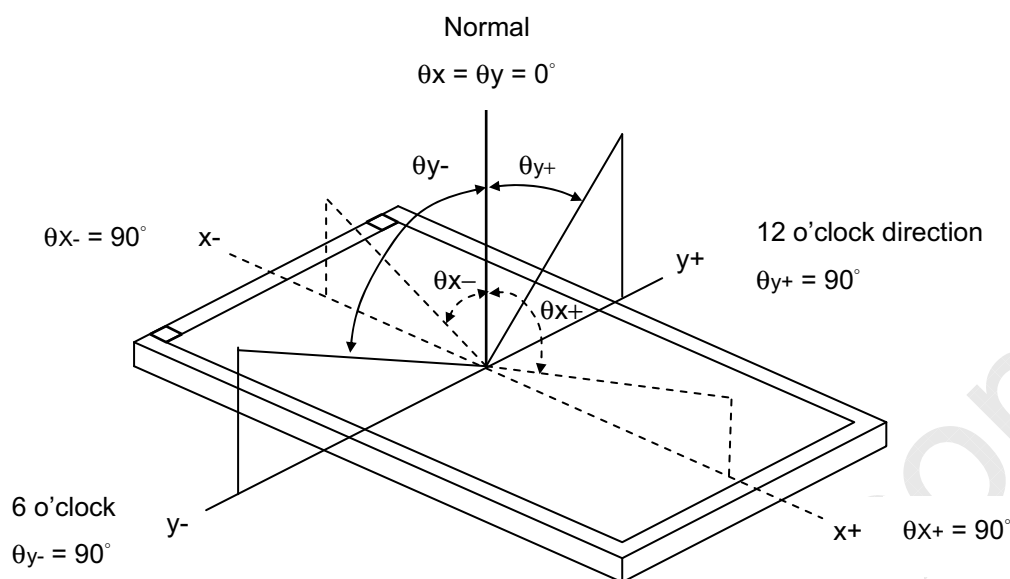

Note (2) Definition of Contrast Ratio (CR):

The contrast ratio can be calculated by the following expression.

$$\text{Contrast Ratio (CR)} = L_{255} / L_0$$

L₂₅₅: Luminance of gray level 255

L₀: Luminance of gray level 0

$$\text{CR} = \text{CR} (5),$$

CR (X) is corresponding to the Contrast Ratio of the point X at the figure in Note (7).

Note (3) Definition of Response Time (T_R , T_F):

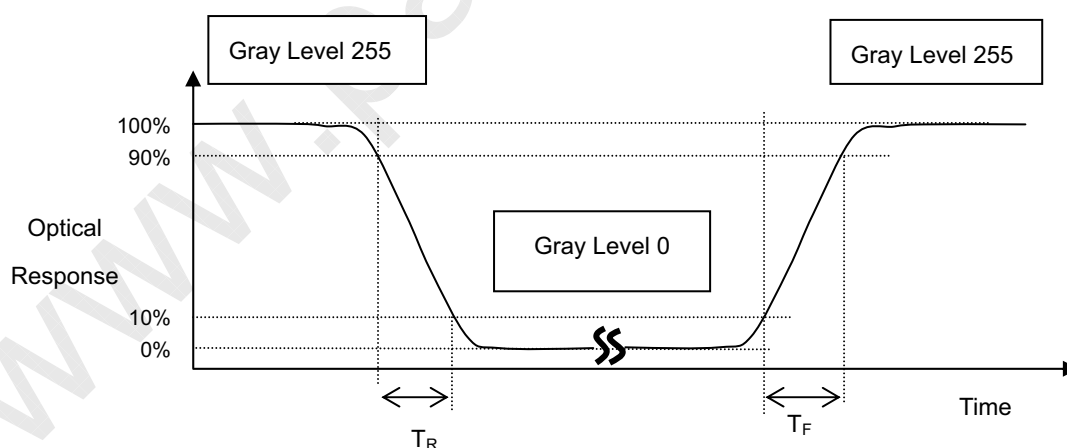

Note (4) Definition of Luminance of White (L_C):

Measure the luminance of gray level 255 at center point and 5 points

$$L_C = L (5)$$

L (X) is corresponding to the luminance of the point X at the figure in Note (7).

Note (5) Definition of Cross Talk (CT):

$$CT = |Y_B - Y_A| / Y_A \times 100 (\%)$$

Where:

Y_A = Luminance of measured location without gray level 0 pattern (cd/m^2)

Y_B = Luminance of measured location with gray level 0 pattern (cd/m^2)

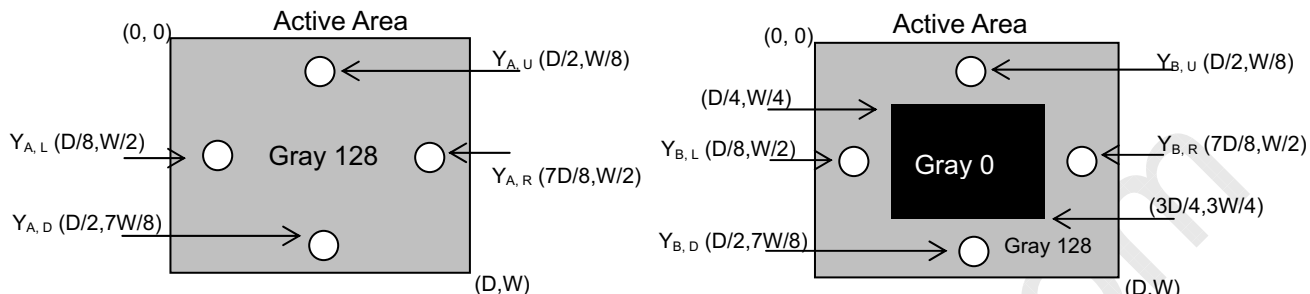

Note (6) Measurement Setup:

The LCD module should be stabilized at given temperature for 1 hour to avoid abrupt temperature change during measuring. In order to stabilize the luminance, the measurement should be executed after lighting Backlight for 1 hour in a windless room.

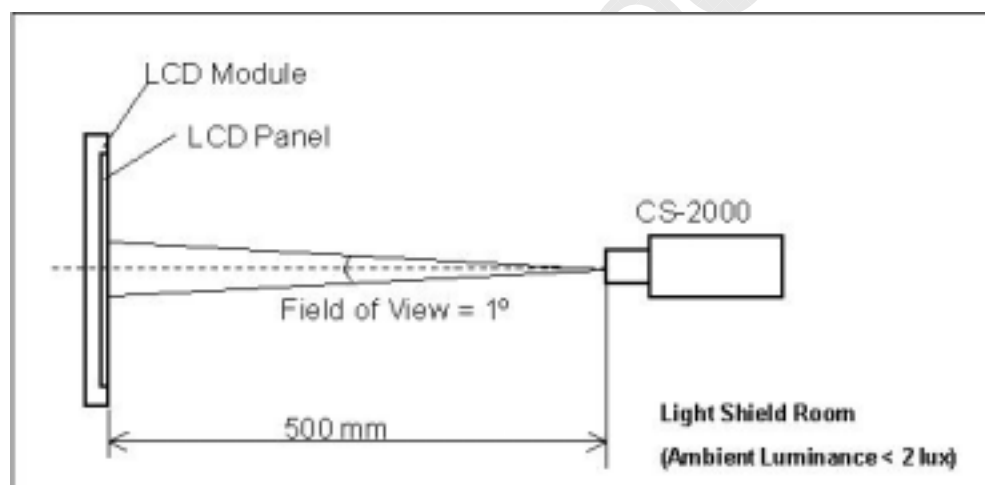

Note (7) Definition of White Variation (δW):

Measure the luminance of gray level 255 at 5 points

$$\delta W = \text{Maximum} [L(1), L(2), L(3), L(4), L(5)] / \text{Minimum} [L(1), L(2), L(3), L(4), L(5)]$$

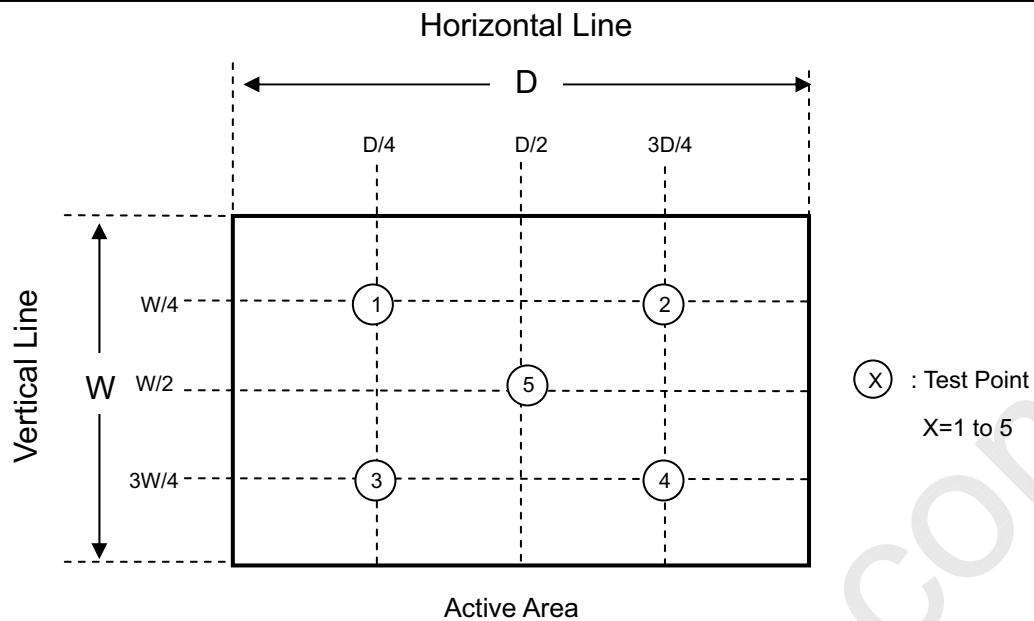

8. DEFINITION OF LABELS

8.1 CMO MODULE LABEL

The barcode nameplate is pasted on each module as illustration, and its definitions are as following explanation.

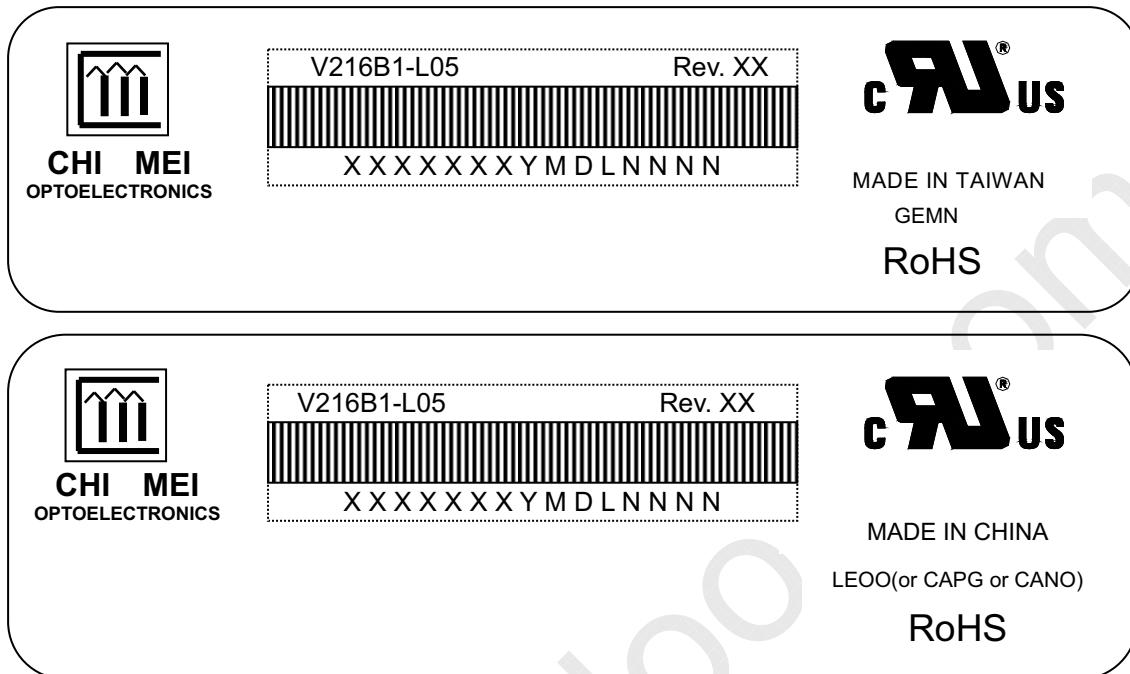

- (a) Model Name: V216B1-L05
- (b) Revision: Rev. XX, for example: A0, A1... B1, B2... or C1, C2...etc.
- (c) Serial ID: XXXXXXYYMDLNNNN

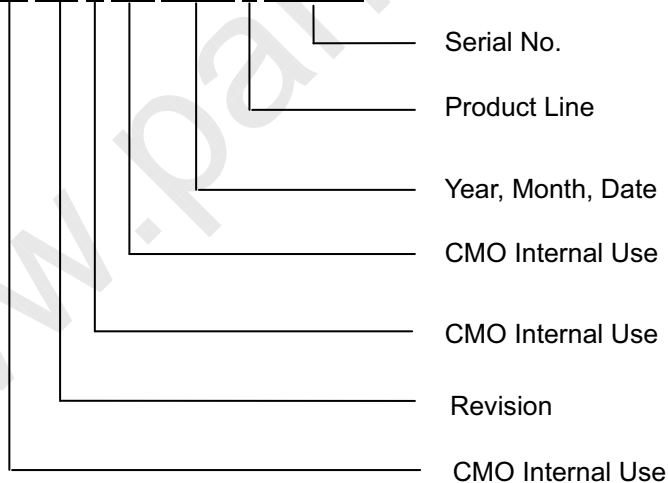

Serial ID includes the information as below:

- (a) Manufactured Date: Year: 2001=1, 2002=2, 2003=3, 2004=4....2010=0,2011=1,2012=2....
Month: 1~9, A~C, for Jan. ~ Dec.
Day: 1~9, A~Y, for 1st to 31st, exclude I ,O, and U.
- (b) Revision Code: Cover all the change
- (c) Serial No.: Manufacturing sequence of product
- (d) Product Line: 1 -> Line1, 2 -> Line 2, ...etc.

9. PACKAGING

9.1 PACKING SPECIFICATIONS

- (1) 13 LCD TV modules / 1 Box
- (2) Box dimensions: 563(L) X 417 (W) X 375 (H) mm
- (3) Weight: approximately 33Kg (13 modules per box)

9.2 PACKING METHOD

Figures 9-1 and 9-2 are the packing method

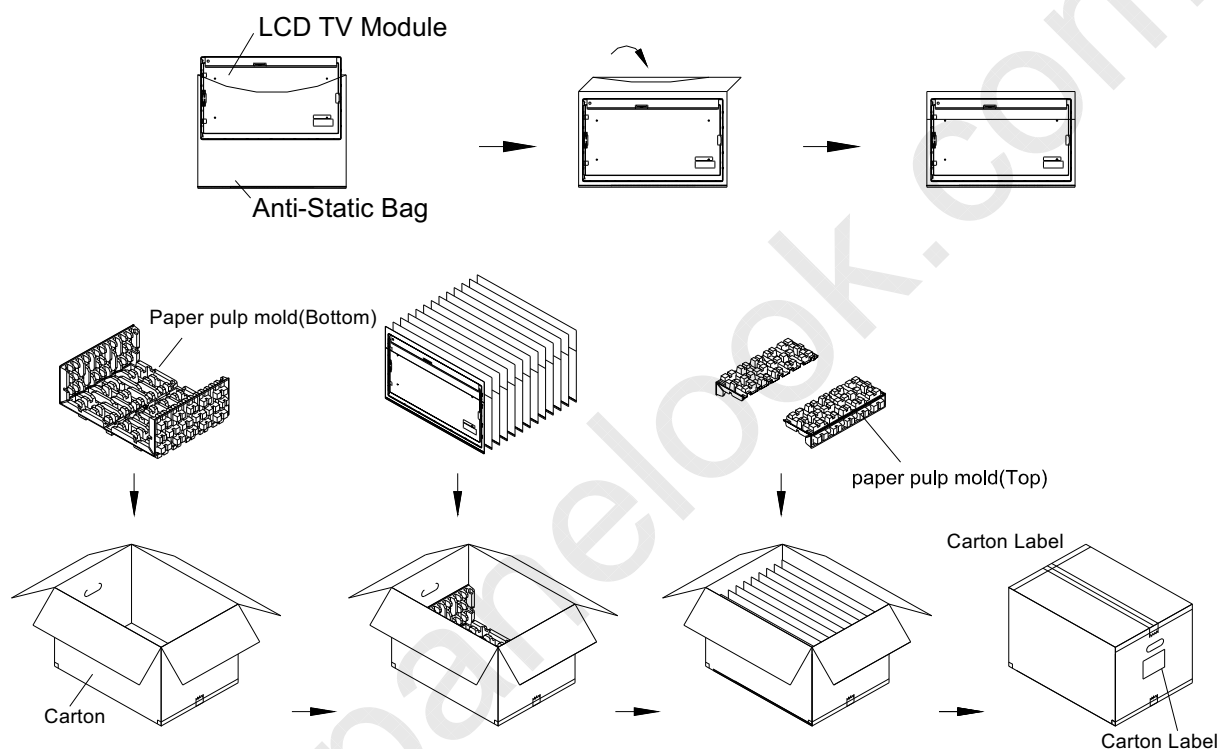

Figure.9-1 Packing Method

Sea / Land Transportation
(40ft HQ Container)
Pallet Stack:L850*W1150*H2530mm

Sea / Land Transportation
(40ft Container)
Pallet Stack:L850*W1150*H2155mm

Air Transportation
Pallet Stack:L850*W1150*H1265mm

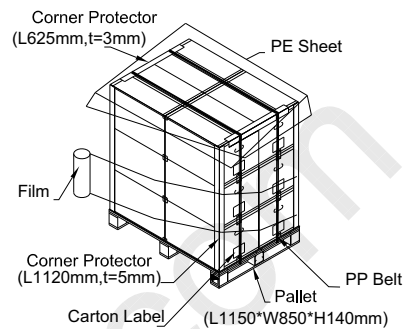
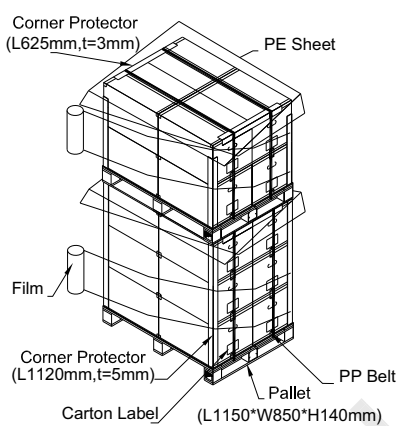
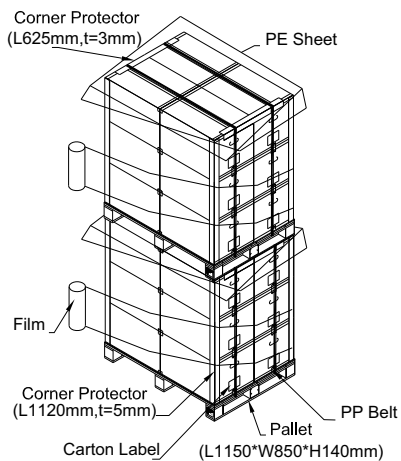

Figure.9-2 packing method

10. PRECAUTIONS

10.1 ASSEMBLY AND HANDLING PRECAUTIONS

- (1) Do not apply rough force such as bending or twisting to the module during assembly.
- (2) It is recommended to assemble or to install a module into the user's system in clean working areas.
The dust and oil may cause electrical short or worsen the polarizer.
- (3) Do not apply pressure or impulse to the module to prevent the damage of LCD panel and backlight.
- (4) Always follow the correct power-on sequence when the LCD module is turned on. This can prevent the damage and latch-up of the CMOS LSI chips.
- (5) Do not plug in or pull out the I/F connector while the module is in operation.
- (6) Do not disassemble the module.
- (7) Use a soft dry cloth without chemicals for cleaning, because the surface of polarizer is very soft and easily scratched.
- (8) Moisture can easily penetrate into LCD module and may cause the damage during operation.
- (9) High temperature or humidity may deteriorate the performance of LCD module. Please store LCD modules in the specified storage conditions.
- (10) When ambient temperature is lower than 10°C, the display quality might be reduced. For example, the response time will become slow, and the starting voltage of CCFL will be higher than that of room temperature.

10.2 SAFETY PRECAUTIONS

- (1) The startup voltage of a backlight is over 1000 Volts. It may cause an electrical shock while assembling with the inverter. Do not disassemble the module or insert anything into the backlight unit.
- (2) If the liquid crystal material leaks from the panel, it should be kept away from the eyes or mouth. In case of contact with hands, skin or clothes, it has to be washed away thoroughly with soap.
- (3) After the module's end of life, it is not harmful in case of normal operation and storage.

10.3 SAFETY STANDARDS

The LCD module should be certified with safety regulations as follows:

- (1) UL60950-1 or updated standard.
- (2) IEC60950-1 or updated standard.
- (3) UL60065 or updated standard.
- (4) IEC60065 or updated standard.

11. MECHANICAL CHARACTERISTIC

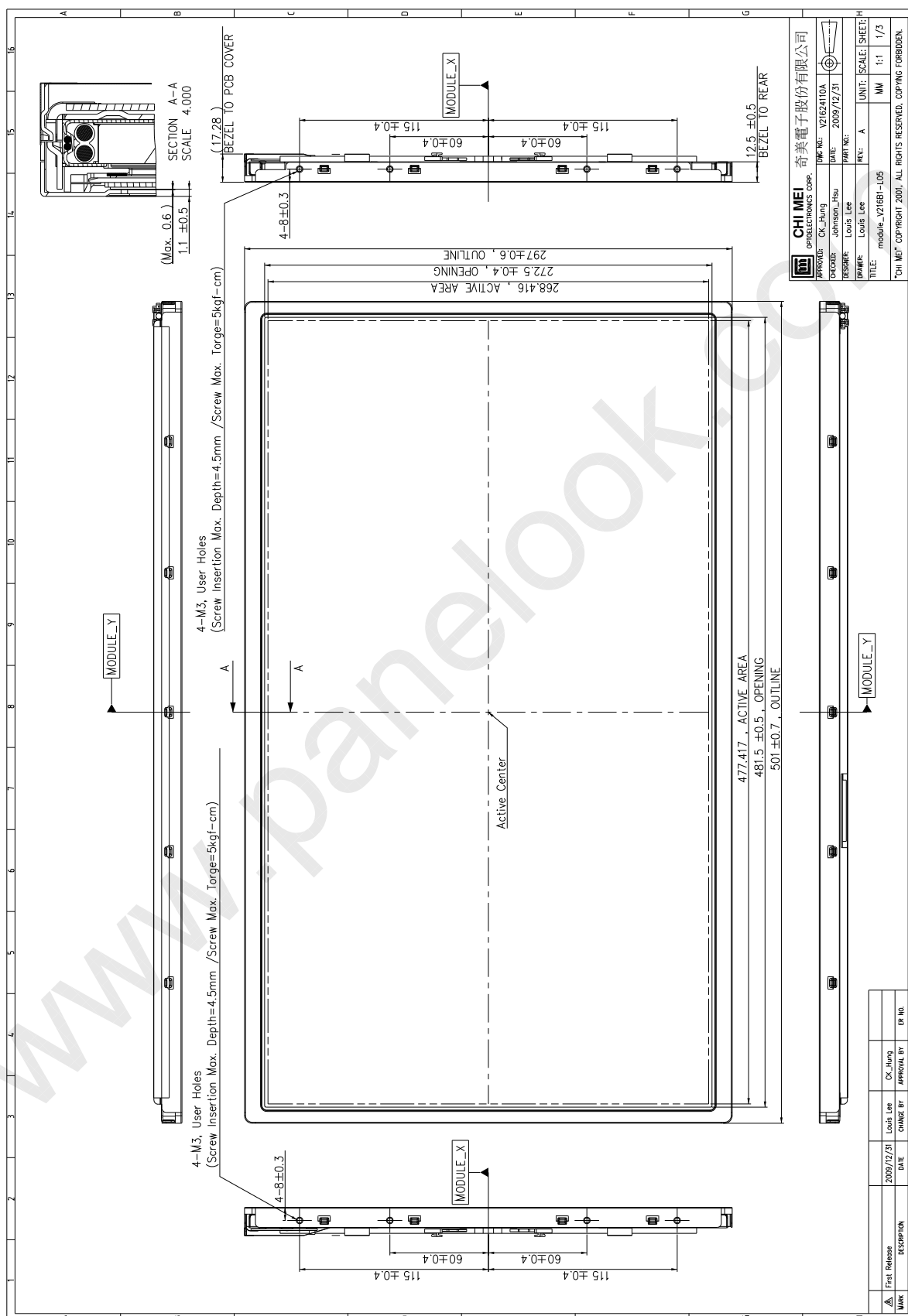



Issued Date: Feb. 5, 2010
Model No.: V216B1 - L05

Approval

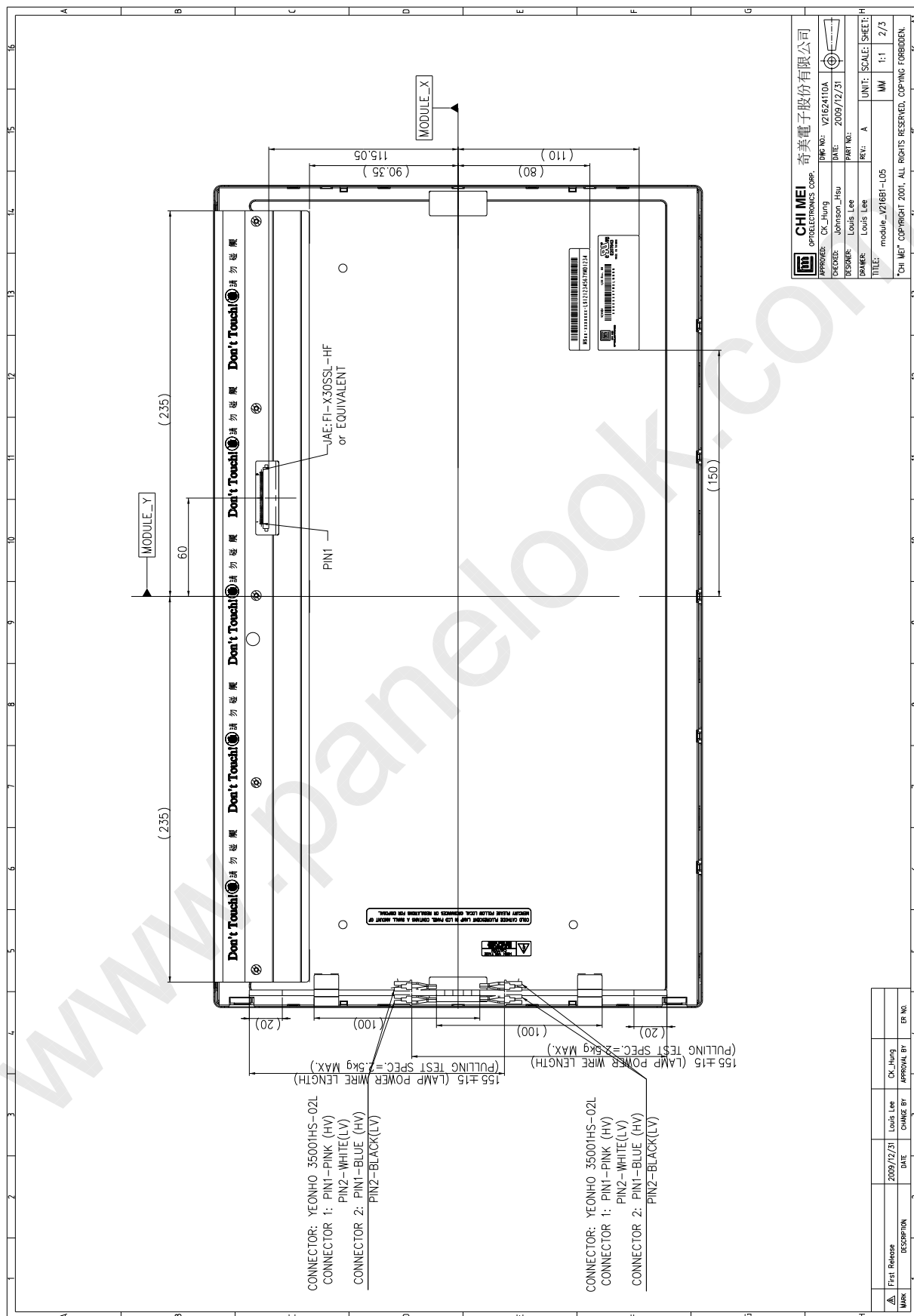

CHI MEI 奇美電子股份有限公司 OPTOELECTRONICS CORP.	
APPROVED: CK_Hung	CHK No.: V216B110A
CHECKED: Johnson_Hsu	DATE: 2009/12/31
DESIGNER: Louis Lee	PART No.:
DRAWER: Louis Lee	REV: A
TITLE: module_V216B1-L05	
UNIT: MM	SCALE: SHEET: 2/3
CHI MEI COPYRIGHT 2001. ALL RIGHTS RESERVED. COPYING FORBIDDEN.	

MARK	DESCRIPTION	DATE	CHANGE BY	APPROVAL BY	DR. NO.
Δ	First Release	2009/12/31	Louis Lee	CK_Hung	



Issued Date: Feb. 5, 2010
Model No.: V216B1 - L05

Approval

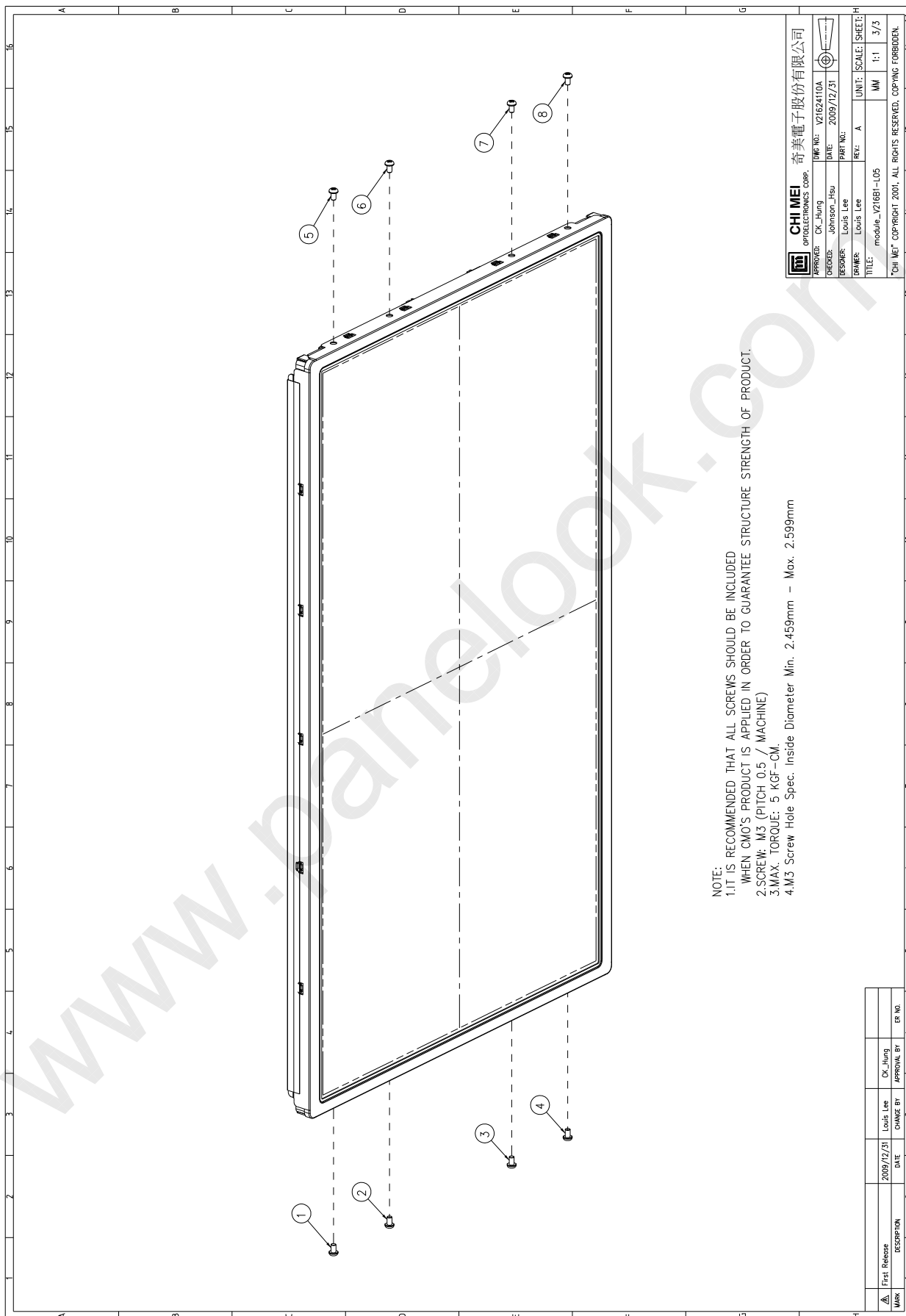

NOTE:
 1. IT IS RECOMMENDED THAT ALL SCREWS SHOULD BE INCLUDED WHEN CMO'S PRODUCT IS APPLIED IN ORDER TO GUARANTEE STRUCTURE STRENGTH OF PRODUCT.
 2. SCREW: M3 (PITCH 0.5 / MACHINE)
 3. MAX. TORQUE: 5 KGF-CM
 4. M3 Screw Hole Spec. Inside Diameter Min. 2.459mm - Max. 2.599mm

CHI MEI OPTOELECTRONICS CORP. 奇美電子股份有限公司	
APPROVE: CK_Hung	DMG No: V2162410A
DESIGNER: Johnson_Hsu	DATE: 2009/12/31
DRAWER: Louis Lee	PART NO:
REV: A	UNIT: SCALE: SHEET: H
TITLE: module_V216B1-L05	MM 1:1 3/3
CHI MEI COPYRIGHT 2001. ALL RIGHTS RESERVED. COPYING FORBIDDEN.	

First Release	2009/12/31	Louis Lee	CK_Hung
DESCRIPTION	DATE	CHANGE BY	APPROVAL BY
MARK			ER NO.