

- Tentative Specification  
 Preliminary Specification  
 Approval Specification

**MODEL NO.: V216B1**  
**SUFFIX: P14**

<b>Customer:</b>	
<b>APPROVED BY</b>	<b>SIGNATURE</b>
Name / Title _____	_____
<b>Note</b>	
Please return 1 copy for your confirmation with your signature and comments.	

Approved By	Checked By	Prepared By
Chao-Chun Chung	Roger Huang	Carlos Lee

## CONTENTS

1. GENERAL DESCRIPTION .....	5
1.1 OVERVIEW .....	5
1.2 CHARACTERISTICS .....	5
1.3 MECHANICAL SPECIFICATIONS .....	5
2. ABSOLUTE MAXIMUM RATINGS .....	6
2.1 ABSOLUTE RATINGS OF ENVIRONMENT (BASED ON CMI MODULE V216B1-L04) .....	6
2.2 ABSOLUTE RATINGS OF ENVIRONMENT (OPEN CELL) .....	7
2.3 ELECTRICAL ABSOLUTE RATINGS .....	7
2.3.1 TFT LCD MODULE .....	7
3. ELECTRICAL CHARACTERISTICS .....	8
3.1 TFT LCD MODULE .....	8
4. BLOCK DIAGRAM OF INTERFACE .....	11
4.1 TFT LCD MODULE .....	11
5. INPUT TERMINAL PIN ASSIGNMENT .....	12
5.1 TFT LCD Module Input .....	12
5.2 LVDS INTERFACE .....	13
5.3 COLOR DATA INPUT ASSIGNMENT .....	14
6. INTERFACE TIMING .....	15
6.1 INPUT SIGNAL TIMING SPECIFICATIONS .....	15
6.2 POWER ON/OFF SEQUENCE .....	18
7. OPTICAL CHARACTERISTICS .....	19
7.1 TEST CONDITIONS .....	19
7.2 OPTICAL SPECIFICATIONS .....	20
8. DEFINITION OF LABELS .....	23
8.1 OPEN CELL LABEL .....	23
8.2 CARTON LABEL .....	23
9. PACKAGING .....	24
9.1 PACKAGING SPECIFICATIONS .....	24

9.2 PACKAGING METHOD .....	24
10. PRECAUTIONS.....	26
10.1 ASSEMBLY AND HANDLING PRECAUTIONS .....	26
10.2 SAFETY PRECAUTIONS .....	26
11. MECHANICAL CHARACTERISTIC .....	27



## REVISION HISTORY

Version	Date	Page(New)	Section	Description
Ver. 2.0	Jun 15, 2010	All	All	The specification was first issued.

## 1. GENERAL DESCRIPTION

### 1.1 OVERVIEW

V216B1- P14 is a 21.6-inch TFT LCD cell with driver ICs and a 30pin 1ch-LVDS interface. This module supports 1366 x 768 (16:9 wide screen) formats and can display 16.7M colors (6-bit + Hi-FRC colors). The backlight unit is not built in.

### 1.2 CHARACTERISTICS

CHARACTERISTICS ITEMS	SPECIFICATIONS
Screen Diagonal [in]	21.6
Pixels [lines]	1366 × 768
Active Area [mm]	477.417 × 268.416
Sub -Pixel Pitch [mm]	0.1165 (H) × 0.3495 (V)
Pixel Arrangement	RGB vertical stripe
Weight [g]	TYP. 593
Physical Size [mm]	488.917(W) x 279.916(H) x 1.83(D) Typ.
Display Mode	TN, Normally White
Contrast Ratio	800:1 Typ. (Typical value measured at CMI's module)
Glass thickness (Array/CF) [mm]	0.7 / 0.7
Viewing Angle (CR>10)	+85/-85(H), +80/-80(V) Typ. (Typical value measured at CMI's module)
Color Chromaticity	R=0.6883, 0.3115 G=0.3347, 0.5615 B=0.1974, 0.1237 W=0.3203, 0.3595 *Please refer to "color chromaticity" on chapter 7.2
Cell Transparency [%]	7.1%Typ. (Typical value measured at CMI's module)
Polarizer (CF side)	Anti-Glare coating (Haze 25%) 484.4(H) x 275.8(w), Hardness: 3H
Polarizer (TFT side)	484.4(H) x 275.8 (w)

### 1.3 MECHANICAL SPECIFICATIONS

Item	Min.	Typ.	Max.	Unit	Note
Weight	564	593	622	g	
I/F connector mounting position	The mounting inclination of the connector makes the screen center within ±0.5mm as the horizontal.				(1)

Note (1) Connector mounting position

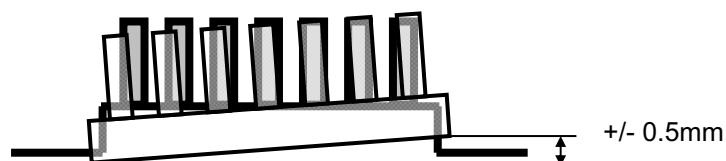

## 2. ABSOLUTE MAXIMUM RATINGS

### 2.1 ABSOLUTE RATINGS OF ENVIRONMENT (BASED ON CMI MODULE V216B1-L04)

Item	Symbol	Value		Unit	Note
		Min.	Max.		
Storage Temperature	T <sub>ST</sub>	-20	+60	°C	(1)
Operating Ambient Temperature	T <sub>OP</sub>	0	+50	°C	(1) (2)

Note (1) Temperature and relative humidity range is shown in the figure below.

- (a) 90 %RH Max. ( $T_a \leq 40$  °C).
- (b) Wet-bulb temperature should be 39 °C Max. ( $T_a > 40$  °C).
- (c) No condensation.

Note (2) The maximum operating temperature is based on the test condition that the surface temperature of display area is less than or equal to 65 °C with LCD module alone in a temperature controlled chamber. Thermal management should be considered in final product design to prevent the surface temperature of display area from being over 65 °C. The range of operating temperature may degrade in case of improper thermal management in final product design.

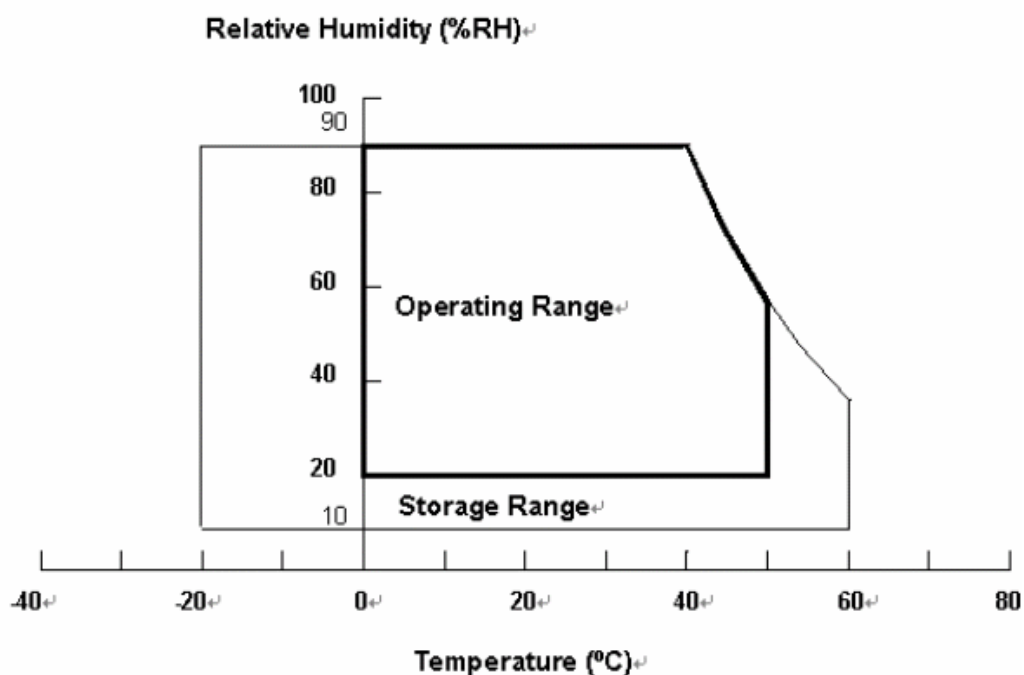

## 2.2 ABSOLUTE RATINGS OF ENVIRONMENT (OPEN CELL)

Storage Condition: With shipping package.

Storage temperature range: 25±5 °C

Storage humidity range: 50±10%RH

Shelf life: a month

## 2.3 ELECTRICAL ABSOLUTE RATINGS

### 2.3.1 TFT LCD MODULE

Item	Symbol	Value		Unit	Note
		Min.	Max.		
Power Supply Voltage	V <sub>CC</sub>	-0.3	6.0	V	(1)
Logic Input Voltage	V <sub>IN</sub>	-0.3	3.6	V	

Note (1) Permanent damage to the device may occur if maximum values are exceeded. Function operation should be restricted to the conditions described under Normal Operating Conditions.

## 3. ELECTRICAL CHARACTERISTICS

### 3.1 TFT LCD MODULE

(Ta = 25 ± 2 °C)

Parameter	Symbol	Value			Unit	Note	
		Min.	Typ.	Max.			
Power Supply Voltage	V <sub>CC</sub>	4.5	5.0	5.5	V	(1)	
Rush Current	I <sub>RUSH</sub>	—	—	3.0	A	(2)	
Power Supply Current	White	—	0.40	—	A	(3)	
	Black	—	0.53	0.61	A		
	Vertical Stripe	—	0.50	—	A		
LVDS interface	Differential Input High Threshold Voltage	V <sub>LVTH</sub>	+100	—	—	mV	(4)
	Differential Input Low Threshold Voltage	V <sub>LVTL</sub>	—	—	-100	mV	
	Common Input Voltage	V <sub>CM</sub>	1.0	1.2	1.4	V	
	Differential input voltage	V <sub>ID</sub>	200	—	600	mV	
	Terminating Resistor	R <sub>T</sub>	—	100	—	ohm	
CMOS interface	Input High Threshold Voltage	V <sub>IH</sub>	2.7	—	3.3	V	
	Input Low Threshold Voltage	V <sub>IL</sub>	0	—	0.7	V	

Note (1) The module should be always operated within the above ranges.

Note (2) Measurement condition:

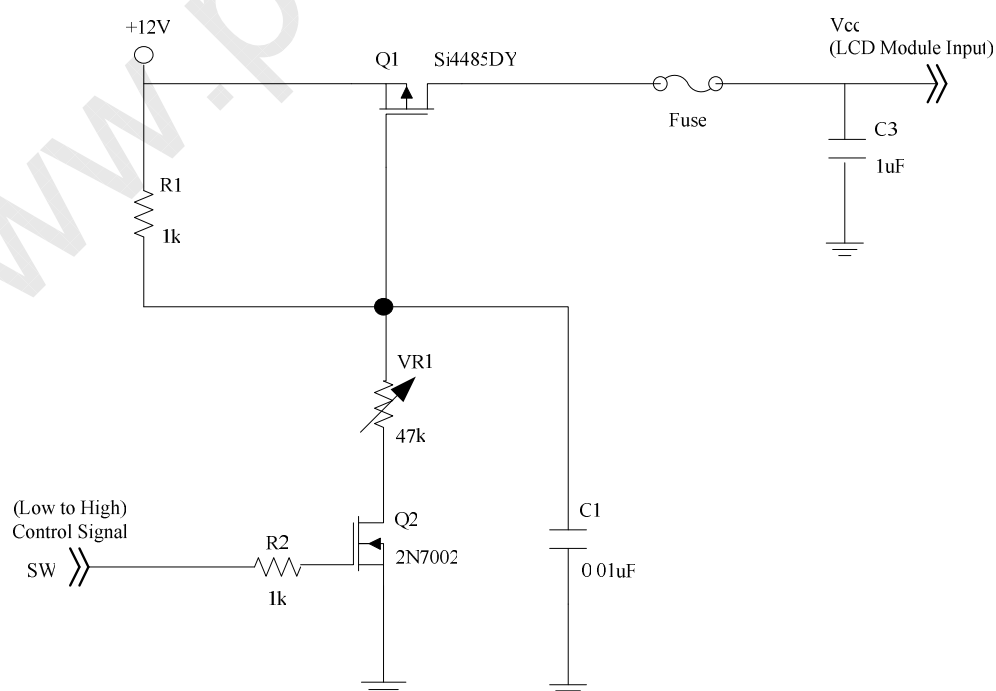

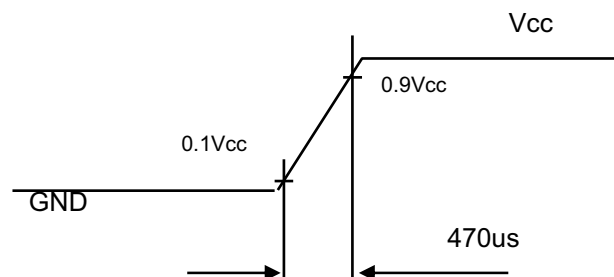

**Vcc rising time is 470us**

Note (3) The specified power supply current is under the conditions at  $V_{cc} = 5\text{ V}$ ,  $T_a = 25 \pm 2\text{ }^\circ\text{C}$ ,  $f_v = 60\text{ Hz}$ , whereas a power dissipation check pattern below is displayed.

a. White Pattern



Active Area

b. Black Pattern



Active Area

c. Horizontal Pattern

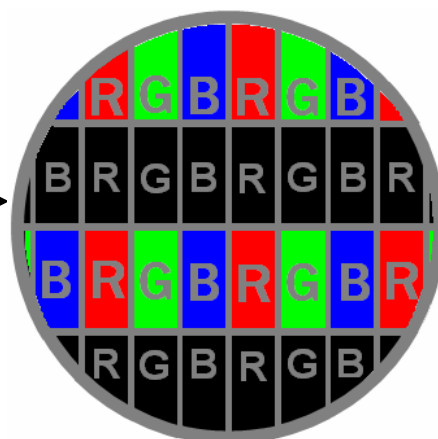
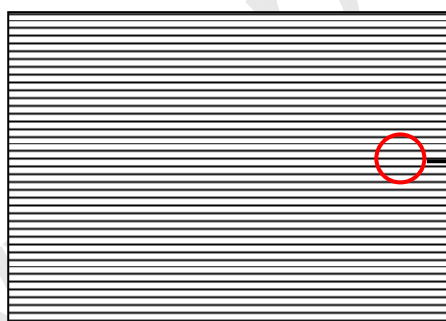

Note (4) The LVDS input characteristics are as follows:

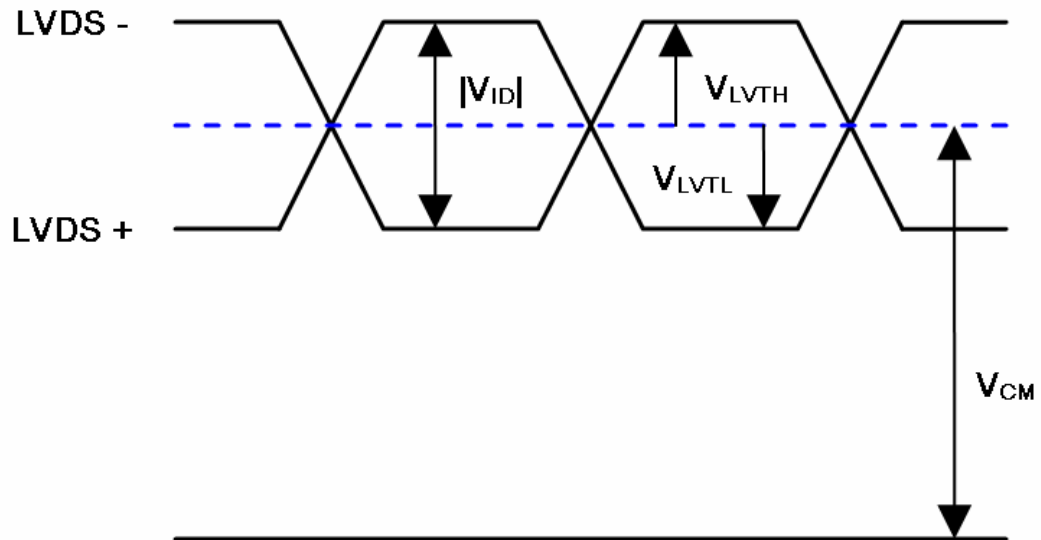

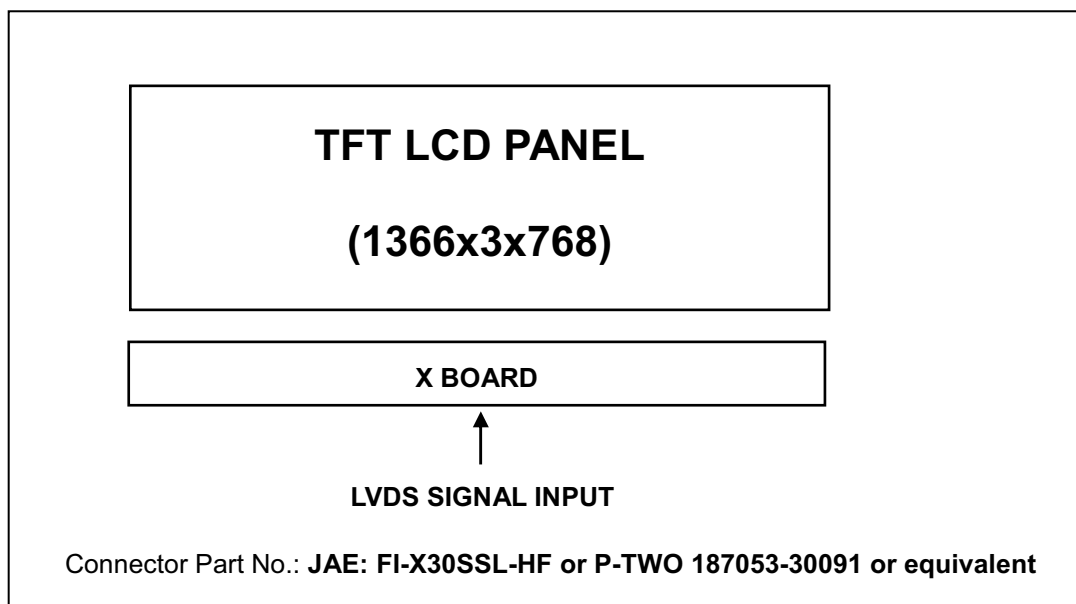
**4. BLOCK DIAGRAM OF INTERFACE****4.1 TFT LCD MODULE**

**5. INPUT TERMINAL PIN ASSIGNMENT**
**5.1 TFT LCD Module Input**

Pin No.	Symbol	Description	Note
1	NC	No connection	(2)
2	NC	No connection	(2)
3	NC	No connection	(2)
4	GND	Ground	
5	RX0-	Negative transmission data of pixel 0	
6	RX0+	Positive transmission data of pixel 0	
7	GND	Ground	
8	RX1-	Negative transmission data of pixel 1	
9	RX1+	Positive transmission data of pixel 1	
10	GND	Ground	
11	RX2-	Negative transmission data of pixel 2	
12	RX2+	Positive transmission data of pixel 2	
13	GND	Ground	
14	RXCLK-	Negative of clock	
15	RXCLK+	Positive of clock	
16	GND	Ground	
17	RX3-	Negative transmission data of pixel 3	
18	RX3+	Positive transmission data of pixel 3	
19	GND	Ground	
20	NC	No connection	(2)
21	SELLVDS	Select LVDS data format	(3)
22	NC	No connection	(2)
23	GND	Ground	
24	GND	Ground	
25	GND	Ground	
26	VCC	Power supply: +5V	
27	VCC	Power supply: +5V	
28	VCC	Power supply: +5V	
29	VCC	Power supply: +5V	
30	VCC	Power supply: +5V	

Note (1) Connector part no.: JAE FI-X30SSL-HF or P-TWO 187053-30091 or equivalent

LVDS connector pin order defined as follows

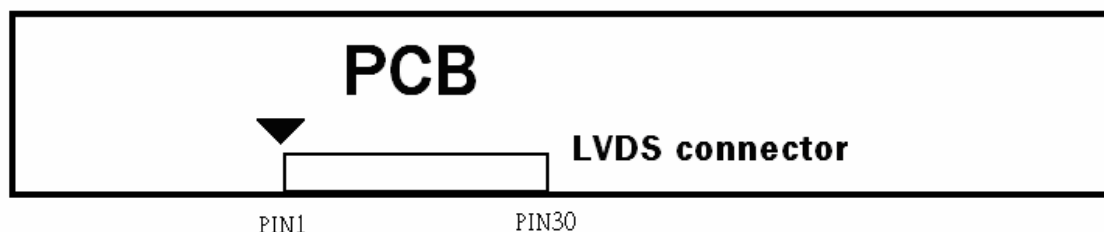

Note (2) Reserved for internal use. Please leave it open.

Note (3) High or OPEN: Normal, Ground: JEIDA LVDS format

Please refer to chapter 5.2 LVDS INTERFACE.

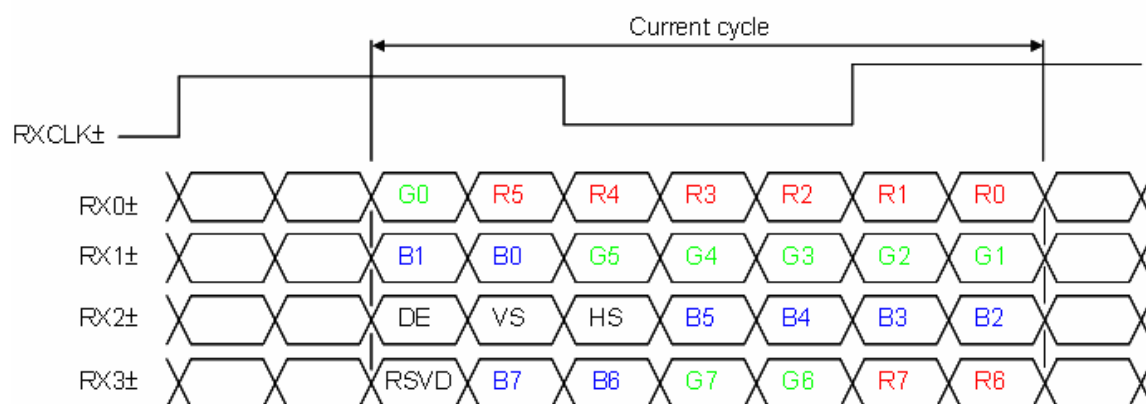
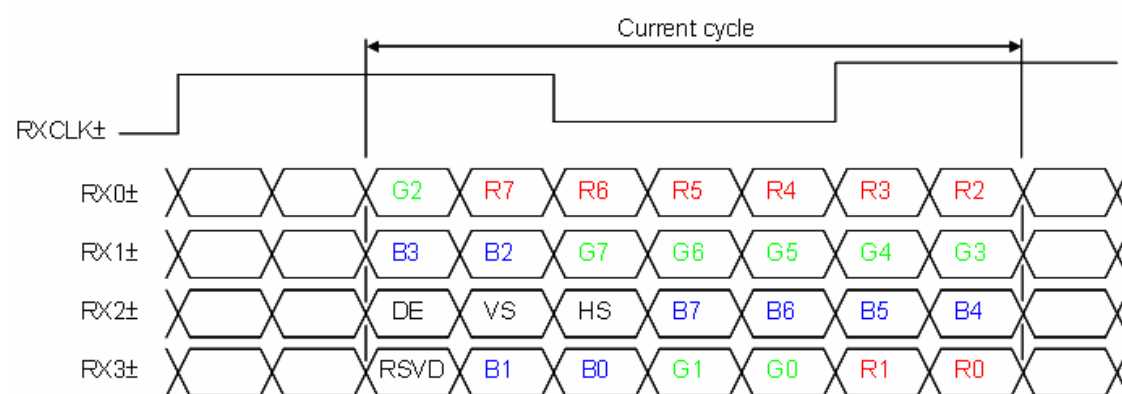
**5.2 LVDS INTERFACE**
**SELLVDS = H or Open (VESA)**

**SELLVDS = L (JEIDA)**

R0~R7: Pixel R Data (7; MSB, 0; LSB)

G0~G7: Pixel G Data (7; MSB, 0; LSB)

B0~B7: Pixel B Data (7; MSB, 0; LSB)

DE : Data enable signal

Notes (1) RSVD (reserved) pins on the transmitter shall be "H" or "L".

## 5.3 COLOR DATA INPUT ASSIGNMENT

The brightness of each primary color (red, green and blue) is based on the 8-bit gray scale data input for the color. The higher the binary input, the brighter the color. The table below provides the assignment of the color versus data input.

Color		Data Signal																						
		Red								Green								Blue						
		R7	R6	R5	R4	R3	R2	R1	R0	G7	G6	G5	G4	G3	G2	G1	G0	B7	B6	B5	B4	B3	B2	B1
Basic Colors	Black	0	0	0	0	0	0	0	0	0	0	0	0	0	0	0	0	0	0	0	0	0	0	0
	Red	1	1	1	1	1	1	1	1	0	0	0	0	0	0	0	0	0	0	0	0	0	0	0
	Green	0	0	0	0	0	0	0	0	1	1	1	1	1	1	1	1	0	0	0	0	0	0	0
	Blue	0	0	0	0	0	0	0	0	0	0	0	0	0	0	0	0	1	1	1	1	1	1	1
	Cyan	0	0	0	0	0	0	0	0	1	1	1	1	1	1	1	1	1	1	1	1	1	1	1
	Magenta	1	1	1	1	1	1	1	1	0	0	0	0	0	0	0	0	1	1	1	1	1	1	1
	Yellow	1	1	1	1	1	1	1	1	1	1	1	1	1	1	1	1	0	0	0	0	0	0	0
	White	1	1	1	1	1	1	1	1	1	1	1	1	1	1	1	1	1	1	1	1	1	1	1
Gray Scale Of Red	Red (0) / Dark	0	0	0	0	0	0	0	0	0	0	0	0	0	0	0	0	0	0	0	0	0	0	
	Red (1)	0	0	0	0	0	0	0	1	0	0	0	0	0	0	0	0	0	0	0	0	0	0	
	Red (2)	0	0	0	0	0	0	1	0	0	0	0	0	0	0	0	0	0	0	0	0	0	0	
	:	:	:	:	:	:	:	:	:	:	:	:	:	:	:	:	:	:	:	:	:	:	:	
	:	:	:	:	:	:	:	:	:	:	:	:	:	:	:	:	:	:	:	:	:	:	:	
	Red (253)	1	1	1	1	1	1	0	1	0	0	0	0	0	0	0	0	0	0	0	0	0	0	
	Red (254)	1	1	1	1	1	1	1	0	0	0	0	0	0	0	0	0	0	0	0	0	0	0	
	Red (255)	1	1	1	1	1	1	1	1	0	0	0	0	0	0	0	0	0	0	0	0	0	0	
Gray Scale Of Green	Green (0) / Dark	0	0	0	0	0	0	0	0	0	0	0	0	0	0	0	0	0	0	0	0	0	0	
	Green (1)	0	0	0	0	0	0	0	0	0	0	0	0	0	0	0	1	0	0	0	0	0	0	
	Green (2)	0	0	0	0	0	0	0	0	0	0	0	0	0	0	1	0	0	0	0	0	0	0	
	:	:	:	:	:	:	:	:	:	:	:	:	:	:	:	:	:	:	:	:	:	:	:	
	:	:	:	:	:	:	:	:	:	:	:	:	:	:	:	:	:	:	:	:	:	:	:	
	Green (253)	0	0	0	0	0	0	0	0	1	1	1	1	1	1	0	1	0	0	0	0	0	0	
	Green (254)	0	0	0	0	0	0	0	0	1	1	1	1	1	1	1	0	0	0	0	0	0	0	
	Green (255)	0	0	0	0	0	0	0	0	1	1	1	1	1	1	1	0	0	0	0	0	0	0	
Gray Scale Of Blue	Blue (0) / Dark	0	0	0	0	0	0	0	0	0	0	0	0	0	0	0	0	0	0	0	0	0	0	
	Blue (1)	0	0	0	0	0	0	0	0	0	0	0	0	0	0	0	0	0	0	0	0	0	1	
	Blue (2)	0	0	0	0	0	0	0	0	0	0	0	0	0	0	0	0	0	0	0	0	0	1	
	:	:	:	:	:	:	:	:	:	:	:	:	:	:	:	:	:	:	:	:	:	:	:	
	:	:	:	:	:	:	:	:	:	:	:	:	:	:	:	:	:	:	:	:	:	:	:	
	Blue (253)	0	0	0	0	0	0	0	0	0	0	0	0	0	0	0	0	1	1	1	1	1	0	
	Blue (254)	0	0	0	0	0	0	0	0	0	0	0	0	0	0	0	0	1	1	1	1	1	0	
	Blue (255)	0	0	0	0	0	0	0	0	0	0	0	0	0	0	0	0	1	1	1	1	1	1	

Note (1) 0: Low Level Voltage, 1: High Level Voltage

## 6. INTERFACE TIMING

### 6.1 INPUT SIGNAL TIMING SPECIFICATIONS

(Ta = 25 ± 2 °C)

The input signal timing specifications are shown as the following table and timing diagram.

Signal	Item	Symbol	Min.	Typ.	Max.	Unit	Note
LVDS Receiver Clock	Frequency	F <sub>clkkin</sub> (=1/TC)	60	76	82	MHz	
	Input cycle to cycle jitter	T <sub>rcj</sub>	—	—	200	ps	(3)
	Spread spectrum modulation range	F <sub>clkkin_mod</sub>	F <sub>clkkin</sub> -2%	—	F <sub>clkkin</sub> +2%	MHz	(4)
	Spread spectrum modulation frequency	F <sub>SSM</sub>	—	—	200	KHz	
LVDS Receiver Data	Setup Time	T <sub>lvsu</sub>	600	—	—	ps	(5)
	Hold Time	T <sub>lvhd</sub>	600	—	—	ps	
Vertical Active Display Term	Frame Rate	F <sub>r5</sub>	47	50	53	Hz	
		F <sub>r6</sub>	57	60	63	Hz	
	Total	T <sub>v</sub>	778	806	1050	Th	T <sub>v</sub> =T <sub>vd</sub> +T <sub>vb</sub>
	Display	T <sub>vd</sub>	768	768	768	Th	
	Blank	T <sub>vb</sub>	10	38	282	Th	
Horizontal Active Display Term	Total	T <sub>h</sub>	1442	1560	1936	T <sub>c</sub>	T <sub>h</sub> =T <sub>hd</sub> +T <sub>hb</sub>
	Display	T <sub>hd</sub>	1366	1366	1366	T <sub>c</sub>	
	Blank	T <sub>hb</sub>	76	194	570	T <sub>c</sub>	

“Enlarging V<sub>total</sub> from Max 888Th to 1050Th is OK, provided that both pixel clock & H<sub>total</sub> are within the specified range in the spec.”

Note (1) Please make sure the range of pixel clock has follow the below equation :

$$F_{clkkin}(\max) \geq F_{r6} \times T_v \times T_h$$

$$F_{r5} \times T_v \times T_h \geq F_{clkkin}(\min)$$

Note (2) This module is operated in DE only mode and please follow the input signal timing diagram below :

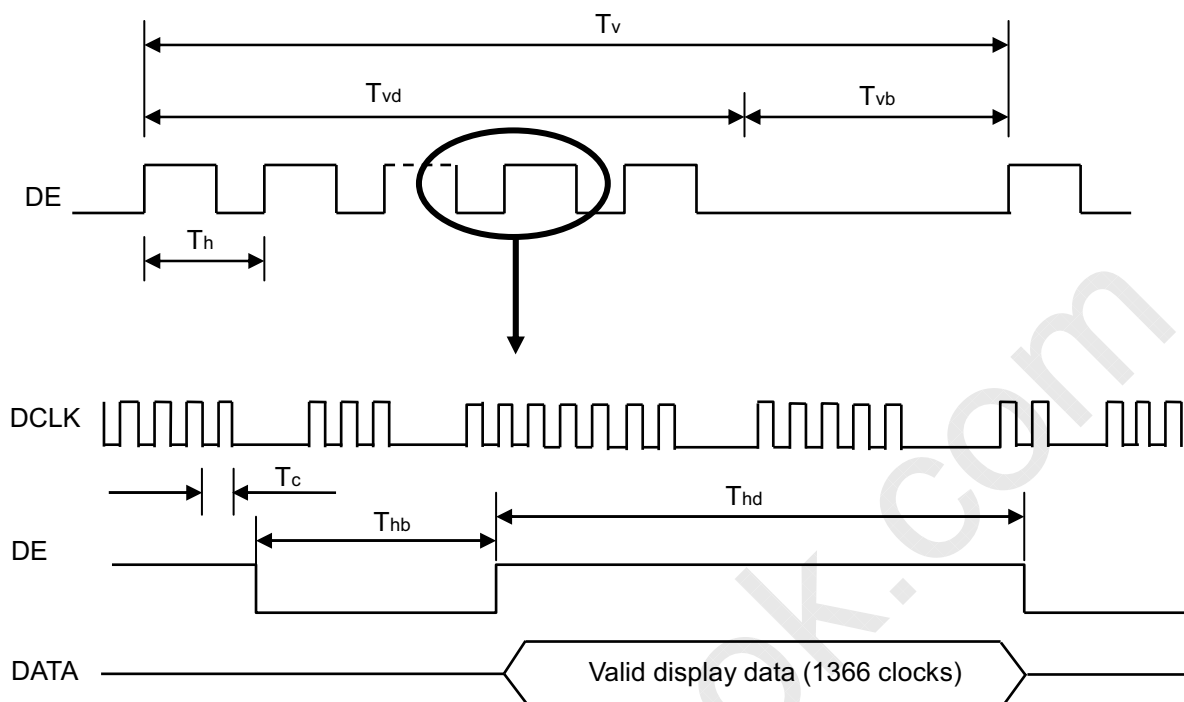
**INPUT SIGNAL TIMING DIAGRAM**

Note (3) The input clock cycle-to-cycle jitter is defined as below figures.  $Trcl = |T_1 - T_2|$

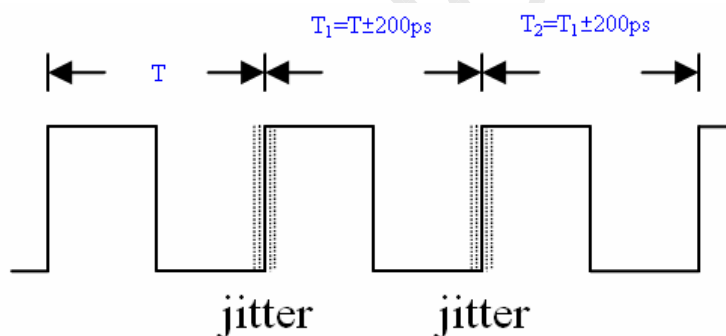

Note (4) The SSCG (Spread spectrum clock generator) is defined as below figures.

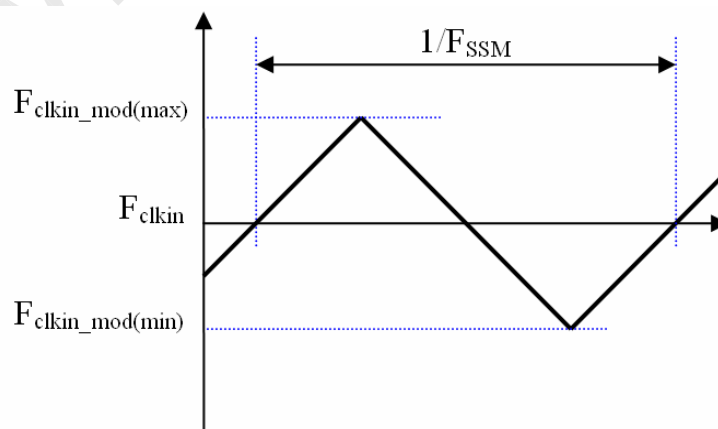

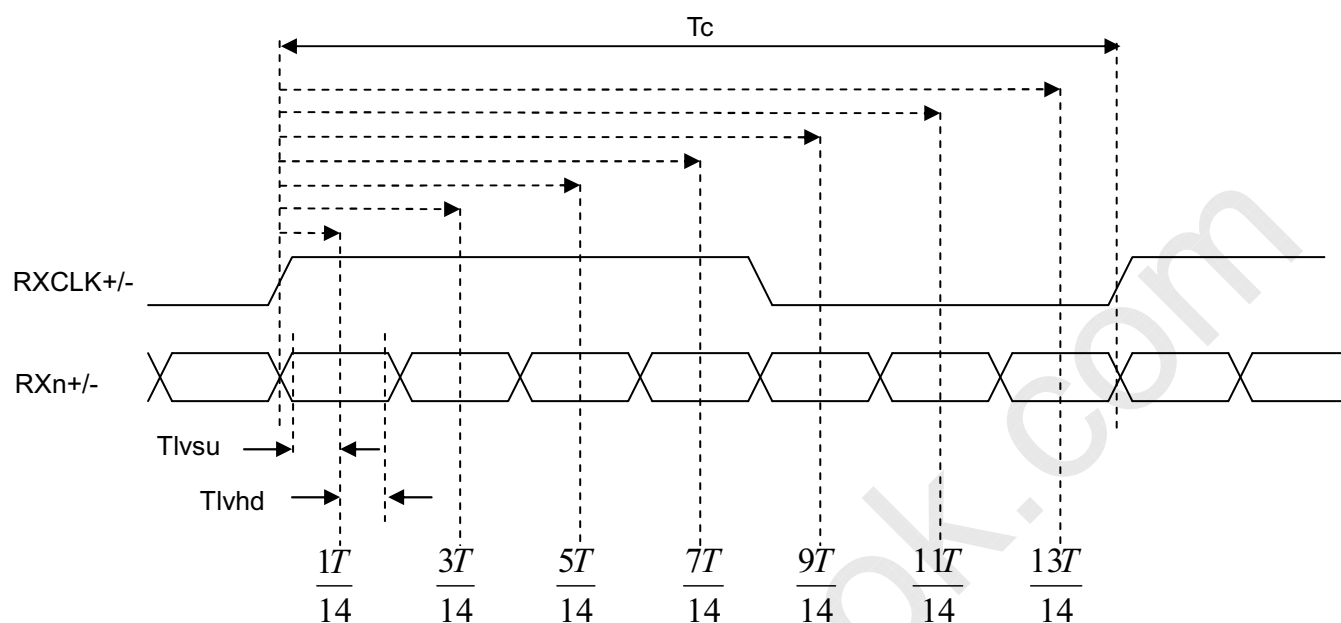

Note (5) The LVDS timing diagram and setup/hold time is defined and showing as the following figures.

**LVDS RECEIVER INTERFACE TIMING DIAGRAM**

## 6.2 POWER ON/OFF SEQUENCE

To prevent a latch-up or DC operation of LCD module, the power on/off sequence should be as the diagram below.

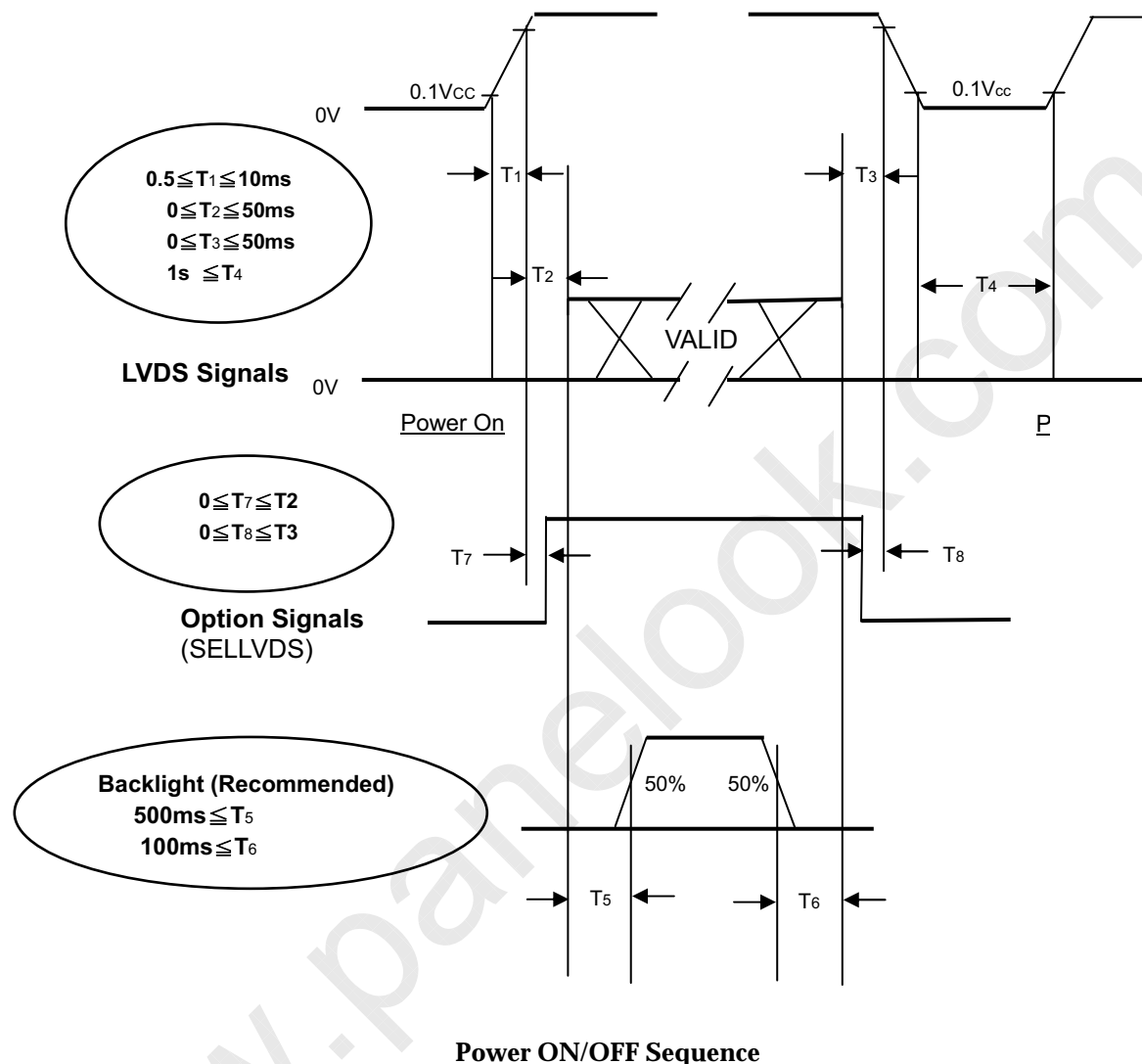

**Power ON/OFF Sequence**

Note (1) The supply voltage of the external system for the module input should follow the definition of Vcc.

Note (2) Apply the lamp voltage within the LCD operation range. When the backlight turns on before the LCD operation or the LCD turns off before the backlight turns off, the display may momentarily become abnormal screen.

Note (3) In case of Vcc is in off level, please keep the level of input signals on the low or high impedance. If  $T_2 < 0$ , that maybe cause electrical overstress failure.

Note (4)  $T_4$  should be measured after the module has been fully discharged between power off and on period.

Note (5) Interface signal shall not be kept at high impedance when the power is on.

## 7. OPTICAL CHARACTERISTICS

### 7.1 TEST CONDITIONS

Item	Symbol	Value	Unit
Ambient Temperature	Ta	25 ± 2	°C
Ambient Humidity	Ha	50 ± 10	%RH
Supply Voltage	Vcc	5.0	V
Input Signal	According to typical value in "3. ELECTRICAL CHARACTERISTICS"		
Lamp Current	I <sub>L</sub>	7	mA
Oscillating Frequency (Inverter)	F <sub>w</sub>	66 ± 3	KHz
Vertical Frame Rate	Fr	60	Hz

The LCD module should be stabilized at given temperature for 1 hour to avoid abrupt temperature change during measuring. In order to stabilize the luminance, the measurement should be executed after lighting backlight for 1 hour in a windless room.

## 7.2 OPTICAL SPECIFICATIONS

The relative measurement methods of optical characteristics are shown in 7.2. The following items should be measured under the test conditions described in 7.1 and stable environment shown in 7.1.

Item	Symbol	Condition	Min.	Typ.	Max.	Unit	Note	
Color Chromaticity	Red	Rcx	---	0.6883	---		(0) (5)	
		Rcy		0.3115				
	Green	Gcx		0.3347				
		Gcy		0.5615				
	Blue	Bcx		0.1974				
		Bcy		0.1237				
	White	Wcx		0.3203				
		Wcy		0.3595				
Center Transmittance	T%	$\theta_x=0^\circ, \theta_y=0^\circ$ with CMI module	---	7.1	---	%	(1) (7)	
Contrast Ratio	CR		---	800	---		(1) (3)	
Response Time	T <sub>R</sub>	$\theta_x=0^\circ, \theta_y=0^\circ$ with CMI Module@60Hz	---	1.3	---	ms	(4)	
	T <sub>F</sub>		---	3.7	---	ms		
White Variation	$\delta W$	$\theta_x=0^\circ, \theta_y=0^\circ$ with CMI module	---	---	1.3		(1) (6)	
Viewing Angle	Horizontal	$\theta_{x+}$	CR $\geq$ 10 With CMI module	---	80	---	Deg.	(1) (2)
		$\theta_{x-}$		---	80	---		
	Vertical	$\theta_{y+}$		---	80	---		
		$\theta_{y-}$		---	70	---		

Note (0) Light source is the standard light source "C" which is defined by CIE and driving voltage are based on suitable gamma voltages. The calculating method is as following:

1. Measure Module's and BLU's spectrum. White is without signal input and R, G, B are with signal input. BLU (for V216B1-L04) is supplied by CMI.
2. Calculate cell's spectrum.
3. Calculate cell's chromaticity by using the spectrum of standard light source "C".

Note (1) Light source is the BLU which is supplied by CMI and driving voltage are based on suitable gamma voltages.

Note (2) Definition of Viewing Angle ( $\theta_x, \theta_y$ ):

Viewing angles are measured by Autronic Conoscope Cono-80.

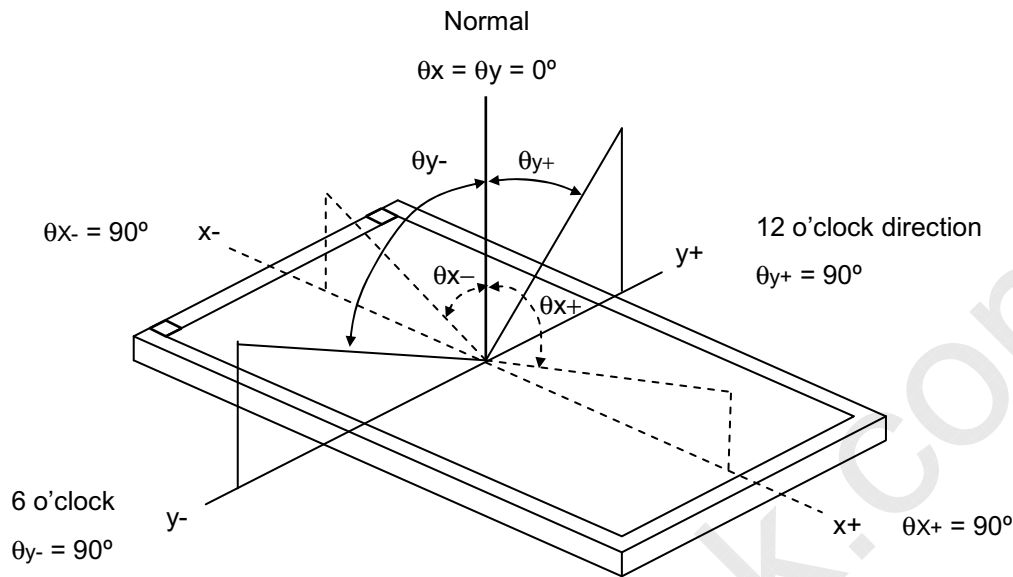

Note (3) Definition of Contrast Ratio (CR):

The contrast ratio can be calculated by the following expression.

$$\text{Contrast Ratio (CR)} = L_{255} / L_0$$

L255: Luminance of gray level 255

L0: Luminance of gray level 0

$$CR = CR(X),$$

where CR (X) is corresponding to the Contrast Ratio of the point X at the figure in Note (6).

Note (4) Definition of Response Time ( $T_R, T_F$ ):

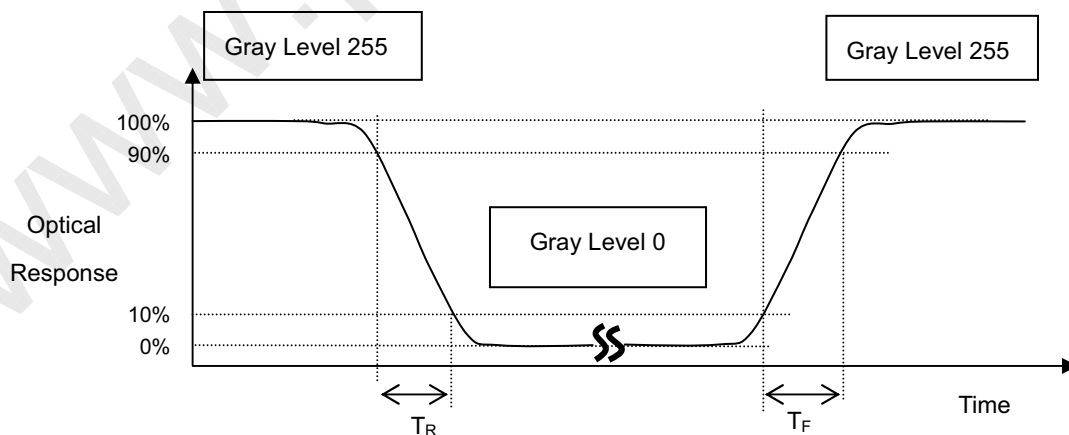

## Note (5) Measurement Setup:

The LCD module should be stabilized at given temperature for 1 hour to avoid abrupt temperature change during measuring. In order to stabilize the luminance, the measurement should be executed after lighting Backlight for 1 hour in a windless room.

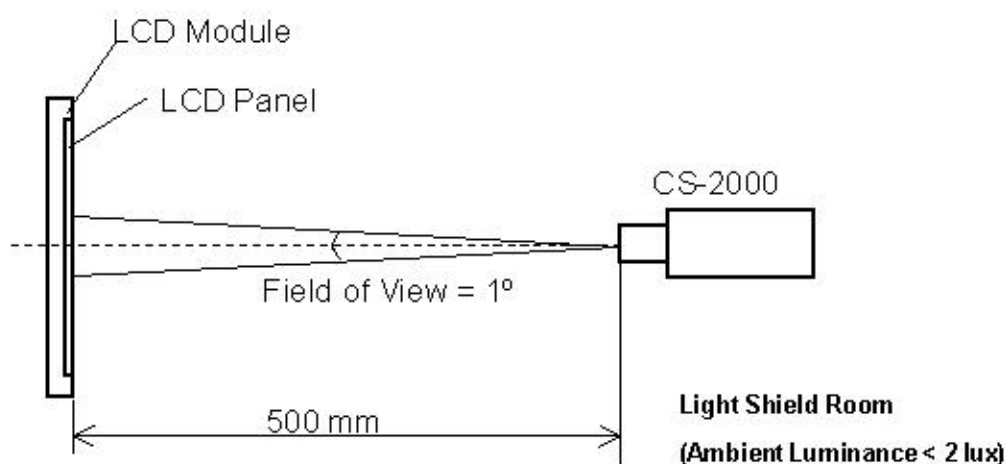

## Note (6) Definition of White Variation ( $\delta W$ ):

Measure the luminance of gray level 255 at 5 points

$$\delta W = \text{Maximum [L (1), L (2), L (3), L (4), L (5)]} / \text{Minimum [L (1), L (2), L (3), L (4), L (5)]}$$

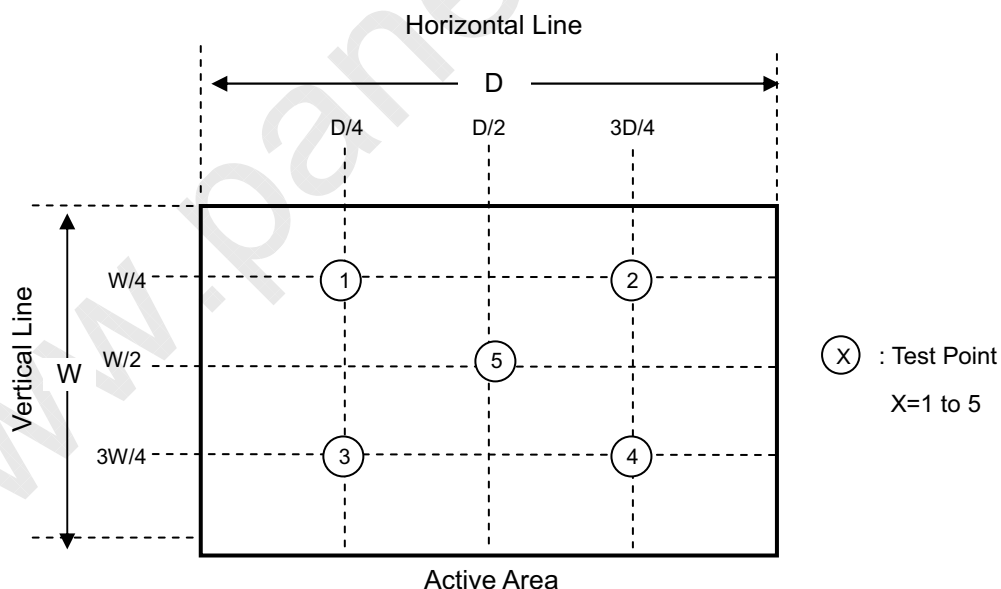

## Note (7) Definition of Transmittance (T%) :

Module is without signal input.

$$\text{Transmittance} = \frac{\text{Luminance of LCD module}}{\text{Luminance of backlight}} \times 100\%$$

## 8. DEFINITION OF LABELS

### 8.1 OPEN CELL LABEL

The barcode nameplate is pasted on each open cell as illustration for CMI internal control.

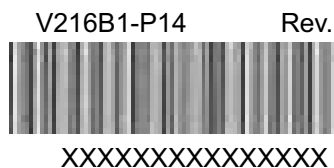

### 8.2 CARTON LABEL

The barcode nameplate is pasted on each box as illustration, and its definitions are as following explanation.

P.O. NO. \_\_\_\_\_

Parts ID. \_\_\_\_\_

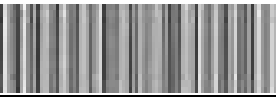
Carton ID.  Quantities   27  

XXXXXXXXXXXXXXXXXX

Made in Taiwan

P.O. NO. \_\_\_\_\_

Parts ID. \_\_\_\_\_

Carton ID.  Quantities   27  

XXXXXXXXXXXXXXXXXX

Made in China

- (a) Model Name: V216B1- P14
- (b) Carton ID: CMI internal control
- (c) Quantities: 27

## 9. PACKAGING

### 9.1 PACKAGING SPECIFICATIONS

- (1) 27 PCS LCD TV Panels / 1 Box
- (2) Box dimensions : 640 (L) X 490 (W) X 320 (H)
- (3) Weight : approximately 24 Kg

### 9.2 PACKAGING METHOD

Figures 9-1 and 9-2 are the packing method.

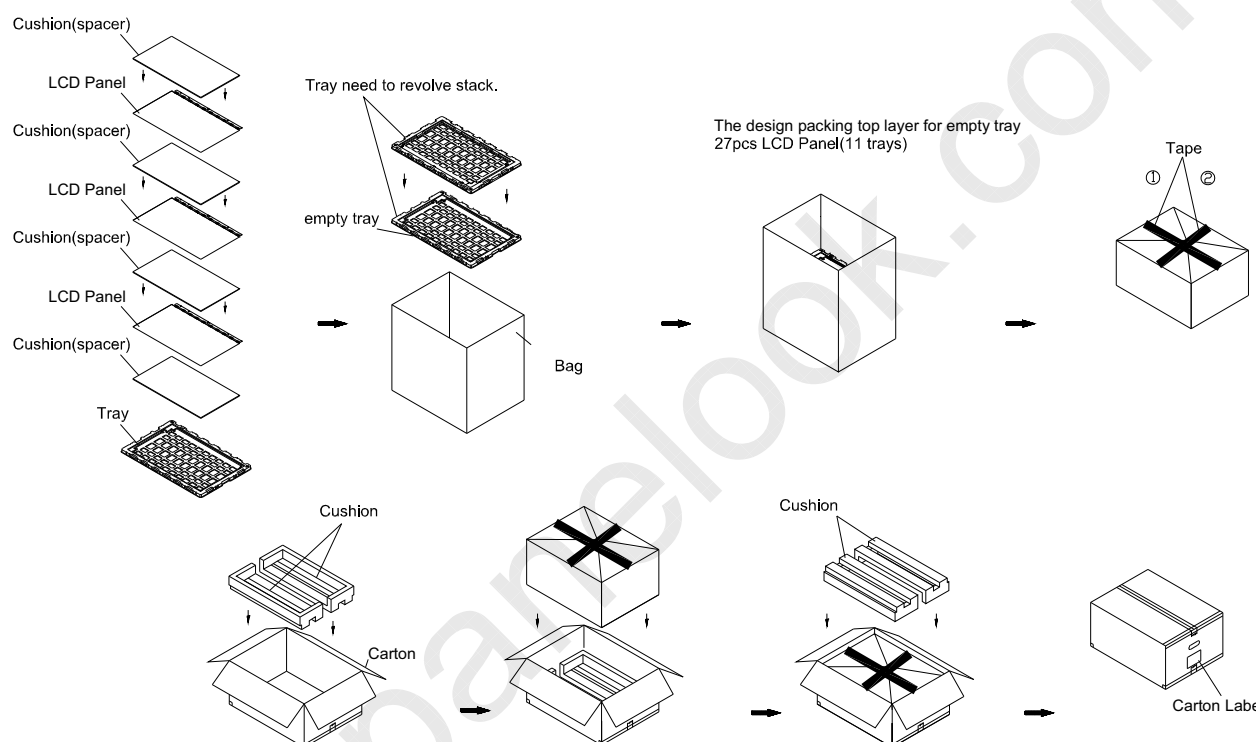
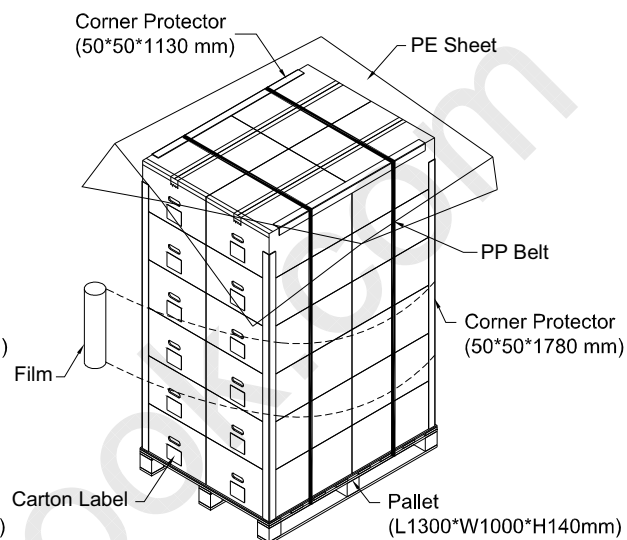
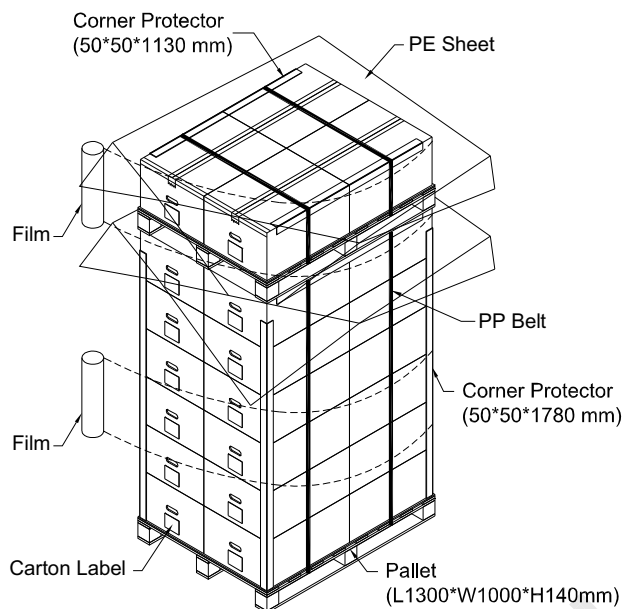

Figure.9-1 packing method



Sea / Land Transportation  
(40ft HQ Container)

Sea / Land Transportation



Air Transportation

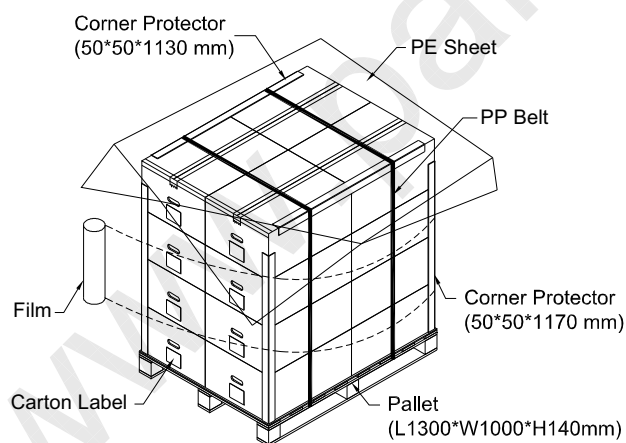

Figure.9-2 packing method

**10. PRECAUTIONS****10.1 ASSEMBLY AND HANDLING PRECAUTIONS**

- (1) Do not apply rough force such as bending or twisting to the product during assembly.
- (2) To assemble backlight or install module into user's system can be only in clean working areas. The dust and oil may cause electrical short or worsen the polarizer.
- (3) It is not permitted to have pressure or impulse on the module because the LCD panel will be damaged.
- (4) Always follow the correct power sequence when the product is connecting and operating. This can prevent damage to the CMOS LSI chips during latch-up.
- (5) Do not pull the I/F connector in or out while the module is operating.
- (6) Use a soft dry cloth without chemicals for cleaning, because the surface of polarizer is very soft and easily scratched.
- (7) It is dangerous that moisture come into or contacted the product, because moisture may damage the product when it is operating.
- (8) High temperature or humidity may reduce the performance of module. Please store this product within the specified storage conditions.
- (9) When ambient temperature is lower than 10°C may reduce the display quality. For example, the response time will become slowly.

**10.2 SAFETY PRECAUTIONS**

- (1) If the liquid crystal material leaks from the panel, it should be kept away from the eyes or mouth. In case of contact with hands, skin or clothes, it has to be washed away thoroughly with soap.
- (2) After the product's end of life, it is not harmful in case of normal operation and storage.

