

- Tentative Specification
 Preliminary Specification
 Approval Specification

MODEL NO.: V216BG1
SUFFIX: LE1

Customer:	
APPROVED BY	SIGNATURE
Name / Title _____	_____
Note	
Please return 1 copy for your confirmation with your signature and comments.	

Approved By	Checked By	Prepared By
Chao-Chun Chung	Roger Huang	Carlos Lee

CONTENTS

1. GENERAL DESCRIPTION	5
1.1 OVERVIEW	5
1.2 FEATURES.....	5
1.3 APPLICATION.....	5
1.4 GENERAL SPECIFICATIONS	5
1.5 MECHANICAL SPECIFICATIONS.....	6
2. ABSOLUTE MAXIMUM RATINGS.....	7
2.1 ABSOLUTE RATINGS OF ENVIRONMENT	7
2.2 PACKAGE STORAGE	8
2.3 ELECTRICAL ABSOLUTE RATINGS	8
2.3.1 TFT LCD MODULE.....	8
2.3.2 BACKLIGHT CONVERTER UNIT.....	8
3. ELECTRICAL CHARACTERISTICS	9
3.1 TFT LCD MODULE	9
3.2 BACKLIGHT CONNECTOR PIN CONFIGURATION.....	12
3.2.1 LED LIGHT BAR CHARACTERISTICS (Ta=25±2°C)	12
4. BLOCK DIAGRAM OF INTERFACE.....	13
4.1 TFT LCD MODULE	13
5. INPUT TERMINAL PIN ASSIGNMENT.....	14
5.1 TFT LCD Module Input	14
5.2 BACKLIGHT UNIT.....	15
5.3 BLOCK DIAGRAM OF INTERFACE	16
5.4 LVDS INTERFACE	17
5.5 COLOR DATA INPUT ASSIGNMENT	18
6. INTERFACE TIMING	19
6.1 INPUT SIGNAL TIMING SPECIFICATIONS.....	19
6.2 POWER ON/OFF SEQUENCE.....	22
7. OPTICAL CHARACTERISTICS.....	23
7.1 TEST CONDITIONS	23
7.2 OPTICAL SPECIFICATIONS.....	24

8. PRECAUTIONS.....	28
8.1 ASSEMBLY AND HANDLING PRECAUTIONS.....	28
8.2 SAFETY PRECAUTIONS	28
9. DEFINITION OF LABELS.....	29
9.1 CMI MODULE LABEL	29
10. PACKAGING.....	30
10.1 PACKAGING SPECIFICATIONS.....	30
10.2 PACKAGING METHOD	30
11. MECHANICAL CHARACTERISTIC.....	32

REVISION HISTORY

Version	Date	Page(New)	Section	Description
Ver. 2.0	Dec 12, 2011	All	All	The specification was first issued.
Ver. 2.1	Feb 09, 2012	33	11	Deleted "film material list" label.

1. GENERAL DESCRIPTION

1.1 OVERVIEW

V216BG1-LE1 is a 21.6" TFT Liquid Crystal Display module with LED Backlight unit and a 30pin 1ch-LVDS interface. This module supports 1366 x 768 (16:9 wide screen) formats and can display 16.7M colors (6-bit+FRC colors). The converter for backlight is not built-in.

1.2 FEATURES

- Excellent brightness (250 nits)
- Contrast ratio (1000:1)
- Fast response time (5 ms)
- Color saturation (NTSC 72%)
- 1366 x 768 pixels (16:9 wide screen) resolution
- DE (Data Enable) only mode
- LVDS (Low Voltage Differential Signaling) interface
- Viewing angle : 170(H)/160(V) (CR>10) TN technology
- RoHS compliance

1.3 APPLICATION

- Standard Living Room TVs
- MFM Application

1.4 GENERAL SPECIFICATIONS

Item	Specification	Unit	Note
Active Area	477.417(H) x 268.416 (V) (21.6" diagonal)	mm	(1)
Bezel Opening Area	481.5 (H) x 272.5 (V)	mm	
Driver Element	a-si TFT active matrix		
Pixel Number	1366 x R.G.B. x 768	pixel	
Pixel Pitch(Sub Pixel)	0.1165 (H) x 0.3495 (V)	mm	
Pixel Arrangement	RGB vertical stripe		
Display Colors	16.7M	color	
Display Operation Mode	Transmissive mode / Normally white		
Surface Treatment	Anti-Glare coating (Haze 25%), Hard coating(3H)		

Note (1) Please refer to the attached drawings in chapter 11 for more information about the front and back outlines.

1.5 MECHANICAL SPECIFICATIONS

Item		Min.	Typ.	Max.	Unit	Note
Module Size	Horizontal (H)	500.5	501	501.5	mm	(1)
	Vertical (V)	296.5	297	297.5	mm	(1)
	Depth (D)	10.6	11.1	11.6	mm	(2)
Weight		—	1940	—	g	

Note (1) Please refer to the attached drawings for more information of front and back outline dimensions.

Note (2) Module Depth is between bezel to T-CON cover.

2. ABSOLUTE MAXIMUM RATINGS

2.1 ABSOLUTE RATINGS OF ENVIRONMENT

Item	Symbol	Value		Unit	Note
		Min.	Max.		
Storage Temperature	T _{ST}	-20	+60	°C	(1)
Operating Ambient Temperature	T _{OP}	0	50	°C	(1) (2)
Shock (Non-Operating)	S _{NOP}	—	50	G	(3) (5)
Vibration (Non-Operating)	V _{NOP}	—	1.0	G	(4) (5)

Note (1) Temperature and relative humidity range is shown in the figure below.

- (a) 90 %RH Max. ($T_a \leq 40$ °C).
- (b) Wet-bulb temperature should be 39 °C Max. ($T_a > 40$ °C).
- (c) No condensation.

Note (2) The maximum operating temperature is based on the test condition that the surface temperature of display area is less than or equal to 65 °C with LCD module alone in a temperature controlled chamber. Thermal management should be considered in final product design to prevent the surface temperature of display area from being over 65 °C. The range of operating temperature may degrade in case of improper thermal management in final product design.

Note (3) 11 ms, half sine wave, 1 time for $\pm X$, $\pm Y$, $\pm Z$.

Note (4) 10 ~ 200 Hz, 10 min, 1 time each X, Y, Z.

Note (5) At testing Vibration and Shock, the fixture in holding the module has to be hard and rigid enough so that the module would not be twisted or bent by the fixture.

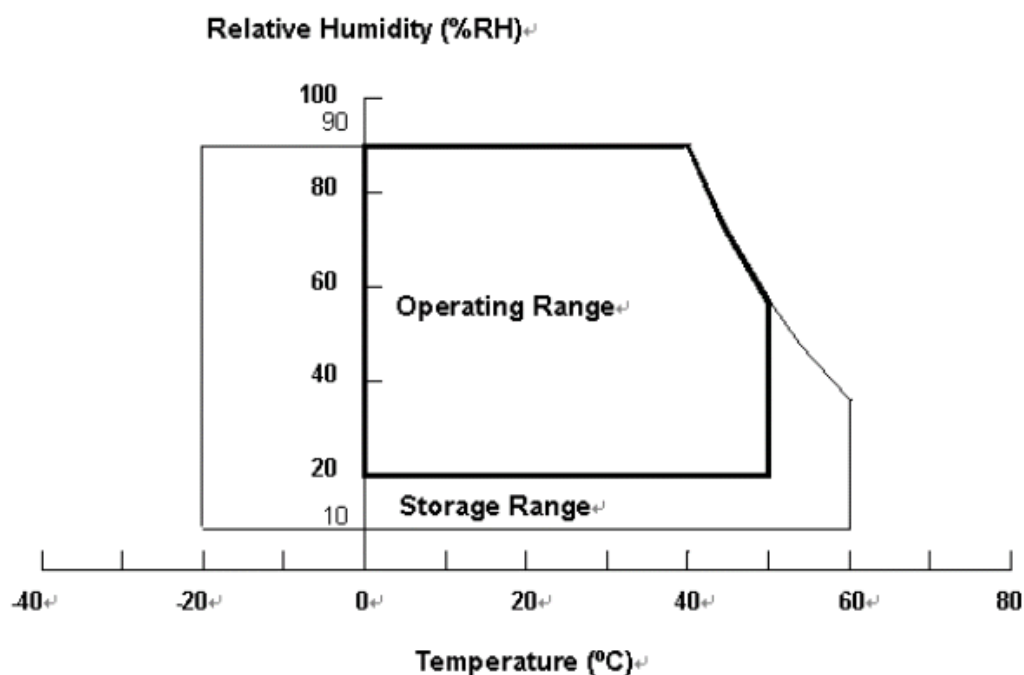

2.2 PACKAGE STORAGE

When storing modules as spares for a long time, the following precaution is necessary.

- (a) Do not leave the module in high temperature, and high humidity for a long time, it is highly recommended to store the module with temperature from 0 to 35 °C at normal humidity without condensation.
- (b) The module shall be stored in dark place. Do not store the TFT-LCD module in direct sunlight or fluorescent light.

2.3 ELECTRICAL ABSOLUTE RATINGS

2.3.1 TFT LCD MODULE

Item	Symbol	Value		Unit	Note
		Min.	Max.		
Power Supply Voltage	V _{CC}	-0.3	6.0	V	(1)
Logic Input Voltage	V _{IN}	-0.3	3.6	V	

2.3.2 BACKLIGHT CONVERTER UNIT

Item	Symbol	Value			Unit	Note
		Min.	Typ.	Max.		
LED Forward Current Per Input Pin	I _F	0	65	70	mA	(1) (2) Duty=100%
LED Reverse Current Per Input Pin	I _R	—	—	85	mA	
LED Pulse Forward Current Per Input Pin	I _{FP}	—	—	200	mA	Pulse Width ≤ 10msec. and Duty ≤ 10%

Note (1) Permanent damage to the device may occur if maximum values are exceeded. Function operation should be restricted to the conditions described under Normal Operating Conditions.

Note (2) Specified values are for input pin of LED light bar at Ta=25±2 °C (Refer to 3.2 for further information).

3. ELECTRICAL CHARACTERISTICS
3.1 TFT LCD MODULE

(Ta = 25 ± 2 °C)

Parameter		Symbol	Value			Unit	Note
			Min.	Typ.	Max.		
Power Supply Voltage		V _{CC}	4.5	5.0	5.5	V	(1)
Rush Current		I _{RUSH}	—	—	3.0	A	(2)
Power Supply Current	White	I _{CC}	—	0.30	—	A	(3)
	Black	I _{CC}	—	0.49	—	A	
	Horizontal Stripe	I _{CC}	—	0.51	—	A	
LVDS interface	Differential Input High Threshold Voltage	V _{LVTH}	+100	—	—	mV	(4)
	Differential Input Low Threshold Voltage	V _{LVTL}	—	—	-100	mV	
	Common Input Voltage	V _{CM}	1.0	1.2	1.4	V	
	Differential input voltage (single-end)	V _{ID}	200	—	600	mV	
	Terminating Resistor	R _T	—	100	—	ohm	
CMOS interface	Input High Threshold Voltage	V _{IH}	2.7	—	3.3	V	
	Input Low Threshold Voltage	V _{IL}	0	—	0.7	V	

Note (1) The module should be always operated within the above ranges.

Note (2) Measurement condition:

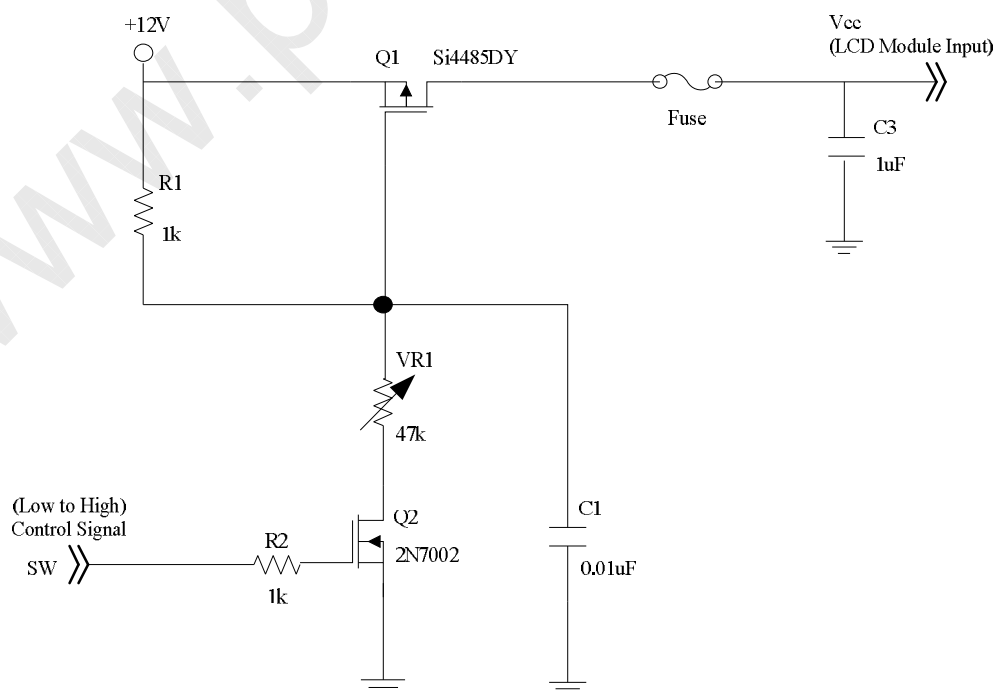

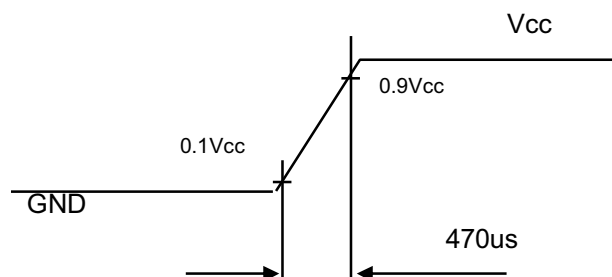
Vcc rising time is 470us

Note (3) The specified power supply current is under the conditions at $V_{cc} = 5\text{ V}$, $T_a = 25 \pm 2\text{ }^\circ\text{C}$, $f_v = 60\text{ Hz}$, whereas a power dissipation check pattern below is displayed.

a. White Pattern



Active Area

b. Black Pattern



Active Area

c. Horizontal Pattern

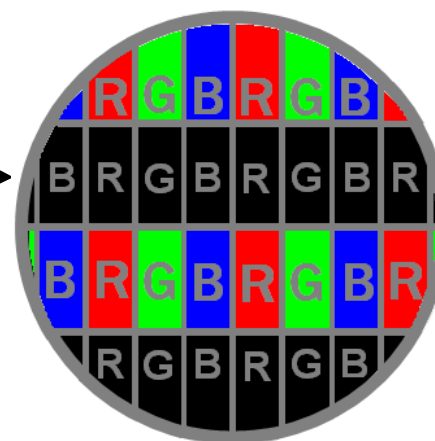
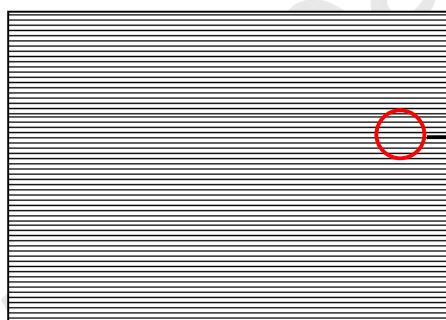

Note (4) The LVDS input characteristics are as follows:

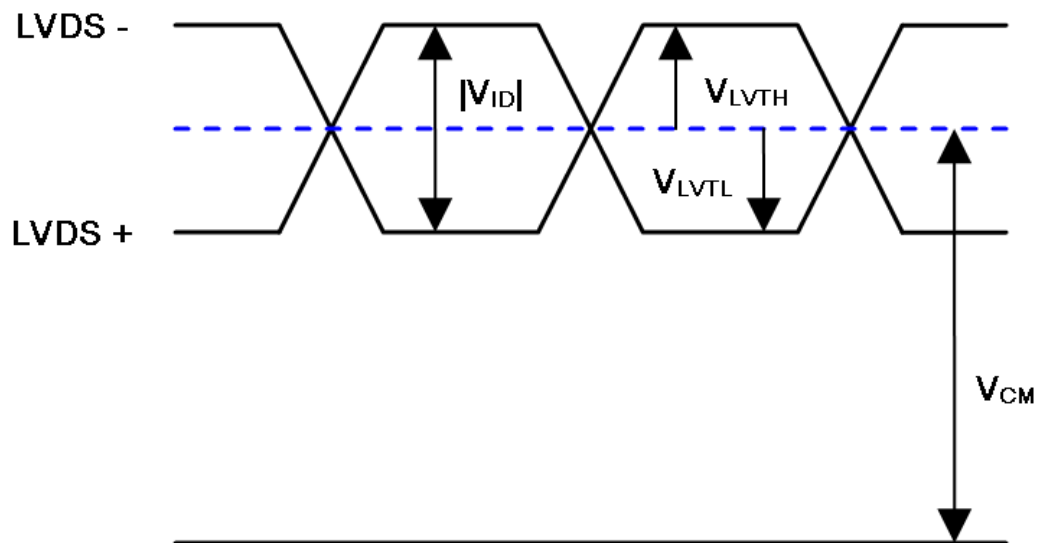

3.2 BACKLIGHT CONNECTOR PIN CONFIGURATION

3.2.1 LED LIGHT BAR CHARACTERISTICS (Ta=25±2°C)

Parameter	Symbol	Value			Unit	Note
		Min.	Typ.	Max.		
LED Light Bar Input Voltage Per Input Pin	V _{PIN}	33.6	37.2	40.8	V	(1) Duty=100%, I _{PIN} =65mA
LED Light Bar Current Per Input Pin	I _{PIN}	0	65	70	mA	(1) (2) Duty=100%
LED Life Time	L _{LED}	30000	—	—	Hrs	(3)
Power Consumption	P _{BL}	—	9.67	10.61	W	(1) Duty=100%, I _{PIN} =65mA

Note (1) LED light bar input voltage and current are measured by utilizing a true RMS multimeter as shown below:

Note (2) $P_{BL} = I_{PIN} \times V_{PIN} \times (4)$ input pins

Note (3) The lifetime of LED is defined as the time when LED packages continue to operate under the conditions at $T_a = 25 \pm 2 \text{ }^\circ\text{C}$ and $I = (65)\text{mA}$ (per chip) until the brightness becomes $\leq 50\%$ of its original value.

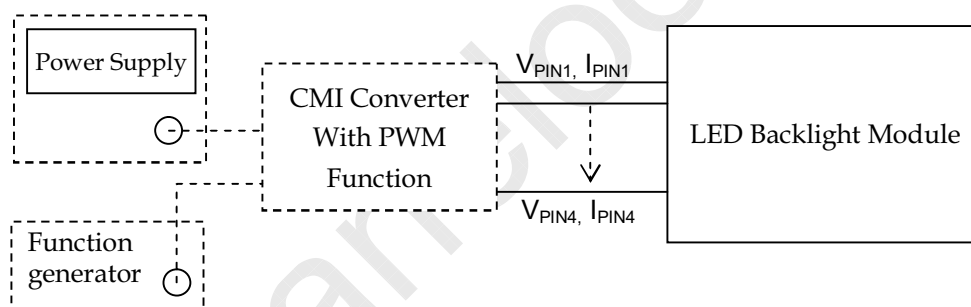

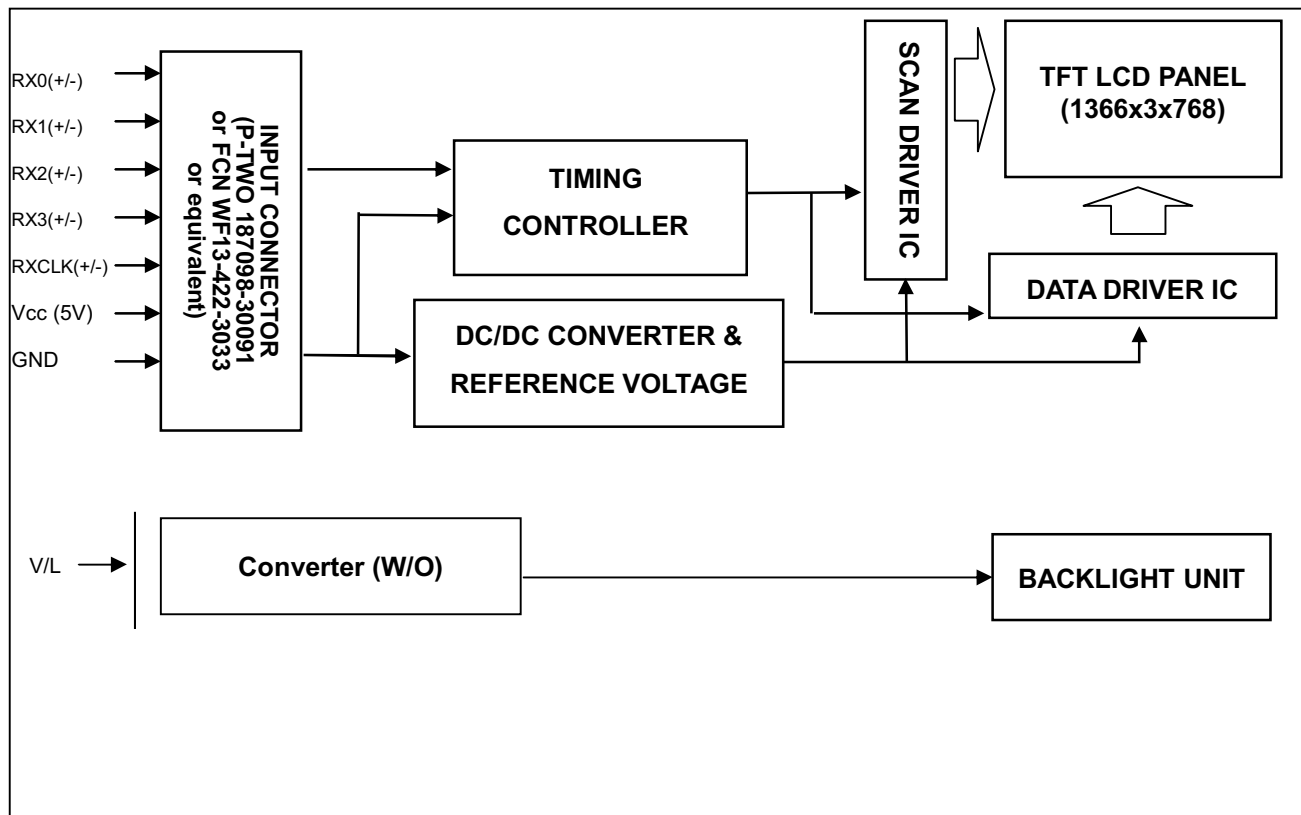
4. BLOCK DIAGRAM OF INTERFACE
4.1 TFT LCD MODULE

5. INPUT TERMINAL PIN ASSIGNMENT

5.1 TFT LCD Module Input

Pin No.	Symbol	Description	Note
1	NC	No connection	(2)
2	NC	No connection	(2)
3	NC	No connection	(2)
4	GND	Ground	
5	RX0-	Negative transmission data of pixel 0	
6	RX0+	Positive transmission data of pixel 0	
7	GND	Ground	
8	RX1-	Negative transmission data of pixel 1	
9	RX1+	Positive transmission data of pixel 1	
10	GND	Ground	
11	RX2-	Negative transmission data of pixel 2	
12	RX2+	Positive transmission data of pixel 2	
13	GND	Ground	
14	RXCLK-	Negative of clock	
15	RXCLK+	Positive of clock	
16	GND	Ground	
17	RX3-	Negative transmission data of pixel 3	
18	RX3+	Positive transmission data of pixel 3	
19	GND	Ground	
20	NC	No connection	(2)
21	NC	No connection	(2)
22	NC	No connection	(2)
23	GND	Ground	
24	GND	Ground	
25	NC	No connection	(2)
26	VCC	Power supply: +5V	
27	VCC	Power supply: +5V	
28	VCC	Power supply: +5V	
29	VCC	Power supply: +5V	
30	VCC	Power supply: +5V	

Note (1) Connector part no.: P-TWO 187098-30091 or FCN WF13-422-3033 or equivalent

LVDS connector pin order defined as follows

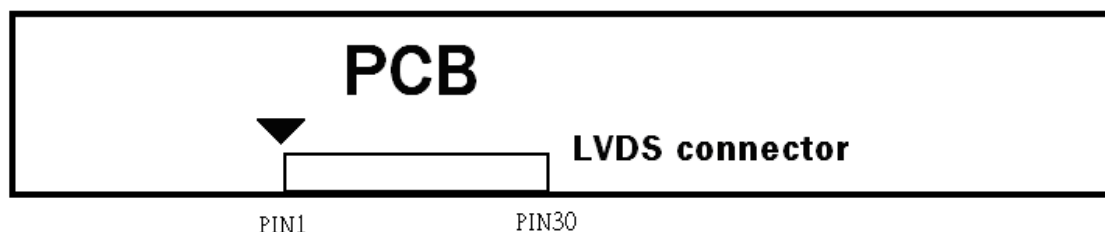

Note (2) Reserved for CMI internal use, please leave it open.

5.2 BACKLIGHT UNIT

The pin configuration for the housing and the leader wire is shown in the table below.

CN1	
Pin	Description
1	Cathode of LED string
2	Cathode of LED string
3	VLED
4	VLED
5	Cathode of LED string
6	Cathode of LED string

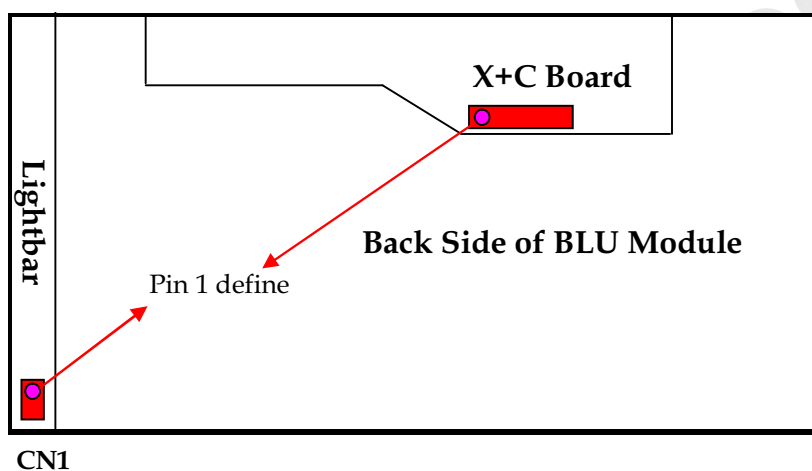

Lightbar Connector CN1: CviLux, CI1406M1HRJ-NH, or FCN WM13-406-063N or compatible

5.3 BLOCK DIAGRAM OF INTERFACE

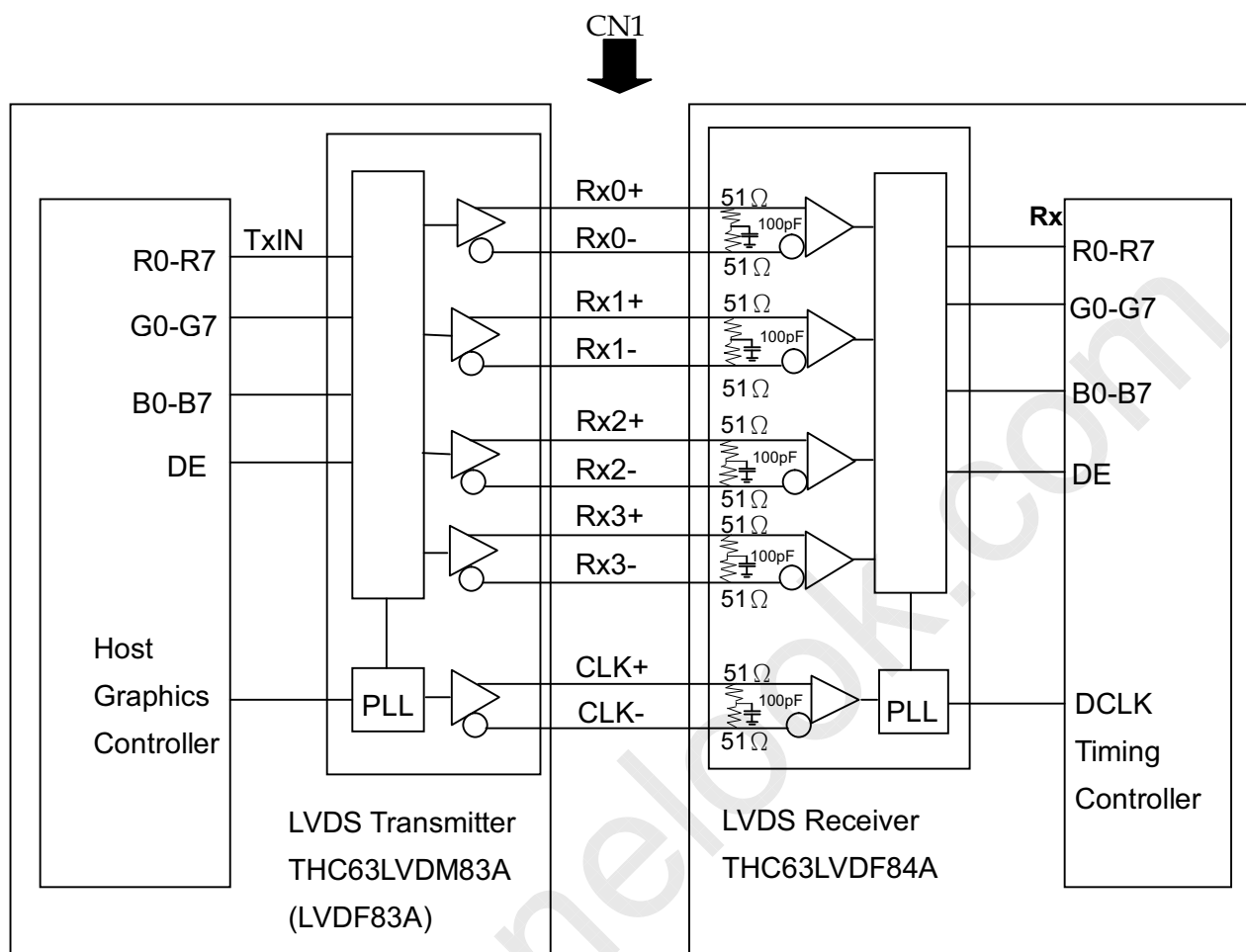

R0~R7 : Pixel R Data
 G0~G7 : Pixel G Data
 B0~B7 : Pixel B Data
 DE : Data enable signal
 DCLK : Data clock signal

Note (1) The system must have the transmitter to drive the module.

Note (2) LVDS cable impedance shall be 50 ohms per signal line or about 100 ohms per twist-pair line when it is used differentially.

5.4 LVDS INTERFACE

VESA Format

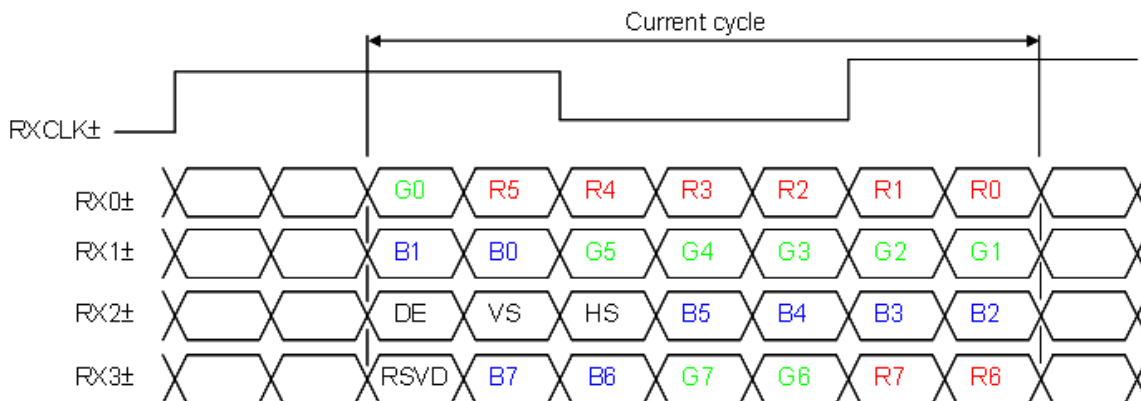

R0~R7 : Pixel R Data (7; MSB, 0; LSB)

G0~G7 : Pixel G Data (7; MSB, 0; LSB)

B0~B7 : Pixel B Data (7; MSB, 0; LSB)

DE : Data enable signal

5.5 COLOR DATA INPUT ASSIGNMENT

The brightness of each primary color (red, green and blue) is based on the 8-bit gray scale data input for the color. The higher the binary input, the brighter the color. The table below provides the assignment of the color versus data input.

Color		Data Signal																						
		Red								Green								Blue						
		R7	R6	R5	R4	R3	R2	R1	R0	G7	G6	G5	G4	G3	G2	G1	G0	B7	B6	B5	B4	B3	B2	B1
Basic Colors	Black	0	0	0	0	0	0	0	0	0	0	0	0	0	0	0	0	0	0	0	0	0	0	0
	Red	1	1	1	1	1	1	1	1	0	0	0	0	0	0	0	0	0	0	0	0	0	0	0
	Green	0	0	0	0	0	0	0	0	1	1	1	1	1	1	1	1	0	0	0	0	0	0	0
	Blue	0	0	0	0	0	0	0	0	0	0	0	0	0	0	0	0	1	1	1	1	1	1	1
	Cyan	0	0	0	0	0	0	0	0	1	1	1	1	1	1	1	1	1	1	1	1	1	1	1
	Magenta	1	1	1	1	1	1	1	1	0	0	0	0	0	0	0	0	1	1	1	1	1	1	1
	Yellow	1	1	1	1	1	1	1	1	1	1	1	1	1	1	1	1	0	0	0	0	0	0	0
	White	1	1	1	1	1	1	1	1	1	1	1	1	1	1	1	1	1	1	1	1	1	1	1
Gray Scale Of Red	Red (0) / Dark	0	0	0	0	0	0	0	0	0	0	0	0	0	0	0	0	0	0	0	0	0	0	
	Red (1)	0	0	0	0	0	0	0	1	0	0	0	0	0	0	0	0	0	0	0	0	0	0	
	Red (2)	0	0	0	0	0	0	1	0	0	0	0	0	0	0	0	0	0	0	0	0	0	0	
	:	:	:	:	:	:	:	:	:	:	:	:	:	:	:	:	:	:	:	:	:	:	:	
	:	:	:	:	:	:	:	:	:	:	:	:	:	:	:	:	:	:	:	:	:	:	:	
	Red (253)	1	1	1	1	1	1	0	1	0	0	0	0	0	0	0	0	0	0	0	0	0	0	
	Red (254)	1	1	1	1	1	1	1	0	0	0	0	0	0	0	0	0	0	0	0	0	0	0	
	Red (255)	1	1	1	1	1	1	1	1	0	0	0	0	0	0	0	0	0	0	0	0	0	0	
Gray Scale Of Green	Green (0) / Dark	0	0	0	0	0	0	0	0	0	0	0	0	0	0	0	0	0	0	0	0	0	0	
	Green (1)	0	0	0	0	0	0	0	0	0	0	0	0	0	0	0	1	0	0	0	0	0	0	
	Green (2)	0	0	0	0	0	0	0	0	0	0	0	0	0	0	1	0	0	0	0	0	0	0	
	:	:	:	:	:	:	:	:	:	:	:	:	:	:	:	:	:	:	:	:	:	:	:	
	:	:	:	:	:	:	:	:	:	:	:	:	:	:	:	:	:	:	:	:	:	:	:	
	Green (253)	0	0	0	0	0	0	0	0	1	1	1	1	1	1	0	1	0	0	0	0	0	0	
	Green (254)	0	0	0	0	0	0	0	0	1	1	1	1	1	1	1	0	0	0	0	0	0	0	
	Green (255)	0	0	0	0	0	0	0	0	1	1	1	1	1	1	1	0	0	0	0	0	0	0	
Gray Scale Of Blue	Blue (0) / Dark	0	0	0	0	0	0	0	0	0	0	0	0	0	0	0	0	0	0	0	0	0	0	
	Blue (1)	0	0	0	0	0	0	0	0	0	0	0	0	0	0	0	0	0	0	0	0	0	1	
	Blue (2)	0	0	0	0	0	0	0	0	0	0	0	0	0	0	0	0	0	0	0	0	0	1	
	:	:	:	:	:	:	:	:	:	:	:	:	:	:	:	:	:	:	:	:	:	:	:	
	:	:	:	:	:	:	:	:	:	:	:	:	:	:	:	:	:	:	:	:	:	:	:	
	Blue (253)	0	0	0	0	0	0	0	0	0	0	0	0	0	0	0	0	1	1	1	1	1	1	
	Blue (254)	0	0	0	0	0	0	0	0	0	0	0	0	0	0	0	0	1	1	1	1	1	1	
	Blue (255)	0	0	0	0	0	0	0	0	0	0	0	0	0	0	0	0	1	1	1	1	1	1	

Note (1) 0: Low Level Voltage, 1: High Level Voltage

6. INTERFACE TIMING

6.1 INPUT SIGNAL TIMING SPECIFICATIONS

(Ta = 25 ± 2 °C)

The input signal timing specifications are shown as the following table and timing diagram.

Signal	Item	Symbol	Min.	Typ.	Max.	Unit	Note
LVDS Receiver Clock	Frequency	F _{clkkin} (=1/TC)	60	76	82	MHz	
	Input cycle to cycle jitter	T _{rel}	—	—	200	ps	(3)
	Spread spectrum modulation range	F _{clkkin_mod}	F _{clkkin} -2%	—	F _{clkkin} +2%	MHz	(4)
	Spread spectrum modulation frequency	F _{SSM}	—	—	200	KHz	
LVDS Receiver Data	Setup Time	T _{lvsu}	600	—	—	ps	(5)
	Hold Time	T _{lvhd}	600	—	—	ps	
Vertical Active Display Term	Frame Rate	F _{r5}	47	50	53	Hz	
		F _{r6}	57	60	63	Hz	
	Total	T _v	778	806	986	Th	T _v =T _{vd} +T _{vb}
	Display	T _{vd}	768	768	768	Th	
	Blank	T _{vb}	10	38	218	Th	
Horizontal Active Display Term	Total	T _h	1446	1560	1936	T _c	T _h =T _{hd} +T _{hb}
	Display	T _{hd}	1366	1366	1366	T _c	
	Blank	T _{hb}	80	194	570	T _c	

Note (1) Please make sure the range of pixel clock has follow the below equation :

$$F_{clkkin}(\max) \geq Fr6 \times Tv \times Th$$

$$Fr5 \times Tv \times Th \geq F_{clkkin}(\min)$$

Note (2) This module is operated in DE only mode and please follow the input signal timing diagram below :

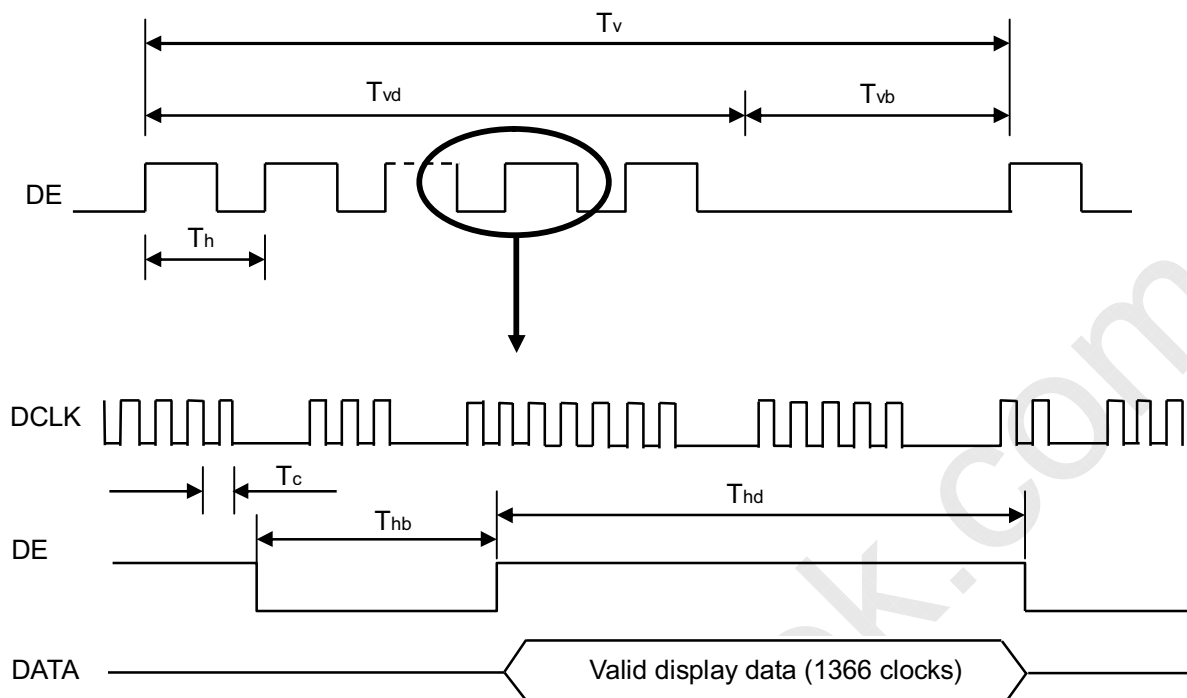
INPUT SIGNAL TIMING DIAGRAM

Note (3) The input clock cycle-to-cycle jitter is defined as below figures. $Trcl = |T_1 - T_2|$

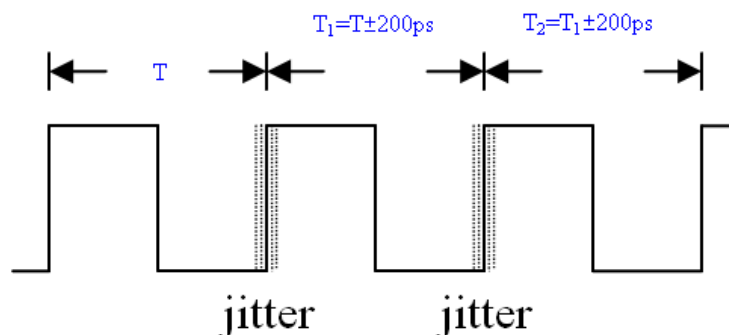

Note (4) The SSCG (Spread spectrum clock generator) is defined as below figures.

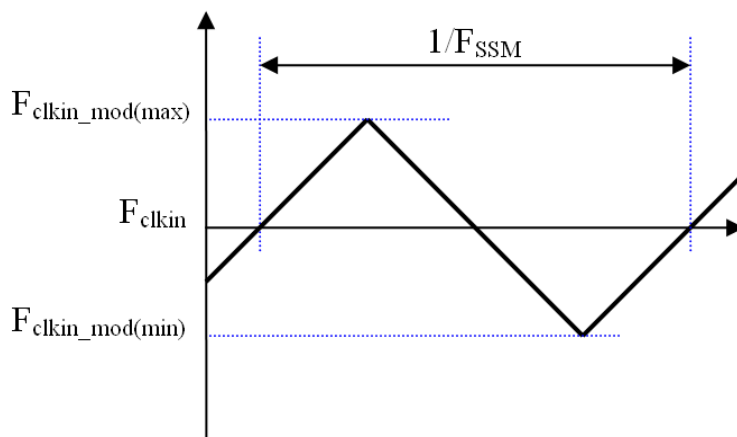

Note (5) The LVDS timing diagram and setup/hold time is defined and showing as the following figures.

LVDS RECEIVER INTERFACE TIMING DIAGRAM

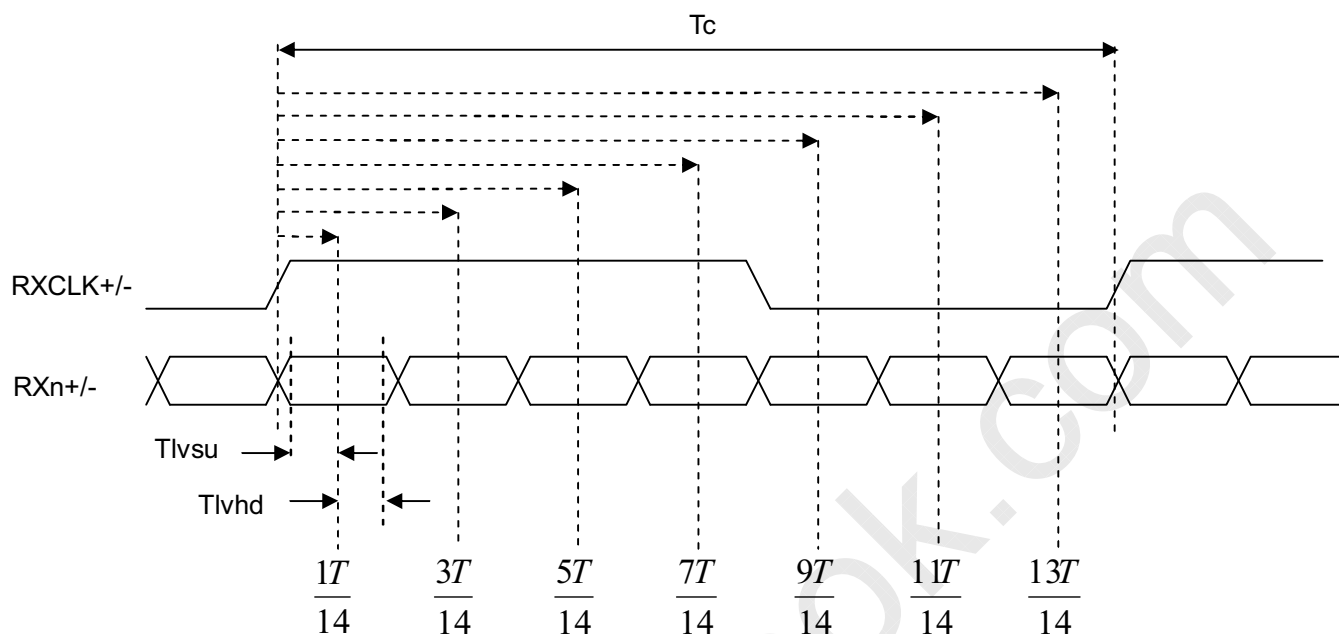

6.2 POWER ON/OFF SEQUENCE

($T_a = 25 \pm 2 \text{ }^\circ\text{C}$)

To prevent a latch-up or DC operation of LCD module, the power on/off sequence should be as the diagram below.

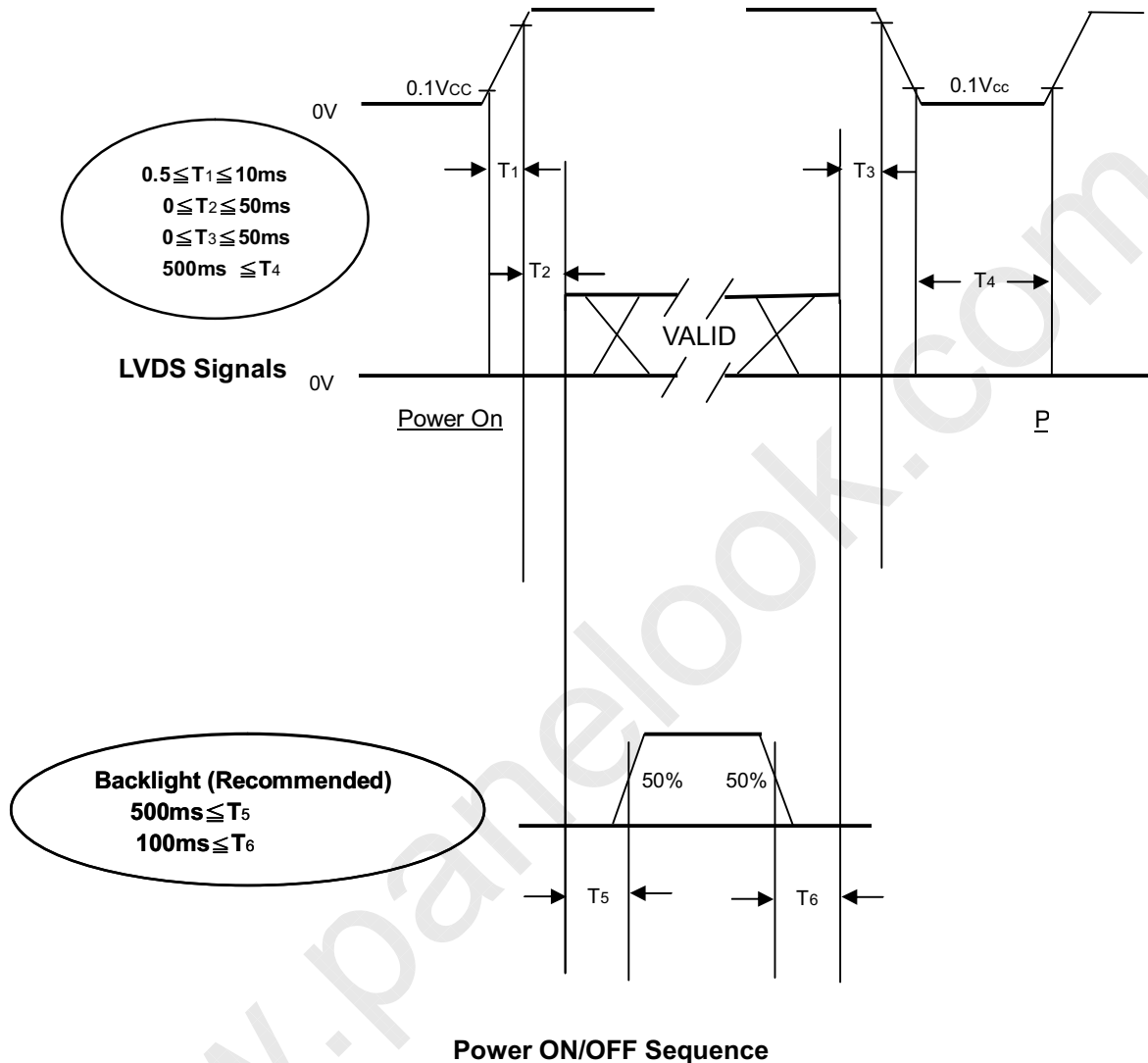

Note (1) The supply voltage of the external system for the module input should follow the definition of Vcc.

Note (2) Apply the lamp voltage within the LCD operation range. When the backlight turns on before the LCD operation or the LCD turns off before the backlight turns off, the display may momentarily become abnormal screen.

Note (3) In case of Vcc is in off level, please keep the level of input signals on the low or high impedance. If $T_2 < 0$, that maybe cause electrical overstress failure.

Note (4) T4 should be measured after the module has been fully discharged between power off and on period.

Note (5) Interface signal shall not be kept at high impedance when the power is on.

7. OPTICAL CHARACTERISTICS

7.1 TEST CONDITIONS

Item	Symbol	Value	Unit
Ambient Temperature	Ta	25 ± 2	°C
Ambient Humidity	Ha	50 ± 10	%RH
Supply Voltage	V _{CC}	5.0	V
Input Signal	According to typical value in "3. ELECTRICAL CHARACTERISTICS"		
LED Light Bar Input Current Per Input Pin	I _{PIN}	65 ± 1.95	mA _{DC}
PWM Duty Ratio	D	100	%
LED Light Bar Test Converter	CMI 35-D065452 + Transfer board		

The LCD module should be stabilized at given temperature for 1 hour to avoid abrupt temperature change during measuring. In order to stabilize the luminance, the measurement should be executed after lighting backlight for 1 hour in a windless room.

7.2 OPTICAL SPECIFICATIONS

The relative measurement methods of optical characteristics are shown in 7.2. The following items should be measured under the test conditions described in 7.1 and stable environment shown in 7.1.

Item		Symbol	Condition	Min.	Typ.	Max.	Unit	Note
Contrast Ratio		CR	$\theta_x=0^\circ, \theta_y=0^\circ$ Viewing angle at normal direction	700	1000	—		(2)
Response Time		T_R		—	1.3	2.2	ms	(3)
		T_F		—	3.7	5.8		
Center Luminance of White		L_C		200	250	—	cd/m ²	(4)
White Variation		δW		—	—	1.3		(7)
Cross Talk		CT		—	—	4	%	(5)
Color Chromaticity	Red	R_x		Typ. -0.03	Typ. +0.03	0.629		(6)
		R_y				0.334		
	Green	G_x				0.305		
		G_y				0.626		
	Blue	B_x	0.157					
		B_y	0.054					
	White	W_x	0.285					
		W_y	0.293					
	Color Gamut	CG	—			72		
Viewing Angle	Horizontal	$\theta_{x+} + \theta_{x-}$	CR>10	150	170	—	Deg.	(1) (6)
	Vertical	$\theta_{y+} + \theta_{y-}$	CR>10	140	160	—		
	Horizontal	$\theta_{x+} + \theta_{x-}$	CR>5	160	178	—		
	Vertical	$\theta_{y+} + \theta_{y-}$	CR>5	150	170	—		

Note (1) Definition of Viewing Angle (θ_x, θ_y):

Viewing angles are measured by Autronic Conoscope Cono-80

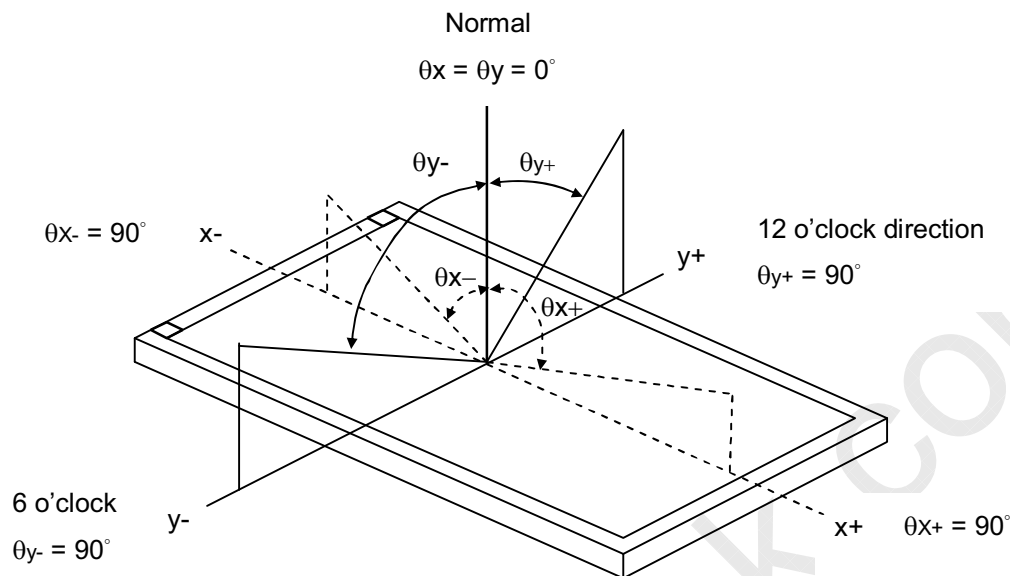

Note (2) Definition of Contrast Ratio (CR):

The contrast ratio can be calculated by the following expression.

$$\text{Contrast Ratio (CR)} = L_{255} / L_0$$

L255: Luminance of gray level 255

L0: Luminance of gray level 0

$$CR = CR(5),$$

CR (X) is corresponding to the Contrast Ratio of the point X at the figure in Note (7).

Note (3) Definition of Response Time (T_R, T_F):

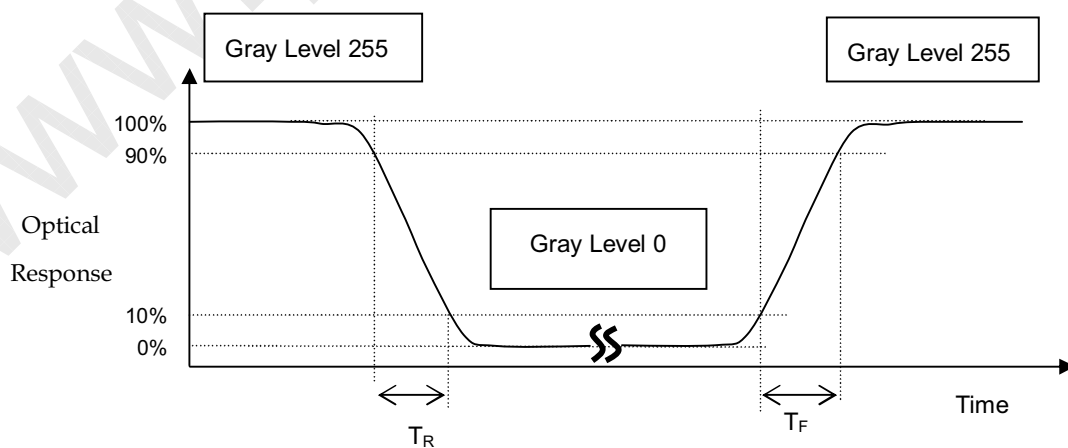

Note (4) Definition of Luminance of White (L_C):

Measure the luminance of gray level 255 at center point and 5 points

$$L_C = L(5)$$

$L(X)$ is corresponding to the luminance of the point X at the figure in Note (7).

Note (5) Definition of Cross Talk (CT):

$$CT = |Y_B - Y_A| / Y_A \times 100 (\%)$$

Where:

Y_A = Luminance of measured location without gray level 0 pattern (cd/m^2)

Y_B = Luminance of measured location with gray level 0 pattern (cd/m^2)

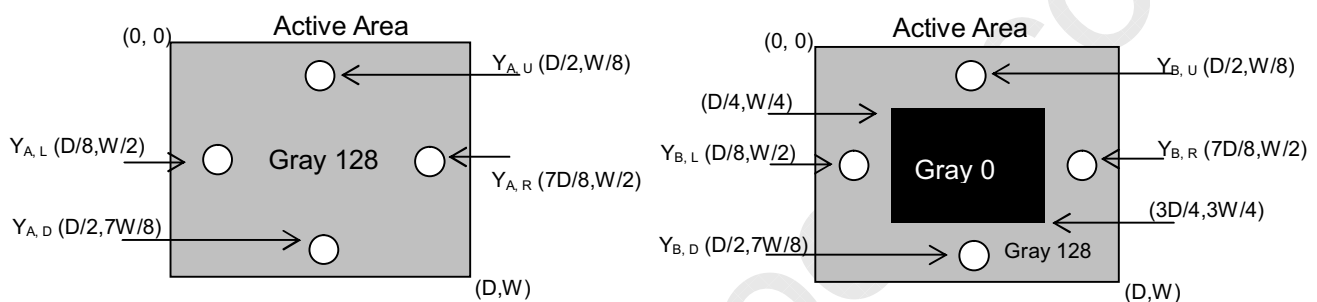

Note (6) Measurement Setup:

The LCD module should be stabilized at given temperature for 1 hour to avoid abrupt temperature change during measuring. In order to stabilize the luminance, the measurement should be executed after lighting Backlight for 1 hour in a windless room.

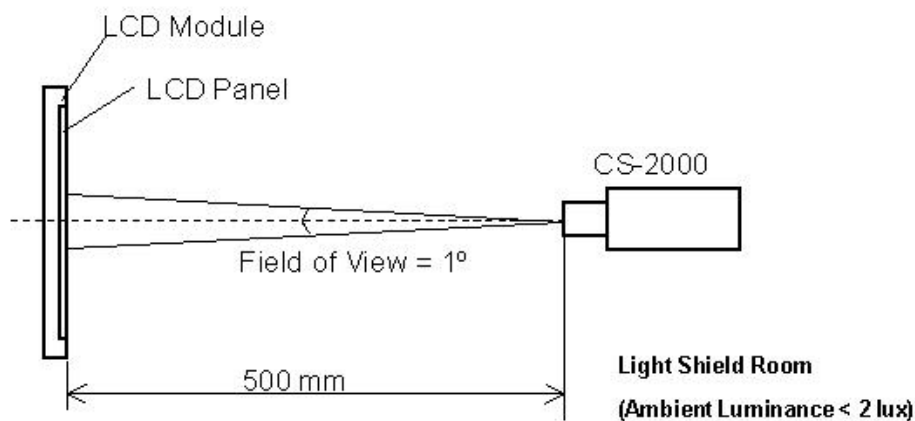

Note (7) Definition of White Variation (δW):

Measure the luminance of gray level 255 at 5 points

$$\delta W = \text{Maximum [L (1), L (2), L (3), L (4), L (5)]} / \text{Minimum [L (1), L (2), L (3), L (4), L (5)]}$$

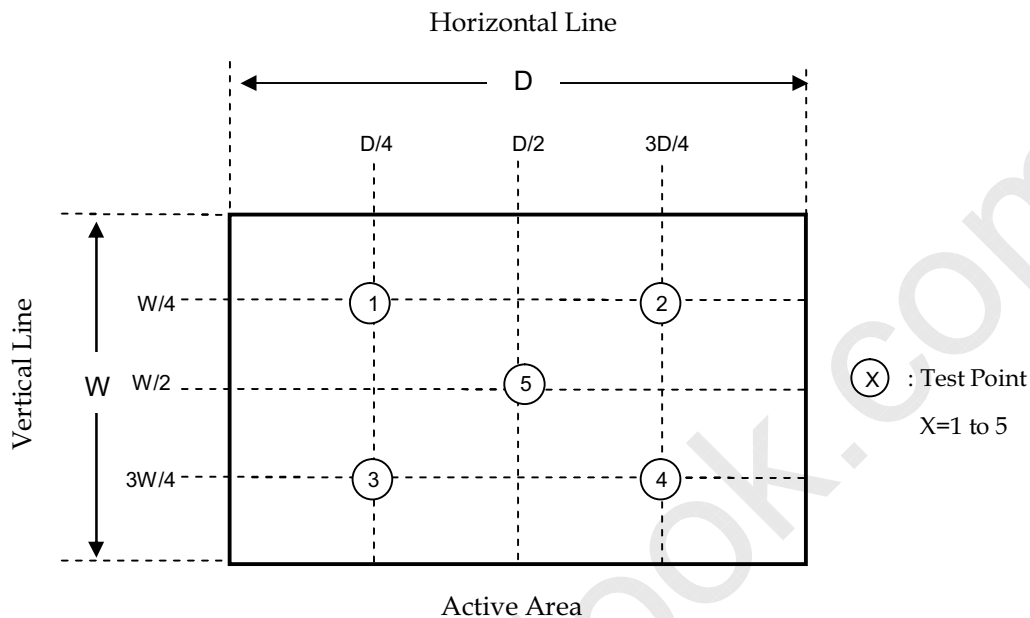

8. PRECAUTIONS

8.1 ASSEMBLY AND HANDLING PRECAUTIONS

- [1] Do not apply rough force such as bending or twisting to the module during assembly.
- [2] It is recommended to assemble or to install a module into the user's system in clean working areas. The dust and oil may cause electrical short or worsen the polarizer.
- [3] Do not apply pressure or impulse to the module to prevent the damage of LCD panel and Backlight.
- [4] Always follow the correct power-on sequence when the LCD module is turned on. This can prevent the damage and latch-up of the CMOS LSI chips.
- [5] Do not plug in or pull out the I/F connector while the module is in operation.
- [6] Do not disassemble the module.
- [7] Use a soft dry cloth without chemicals for cleaning, because the surface of polarizer is very soft and easily scratched.
- [8] Moisture can easily penetrate into LCD module and may cause the damage during operation.
- [9] When storing modules as spares for a long time, the following precaution is necessary.
 - [9.1] Do not leave the module in high temperature, and high humidity for a long time. It is highly recommended to store the module with temperature from 0 to 35°C at normal humidity without condensation.
 - [9.2] The module shall be stored in dark place. Do not store the TFT-LCD module in direct sunlight or fluorescent light.
- [10] When ambient temperature is lower than 10°C, the display quality might be reduced. For example, the response time will become slow.

8.2 SAFETY PRECAUTIONS

- [1] If the liquid crystal material leaks from the panel, it should be kept away from the eyes or mouth. In case of contact with hands, skin or clothes, it has to be washed away thoroughly with soap.
- [2] After the module's end of life, it is not harmful in case of normal operation and storage.

9. DEFINITION OF LABELS
9.1 CMI MODULE LABEL

The barcode nameplate is pasted on each module as illustration, and its definitions are as following explanation.

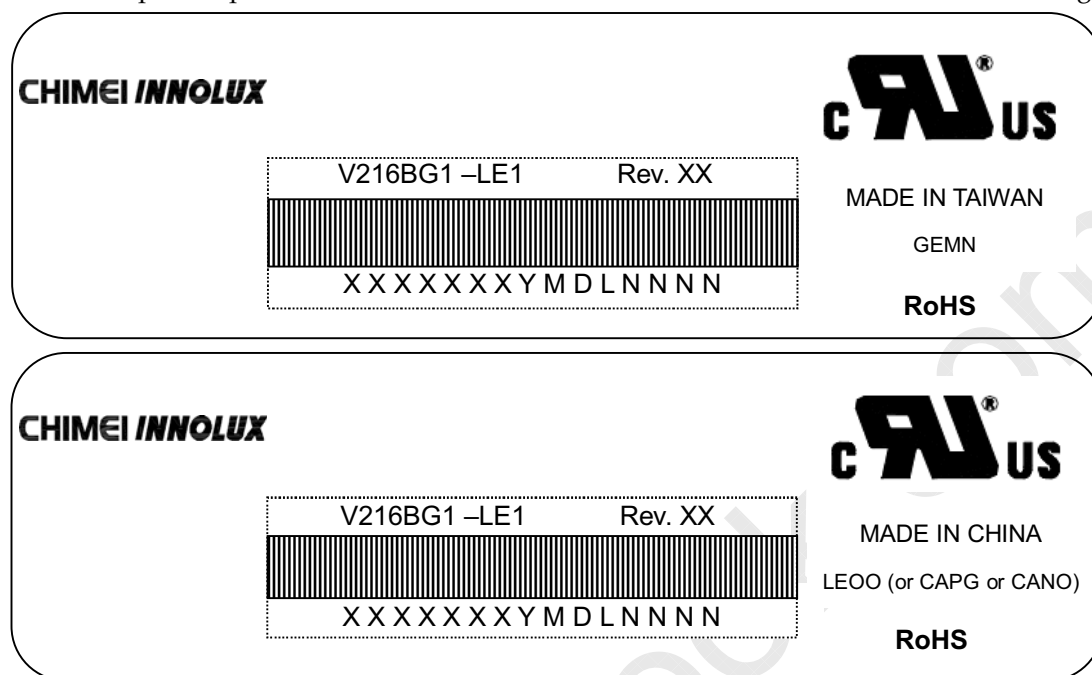

Model Name: V216BG1-LE1

Revision: Rev. XX, for example: A0, A1... B1, B2... or C1, C2...etc.

Serial ID: XXXXXXXXYMDLNNNN

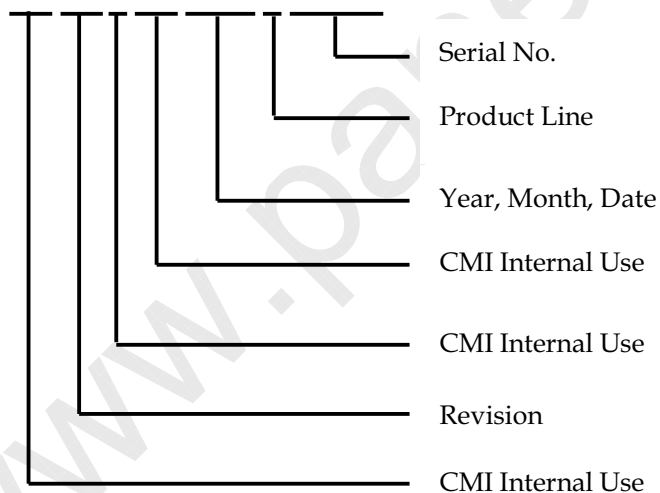

Serial ID includes the information as below:

Manufactured Date:

Year: 2001=1, 2002=2, 2003=3, 2004=4...2010=0, 2011=1, 2012=2...

Month: 1~9, A~C, for Jan. ~ Dec.

Day: 1~9, A~Y, for 1st to 31st, exclude I, O, and U.

Revision Code: Cover all the change

Serial No.: Manufacturing sequence of product

Product Line: 1 → Line1, 2 → Line 2, ...etc.

10. PACKAGING

10.1 PACKAGING SPECIFICATIONS

- (1) 15 LCD TV modules / 1 Box
- (2) Box dimensions : 563(L) x 417(W) x 375(H)mm
- (3) Weight : approximately 32Kg(15 modules per box)

10.2 PACKAGING METHOD

Figures 10-1 and 10-2 are the packing method

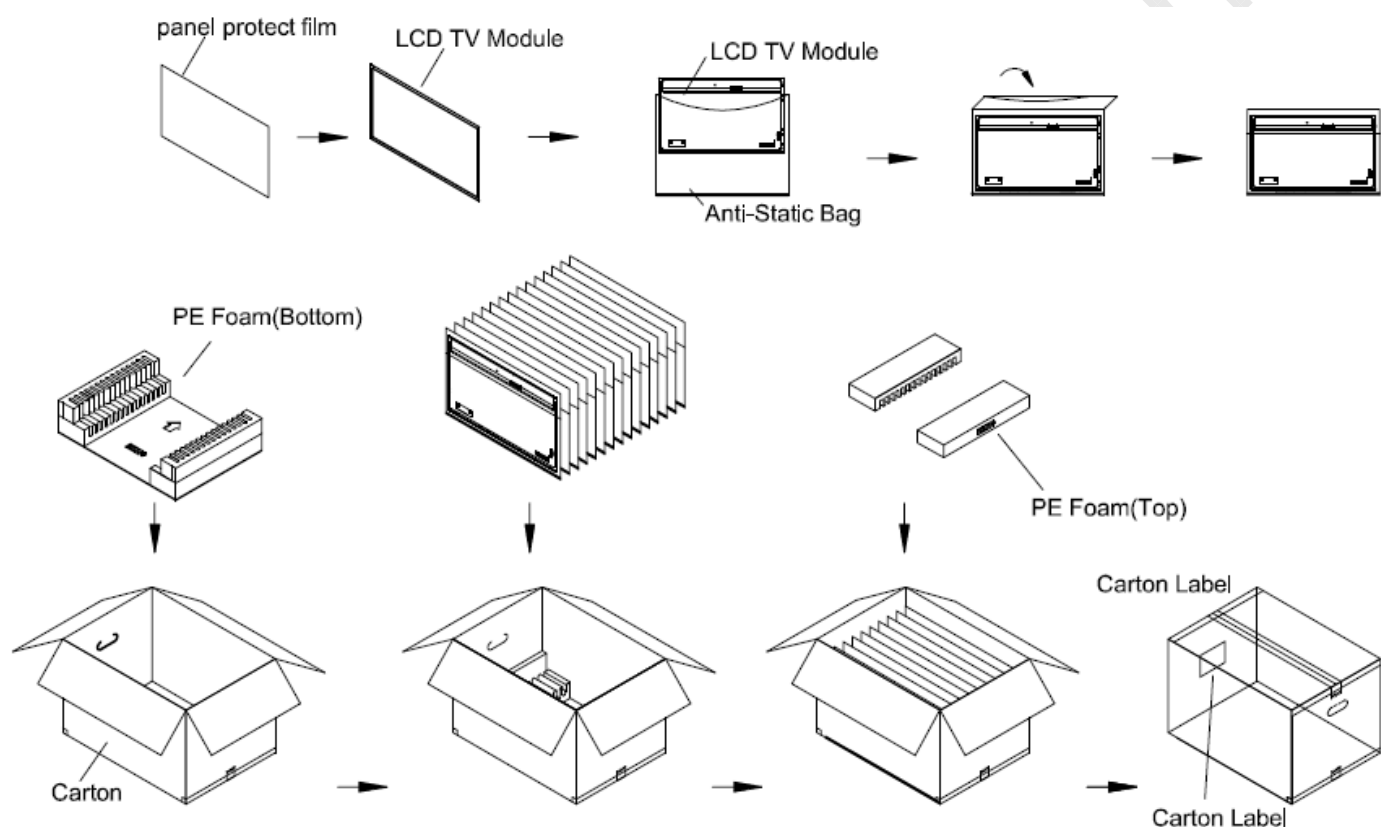
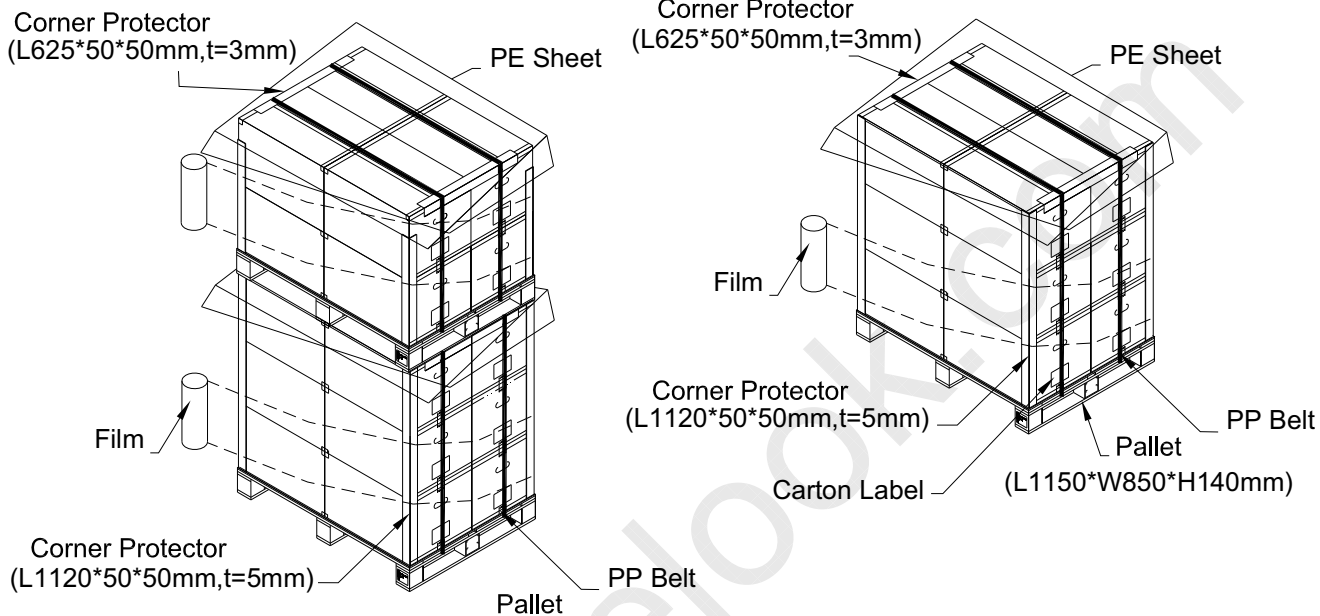

Figure 10-1 packing method

Sea / Land Transportation (40ft Container)

Air Transportation



Sea / Land Transportation (40ft HQ Container)

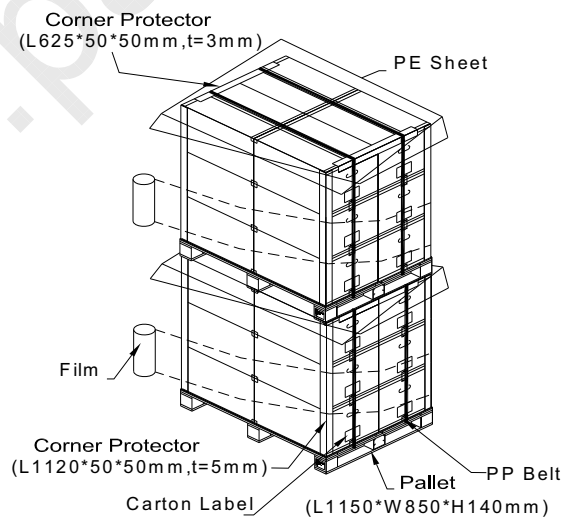

Figure 10-2 packing method

11. MECHANICAL CHARACTERISTIC

