

- Tentative Specification
- Preliminary Specification
- Approval Specification

MODEL NO.: V236BJ1

SUFFIX: PE2

|                                                                    |           |
|--------------------------------------------------------------------|-----------|
| Revision: <u>C2</u>                                                |           |
| Customer:                                                          |           |
| APPROVED BY                                                        | SIGNATURE |
| <u>Name / Title</u> _____                                          |           |
| Note                                                               |           |
| _____                                                              |           |
| Please return 1 copy for your confirmation with your signature and |           |

| Approved By     | Checked By | Prepared By |
|-----------------|------------|-------------|
| Chao-Chun Chung | YP Lee     | Chris Chen  |

**CONTENTS**

|                                                       |    |
|-------------------------------------------------------|----|
| CONTENTS .....                                        | 2  |
| REVISION HISTORY .....                                | 4  |
| 1. GENERAL DESCRIPTION .....                          | 5  |
| 1.1 OVERVIEW .....                                    | 5  |
| 1.2 FEATURES .....                                    | 5  |
| 1.3 MECHANICAL SPECIFICATIONS .....                   | 6  |
| 2. ABSOLUTE MAXIMUM RATINGS .....                     | 7  |
| 2.1 ABSOLUTE RATINGS OF ENVIRONMENT .....             | 7  |
| 2.2 ABSOLUTE RATINGS OF ENVIRONMENT (OPEN CELL) ..... | 8  |
| 2.3 ELECTRICAL ABSOLUTE RATINGS .....                 | 8  |
| 2.3.1 TFT LCD MODULE .....                            | 8  |
| 3. ELECTRICAL CHARACTERISTICS .....                   | 9  |
| 3.1 TFT LCD OPEN CELL .....                           | 9  |
| 4. INPUT TERMINAL PIN ASSIGNMENT .....                | 11 |
| 4.1 TFT LCD OPEN CELL .....                           | 11 |
| 5. INPUT TERMINAL PIN ASSIGNMENT .....                | 12 |
| 5.1 TFT LCD OPEN CELL INPUT .....                     | 12 |
| 5.2 LVDS INTERFACE .....                              | 14 |
| 5.3 COLOR DATA INPUT ASSIGNMENT .....                 | 15 |
| 5.4 FLICKER (Vcom) ADJUSTMENT .....                   | 16 |
| 6. INTERFACE TIMING .....                             | 17 |
| 6.1 INPUT SIGNAL TIMING SPECIFICATIONS .....          | 17 |
| 6.2 POWER ON/OFF SEQUENCE .....                       | 19 |
| 7. OPTICAL CHARACTERISTICS .....                      | 20 |
| 7.1 TEST CONDITIONS .....                             | 20 |
| 7.2 OPTICAL SPECIFICATIONS .....                      | 21 |
| 8. PRECAUTIONS .....                                  | 24 |
| 8.1 ASSEMBLY AND HANDLING PRECAUTIONS .....           | 24 |

8.2 SAFETY PRECAUTIONS ..... 25

9. DEFINITION OF LABELS..... 26

    9.1 OPEN CELL LABEL ..... 26

10. PACKAGING..... 28

    10.1 PACKAGING SPECIFICATIONS ..... 28

    10.2 PACKAGING METHOD..... 28

    10.3 UNPACKING METHOD..... 29

11. MECHANICAL CHARACTERISTIC..... 30



**REVISION HISTORY**

| Version  | Date        | Page(New) | Section | Description                                  |
|----------|-------------|-----------|---------|----------------------------------------------|
| Ver. 2.0 | Apr.18 2014 | All       | All     | The Approval Specification was first Issued. |

液晶倉庫  
www.gotolcd.com

**1. GENERAL DESCRIPTION**

**1.1 OVERVIEW**

V236BJ1-PE2 is a 23.6" TFT Liquid Crystal Display product with driver ICs and 1ch-LVDS interface. This product supports 1366 x 768 HDTV format and can display 16.7M colors (8-bit). The backlight unit is not built in.

**1.2 FEATURES**

| CHARACTERISTICS ITEMS             | SPECIFICATIONS                                                                                                                       |
|-----------------------------------|--------------------------------------------------------------------------------------------------------------------------------------|
| Screen Diagonal [in]              | 23.6                                                                                                                                 |
| Pixels [lines]                    | 1366 x 768                                                                                                                           |
| Active Area [mm]                  | 521.4705 (H) x 293.184 (V) (23.6" diagonal)                                                                                          |
| Sub-Pixel Pitch [mm]              | 0.12725 (H) x 0.38175 (V)                                                                                                            |
| Pixel Arrangement                 | RGB Vertical Stripe                                                                                                                  |
| Weight [g]                        | 500 Typ. (g)                                                                                                                         |
| Physical Size [mm]                | 535.06 x 307.34 x 1.315 Typ.                                                                                                         |
| Display Mode                      | Transmissive Mode / Normally Black                                                                                                   |
| Contrast Ratio                    | Typ.3000:1<br>(Typical value measure by INX's Module)                                                                                |
| Glass thickness (Array / CF) [mm] | 0.5 / 0.5                                                                                                                            |
| Viewing Angle (CR>20)             | Typ. +88/-88(H), +88/-88(V) (CR ≥ 20)<br>(Typical value measured by INX's module)                                                    |
| Color Chromaticity                | R = (0.658, 0.325)<br>G = (0.277, 0.583)<br>B = (0.136, 0.104)<br>W= (0.310, 0.350)<br>* Please refer to "color chromaticity" in 7.2 |
| Cell Transparency [%]             | 5.6%<br>* Please refer to "Transmittance" in 7.2                                                                                     |
| Polarizer Surface Treatment       | Anti-Glare coating (Haze 1%)                                                                                                         |
| Rotation Function                 | Unachievable                                                                                                                         |
| Display Orientation               | Signal input with "INX"                                                                                                              |

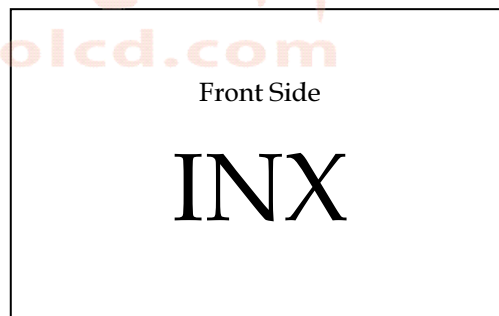
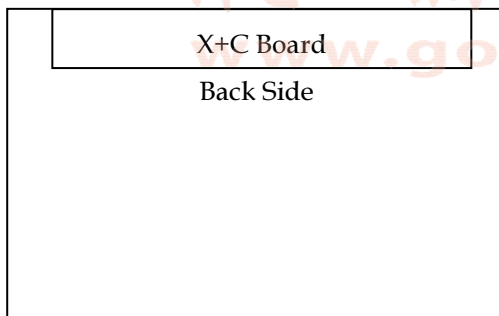

1.3 MECHANICAL SPECIFICATIONS

| Item                            | Min.                                                                                                           | Typ. | Max. | Unit | Note |
|---------------------------------|----------------------------------------------------------------------------------------------------------------|------|------|------|------|
| Weight                          | 460                                                                                                            | 500  | 540  | g    | -    |
| I/F connector mounting position | The mounting inclination of the connector makes the screen center within $\pm 0.5\text{mm}$ as the horizontal. |      |      |      | (2)  |

Note (1) Please refer to the attached drawings for more information of front and back outline dimensions.

Note (2) Connector mounting position

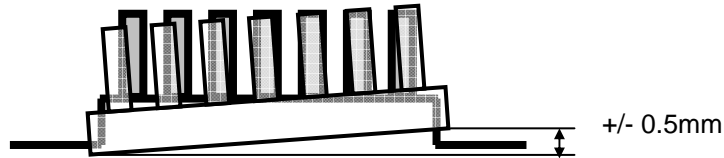

液晶倉庫  
www.gotolcd.com

**2. ABSOLUTE MAXIMUM RATINGS**

**2.1 ABSOLUTE RATINGS OF ENVIRONMENT**

| Item                          | Symbol | Value |      | Unit | Note                        |
|-------------------------------|--------|-------|------|------|-----------------------------|
|                               |        | Min.  | Max. |      |                             |
| Storage Temperature           | TST    | -20   | +60  | °C   | (1)<br>With INX Module      |
| Operating Ambient Temperature | TOP    | 0     | 50   | °C   | (1), (2)<br>With INX Module |

Note (1) Temperature and relative humidity range is shown in the figure below.

- (a) 90 %RH Max. ( $T_a \leq 40\text{ °C}$ ).
- (b) Wet-bulb temperature should be 39 °C Max. ( $T_a > 40\text{ °C}$ ).
- (c) No condensation.

Note (2) Thermal management should be considered in final product design to prevent the surface temperature of display area from being over 65 °C. The range of operating temperature may degrade in case of improper thermal management in final product design.

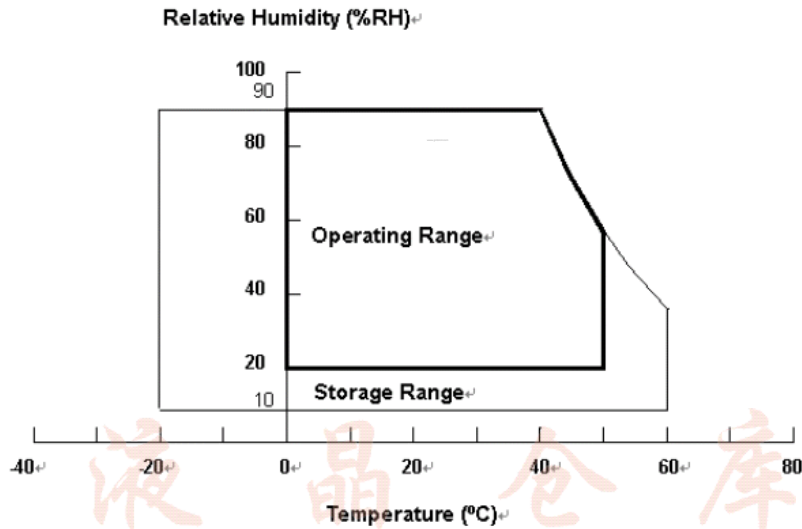

**2.2 ABSOLUTE RATINGS OF ENVIRONMENT (OPEN CELL)**

Recommended Storage Condition: With shipping package.

Recommended Storage temperature range: 25±5 °C

Recommended Storage humidity range: 50±10%RH

Recommended Shelf life: a month

**2.3 ELECTRICAL ABSOLUTE RATINGS**

**2.3.1 TFT LCD MODULE**

| Item                 | Symbol | Value |      | Unit | Note |
|----------------------|--------|-------|------|------|------|
|                      |        | Min.  | Max. |      |      |
| Power Supply Voltage | VCC    | -0.3  | 13.5 | V    | (1)  |
| Logic Input Voltage  | VIN    | -0.3  | 3.6  | V    |      |

Note (1) Permanent damage to the device may occur if maximum values are exceeded. Function operation should be restricted to the conditions described under Normal Operating Conditions.





**3. ELECTRICAL CHARACTERISTICS**

**3.1 TFT LCD OPEN CELL**

(Ta = 25 ± 2 °C)

| Parameter            | Symbol                                         | Value             |      |       | Unit | Note |
|----------------------|------------------------------------------------|-------------------|------|-------|------|------|
|                      |                                                | Min.              | Typ. | Max.  |      |      |
| Power Supply Voltage | V <sub>CC</sub>                                | 10.8              | 12   | 13.2  | V    | (1)  |
| Rush Current         | I <sub>RUSH</sub>                              | —                 | —    | 3.9   | A    | (2)  |
| Power consumption    | White Pattern                                  | PT                | —    | 4.32  | W    | (3)  |
|                      | Black Pattern                                  | PT                | —    | 2.736 |      |      |
|                      | Heavy Loading pattern<br>Ex: Horizontal Stripe | PT                | —    | 3.888 |      |      |
| Power Supply Current | White Pattern                                  | PT                | —    | 0.36  | A    |      |
|                      | Black Pattern                                  | PT                | —    | 0.228 |      |      |
|                      | Heavy Loading pattern<br>Ex: Horizontal Stripe | PT                | —    | 0.324 |      |      |
| LVDS interface       | Differential Input High Threshold Voltage      | V <sub>LVTH</sub> | +100 | —     | mV   | (4)  |
|                      | Differential Input Low Threshold Voltage       | V <sub>LVTL</sub> | —    | —     | -100 |      |
|                      | Common Input Voltage                           | V <sub>CM</sub>   | 1.0  | 1.2   | 1.4  |      |
|                      | Differential input voltage                     | V <sub>ID</sub>   | 200  | —     | 600  |      |
|                      | Terminating Resistor                           | R <sub>T</sub>    | —    | 100   | —    |      |
| CMOS interface       | Input High Threshold Voltage                   | V <sub>IH</sub>   | 2.7  | —     | V    |      |
|                      | Input Low Threshold Voltage                    | V <sub>IL</sub>   | 0    | —     | V    |      |

Note (1) The module should be always operated within the above ranges.

The ripple voltage should be controlled under 10% of V<sub>CC</sub> (Typ.).

Note (2) Measurement condition :

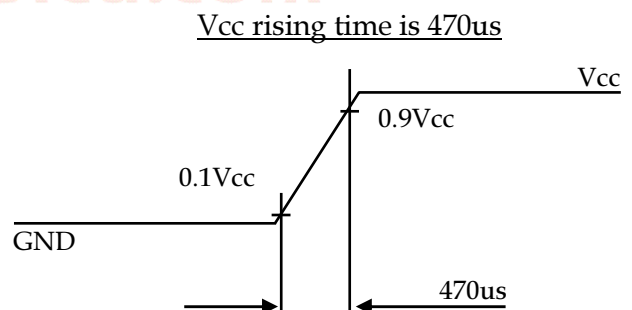
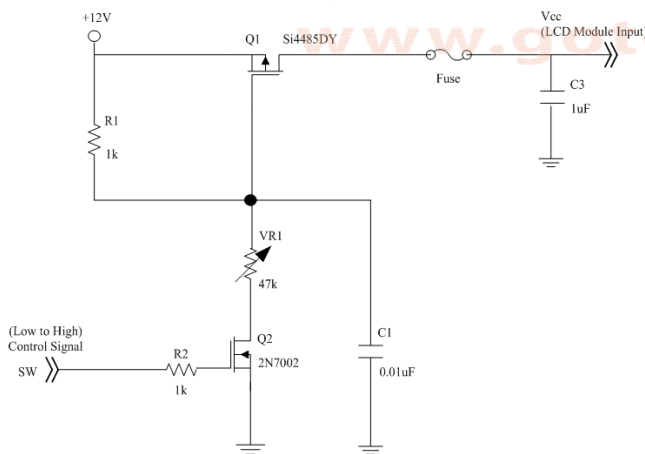

Note (3) The specified power supply current is under the conditions at  $V_{CC} = 12\text{ V}$ ,  $T_a = 25 \pm 2\text{ }^\circ\text{C}$ ,  $f_v = 60\text{ Hz}$ , whereas a power dissipation check pattern below is displayed.

a. White Pattern

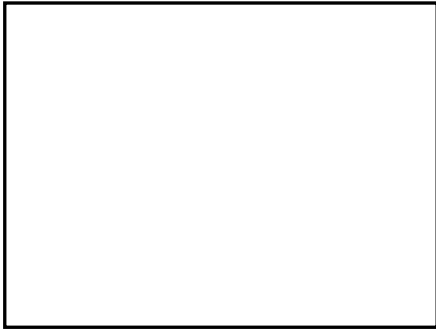

Active Area

b. Black Pattern



Active Area

c. Heavy Loading pattern Ex: Horizontal Stripe

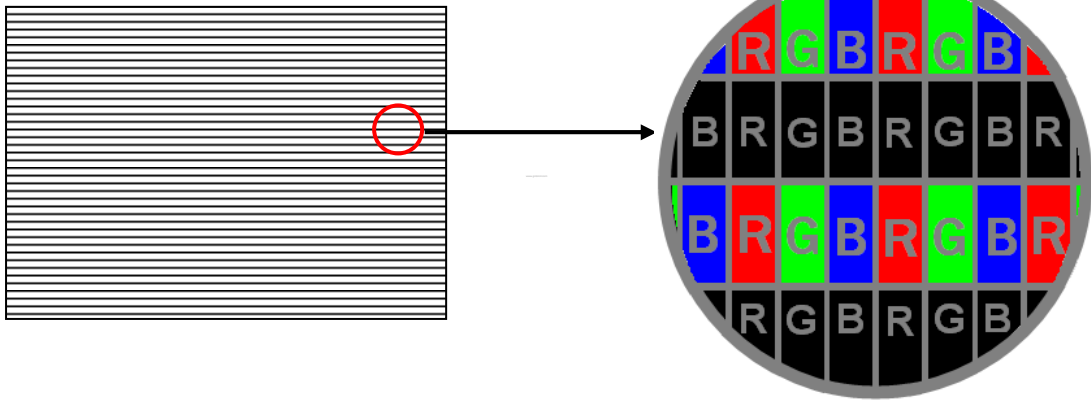

Note (4) The LVDS input characteristics is shown as below :

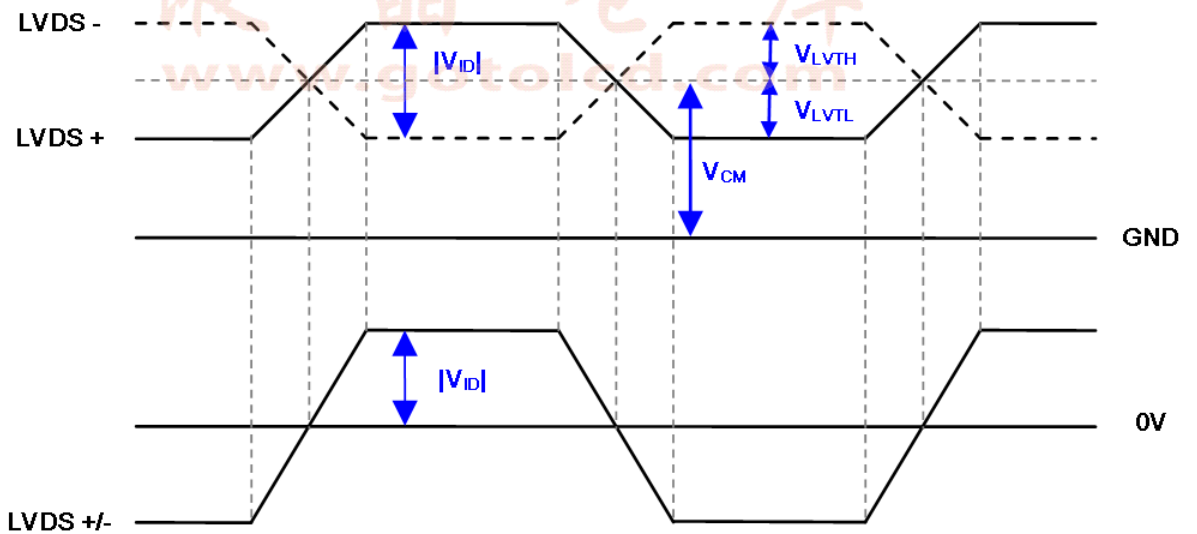

4. INPUT TERMINAL PIN ASSIGNMENT

4.1 TFT LCD OPEN CELL

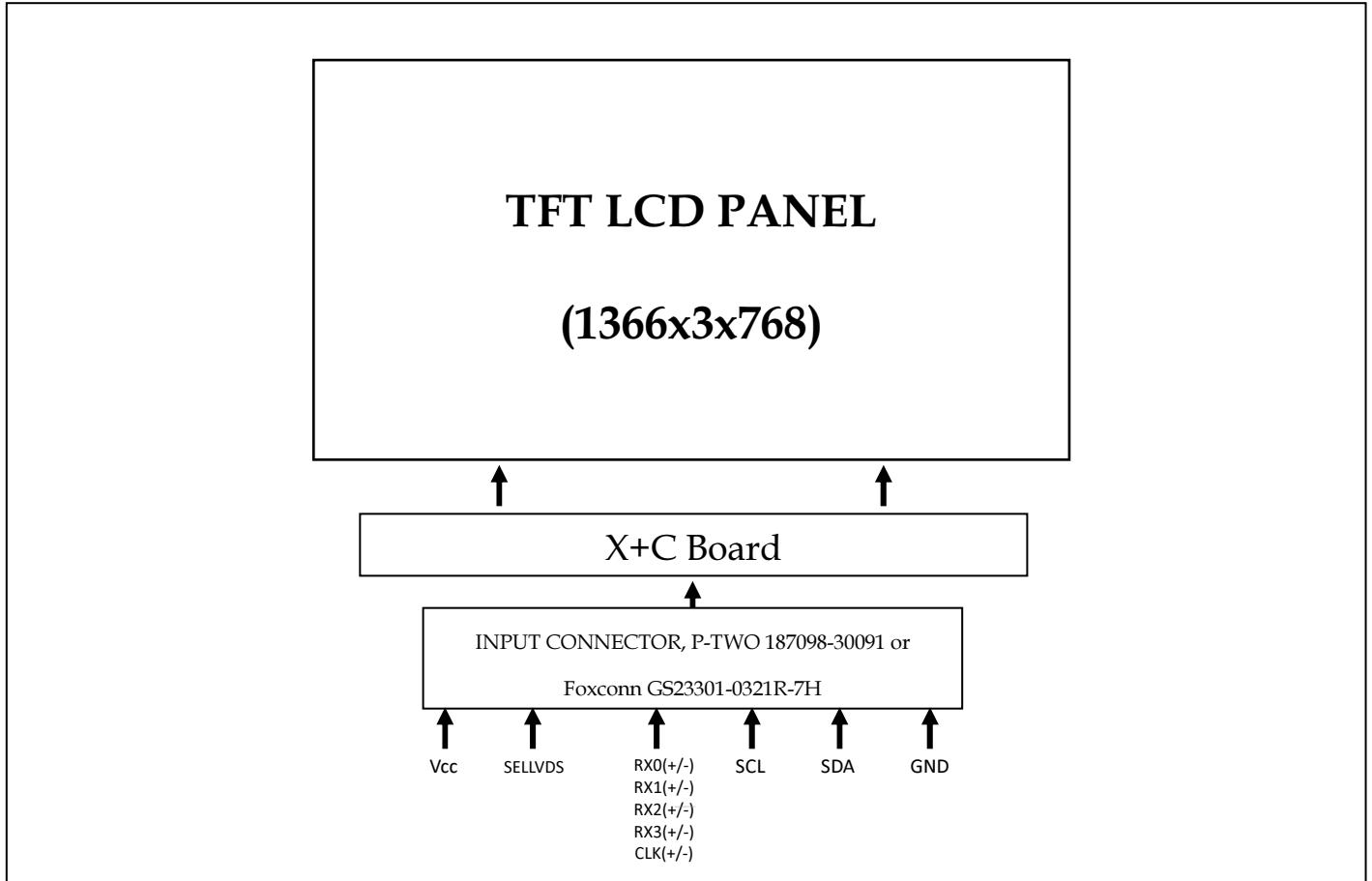

液晶倉庫  
[www.gotolcd.com](http://www.gotolcd.com)

**5. INPUT TERMINAL PIN ASSIGNMENT**

**5.1 TFT LCD OPEN CELL INPUT**

CNF1 Connector Pin Assignment (187098-30091 (P-TWO) , GS23301-0321R-7H (Foxconn))

Matting connector : FI-X30HL (JAE)

| Pin | Name    | Description                           | Note   |
|-----|---------|---------------------------------------|--------|
| 1   | VCC     | Power supply: +12V                    |        |
| 2   | VCC     | Power supply: +12V                    |        |
| 3   | VCC     | Power supply: +12V                    |        |
| 4   | VCC     | Power supply: +12V                    |        |
| 5   | GND     | Ground                                |        |
| 6   | GND     | Ground                                |        |
| 7   | GND     | Ground                                |        |
| 8   | NC      | No Connection                         | (2)    |
| 9   | SELLVDS | LVDS data format Selection            | (3)(4) |
| 10  | NC      | No connection                         | (2)    |
| 11  | GND     | Ground                                |        |
| 12  | RX0-    | Negative transmission data of pixel 0 |        |
| 13  | RX0+    | Positive transmission data of pixel 0 |        |
| 14  | GND     | Ground                                |        |
| 15  | RX1-    | Negative transmission data of pixel 1 |        |
| 16  | RX1+    | Positive transmission data of pixel 1 |        |
| 17  | GND     | Ground                                |        |
| 18  | RX2-    | Negative transmission data of pixel 2 |        |
| 19  | RX2+    | Positive transmission data of pixel 2 |        |
| 20  | GND     | Ground                                |        |
| 21  | RXCLK-  | Negative of clock                     |        |
| 22  | RXCLK+  | Positive of clock                     |        |
| 23  | GND     | Ground                                |        |
| 24  | RX3-    | Negative transmission data of pixel 3 |        |
| 25  | RX3+    | Positive transmission data of pixel 3 |        |
| 26  | GND     | Ground                                |        |
| 27  | NC      | No connection                         | (2)    |
| 28  | SCL     | I2C clock (For Vcom tuning)           |        |
| 29  | SDA     | I2C data (For Vcom tuning)            |        |
| 30  | GND     | Ground                                |        |

Note (1) LVDS connector pin order defined as below

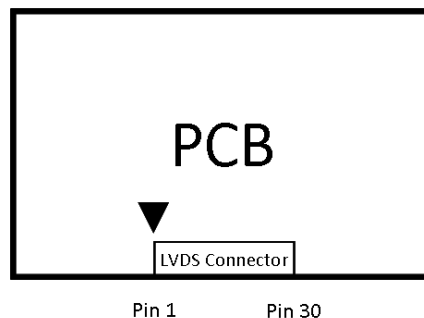

Note (2) Reserved for internal use. Please leave it open.

Note (3) Connect to Open or +3.3V: JEIDA Format, connect to GND: VESA Format.

| SELLVDS    | Mode  |
|------------|-------|
| H(default) | JEIDA |
| L          | VESA  |

L : Connect to GND, H: Connect to +3.3V

Note (4) Interface optional pin has internal scheme as following diagram. Customer should keep the interface voltage level requirement which including Panel board loading as below.

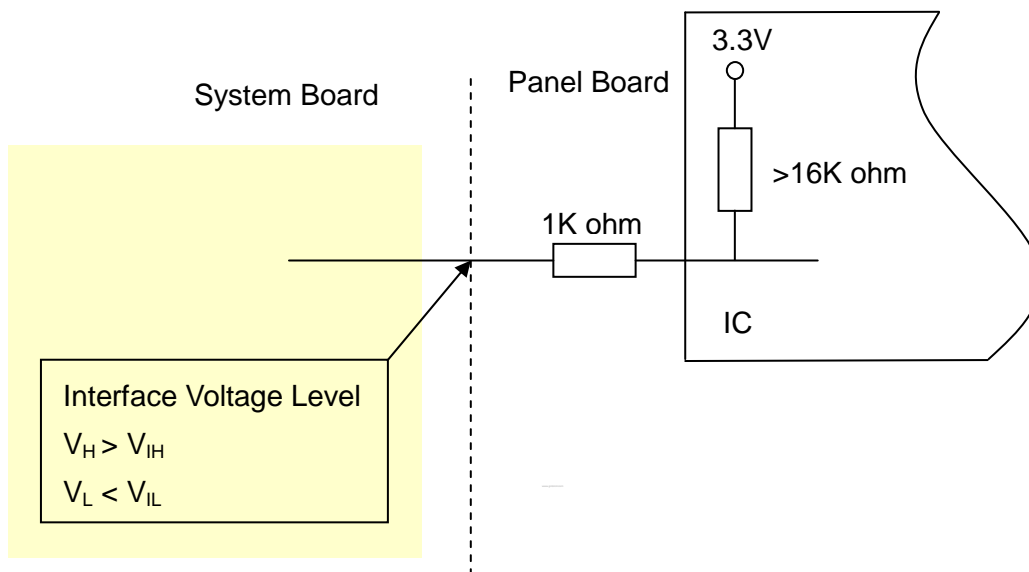

Note (5) LVDS connector mating dimension range request is 0.93mm~1.0mm as below.



Note (6) The screw hole which is distant from the connector is merged with Ground.

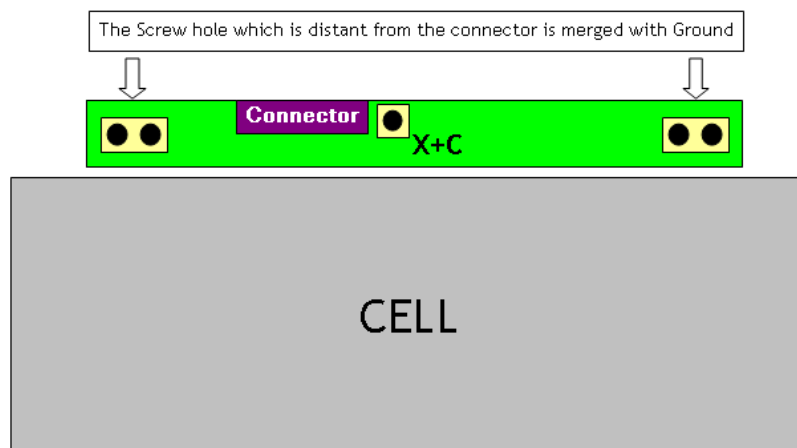

**5.2 LVDS INTERFACE**

JEIDA Format : SELLVDS = H or Open

VESA Format : SELLVDS = L

VESA LVDS format

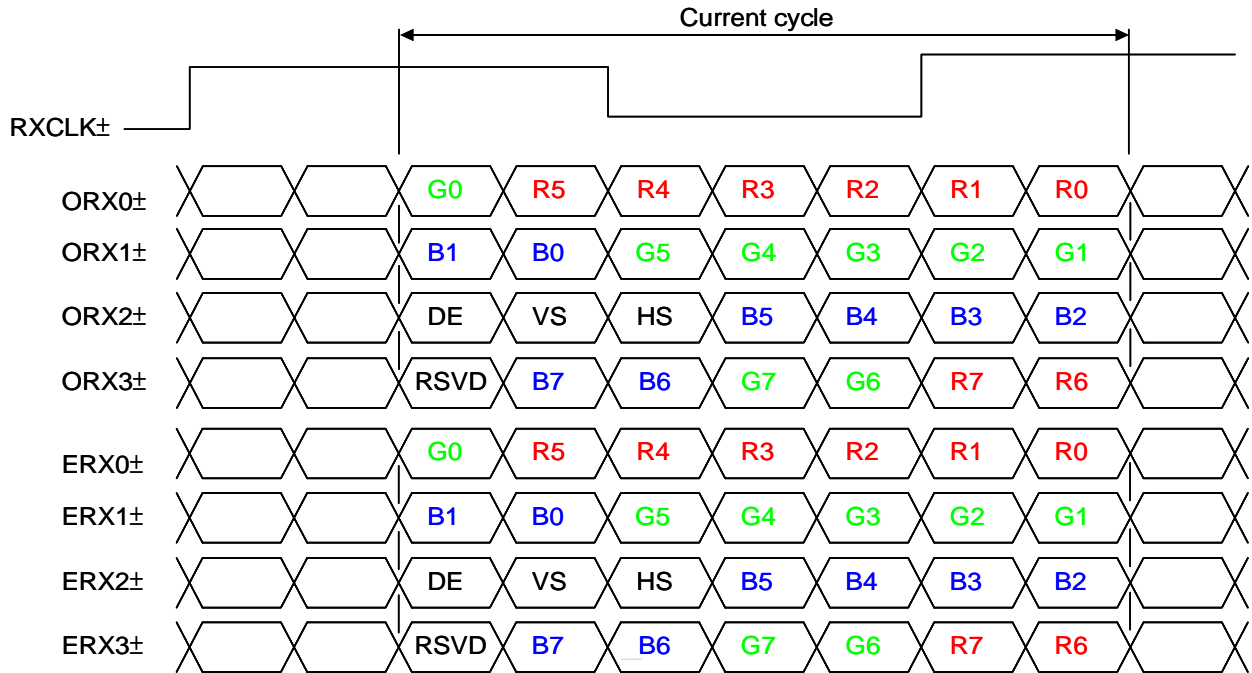

JEDIA LVDS format

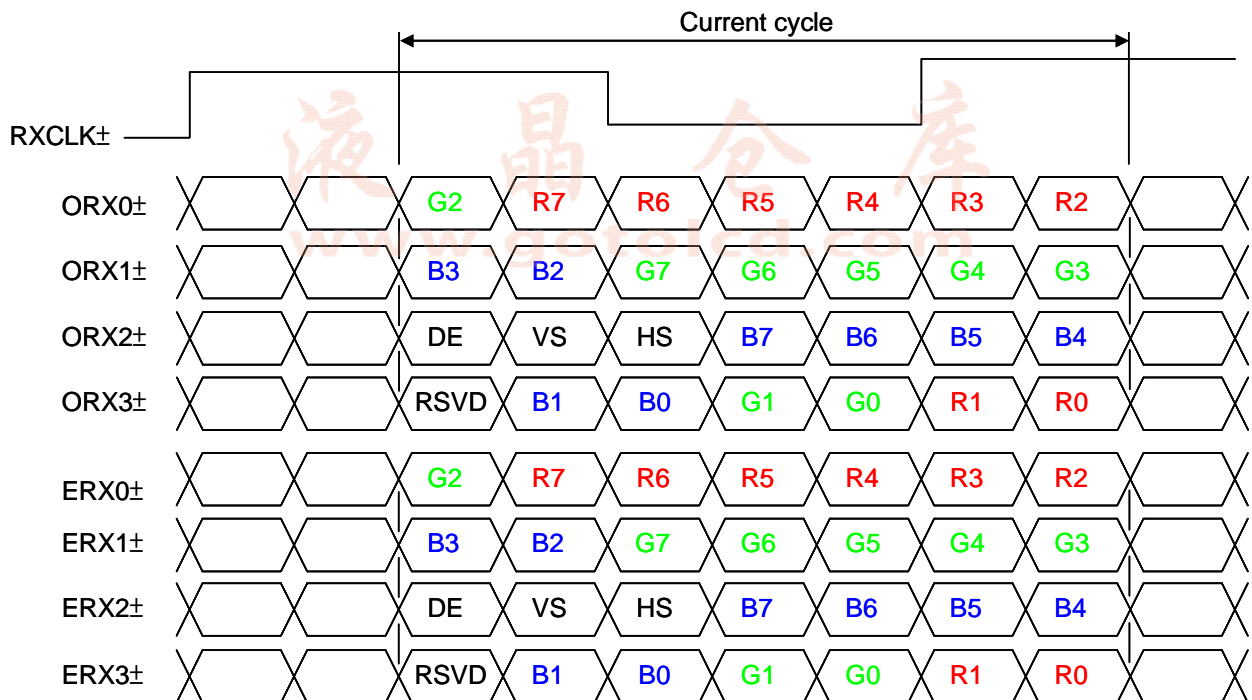

|       |                               |      |                    |
|-------|-------------------------------|------|--------------------|
| R0~R7 | Pixel R Data (7; MSB, 0; LSB) | DE   | Data enable signal |
| G0~G7 | Pixel G Data (7; MSB, 0; LSB) | DCLK | Data clock signal  |
| B0~B7 | Pixel B Data (7; MSB, 0; LSB) |      |                    |

Note (1) RSVD (reserved) pins on the transmitter shall be “H” or “L”.

### 5.3 COLOR DATA INPUT ASSIGNMENT

The brightness of each primary color (red, green and blue) is based on the 8-bit gray scale data input for the color. The higher the binary input, the brighter the color. The table below provides the assignment of the color versus data input.

| Color               |                  | Data Signal |    |    |    |    |    |    |    |       |    |    |    |    |    |    |    |      |    |    |    |    |    |    |
|---------------------|------------------|-------------|----|----|----|----|----|----|----|-------|----|----|----|----|----|----|----|------|----|----|----|----|----|----|
|                     |                  | Red         |    |    |    |    |    |    |    | Green |    |    |    |    |    |    |    | Blue |    |    |    |    |    |    |
|                     |                  | R7          | R6 | R5 | R4 | R3 | R2 | R1 | R0 | G7    | G6 | G5 | G4 | G3 | G2 | G1 | G0 | B7   | B6 | B5 | B4 | B3 | B2 | B1 |
| Basic Colors        | Black            | 0           | 0  | 0  | 0  | 0  | 0  | 0  | 0  | 0     | 0  | 0  | 0  | 0  | 0  | 0  | 0  | 0    | 0  | 0  | 0  | 0  | 0  | 0  |
|                     | Red              | 1           | 1  | 1  | 1  | 1  | 1  | 1  | 1  | 0     | 0  | 0  | 0  | 0  | 0  | 0  | 0  | 0    | 0  | 0  | 0  | 0  | 0  | 0  |
|                     | Green            | 0           | 0  | 0  | 0  | 0  | 0  | 0  | 0  | 1     | 1  | 1  | 1  | 1  | 1  | 1  | 1  | 0    | 0  | 0  | 0  | 0  | 0  | 0  |
|                     | Blue             | 0           | 0  | 0  | 0  | 0  | 0  | 0  | 0  | 0     | 0  | 0  | 0  | 0  | 0  | 0  | 0  | 1    | 1  | 1  | 1  | 1  | 1  | 1  |
|                     | Cyan             | 0           | 0  | 0  | 0  | 0  | 0  | 0  | 0  | 1     | 1  | 1  | 1  | 1  | 1  | 1  | 1  | 1    | 1  | 1  | 1  | 1  | 1  | 1  |
|                     | Magenta          | 1           | 1  | 1  | 1  | 1  | 1  | 1  | 1  | 0     | 0  | 0  | 0  | 0  | 0  | 0  | 0  | 1    | 1  | 1  | 1  | 1  | 1  | 1  |
|                     | Yellow           | 1           | 1  | 1  | 1  | 1  | 1  | 1  | 1  | 1     | 1  | 1  | 1  | 1  | 1  | 1  | 1  | 0    | 0  | 0  | 0  | 0  | 0  | 0  |
|                     | White            | 1           | 1  | 1  | 1  | 1  | 1  | 1  | 1  | 1     | 1  | 1  | 1  | 1  | 1  | 1  | 1  | 1    | 1  | 1  | 1  | 1  | 1  | 1  |
| Gray Scale Of Red   | Red (0) / Dark   | 0           | 0  | 0  | 0  | 0  | 0  | 0  | 0  | 0     | 0  | 0  | 0  | 0  | 0  | 0  | 0  | 0    | 0  | 0  | 0  | 0  | 0  |    |
|                     | Red (1)          | 0           | 0  | 0  | 0  | 0  | 0  | 0  | 1  | 0     | 0  | 0  | 0  | 0  | 0  | 0  | 0  | 0    | 0  | 0  | 0  | 0  | 0  |    |
|                     | Red (2)          | 0           | 0  | 0  | 0  | 0  | 0  | 1  | 0  | 0     | 0  | 0  | 0  | 0  | 0  | 0  | 0  | 0    | 0  | 0  | 0  | 0  | 0  |    |
|                     | ⋮                | ⋮           | ⋮  | ⋮  | ⋮  | ⋮  | ⋮  | ⋮  | ⋮  | ⋮     | ⋮  | ⋮  | ⋮  | ⋮  | ⋮  | ⋮  | ⋮  | ⋮    | ⋮  | ⋮  | ⋮  | ⋮  | ⋮  |    |
|                     | ⋮                | ⋮           | ⋮  | ⋮  | ⋮  | ⋮  | ⋮  | ⋮  | ⋮  | ⋮     | ⋮  | ⋮  | ⋮  | ⋮  | ⋮  | ⋮  | ⋮  | ⋮    | ⋮  | ⋮  | ⋮  | ⋮  | ⋮  |    |
|                     | Red (253)        | 1           | 1  | 1  | 1  | 1  | 1  | 0  | 1  | 0     | 0  | 0  | 0  | 0  | 0  | 0  | 0  | 0    | 0  | 0  | 0  | 0  | 0  |    |
|                     | Red (254)        | 1           | 1  | 1  | 1  | 1  | 1  | 1  | 0  | 0     | 0  | 0  | 0  | 0  | 0  | 0  | 0  | 0    | 0  | 0  | 0  | 0  | 0  |    |
|                     | Red (255)        | 1           | 1  | 1  | 1  | 1  | 1  | 1  | 1  | 0     | 0  | 0  | 0  | 0  | 0  | 0  | 0  | 0    | 0  | 0  | 0  | 0  | 0  |    |
| Gray Scale Of Green | Green (0) / Dark | 0           | 0  | 0  | 0  | 0  | 0  | 0  | 0  | 0     | 0  | 0  | 0  | 0  | 0  | 0  | 0  | 0    | 0  | 0  | 0  | 0  | 0  |    |
|                     | Green (1)        | 0           | 0  | 0  | 0  | 0  | 0  | 0  | 0  | 0     | 0  | 0  | 0  | 0  | 0  | 0  | 1  | 0    | 0  | 0  | 0  | 0  | 0  |    |
|                     | Green (2)        | 0           | 0  | 0  | 0  | 0  | 0  | 0  | 0  | 0     | 0  | 0  | 0  | 0  | 0  | 1  | 0  | 0    | 0  | 0  | 0  | 0  | 0  |    |
|                     | ⋮                | ⋮           | ⋮  | ⋮  | ⋮  | ⋮  | ⋮  | ⋮  | ⋮  | ⋮     | ⋮  | ⋮  | ⋮  | ⋮  | ⋮  | ⋮  | ⋮  | ⋮    | ⋮  | ⋮  | ⋮  | ⋮  | ⋮  |    |
|                     | ⋮                | ⋮           | ⋮  | ⋮  | ⋮  | ⋮  | ⋮  | ⋮  | ⋮  | ⋮     | ⋮  | ⋮  | ⋮  | ⋮  | ⋮  | ⋮  | ⋮  | ⋮    | ⋮  | ⋮  | ⋮  | ⋮  | ⋮  |    |
|                     | Green (253)      | 0           | 0  | 0  | 0  | 0  | 0  | 0  | 0  | 1     | 1  | 1  | 1  | 1  | 1  | 0  | 1  | 0    | 0  | 0  | 0  | 0  | 0  |    |
|                     | Green (254)      | 0           | 0  | 0  | 0  | 0  | 0  | 0  | 0  | 1     | 1  | 1  | 1  | 1  | 1  | 1  | 0  | 0    | 0  | 0  | 0  | 0  | 0  |    |
|                     | Green (255)      | 0           | 0  | 0  | 0  | 0  | 0  | 0  | 0  | 1     | 1  | 1  | 1  | 1  | 1  | 1  | 1  | 0    | 0  | 0  | 0  | 0  | 0  |    |
| Gray Scale Of Blue  | Blue (0) / Dark  | 0           | 0  | 0  | 0  | 0  | 0  | 0  | 0  | 0     | 0  | 0  | 0  | 0  | 0  | 0  | 0  | 0    | 0  | 0  | 0  | 0  | 0  |    |
|                     | Blue (1)         | 0           | 0  | 0  | 0  | 0  | 0  | 0  | 0  | 0     | 0  | 0  | 0  | 0  | 0  | 0  | 0  | 0    | 0  | 0  | 0  | 0  | 1  |    |
|                     | Blue (2)         | 0           | 0  | 0  | 0  | 0  | 0  | 0  | 0  | 0     | 0  | 0  | 0  | 0  | 0  | 0  | 0  | 0    | 0  | 0  | 0  | 0  | 1  |    |
|                     | ⋮                | ⋮           | ⋮  | ⋮  | ⋮  | ⋮  | ⋮  | ⋮  | ⋮  | ⋮     | ⋮  | ⋮  | ⋮  | ⋮  | ⋮  | ⋮  | ⋮  | ⋮    | ⋮  | ⋮  | ⋮  | ⋮  | ⋮  |    |
|                     | ⋮                | ⋮           | ⋮  | ⋮  | ⋮  | ⋮  | ⋮  | ⋮  | ⋮  | ⋮     | ⋮  | ⋮  | ⋮  | ⋮  | ⋮  | ⋮  | ⋮  | ⋮    | ⋮  | ⋮  | ⋮  | ⋮  | ⋮  |    |
|                     | Blue (253)       | 0           | 0  | 0  | 0  | 0  | 0  | 0  | 0  | 0     | 0  | 0  | 0  | 0  | 0  | 0  | 0  | 1    | 1  | 1  | 1  | 1  | 1  |    |
|                     | Blue (254)       | 0           | 0  | 0  | 0  | 0  | 0  | 0  | 0  | 0     | 0  | 0  | 0  | 0  | 0  | 0  | 0  | 1    | 1  | 1  | 1  | 1  | 1  |    |
|                     | Blue (255)       | 0           | 0  | 0  | 0  | 0  | 0  | 0  | 0  | 0     | 0  | 0  | 0  | 0  | 0  | 0  | 0  | 1    | 1  | 1  | 1  | 1  | 1  |    |

Note (1) 0: Low Level Voltage, 1: High Level Voltage

#### 5.4 FLICKER (Vcom) ADJUSTMENT

(1) Adjustment Pattern :

The adjustment pattern is shown as below. If customer needs below pattern, please directly contact with INX account FAE.

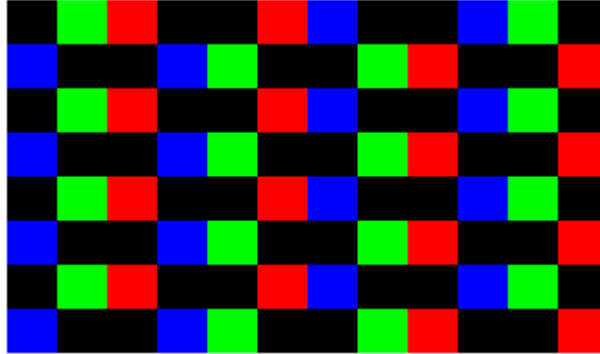

(2) Adjustment method: (Digital V-com)

Programmable memory IC is used for Digital V-com adjustment in this model. INX provide Auto Vcom tools to adjust Digital V-com. The detail connection and setting instruction, please directly contact with Account FAE or refer INX Auto V-com adjustment OI. Below items is suggested to be ready before Digital V-com adjustment in customer LCM line.

- a. USB Sensor Board.
- b. Programmable software.
- c. Document: Auto V-com adjustment suggestion OI.

液晶倉庫  
www.gotolcd.com



**6. INTERFACE TIMING**

**6.1 INPUT SIGNAL TIMING SPECIFICATIONS**

The input signal timing specifications are shown as the following table and timing diagram.

| Signal                         | Item                                 | Symbol                    | Min.               | Typ. | Max.               | Unit | Note                |
|--------------------------------|--------------------------------------|---------------------------|--------------------|------|--------------------|------|---------------------|
| LVDS Receiver Clock            | Frequency                            | $F_{clk_{in}}$<br>(=1/TC) | 60                 | 76   | 82                 | MHz  |                     |
|                                | Input cycle to cycle jitter          | $T_{rcl}$                 | —                  | —    | 200                | ps   | (3)                 |
|                                | Spread spectrum modulation range     | $F_{clk_{in\_mod}}$       | $F_{clk_{in}}-2\%$ | —    | $F_{clk_{in}}+2\%$ | MHz  | (4)                 |
|                                | Spread spectrum modulation frequency | $F_{SSM}$                 | —                  | —    | 200                | KHz  |                     |
| LVDS Receiver Data             | Receiver Skew Margin                 | $T_{RSKM}$                | -400               | —    | 400                | ps   | (5)                 |
| Vertical Active Display Term   | Frame Rate                           | $F_{r5}$                  | 47                 | 50   | 53                 | Hz   | (6)                 |
|                                |                                      | $F_{r6}$                  | 57                 | 60   | 63                 | Hz   |                     |
|                                | Total                                | $T_v$                     | 778                | 806  | 986                | Th   | $T_v=T_{vd}+T_{vb}$ |
|                                | Display                              | $T_{vd}$                  | 768                | 768  | 768                | Th   | —                   |
|                                | Blank                                | $T_{vb}$                  | 10                 | 38   | 218                | Th   | —                   |
| Horizontal Active Display Term | Total                                | $T_h$                     | 1446               | 1560 | 1936               | Tc   | $T_h=T_{hd}+T_{hb}$ |
|                                | Display                              | $T_{hd}$                  | 1366               | 1366 | 1366               | Tc   | —                   |
|                                | Blank                                | $T_{hb}$                  | 80                 | 194  | 570                | Tc   | —                   |

Note (1) Please make sure the range of pixel clock has follow the below equation :

$$F_{clk_{in}}(\max) \geq F_{r6} \times T_v \times T_h$$

$$F_{r5} \times T_v \times T_h \geq F_{clk_{in}}(\min)$$

Note (2) This module is operated in DE only mode and please follow the input signal timing diagram below :

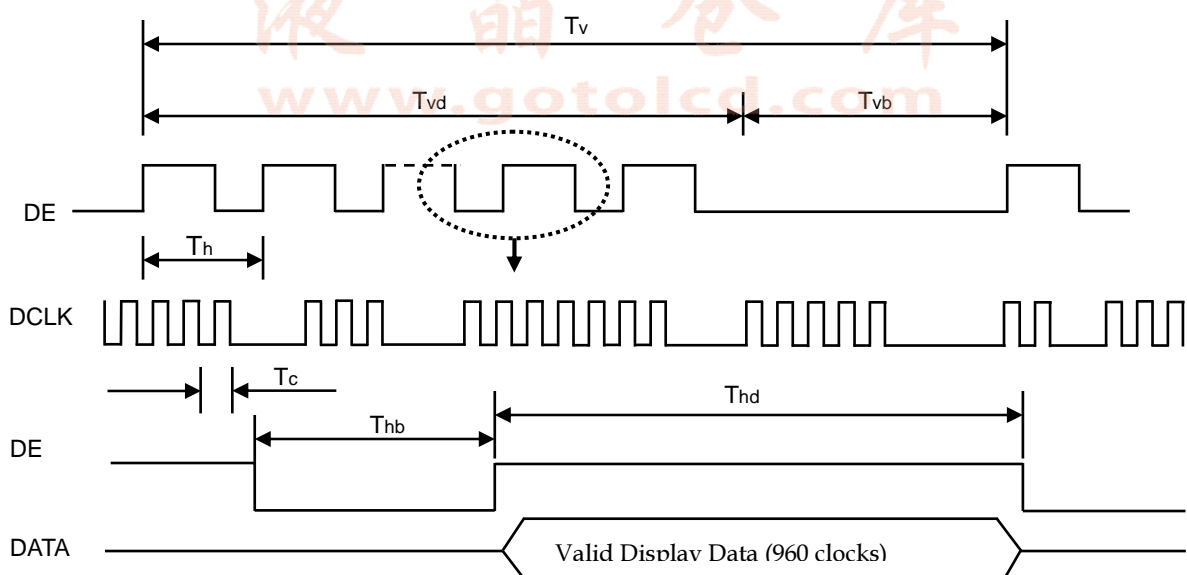

Note (3) The input clock cycle-to-cycle jitter is defined as below figures.  $Trcl = |T_1 - T|$

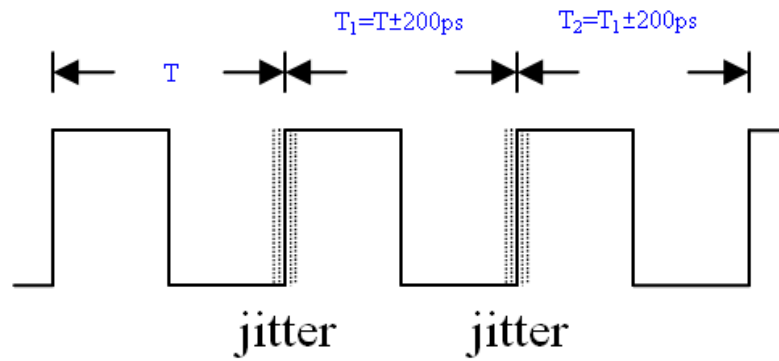

Note (4) The SSCG (Spread spectrum clock generator) is defined as below figures.

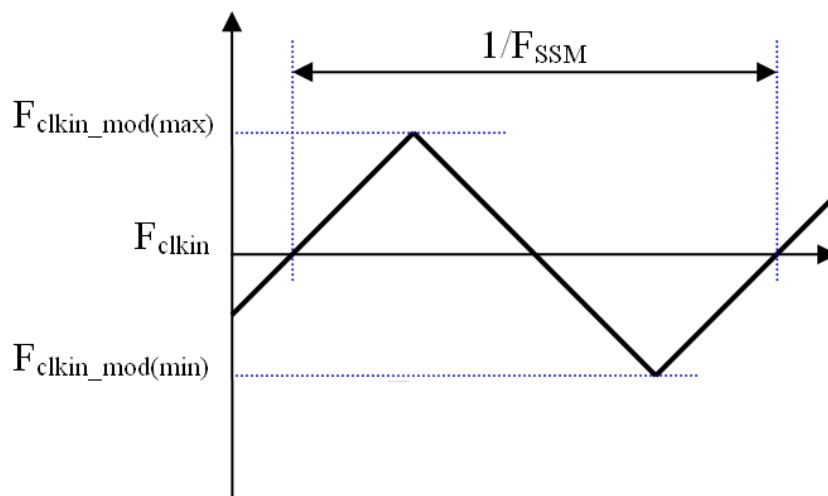

Note (5) The LVDS timing diagram and the receiver skew margin is defined and shown in following figure.

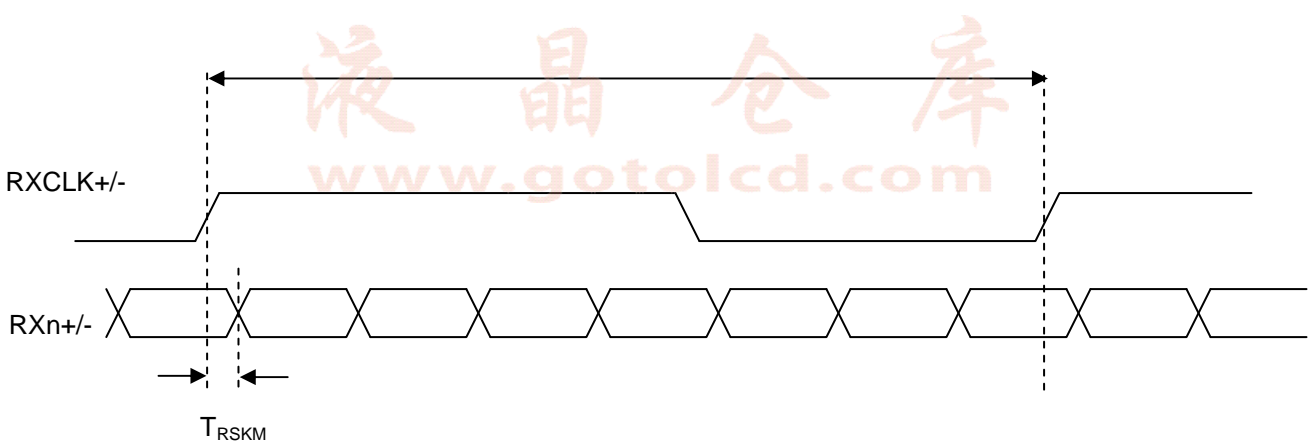

**6.2 POWER ON/OFF SEQUENCE**

To prevent a latch-up or DC operation of LCD module, the power on/off sequence should be as the diagram below.

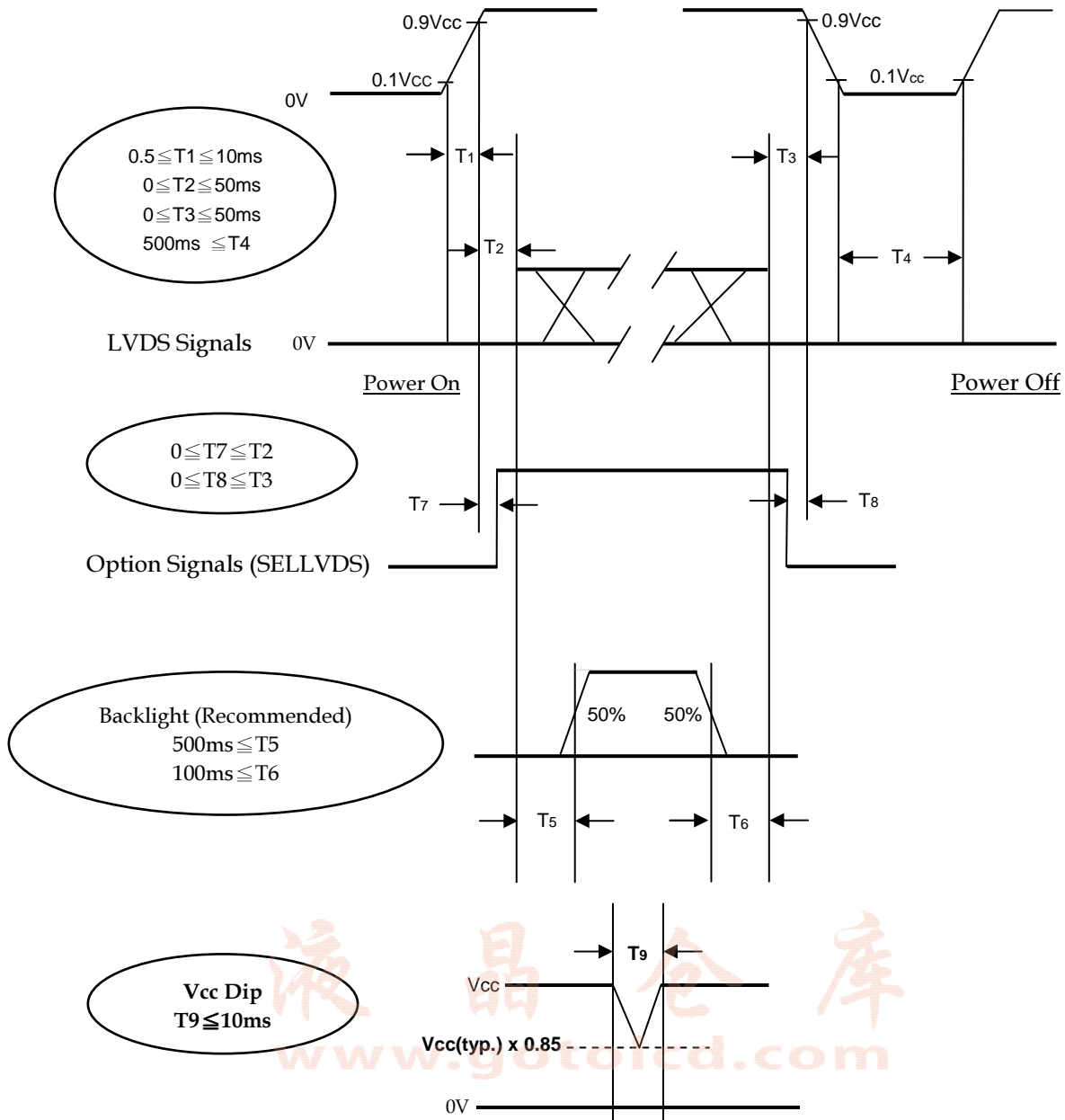

- Note (1) The supply voltage of the external system for the module input should follow the definition of V<sub>CC</sub>.
- Note (2) Apply the lamp voltage within the LCD operation range. When the backlight turns on before the LCD operation or the LCD turns off before the backlight turns off, the display may momentarily become abnormal screen.
- Note (3) In case of V<sub>CC</sub> is in off level, please keep the level of input signals on the low or high impedance.  
If T<sub>2</sub><0, that maybe cause electrical overstress failure.
- Note (4) T<sub>4</sub> should be measured after the module has been fully discharged between power off and on period.
- Note (5) Interface signal shall not be kept at high impedance when the power is on.
- Note (6) V<sub>CC</sub> must decay smoothly when power-off.

**7. OPTICAL CHARACTERISTICS**

**7.1 TEST CONDITIONS**

| Item                | Symbol                                                        | Value     | Unit |
|---------------------|---------------------------------------------------------------|-----------|------|
| Ambient Temperature | Ta                                                            | 25 ±2     | °C   |
| Ambient Humidity    | Ha                                                            | 50 ±10    | %RH  |
| Vertical Frame Rate | Fr                                                            | 60        | Hz   |
| Supply Voltage      | V <sub>CC</sub>                                               | 12.0 ±1.2 | V    |
| Input Signal        | According to typical value in "3. ELECTRICAL CHARACTERISTICS" |           |      |

The LCD module should be stabilized at given temperature for 1 hour to avoid abrupt temperature change during measuring in a windless room.

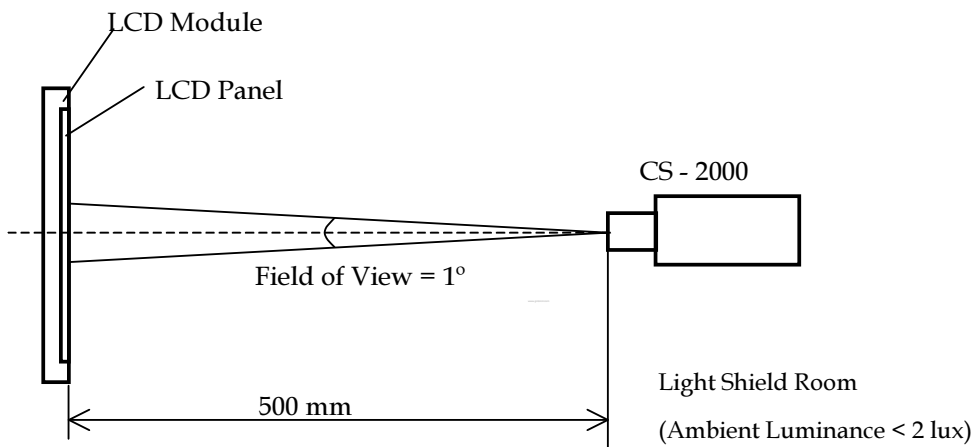

液晶倉庫  
www.gotolcd.com

**7.2 OPTICAL SPECIFICATIONS**

The relative measurement methods of optical characteristics are shown as below. The following items should be measured under the test conditions described in 7.1 and stable environment shown in 7.1.

| Item                    |            | Symbol        | Condition                                                                                              | Min.  | Typ.  | Max.  | Unit | Note    |         |
|-------------------------|------------|---------------|--------------------------------------------------------------------------------------------------------|-------|-------|-------|------|---------|---------|
| Color Chromaticity      | Red        | Rcx           | $\theta_x=0^\circ, \theta_y=0^\circ$<br>Viewing Angle at Normal Direction<br>Standard light source "C" | -0.03 | 0.658 | +0.03 | -    | (0)     |         |
|                         |            | Rcy           |                                                                                                        |       | 0.325 |       | -    |         |         |
|                         | Green      | Gcx           |                                                                                                        |       | 0.277 |       | -    |         |         |
|                         |            | Gcy           |                                                                                                        |       | 0.583 |       | -    |         |         |
|                         | Blue       | Bcx           |                                                                                                        |       | 0.136 |       | -    |         |         |
|                         |            | Bcy           |                                                                                                        |       | 0.104 |       | -    |         |         |
|                         | White      | Wcx           |                                                                                                        |       | 0.310 |       | -    |         |         |
|                         |            | Wcy           |                                                                                                        |       | 0.350 |       | -    |         |         |
| Transmittance           |            | T%            | $\theta_x=0^\circ, \theta_y=0^\circ$<br>With INX Module@60Hz                                           | -     | 5.6   | -     | %    | (5)     |         |
| Transmittance Variation |            | $\delta T$    |                                                                                                        |       |       | 1.42  |      |         | (6)     |
| Contrast Ratio          |            | CR            |                                                                                                        | 2000  | 3000  | -     | -    |         | (1),(3) |
| Response Time           |            | Gray to gray  | $\theta_x=0^\circ, \theta_y=0^\circ$<br>With INX Module@60Hz                                           | -     | 8.5   | 20    | ms   | (1),(4) |         |
| Viewing Angle           | Horizontal | $\theta_{x+}$ | CR $\geq$ 20<br>With INX Module                                                                        |       | 88    | -     | Deg. | (1),(2) |         |
|                         |            | $\theta_{x-}$ |                                                                                                        |       | 88    | -     |      |         |         |
|                         | Vertical   | $\theta_{y+}$ |                                                                                                        |       | 88    | -     |      |         |         |
|                         |            | $\theta_{y-}$ |                                                                                                        |       | 88    | -     |      |         |         |

Note (0) Light source is the standard light source "C" which is defined by CIE and driving voltage are based on

suitable gamma voltages. The calculating method is as following :

- 1.Measure Module's and BLU's spectrum at center point. W, R,G, B are with signal input. BLU (V236BJ1-LE2) is supplied by INX.
- 2.Calculate cell's spectrum.
- 3.Calculate cell's chromaticity by using the spectrum of standard light source "C".

Note (1) Light source is the BLU which supplied by INX (V236BJ1-LE2) and the cell driving voltage are based on suitable gamma voltages.

Note (2) Definition of Viewing Angle ( $\theta_x, \theta_y$ ) :

Viewing angles are measured by Autronic Conoscope Cono-80 (or Eldim EZ-Contrast 160R)

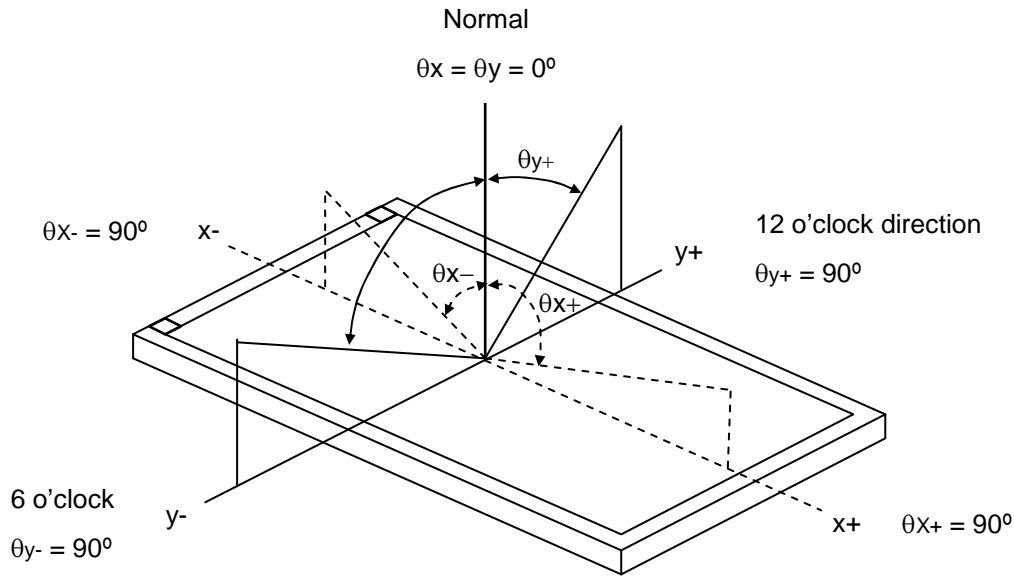

Note (3) Definition of Contrast Ratio (CR) :

The contrast ratio can be calculated by the following expression.

$$\text{Contrast Ratio (CR)} = \frac{\text{Surface Luminance of L255}}{\text{Surface Luminance of L0}}$$

L255: Luminance of gray level 255

L 0: Luminance of gray level 0

CR = CR (X), where CR (X) is corresponding to the Contrast Ratio of the point X at the figure in Note (6).

Note (4) Definition of Gray-to-Gray Switching Time :

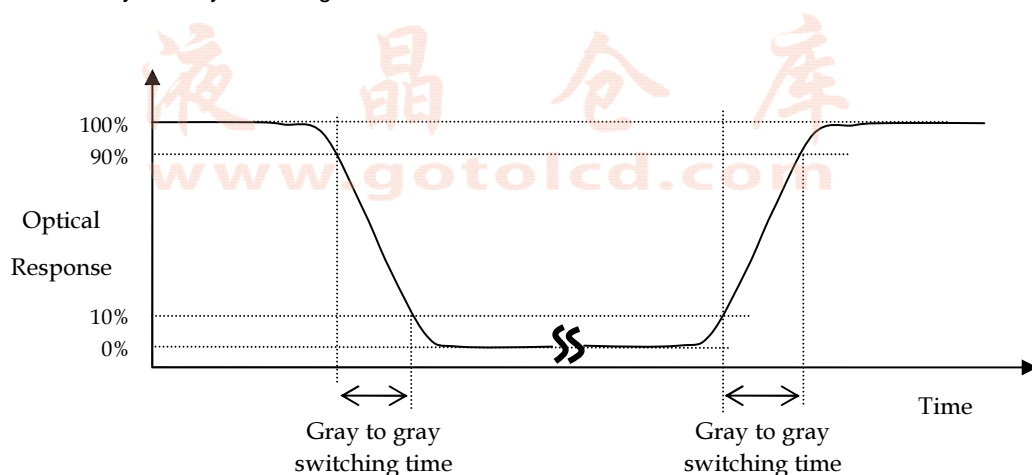

The driving signal means the signal of gray level 0, 31, 63, 95, 127, 159, 191, 223 and 255.

Gray to gray average time means the average switching time of gray level 0, 31, 63, 95, 127, 159, 191, 223 and 255 to each other.

Note (5) Definition of Transmittance (T%) :

Measure the transmittance at 5 points.

Light source is the BLU which contains three diffuser sheets and the cell driving voltage are based on suitable gamma voltages.

$$\text{Transmittance (T\%)} = \text{Average} [T(1), T(2), T(3), T(4), T(5)]$$

The transmittance of each point can be calculated by the following expression.

$$T(X) = \frac{\text{L1023 (X) of LCD module}}{\text{Luminance (X) of BLU}} \times 100\%$$

L1023: Luminance of gray level 1023

T(X) is corresponding to the point X1~X5 at the figure in Note (6).

Note (6) Definition of Transmittance Variation ( $\delta T$ ) :

Measure the transmittance at 5 points.

$$\text{Transmittance Variation } (\delta T) = \frac{\text{Maximum} [T(1), T(2), T(3), T(4), T(5)]}{\text{Minimum} [T(1), T(2), T(3), T(4), T(5)]}$$

T(X) is calculated as Note(5).

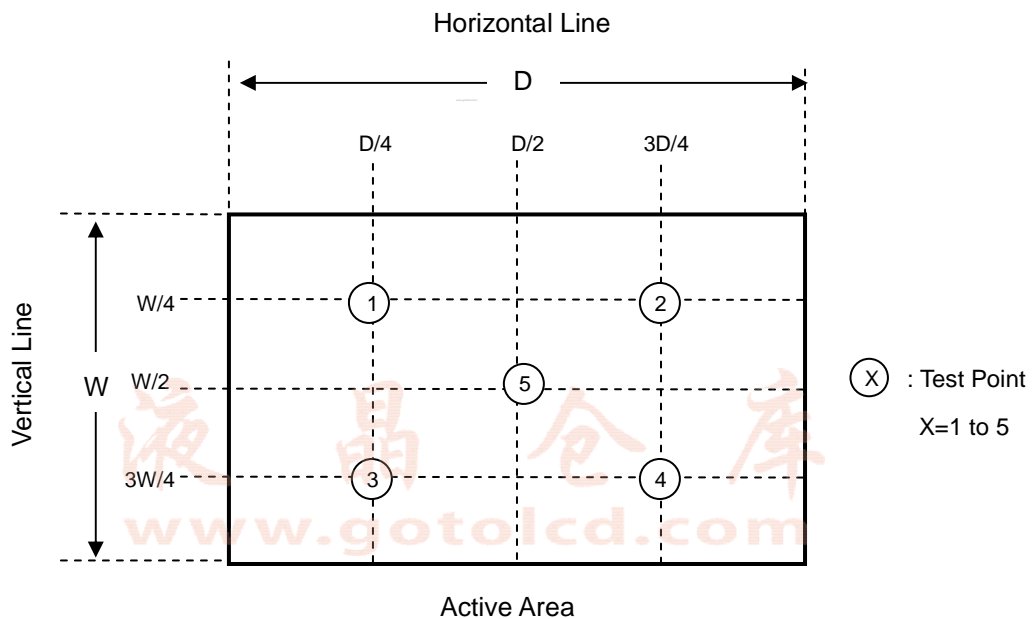

## 8. PRECAUTIONS

### 8.1 ASSEMBLY AND HANDLING PRECAUTIONS

- [ 1 ] Do not apply improper or unbalanced force such as bending or twisting to open cells during assembly.
- [ 2 ] It is recommended to assemble or to install an open cell into a customer's product in clean working areas. The dust and oil may cause electrical short to an open cell or worsen polarizers on an open cell.
- [ 3 ] Do not apply pressure or impulse to an open cell to prevent the damage.
- [ 4 ] Always follow the correct power-on sequence when an open cell is assembled and turned on. This can prevent the damage and latch-up of the CMOS LSI chips.
- [ 5 ] Do not design sharp-pointed structure / parting line / tooling gate on the plastic part of a COF (Chip on film), because the burr will scrape the COF.
- [ 6 ] If COF would be bended in assemble process, do not place IC on the bending corner.
- [ 7 ] The gap between COF IC and any structure of BLU must be bigger than 2 mm. This can prevent the damage of COF IC.
- [ 8 ] The bezel opening must have no burr and be smooth to prevent the surface of an open cell scraped.
- [ 9 ] The bezel of a module or a TV set can not contact with force on the surface of an open cell. It might cause light leakage or scrape.
- [ 10 ] In the case of no FFC or FPC attached with open cells, customers can refer the FFC / FPC drawing and buy them by self.
- [ 11 ] It is important to keep enough clearance between customers' front bezel/backlight and an open cell. Without enough clearance, the unexpected force during module assembly procedure may damage an open cell.
- [ 12 ] Do not plug in or unplug an I/F (interface) connector while an assembled open cell is in operation.
- [ 13 ] Use a soft dry cloth without chemicals for cleaning, because the surface of the polarizer is very soft and easily scratched.
- [ 14 ] Moisture can easily penetrate into an open cell and may cause the damage during operation.
- [ 15 ] When storing open cells as spares for a long time, the following precaution is necessary.
  - [ 15.1 ] Do not leave open cells in high temperature and high humidity for a long time. It is highly recommended to store open cells in the temperature range from 0 to 35°C at normal humidity without condensation.
  - [ 15.2 ] Open cells shall be stored in dark place. Do not store open cells in direct sunlight or fluorescent light environment.
- [ 16 ] When ambient temperature is lower than 10°C, the display quality might be reduced.
- [ 17 ] Unpacking (Cartons/Tray plates) in order to prevent open cells broken:
  - [ 17.1 ] Moving tray plates by one operator may cause tray plates bent which may induce open cells broken. Two operators carry one carton with their two hands. Do not throw cartons/tray plates, avoid any impact on cartons/tray plates, and put down & pile cartons/tray plates gently.
  - [ 17.2 ] A tray plate handled with unbalanced force may cause an open cell damaged. Trays should be completely put on a flat platform.
  - [ 17.3 ] To prevent open cells broken, tray plates should be moved one by one from a plastic bag.



- [ 17.4 ] Please follow the packing design instruction, such as the maximum number of tray stacking to prevent the deformation of tray plates which may cause open cells broken.
- [ 17.5 ] To prevent an open cell broken or a COF damaged on a tray, please follow the instructions below:
  - [17.5.1] Do not peel a polarizer protection film of an open cell off on a tray
  - [17.5.2] Do not install FFC or LVDS cables of an open cell on a tray
  - [17.5.3] Do not press the surface of an open cell on a tray.
  - [17.5.4] Do not pull X-board when an open cell placed on a tray.
- [ 18 ] Unpacking (Hard Box) in order to prevent open cells broken:
  - [ 18.1 ] Moving hard boxes by one operator may cause hard boxes fell down and open cells broken by abnormal methods. Two operators carry one hard box with their two hands. Do handle hard boxes carefully, such as avoiding impact, putting down, and piling up gently.
  - [ 18.2 ] To prevent hard boxes sliding from carts and falling down, hard boxes should be placed on a surface with resistance.
  - [ 18.3 ] To prevent an open cell broken or a COF damaged in a hard box, please follow the instructions below:
    - [18.3.1] Do not peel a polarizer protection film of an open cell off in a hard box.
    - [18.3.2] Do not install FFC or LVDS cables of an open cell in a hard box.
    - [18.3.3] Do not press the surface of an open cell in a hard box.
    - [18.3.4] Do not pull X-board when an open cell placed in a hard box.
- [ 19 ] Handling – In order to prevent open cells, COFs , and components damaged:
  - [ 19.1 ] The forced displacement between open cells and X-board may cause a COF damaged. Use a fixture tool for handling an open cell to avoid X-board vibrating and interfering with other components on a PCBA & a COF.
  - [ 19.2 ] To prevent open cells and COFs damaged by taking out from hard boxes, using vacuum jigs to take out open cells horizontally is recommended.
  - [ 19.3 ] Improper installation procedure may cause COFs of an open cell over bent which causes damages. As installing an open cell on a backlight or a test jig, place the bottom side of the open cell first on the backlight or the test jig and make sure no interference before fitting the open cell into the backlight/the test jig.
  - [ 19.4 ] Handle open cells one by one.
- [ 20 ] Avoid any metal or conductive material to contact PCB components, because it could cause electrical damage or defect.

## 8.2 SAFETY PRECAUTIONS

- [ 1 ] If the liquid crystal material leaks from the open cell, it should be kept away from the eyes or mouth. In case of contact with hands, skin or clothes, it has to be washed away thoroughly with soap.
- [ 2 ] After the end of life, open cells are not harmful in case of normal operation and storage.

**9. DEFINITION OF LABELS**

**9.1 OPEN CELL LABEL**

The barcode nameplate is pasted on each open cell as illustration for INX internal control.

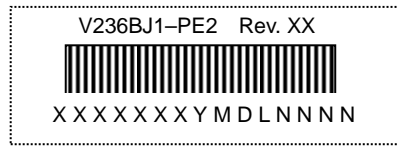
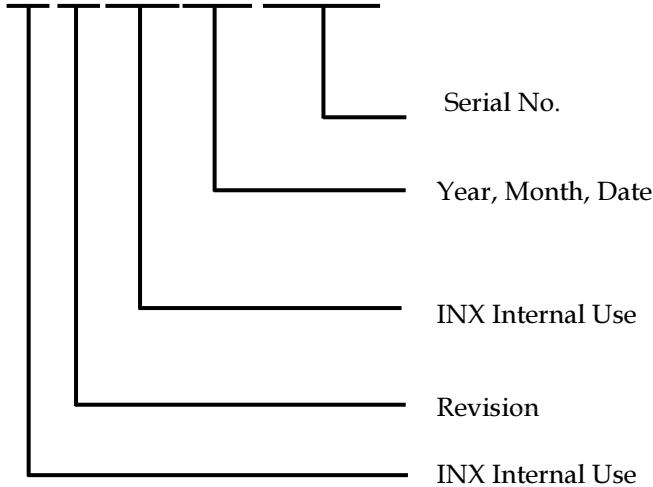

Figure.9-1 Serial No. Label on SPWB and Cell

Model Name : V236BJ1-PE2

Revision : Rev. XX, for example: A0, A1... B1, B2... or C1, C2...etc.

Serial ID : XXXXXXXYMDLNNNN



Serial ID includes the information as below:

Manufactured Date:

Year: 2010=0, 2011=1,2012=2...etc.

Month: 1~9, A~C, for Jan. ~ Dec.

Day: 1~9, A~Y, for 1st to 31st, exclude I ,O, and U.

Revision Code: Cover all the change

Serial No.: Manufacturing sequence of product

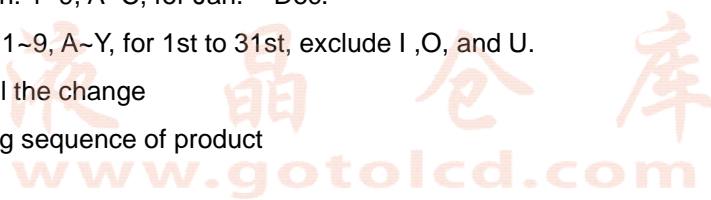

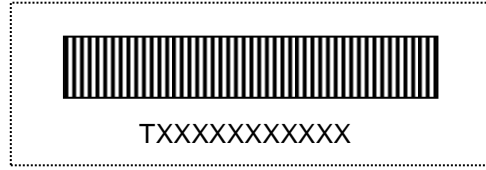
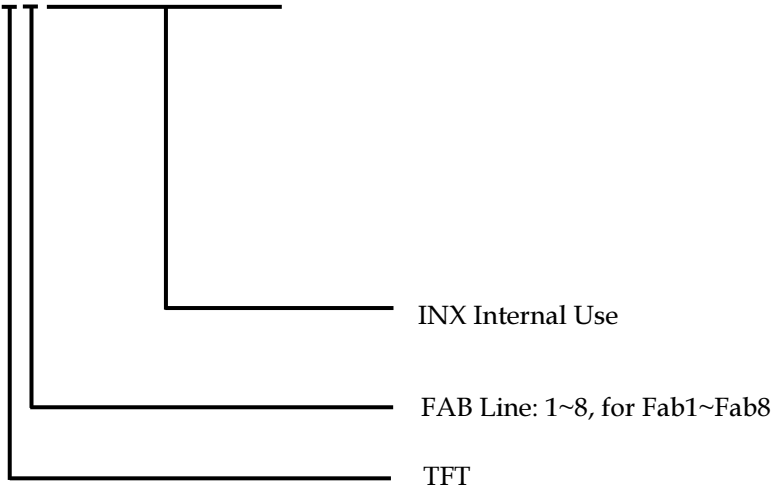

Figure.9-2 Panel ID Label on Cell

Panel ID Label includes the information as below :

Panel ID: T X X X X X X X X X X



液晶仓库  
www.gotolcd.com

**10. PACKAGING**

**10.1 PACKAGING SPECIFICATIONS**

- (1) 20 PCS LCD TV Panels / 1 Box
- (2) Box dimensions: 630 (L) X 445 (W) X 130.5 (H) mm
- (3) Weight: approximately 12.2 Kg
- (4) 720 PCS LCD TV Panels / 1 Group
- (5) Without the outer carton, Boxes stack under the package architecture.

**10.2 PACKAGING METHOD**

Packing method (Hard Box) is shown in following figures.

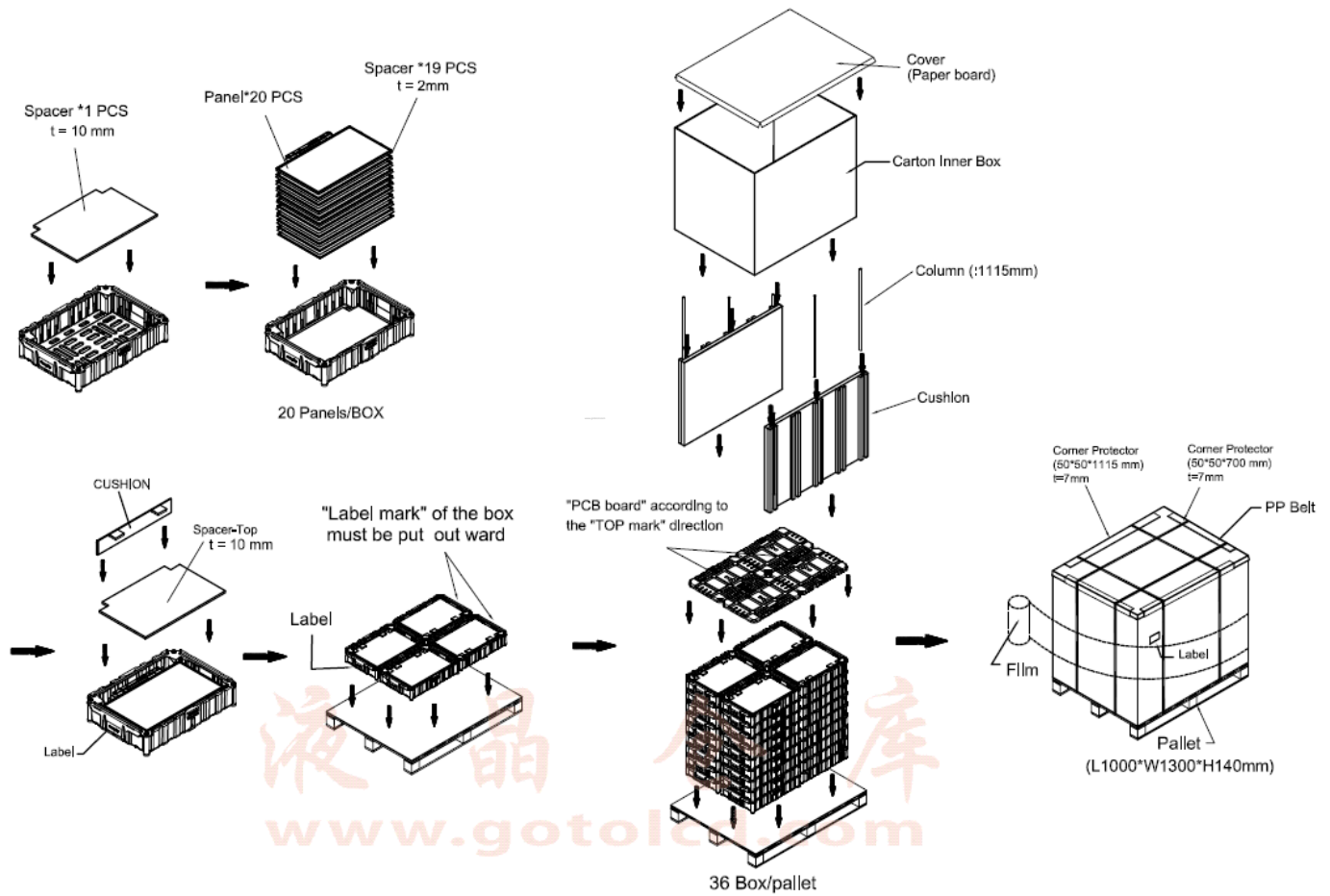
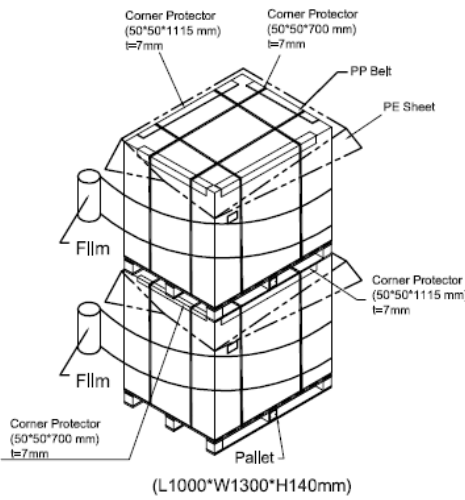

Figure.10-1 packing method

Sea / Land Transportation  
(40ft HQ Container)

Sea / Land Transportation

Air Transportation



36 Box / Pallet +36 Box / Pallet

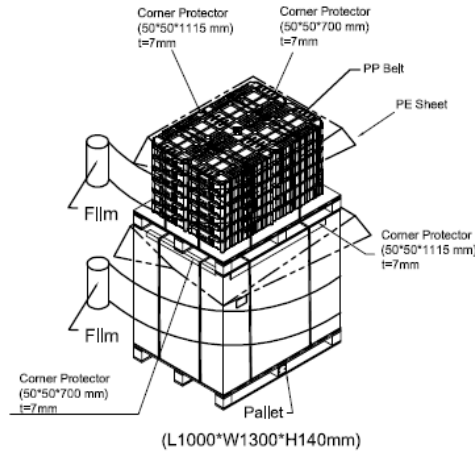

24 Box / Pallet +36 Box / Pallet

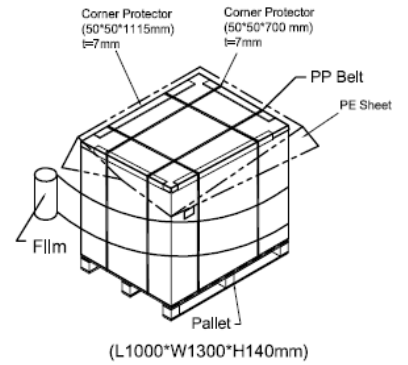

36 Box / Pallet

Figure.10-2 packing method

### 10.3 UNPACKING METHOD

Unpacking method (Hard Box) is shown in following figures.

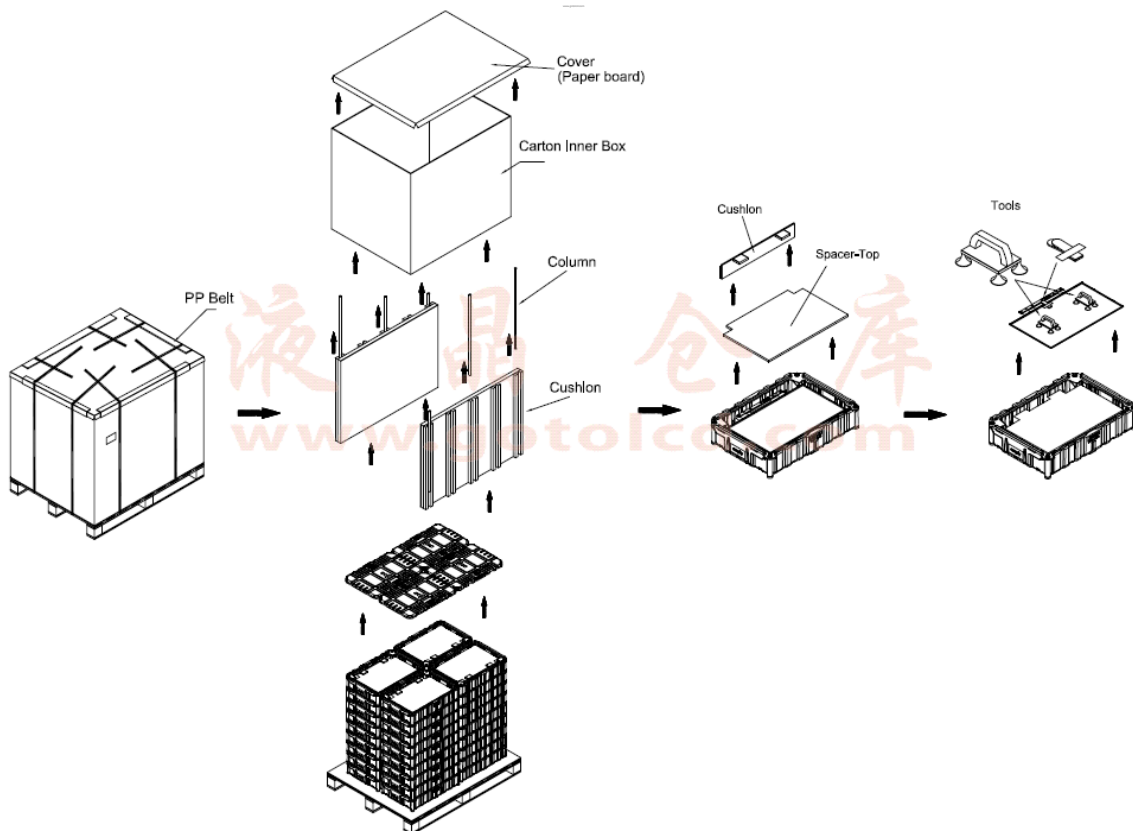
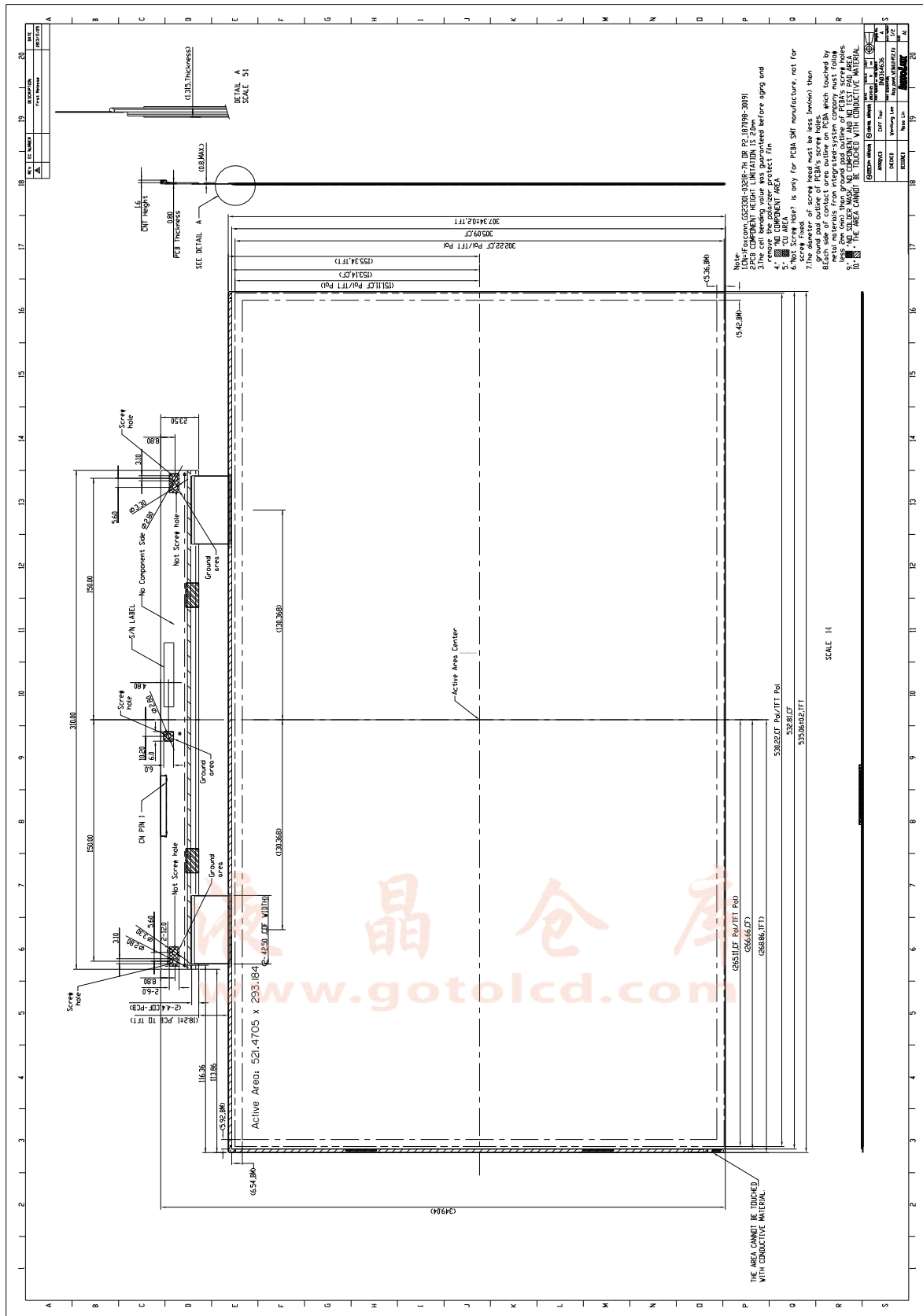
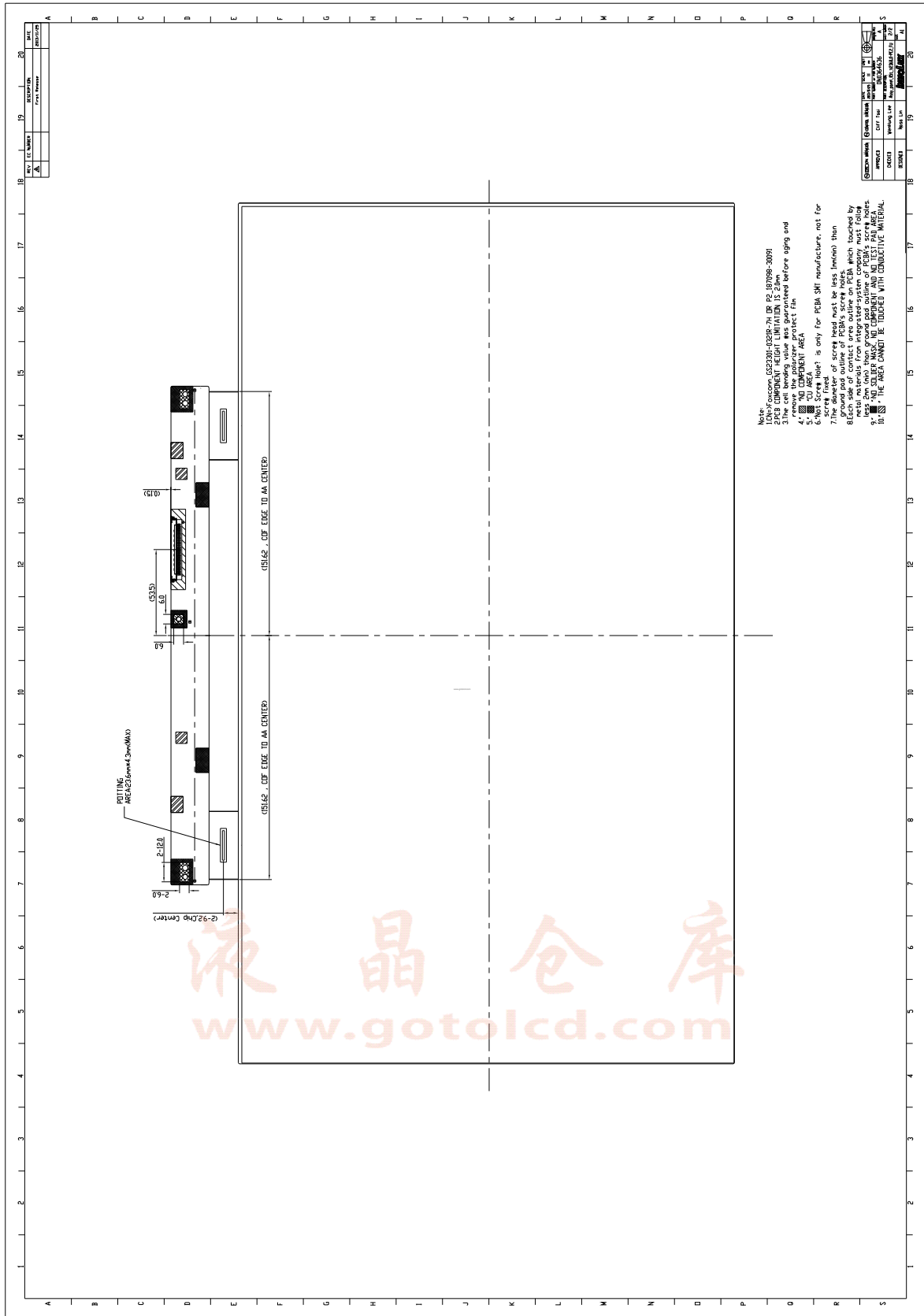

Figure.10.3 unpacking method

11. MECHANICAL CHARACTERISTIC





Note:  
 1. Use of Concom. GS83301-02PR-7H DR P2.1817088-20091  
 2. PCB COMPONENT HEIGHT LIMITATION IS 2.5mm.  
 3. Remove the potting compound before signs and  
 4. Use of Concom. GS83301-02PR-7H DR P2.1817088-20091  
 5. Use of Concom. GS83301-02PR-7H DR P2.1817088-20091  
 6. NOT Screw Hole? is only for PCB MFG manufacturer, not for  
 7. The diameter of screw head must be less than (width) than  
 8. ground pad outline of PCB's screw holes.  
 9. The diameter of screw head must be less than (width) than  
 10. The diameter of screw head must be less than (width) than  
 11. The diameter of screw head must be less than (width) than  
 12. The diameter of screw head must be less than (width) than  
 13. The diameter of screw head must be less than (width) than  
 14. The diameter of screw head must be less than (width) than  
 15. The diameter of screw head must be less than (width) than  
 16. The diameter of screw head must be less than (width) than  
 17. The diameter of screw head must be less than (width) than  
 18. The diameter of screw head must be less than (width) than  
 19. The diameter of screw head must be less than (width) than  
 20. The diameter of screw head must be less than (width) than

| REV | LC NUMBER | DESCRIPTION | DATE |
|-----|-----------|-------------|------|
| 1   |           |             |      |
| 2   |           |             |      |
| 3   |           |             |      |
| 4   |           |             |      |
| 5   |           |             |      |
| 6   |           |             |      |
| 7   |           |             |      |
| 8   |           |             |      |
| 9   |           |             |      |
| 10  |           |             |      |
| 11  |           |             |      |
| 12  |           |             |      |
| 13  |           |             |      |
| 14  |           |             |      |
| 15  |           |             |      |
| 16  |           |             |      |
| 17  |           |             |      |
| 18  |           |             |      |
| 19  |           |             |      |
| 20  |           |             |      |

www.gotolcd.com