

- Tentative Specification
- Preliminary Specification
- Approval Specification

**MODEL NO.: V236H1**  
**SUFFIX: LE6**

<b>Customer:</b>	
<b>APPROVED BY</b>	<b>SIGNATURE</b>
Name / Title _____	_____
<b>Note</b>	
<hr/> Please return 1 copy for your confirmation with your signature and comments.	

Approved By	Checked By	Prepared By
Chao-Chun Chung	Roger Huang	Bowei Huang

## CONTENTS

1. GENERAL DESCRIPTION.....	5
1.1 OVERVIEW.....	5
1.2 FEATURES.....	5
1.3 APPLICATION.....	5
1.4 GENERAL SPECIFICATIONS.....	5
1.5 MECHANICAL SPECIFICATIONS.....	6
2. ABSOLUTE MAXIMUM RATINGS.....	7
2.1 ABSOLUTE RATINGS OF ENVIRONMENT.....	7
2.2 PACKAGE STORAGE.....	8
2.3 ELECTRICAL ABSOLUTE RATINGS.....	8
2.3.1 TFT LCD MODULE.....	8
2.3.2 BACKLIGHT CONVERTER UNIT.....	8
3. ELECTRICAL CHARACTERISTICS.....	9
3.1 TFT LCD MODULE.....	9
3.2 BACKLIGHT CONNECTOR PIN CONFIGURATION.....	11
3.2.1 LED LIGHT BAR CHARACTERISTICS.....	11
3.2.2 LIGHTBAR CONNECTOR PIN ASSIGNMENT.....	12
3.3 LVDS INPUT SIGNAL SPECIFICATIONS.....	12
4. BLOCK DIAGRAM OF INTERFACE.....	13
4.1 TFT LCD MODULE.....	13
5. INPUT TERMINAL PIN ASSIGNMENT.....	14
5.1 TFT LCD MODULE INPUT.....	14
5.3 BLOCK DIAGRAM OF INTERFACE.....	16
5.4 LVDS INTERFACE.....	17
5.5 COLOR DATA INPUT ASSIGNMENT.....	18
6. INTERFACE TIMING.....	19
6.1 INPUT SIGNAL TIMING SPECIFICATIONS.....	19
6.2 POWER ON/OFF SEQUENCE.....	21
7. OPTICAL CHARACTERISTICS.....	22
7.1 TEST CONDITIONS.....	22
7.2 OPTICAL SPECIFICATIONS.....	23

8. PRECAUTIONS .....	27
8.1 ASSEMBLY AND HANDLING PRECAUTIONS .....	27
8.2 SAFETY PRECAUTIONS .....	27
8.3 SAFETY REVIEW .....	27
8.3.1 SAFETY STANDARDS .....	27
9. DEFINITION OF LABELS.....	28
9.1 CMI MODULE LABEL.....	28
10. PACKAGING .....	29
10.1 PACKING SPECIFICATIONS.....	29
10.2 PACKAGING METHOD .....	29
11. MECHANICAL CHARACTERISTIC.....	31

## REVISION HISTORY

Version	Date	Page(New)	Section	Description
Ver. 2.0	Jan. 05, 2012	All	All	The Approval specification was first issued.

## 1. GENERAL DESCRIPTION

### 1.1 OVERVIEW

V236H1-LE6 is a 23.6" TFT Liquid Crystal Display module with WLED Backlight unit and 30 pins 2ch-LVDS interface. This module supports 1920 x 1080 Full HDTV format and can display up to 16.7M (6 bit +Hi-FRC) colors. The converter module for Backlight is not built in.

### 1.2 FEATURES

- Extra-wide viewing angle.
- High contrast ratio.
- Fast response time.
- High color saturation.
- Full HD (1920 x 1080 pixels) resolution.
- DE (Data Enable) only mode.
- LVDS (Low Voltage Differential Signaling) interface.
- RoHS compliance.

### 1.3 APPLICATION

- Standard Living Room TVs
- MFM Application

### 1.4 GENERAL SPECIFICATIONS

Item	Specification	Unit	Note
Active Area	521.28H) x 293.22(V) (23.547" diagonal)	mm	(1)
Bezel Opening Area	525.22 (H) x 297.22 (V)	mm	
Driver Element	a-si TFT active matrix	-	-
Pixel Number	1920 x R.G.B. x 1080	pixel	-
Pixel Pitch(Sub Pixel)	0.2715(H) x 0.2715(V)	mm	-
Pixel Arrangement	RGB vertical stripe	-	-
Power consumption	19.26W (Max.) [Cell PW 6.0W (Max.) + BLU PW 13.26W (Max.)]	Watt	(2)
Display Colors	16.7M (6 bit +Hi-FRC)	color	-
Display Operation Mode	Transmissive mode / Normally white	-	-
Surface Treatment	Anti-Glare coating (Haze 25%)	-	

Note (1) Please refer to the attached drawings in chapter 9 for more information about the front and back outlines.

Note (2) Please refer sec 3.1 and 3.2 for more information of Power consumption

**1.5 MECHANICAL SPECIFICATIONS**

Item		Min.	Typ.	Max.	Unit	Note
Module Size	Horizontal (H)	544.3	544.8	545.3	mm	(1)
	Vertical (V)	320.0	320.5	321.0	mm	(1)
	Depth (D)	-	11.0	11.5	mm	(1)
Weight		-	2300	-	g	-

Note (1) Please refer to the attached drawings for more information of front and back outline dimensions.

## 2. ABSOLUTE MAXIMUM RATINGS

### 2.1 ABSOLUTE RATINGS OF ENVIRONMENT

Item	Symbol	Value		Unit	Note
		Min.	Max.		
Storage Temperature	TST	-20	+60	°C	(1)
Operating Ambient Temperature	TOP	0	50	°C	(1), (2)
Shock (Non-Operating)	SNOP	-	50	G	(3), (5)
Vibration (Non-Operating)	VNOP	-	1.0	G	(4), (5)

Note (1) Temperature and relative humidity range is shown in the figure below.

- (a) 90 %RH Max. ( $T_a \leq 40$  °C).
- (b) Wet-bulb temperature should be 39 °C Max. ( $T_a > 40$  °C).
- (c) No condensation.

Note (2) The maximum operating temperature is based on the test condition that the surface temperature of display area is less than or equal to 65 °C with LCD module alone in a temperature controlled chamber. Thermal management should be considered in final product design to prevent the surface temperature of display area from being over 65 °C. The range of operating temperature may degrade in case of improper thermal management in final product design.

Note (3) 11 ms, half sine wave, 1 time for  $\pm X$ ,  $\pm Y$ ,  $\pm Z$ .

Note (4) 10 ~ 200 Hz, 10 min, 1 time each X, Y, Z.

Note (5) At testing Vibration and Shock, the fixture in holding the module has to be hard and rigid enough so that the module would not be twisted or bent by the fixture.

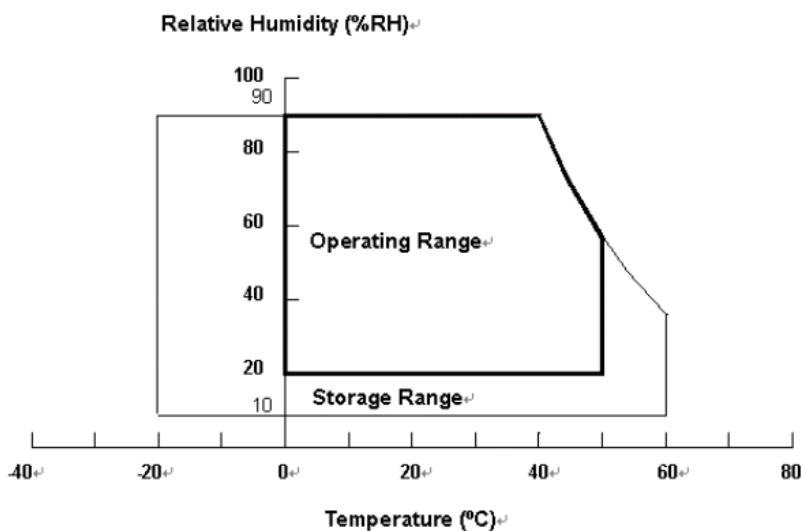

## 2.2 PACKAGE STORAGE

When storing modules as spares for a long time, the following precaution is necessary.

- (a) Do not leave the module in high temperature, and high humidity for a long time, It is highly recommended to store the module with temperature from 0 to 35 °C at normal humidity without condensation.
- (b) The module shall be stored in dark place. Do not store the TFT-LCD module in direct sunlight or fluorescent light.

## 2.3 ELECTRICAL ABSOLUTE RATINGS

### 2.3.1 TFT LCD MODULE

Item	Symbol	Value		Unit	Note
		Min.	Max.		
Power Supply Voltage	VCC	-0.3	+6	V	(1)
Logic Input Voltage	VIN	-0.3	3.6	V	

### 2.3.2 BACKLIGHT CONVERTER UNIT

Item	Symbol	Value			Unit	Note
		Min.	Typ.	Max.		
LED Forward Current Per Input Pin	I <sub>F</sub>	0	65	69	mA	(1) (2) Duty=100%
LED Pulse Forward Current Per Input Pin	I <sub>FP</sub>	—	—	150	mA	Pulse Width ≤ 10msec. and Duty ≤ 30%

Note (1) Permanent damage to the device may occur if maximum values are exceeded. Function operation should be restricted to the conditions described under Normal Operating Conditions.

Note (2) Specified values are for input pin of LED light bar at Ta=25±2 °C (Refer to 3.2 for further information).



## 3. ELECTRICAL CHARACTERISTICS

### 3.1 TFT LCD MODULE

(Ta = 25 ± 2 °C)

Parameter	Symbol	Value			Unit	Note	
		Min.	Typ.	Max.			
Power Supply Voltage	V <sub>CC</sub>	4.5	5.0	5.5	V	(1)	
Rush Current	I <sub>RUSH</sub>	—	1.52	3	A	(2)	
Power Consumption	P <sub>T</sub>	—	5.2	6	W	(3)	
Power Supply Current	White Pattern	—	0.41	0.43	A	(4)	
	Vertical Stripe	—	0.94	1.03	A		
	Black Pattern	—	1.04	1.2	A		
LVDS interface	Differential Input High Threshold Voltage	V <sub>TH</sub>	—	—	+100	mV	(5)
	Differential Input Low Threshold Voltage	V <sub>TL</sub>	-100	—	—	mV	
	Common Input Voltage	V <sub>CM</sub>	1.0	1.2	1.4	V	
	Differential input voltage	V <sub>ID</sub>	200	—	600	mV	
	Terminating Resistor	R <sub>T</sub>	—	100	—	ohm	
CMOS interface	Logic High Input Voltage	V <sub>IH</sub>	2.64	-	3.6	V	
	Logic Low Input Voltage	V <sub>IL</sub>	0	-	0.66	V	

Note (1) The module should be always operated within the above ranges.

Note (2) Measurement condition:

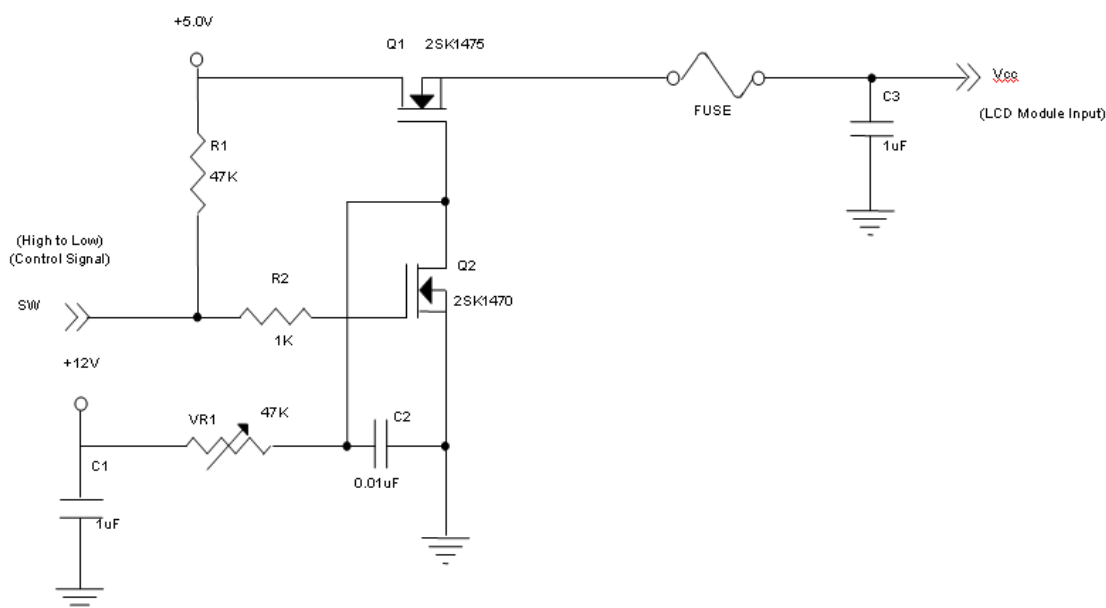

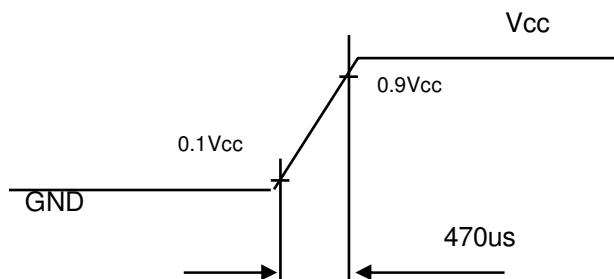
**Vcc rising time is 470us**

Note (3) The Specified Power consumption is under Vertical Stripe pattern.

Note (4) The specified Max. power supply current is under the conditions at  $V_{cc}=5.0V$ ,  $T_a = 25 \pm 2 \text{ }^\circ\text{C}$ ,  $f_v = 75 \text{ Hz}$ , whereas a power dissipation check pattern below is displayed.

a. White Pattern

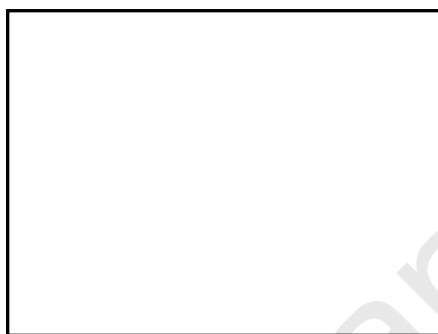

Active Area

b. Black Pattern

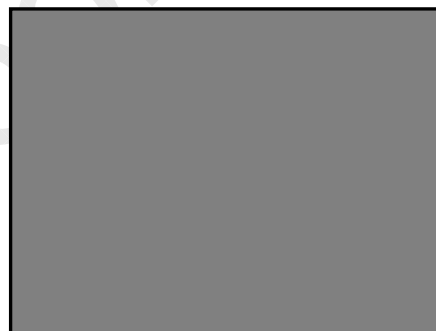

Active Area

c. Vertical Stripe Pattern

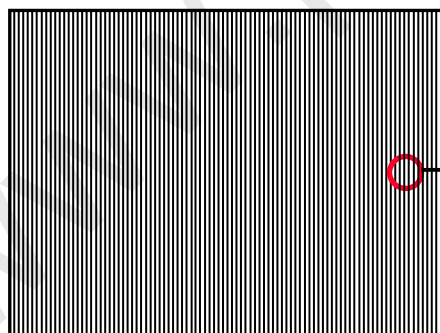

Active Area

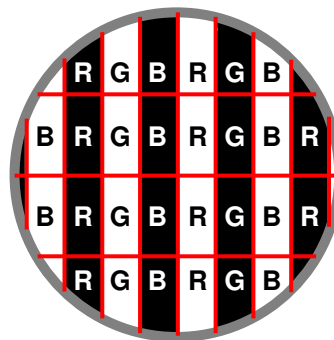

Note (5) The LVDS input characteristics are as follows :

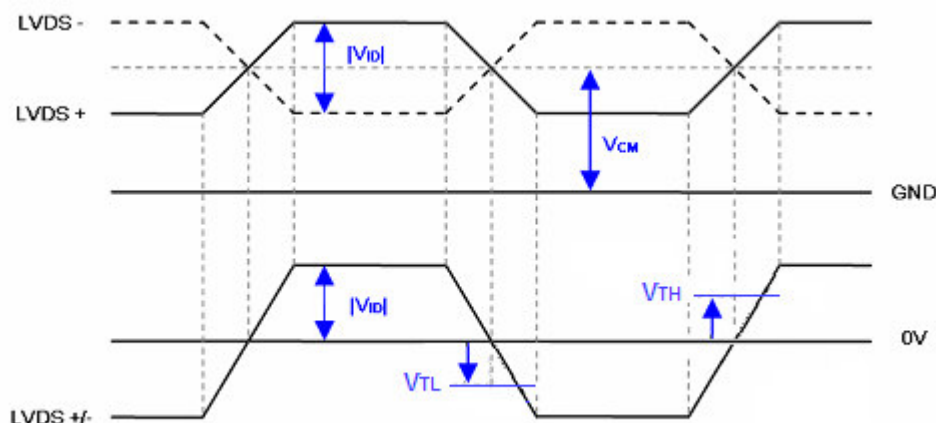

## 3.2 BACKLIGHT CONNECTOR PIN CONFIGURATION

### 3.2.1 LED LIGHT BAR CHARACTERISTICS

( $T_a = 25 \pm 2 \text{ }^\circ\text{C}$ )

Parameter	Symbol	Value			Unit	Note
		Min.	Typ.	Max.		
LED Light Bar Input Voltage Per Input Pin	$V_{PIN}$	--	46.5	51	v	(1), Duty=100%, $I_L = 65\text{mA}$
LED Light Bar Current Per Input Pin	$I_{PIN}$	---	65	69	mA	(1), (2) Duty=100%
Power consumption	$P_{BL}$	---	12.09	13.26	W	(1) Duty=100%, $I_L = 65\text{mA}$
LED Life time	$L_{LED}$	40,000	-	-	Hrs	(3)

Note (1) LED light bar input voltage and current are measured by utilizing a true RMS multimeter as shown below:

Note (2)  $P_{BL}(\text{Typ.}) = I_{PIN}(\text{Typ.}) \times V_{PIN}(\text{Typ.}) \times (4)$ ,  $P_{BL}(\text{Max.}) = I_{PIN}(\text{Typ.}) \times V_{PIN}(\text{Max.}) \times (4)$  input pins, LED light bar circuit is (15)Series, (4)Parallel.

Note (3) The lifetime of LED is defined as the time when LED packages continue to operate under the conditions at  $T_a = 25 \pm 2 \text{ }^\circ\text{C}$  and  $I = (65)\text{mA}$  (per chip) until the brightness becomes  $\leq 50\%$  of its original value.

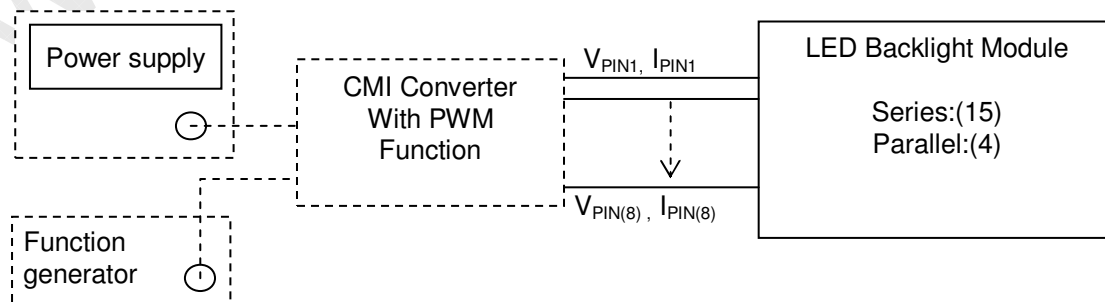

## 3.2.2 LIGHTBAR CONNECTOR PIN ASSIGNMENT

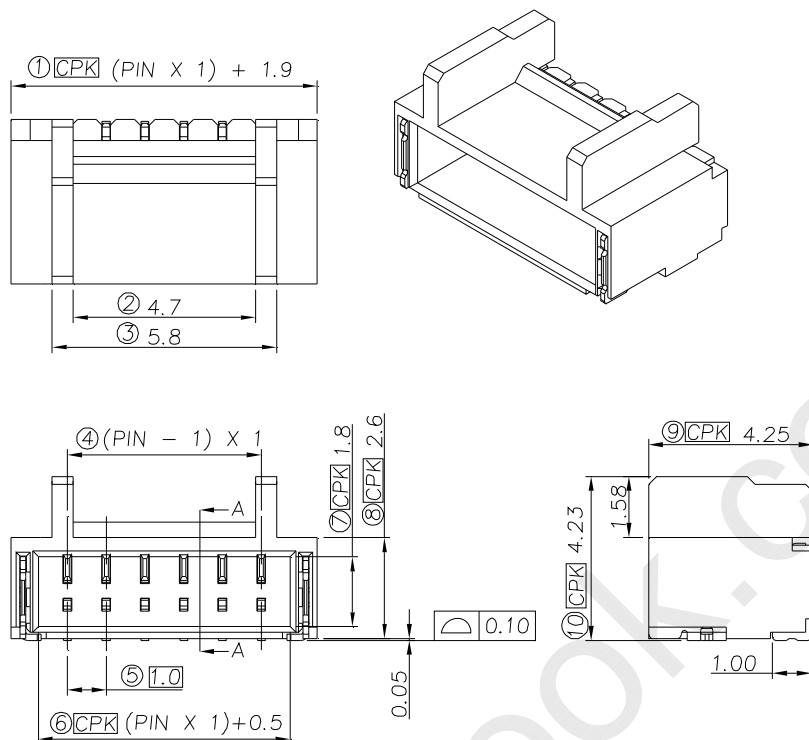

CN1

Pin number	Description
1	Cathode of LED string1
2	Cathode of LED string2
3	VLED
4	VLED
5	Cathode of LED string3
6	Cathode of LED string4

Note(1) Connector: WM13-406-063N(FCN) or equivalent.

Note(2) User's mating connector part No.: IWF13-00106(FCN) or compatible and hook width must be less than 4.5mm.

## 3.3 LVDS INPUT SIGNAL SPECIFICATIONS

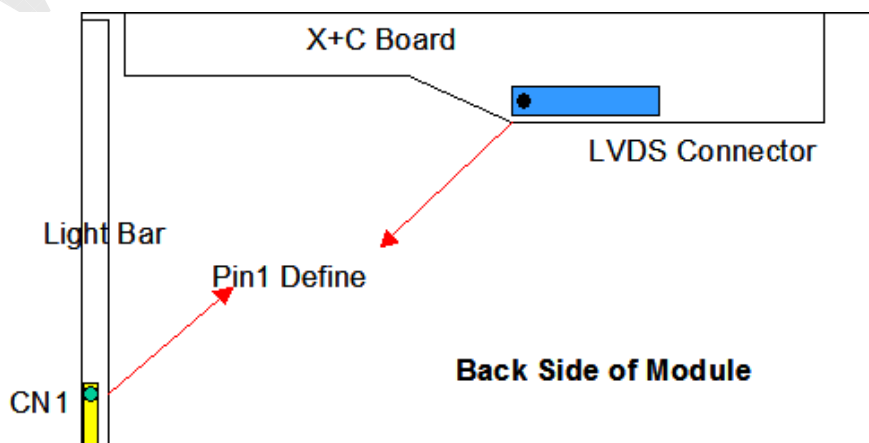

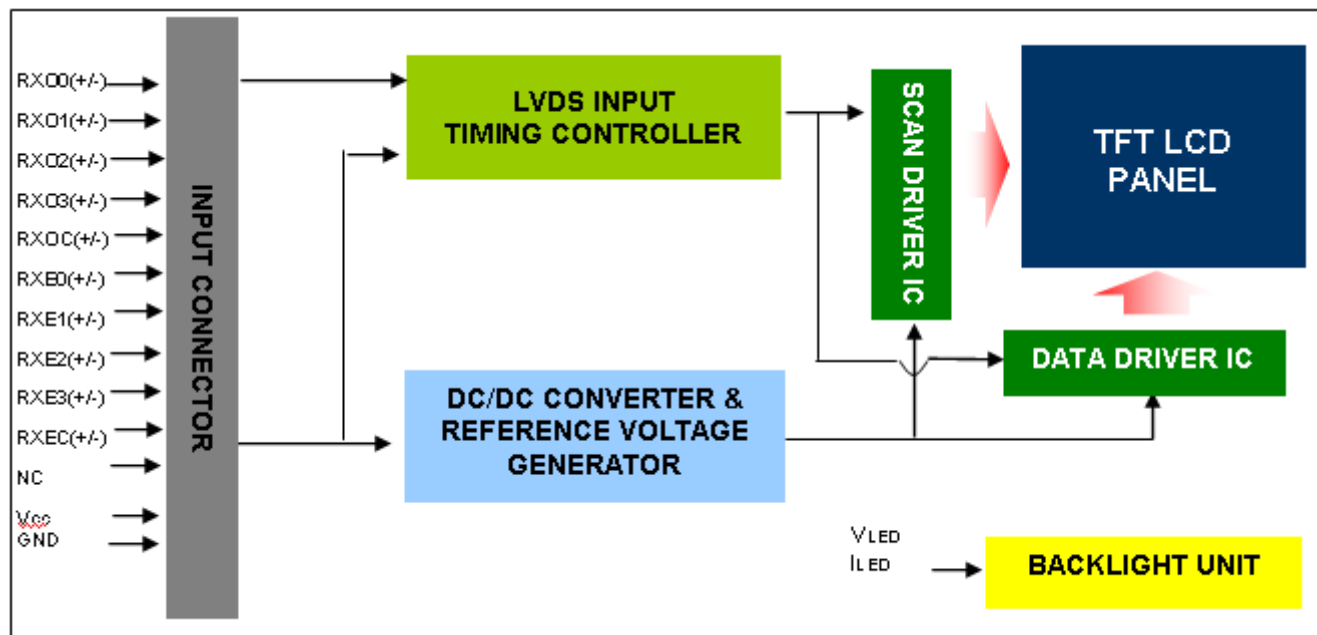
**4. BLOCK DIAGRAM OF INTERFACE**
**4.1 TFT LCD MODULE**

## 5. INPUT TERMINAL PIN ASSIGNMENT

### 5.1 TFT LCD MODULE INPUT

Pin	Name	Description
1	RXO0-	Negative LVDS differential data input. Channel O0 (odd)
2	RXO0+	Positive LVDS differential data input. Channel O0 (odd)
3	RXO1-	Negative LVDS differential data input. Channel O1 (odd)
4	RXO1+	Positive LVDS differential data input. Channel O1 (odd)
5	RXO2-	Negative LVDS differential data input. Channel O2 (odd)
6	RXO2+	Positive LVDS differential data input. Channel O2 (odd)
7	GND	Ground
8	RXOC-	Negative LVDS differential clock input. (odd)
9	RXOC+	Positive LVDS differential clock input. (odd)
10	RXO3-	Negative LVDS differential data input. Channel O3(odd)
11	RXO3+	Positive LVDS differential data input. Channel O3 (odd)
12	RXE0-	Negative LVDS differential data input. Channel E0 (even)
13	RXE0+	Positive LVDS differential data input. Channel E0 (even)
14	GND	Ground
15	RXE1-	Negative LVDS differential data input. Channel E1 (even)
16	RXE1+	Positive LVDS differential data input. Channel E1 (even)
17	GND	Ground
18	RXE2-	Negative LVDS differential data input. Channel E2 (even)
19	RXE2+	Positive LVDS differential data input. Channel E2 (even)
20	RXEC-	Negative LVDS differential clock input. (even)
21	RXEC+	Positive LVDS differential clock input. (even)
22	RXE3-	Negative LVDS differential data input. Channel E3 (even)
23	RXE3+	Positive LVDS differential data input. Channel E3 (even)
24	GND	Ground
25	NC	For LCD internal use only, Do not connect
26	NC	For LCD internal use only, Do not connect
27	NC	For LCD internal use only, Do not connect
28	VCC	+5.0V power supply
29	VCC	+5.0V power supply
30	VCC	+5.0V power supply

Note (1) Connector Part No.: 187098-30091(P-TWO) or equivalent.

Note (2) Mating Wire Cable Connector Part No.: FI-X30H(JAE) or FI-X30HL(JAE)

Note (3) Mating FFC Cable Connector Part No.: 217007-013001 (P-TWO) or JF05X030-1(JAE)

Note (4) The first pixel is odd.

Note (5) Input signal of even and odd clock should be the same timing.

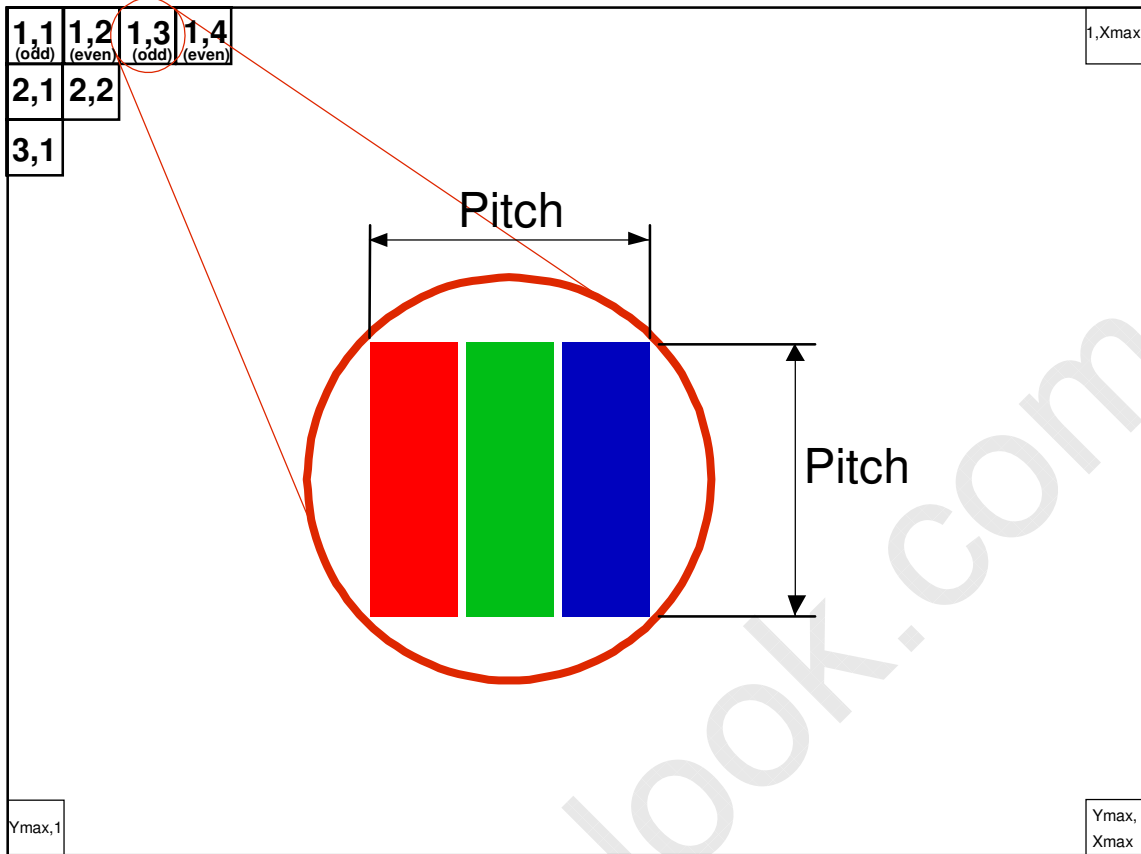

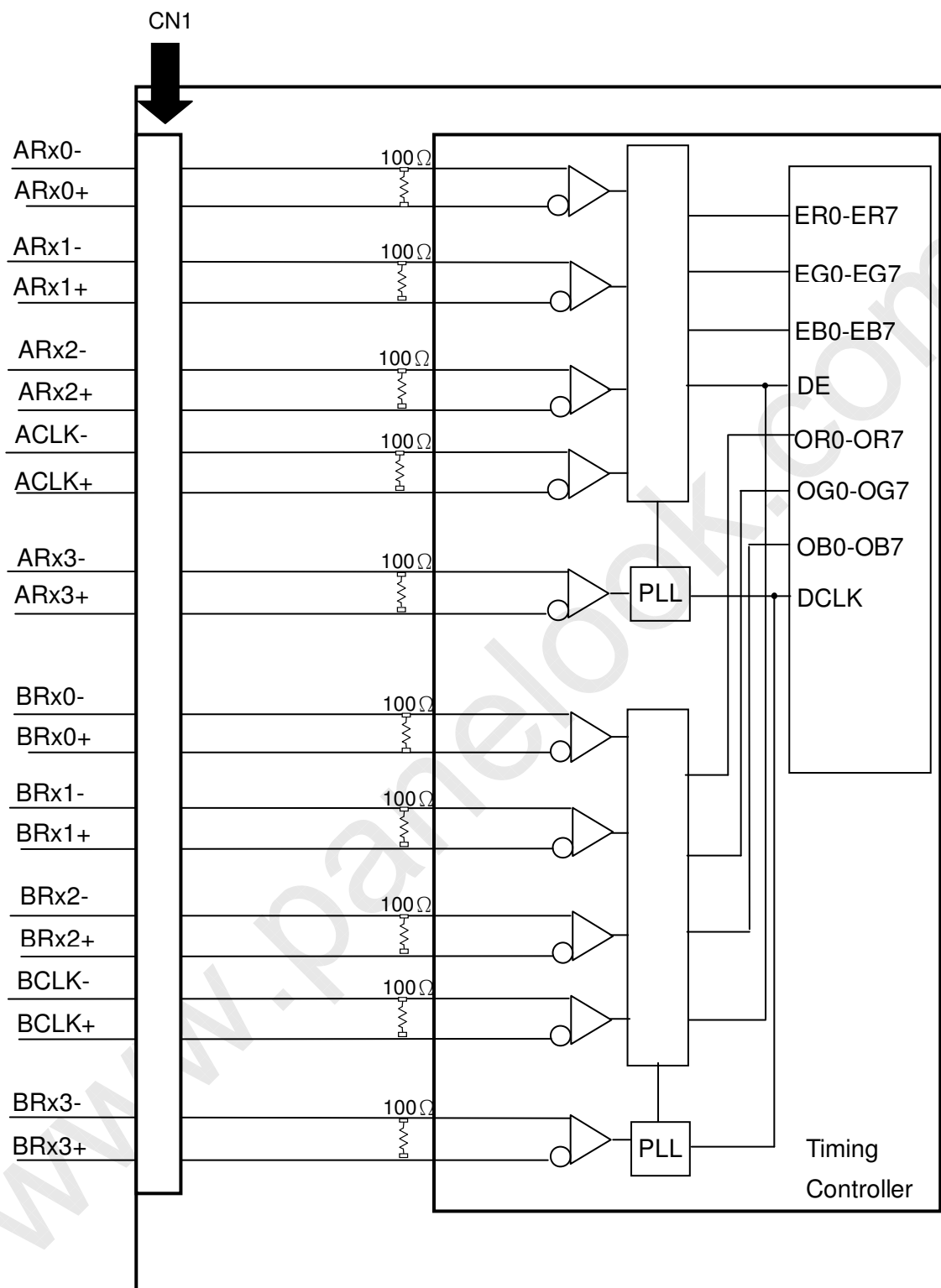
**5.3 BLOCK DIAGRAM OF INTERFACE**



ER0~ER7	Even pixel R data	OR0~OR7	Odd pixel R data
EG0~EG7	Even pixel G data	OG0~OG7	Odd pixel G data
EB0~EB7	Even pixel B data	OB0~OB7	Odd pixel B data
		DE	Data enable signal
		DCLK	Data clock signal

Note (1) The system must have the transmitter to drive the module.

Note (2) LVDS cable impedance shall be 50 ohms per signal line or about 100 ohms per twist-pair line when it is used differentially.

Note (3) Two pixel data send into the module for every clock cycle. The first pixel of the frame is odd pixel and the second pixel is even pixel.

## 5.4 LVDS INTERFACE

VESA Format

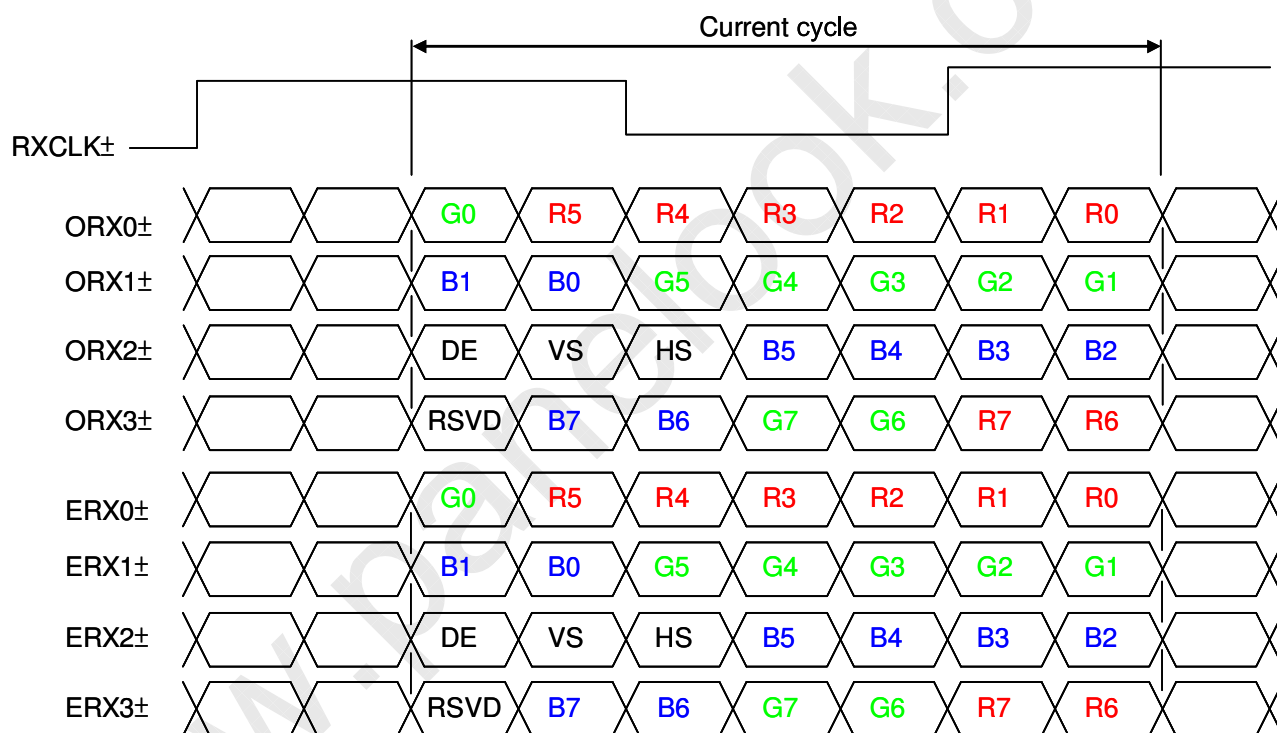

R0~R7: Pixel R Data (7; MSB, 0; LSB)

G0~G7: Pixel G Data (7; MSB, 0; LSB)

B0~B7: Pixel B Data (7; MSB, 0; LSB)

DE : Data enable signal

DCLK : Data clock signal

HS : H-Sync signal

VS : V-Sync signal

Notes (1) RSVD (reserved) pins on the transmitter shall be "H" or "L".

## 5.5 COLOR DATA INPUT ASSIGNMENT

The brightness of each primary color (red, green and blue) is based on the 8-bit gray scale data input for the color. The higher the binary input, the brighter the color. The table below provides the assignment of color versus data input.

Color		Data Signal																							
		Red								Green								Blue							
		R7	R6	R5	R4	R3	R2	R1	R0	G7	G6	G5	G4	G3	G2	G1	G0	B7	B6	B5	B4	B3	B2	B1	B0
Basic Colors	Black	0	0	0	0	0	0	0	0	0	0	0	0	0	0	0	0	0	0	0	0	0	0	0	0
	Red	1	1	1	1	1	1	1	1	0	0	0	0	0	0	0	0	0	0	0	0	0	0	0	0
	Green	0	0	0	0	0	0	0	0	1	1	1	1	1	1	1	1	0	0	0	0	0	0	0	0
	Blue	0	0	0	0	0	0	0	0	0	0	0	0	0	0	0	0	1	1	1	1	1	1	1	1
	Cyan	0	0	0	0	0	0	0	0	1	1	1	1	1	1	1	1	1	1	1	1	1	1	1	1
	Magenta	1	1	1	1	1	1	1	1	0	0	0	0	0	0	0	0	1	1	1	1	1	1	1	1
	Yellow	1	1	1	1	1	1	1	1	1	1	1	1	1	1	1	1	0	0	0	0	0	0	0	0
	White	1	1	1	1	1	1	1	1	1	1	1	1	1	1	1	1	1	1	1	1	1	1	1	1
Gray Scale Of Red	Red(0) / Dark	0	0	0	0	0	0	0	0	0	0	0	0	0	0	0	0	0	0	0	0	0	0	0	0
	Red(1)	0	0	0	0	0	0	1	0	0	0	0	0	0	0	0	0	0	0	0	0	0	0	0	0
	Red(2)	0	0	0	0	0	1	0	0	0	0	0	0	0	0	0	0	0	0	0	0	0	0	0	0
	:	:	:	:	:	:	:	:	:	:	:	:	:	:	:	:	:	:	:	:	:	:	:	:	:
	:	:	:	:	:	:	:	:	:	:	:	:	:	:	:	:	:	:	:	:	:	:	:	:	:
	Red(253)	1	1	1	1	1	1	0	1	0	0	0	0	0	0	0	0	0	0	0	0	0	0	0	0
	Red(254)	1	1	1	1	1	1	1	0	0	0	0	0	0	0	0	0	0	0	0	0	0	0	0	0
	Red(255)	1	1	1	1	1	1	1	1	0	0	0	0	0	0	0	0	0	0	0	0	0	0	0	0
Gray Scale Of Green	Green(0) / Dark	0	0	0	0	0	0	0	0	0	0	0	0	0	0	0	0	0	0	0	0	0	0	0	0
	Green(1)	0	0	0	0	0	0	0	0	0	0	0	0	0	0	1	0	0	0	0	0	0	0	0	0
	Green(2)	0	0	0	0	0	0	0	0	0	0	0	0	0	0	1	0	0	0	0	0	0	0	0	0
	:	:	:	:	:	:	:	:	:	:	:	:	:	:	:	:	:	:	:	:	:	:	:	:	:
	:	:	:	:	:	:	:	:	:	:	:	:	:	:	:	:	:	:	:	:	:	:	:	:	:
	Green(253)	0	0	0	0	0	0	0	1	1	1	1	1	1	1	0	1	0	0	0	0	0	0	0	0
	Green(254)	0	0	0	0	0	0	0	1	1	1	1	1	1	1	1	0	0	0	0	0	0	0	0	0
	Green(255)	0	0	0	0	0	0	0	1	1	1	1	1	1	1	1	1	0	0	0	0	0	0	0	0
Gray Scale Of Blue	Blue(0) / Dark	0	0	0	0	0	0	0	0	0	0	0	0	0	0	0	0	0	0	0	0	0	0	0	0
	Blue(1)	0	0	0	0	0	0	0	0	0	0	0	0	0	0	0	0	0	0	0	0	0	0	0	1
	Blue(2)	0	0	0	0	0	0	0	0	0	0	0	0	0	0	0	0	0	0	0	0	0	0	1	0
	:	:	:	:	:	:	:	:	:	:	:	:	:	:	:	:	:	:	:	:	:	:	:	:	:
	:	:	:	:	:	:	:	:	:	:	:	:	:	:	:	:	:	:	:	:	:	:	:	:	:
	Blue(253)	0	0	0	0	0	0	0	0	0	0	0	0	0	0	0	0	1	1	1	1	1	1	0	1
	Blue(254)	0	0	0	0	0	0	0	0	0	0	0	0	0	0	0	0	1	1	1	1	1	1	1	0
	Blue(255)	0	0	0	0	0	0	0	0	0	0	0	0	0	0	0	0	1	1	1	1	1	1	1	1

Note (1) 0: Low Level Voltage, 1: High Level Voltage

**6. INTERFACE TIMING**
**6.1 INPUT SIGNAL TIMING SPECIFICATIONS**

The input signal timing specifications are shown as the following table and timing diagram. ( $T_a = 25 \pm 2 \text{ }^\circ\text{C}$ )

Signal	Item	Symbol	Min.	Typ.	Max.	Unit	Note
LVDS Receiver Clock	Frequency	$F_{\text{clkin}}$ ( $=1/T_C$ )	58.54	74.25	98	MHz	
	Period	$T_C$	—	13.47	—	ns	
	Input cycle to Cycle jitter	$T_{\text{rcl}}$	$-0.02 \cdot T_C$	—	$0.02 \cdot T_C$	ps	(2)
	Spread spectrum modulation range	$F_{\text{clkin\_mod}}$	$0.97 \cdot F_{\text{clkin}}$	—	$1.03 \cdot F_{\text{clkin}}$	MHz	(3)
	Spread spectrum modulation frequency	$F_{\text{SSM}}$			200	KHz	
LVDS Receiver Data	Setup Time	$T_{\text{lvsu}}$	600	—	—	ps	
	Hold Time	$T_{\text{lvhd}}$	600	—	—	ps	
Vertical Active Display Term	Frame Rate	$F_r$	50	60	75	Hz	
	Total	$T_v$	1115	1125	1135	Th	$T_v = T_{\text{vd}} + T_{\text{vb}}$
	Display	$T_{\text{vd}}$	1080	1080	1080	Th	
	Blank	$T_{\text{vb}}$	35	45	55	Th	
Horizontal Active Display Term	Total	$T_h$	1050	1100	1150	$T_c$	$T_h = T_{\text{hd}} + T_{\text{hb}}$
	Display	$T_{\text{hd}}$	960	960	960	$T_c$	
	Blank	$T_{\text{hb}}$	90	140	190	$T_c$	

Note: Because this module is operated by DE only mode, Hsync and Vsync input signals are ignored.

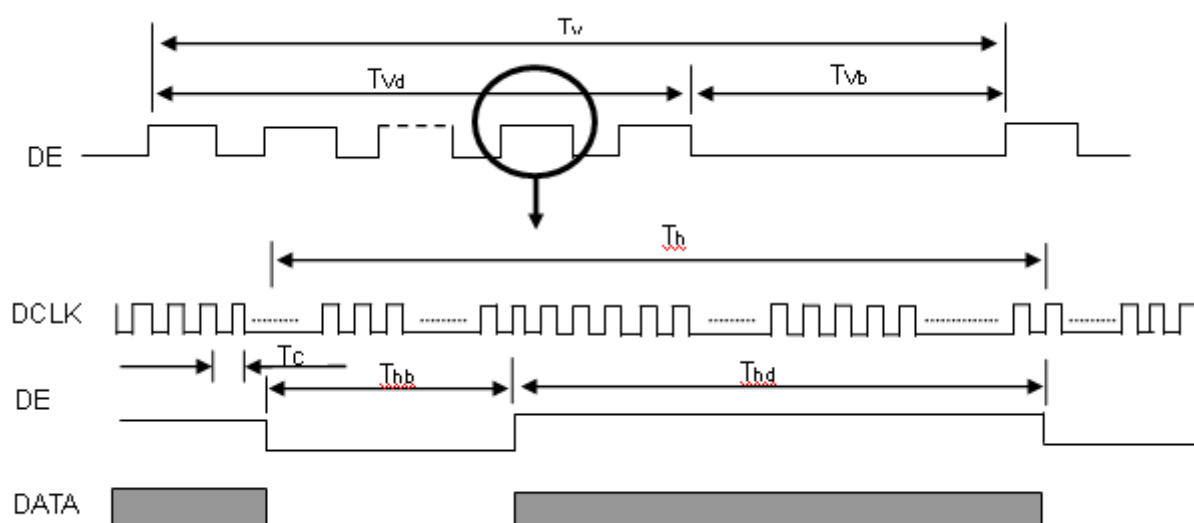
**INPUT SIGNAL TIMING DIAGRAM**

Note (1) Please make sure the range of frame rate has follow the below equation :

$$Fr(\max) \geq F_{clkin} / T_v \times T_h \geq Fr(\min)$$

Note (2) The input clock cycle-to-cycle jitter is defined as below figures.  $Tr_{cl} = |T_1 - T_2|$

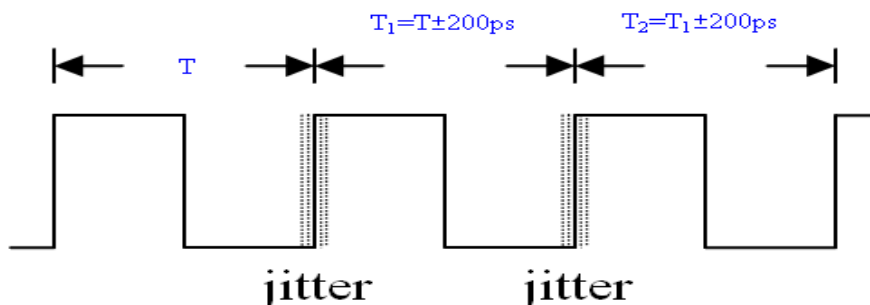

Note (3) The SSCG (Spread spectrum clock generator) is defined as below figures.

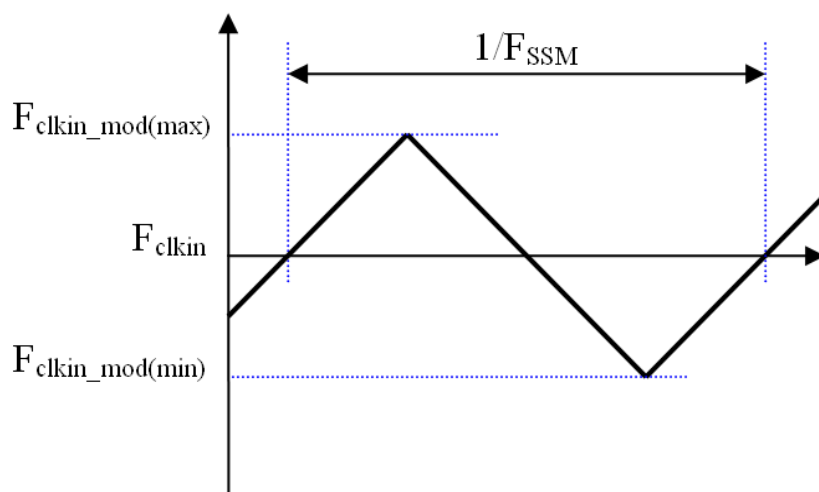

## 6.2 POWER ON/OFF SEQUENCE

( $T_a = 25 \pm 2 \text{ }^\circ\text{C}$ )

To prevent a latch-up or DC operation of LCD module, the power on/off sequence should be as the diagram below.

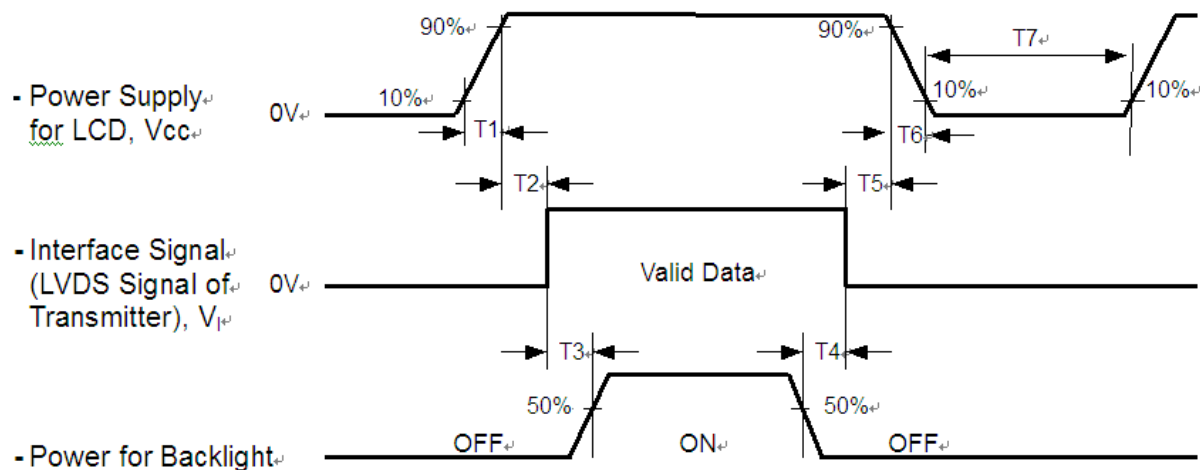

Timing Specifications:

Parameters	Values			Units
	Min	Typ.	Max	
T1	0.5	--	10	ms
T2	0	--	50	ms
T3	450	--	--	ms
T4	90	--	--	ms
T5	0	--	50	ms
T6	0.5	--	100	ms
T7	500	--	--	ms

Note (1) The supply voltage of the external system for the module input should be the same as the definition of Vcc.

Note (2) When the backlight turns on before the LCD operation of the LCD turns off, the display may momentarily become abnormal screen.

Note (3) In case of VCC = off level, please keep the level of input signals on the low or keep a high impedance.

Note (4) T7 should be measured after the module has been fully discharged between power off and on period.

Note (5) Interface signal shall not be kept at high impedance when the power is on.

Note (6) CMI won't take any responsibility for the products which are damaged by the customers not following the Power Sequence.

Note (7) There might be slight electronic noise when LCD is turned off (even backlight unit is also off). To avoid this symptom, we suggest "Vcc falling timing" to follow "T6 spec".

## 7. OPTICAL CHARACTERISTICS

### 7.1 TEST CONDITIONS

Item	Symbol	Value	Unit
Ambient Temperature	Ta	25±2	oC
Ambient Humidity	Ha	50±10	%RH
Supply Voltage	VCC	5	V
Input Signal	According to typical value in "3. ELECTRICAL CHARACTERISTICS"		
LED Light Bar Input Current Per Input Pin	I <sub>PIN</sub>	65± 1.95	mA <sub>DC</sub>
PWM Duty Ratio	D	100	%
LED Light Bar Test Converter	CMI 35-D065452		

The LCD module should be stabilized at given temperature for 1 hour to avoid abrupt temperature change during measuring. In order to stabilize the luminance, the measurement should be executed after lighting backlight for 1 hour in a windless room.

## 7.2 OPTICAL SPECIFICATIONS

The relative measurement methods of optical characteristics are shown in 7.2. The following items should be measured under the test conditions described in 7.1 and stable environment shown in 7.1.

Item		Symbol	Condition	Min.	Typ.	Max.	Unit	Note		
Contrast Ratio		CR	$\theta_x=0^\circ, \theta_y=0^\circ$ Viewing angle at normal direction	700	1000	-	-	Note (2)		
Response Time		$T_R$		-	1.5	2.5	ms	Note (3)		
		$T_F$		-	3.5	5.5				
Center Luminance of White		LC		200	250	-	cd/m <sup>2</sup>	Note (5)		
White Variation		$\delta W$		70	-	-	%	Note (7)		
Cross Talk		CT		-	-	-	%	Note (6)		
Color Chromaticity	Red	Rx		Typ. -0.03	0.632	Typ. +0.03	-	-	(1)(4)	
		Ry								0.337
	Green	Gx								0.302
		Gy								0.622
	Blue	Bx	0.154							
		By	0.052							
	White	Wx	0.285							
		Wy	0.293							
Color Gamut		C.G	-	72	-	%	NTSC			
Viewing Angle	Horizontal	$\theta_{x+} + \theta_{x-}$	CR $\geq$ 10 USB2000	150	170	-	Deg.	(1)(4)		
	Vertical	$\theta_{y++} + \theta_{y-}$		140	160	-				
	Horizontal	$\theta_{x+} + \theta_{x-}$	CR $\geq$ 5 USB2000	160	178	-				
	Vertical	$\theta_{y++} + \theta_{y-}$		150	170	-				

Note (1) Definition of Viewing Angle ( $\theta_x, \theta_y$ ) :

Viewing angles are measured by Autronic Conoscope Cono-80

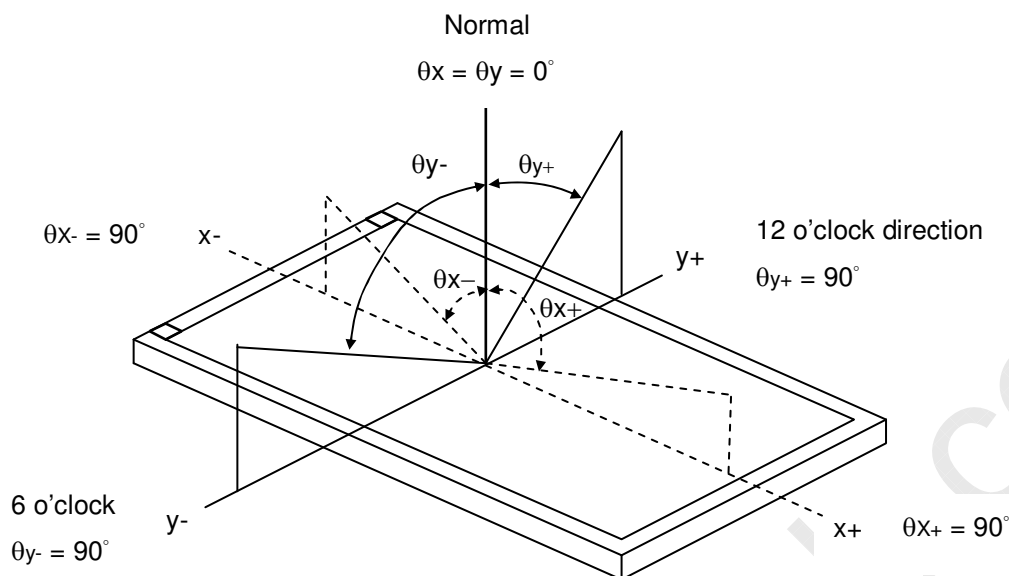

Note (2) Definition of Contrast Ratio (CR) :

The contrast ratio can be calculated by the following expression.

$$\text{Contrast Ratio (CR)} = \frac{\text{Surface Luminance with all white pixels}}{\text{Surface Luminance with all black pixels}}$$

CR = CR (5), where CR (X) is corresponding to the Contrast Ratio of the point X at the figure in Note(7).

Note (3) Definition of Response Time ( $T_R, T_F$ ):

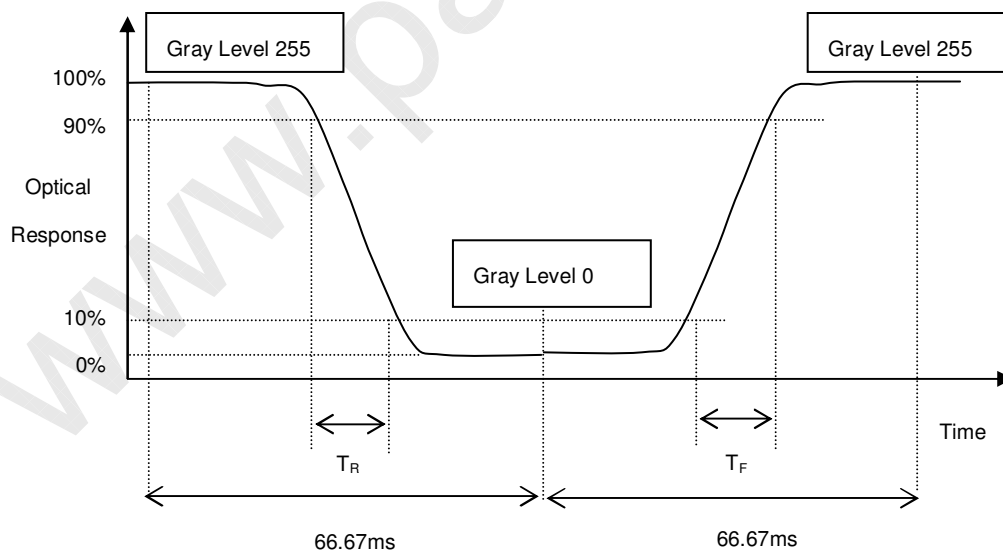



## Note (4) Measurement Setup:

The LCD module should be stabilized at given temperature for 1 hour to avoid abrupt temperature change during measuring. In order to stabilize the luminance, the measurement should be executed after lighting backlight for 1 hour in a windless room.

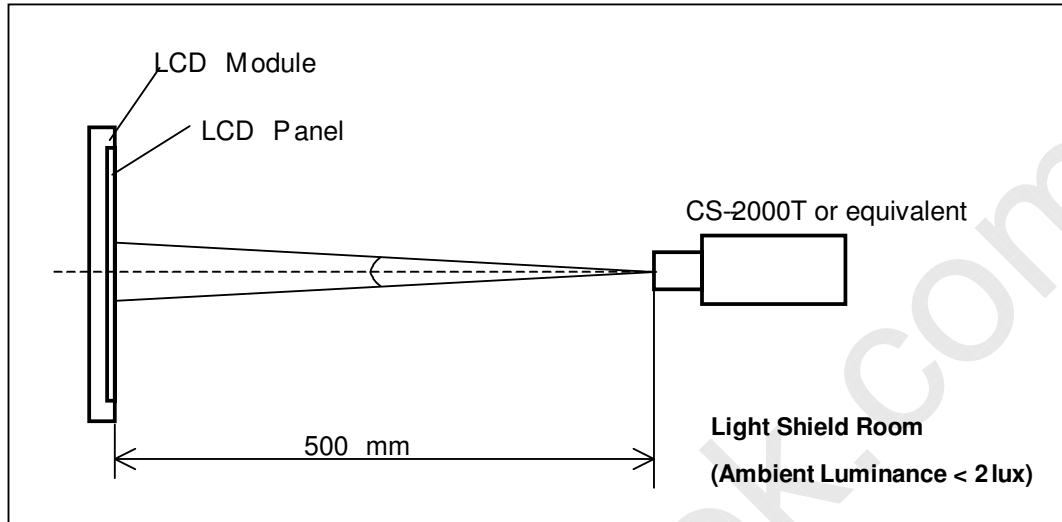

## Note (5) Definition of Luminance of White ( $L_C$ , $L_{AVE}$ ):

Measure the luminance of gray level 255 at center point and 5 points

$L_C = L(5)$ , where  $L(X)$  is corresponding to the luminance of the point X at the figure in Note (7).

## Note (6) Definition of Cross Talk (CT):

$$CT = |Y_B - Y_A| / Y_A \times 100 (\%)$$

Where:

$Y_A$  = Luminance of measured location without gray level 0 pattern (cd/m<sup>2</sup>)

$Y_B$  = Luminance of measured location with gray level 0 pattern (cd/m<sup>2</sup>)

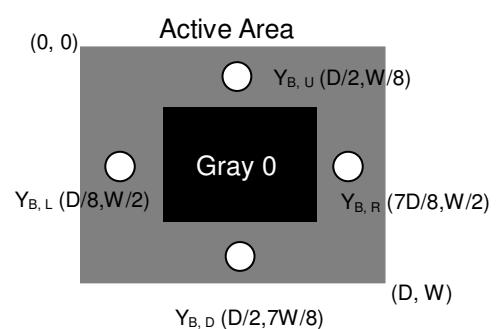
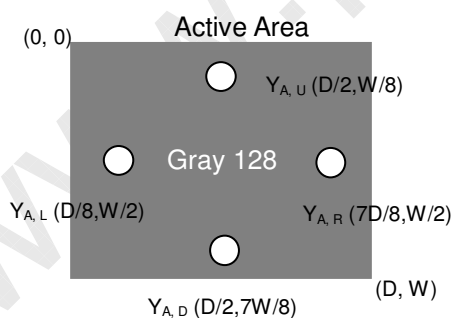

Note (7) Definition of White Variation ( $\delta W$ ):

Measure the luminance of gray level 255 at 9 points

$$\delta W = \text{Minimum [L (1) ~ L (9)]} / \text{Maximum [L (1) ~ L (9)]}$$

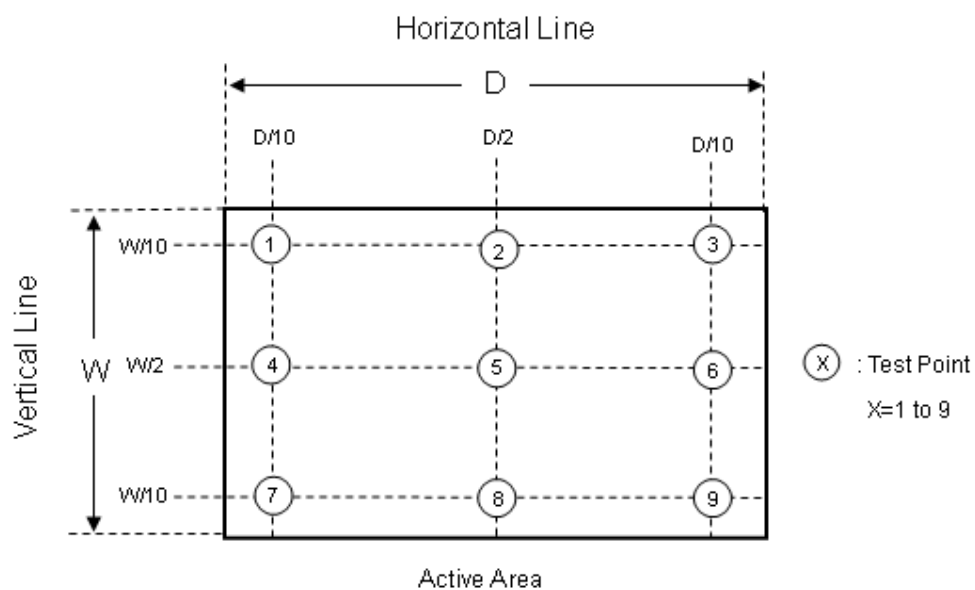

## 8. PRECAUTIONS

### 8.1 ASSEMBLY AND HANDLING PRECAUTIONS

- [ 1 ] Do not apply rough force such as bending or twisting to the module during assembly.
- [ 2 ] It is recommended to assemble or to install a module into the user's system in clean working areas. The dust and oil may cause electrical short or worsen the polarizer.
- [ 3 ] Do not apply pressure or impulse to the module to prevent the damage of LCD panel and Backlight.
- [ 4 ] Always follow the correct power-on sequence when the LCD module is turned on. This can prevent the damage and latch-up of the CMIS LSI chips.
- [ 5 ] Bezel of Set can not press or touch the panel surface. It will make light leakage or scrape.
- [ 6 ] Do not plug in or pull out the I/F connector while the module is in operation.
- [ 7 ] Do not disassemble the module.
- [ 8 ] Use a soft dry cloth without chemicals for cleaning, because the surface of polarizer is very soft and easily scratched.
- [ 9 ] Moisture can easily penetrate into LCD module and may cause the damage during operation.
- [ 10 ] When storing modules as spares for a long time, the following precaution is necessary.
  - [ 10.1 ] Do not leave the module in high temperature, and high humidity for a long time. It is highly recommended to store the module with temperature from 0 to 35°C at normal humidity without condensation.
  - [ 10.2 ] The module shall be stored in dark place. Do not store the TFT-LCD module in direct sunlight or fluorescent light.

### 8.2 SAFETY PRECAUTIONS

- [ 1 ] If the liquid crystal material leaks from the panel, it should be kept away from the eyes or mouth. In case of contact with hands, skin or clothes, it has to be washed away thoroughly with soap.
- [ 2 ] After the module's end of life, it is not harmful in case of normal operation and storage.

### 8.3 SAFETY REVIEW

#### 8.3.1 SAFETY STANDARDS

The LCD module should be certified with safety regulations as follows:

Requirement	Standard	Remark
UL	UL60950-1:2006 or Ed.2:2007	
	UL60065 Ed.7:2007	
cUL/CSA	CAN/CSA C22.2 No.60950-1-03 or 60950-1-07	
	CAN/CSA C22.2 No.60065-03:2006 + A1:2006	
CB	IEC60950-1:2005 / EN60950-1:2006+ A11:2009	
	IEC60065:2001+ A1:2005 / EN60065:2002 + A1:2006 + A11:2008	

9. DEFINITION OF LABELS

9.1 CMI MODULE LABEL

The barcode nameplate is pasted on each module as illustration, and its definitions are as following explanation.

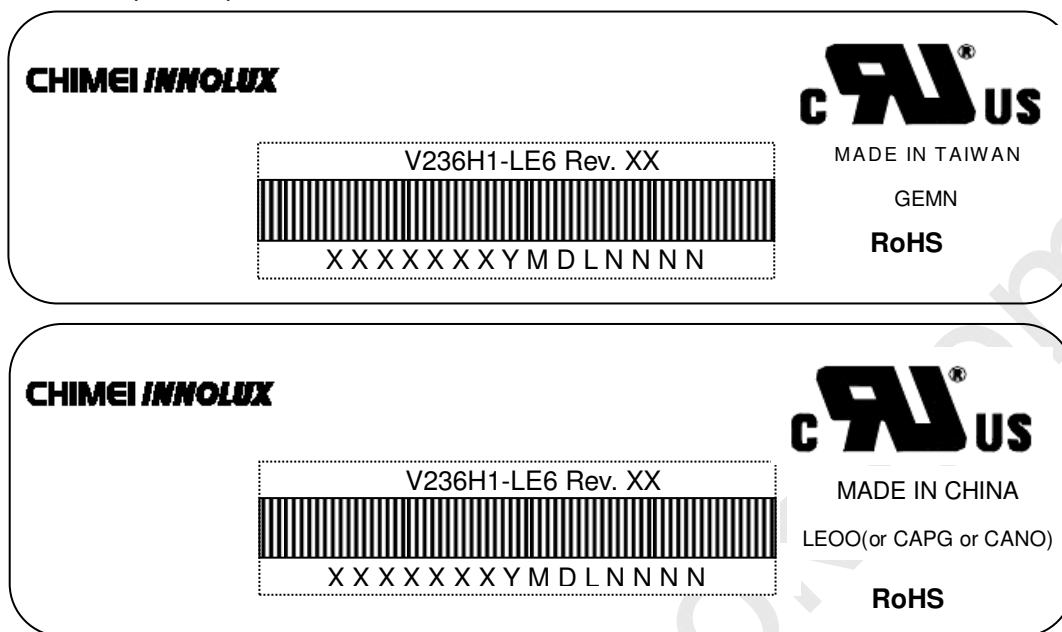

Model Name: V236H1 –LE6

Revision: Rev. XX, for example: A0, A1... B1, B2... or C1, C2...etc.

Serial ID: X X X X X X Y M D L N N N N

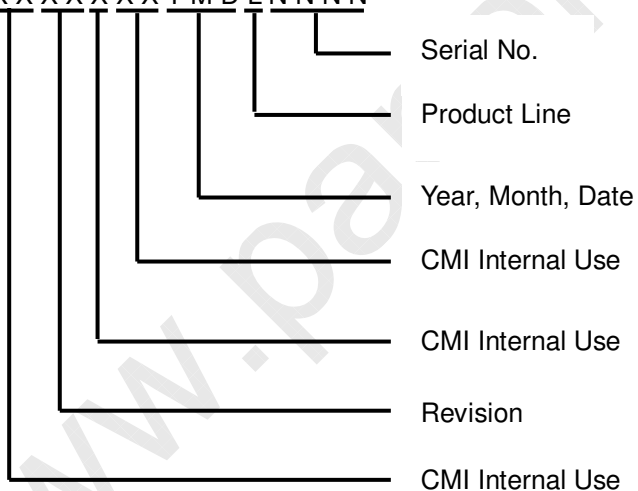

Serial ID includes the information as below:

Manufactured Date:

Year : 2001=1, 2002=2, 2003=3, 2004=4...2010=0, 2011=1, 2012=2...

Month: 1~9, A~C, for Jan. ~ Dec.

Day: 1~9, A~Y, for 1st to 31st, exclude I ,O, and U.

Revision Code : Cover all the change

Serial No. : Manufacturing sequence of product

Product Line : 1 → Line1, 2 → Line 2, ...etc.

## 10. PACKAGING

### 10.1 PACKING SPECIFICATIONS

- (1) 11 LCD modules / 1 Box
- (2) Box dimensions: 620(L) X 348(W) X 430(H) mm
- (3) Weight: approximately: 30.1kg (11 modules per box)

### 10.2 PACKAGING METHOD

- (1) Carton Packing should have no failure in the following reliability test items.

Test Item	Test Conditions	Note
Vibration	ISTA STANDARD Random, Frequency Range: 1 – 200 Hz Top & Bottom: 30 minutes (+Z), 10 min (-Z), Right & Left: 10 minutes (X) Back & Forth 10 minutes (Y)	Non Operation
Dropping Test	1 Corner, 3 Edge, 6 Face, 31cm	Non Operation

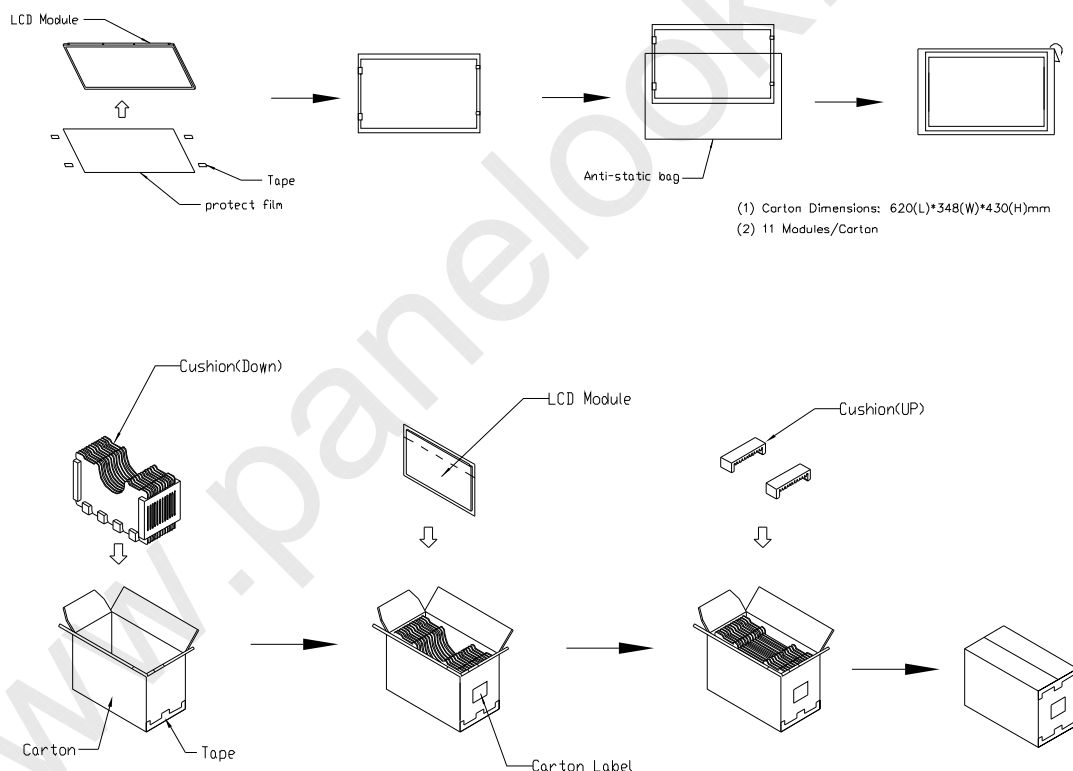
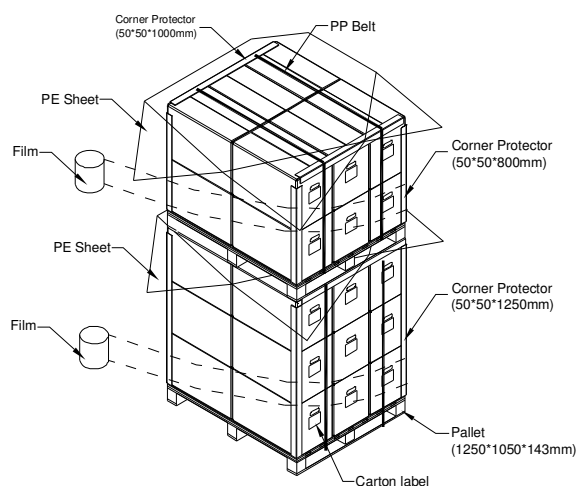

Figure 10-1 packing method

For ocean shipping

Sea / Land Transportation (40ft HQ Container)



Sea / Land Transportation (40ft/20ft Container)

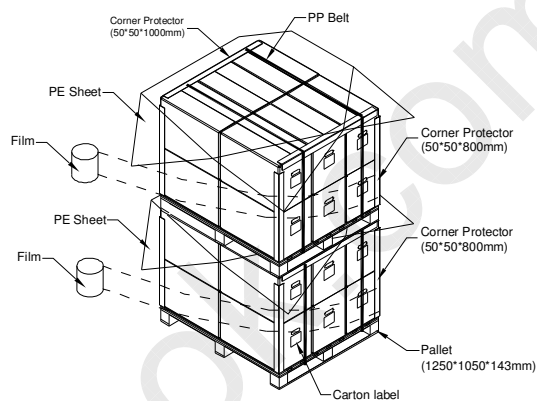

For air transport

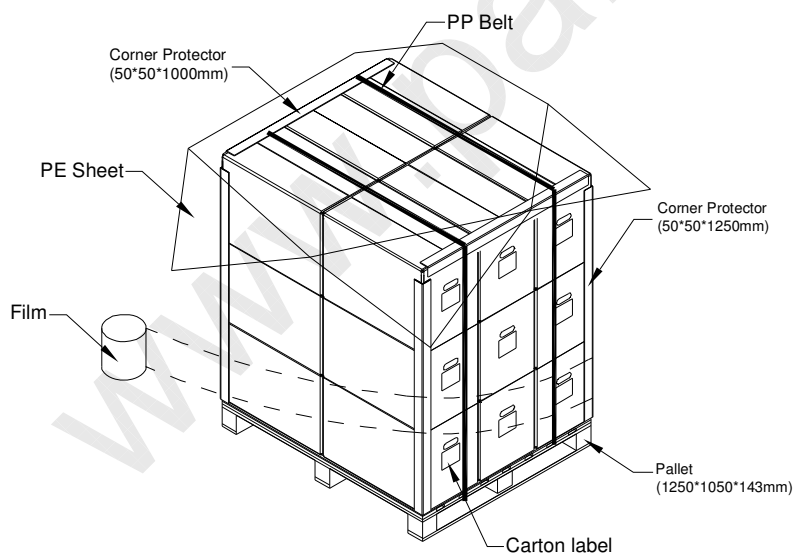
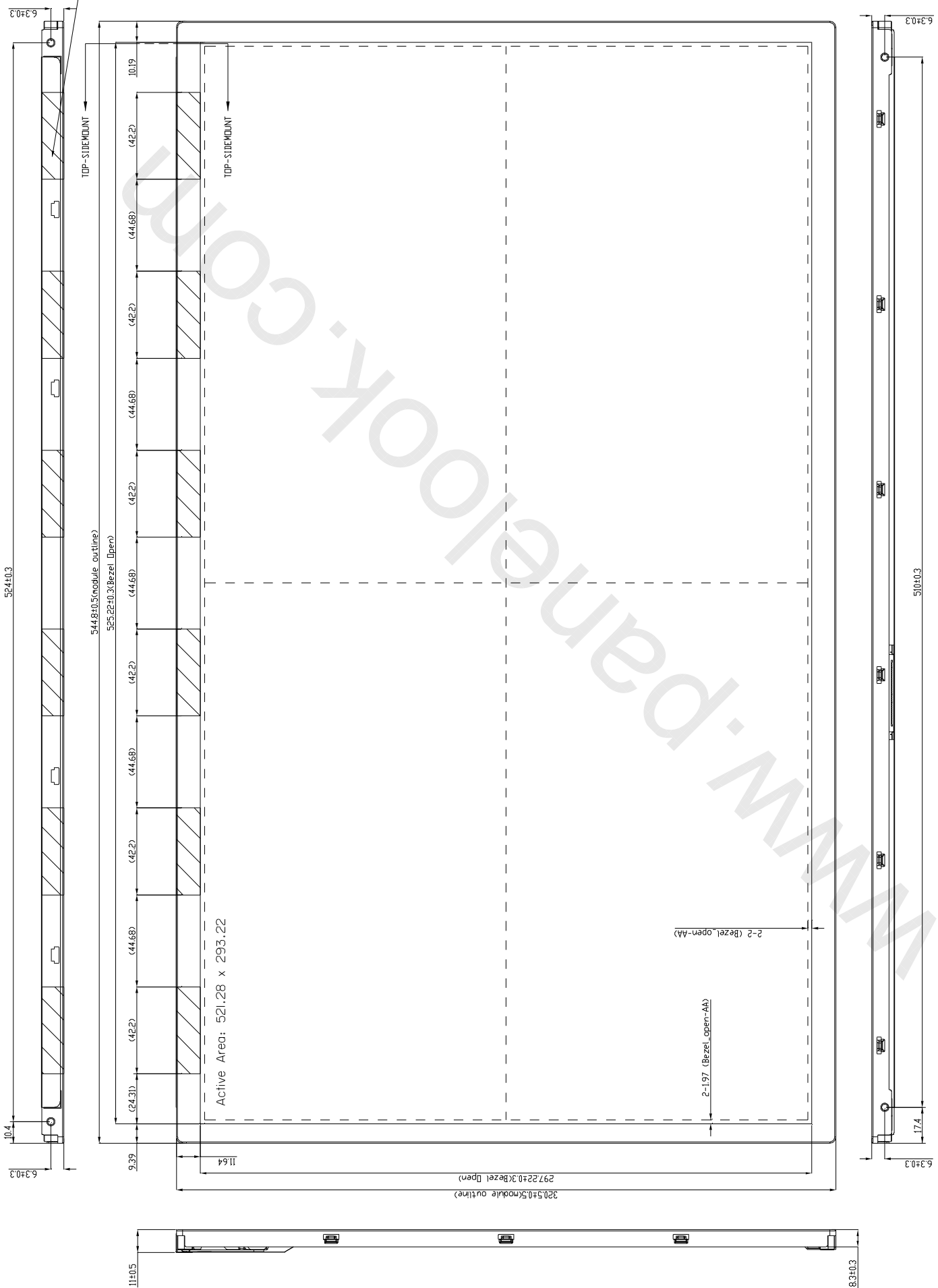

Figure 10-2 packing method

REV	DESCRIPTION	DATE



DATA CDF Position(X6),  
DON'T TOUCH!!  
(SI mechanical structure should  
not touch the positions of Data  
CDF Position)

ACTIVE AREA

- NOTE:
1. THE DIMENSION EXCLUDES DEFORMATION
  2. TOLERANCE WITHOUT NOTICED TO BE  $\pm 0.5\text{MM}$
  3. TORQUE OF M3 USER HOLE SHOULD BE WITHIN 5 kgf-cm

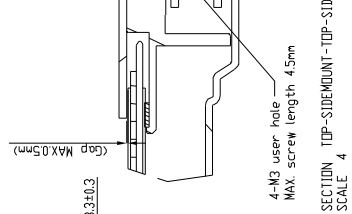

4-M3 user hole  
MAX. screw length 4.5mm  
SECTION TOP-SIDE MOUNT-TOP-SIDE MOUNT  
SCALE 4

