

- Tentative Specification
- Preliminary Specification
- Approval Specification

MODEL NO.: V236H3
SUFFIX: LS1

Customer:	
APPROVED BY	SIGNATURE
Name / Title _____	_____
Note	
<hr/> Please return 1 copy for your confirmation with your signature and comments.	

Approved By	Checked By	Prepared By
Chao-Chun Chung	Roger Huang	CS Tsai

CONTENTS

1. GENERAL DESCRIPTION	5
1.1 OVERVIEW	5
1.2 FEATURES	5
1.3 APPLICATION	5
1.4 GENERAL SPECIFICATIONS	5
1.5 MECHANICAL SPECIFICATIONS	6
2. ABSOLUTE MAXIMUM RATINGS	7
2.1 ABSOLUTE RATINGS OF ENVIRONMENT	7
2.2 PACKAGE STORAGE	8
2.3 ELECTRICAL ABSOLUTE RATINGS	8
2.3.1 TFT LCD MODULE	8
3. ELECTRICAL CHARACTERISTICS	9
3.1 TFT LCD MODULE	9
3.2 BACKLIGHT CONNECTOR PIN CONFIGURATION	12
3.2.1 LED LIGHT BAR CHARACTERISTICS	12
3.2.2 LIGHTBAR CONNECTOR PIN ASSIGNMENT	13
3.3 LVDS INPUT SIGNAL SPECIFICATIONS	14
3.3.1 LVDS DATA MAPPING TABLE	14
4. BLOCK DIAGRAM OF INTERFACE	15
4.1 TFT LCD MODULE	15
5. INPUT TERMINAL PIN ASSIGNMENT	16
5.1 TFT LCD MODULE INPUT	16
5.2 BLOCK DIAGRAM OF INTERFACE	22
5.3 LVDS INTERFACE	24
5.4 COLOR DATA INPUT ASSIGNMENT	25
6. INTERFACE TIMING	27
6.1 INPUT SIGNAL TIMING SPECIFICATIONS	27
6.1.1 TIMING SPEC FOR FRAME RATE ($F_{r5} = 100\text{Hz}$)	27
6.1.2 TIMING SPEC FOR FRAME RATE ($F_{r6} = 120\text{Hz}$)	27
6.2 POWER ON/OFF SEQUENCE	31
6.2.1 POWER ON/OFF SEQUENCE ($T_a = 25 \pm 2 \text{ }^\circ\text{C}$)	31
6.2.2 2D to 3D SIGNAL SEQUENCE WITHOUT VCC TURN OFF AND TURN ON	32

7. OPTICAL CHARACTERISTICS.....	33
7.1 TEST CONDITIONS.....	33
7.2 OPTICAL SPECIFICATIONS	34
8. PRECAUTIONS.....	39
8.1 ASSEMBLY AND HANDLING PRECAUTIONS	39
8.2 SAFETY PRECAUTIONS	39
9. DEFINITION OF LABELS.....	40
9.1 CMI MODULE LABEL	40
10. PACKAGING.....	41
10.1 PACKAGING SPECIFICATIONS	41
10.2 PACKAGING METHOD.....	41
11. MECHANICAL CHARACTERISTIC.....	42

REVISION HISTORY

Version	Date	Page(New)	Section	Description
Ver. 0.0	Sep. 24,2010	All	All	The tentative specification was first issued.
Ver.0.1	Oct. 08,2010	5	1.1	Interface is described with "4ch-LVDS"
		5	1.4	Power consumption is modified
		9	3.1	Power consumption and power supply current is modified
		14	4.1	CNF1 and CN6 are modified
		18	5.1	CN6 pin 5, 6 are modified
		25	6.1	3D Mode timing is changed
Ver.1.0	Oct. 13, 2010	All	All	The preliminary specification was first issued
		6	1.5	Update weight
		12	3.2.1	Add 3D converter design reference
		18	5.1	Note (2)~(8) are modified
		26, 27	6.1	Note (7) is added
Ver.2.0	Nov. 11, 2010	All	All	100Hz timing is added
		All	All	The Approval specification was first issued
Ver.2.1	Nov. 25, 2010	5	1.4	Power consumption is modified
		9	3.1	Power consumption and Power supply current are modified
		15	4.1	Delete Pin "LD_EN"
		16, 19	5.1	CNF1 pin 6 and CN6 pin 5 , description is modified
		32	6.2.2	New added
		33	7.1	New added figure
		34	7.2	3D luminance and 3D cross talk are added for reference
		35~38	7.2	Note() are modified and added

1. GENERAL DESCRIPTION

1.1 OVERVIEW

V236H3-LS1 is a 23.6" TFT Liquid Crystal Display module with WLED Backlight unit and 4ch-LVDS interface. This module supports 1920 x 1080 Full HDTV format and can display up to 16.7M colors (6 bit +FRC). The converter module for Backlight unit is not built in.

1.2 FEATURES

- Extra-wide viewing angle.
- High contrast ratio.
- Fast response time.
- High color saturation.
- Full HD (1920 x 1080 pixels) resolution.
- DE (Data Enable) only mode.
- LVDS (Low Voltage Differential Signaling) interface.
- RoHS compliance.
- support 120Hz frame rate

1.3 APPLICATION

- Standard Living Room TVs
- MFM Application
- 3D Application

1.4 GENERAL SPECIFICATIONS

Item	Specification	Unit	Note
Active Area	521.28(H) x 293.22(V) (23.547" diagonal)	mm	(1)
Bezel Opening Area	525.22 (H) x 297.22 (V)	mm	
Driver Element	a-si TFT active matrix	-	-
Pixel Number	1920 x R.G.B. x 1080	pixel	-
Pixel Pitch(Sub Pixel)	0.0905(H) x 0.2715(V)	mm	-
Pixel Arrangement	RGB vertical stripe	-	-
Power consumption	21.63W (LVDS input Power 7.8 W + LED Backlight Power 13.83 W)	Watt	(2)
Display Colors	16.7M	color	-
Display Operation Mode	Transmissive mode / Normally white	-	-
Surface Treatment	Anti-Glare coating (Haze 25%)	-	(3)

Note (1) Please refer to the attached drawings in chapter 9 for more information about the front and back outlines.

Note (2) Please refer sec 3.1 and 3.2 for more information of Power consumption

Note (3) The spec. of the surface treatment is temporarily for this phase. CMI reserves the rights to change this feature.

1.5 MECHANICAL SPECIFICATIONS

Item		Min.	Typ.	Max.	Unit	Note
Module Size	Horizontal (H)	544.3	544.8	545.3	mm	(1)
	Vertical (V)	320.0	320.5	321.0	mm	(1)
	Depth (D)	14.1	14.6	15.1	mm	(1)
Weight		-	2550	2650	g	-

Note (1) Please refer to the attached drawings for more information of front and back outline dimensions.

2. ABSOLUTE MAXIMUM RATINGS

2.1 ABSOLUTE RATINGS OF ENVIRONMENT

Item	Symbol	Value		Unit	Note
		Min.	Max.		
Storage Temperature	TST	-20	+60	°C	(1)
Operating Ambient Temperature	TOP	0	50	°C	(1), (2)
Shock (Non-Operating)	SNOP	-	50	G	(3), (5)
Vibration (Non-Operating)	VNOP	-	1.0	G	(4), (5)

Note (1) Temperature and relative humidity range is shown in the figure below.

- (a) 90 %RH Max. ($T_a \leq 40$ °C).
- (b) Wet-bulb temperature should be 39 °C Max. ($T_a > 40$ °C).
- (c) No condensation.

Note (2) The maximum operating temperature is based on the test condition that the surface temperature of display area is less than or equal to 65 °C with LCD module alone in a temperature controlled chamber. Thermal management should be considered in final product design to prevent the surface temperature of display area from being over 65 °C. The range of operating temperature may degrade in case of improper thermal management in final product design.

Note (3) 11 ms, half sine wave, 1 time for $\pm X$, $\pm Y$, $\pm Z$.

Note (4) 10 ~ 300 Hz, 10 min, 1 time each X, Y, Z.

Note (5) At testing Vibration and Shock, the fixture in holding the module has to be hard and rigid enough so that the module would not be twisted or bent by the fixture.

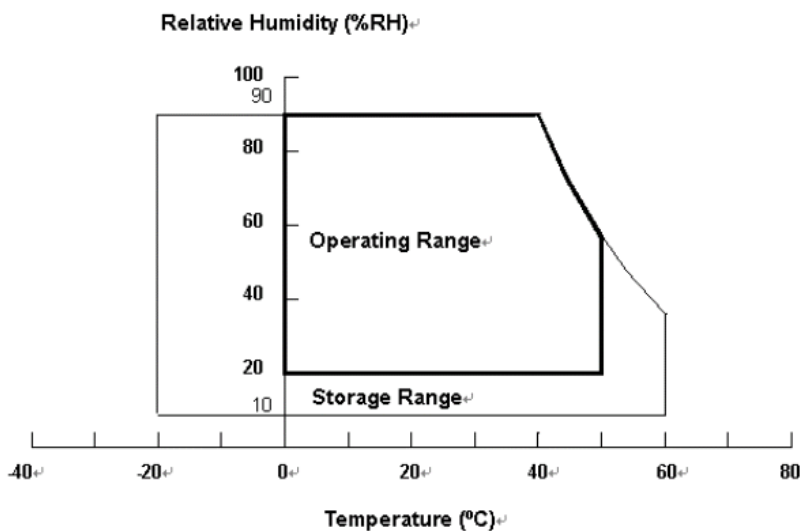

2.2 PACKAGE STORAGE

When storing modules as spares for a long time, the following precaution is necessary.

- (a) Do not leave the module in high temperature, and high humidity for a long time, It is highly recommended to store the module with temperature from 0 to 35 °C at normal humidity without condensation.
- (b) The module shall be stored in dark place. Do not store the TFT-LCD module in direct sunlight or fluorescent light.

2.3 ELECTRICAL ABSOLUTE RATINGS

2.3.1 TFT LCD MODULE

Item	Symbol	Value		Unit	Note
		Min.	Max.		
Power Supply Voltage	VCCI	-0.3	12.6	V	(1)
Logic Input Voltage	VIN	-0.3	3.6	V	

3. ELECTRICAL CHARACTERISTICS

3.1 TFT LCD MODULE

(Ta = 25 ± 2 °C)

Parameter	Symbol	Value			Unit	Note	
		Min.	Typ.	Max.			
Power Supply Voltage	V _{CC}	10.8	12	12.6	V	(1)	
Rush Current	I _{RUSH}	—	—	3.8	A	(2)	
Power Consumption	White Pattern	—	—	4.2	5.9	W	(3)
	Horizontal Stripe	—	—	7.68	10.8	W	
	Black Pattern	—	—	7.8	11	W	
Power Supply Current	White Pattern	—	—	0.35	0.5	A	
	Horizontal Stripe	—	—	0.64	0.9	A	
	Black Pattern	—	—	0.65	0.91	A	
LVDS interface	Differential Input High Threshold Voltage	V _{LVTH}	+100	—	—	mV	(4)
	Differential Input Low Threshold Voltage	V _{LVTL}	—	—	-100	mV	
	Common Input Voltage	V _{CM}	1.0	1.2	1.4	V	
	Differential input voltage (single-end)	V _{ID}	200	—	600	mV	
	Terminating Resistor	R _T	—	100	—	ohm	
CMIS interface	Input High Threshold Voltage	V _{IH}	2.7	—	3.3	V	
	Input Low Threshold Voltage	V _{IL}	0	—	0.7	V	

Note (1) The module should be always operated within the above ranges.

Note (2) Measurement condition:

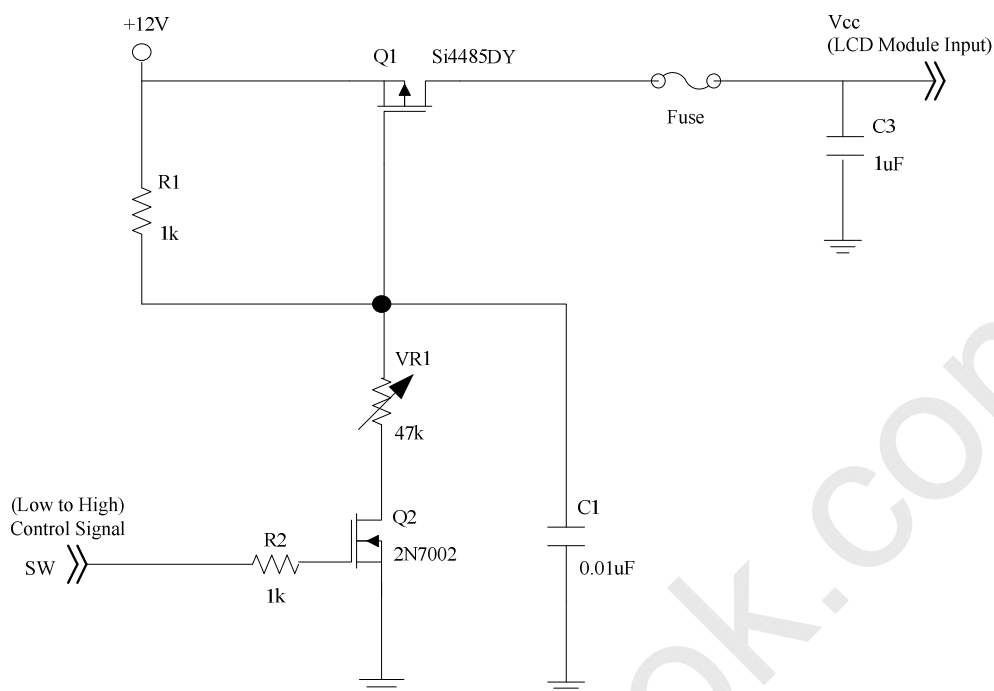

Vcc rising time is 470us

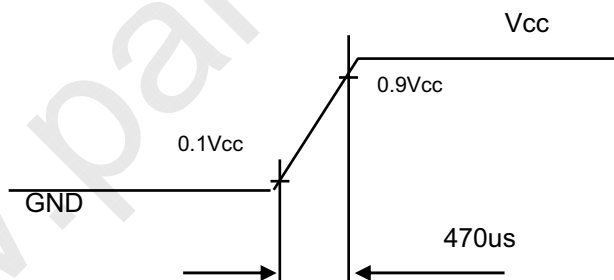

Note (3) The specified power consumption and power supply current is under the conditions at $V_{cc} = 12\text{ V}$, $T_a = 25 \pm 2\text{ }^\circ\text{C}$, $f_v = 120\text{ Hz}$, whereas a power dissipation check pattern below is displayed.

a. White Pattern



Active Area

b. Black Pattern

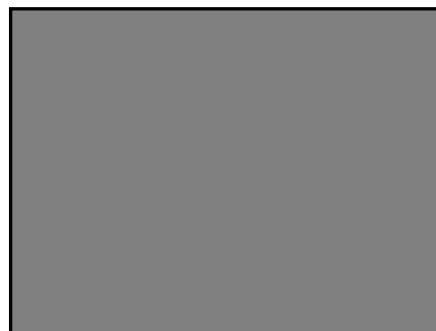

Active Area

c. Horizontal Stripe Pattern

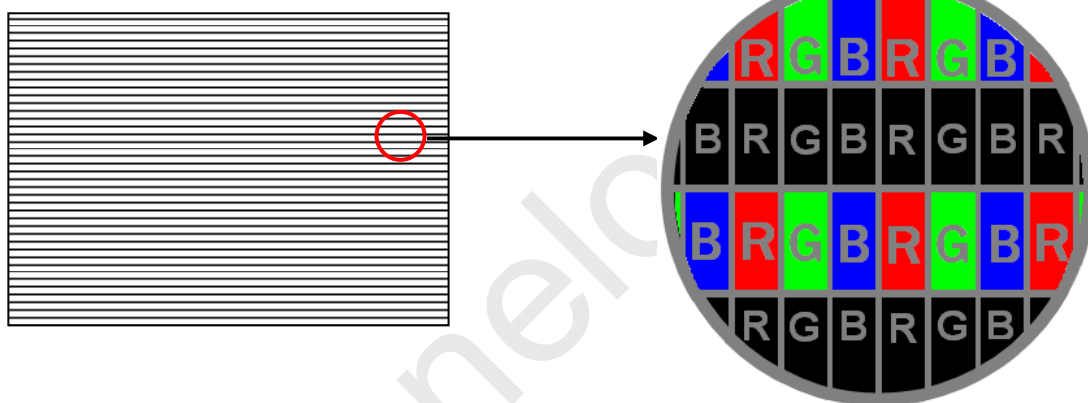

Note (4) The LVDS input characteristics are as follows:

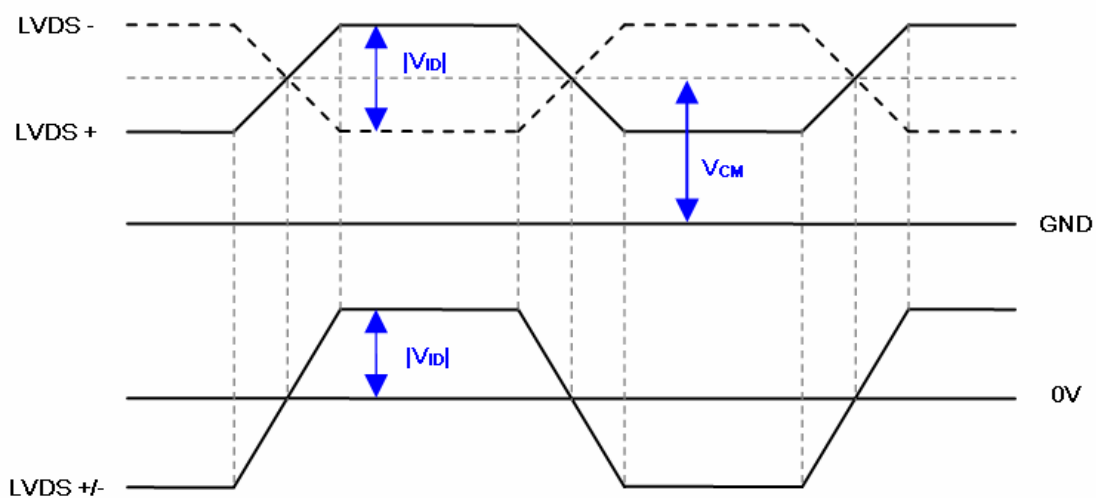

3.2 BACKLIGHT CONNECTOR PIN CONFIGURATION

3.2.1 LED LIGHT BAR CHARACTERISTICS

A. 2D/3D=Low level or Open (negative dimming)

(Ta = 25 ± 2 °C)

Parameter	Symbol	Value			Unit	Note
		Min.	Typ.	Max.		
Light Bar Voltage	V _W	33.6	38.4	42	V	(1), Duty=0%, I _{PIN} =60mA
LED Current	I _L	58.2	60	61.8	mA	(1), (2) Duty=0%
Power consumption	P _{BL}	---	13.83	15.57	W	(1) Duty=0%, I _{PIN} =60mA
Life time	-	30,000	-	-	Hrs	(3)

B. 2D/3D=High level (negative dimming, reference only)

Parameter	Symbol	Value			Unit	Note
		Min.	Typ.	Max.		
Light Bar Voltage	V _W	---	46.8	50.4	V	(1), Duty=0%, I _{PIN} =120mA
LED Current	I _L	---	120	125	mA	(1), (2) Duty=82% 120Hz
Power consumption	P _{BL}	---	6.1	6.8	W	(1) Duty=82%, I _{PIN} =120mA

Note (1) LED light bar input voltage and current are measured by utilizing a true RMS multimeter as shown below:

Note (2) $P_{BL} = I_{PIN} \times V_{PIN} \times (6)$ input pins, LED light bar circuit is (12)Series, (6)Parallel.

Note (3) The lifetime of LED is defined as the time when LED packages continue to operate under the conditions at Ta = 25 ± 2 °C and I = (20)mA (per chip) until the brightness becomes ≤ 50% of its original value.

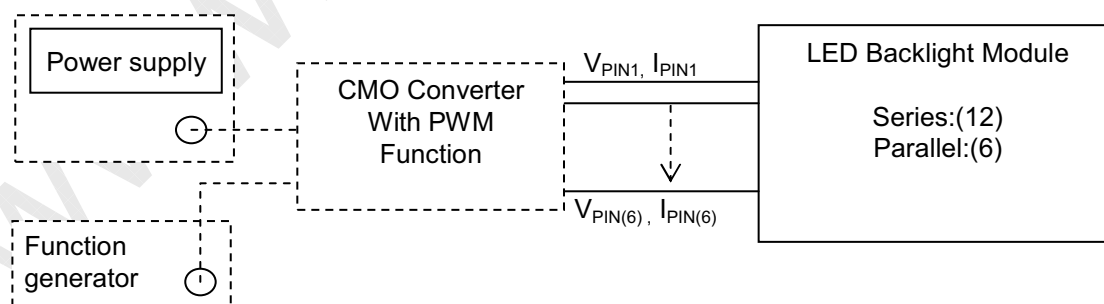

3.2.2 LIGHTBAR CONNECTOR PIN ASSIGNMENT

Connector: B-F,7083K-F12N-00L ,ENTERY(恩得利),

161035-12041-3 P-TWO (禾昌), GB5DH120-112M-7H,Foxconn(鴻海), or Compatible

(1) Input connector pin assignment: CN1

Pin No.	Symbol	Feature
1	NC	Not connection, this pin should be open
2	LED1	Cathode of LED string
3	LED2	Cathode of LED string
4	LED3	Cathode of LED string
5	NC	Not connection, this pin should be open
6	VLED (38.4V)	VLED
7	VLED (38.4V)	VLED
8	NC	Not connection, this pin should be open
9	LED4	Cathode of LED string
10	LED5	Cathode of LED string
11	LED6	Cathode of LED string
12	NC	Not connection, this pin should be open

3.3 LVDS INPUT SIGNAL SPECIFICATIONS

3.3.1 LVDS DATA MAPPING TABLE

LVDS Channel O0	LVDS output	D7	D6	D4	D3	D2	D1	D0
	Data order	OG0	OR5	OR4	OR3	OR2	OR1	OR0
LVDS Channel O1	LVDS output	D18	D15	D14	D13	D12	D9	D8
	Data order	OB1	OB0	OG5	OG4	OG3	OG2	OG1
LVDS Channel O2	LVDS output	D26	D25	D24	D22	D21	D20	D19
	Data order	DE	NA	NA	OB5	OB4	OB3	OB2
LVDS Channel O3	LVDS output	D23	D17	D16	D11	D10	D5	D27
	Data order	NA	OB7	OB6	OG7	OG6	OR7	OR6
LVDS Channel E0	LVDS output	D7	D6	D4	D3	D2	D1	D0
	Data order	EG0	ER5	ER4	ER3	ER2	ER1	ER0
LVDS Channel E1	LVDS output	D18	D15	D14	D13	D12	D9	D8
	Data order	EB1	EB0	EG5	EG4	EG3	EG2	EG1
LVDS Channel E2	LVDS output	D26	D25	D24	D22	D21	D20	D19
	Data order	DE	NA	NA	EB5	EB4	EB3	EB2
LVDS Channel E3	LVDS output	D23	D17	D16	D11	D10	D5	D27
	Data order	NA	EB7	EB6	EG7	EG6	ER7	ER6

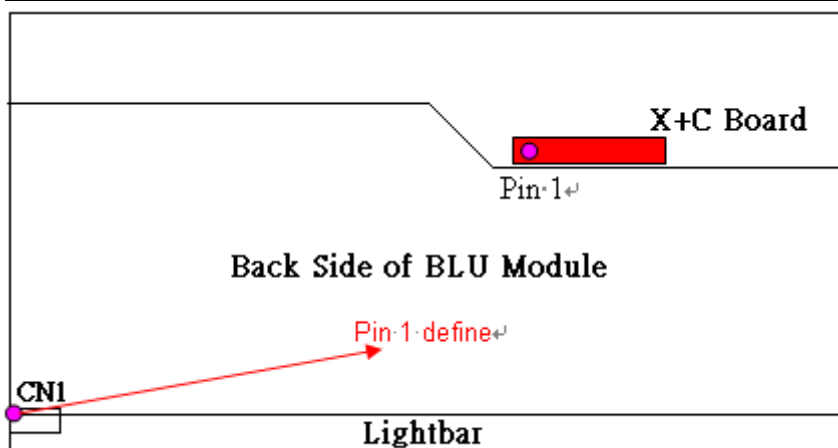

4. BLOCK DIAGRAM OF INTERFACE

4.1 TFT LCD MODULE

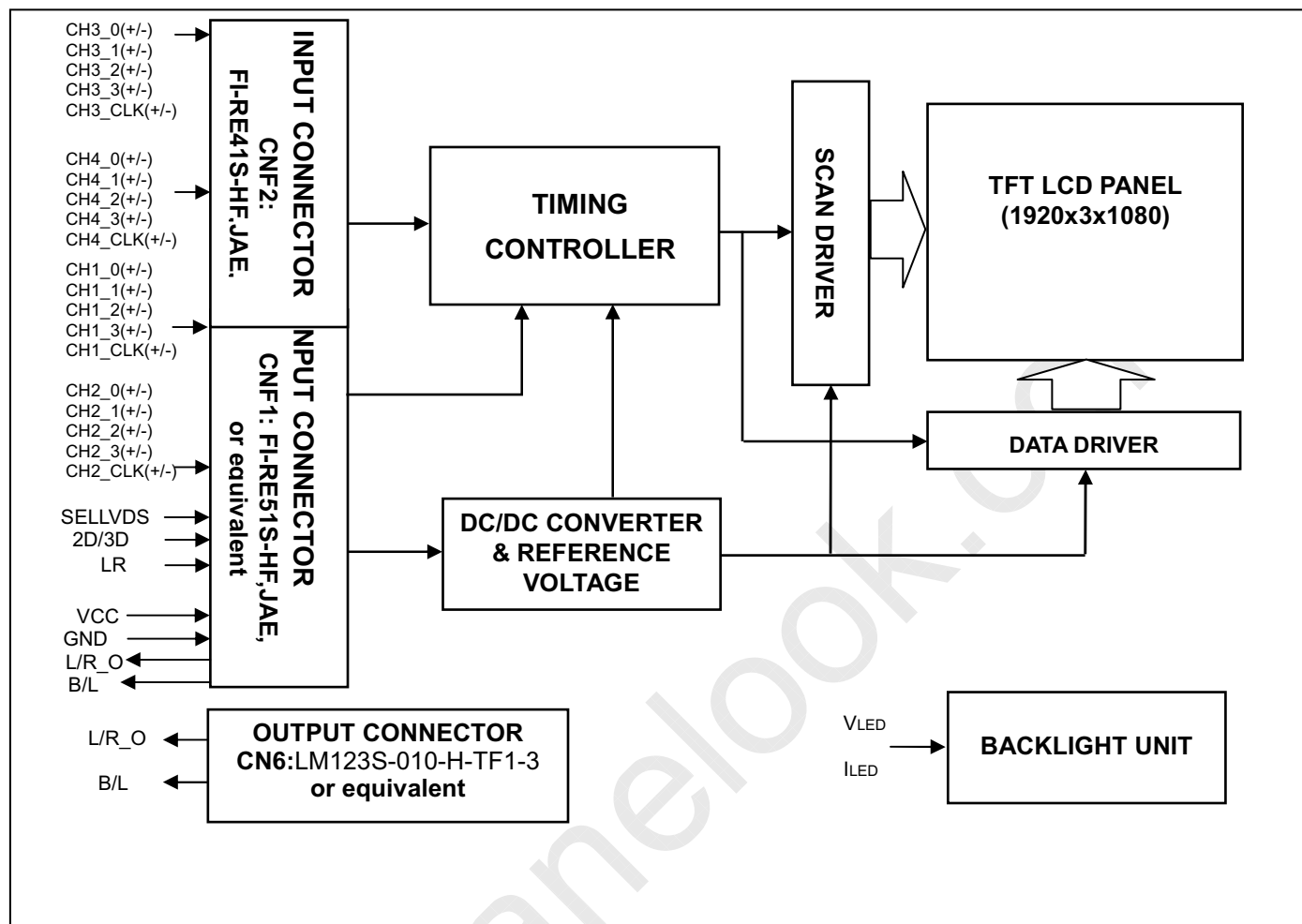

5. INPUT TERMINAL PIN ASSIGNMENT

5.1 TFT LCD MODULE INPUT

CNF1 Connector Pin Assignment: (FI-RE51S-HF(JAE) or equivalent)

Pin	Name	Description	Note
1	N.C.	No Connection	(1)
2	N.C.	No Connection	
3	N.C.	No Connection	
4	N.C.	No Connection	
5	L/R_O	Output signal for Left Right Glasses control	(7)
6	B/L	Output signal for backlight on/off control signal , H: B/L off, L: B/L on (3D only)	H: +3.3V L: 0V
7	SELLVDS	LVDS Data Format Selection	(2)(6)
8	N.C.	No Connection	(1)
9	N.C.	No Connection	
10	N.C.	No Connection	
11	GND	Ground	
12	CH1[0]-	First pixel Negative LVDS differential data input. Pair 0	
13	CH1[0]+	First pixel Positive LVDS differential data input. Pair 0	
14	CH1[1]-	First pixel Negative LVDS differential data input. Pair 1	
15	CH1[1]+	First pixel Positive LVDS differential data input. Pair 1	
16	CH1[2]-	First pixel Negative LVDS differential data input. Pair 2	
17	CH1[2]+	First pixel Positive LVDS differential data input. Pair 2	
18	GND	Ground	
19	CH1CLK-	First pixel Negative LVDS differential clock input.	
20	CH1CLK+	First pixel Positive LVDS differential clock input.	
21	GND	Ground	
22	CH1[3]-	First pixel Negative LVDS differential data input. Pair 3	
23	CH1[3]+	First pixel Positive LVDS differential data input. Pair 3	
24	N.C.	No Connection	
25	N.C.	No Connection	
26	2D/3D	Input signal for 2D/3D Mode Selection	(3)(5)
27	LR	Input signal for Left Right eye frame synchronous	(4)(5)
28	CH2[0]-	Second pixel Negative LVDS differential data input. Pair 0	

29	CH2[0]+	Second pixel Positive LVDS differential data input. Pair 0	
30	CH2[1]-	Second pixel Negative LVDS differential data input. Pair 1	
31	CH2[1]+	Second pixel Positive LVDS differential data input. Pair 1	
32	CH2[2]-	Second pixel Negative LVDS differential data input. Pair 2	
33	CH2[2]+	Second pixel Positive LVDS differential data input. Pair 2	
34	GND	Ground	
35	CH2CLK-	Second pixel Negative LVDS differential clock input.	
36	CH2CLK+	Second pixel Positive LVDS differential clock input.	
37	GND	Ground	
38	CH2[3]-	Second pixel Negative LVDS differential data input. Pair 3	
39	CH2[3]+	Second pixel Positive LVDS differential data input. Pair 3	
40	N.C.	No Connection	
41	N.C.	No Connection	
42	NC	No Connection	
43	N.C.	No Connection	(1)
44	GND	Ground	
45	GND	Ground	
46	GND	Ground	
47	N.C.	No Connection	(1)
48	VCC	+12V power supply	
49	VCC	+12V power supply	
50	VCC	+12V power supply	
51	VCC	+12V power supply	

CNF2 Connector Pin Assignment (FI-RE41S-HF (JAE) or equivalent)

Pin	Name	Description	Note
1	N.C.	No Connection	(1)
2	N.C.	No Connection	
3	N.C.	No Connection	
4	N.C.	No Connection	
5	N.C.	No Connection	
6	N.C.	No Connection	
7	N.C.	No Connection	
8	N.C.	No Connection	
9	GND	Ground	
10	CH3[0]-	Third pixel Negative LVDS differential data input. Pair 0	
11	CH3[0]+	Third pixel Positive LVDS differential data input. Pair 0	
12	CH3[1]-	Third pixel Negative LVDS differential data input. Pair 1	
13	CH3[1]+	Third pixel Positive LVDS differential data input. Pair 1	
14	CH3[2]-	Third pixel Negative LVDS differential data input. Pair 2	
15	CH3[2]+	Third pixel Positive LVDS differential data input. Pair 2	
16	GND	Ground	
17	CH3CLK-	Third pixel Negative LVDS differential clock input.	
18	CH3CLK+	Third pixel Positive LVDS differential clock input.	
19	GND	Ground	
20	CH3[3]-	Third pixel Negative LVDS differential data input. Pair 3	
21	CH3[3]+	Third pixel Positive LVDS differential data input. Pair 3	
22	N.C.	No Connection	
23	N.C.	No Connection	
24	GND	Ground	
25	GND	Ground	
26	CH4[0]-	Fourth pixel Negative LVDS differential data input. Pair 0	
27	CH4[0]+	Fourth pixel Positive LVDS differential data input. Pair 0	
28	CH4[1]-	Fourth pixel Negative LVDS differential data input. Pair 1	
29	CH4[1]+	Fourth pixel Positive LVDS differential data input. Pair 1	
30	CH4[2]-	Fourth pixel Negative LVDS differential data input. Pair 2	

31	CH4[2]+	Fourth pixel Positive LVDS differential data input. Pair 2	
32	GND	Ground	
33	CH4CLK-	Fourth pixel Negative LVDS differential clock input.	
34	CH4CLK+	Fourth pixel Positive LVDS differential clock input.	
35	GND	Ground	
36	CH4[3]-	Fourth pixel Negative LVDS differential data input. Pair 3	
37	CH4[3]+	Fourth pixel Positive LVDS differential data input. Pair 3	
38	N.C.	No Connection	
39	N.C.	No Connection	
40	GND	Ground	
41	GND	Ground	

CN6 Connector Pin Assignment (LM123S-010-H-TF1-3 (UNE) or equivalent)

1	N.C.	No Connection	
2	N.C.	No Connection	
3	N.C.	No Connection	
4	GND	Ground	
5	B/L	Output signal for backlight on/off control signal , H: B/L off, L: B/L on (3D only)	H: +3.3V L: 0V
6	L/R_O	Output signal for Left Right Glasses control	(7)
7	N.C.	No Connection	
8	N.C.	No Connection	
9	N.C.	No Connection	
10	N.C.	No Connection	

Note (1) Reserved for internal use. Please leave it open.

Note (2) LVDS format selection.

L= Connect to GND , H=Connect to +3.3V or Open

SELLVDS	Note
L	JEDIA Format
H or Open	VESA Format

Note (3) 2D/3D mode selection.

L= Connect to GND or Open, H=Connect to +3.3V

2D/3D	Note
L or Open	2D Mode
H	3D Mode

Note (4) Left Right synchronous signal for glasses.

$$V_{IL}=0\sim 0.8\text{ V}, V_{IH}=2.0\sim 3.3\text{ V}$$

LR	Note
L	Right synchronous signal
H	Left synchronous signal

Note (5) 2D/3D, and LR signal pin connected to the LCM side has the following diagram.

R1 in the system side should be less than 1K Ohm. ($R1 < 1K\text{ Ohm}$)

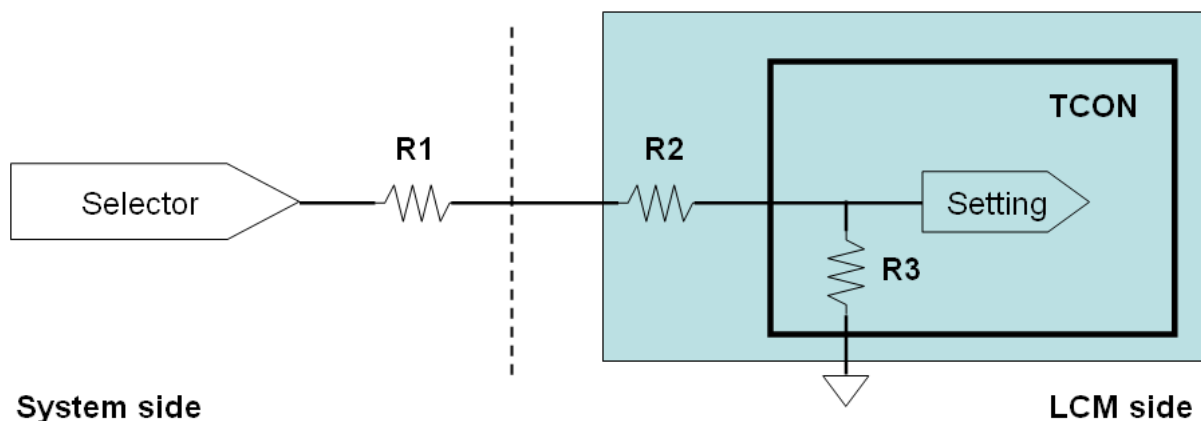

System side: $R1 < 1K$

Note (6) SELLVDS signal pin connected to the LCM side has the following diagram.

R1 in the system side should be less than 1K Ohm. ($R1 < 1K\text{ Ohm}$)

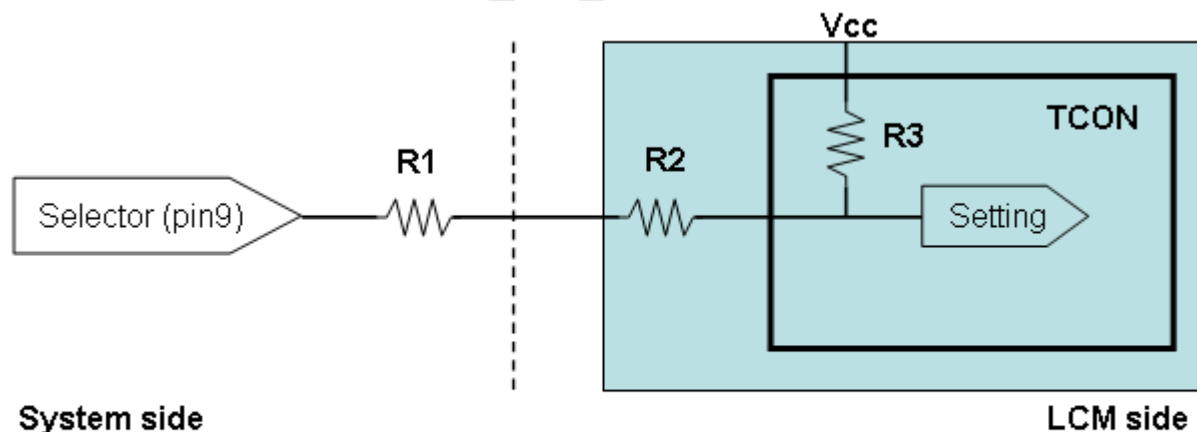

System side
 $R1 < 1K$

Note (7) The definition of L/R_O signal as follows

$$L=0\text{V}, H=+3.3\text{V}$$

L/R_O	Note
L	Right glass turn on
H	Left glass turn on

Note (8) LVDS 4-port Data Mapping

Port	Channel of LVDS	Data Stream
1st Port	First Pixel	1, 5, 9,1913, 1917
2nd Port	Second Pixel	2, 6, 10,1914, 1918
3rd Port	Third Pixel	3, 7, 11,1915, 1919
4th Port	Fourth Pixel	4, 8, 12,1916, 1920

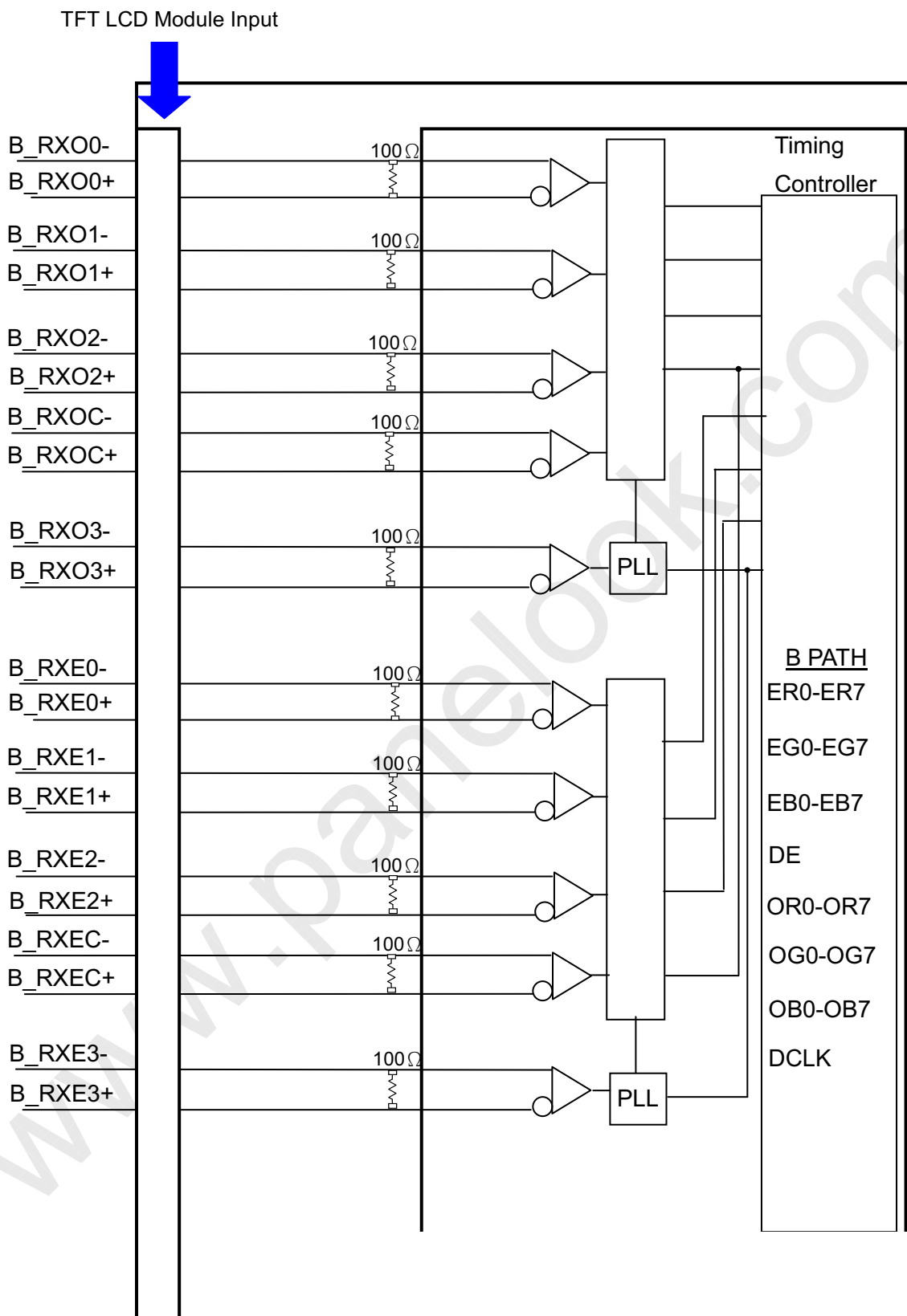
5.2 BLOCK DIAGRAM OF INTERFACE

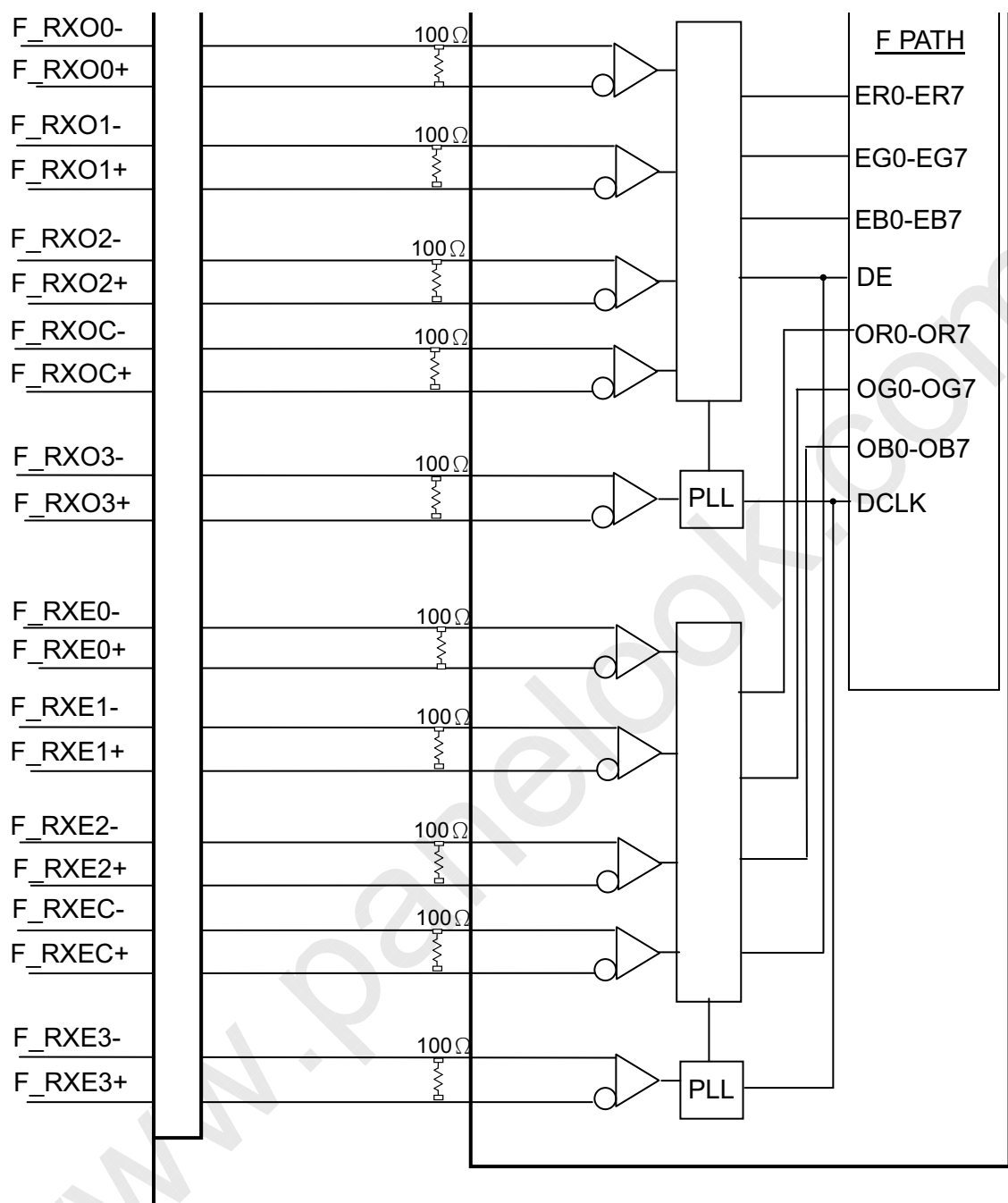

ER0~ER7	Even pixel R data	OR0~OR7	Odd pixel R data
EG0~EG7	Even pixel G data	OG0~OG7	Odd pixel G data
EB0~EB7	Even pixel B data	OB0~OB7	Odd pixel B data
		DE	Data enable signal
		DCLK	Data clock signal

Note (1) The system must have the transmitter to drive the module.

Note (2) LVDS cable impedance shall be 50 ohms per signal line or about 100 ohms per twist-pair line when it is used differentially.

Note (3) Two pixel data send into the module for every clock cycle. The first pixel of the frame is odd pixel and the second pixel is even pixel.

5.3 LVDS INTERFACE

JEIDA Format : SELLVDS = L

VESA Format : SELLVDS = H or Open

JEDIA Format

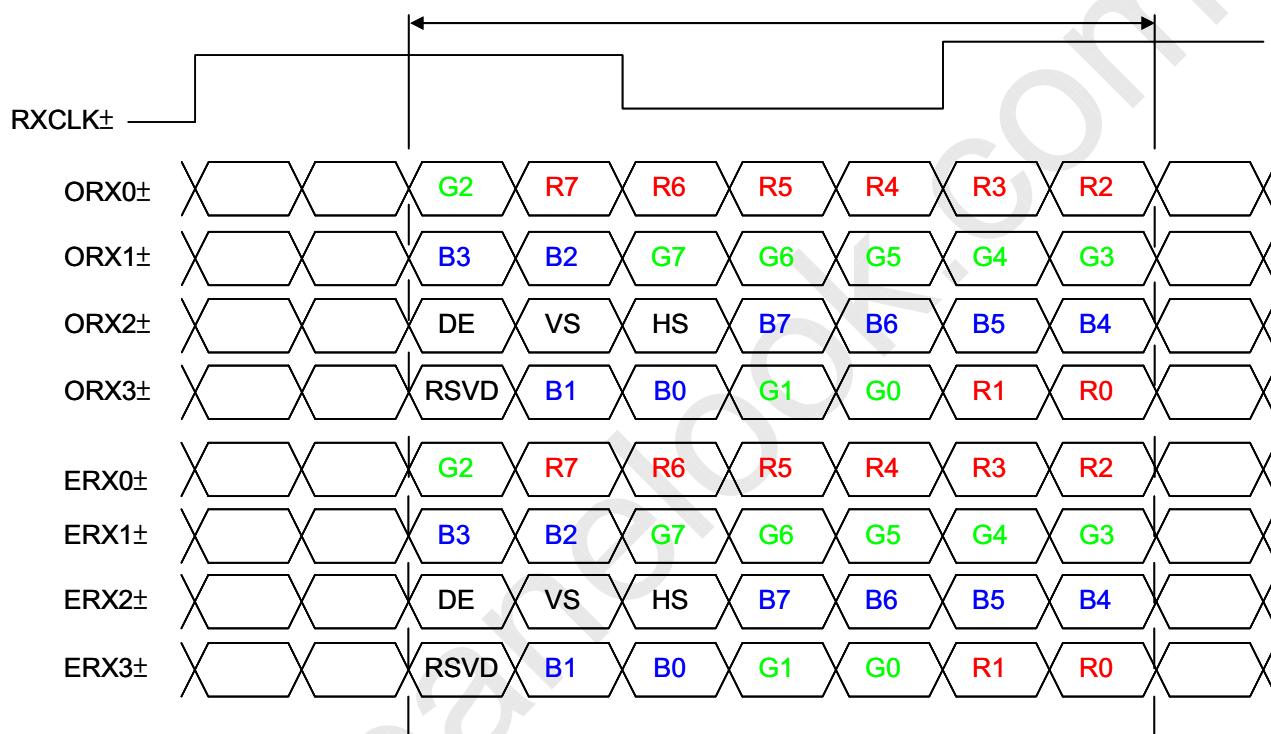

VESA Format

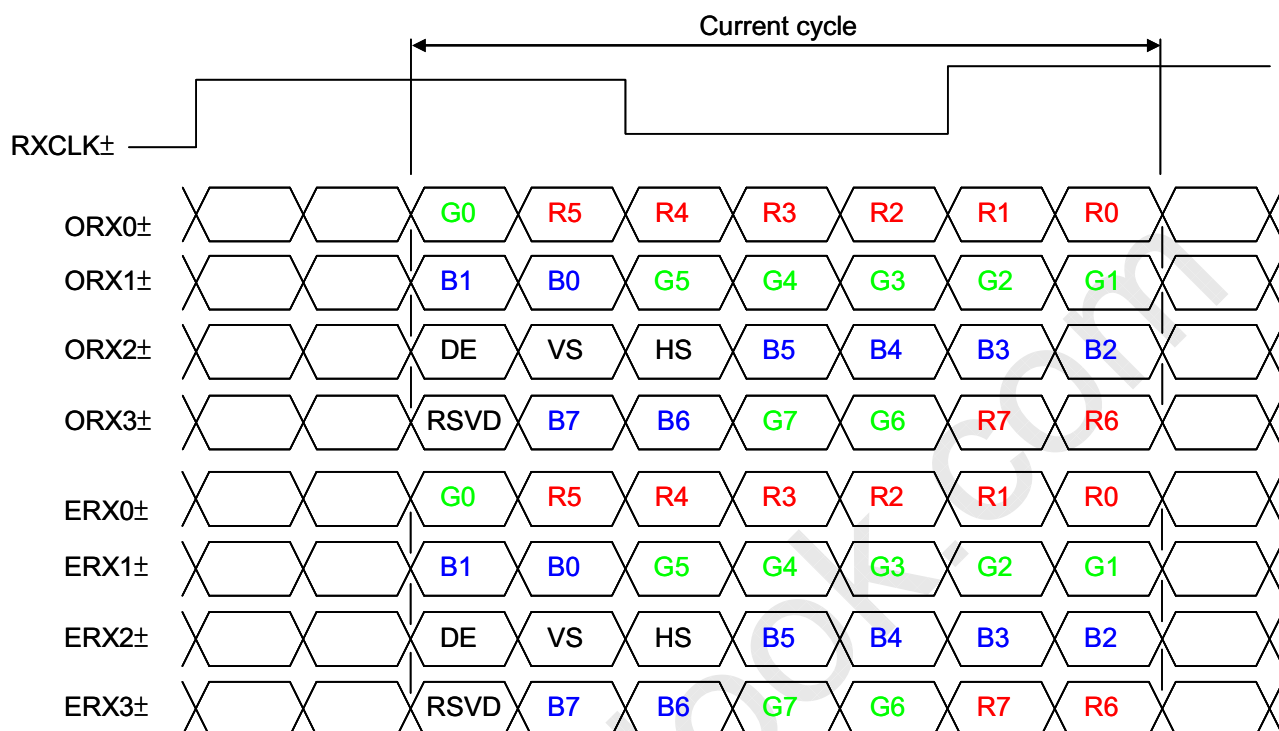

R0~R7: Pixel R Data (7; MSB, 0; LSB)

G0~G7: Pixel G Data (7; MSB, 0; LSB)

B0~B7: Pixel B Data (7; MSB, 0; LSB)

DE : Data enable signal

DCLK : Data clock signal

Notes (1) RSVD (reserved) pins on the transmitter shall be "H" or "L".

5.4 COLOR DATA INPUT ASSIGNMENT

The brightness of each primary color (red, green and blue) is based on the 8-bit gray scale data input for the color. The higher the binary input, the brighter the color. The table below provides the assignment of color versus data input.

Color		Data Signal																							
		Red								Green								Blue							
		R7	R6	R5	R4	R3	R2	R1	R0	G7	G6	G5	G4	G3	G2	G1	G0	B7	B6	B5	B4	B3	B2	B1	B0
Basic Colors	Black	0	0	0	0	0	0	0	0	0	0	0	0	0	0	0	0	0	0	0	0	0	0	0	0
	Red	1	1	1	1	1	1	1	1	0	0	0	0	0	0	0	0	0	0	0	0	0	0	0	0
	Green	0	0	0	0	0	0	0	0	1	1	1	1	1	1	1	1	0	0	0	0	0	0	0	0
	Blue	0	0	0	0	0	0	0	0	0	0	0	0	0	0	0	0	1	1	1	1	1	1	1	1
	Cyan	0	0	0	0	0	0	0	0	1	1	1	1	1	1	1	1	1	1	1	1	1	1	1	1
	Magenta	1	1	1	1	1	1	1	1	0	0	0	0	0	0	0	0	1	1	1	1	1	1	1	1
	Yellow	1	1	1	1	1	1	1	1	1	1	1	1	1	1	1	1	0	0	0	0	0	0	0	0
	White	1	1	1	1	1	1	1	1	1	1	1	1	1	1	1	1	1	1	1	1	1	1	1	1

6. INTERFACE TIMING

6.1 INPUT SIGNAL TIMING SPECIFICATIONS

($T_a = 25 \pm 2^\circ\text{C}$)

The input signal timing specifications are shown as the following table and timing diagram.

Signal	Item	Symbol	Min.	Typ.	Max.	Unit	Note
LVDS Receiver Clock	Frequency	$F_{\text{clkkin}} (=1/TC)$	60	74.25	96.23	MHz	
	Input cycle to cycle jitter	T_{rcj}	-	-	200	ps	(3)
	Spread spectrum modulation range	$F_{\text{clkkin_mod}}$	$F_{\text{clkkin}}-2\%$	-	$F_{\text{clkkin}}+2\%$	MHz	(4)
	Spread spectrum modulation frequency	F_{SSM}	-	-	200	KHz	
LVDS Receiver Data	Setup Time	T_{lvsv}	600	-	-	ps	(5)
	Hold Time	T_{lvhd}	600	-	-	ps	

6.1.1 TIMING SPEC FOR FRAME RATE ($F_{r5} = 100\text{Hz}$)

Vertical Active Display Term	2D Mode	Total	T_v	1115	1125	1135	T_h	$T_v=T_{vd}+T_{vb}$
		Display	T_{vd}	1080	1080	1080	T_h	-
		Blank	T_{vb}	35	45	55	T_h	-
	3D Mdoe	Total	T_v	1524			T_h	(6)
		Display	T_{vd}	1080			T_h	
		Blank	T_{vb}	444			T_h	
Horizontal Active Display Term	2D Mode	Total	T_h	540	550	575	T_c	$T_h=T_{hd}+T_{hb}$
		Display	T_{hd}	480	480	480	T_c	-
		Blank	T_{hb}	60	70	95	T_c	-
	3D Mdoe	Total	T_h	525			T_c	(7)
		Display	T_{hd}	480			T_c	
		Blank	T_{hb}	45			T_c	

6.1.2 TIMING SPEC FOR FRAME RATE ($F_{r6} = 120\text{Hz}$)

Vertical Active Display Term	2D Mode	Total	T_v	1115	1125	1135	T_h	$T_v=T_{vd}+T_{vb}$
		Display	T_{vd}	1080	1080	1080	T_h	-
		Blank	T_{vb}	35	45	55	T_h	-
	3D Mdoe	Total	T_v	1524			T_h	(6)

		Display	Tvd	1080			Th	
		Blank	Tvb	444			Th	
Horizontal Active Display Term	2D Mode	Total	Th	540	550	575	Tc	Th=Thd+Thb
		Display	Thd	480	480	480	Tc	—
		Blank	Thb	60	70	95	Tc	—
	3D Mdoe	Total	Th	525			Tc	(7)
		Display	Thd	480			Tc	
		Blank	Thb	45			Tc	

Note (1) Since the module is operated in DE only mode, Hsync and Vsync input signals should be set to low logic level. Otherwise, this module would operate abnormally.

Note (2) Please make sure the range of pixel clock has follow the below equation:

$$F_{clk(in)(max)} \geq Fr_6 \times Tv \times Th$$

$$Fr_5 \times Tv \times Th \geq F_{clk(in)(min)}$$

INPUT SIGNAL TIMING DIAGRAM

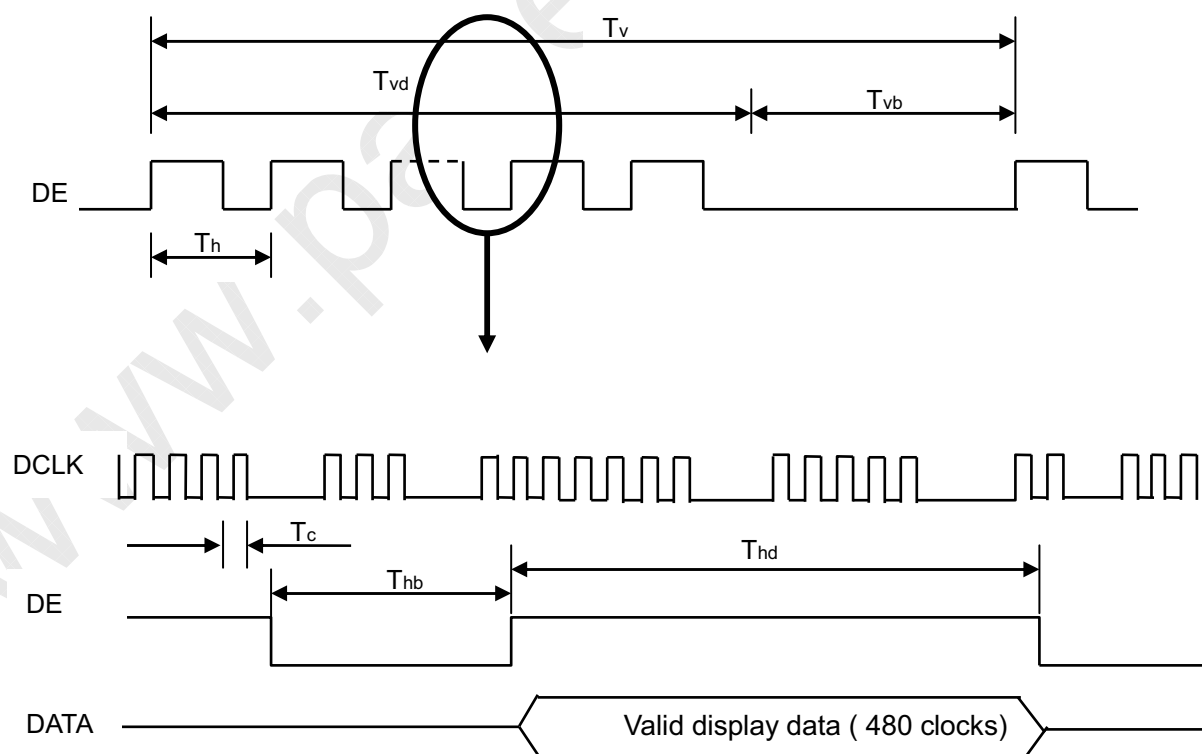

Note (3) The input clock cycle-to-cycle jitter is defined as below figures. $Trcl = |T_1 - T_1|$

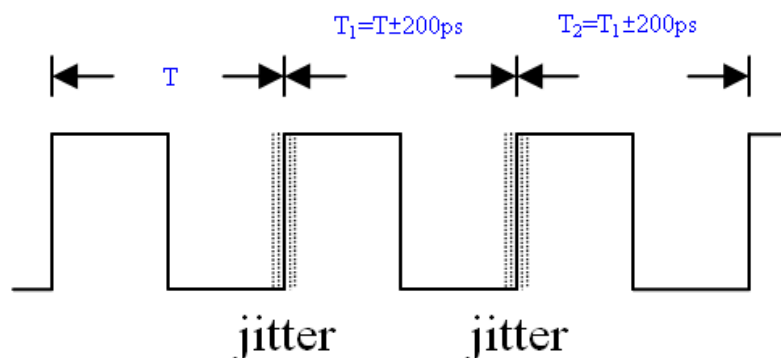

Note (4) The SSCG (Spread spectrum clock generator) is defined as below figures.

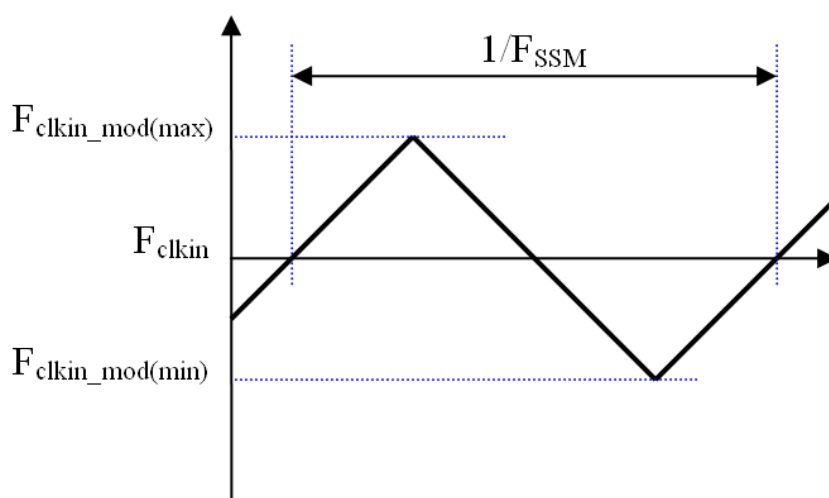

Note (5) The LVDS timing diagram and setup/hold time is defined and showing as the following figures.

LVDS RECEIVER INTERFACE TIMING DIAGRAM

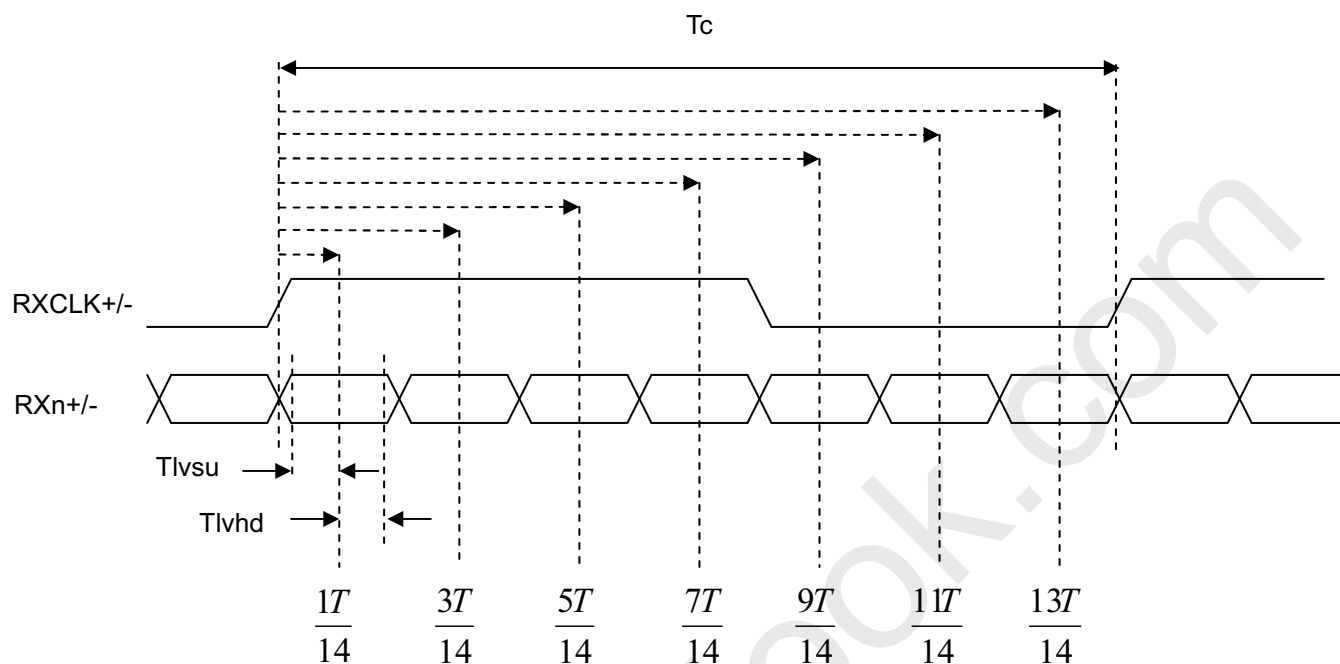

Note (6) Please fix the Vertical timing (Vertical Total = 1524 / Display = 1080 / Blank = 444) in 3D mode.

Note (7) Please fix the Horizontal timing (Horizontal Total = 2100 / Display = 1920 / Blank = 180) in 3D mode

6.2 POWER ON/OFF SEQUENCE
6.2.1 POWER ON/OFF SEQUENCE ($T_a = 25 \pm 2 \text{ }^\circ\text{C}$)

To prevent a latch-up or DC operation of LCD module, the power on/off sequence should be as the diagram below.

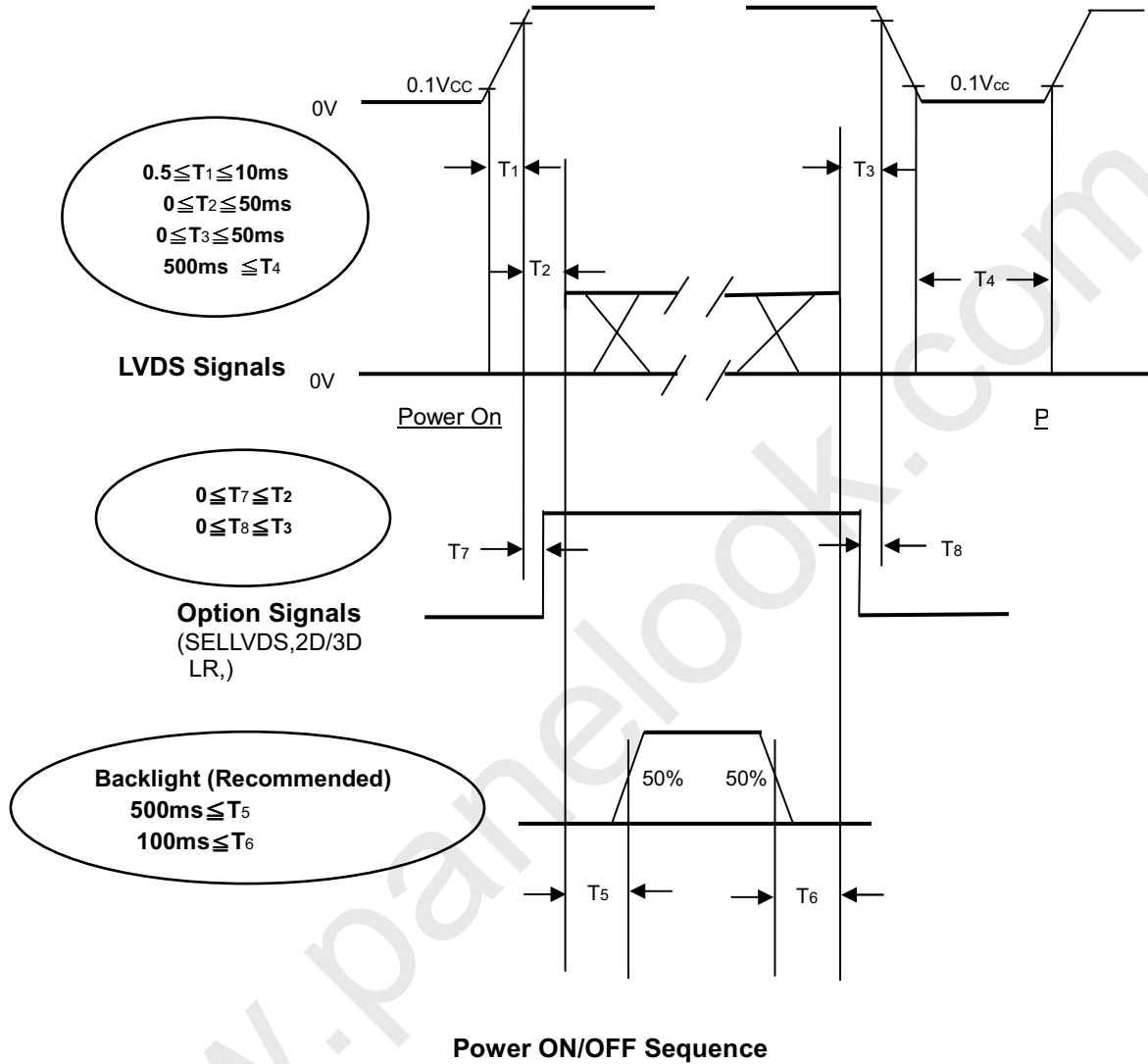
Power ON/OFF Sequence

6.2.2 2D to 3D SIGNAL SEQUENCE WITHOUT VCC TURN OFF AND TURN ON

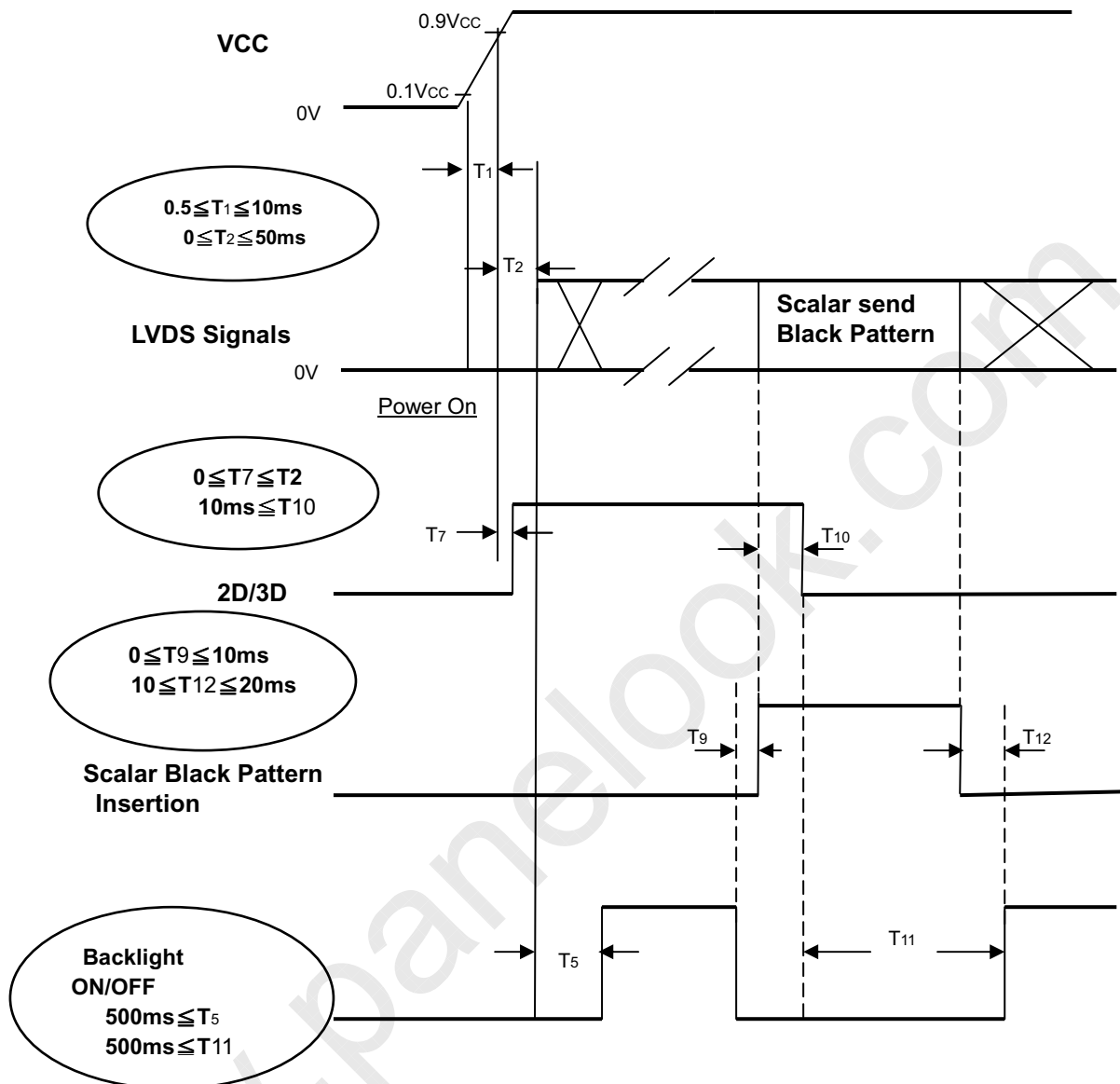

Note (1) The supply voltage of the external system for the module input should follow the definition of V_{CC}.

Note (2) Apply the LED voltage within the LCD operation range. When the backlight turns on before the LCD operation or the LCD turns off before the backlight turns off, the display may momentarily become abnormal screen.

Note (3) In case of V_{CC} is in off level, please keep the level of input signals on the low or high impedance. If T₂<0, that maybe cause electrical overstress failure.

Note (4) T₄ should be measured after the module has been fully discharged between power off and on period.

Note (5) Interface signal shall not be kept at high impedance when the power is on.

7. OPTICAL CHARACTERISTICS

7.1 TEST CONDITIONS

Item	Symbol	Value	Unit
Ambient Temperature	Ta	25±2	oC
Ambient Humidity	Ha	50±10	%RH
Supply Voltage	VCC	12	V
Input Signal	According to typical value in "3. ELECTRICAL CHARACTERISTICS"		
LED Current	IL	60 ± 1.2	mA
Vertical Frame Rate	Fr	120	Hz

The LCD module should be stabilized at given temperature for 1 hour to avoid abrupt temperature change during measuring. In order to stabilize the luminance, the measurement should be executed after lighting backlight for 1 hour in a windless room.

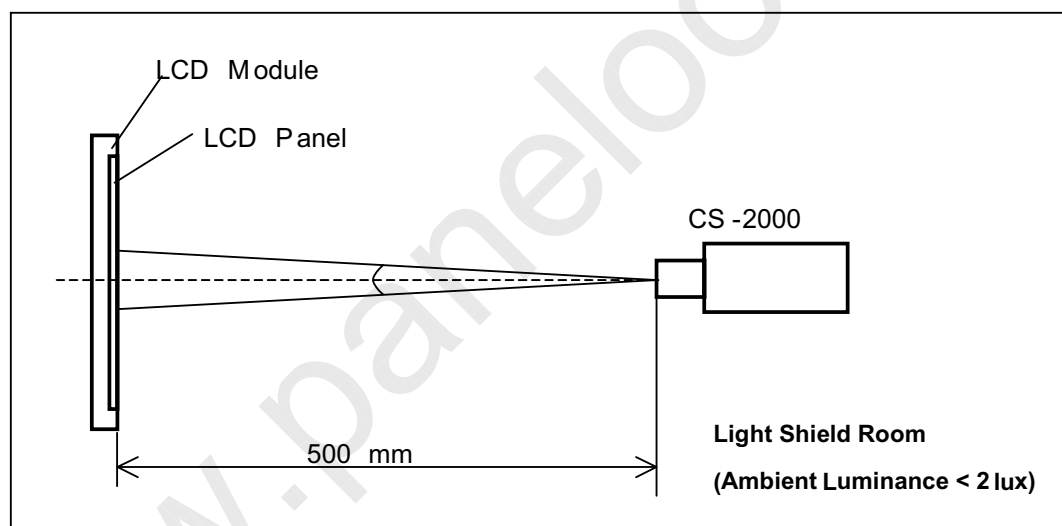

7.2 OPTICAL SPECIFICATIONS

The relative measurement methods of optical characteristics are shown in 7.2. The following items should be measured under the test conditions described in 7.1 and stable environment shown in 7.1.

Item	Symbol	Condition	Min.	Typ.	Max.	Unit	Note				
Contrast Ratio	CR		700	1000	-	-	(2)				
Response Time (TN)	T_R		-	0.8	2.5	ms	(3)				
	T_F		-	2.8	5.5						
Center Luminance of White	L_C	2D	250	300	-	cd/m ²	(4)				
		3D	-	26	-	cd/m ²	(8)				
White Variation	δW		-	-	1.33	-	(6)				
Cross Talk	CT	2D	-	-	4	%	(5)				
		3D-W	-	0.4	-	%	(8)				
		3D-D	-	12	-	%	(8)				
Color Chromaticity	Red	R_x	$\theta_x=0^\circ, \theta_y=0^\circ$ Viewing angle at normal direction	0.634	Typ. -0.03	Typ. +0.03	-	-			
		R_y		0.338			-				
	Green	G_x		0.306			-				
		G_y		0.619			-				
	Blue	B_x		0.155			-				
		B_y		0.056			-				
	White	W_x		0.285			-				
		W_y		0.293			-				
	Correlated color temperature			-			9300		-	K	-
	Color Gamut	C.G.		-			72		-	%	NTSC
Viewing Angle	Horizontal	θ_{x+}	CR \geq 10	75	85	-	Deg.	(1)			
		θ_{x-}		75	85	-					
	Vertical	θ_{y+}		70	80	-					
		θ_{y-}		70	80	-					
Transmission direction of the up polarizer	Φ_{up}	-	-	45	-	Deg.	(7)				

Note (1) Definition of Viewing Angle (θ_x, θ_y):

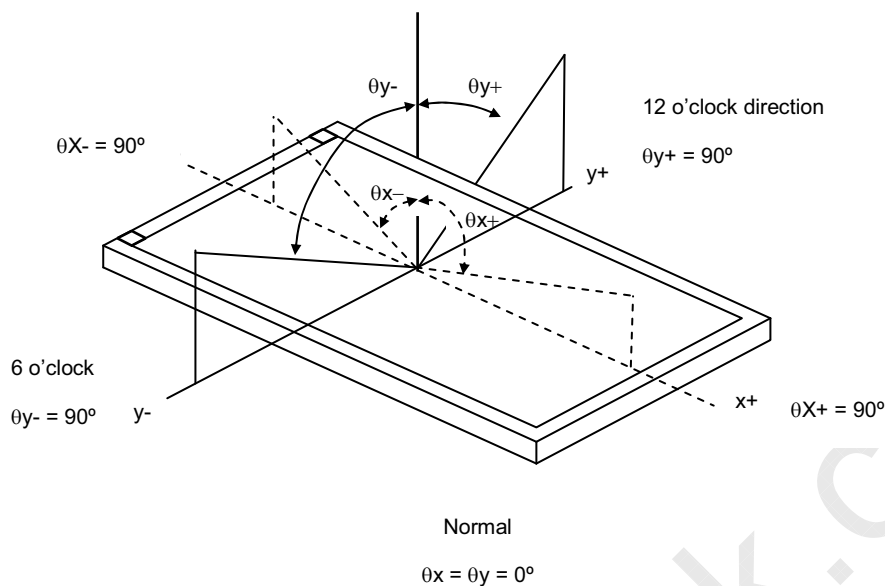

Note (2) Definition of Contrast Ratio (CR):

The contrast ratio can be calculated by the following expression.

$$\text{Contrast Ratio (CR)} = \frac{\text{Surface Luminance of L255}}{\text{Surface Luminance of L0}}$$

L255: Luminance of gray level 255

L 0: Luminance of gray level 0

CR = CR (5), where CR (X) is corresponding to the Contrast Ratio of the point X at the figure in Note (6).

Note (3) Definition of Response Time (T_R, T_F):

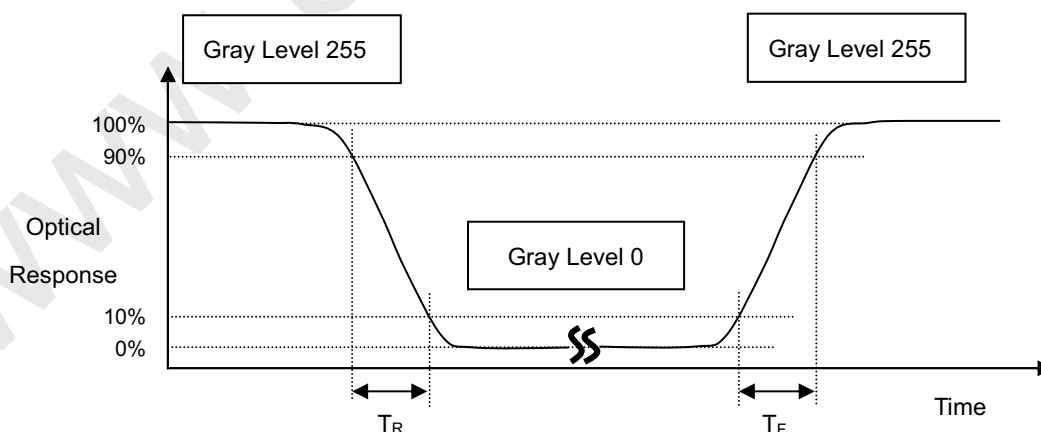

Note (4) Definition of Luminance of White (L_C):

Measure the luminance of gray level 255 at center point and 5 points

$L_C = L (5)$, where L (X) is corresponding to the luminance of the point X at the figure in Note (6).

Note (5) Definition of Cross Talk (CT):

$$CT = |Y_B - Y_A| / Y_A \times 100 (\%)$$

Where:

Y_A = Luminance of measured location without gray level 0 pattern (cd/m²)

Y_B = Luminance of measured location with gray level 0 pattern (cd/m²)

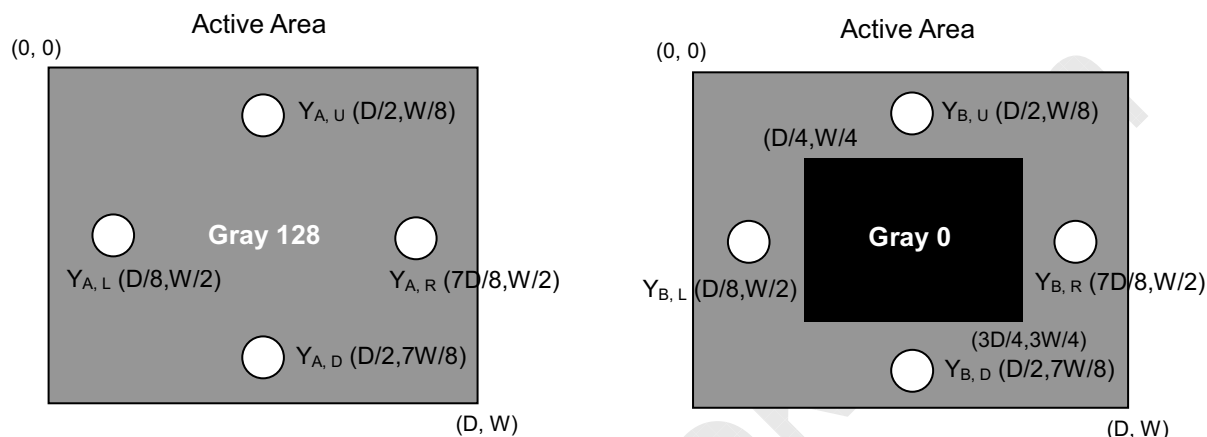

Note (6) Definition of White Variation (δW):

Measure the luminance of gray level 255 at 5 points

$$\delta W = \text{Maximum} [L(1), L(2), L(3), L(4), L(5)] / \text{Minimum} [L(1), L(2), L(3), L(4), L(5)]$$

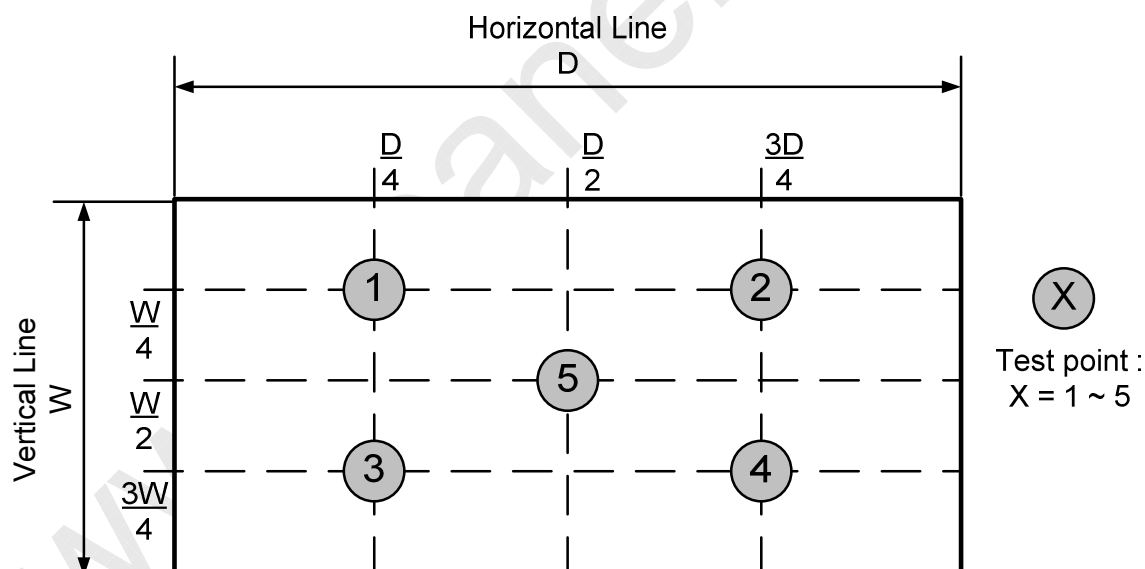

Note (7) This is a reference for designing the shutter glasses of 3D application. (TN case)

Definition of the absorption direction of the up polarizer:

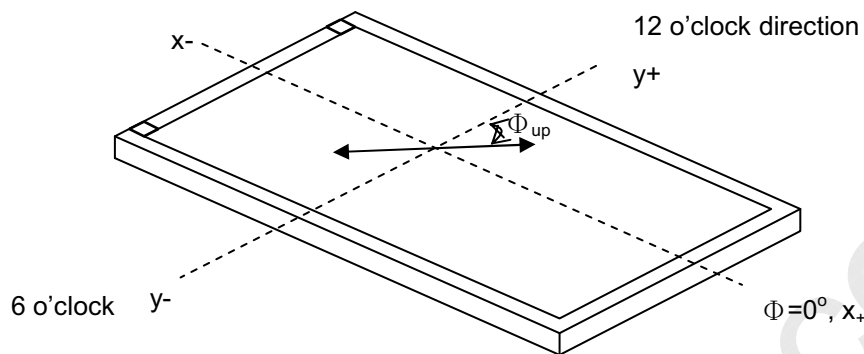



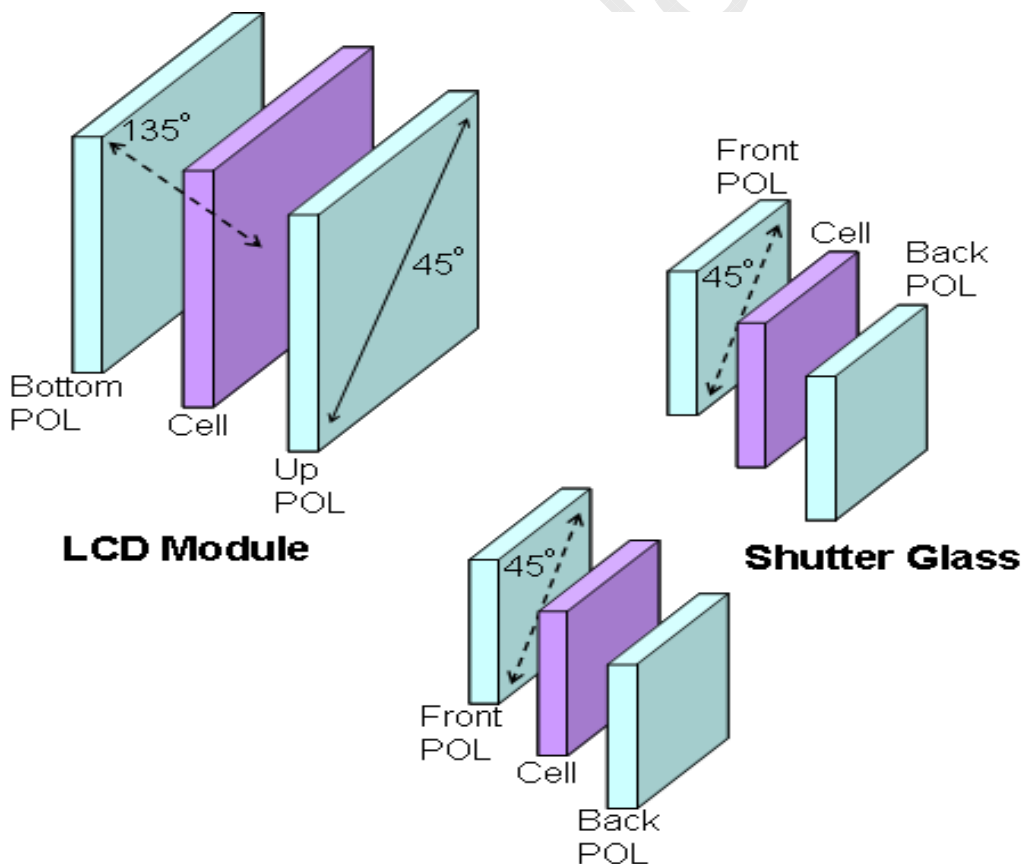





The absorption axis of the front polarizer of the shutter glasses should be parallel to this panel absorption direction to get a maximum 3D mode luminance.

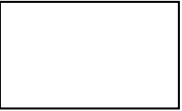

Note(8) Definition of the 3D mode performance (measured under 3D mode):

a. Test pattern

Left eye image and right eye image are displayed alternated

		W	Left eye image: W255; Right eye image: W255
		WB	Left eye image: W255; Right eye image: W0
		BW	Left eye image: W0; Right eye image: W255
		BB	Left eye image: W0; Right eye image: W0

b. Measurement setup

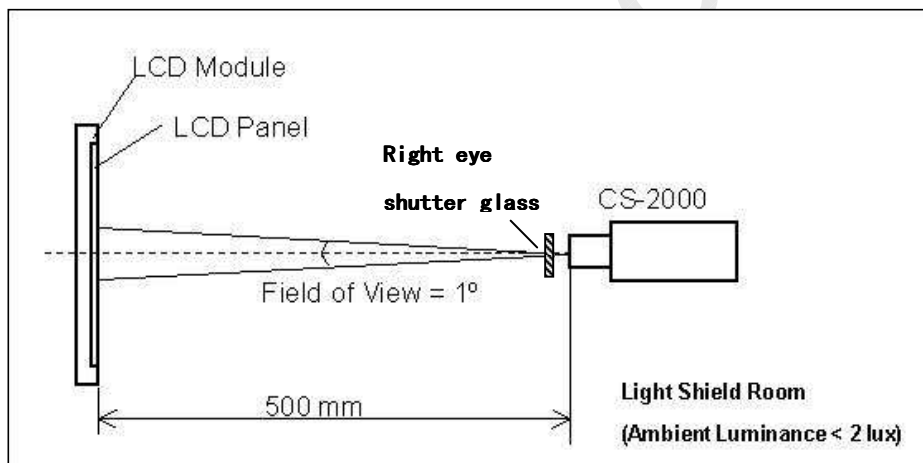

Shutter glasses are well controlled under suitable timing, and measure the luminance of the center point of the panel through the right eye glass. The transmittance of the glass should be larger than 40.0% under 3D mode operation.

The luminance of the test pattern "WW", denoted $L(WW)$; the luminance of the test pattern "WB", denoted $L(WB)$; the luminance of the test pattern "BW", denoted $L(BW)$; the luminance of the test pattern "BB", denoted $L(BB)$

c. Definition of the Center Luminance of White, L_c (3D) : $L(WW)$

d. Definition of the 3D mode white crosstalk, CT (3D-W) : $CT(3D-W) \equiv \frac{L(WB) - L(BB)}{L(WW) - L(BB)}$

e. Definition of the 3D mode dark crosstalk, CT (3D-D) : $CT(3D-D) \equiv \frac{L(WW) - L(BW)}{L(WW) - L(BB)}$

8. PRECAUTIONS

8.1 ASSEMBLY AND HANDLING PRECAUTIONS

- [1] Do not apply rough force such as bending or twisting to the module during assembly.
- [2] It is recommended to assemble or to install a module into the user's system in clean working areas. The dust and oil may cause electrical short or worsen the polarizer.
- [3] Do not apply pressure or impulse to the module to prevent the damage of LCD panel and Backlight.
- [4] Always follow the correct power-on sequence when the LCD module is turned on. This can prevent the damage and latch-up of the CMIS LSI chips.
- [5] Bezel of Set can not press or touch the panel surface. It will make light leakage or scrape.
- [6] Do not plug in or pull out the I/F connector while the module is in operation.
- [7] Do not disassemble the module.
- [8] Use a soft dry cloth without chemicals for cleaning, because the surface of polarizer is very soft and easily scratched.
- [9] Moisture can easily penetrate into LCD module and may cause the damage during operation.
- [10] When storing modules as spares for a long time, the following precaution is necessary.
 - [10.1] Do not leave the module in high temperature, and high humidity for a long time. It is highly recommended to store the module with temperature from 0 to 35°C at normal humidity without condensation.
 - [10.2] The module shall be stored in dark place. Do not store the TFT-LCD module in direct sunlight or fluorescent light.
- [11] When ambient temperature is lower than 10°C, the display quality might be reduced. For example, the response time will become slow, and the starting voltage of CCFL will be higher than that of room temperature.

8.2 SAFETY PRECAUTIONS

- [1] The startup voltage of a Backlight is approximately 1000 Volts. It may cause an electrical shock while assembling with the inverter. Do not disassemble the module or insert anything into the Backlight unit.
- [2] If the liquid crystal material leaks from the panel, it should be kept away from the eyes or mouth. In case of contact with hands, skin or clothes, it has to be washed away thoroughly with soap.
- [3] After the module's end of life, it is not harmful in case of normal operation and storage.

9. DEFINITION OF LABELS

9.1 CMI MODULE LABEL

The barcode nameplate is pasted on each module as illustration, and its definitions are as following explanation.

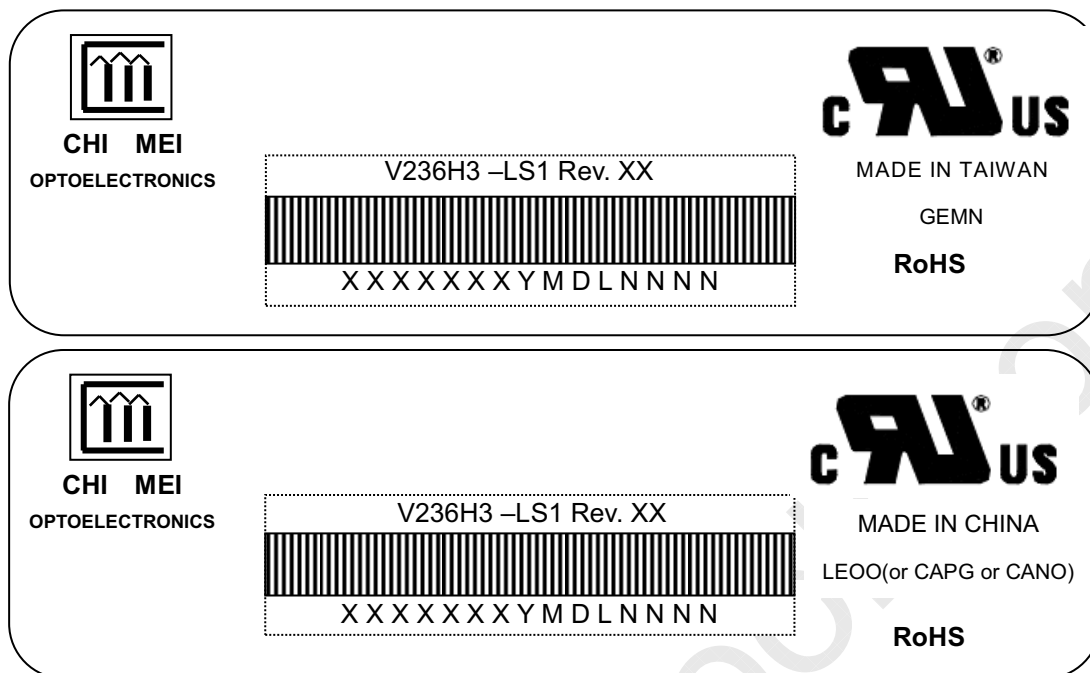

Model Name: V236H3 -LS1

Revision: Rev. XX, for example: A0, A1... B1, B2... or C1, C2...etc.

Serial ID: X X X X X X X Y M D L N N N N

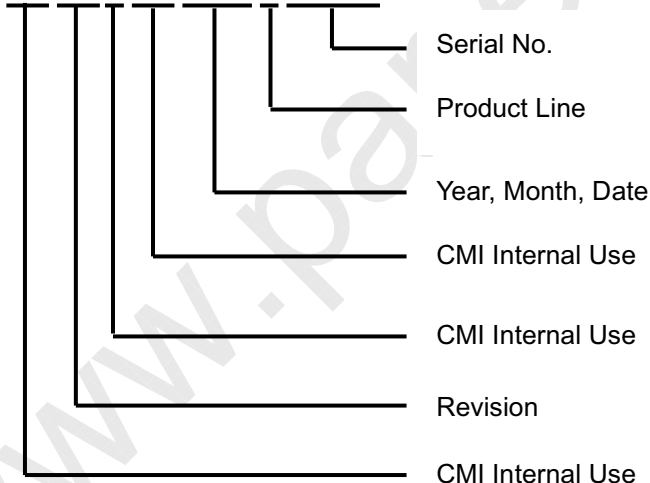

Serial ID includes the information as below:

Manufactured Date:

Year : 2001=1, 2002=2, 2003=3, 2004=4...2010=0, 2011=1, 2012=2...

Month: 1~9, A~C, for Jan. ~ Dec.

Day: 1~9, A~Y, for 1st to 31st, exclude I ,O, and U.

Revision Code : Cover all the change

Serial No. : Manufacturing sequence of product

Product Line : 1 → Line1, 2 → Line 2, ...etc.

10. PACKAGING

10.1 PACKAGING SPECIFICATIONS

- (1) 10 LCD modules / 1 Box
- (2) Box dimensions: 620(L) X 348 (W) X 430 (H) mm
- (3) Weight: 30kg (10 modules per box)

10.2 PACKAGING METHOD

Figures 10-1 and 10-2 are the packing method

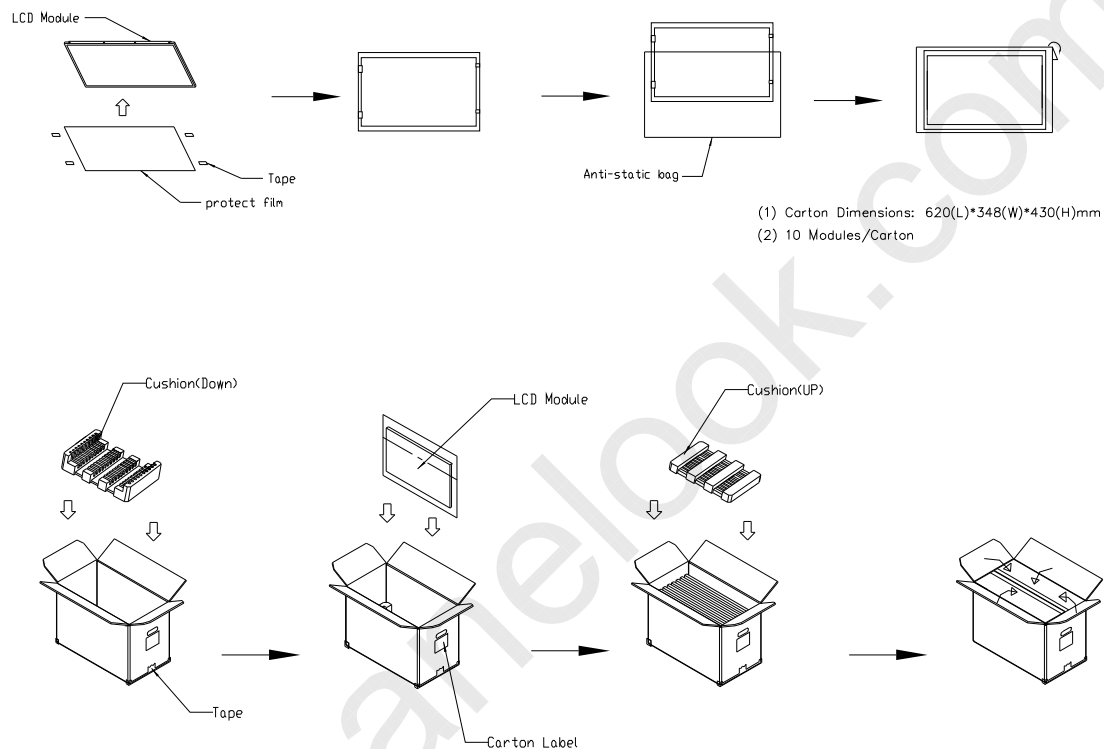
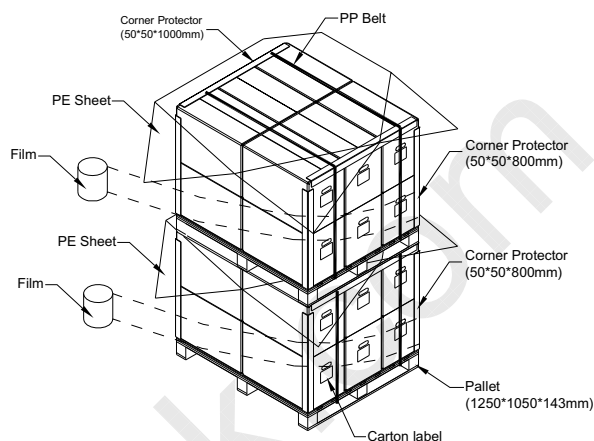
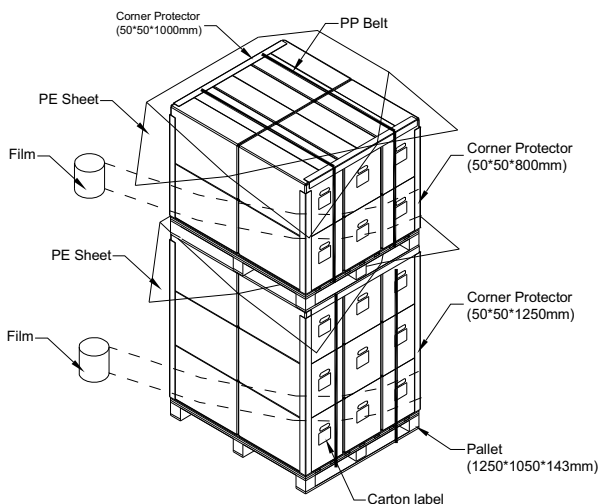

Figure 10-1 packing method

For ocean shipping

Sea / Land Transportation (40ft HQ Container)

Sea / Land Transportation (40ft Container)



For air transport

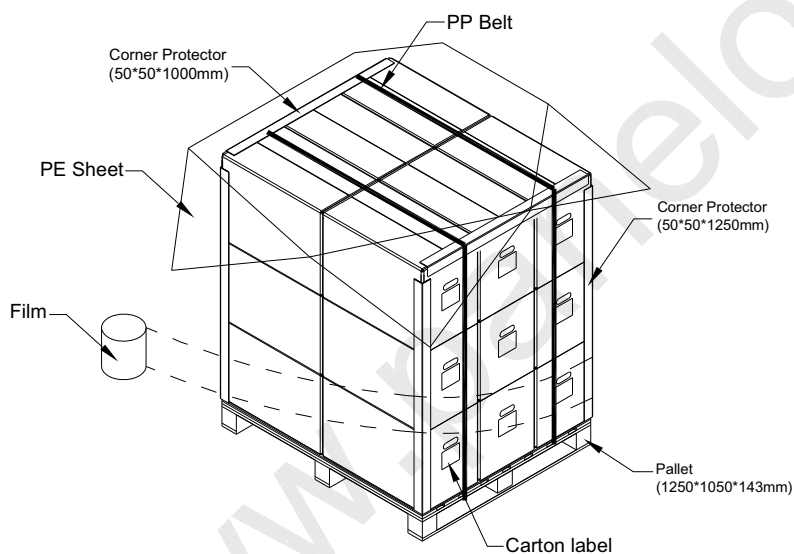
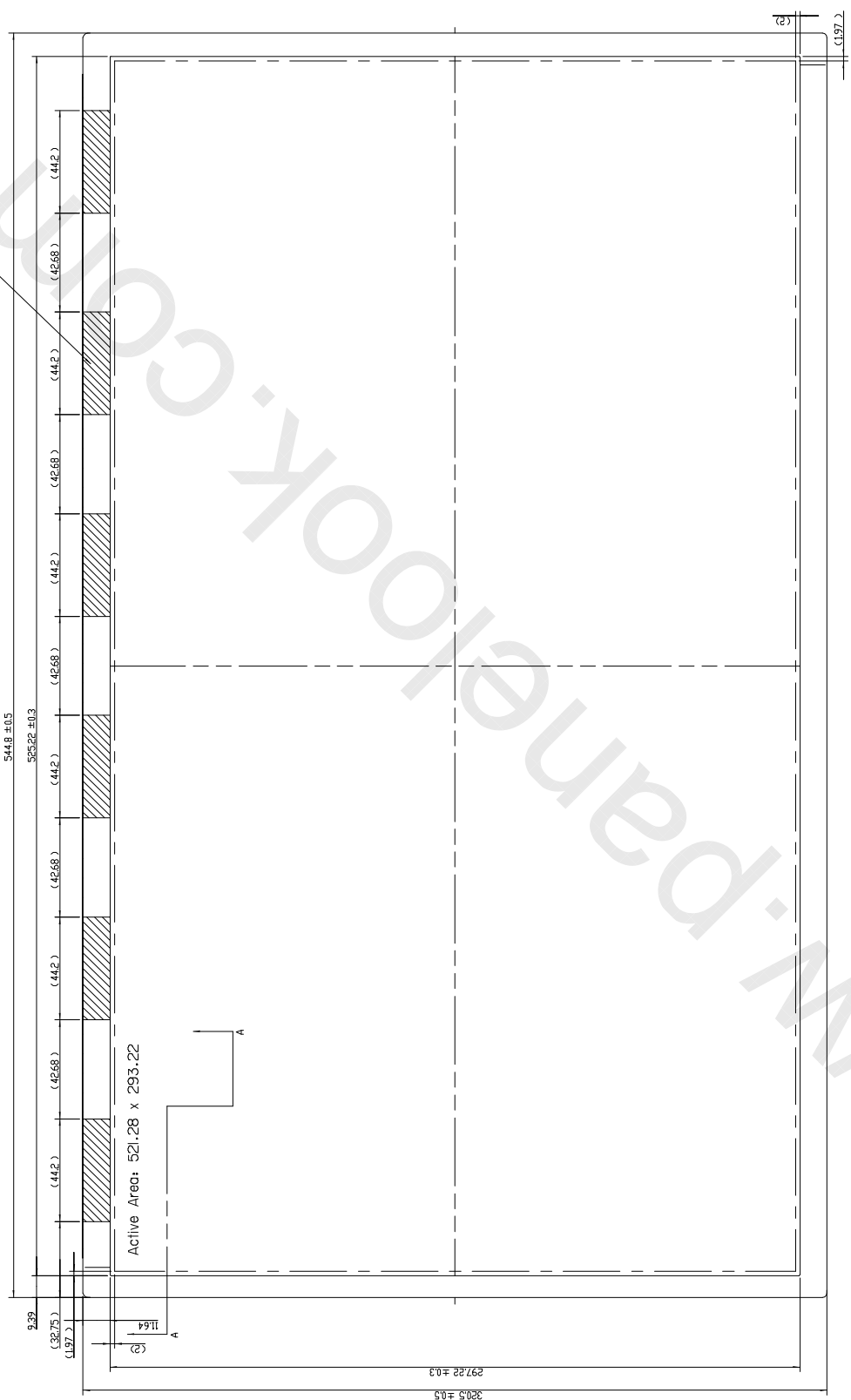

Figure 10-2 packing method

11. MECHANICAL CHARACTERISTIC

Data OFF Position
SI mechanical structure should not touch the positions of Data OFF

Data OFF Position
SI mechanical structure should not touch the positions of Data OFF



RETEL OPEN

NOTE:

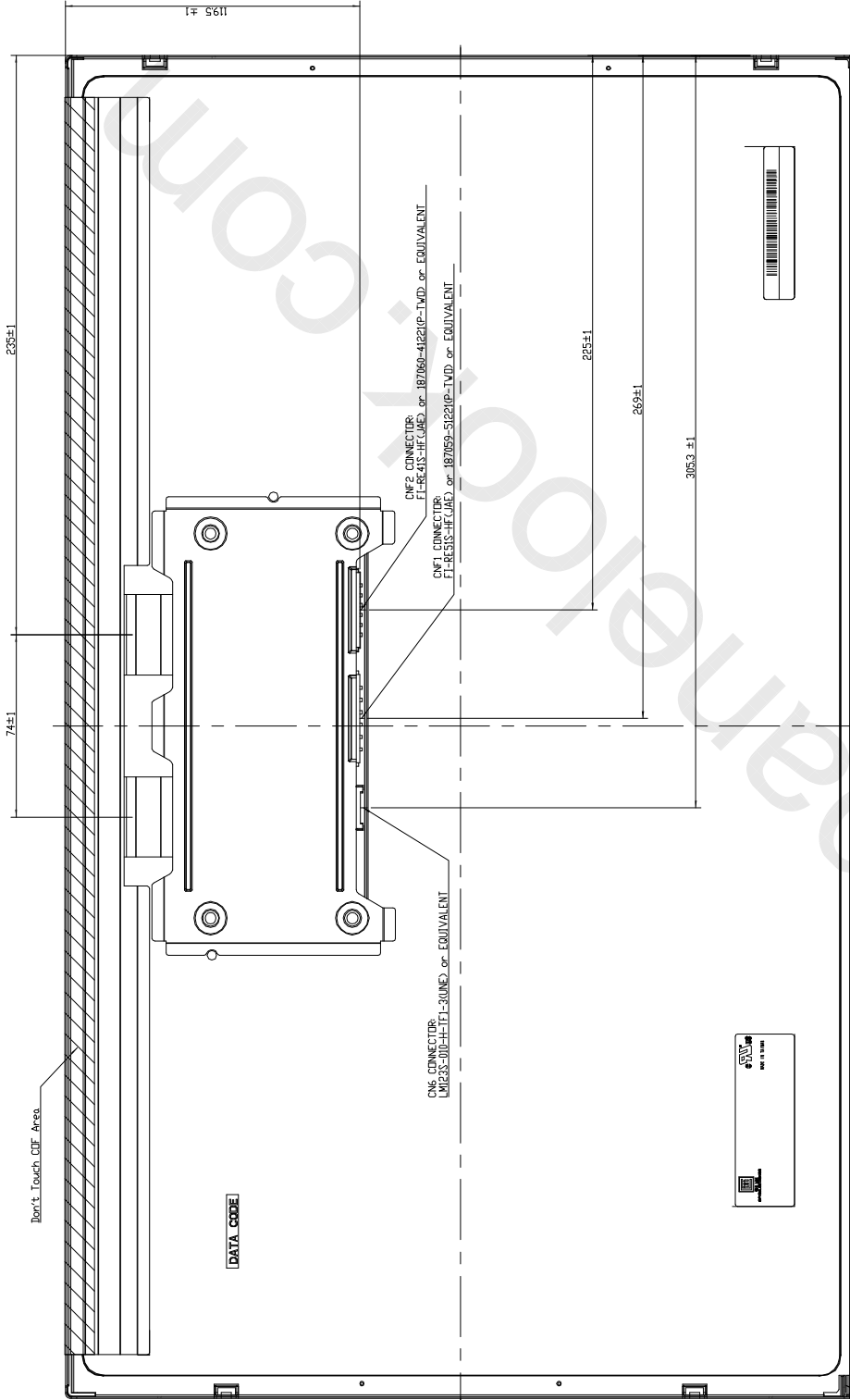

- NOTE:
1. DIMEN. BY AREA POSITION. TOLERANCE: $14-30 \mu\text{m}$ & $10-20 \mu\text{m}$
 2. UNDESIGNATED TOLERANCE: ± 0.5
 3. SIDE MOUNT HOLE ROTATIONAL TORQUE: MAX. IS 5 kgf-cm