

# TFT LCD Approval Specification

## MODEL NO.: V260B3 – P03

Customer: \_\_\_\_\_

Approved by: \_\_\_\_\_

Note:

Approved By	TV Head Division	
	LY Chen	

Reviewed By	QA Dept.	Product Development Div.
	Kc_Ko	WT Lin

Prepared By	LCD TV Marketing and Product Management Div.	
	WY Li	Delia Lin

**- CONTENTS -**

REVISION HISTORY	-----	3
1. GENERAL DESCRIPTION	-----	4
1.1 OVERVIEW		
1.2 CHARACTERISTICS		
1.3 MECHANICAL SPECIFICATIONS		
2. ABSOLUTE MAXIMUM RATINGS	-----	5
2.1 ABSOLUTE RATINGS OF ENVIRONMENT (BASED ON CMO MODULE V260B3-L03)		
2.2 ABSOLUTE RATINGS OF ENVIRONMENT (OPEN CELL)		
2.3 ELECTRICAL ABSOLUTE RATINGS (OPEN CELL)		
3. ELECTRICAL CHARACTERISTICS	-----	7
3.1 TFT LCD OPEN CELL		
4. BLOCK DIAGRAM	-----	9
4.1 TFT LCD MODULE		
5. INPUT TERMINAL PIN ASSIGNMENT	-----	10
5.1 TFT LCD MODULE		
5.2 LVDS INTERFACE		
5.3 COLOR DATA INPUT ASSIGNMENT		
6. INTERFACE TIMING	-----	13
6.1 INPUT SIGNAL TIMING SPECIFICATIONS		
6.2 POWER ON/OFF SEQUENCE		
7. OPTICAL CHARACTERISTICS	-----	16
7.1 TEST CONDITIONS		
7.2 OPTICAL SPECIFICATIONS		
8. DEFINITION OF LABELS	-----	20
8.1 OPEN CELL LABEL		
8.2 CARTON LABEL		
9. PACKAGING	-----	21
9.1 PACKING SPECIFICATIONS		
9.2 PACKING METHOD		
10. PRECAUTIONS	-----	23
10.1 ASSEMBLY AND HANDLING PRECAUTIONS		
10.2 SAFETY PRECAUTIONS		
11. REGULATORY STANDARD	-----	24
11.1 SAFETY		
12. MECHANICAL CHARACTERISTICS	-----	25

**REVISION HISTORY**

<b>Version</b>	<b>Date</b>	<b>Page (New)</b>	<b>Section</b>	<b>Description</b>
Ver 2.0	Jun. 5,'09	All	All	Approval Specification was first issued.

## 1. GENERAL DESCRIPTION

### 1.1 OVERVIEW

V260B3- P03 is a 26-inch TFT LCD cell with driver ICs and 1ch-LVDS interface. This module supports 1366 x 768 WXGA format and can display 16.7M colors ( 6-bit+Hi-FRC). The backlight unit is not built in

### 1.2 CHARACTERISTICS

CHARACTERISTICS ITEMS	SPECIFICATIONS
Screen Diagonal [in]	26.0
Pixels [lines]	1366 × 768
Active Area [mm]	575.769 × 323.712
Sub -Pixel Pitch [mm]	0.1405(H) × 0.4215(V)
Pixel Arrangement	RGB vertical stripe
Weight [g]	TYP. 850
Physical Size [mm]	592(W) x 339.8(H) x 1.84(D) Typ.
Display Mode	MVA, Normally Black
Contrast Ratio	(3000:1) Typ. (Typical value measured at CMO's module)
Glass thickness (Array/CF) [mm]	0.7 / 0.7
Viewing Angle (CR>20)	+88/-88(H), +88/-88(V) Typ. (Typical value measured at CMO's module)
Color Chromaticity	R=0.649, 0.326 G=0.271, 0.582 B=0.136, 0.101 W=0.299, 0.320 *Please refer to "color chromaticity" on p.16
Cell Transparency [%]	5.0%Typ. (Typical value measured at CMO's module)
Polarizer (CF side)	Anti-Glare coating 587.4(H) x 335.2(w). Hardness: 3H
Polarizer (TFT side)	587.4(H) x 335.2(w).

### 1.3 MECHANICAL SPECIFICATIONS

Item	Min.	Typ.	Max.	Unit	Note
Weight		850		g	
I/F connector mounting position	The mounting inclination of the connector makes the screen center within ±0.5mm as the horizontal.				(1)

Note (1) Connector mounting position



## 2. ABSOLUTE MAXIMUM RATINGS

### 2.1 ABSOLUTE RATINGS OF ENVIRONMENT (BASED ON CMO MODULE V260B3-L03)

Item	Symbol	Value		Unit	Note
		Min.	Max.		
Storage Temperature	T <sub>ST</sub>	-20	+60	°C	(1)
Operating Ambient Temperature	T <sub>OP</sub>	0	+50	°C	(1), (2)
Shock (Non-Operating)	S <sub>NOF</sub>	—	50	G	(3), (5)
Vibration (Non-Operating)	V <sub>NOF</sub>	—	1.0	G	(4), (5)

Note (1) Temperature and relative humidity range is shown in the figure below.

(a) 90 %RH Max. ( $T_a \leq 40$  °C).

(b) Wet-bulb temperature should be 39 °C Max. ( $T_a > 40$  °C).

(c) No condensation.

Note (2) The maximum operating temperature is based on the test condition that the surface temperature of display area is less than or equal to 65 °C with LCD module alone in a temperature controlled chamber. Thermal management should be considered in final product design to prevent the surface temperature of display area from being over 65 °C. The range of operating temperature may degrade in case of improper thermal management in final product design.

Note (3) 11 ms, half sine wave, 1 time for  $\pm X$ ,  $\pm Y$ ,  $\pm Z$ .

Note (4) 10 ~ 500 Hz, 10 min, 1 time each X, Y, Z.

Note (5) At testing Vibration and Shock, the fixture in holding the module has to be hard and rigid enough so that the module would not be twisted or bent by the fixture.

#### Relative Humidity (%RH)

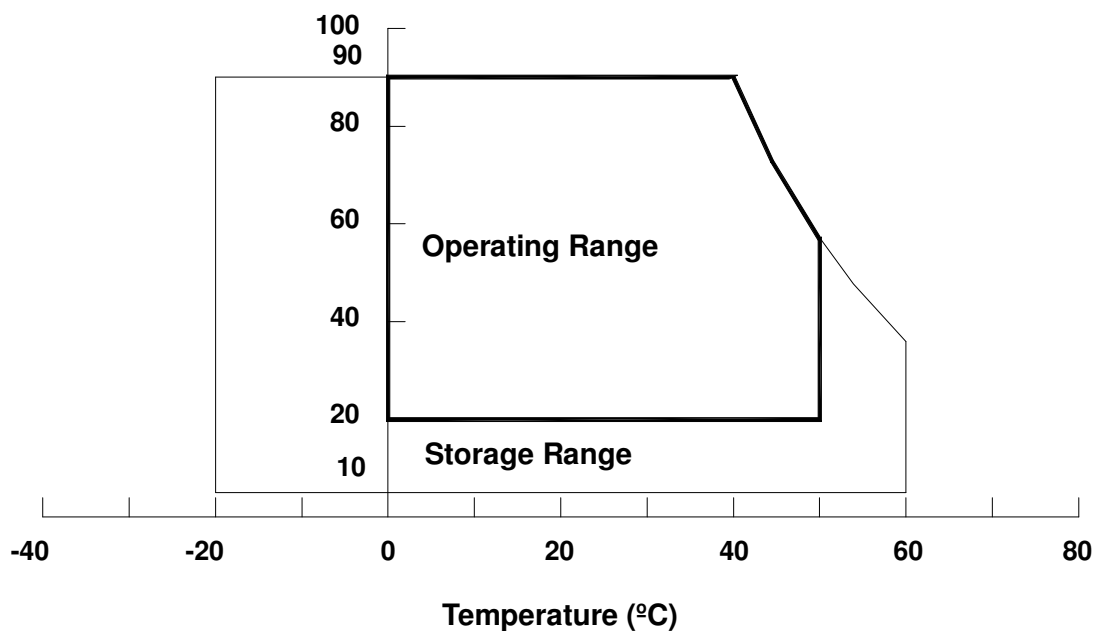

## 2.2 ABSOLUTE RATINGS OF ENVIRONMENT (OPEN CELL)

Storage Condition : With shipping package.

Storage temperature range :  $25 \pm 5$  °C

Storage humidity range :  $50 \pm 10\%$  RH

Shelf life : a month

## 2.3 ELECTRICAL ABSOLUTE RATINGS

### 2.3.1 ELECTRICAL ABSOLUTE RATINGS (OPEN CELL)

Item	Symbol	Value		Unit	Note
		Min.	Max.		
Power Supply Voltage	V <sub>CC</sub>	-0.3	13.0	V	(1)
Input Signal Voltage	V <sub>IN</sub>	-0.3	3.6	V	

Note (1) Permanent damage to the device may occur if maximum values are exceeded. Function operation should be restricted to the conditions described under Normal Operating Conditions.

### 3. ELECTRICAL CHARACTERISTICS

#### 3.1 TFT LCD MODULE

 $T_a = 25 \pm 2 \text{ }^\circ\text{C}$ 

Parameter		Symbol	Value			Unit	Note
			Min.	Typ.	Max.		
Power Supply Voltage		$V_{CC}$	10.8	12.0	13.2	V	(1)
Power Supply Ripple Voltage		$V_{RP}$	—	—	300	mV	
Rush Current		$I_{RUSH}$	—	—	3.0	A	(2)
Power Supply Current	White	$I_{CC}$	—	0.40	0.50	A	(3)
	Black		—	0.30	0.35	A	
	Vertical Stripe		—	0.40	0.50	A	
LVDS Interface	Differential Input High Threshold Voltage	$V_{LVTH}$	+100	—	—	mV	
	Differential Input Low Threshold Voltage	$V_{LVTL}$	—	—	-100	mV	
	Common Input Voltage	$V_{LVC}$	1.125	1.25	1.375	V	
	Terminating Resistor	$R_T$	—	100	—	ohm	
CMOS interface	Input High Threshold Voltage	$V_{IH}$	2.7	—	3.3	V	
	Input Low Threshold Voltage	$V_{IL}$	0	—	0.7	V	

Note (1) The module should be always operated within above ranges.

Note (2) Measurement Conditions:

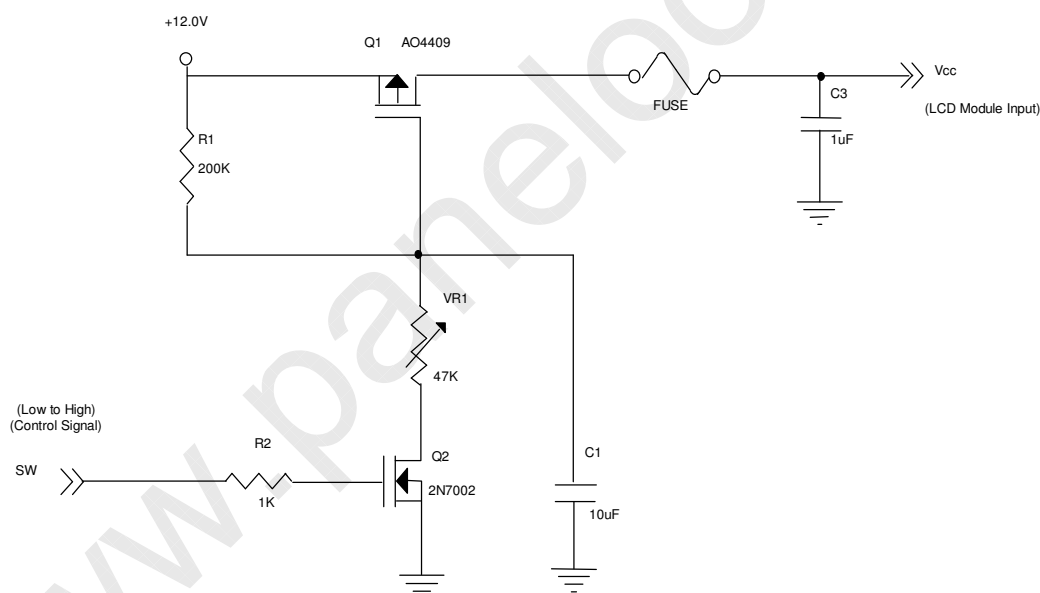

**Vcc rising time is 470us**

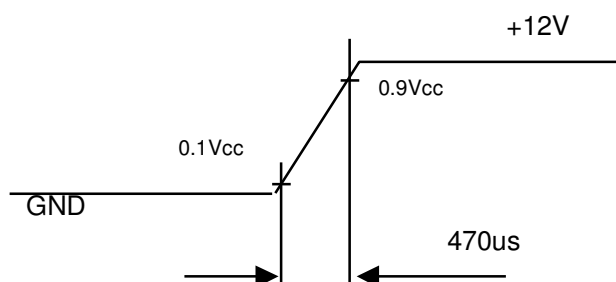

Note (3) The specified power supply current is under the conditions at  $V_{cc} = 12\text{ V}$ ,  $T_a = 25 \pm 2\text{ }^\circ\text{C}$ ,  $f_v = 60\text{ Hz}$ , whereas a power dissipation check pattern below is displayed.

a. White Pattern

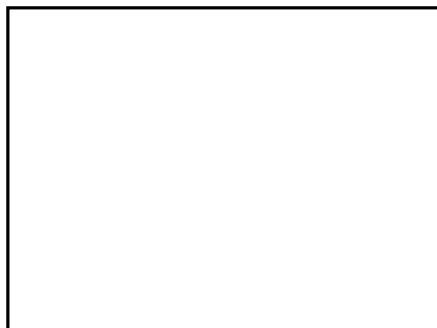

Active Area

b. Black Pattern



Active Area

c. Vertical Stripe Pattern

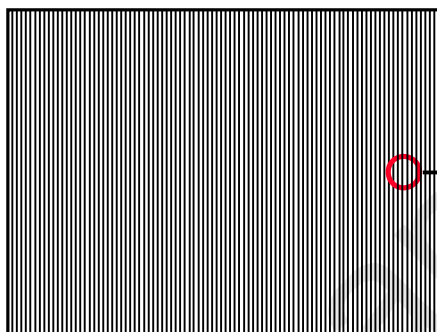

Active Area

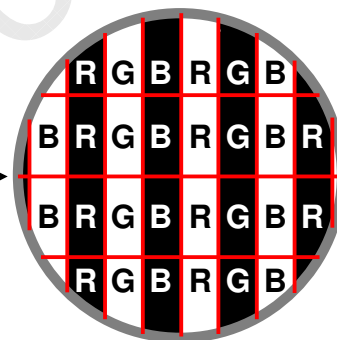



#### 4. BLOCK DIAGRAM

##### 4.1 TFT LCD MODULE

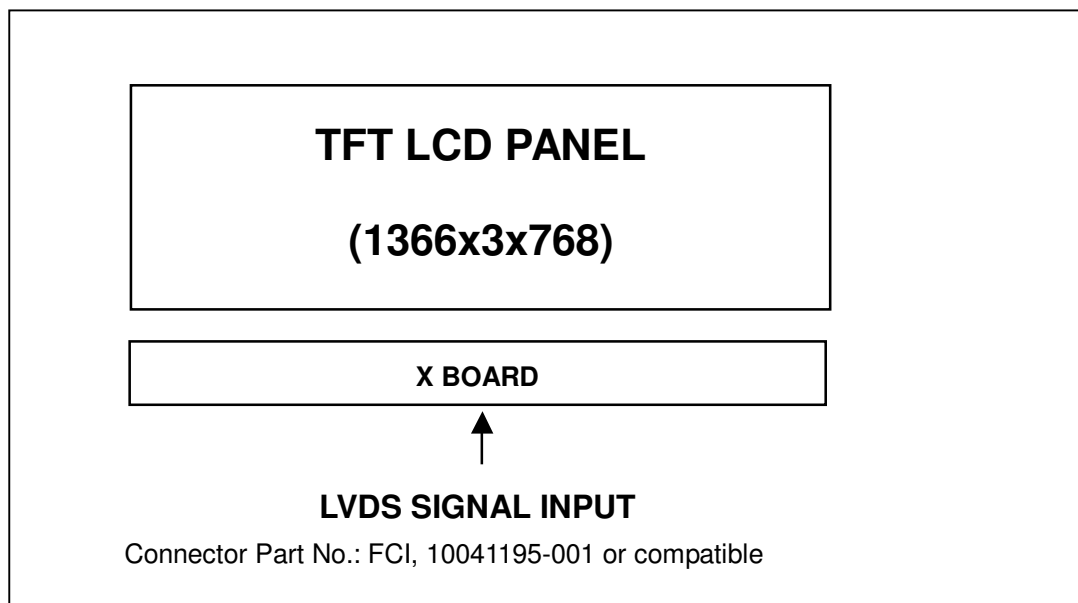

## 5. INPUT TERMINAL PIN ASSIGNMENT

### 5.1 TFT LCD MODULE

#### CN1 Connector Pin Assignment

Pin No.	Symbol	Description	Note
1	NC	No connection	(2)
2	NC	No connection	(2)
3	NC	No connection	(2)
4	GND	Ground	
5	RX0-	Negative transmission data of pixel 0	
6	RX0+	Positive transmission data of pixel 0	
7	GND	Ground	
8	RX1-	Negative transmission data of pixel 1	
9	RX1+	Positive transmission data of pixel 1	
10	GND	Ground	
11	RX2-	Negative transmission data of pixel 2	
12	RX2+	Positive transmission data of pixel 2	
13	GND	Ground	
14	RXCLK-	Negative of clock	
15	RXCLK+	Positive of clock	
16	GND	Ground	
17	RX3-	Negative transmission data of pixel 3	
18	RX3+	Positive transmission data of pixel 3	
19	GND	Ground	
20	NC	No connection	(2)
21	SELLVDS	Select LVDS data format	(3)
22	NC	No connection	(2)
23	GND	Ground	
24	GND	Ground	
25	GND	Ground	
26	VCC	Power supply: +12V	
27	VCC	Power supply: +12V	
28	VCC	Power supply: +12V	
29	VCC	Power supply: +12V	
30	VCC	Power supply: +12V	

Note (1) Connector Part No.: FCI, 10041195-001 or compatible

Note (2) Reserved for internal use. Please leave it open.

Note (3) High or OPEN: Normal, Ground: JEIDA LVDS format

Please refer to 5.2 LVDS INTERFACE (Page 11)

## 5.2 LVDS INTERFACE

### SELLVDS = H or Open (VESA)

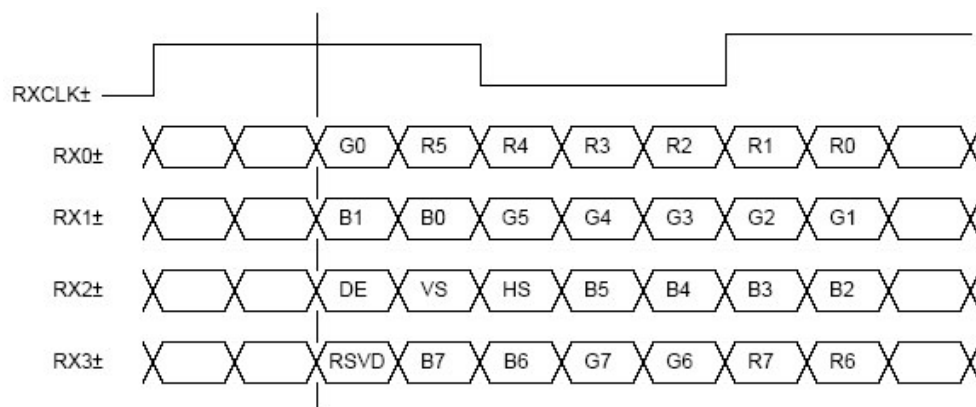

### SELLVDS = L (JEIDA)

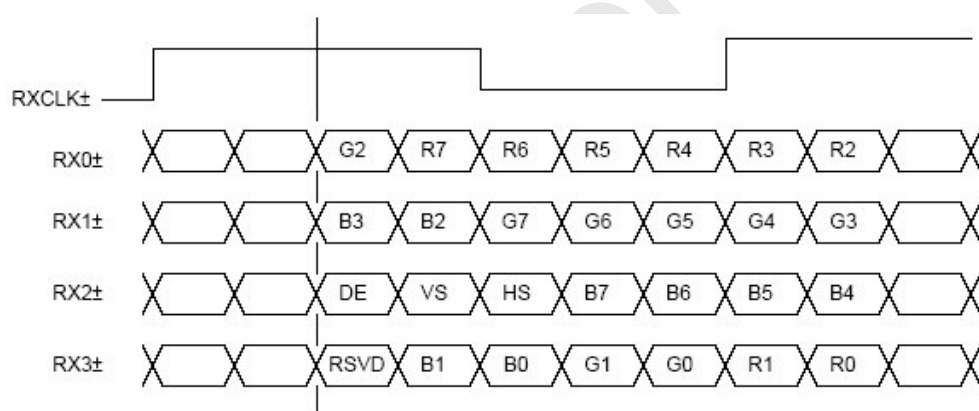

R0~R7: Pixel R Data (7; MSB, 0; LSB)

G0~G7: Pixel G Data (7; MSB, 0; LSB)

B0~B7: Pixel B Data (7; MSB, 0; LSB)

DE : Data enable signal

Notes(1) RSVD(reserved)pins on the transmitter shall be "H" or "L".



### 5.3 COLOR DATA INPUT ASSIGNMENT

The brightness of each primary color (red, green and blue) is based on the 8-bit gray scale data input for the color. The higher the binary input, the brighter the color. The table below provides the assignment of color versus data input.

Color		Data Signal																						
		Red								Green								Blue						
		R7	R6	R5	R4	R3	R2	R1	R0	G7	G6	G5	G4	G3	G2	G1	G0	B7	B6	B5	B4	B3	B2	B1
Basic Colors	Black	0	0	0	0	0	0	0	0	0	0	0	0	0	0	0	0	0	0	0	0	0	0	0
	Red	1	1	1	1	1	1	1	1	0	0	0	0	0	0	0	0	0	0	0	0	0	0	0
	Green	0	0	0	0	0	0	0	0	1	1	1	1	1	1	1	0	0	0	0	0	0	0	0
	Blue	0	0	0	0	0	0	0	0	0	0	0	0	0	0	0	1	1	1	1	1	1	1	1
	Cyan	0	0	0	0	0	0	0	0	1	1	1	1	1	1	1	1	1	1	1	1	1	1	1
	Magenta	1	1	1	1	1	1	1	1	0	0	0	0	0	0	0	0	1	1	1	1	1	1	1
	Yellow	1	1	1	1	1	1	1	1	1	1	1	1	1	1	1	0	0	0	0	0	0	0	0
	White	1	1	1	1	1	1	1	1	1	1	1	1	1	1	1	1	1	1	1	1	1	1	1
Gray Scale Of Red	Red(0) / Dark	0	0	0	0	0	0	0	0	0	0	0	0	0	0	0	0	0	0	0	0	0	0	
	Red(1)	0	0	0	0	0	0	0	1	0	0	0	0	0	0	0	0	0	0	0	0	0	0	
	Red(2)	0	0	0	0	0	0	1	0	0	0	0	0	0	0	0	0	0	0	0	0	0	0	
	:	:	:	:	:	:	:	:	:	:	:	:	:	:	:	:	:	:	:	:	:	:	:	
	:	:	:	:	:	:	:	:	:	:	:	:	:	:	:	:	:	:	:	:	:	:	:	
	Red(253)	1	1	1	1	1	1	0	1	0	0	0	0	0	0	0	0	0	0	0	0	0	0	
	Red(254)	1	1	1	1	1	1	1	0	0	0	0	0	0	0	0	0	0	0	0	0	0	0	
	Red(255)	1	1	1	1	1	1	1	1	0	0	0	0	0	0	0	0	0	0	0	0	0	0	
Gray Scale Of Green	Green(0) / Dark	0	0	0	0	0	0	0	0	0	0	0	0	0	0	0	0	0	0	0	0	0	0	
	Green(1)	0	0	0	0	0	0	0	0	0	0	0	0	0	0	1	0	0	0	0	0	0	0	
	Green(2)	0	0	0	0	0	0	0	0	0	0	0	0	0	1	0	0	0	0	0	0	0	0	
	:	:	:	:	:	:	:	:	:	:	:	:	:	:	:	:	:	:	:	:	:	:	:	
	:	:	:	:	:	:	:	:	:	:	:	:	:	:	:	:	:	:	:	:	:	:	:	
	Green(253)	0	0	0	0	0	0	0	0	1	1	1	1	1	1	0	1	0	0	0	0	0	0	
	Green(254)	0	0	0	0	0	0	0	0	1	1	1	1	1	1	1	0	0	0	0	0	0	0	
	Green(255)	0	0	0	0	0	0	0	0	1	1	1	1	1	1	1	1	0	0	0	0	0	0	
Gray Scale Of Blue	Blue(0) / Dark	0	0	0	0	0	0	0	0	0	0	0	0	0	0	0	0	0	0	0	0	0	0	
	Blue(1)	0	0	0	0	0	0	0	0	0	0	0	0	0	0	0	0	0	0	0	0	0	1	
	Blue(2)	0	0	0	0	0	0	0	0	0	0	0	0	0	0	0	0	0	0	0	0	0	1	
	:	:	:	:	:	:	:	:	:	:	:	:	:	:	:	:	:	:	:	:	:	:	:	
	:	:	:	:	:	:	:	:	:	:	:	:	:	:	:	:	:	:	:	:	:	:	:	
	Blue(253)	0	0	0	0	0	0	0	0	0	0	0	0	0	0	0	1	1	1	1	1	1	0	
	Blue(254)	0	0	0	0	0	0	0	0	0	0	0	0	0	0	0	1	1	1	1	1	1	0	
	Blue(255)	0	0	0	0	0	0	0	0	0	0	0	0	0	0	0	1	1	1	1	1	1	1	

Note (1) 0: Low Level Voltage, 1: High Level Voltage

## 6. INTERFACE TIMING

### 6.1 INPUT SIGNAL TIMING SPECIFICATIONS

The input signal timing specifications are shown as the following table and timing diagram.

Signal	Item	Symbol	Min.	Typ.	Max.	Unit	Note
LVDS Receiver Clock	Frequency	1/Tc	60	76	82	MHz	
	Input cycle to cycle jitter	Trcl	—	—	200	ps	
LVDS Receiver Data	Setup Time	Tlvsu	600	—	—	ps	
	Hold Time	Tlvhd	600	—	—	ps	
Vertical Active Display Term	Frame Rate	Fr5	47	50	53	Hz	
		Fr6	57	60	63	Hz	
	Total	Tv	778	806	888	Th	Tv=Tvd+Tvb
	Display	Tvd	768	768	768	Th	-
	Blank	Tvb	10	38	120	Th	-
Horizontal Active Display Term	Total	Th	1442	1560	1936	Tc	Th=Thd+Thb
	Display	Thd	1366	1366	1366	Tc	-
	Blank	Thb	76	194	570	Tc	-

Note (1) Since this module is operated in DE only mode, Hsync and Vsync input signals should be set to low logic level. Otherwise, this module would operate abnormally.

### INPUT SIGNAL TIMING DIAGRAM

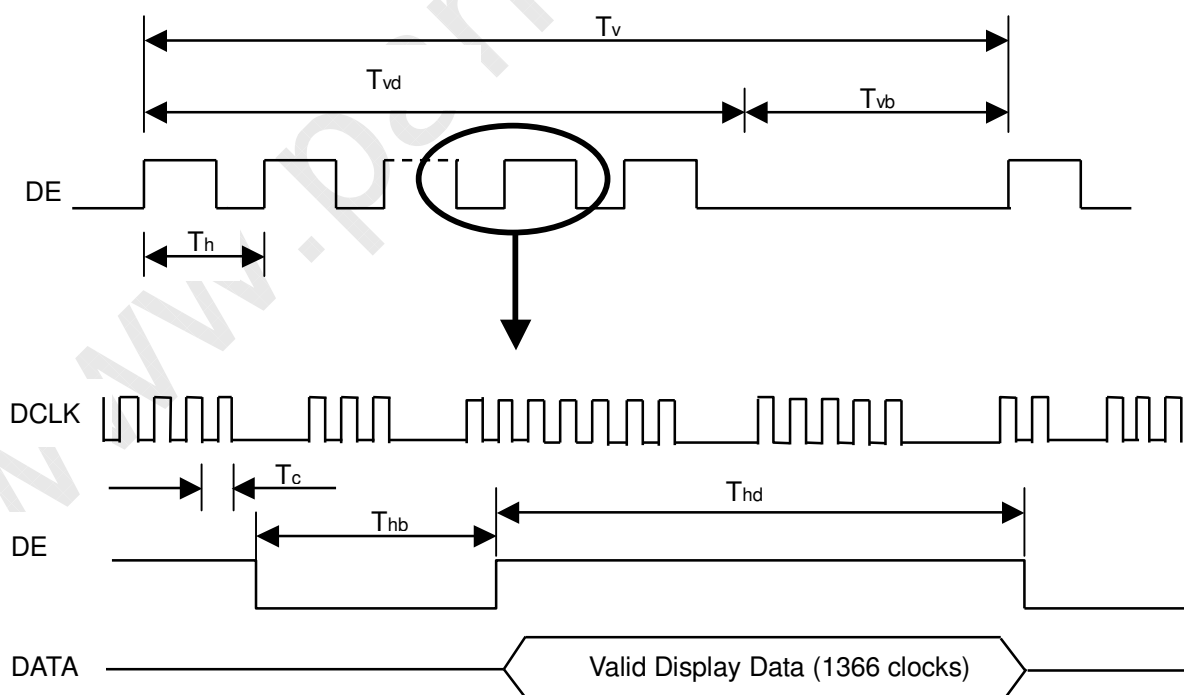

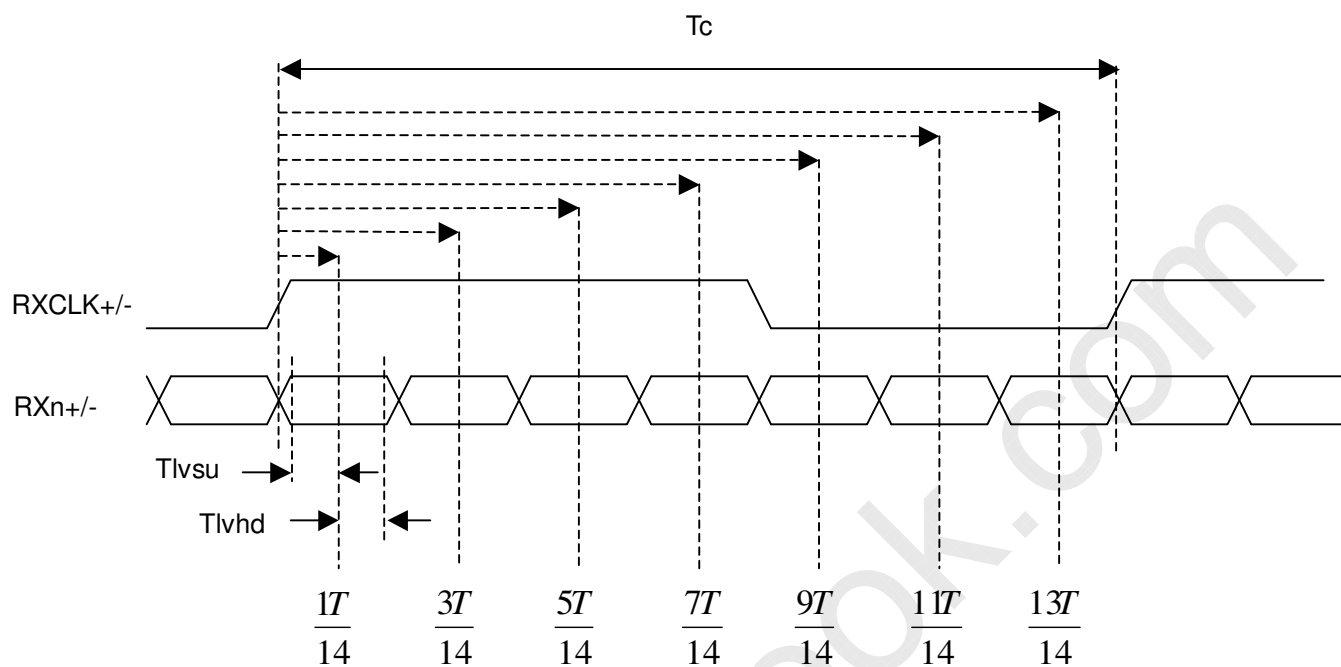
**LVDS RECEIVER INTERFACE TIMING DIAGRAM**

## 6.2 POWER ON/OFF SEQUENCE

To prevent a latch-up or DC operation of LCD module, the power on/off sequence should be as the diagram below.

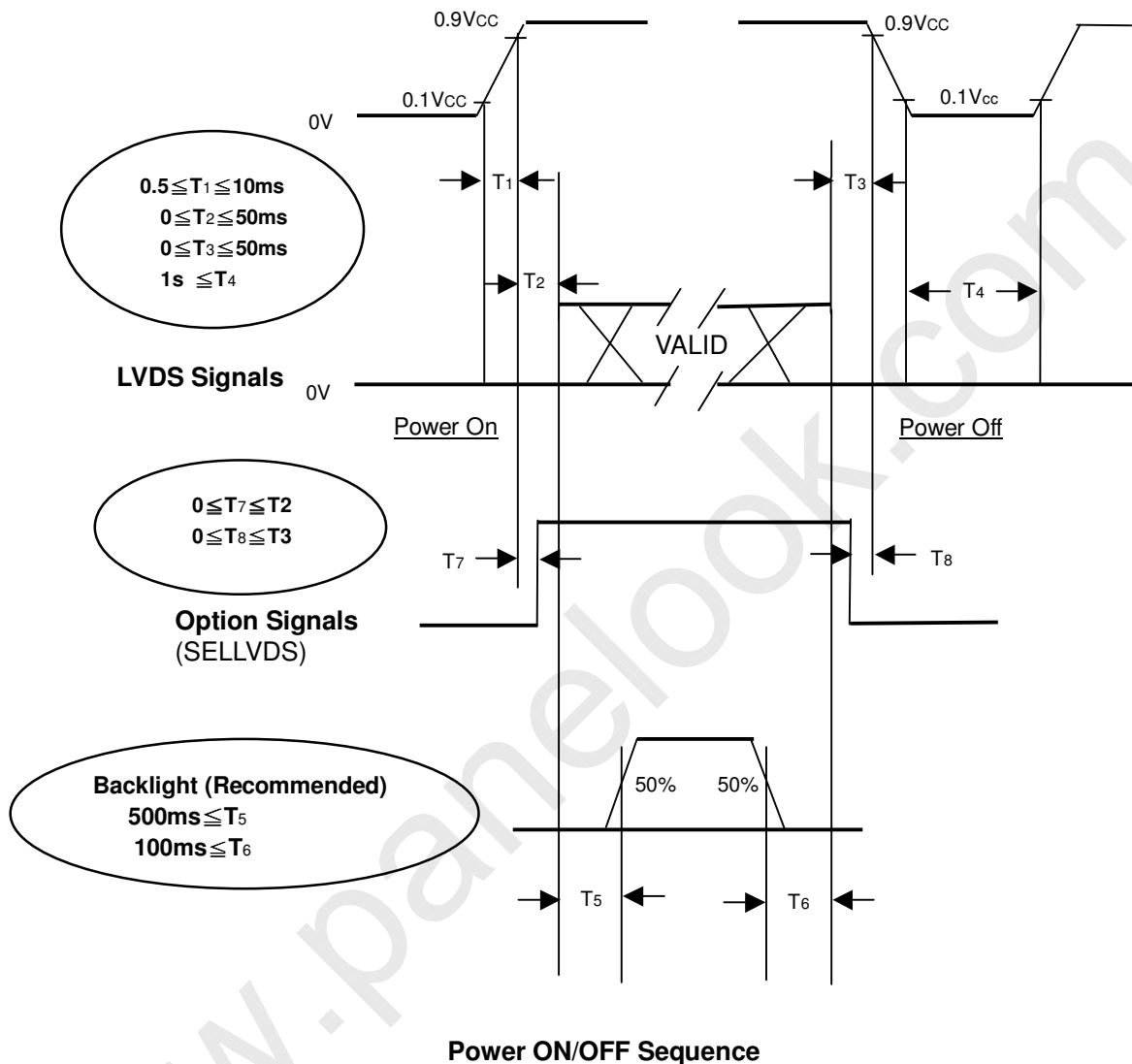

Note (1) The supply voltage of the external system for the module input should follow the definition of Vcc.

Note (2) Apply the lamp voltage within the LCD operation range. When the backlight turns on before the LCD operation or the LCD turns off before the backlight turns off, the display may momentarily become abnormal screen.

Note (3) In case of Vcc is in off level, please keep the level of input signals on the low or high impedance. If  $T_2 < 0$ , that maybe cause electrical overstress failure.

Note (4) T4 should be measured after the module has been fully discharged between power off and on period.

Note (5) Interface signal shall not be kept at high impedance when the power is on.

## 7. OPTICAL CHARACTERISTICS

### 7.1 TEST CONDITIONS

Item	Symbol	Value	Unit
Ambient Temperature	Ta	25±2	°C
Ambient Humidity	Ha	50±10	%RH
Supply Voltage	V <sub>CC</sub>	12.0	V
Input Signal	According to typical value in "3. ELECTRICAL CHARACTERISTICS"		
Lamp Current	I <sub>L</sub>	9.0 ± 0.5	mA
Oscillating Frequency (Inverter)	F <sub>w</sub>	58 ± 3	KHz
Vertical Frame Rate	Fr	60	Hz

### 7.2 OPTICAL SPECIFICATIONS

The relative measurement methods of optical characteristics are shown as below. The following items should be measured under the test conditions described in 7.1 and stable environment shown in Note (5).

Item		Symbol	Condition	Min.	Typ.	Max.	Unit	Note
Color Chromaticity	Red	Rcx	Viewing Angle at Normal Direction Standard light source "C"	-	0.649	-	-	(0),(5)
		Rcy			0.326		-	
	Green	Gcx			0.271		-	
		Gcy			0.582		-	
	Blue	Bcx			0.136		-	
		Bcy			0.101		-	
	White	Wcx			0.299		-	
		Wcy			0.320		-	
Center Transmittance		T%	$\theta_x=0^\circ, \theta_y=0^\circ$	-	5.0	-	%	(1),(7)
Contrast Ratio		CR	with CMO module	-	3000	-	-	(1),(3)
Response Time		Gray to gray	$\theta_x=0^\circ, \theta_y=0^\circ$ with CMO Module@60Hz	-	8.5	-	ms	(4)
White Variation		$\delta W$	$\theta_x=0^\circ, \theta_y=0^\circ$ with CMO module	-	-	1.3	-	(1),(6)
Viewing Angle	Horizontal	$\theta_{x+}$	CR≥20 With CMO module	-	88	-	Deg.	(1),(2)
		$\theta_{x-}$			88			
	Vertical	$\theta_{y+}$			88			
		$\theta_{y-}$			88			



Note (0) Light source is the standard light source "C" which is defined by CIE and driving voltage are based on suitable gamma voltages. The calculating method is as following :

1. Measure Module's and BLU's spectrum. White is without signal input and R,G,B are with signal input. BLU(for V260B2-L03) is supplied by CMO.
2. Calculate cell's spectrum.
3. Calculate cell's chromaticity by using the spectrum of standard light source "C".

Note (1) Light source is the BLU which is supplied by CMO and driving voltage are based on suitable gamma voltages.

Note (2) Definition of Viewing Angle ( $\theta_x, \theta_y$ ):

Viewing angles are measured by EZ-Contrast 160R (Eldim)

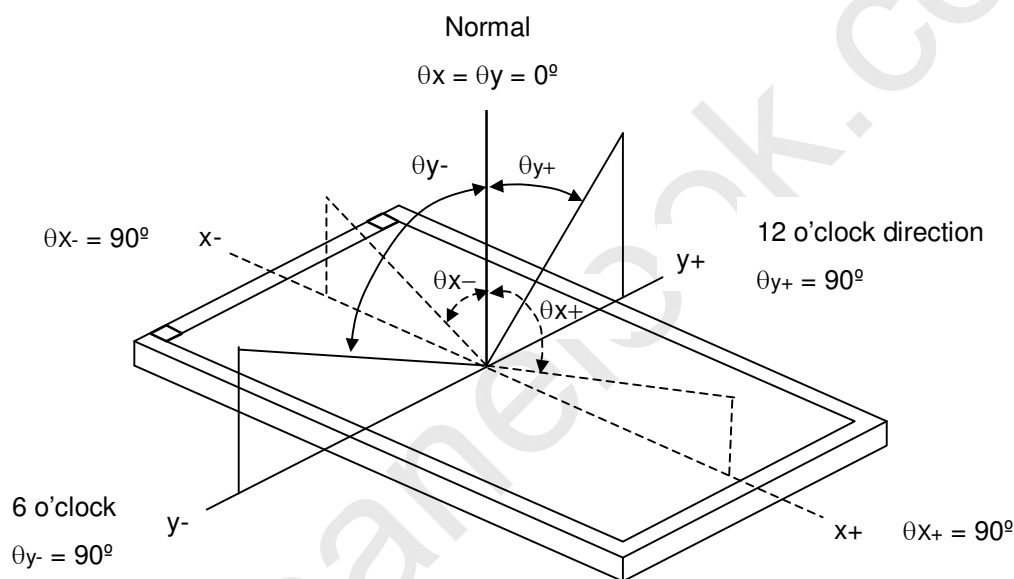

Note (3) Definition of Contrast Ratio (CR):

The contrast ratio can be calculated by the following expression.

$$\text{Contrast Ratio (CR)} = L_{255} / L_0$$

L255: Luminance of gray level 255

L 0: Luminance of gray level 0

CR = CR (5), where CR (X) is corresponding to the Contrast Ratio of the point X at the figure in

Note (6).

Note (4) Definition of Response Time ( $T_R$ ,  $T_F$ ):

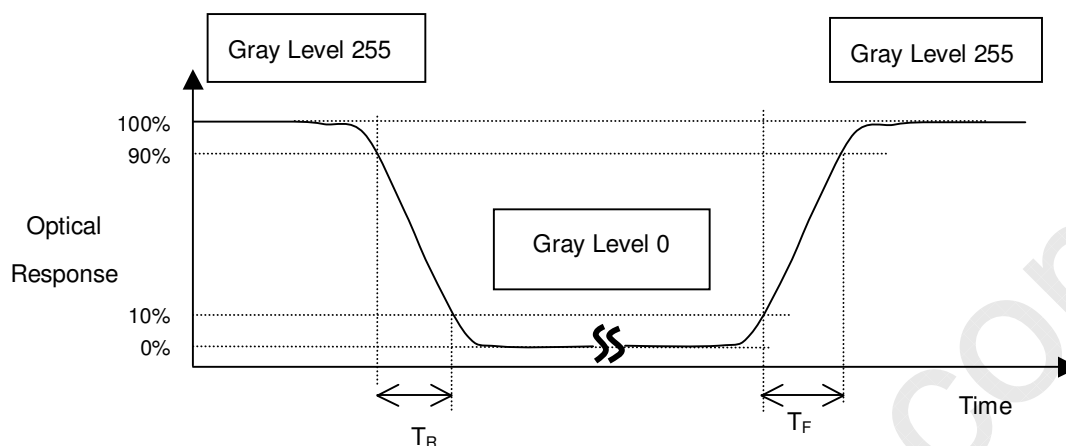

Note (5) Measurement Setup:

The LCD module should be stabilized at given temperature for 1 hour to avoid abrupt temperature change during measuring. In order to stabilize the luminance, the measurement should be executed after lighting Backlight for 1 hour in a windless room.

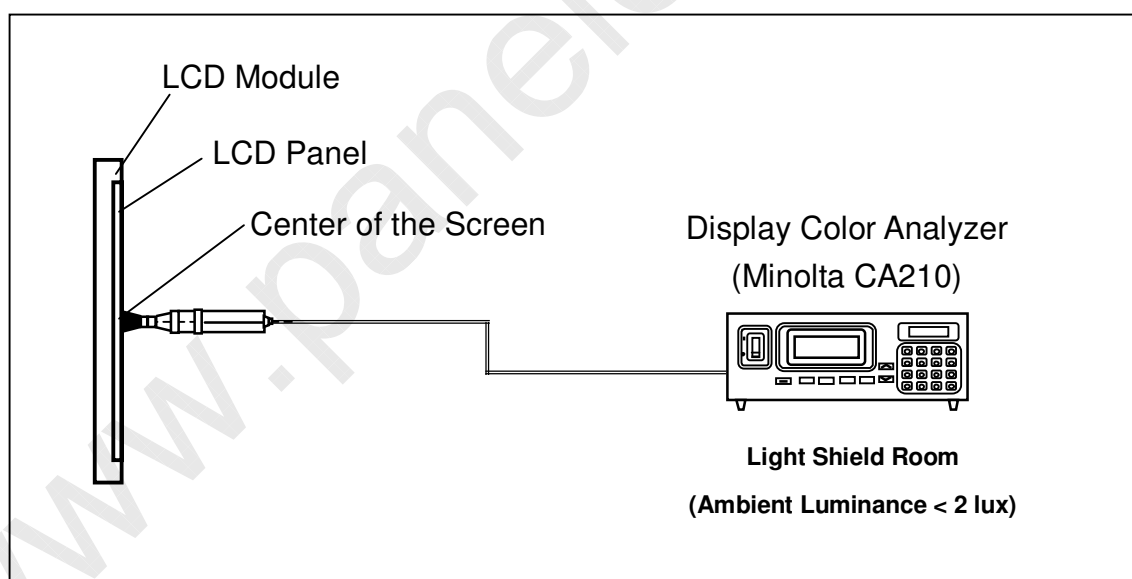

Note (6) Definition of White Variation ( $\delta W$ ):

Measure the luminance of gray level 255 at 5 points

$$\delta W = \text{Maximum [L (1), L (2), L (3), L (4), L (5)]} / \text{Minimum [L (1), L (2), L (3), L (4), L (5)]}$$

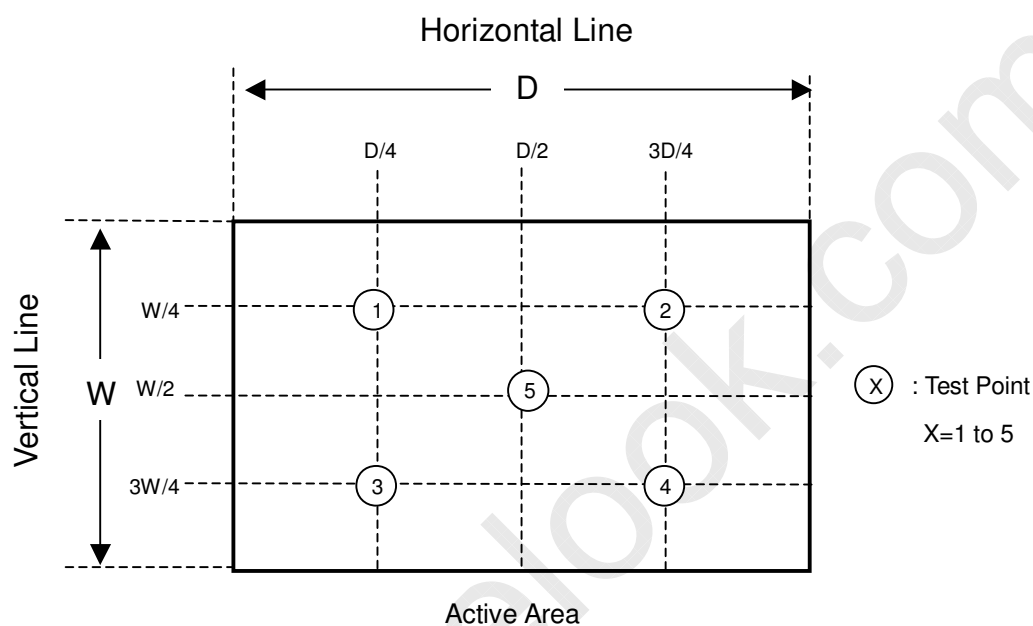

Note (7) Definition of Transmittance (T%) :

Module is without signal input.

$$\text{Transmittance} = \frac{\text{Luminance of LCD module}}{\text{Luminance of backlight}} * 100\%$$

## 8. DEFINITION OF LABELS

### 8.1 OPEN CELL LABEL

The barcode nameplate is pasted on each open cell as illustration for CMO internal control.



### 8.2 CARTON LABEL

The barcode nameplate is pasted on each box as illustration, and its definitions are as following explanation

P.O. NO. \_\_\_\_\_

Parts ID. \_\_\_\_\_

Carton ID.  Quantities   21  

XXXXXXXXXXXXXXXXXX

Made in Taiwan

P.O. NO. \_\_\_\_\_

Parts ID. \_\_\_\_\_

Carton ID.  Quantities   21  

XXXXXXXXXXXXXXXXXX

Made in China

- (a) Model Name: V260B3- P03
- (b) Carton ID: CMO internal control
- (c) Quantities: 21

## 9. PACKAGING

### 9.1 PACKING SPECIFICATIONS

- (1) 21PCS LCD TV Panels / 1 Box
- (2) Box dimensions : 812 (L) X 572 (W) X 277 (H)
- (3) Weight : approximately 27.5 Kg

### 9.2 PACKING METHOD

Figures 9-1 and 9-2 are the packing method

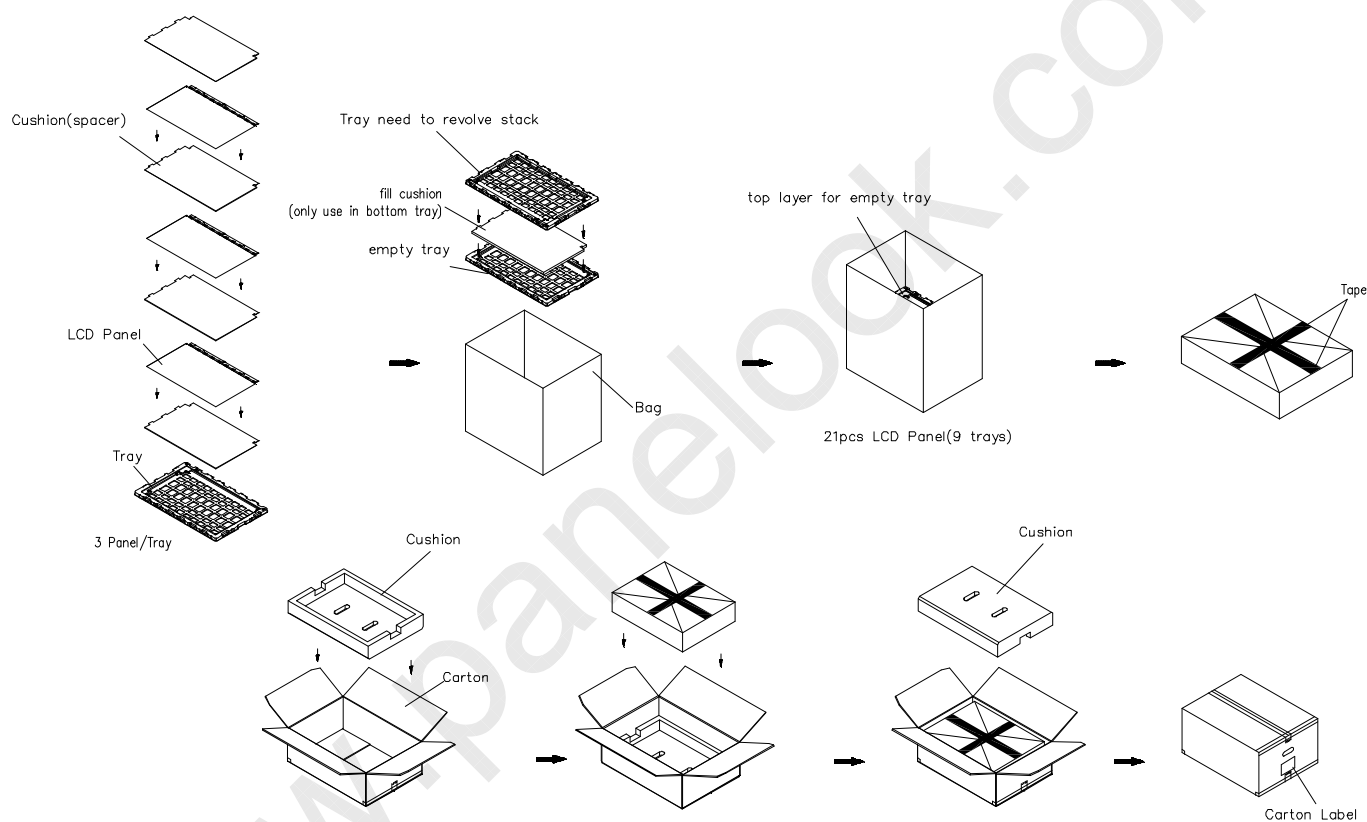
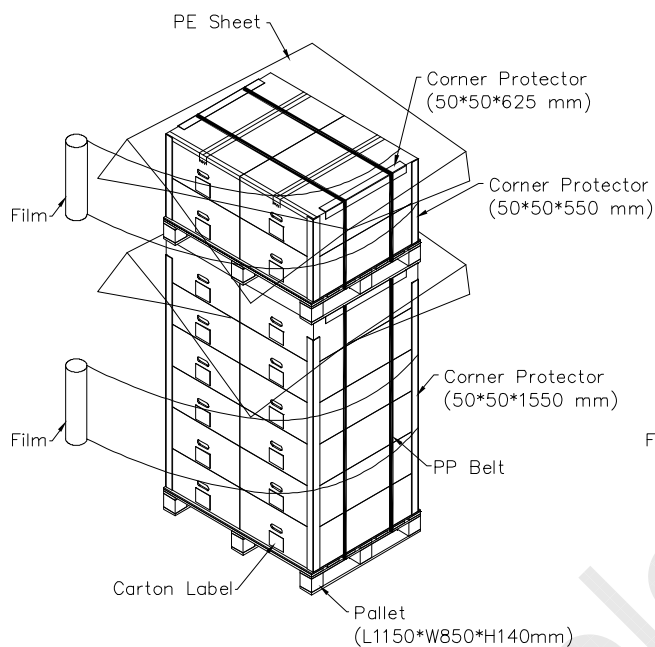
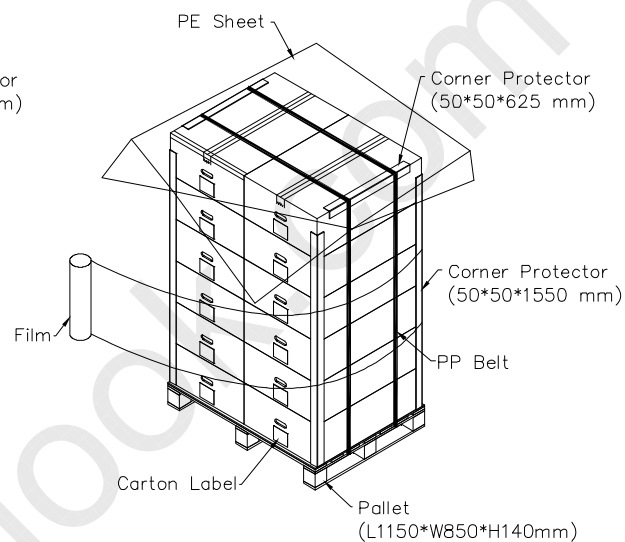

Figure.9-1 packing method

Sea / Land Transportation  
 (40ft HQ Container)



Sea / Land Transportation  
 (40ft Container)



Air Transportation

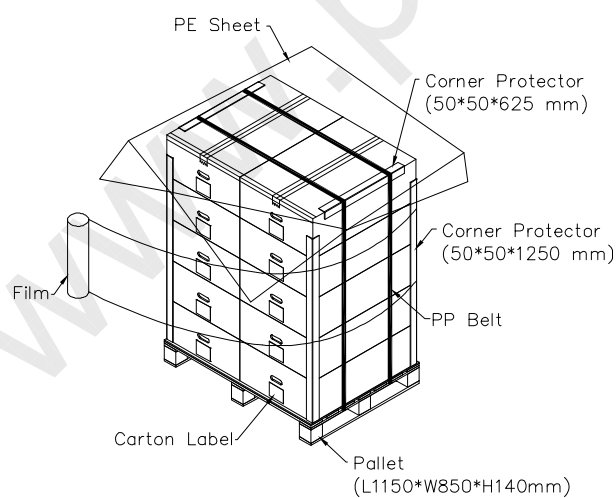

Figure.9-2 packing method

## 10. PRECAUTIONS

### 10.1 ASSEMBLY AND HANDLING PRECAUTIONS

- (1) Do not apply rough force such as bending or twisting to the product during assembly.
- (2) To assemble backlight or install module into user's system can be only in clean working areas. The dust and oil may cause electrical short or worsen the polarizer.
- (3) It's not permitted to have pressure or impulse on the module because the LCD panel will be damaged.
- (4) Always follow the correct power sequence when the product is connecting and operating. This can prevent damage to the CMOS LSI chips during latch-up.
- (5) Do not pull the I/F connector in or out while the module is operating.
- (6) Use a soft dry cloth without chemicals for cleaning, because the surface of polarizer is very soft and easily scratched.
- (7) It is dangerous that moisture come into or contacted the product, because moisture may damage the product when it is operating.
- (8) High temperature or humidity may reduce the performance of module. Please store this product within the specified storage conditions.
- (9) When ambient temperature is lower than 10°C may reduce the display quality. For example, the response time will become slowly.

### 10.2 SAFETY PRECAUTIONS

- (1) If the liquid crystal material leaks from the panel, it should be kept away from the eyes or mouth. In case of contact with hands, skin or clothes, it has to be washed away thoroughly with soap.
- (2) After the product's end of life, it is not harmful in case of normal operation and storage.

## 11. REGULATORY STANDARDS

### 11.1 SAFETY

Regulatory	Item	Standard
Information Technology equipment	UL	UL 60950-1: 2003
	cUL	CAN/CSA C22.2 No.60950-1-03
	CB	IEC 60950-1:2001
Audio/Video Apparatus	UL	UL 60065: 2003
	cUL	CAN/CSA C22.2 No.60065-03
	CB	IEC 60065:2001



### 12. MECHANICAL CHARACTERISTICS

