

TFT LCD Approval Specification

MODEL NO.: V296W1 - L11

Customer: _____

Approved by: _____

Note:

www.DataSheet4U.com

LCD TV Head Division	
Director	郭振隆

Liquid Crystal Display Division			
QRA Dept.	DDIII	DDII	DDI
Approval	Approval	Approval	Approval
陳永一	李汪洋	鈴木優	林文聰

LCD TV Marketing and Product Management Dept.	
Project Manager	黃富瑞

- CONTENTS -

REVISION HISTORY	-----	3
1. GENERAL DESCRIPTION	-----	4
1.1 OVERVIEW		
1.2 FEATURES		
1.3 APPLICATION		
1.4 GENERAL SPECIFICATIONS		
1.5 MECHANICAL SPECIFICATIONS		
2. ABSOLUTE MAXIMUM RATINGS	-----	5
2.1 ABSOLUTE RATINGS OF ENVIRONMENT		
2.2 ELECTRICAL ABSOLUTE RATINGS		
2.2.1 TFT LCD MODULE		
2.2.2 BACKLIGHT UNIT		
3. ELECTRICAL CHARACTERISTICS	-----	6
3.1 TFT LCD MODULE		
3.2 BACKLIGHT INVERTER UNIT		
4. BLOCK DIAGRAM	-----	11
5. INPUT TERMINAL PIN ASSIGNMENT	-----	12
5.1 TFT LCD MODULE		
5.2 BACKLIGHT UNIT		
5.3 INVERTER UNIT		
5.4 BLOCK DIAGRAM OF INTERFACE		
5.5 LVDS INTERFACE		
5.6 COLOR DATA INPUT ASSIGNMENT		
6. INTERFACE TIMING	-----	18
6.1 INPUT SIGNAL TIMING SPECIFICATIONS		
6.2 POWER ON/OFF SEQUENCE		
www.DataSheet4U.com		
7. OPTICAL CHARACTERISTICS	-----	20
7.1 TEST CONDITIONS		
7.2 OPTICAL SPECIFICATIONS		
8. PACKAGING	-----	24
8.1 PACKING SPECIFICATIONS		
8.2 PACKING Method		
9. DEFINITION OF LABELS	-----	26
10. PRECAUTIONS	-----	27
10.1 ASSEMBLY AND HANDLING PRECAUTIONS		
10.2 SAFETY PRECAUTIONS		
11. MECHANICAL CHARACTERISTICS	-----	28

REVISION HISTORY

Version	Date	Page (New)	Section	Description
Ver 2.0	Dec.26,'03	All	All	Approval Specification was first issued.

www.DataSheet4U.com

1. GENERAL DESCRIPTION

1.1 OVERVIEW

V296W1- L11 is a 30" TFT Liquid Crystal Display module with 16-CCFL Backlight unit and 1ch-LVDS interface. This module supports 1280 x 768 WXGA format and can display true 16.7M colors (8-bit/color). The inverter module for backlight is built-in.

1.2 FEATURES

- Ultra wide viewing angle – Super MVA technology
- High brightness (550 nits)
- High contrast ratio (600:1)
- Fast response time
- High color saturation NTSC 75%
- WXGA (1280 x 768 pixels) resolution
- DE (Data Enable) only mode
- LVDS (Low Voltage Differential Signaling) interface

1.3 APPLICATION

- TFT LCD TVs

1.4 GENERAL SPECIFICATIONS

Item	Specification	Unit	Note
Active Area	643.2(H) x 385.92 (V) (29.53" diagonal)	mm	(1)
Bezel Opening Area	648.8 (H) x 391.52 (V)	mm	
Driver Element	a-si TFT active matrix	-	-
Pixel Number	1280 x R.G.B. x 768	pixel	-
Pixel Pitch (Sub Pixel)	0.1675 (H) x 0.5025 (V)	mm	-
Pixel Arrangement	RGB vertical stripe	-	-
Display Colors	16.7M	color	-
Display Operation Mode	Transmissive mode / Normally black	-	-
Surface Treatment	Anti-glare with anti-reflective coating Hard coating (2H), Haze : 40% Reflection rate : < 2%	-	-

1.5 MECHANICAL SPECIFICATIONS

Item	Min.	Typ.	Max.	Unit	Note
Module Size	Horizontal(H)	683.6		mm	(1), (2)
	Vertical(V)	433.6		mm	
	Depth(D)	-		43	
Weight	-	5500		g	-

Note (1) Please refer to the attached drawings for more information of front and back outline dimensions.

Note (2) Module Depth does not include connectors.

2. ABSOLUTE MAXIMUM RATINGS

2.1 ABSOLUTE RATINGS OF ENVIRONMENT

Item	Symbol	Value		Unit	Note
		Min.	Max.		
Storage Temperature	T _{ST}	-20	+60	°C	(1)
Operating Ambient Temperature	T _{OP}	0	+50	°C	(1), (2)
Shock (Non-Operating)	S _{NOF}	-	100	G	(3), (5)
Vibration (Non-Operating)	V _{NOF}	-	1.0	G	(4), (5)

Note (1) Temperature and relative humidity range is shown in the figure below.

- (a) 90 %RH Max. (Ta ≤ 40 °C).
- (b) Wet-bulb temperature should be 39 °C Max. (Ta > 40 °C).
- (c) No condensation.

Note (2) The maximum operating temperature is based on the test condition that the surface temperature of display area is less than or equal to 60 °C with LCD module alone in a temperature controlled chamber. Thermal management should be considered in your product design to prevent the surface temperature of display area from being over 60 °C. The range of operating temperature may degrade in case of improper thermal management in your product design.

Note (3) 2 ms, half sine wave, 1 time for ± X, ± Y, ± Z.

Note (4) 10 ~ 500 Hz, 10 min, 1 time each X, Y, Z.

Note (5) At testing Vibration and Shock, the fixture in holding the module has to be hard and rigid enough so that the module would not be twisted or bent by the fixture.

Relative Humidity (%RH)

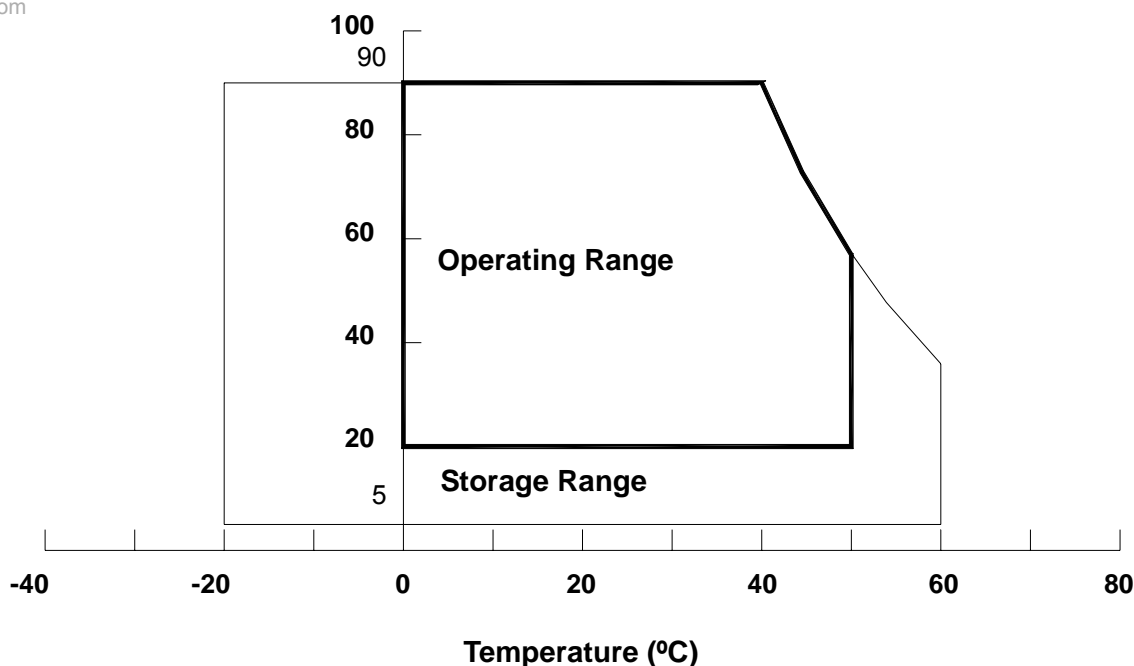

www.DataSheet4U.com

2.2 ELECTRICAL ABSOLUTE RATINGS

2.2.1 TFT LCD MODULE

Item	Symbol	Value		Unit	Note
		Min.	Max.		
Power Supply Voltage	V _{CC}	-0.3	+6.0	V	(1)
Logic Input Voltage	V _{IN}	-0.3	4.3	V	

2.2.2 BACKLIGHT UNIT

Item	Symbol	Test Condition	Min.	Type	Max.	Unit	Note
Lamp Voltage	V _W	T _a = 25	-	-	3000	V _{RMS}	
Input Voltage	V _{BL}	-	0	-	30	V	(1), (2), I _L = 4.5 mA
On/Off Control Voltage	V _{BLON}	-	-0.3	-	7	V	(1), (2)
Internal/External PWM Select Voltage	V _{SEL}	-					
Internal PWM Control Voltage	V _{IPWM}	-					
External PWM Control Voltage	V _{EPWM}	-					
Operating Temperature	T _{OP}	5 95% RH	0	-	75		(3)
Storage Temperature	T _{ST}	5 95% RH	-30	-	80		

Note (1) Permanent damage to the device may occur if maximum values are exceeded. Function operation should be restricted to the conditions described under Normal Operating Conditions.

Note (2) Specified values are for lamp and inverter (Refer to 3.2 for further information).

Note (3) Protect inverters from moisture condensation and freezing.

3. ELECTRICAL CHARACTERISTICS

3.1 TFT LCD MODULE

 T_a = 25 ± 2 °C

Parameter	Symbol	Value			Unit	Note
		Min.	Typ.	Max.		
Power Supply Voltage	V _{CC}	4.5	5.0	5.5	V	-
Ripple Voltage	V _{RP}	-	-	200	mV	-
Rush Current	I _{RUSH}	-	-	3.0	A	(2)
Power Supply Current	White	-	1.5	-	A	(3)a
	Black	-	0.8	-	A	(3)b
	Vertical Stripe	-	1.2	-	A	(3)c
LVDS differential input high threshold voltage	V _{TH}	-	-	+100	mV	
LVDS differential input low threshold voltage	V _{TL}	-100	-	-	mV	
LVDS common input voltage	V _{IC}	1.125	1.25	1.375	V	
Terminating Resistor	R _T	-	100	-	ohm	

Note (1) The module should be always operated within above ranges.

Note (2) Measurement Conditions:

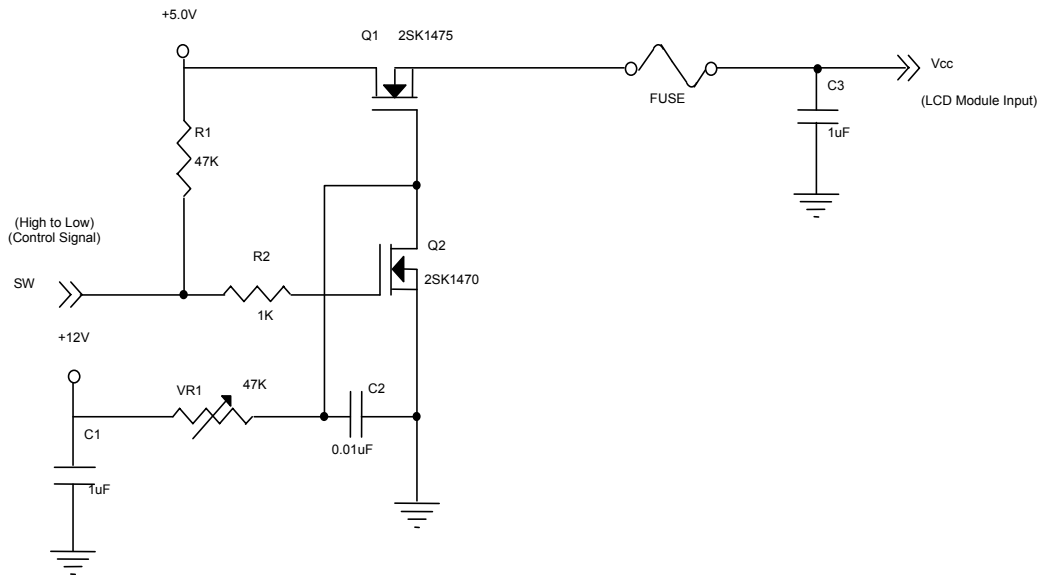

Vcc rising time is 470μs

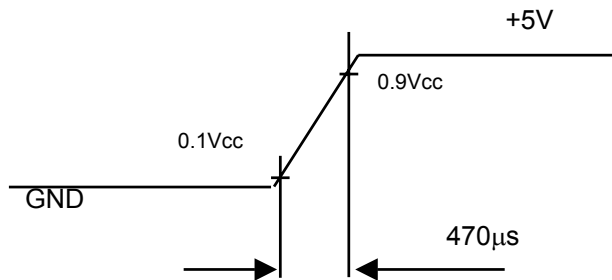

www.DataSheet4U.com

Note (3) The specified power supply current is under the conditions at $V_{cc} = 5\text{ V}$, $T_a = 25 \pm 2\text{ }^\circ\text{C}$, $f_v = 60\text{ Hz}$, whereas a power dissipation check pattern below is displayed.

a. White Pattern



Active Area

b. Black Pattern



Active Area

c. Vertical Stripe Pattern

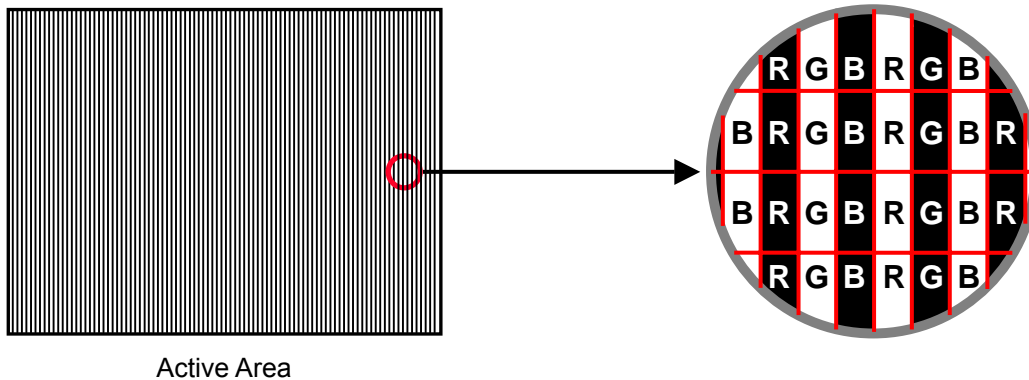

3.2 BACKLIGHT INVERTER UNIT

3.2.1 Initial Characteristics

Ta = 25 ± 2 °C

Parameter	Symbol	Value			Unit	Note
		Min.	Typ.	Max.		
Power Consumption	P _{BL}	-	106	-	W	(4), (7), I _L = 4.5mA
Input Voltage	V _{BL}	21.6	24	26.4	V _{DC}	
Lamp Voltage	V _W	1053	1170	1287	V _{RMS}	I _L = 4.5mA
Lamp Current	I _L	4.2	4.5	4.8	mA _{RMS}	(1)
Open Lamp Voltage	V _S	1560	-	3000	V _{RMS}	(2), Ta = 25 °C
		1870	-	3000	V _{RMS}	(2), Ta = 0 °C
Oscillating Frequency	F _W	57	60	63	KHz	(3)
Lamp Life Time	L _{BL}	50K	-	-	Hrs	(5)

Note (1) Lamp current is measured by utilizing high frequency current meters as shown below:

www.DataSheet4U.com

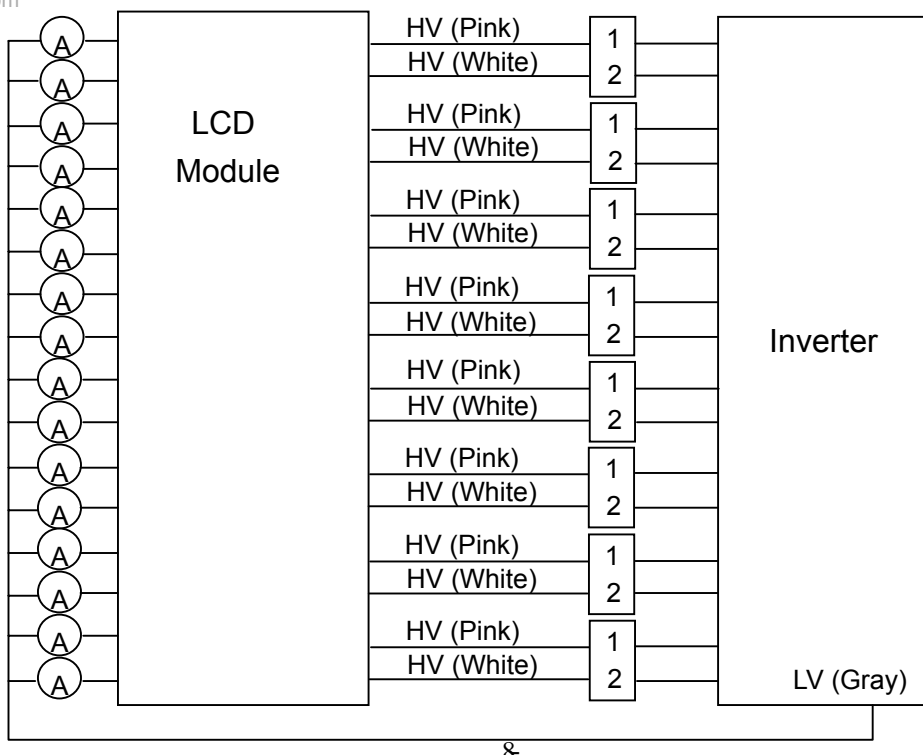

Note (2) The open lamp voltage V_s should be applied to the lamp for more than 1 second after startup. Otherwise the lamp may not be turned on.

Note (3) The lamp frequency may produce interference with horizontal synchronous frequency from the display, and this may cause line flow on the display. In order to avoid interference, the lamp frequency should be detached from the horizontal synchronous frequency and its harmonics as far as possible.

Note (5) The life time of a lamp is defined as the time in which it continues to operate under the condition $T_a = 25 \pm 2$ and $I_L = 4.2 \sim 4.8$ mA rms until one of the following events occurs:

(a) When the brightness becomes equal or less than 50% of its original value.

(b) When the effective discharge length becomes equal or lower than 80% of its original value.

(Effective discharge length is defined as an area that has equal or more than 70% brightness compared to the brightness at the center point.)

Note (6) The waveform of the voltage output of inverter must be area-symmetric and the design of the inverter must have specifications for the modularized lamp. The performance of the Backlight, such as lifetime or brightness, is greatly influenced by the characteristics of the DC-AC inverter for the lamp. All the parameters of an inverter should be carefully designed to avoid producing too much current leakage from high voltage output of the inverter. When designing or ordering the inverter please make sure that a poor lighting caused by the mismatch of the Backlight and the inverter (miss-lighting, flicker, etc.) never occurs. If the above situation is confirmed, the module should be operated in the same manners when it is installed in your instrument.

Note (7) The power source capacity should be 3 times of inverter total power consumption P_{BL} or higher, and add an 0.1uf ceramic capacitor and an 1000uf aluminum capacitor or equivalent which should be paralleled between V_{BL} and ground of input connector in case of inverter malfunction.

Note (8) Requirements for a system inverter design, which is intended to have a better display performance, a better power efficiency and a more reliable lamp, are following. It shall help increase the lamp lifetime and reduce leakage current.

a. The asymmetry rate of the lamp current waveform should be less than 5%.

b. The crest factor of lamp current waveform should be within 1.414 to 1.7.

c. Inverter output waveform had better be more similar to ideal sine wave.

3.2.2 Interface Characteristics

ITEM		SYMBOL	TEST CONDITION	MIN	TYPE	MAX	UNIT	NOTE ⁽²⁻⁴⁾
On/Off Control Voltage	ON	V_{BLON}	-	2.0	-	5.0	V	See Fig.2
	OFF		-	0	-	0.8	V	
Internal/External PWM Select Voltage	HI	V_{SEL}	-	2.0	-	5.0	V	Ext. Dim. Control
	LO		-	0	-	0.8	V	Int. Dim. Control
Internal PWM Control Voltage	MAX	V_{IPWM}	$V_{SEL} = L$	-	-	3.0	V	Minimum Duty Ratio
	MIN		$V_{SEL} = L$	-	0	-	V	Maximum Duty Ratio
External PWM Control Voltage	HI	V_{EPWM}	$V_{SEL} = H$	2.0	-	5.0	V	ON Duration
	LO		$V_{SEL} = H$	0	-	0.8	V	OFF Duration
Control Signal Rising Time		T_r	-	-	-	100	ms	See Fig.2
Control Signal Falling Time		T_f	-	-	-	100	ms	
PWM Signal Rising Time		T_{PWMR}	-	-	-	50	us	
PWM Signal Falling Time		T_{PWMF}	-	-	-	50	us	
Interface Impedance		R_{IN}	-	1	-	-	M	Parallel in (Note 1)
				-	-	0.5	K	Serial in (Note 1)
BLON Delay Time		T_{on}	-	500	-	-	mS	(Note 5)
BLON Off Time		T_{off}	-	500	-	-	mS	

Note (1) Permanent damage to the device may occur if interface impedance are exceeded above definition.

Note (2) All the interface circuits without spike suppress component hence the hot plug in or plug out of all connectors are inhibited.

www.DataSheet4U.com

Note (3) External PWM control signal (E_PWM) should be connected to low in case internal PWM was selected. (SEL = low). Internal PWM control signal (I_PWM) should be connected to ground in case external PWM was selected. (SEL = high), Floating of any control signal is not allowed.

Note (4) For dimming control function operation chart was shown as below.

Note (5) The power on sequence was defined as following. Before BLON signal raised, the input power V_{BL} shall maintain a BLON Delay Time (T_{on}) time in advance.

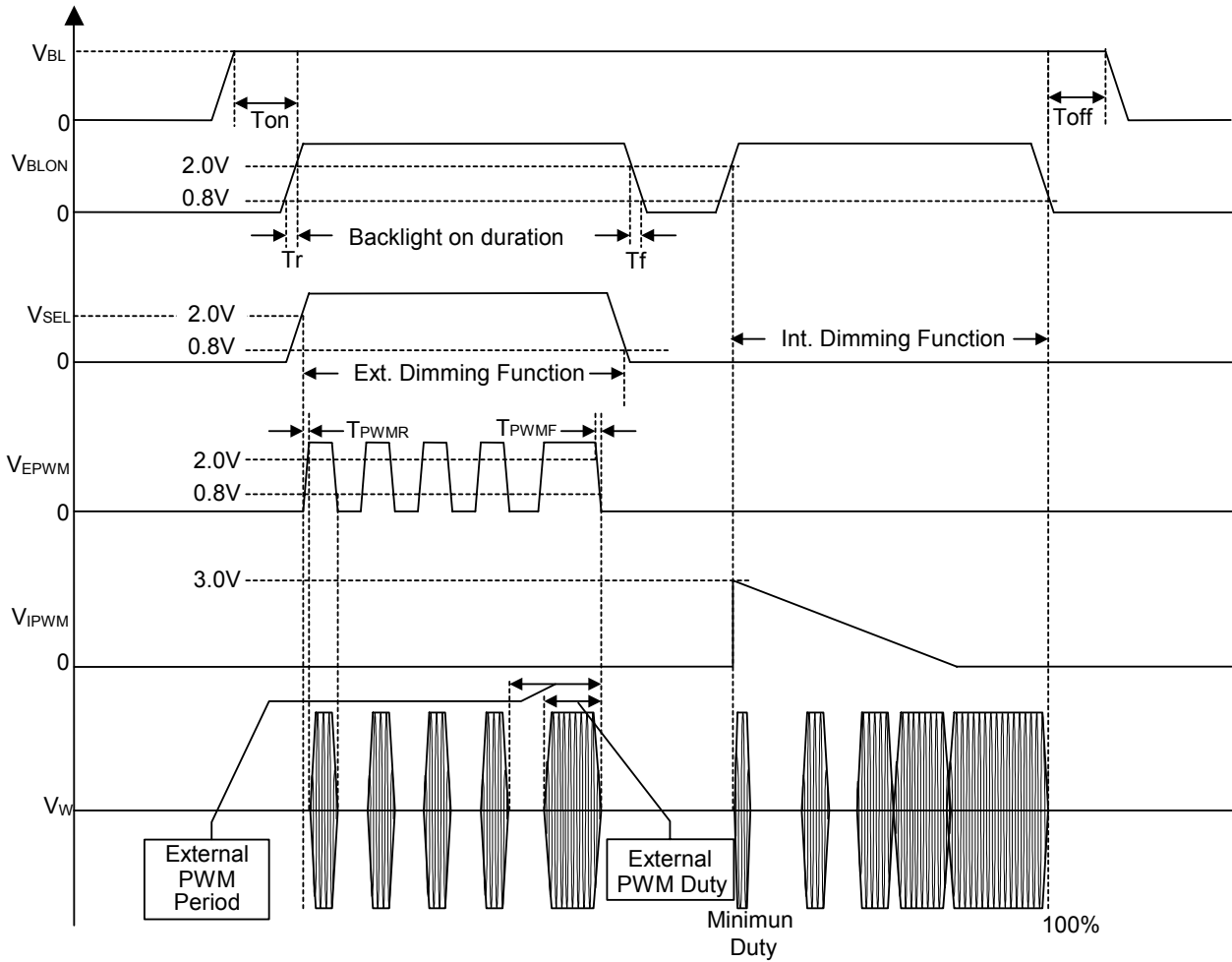

4. BLOCK DIAGRAM

4.1 TFT LCD MODULE

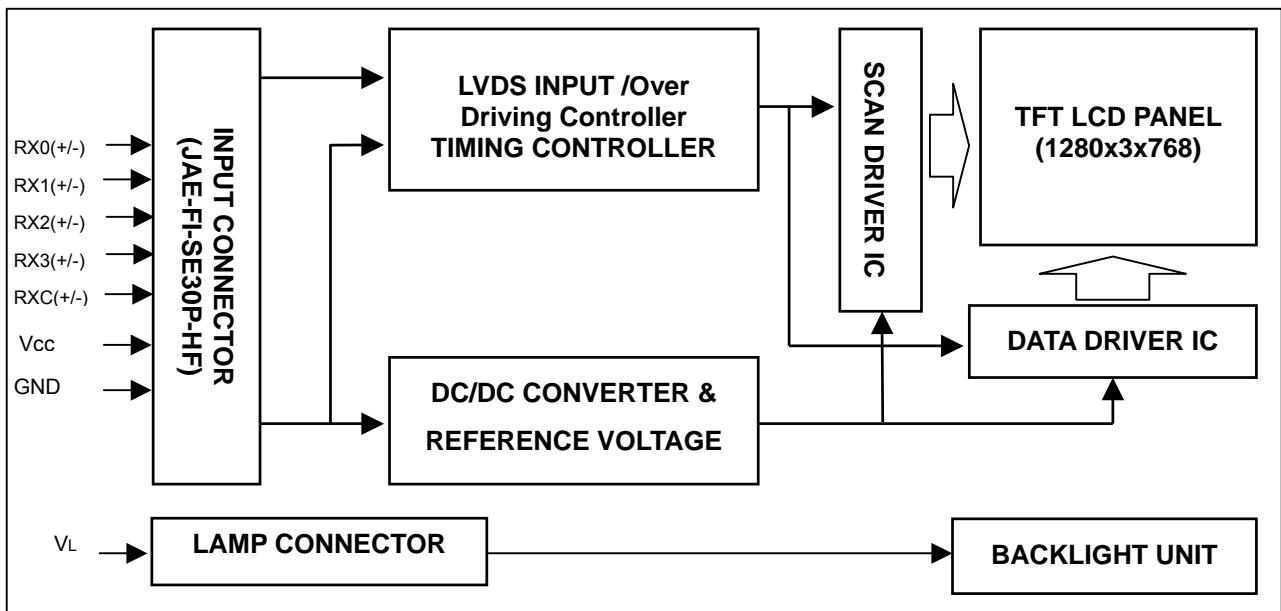

5. INPUT TERMINAL PIN ASSIGNMENT

5.1 TFT LCD MODULE

Pin	Name	Description
1	NC	No Connection
2	NC	No Connection
3	NC	No Connection
4	NC	No Connection
5	NC	No Connection
6	NC	No Connection
7	NC	No Connection
8	GND	Ground
9	RX3+	Positive LVDS differential data input. Channel 3
10	RX3-	Negative LVDS differential data input. Channel 3
11	RXCLK+	Positive LVDS differential clock input.
12	RXCLK-	Negative LVDS differential clock input.
13	GND	Ground
14	GND	Ground
15	RX2+	Positive LVDS differential data input. Channel 2
16	RX2-	Negative LVDS differential data input. Channel 2
17	RX1+	Positive LVDS differential data input. Channel 1
18	RX1-	Negative LVDS differential data input. Channel 1
19	RX0+	Positive LVDS differential data input. Channel 0
20	RX0-	Negative LVDS differential data input. Channel 0
21	GND	Ground
22	GND	Ground
23	GND	Ground
24	GND	Ground
25	GND	Ground
26	VCC	+5.0V power supply
27	VCC	+5.0V power supply
28	VCC	+5.0V power supply
29	VCC	+5.0V power supply
30	VCC	+5.0V power supply

Note (1) Connector Part No.: FI-SE30P-HF (JAE)

Note (2) The first pixel is even.

5.2 BACKLIGHT UNIT

The pin configuration for the connector is shown in the table below.

CN3-CN10: BHR-03-VS-1

Pin No	Signal name	Feature	Wire Color
1	HV	High Voltage	Pink
2	HV	High Voltage	White

Note (1) The backlight interface connector for high voltage side is a model BHR-04VS-1, manufactured by JST.

The mating connector on inverter part number is SM02(8.0)-BHS-1-TB or equivalent.

CN11: ZHR-2 or equivalent

Pin No	Signal name	Feature	Wire Color
1	LV	Low Voltage	Gray
2	NC	No Connection	-

Note (2) The backlight interface connector for low voltage side is a model ZHR-2, manufactured by JST or

equivalent. The mating connector on inverter part number is S2B-ZR-SM3A-TF or equivalent.

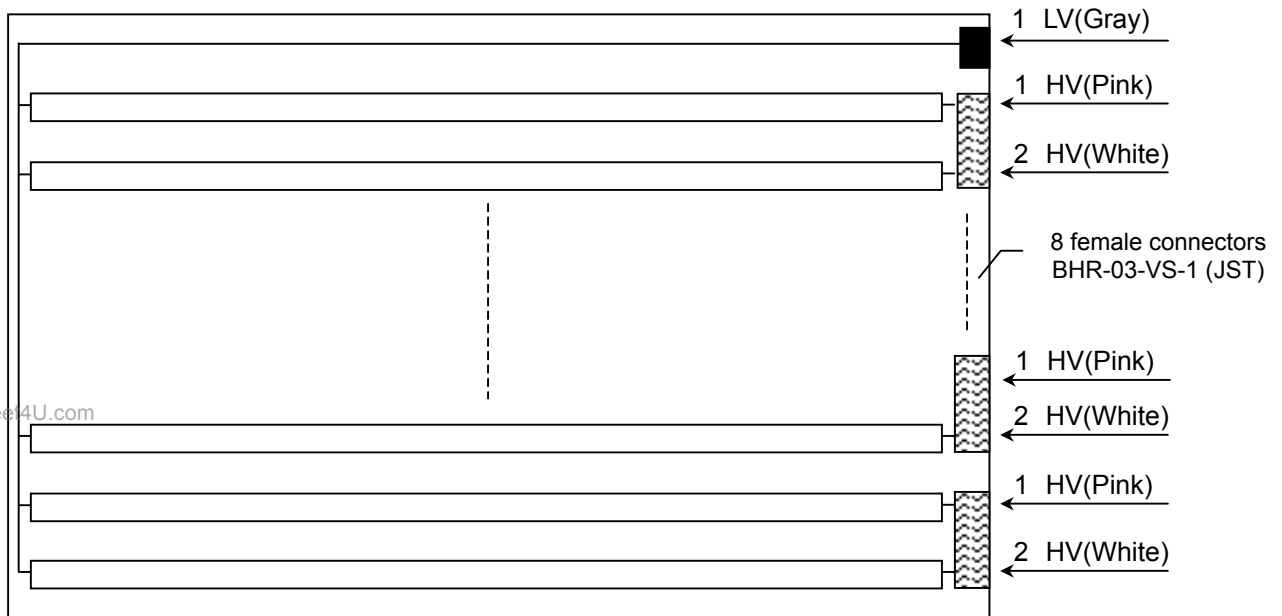

5.3 INVERTER UNIT

Note (1). The inverter input power source connector CN1 is a model S10B-PH-SM3-TB, manufactured by JST or equivalent. The inverter interface connector CN2 for control signal is a model S12B-PH-SM3-TB, manufactured by JST or equivalent.

CN1: S10B-PH-SM3-TB or equivalent

Pin No	Signal name	Feature
1	V _{BL}	+24 V
2		
3		
4		
5		
6	GND	GND
7		
8		
9		
10		

CN2: S12B-PH-SM3-TB or equivalent

Pin No	Signal name	Feature
1	V _{BL}	+24 V
2		
3		
4		
5		
6	GND	GND
7		
8		
9	SEL	Internal/External PWM Selection
10	E_PWM	External PWM Control
11	I_PWM	Internal PWM Control
12	BLON	BL ON/OFF

CN3~10: SM02(8.0)B-BHS-1-TB(JST)

Pin No	Signal name	Feature
1	CFL HOT	CFL High voltage
2	CFL HOT	CFL High voltage

CN11: S2B-ZR-SM3A-TF(JST) or equivalent

Pin No	Signal name	Feature
1	CFL COLD	CFL Low voltage
2	CFL COLD	CFL Low voltage

5.4 BLOCK DIAGRAM OF INTERFACE

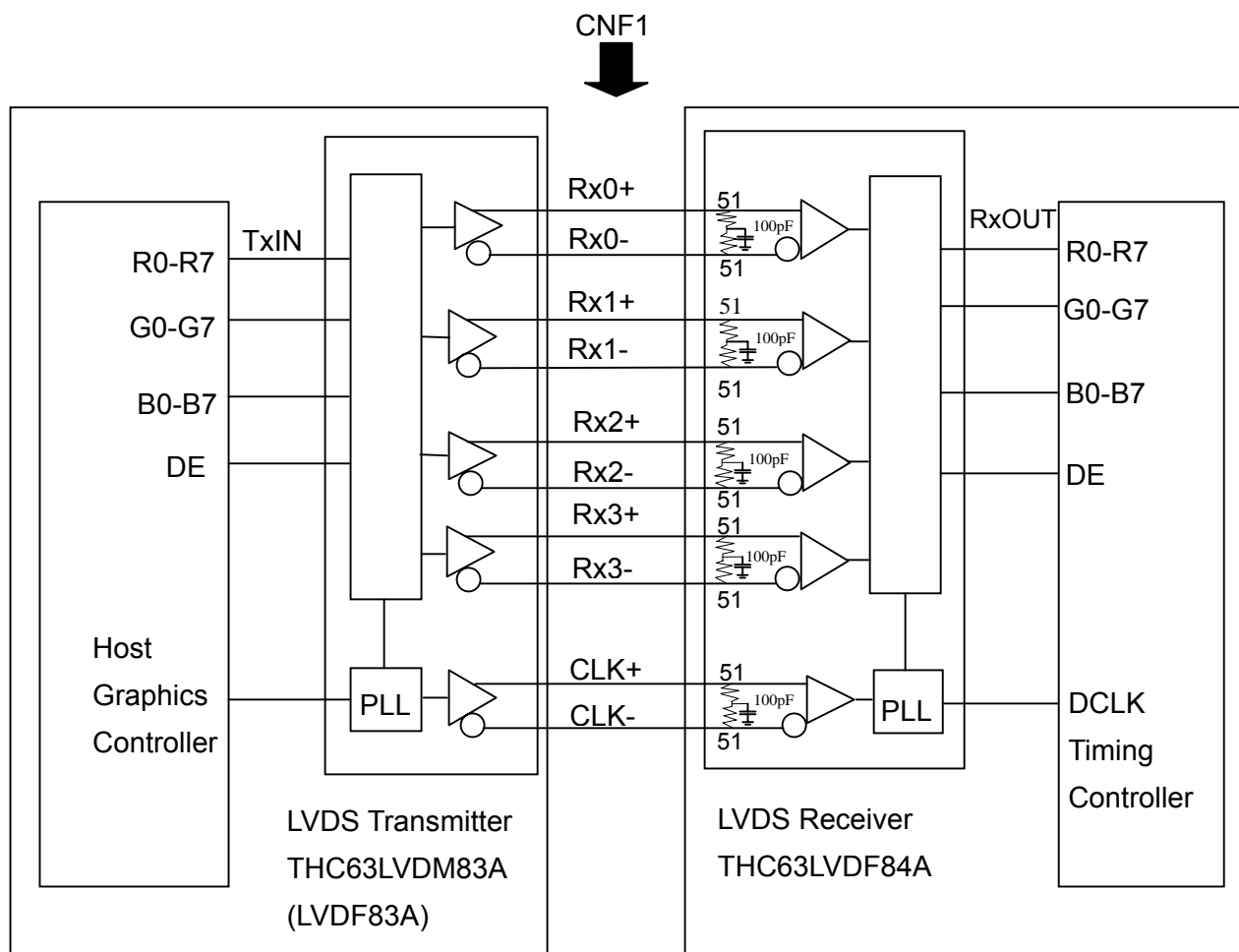

www.DataSheet4U.com

R0~R7 : Pixel R Data ,
 G0~G7 : Pixel G Data ,
 B0~B7 : Pixel B Data ,
 DE : Display timing signal

- Notes: 1) The system must have the transmitter to drive the module.
 2) LVDS cable impedance shall be 50 ohms per signal line or about 100 ohms per twist-pair line when it is used differentially.

5.5 LVDS INTERFACE

	SIGNAL	TRANSMITTER THC63LVDM83A		INTERFACE CONNECTOR		RECEIVER THC63LVDF84A		TFT CONTROL
		PIN	INPUT	Host	TFT-LCD	PIN	OUTPUT	INPUT
24bit	R0	51	TxIN0	TA OUT0+	Rx 0+	27	Rx OUT0	R0
	R1	52	TxIN1			29	Rx OUT1	R1
	R2	54	TxIN2			30	Rx OUT2	R2
	R3	55	TxIN3	TA OUT0-	Rx 0-	32	Rx OUT3	R3
	R4	56	TxIN4			33	Rx OUT4	R4
	R5	3	TxIN6			35	Rx OUT6	R5
	G0	4	TxIN7	TA OUT1+	Rx 1+	37	Rx OUT7	G0
	G1	6	TxIN8			38	Rx OUT8	G1
	G2	7	TxIN9			39	Rx OUT9	G2
	G3	11	TxIN12	TA OUT1-	Rx 1-	43	Rx OUT12	G3
	G4	12	TxIN13			45	Rx OUT13	G4
	G5	14	TxIN14			46	Rx OUT14	G5
	B0	15	TxIN15	TA OUT2+	Rx 2+	47	Rx OUT15	B0
	B1	19	TxIN18			51	Rx OUT18	B1
	B2	20	TxIN19			53	Rx OUT19	B2
	B3	22	TxIN20	TA OUT2-	Rx 2-	54	Rx OUT20	B3
	B4	23	TxIN21			55	Rx OUT21	B4
	B5	24	TxIN22			1	Rx OUT22	B5
	DE	30	TxIN26	TA OUT3+	Rx 3+	6	Rx OUT26	DE
	R6	50	TxIN27			7	Rx OUT27	R6
	R7	2	TxIN5			34	Rx OUT5	R7
	G6	8	TxIN10	TA OUT3-	Rx 3-	41	Rx OUT10	G6
	G7	10	TxIN11			42	Rx OUT11	G7
	B6	16	TxIN16			49	Rx OUT16	B6
B7	18	TxIN17	TA OUT3-	Rx 3-	50	Rx OUT17	B7	
RSVD 1	25	TxIN23			2	Rx OUT23	Not connect	
RSVD 2	27	TxIN24			3	Rx OUT24	Not connect	
RSVD 3	28	TxIN25	5	Rx OUT25	Not connect			
	DCLK	31	TxCLK IN	TxCLK OUT+ TxCLK OUT-	RxCLK IN+ RxCLK IN-	26	RxCLK OUT	DCLK

R0~R7: Pixel R Data (7; MSB, 0; LSB)

G0~G7: Pixel G Data (7; MSB, 0; LSB)

B0~B7: Pixel B Data (7; MSB, 0; LSB)

DE : Display timing signal

Notes: (1)RSVD(reserved)pins on the transmitter shall be "H" or "L".

5.6 COLOR DATA INPUT ASSIGNMENT

The brightness of each primary color (red, green and blue) is based on the 8-bit gray scale data input for the color. The higher the binary input, the brighter the color. The table below provides the assignment of color versus data input.

Color		Data Signal																							
		Red								Green								Blue							
		R7	R6	R5	R4	R3	R2	R1	R0	R7	R6	G5	G4	G3	G2	G1	G0	R7	R6	B5	B4	B3	B2	B1	B0
Basic Colors	Black	0	0	0	0	0	0	0	0	0	0	0	0	0	0	0	0	0	0	0	0	0	0	0	0
	Red	1	1	1	1	1	1	1	1	0	0	0	0	0	0	0	0	0	0	0	0	0	0	0	0
	Green	0	0	0	0	0	0	0	0	1	1	1	1	1	1	1	0	0	0	0	0	0	0	0	0
	Blue	0	0	0	0	0	0	0	0	0	0	0	0	0	0	0	1	1	1	1	1	1	1	1	1
	Cyan	0	0	0	0	0	0	0	0	1	1	1	1	1	1	1	1	1	1	1	1	1	1	1	1
	Magenta	1	1	1	1	1	1	1	1	0	0	0	0	0	0	0	1	1	1	1	1	1	1	1	1
	Yellow	1	1	1	1	1	1	1	1	1	1	1	1	1	1	1	0	0	0	0	0	0	0	0	0
	White	1	1	1	1	1	1	1	1	1	1	1	1	1	1	1	1	1	1	1	1	1	1	1	1
Gray Scale Of Red	Red(0) / Dark	0	0	0	0	0	0	0	0	0	0	0	0	0	0	0	0	0	0	0	0	0	0	0	
	Red(1)	0	0	0	0	0	0	0	1	0	0	0	0	0	0	0	0	0	0	0	0	0	0	0	
	Red(2)	0	0	0	0	0	0	1	0	0	0	0	0	0	0	0	0	0	0	0	0	0	0	0	
	⋮	⋮	⋮	⋮	⋮	⋮	⋮	⋮	⋮	⋮	⋮	⋮	⋮	⋮	⋮	⋮	⋮	⋮	⋮	⋮	⋮	⋮	⋮	⋮	
	⋮	⋮	⋮	⋮	⋮	⋮	⋮	⋮	⋮	⋮	⋮	⋮	⋮	⋮	⋮	⋮	⋮	⋮	⋮	⋮	⋮	⋮	⋮	⋮	
	⋮	⋮	⋮	⋮	⋮	⋮	⋮	⋮	⋮	⋮	⋮	⋮	⋮	⋮	⋮	⋮	⋮	⋮	⋮	⋮	⋮	⋮	⋮	⋮	
	Red(253)	1	1	1	1	1	1	0	1	0	0	0	0	0	0	0	0	0	0	0	0	0	0	0	
	Red(254)	1	1	1	1	1	1	1	0	0	0	0	0	0	0	0	0	0	0	0	0	0	0	0	
Red(255)	1	1	1	1	1	1	1	1	0	0	0	0	0	0	0	0	0	0	0	0	0	0	0		
Gray Scale Of Green	Green(0) / Dark	0	0	0	0	0	0	0	0	0	0	0	0	0	0	0	0	0	0	0	0	0	0	0	
	Green(1)	0	0	0	0	0	0	0	0	0	0	0	0	0	0	1	0	0	0	0	0	0	0	0	
	Green(2)	0	0	0	0	0	0	0	0	0	0	0	0	0	1	0	0	0	0	0	0	0	0	0	
	⋮	⋮	⋮	⋮	⋮	⋮	⋮	⋮	⋮	⋮	⋮	⋮	⋮	⋮	⋮	⋮	⋮	⋮	⋮	⋮	⋮	⋮	⋮	⋮	
	⋮	⋮	⋮	⋮	⋮	⋮	⋮	⋮	⋮	⋮	⋮	⋮	⋮	⋮	⋮	⋮	⋮	⋮	⋮	⋮	⋮	⋮	⋮	⋮	
	⋮	⋮	⋮	⋮	⋮	⋮	⋮	⋮	⋮	⋮	⋮	⋮	⋮	⋮	⋮	⋮	⋮	⋮	⋮	⋮	⋮	⋮	⋮	⋮	
	Green(253)	0	0	0	0	0	0	0	0	1	1	1	1	1	1	0	1	0	0	0	0	0	0	0	
	Green(254)	0	0	0	0	0	0	0	0	1	1	1	1	1	1	1	0	0	0	0	0	0	0	0	
Green(255)	0	0	0	0	0	0	0	0	1	1	1	1	1	1	1	1	0	0	0	0	0	0	0		
Gray Scale Of Blue	Blue(0) / Dark	0	0	0	0	0	0	0	0	0	0	0	0	0	0	0	0	0	0	0	0	0	0	0	
	Blue(1)	0	0	0	0	0	0	0	0	0	0	0	0	0	0	0	0	0	0	0	0	0	0	1	
	Blue(2)	0	0	0	0	0	0	0	0	0	0	0	0	0	0	0	0	0	0	0	0	0	0	1	
	⋮	⋮	⋮	⋮	⋮	⋮	⋮	⋮	⋮	⋮	⋮	⋮	⋮	⋮	⋮	⋮	⋮	⋮	⋮	⋮	⋮	⋮	⋮	⋮	
	⋮	⋮	⋮	⋮	⋮	⋮	⋮	⋮	⋮	⋮	⋮	⋮	⋮	⋮	⋮	⋮	⋮	⋮	⋮	⋮	⋮	⋮	⋮	⋮	
	⋮	⋮	⋮	⋮	⋮	⋮	⋮	⋮	⋮	⋮	⋮	⋮	⋮	⋮	⋮	⋮	⋮	⋮	⋮	⋮	⋮	⋮	⋮	⋮	
	Blue(253)	0	0	0	0	0	0	0	0	0	0	0	0	0	0	0	1	1	1	1	1	1	1	0	
	Blue(254)	0	0	0	0	0	0	0	0	0	0	0	0	0	0	0	1	1	1	1	1	1	1	0	
Blue(255)	0	0	0	0	0	0	0	0	0	0	0	0	0	0	0	1	1	1	1	1	1	1	1		

Note (1) 0: Low Level Voltage, 1: High Level Voltage

6. INTERFACE TIMING

6.1 INPUT SIGNAL TIMING SPECIFICATIONS

The input signal timing specifications are shown as the following table and timing diagram.

Signal	Item	Symbol	Min.	Typ.	Max.	Unit	Note
Clock	Frequency	1/Tc	62	81	82	MHZ	-
Vertical Active Display Term	Frame Rate	Fr	-	60	64	Hz	Tv=Tvd+Tvb
	Total	Tv	780	806	850	Th	-
	Display	Tvd	768	768	768	Th	-
	Blank	Tvb	12	38	82	Th	-
Horizontal Active Display Term	Total	Th	1450	1688	2000	Tc	Th=Thd+Thb
	Display	Thd	1280	1280	1280	Tc	-
	Blank	Thb	170	408	720	Tc	-

Note: Because of this module is operated by DE only mode, Hsync and Vsync input signals should be set to low logic level or ground. Otherwise, this module would operate abnormally.

INPUT SIGNAL TIMING DIAGRAM

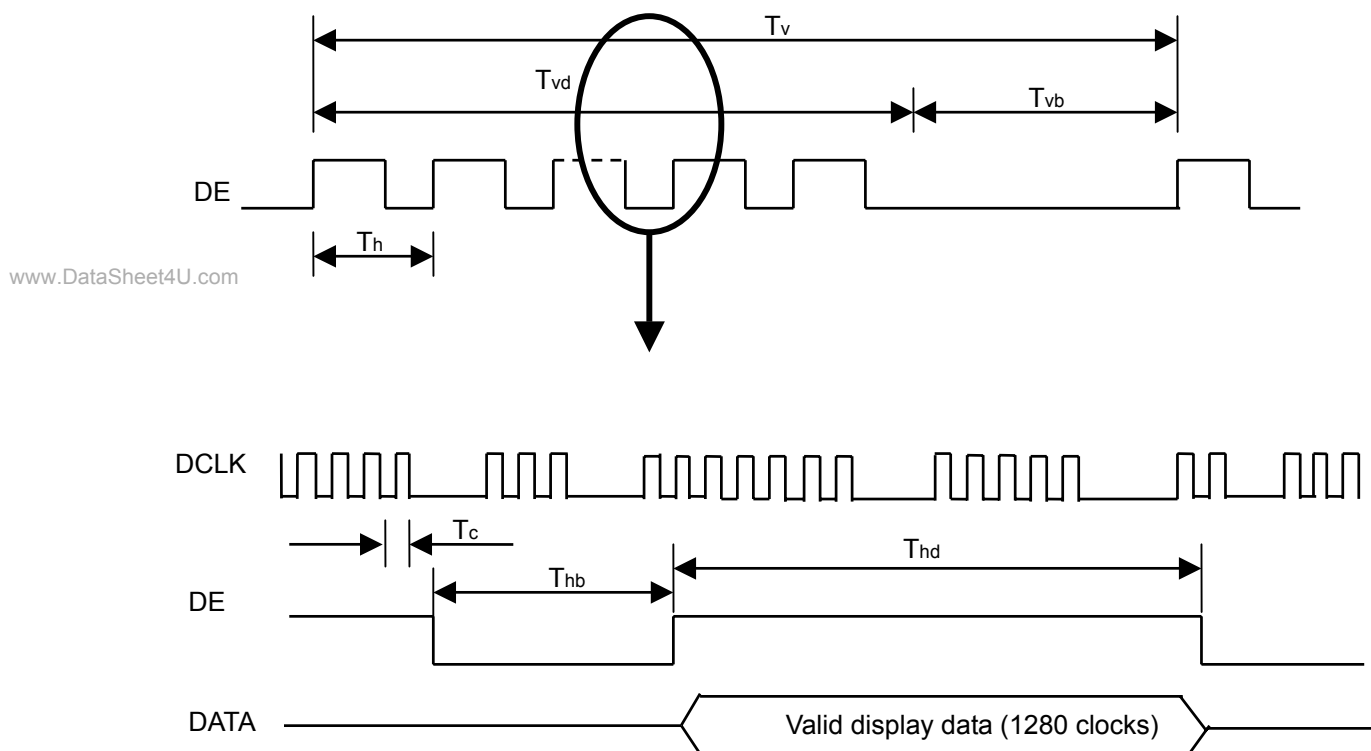

6.2 POWER ON/OFF SEQUENCE

To prevent a latch-up or DC operation of LCD module, the power on/off sequence should be as the diagram below.

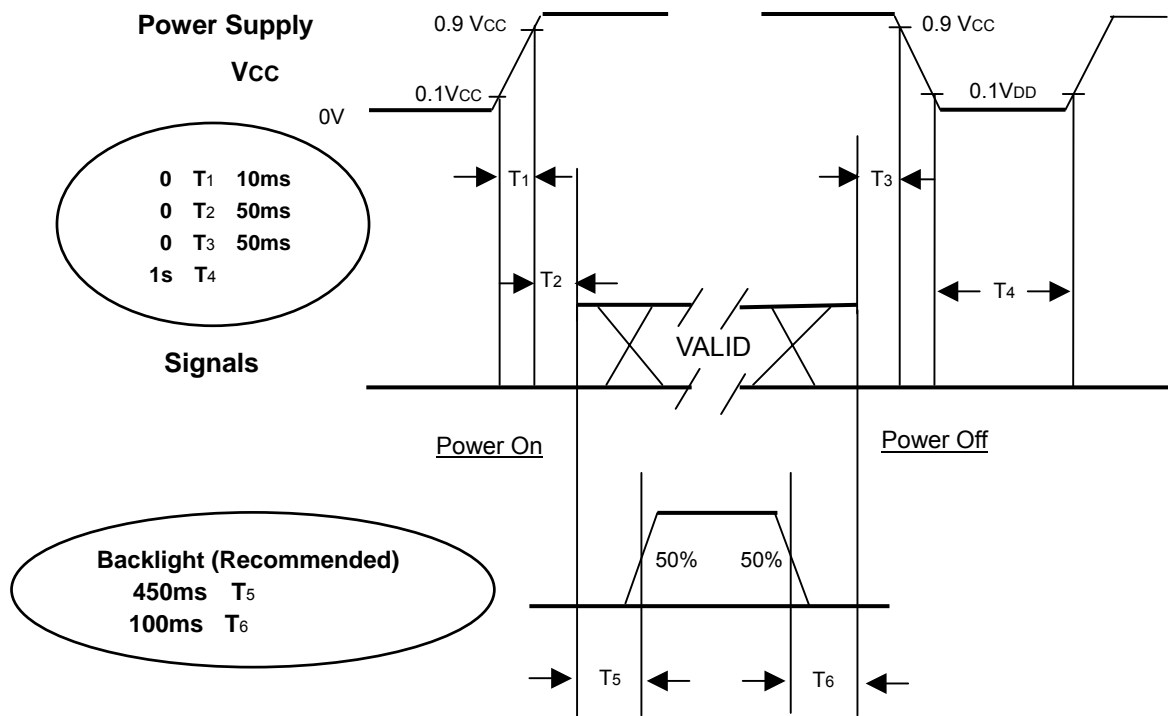

Power ON/OFF Sequence

www.DataSheet4U.com

Note.

- (1) The supply voltage of the external system for the module input should be the same as the definition of Vcc.
- (2) Apply the lamp voltage within the LCD operation range. When the backlight turns on before the LCD operation of the LCD turns off before the backlight turns off, the display may momentarily become abnormal screen.
- (3) In case of vcc = off level, please keep the level of input signals on the low or keep a high impedance.
- (4) T4 should be measured after the module has been fully discharged between power off and on period.
- (5) Interface signal shall not be kept at high impedance when the power is on.

7. OPTICAL CHARACTERISTICS

7.1 TEST CONDITIONS

Item	Symbol	Value	Unit
Ambient Temperature	T _a	25±2	°C
Ambient Humidity	H _a	50±10	%RH
Supply Voltage	V _{CC}	5.0	V
Input Signal	According to typical value in "3. ELECTRICAL CHARACTERISTICS"		
Inverter Current	I _L	4.5	mA
Inverter Driving Frequency	F _L	60	KHz
Inverter		--	

7.2 OPTICAL SPECIFICATIONS

The relative measurement methods of optical characteristics are shown in 7.2. The following items should be measured under the test conditions described in 7.1 and stable environment shown in Note (7).

Item	Symbol	Condition	Min.	Typ.	Max.	Unit	Note	
Contrast Ratio	CR	θ _x =0°, θ _y =0° Viewing Normal Angle	400	600	-	-	Note(2)	
Response Time	T _R		-	15	25	ms	Note(3)	
	T _F		-	10	20	ms		
	Gray to gray				16.6	25	ms	Note(4)
Center Luminance of White	L _C		450	550	-	cd/m ²	Note(5)	
Average Luminance of White	L _{AVE}		400	450	-	cd/m ²		
White Variation	δW		-	-	1.3	-	Note(8)	
Cross Talk	CT		-	-	4.0	%	Note(6)	
Color Chromaticity	Red		R _x	0.614	0.644	0.674	-	9, 300K
			R _y	0.301	0.331	0.361	-	
	Green		G _x	0.240	0.270	0.300	-	
			G _y	0.574	0.604	0.634	-	
	Blue		B _x	0.112	0.142	0.172	-	
			B _y	0.044	0.074	0.114	-	
	White		W _x	0.255	0.285	0.315	-	
			W _y	0.263	0.293	0.323	-	
Color Gamut	CG		72	75		%	NTSC Ratio	
Viewing Angle	Horizontal	θ _{x+}	80	85	-	Deg.	Note(1) No gray scale inversion	
		θ _{x-}	80	85	-			
	Vertical	θ _{y+}	80	85	-			
		θ _{y-}	80	85	-			

Note (1) Definition of Viewing Angle (θ_x, θ_y):

Viewing angles are measured by EZ-Contrast 160R (Eldim)

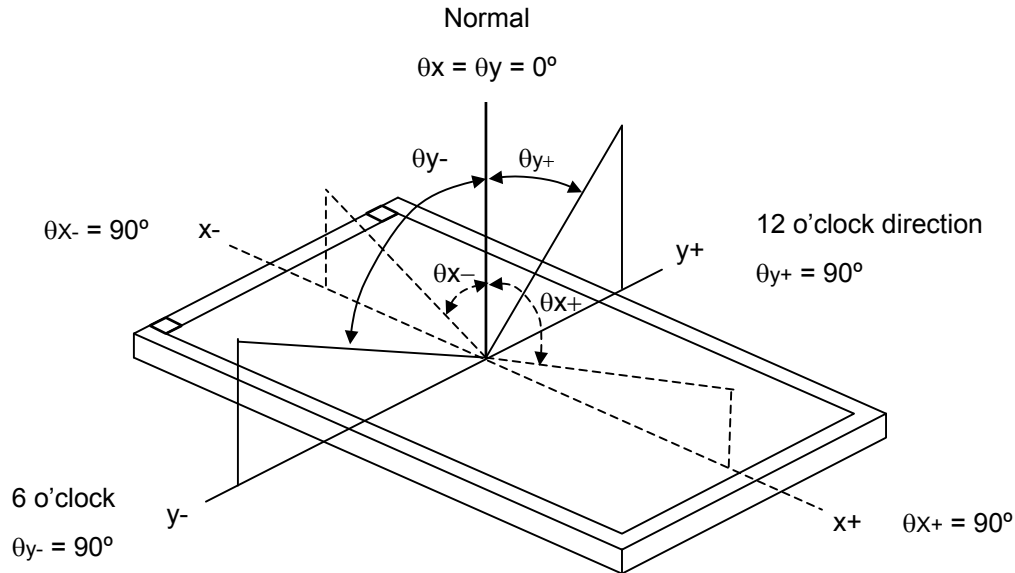

Note (2) Definition of Contrast Ratio (CR):

The contrast ratio can be calculated by the following expression.

$$\text{Contrast Ratio (CR)} = L_{255} / L_0$$

L255: Luminance of gray level 255

L 0: Luminance of gray level 0

www.DataSheet4U.com CR = CR (5)

CR (X) is corresponding to the Contrast Ratio of the point X at the figure in Note (8).

Note (3) Definition of Response Time (T_R, T_F):

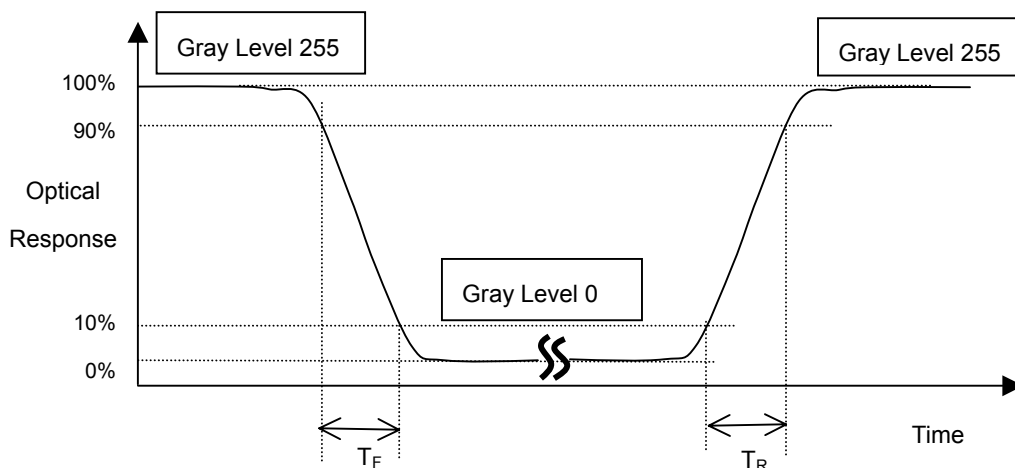

Note (4) Definition of Gray to Gray Switching Time:

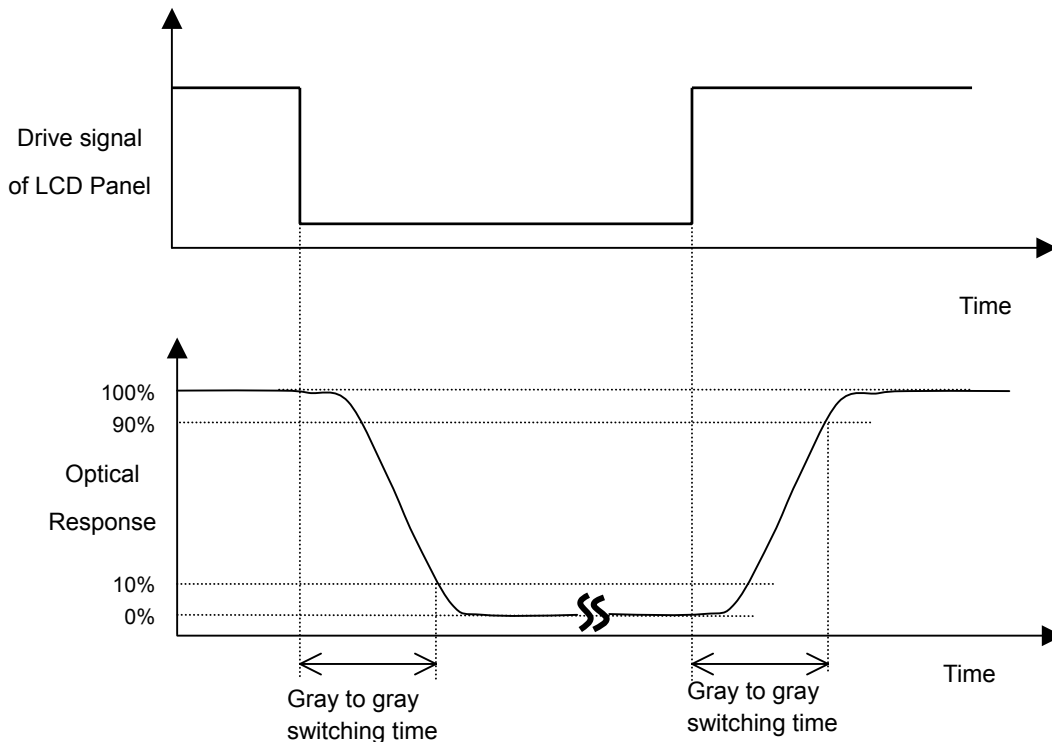

The driving signal means the signal of gray level 0, 63, 127, 191, 255.

Note (5) Definition of Luminance of White (L_C , L_{AVE}):

Measure the luminance of gray level 255 at center point and 5 points

$$L_C = L(5)$$

$$L_{AVE} = [L(1) + L(2) + L(3) + L(4) + L(5)] / 5$$

$L(x)$ is corresponding to the luminance of the point X at the figure in Note (8).

Note (6) Definition of Cross Talk (CT):

$$CT = |Y_B - Y_A| / Y_A \times 100 (\%)$$

Where:

Y_A = Luminance of measured location without gray level 0 pattern (cd/m^2)

Y_B = Luminance of measured location with gray level 0 pattern (cd/m^2)

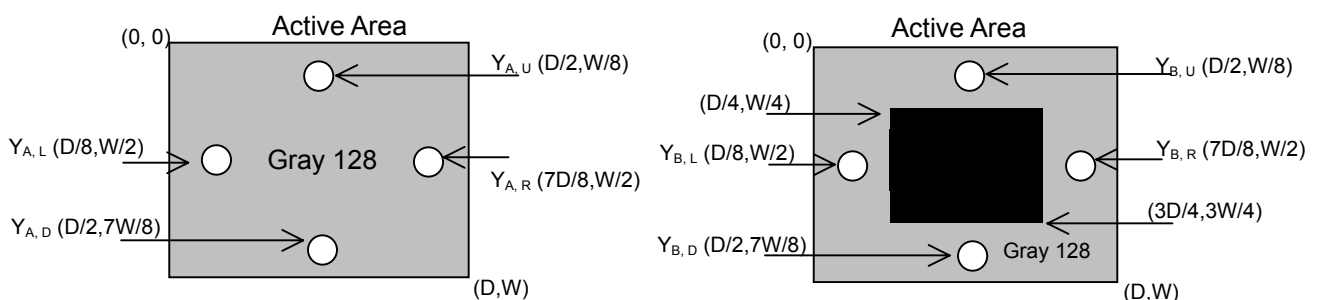

Note (7) Measurement Setup:

The LCD module should be stabilized at given temperature for 1 hour to avoid abrupt temperature change during measuring. In order to stabilize the luminance, the measurement should be executed after lighting Backlight for 1 hour in a windless room.

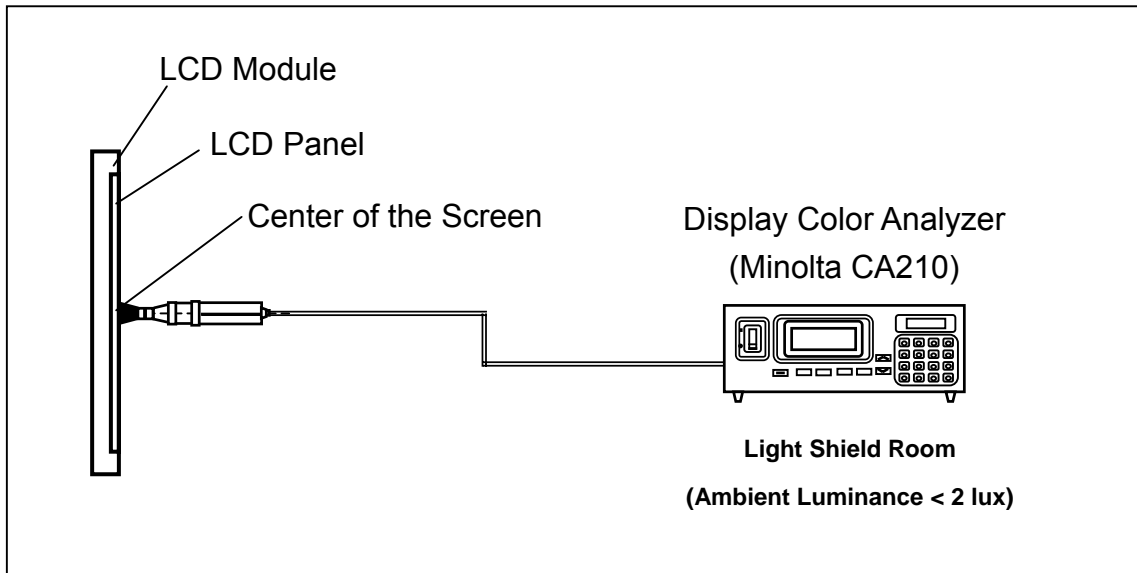

Note (8) Definition of White Variation (δW):

Measure the luminance of gray level 255 at 5 points

$$\delta W = \text{Maximum} [L (1), L (2), L (3), L (4), L (5)] / \text{Minimum} [L (1), L (2), L (3), L (4), L (5)]$$

www.DataSheet4U.com

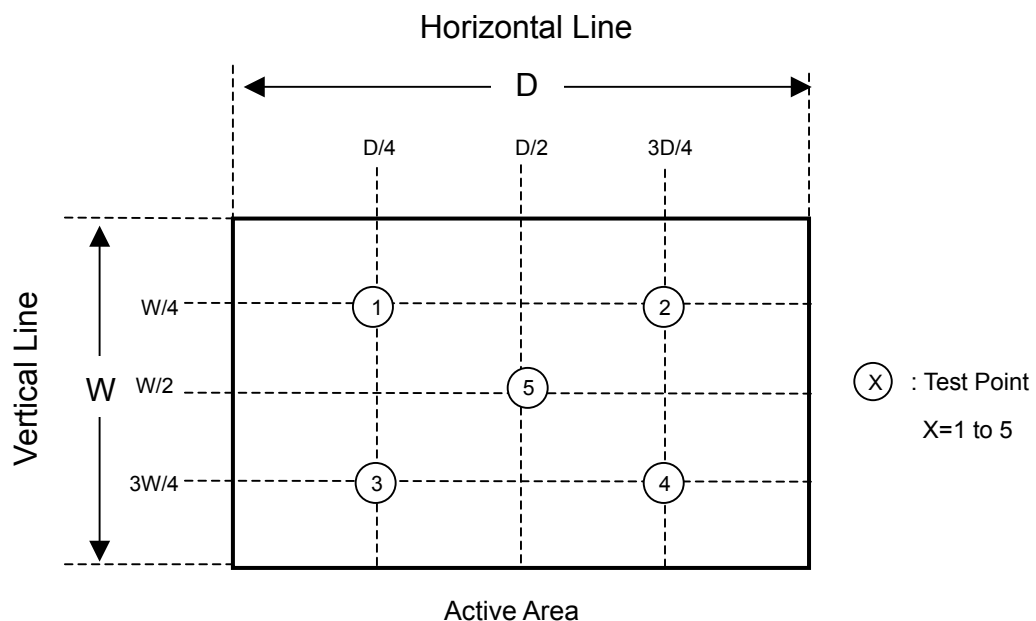

8. PACKAGING

8.1 PACKING SPECIFICATIONS

- (1) 3 LCD TV modules / 1 Box
- (2) Box dimensions : 790(L) X 280 (W) X 564 (H)
- (3) Weight : approximately 19Kg (3 modules per box)

8.2 PACKING Method

Figures 8-1 and 8-2 are the packing method

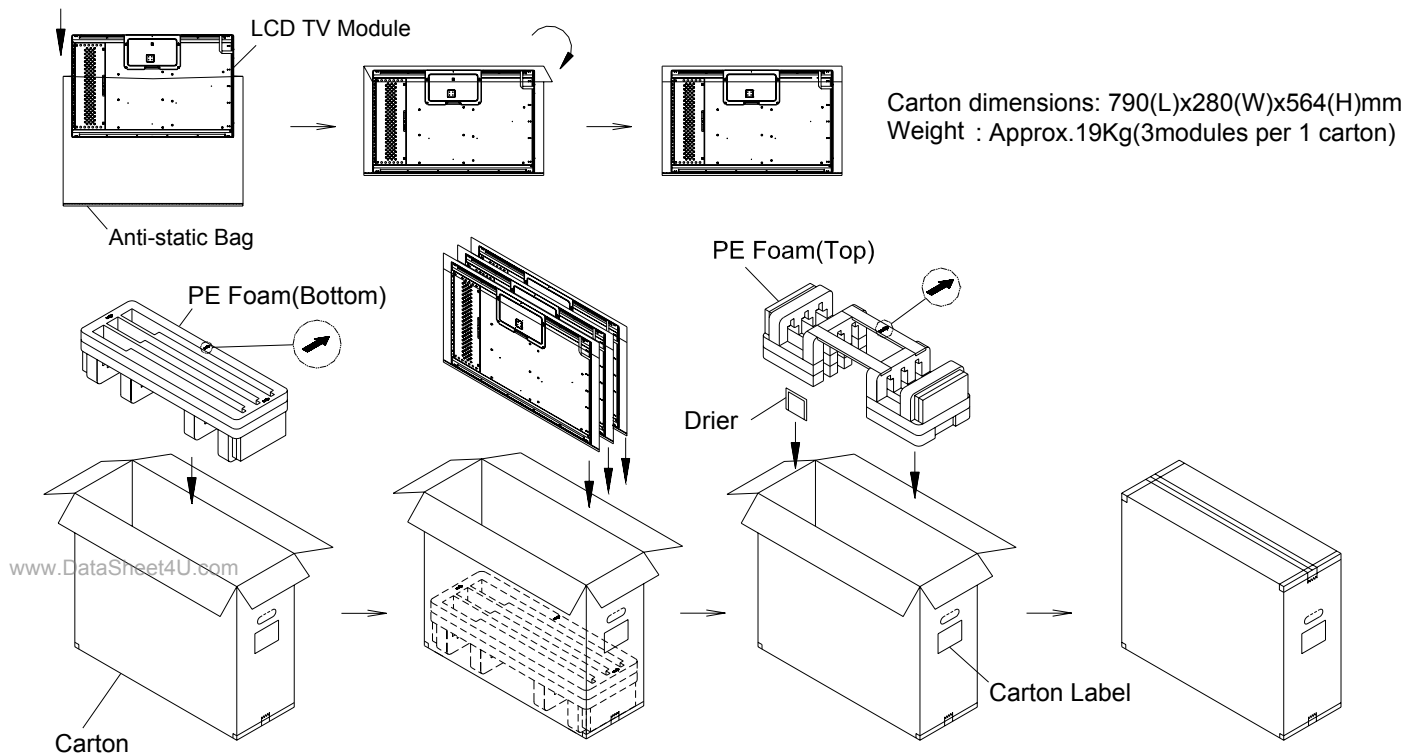

Figure.8-1 packing method

Corner Protector:L1130*50mm*50mm
Pallet:L1100*W1100*H135mm
Bottom Cap:L1100*W1100*H120mm
Pallet stack:L1100*W1100*H1273mm
Gross Weight:175kg

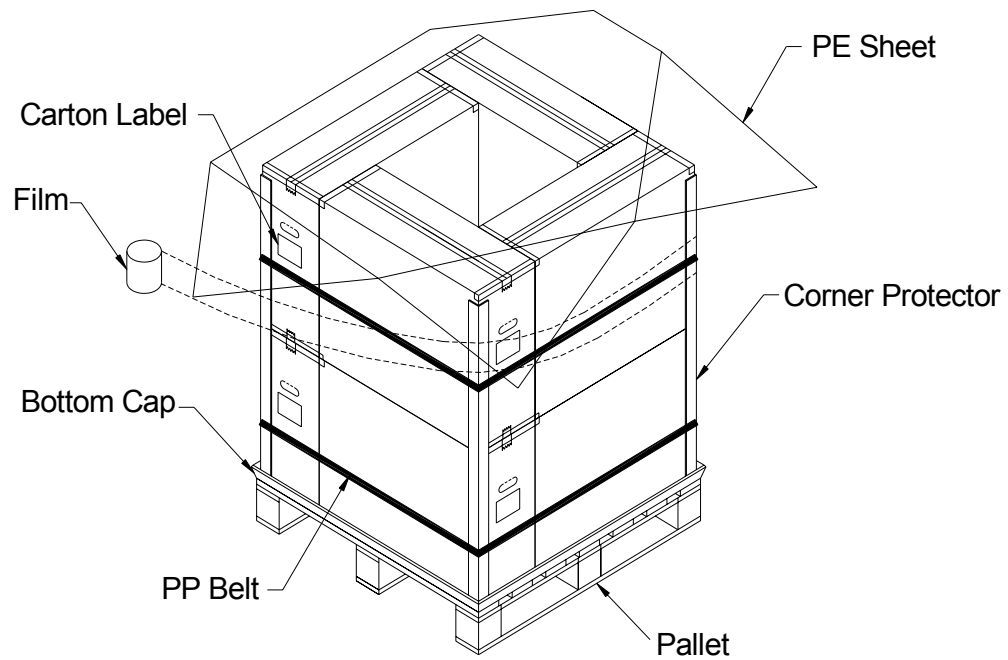
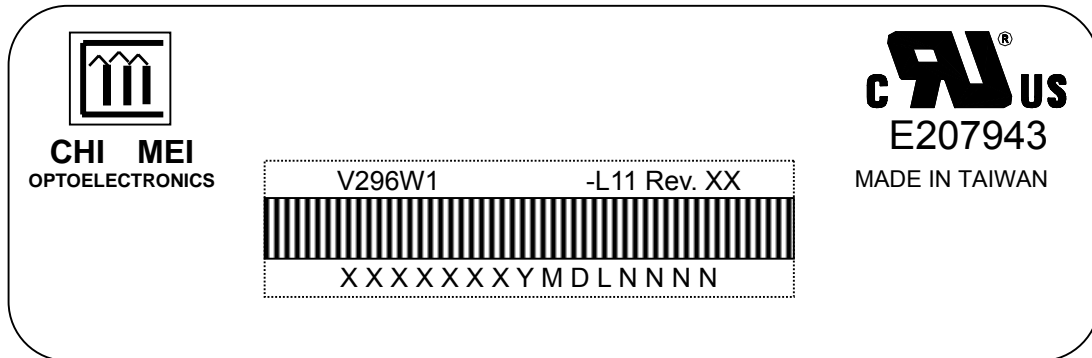

Figure.8-2 packing method

9. DEFINITION OF LABELS

9.1 CMO MODULE LABEL

The barcode nameplate is pasted on each module as illustration, and its definitions are as following explanation.



- (a) Model Name: V296W1-L11
- (b) Revision: Rev. XX, for example: A0, A1... B1, B2... or C1, C2...etc.
- (c) Serial ID: XXXXXXXXYMDLNNNN

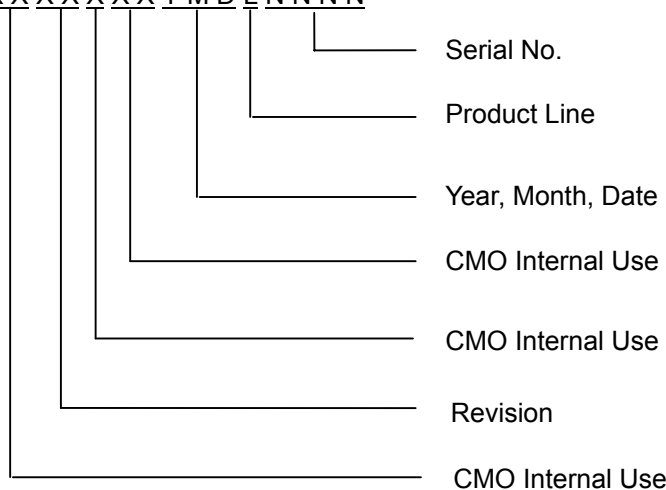

www.DataSheet4U.com

Serial ID includes the information as below:

- (a) Manufactured Date: Year: 1~9, for 2000~2009
 Month: 1~9, A~C, for Jan. ~ Dec.
 Day: 1~9, A~Y, for 1st to 31st, exclude I, O, and U.
- (b) Revision Code: Cover all the change
- (c) Serial No.: Manufacturing sequence of product
- (d) Product Line: 1 -> Line1, 2 -> Line 2, ...etc.

10. PRECAUTIONS

10.1 ASSEMBLY AND HANDLING PRECAUTIONS

- (1) Do not apply rough force such as bending or twisting to the module during assembly.
- (2) It is recommended to assemble or to install a module into the user's system in clean working areas. The dust and oil may cause electrical short or worsen the polarizer.
- (3) Do not apply pressure or impulse to the module to prevent the damage of LCD panel and Backlight.
- (4) Always follow the correct power-on sequence when the LCD module is turned on. This can prevent the damage and latch-up of the CMOS LSI chips.
- (5) Do not plug in or pull out the I/F connector while the module is in operation.
- (6) Do not disassemble the module.
- (7) Use a soft dry cloth without chemicals for cleaning, because the surface of polarizer is very soft and easily scratched.
- (8) Moisture can easily penetrate into LCD module and may cause the damage during operation.
- (9) High temperature or humidity may deteriorate the performance of LCD module. Please store LCD modules in the specified storage conditions.
- (10) When ambient temperature is lower than 10°C, the display quality might be reduced. For example, the response time will become slow, and the starting voltage of CCFL will be higher than that of room temperature.

10.2 SAFETY PRECAUTIONS

- (1) The startup voltage of a Backlight is approximately 1000 Volts. It may cause an electrical shock while assembling with the inverter. Do not disassemble the module or insert anything into the Backlight unit.
- (2) If the liquid crystal material leaks from the panel, it should be kept away from the eyes or mouth. In case of contact with hands, skin or clothes, it has to be washed away thoroughly with soap.
- (3) After the module's end of life, it is not harmful in case of normal operation and storage.

11. MECHANICAL CHARACTERISTICS

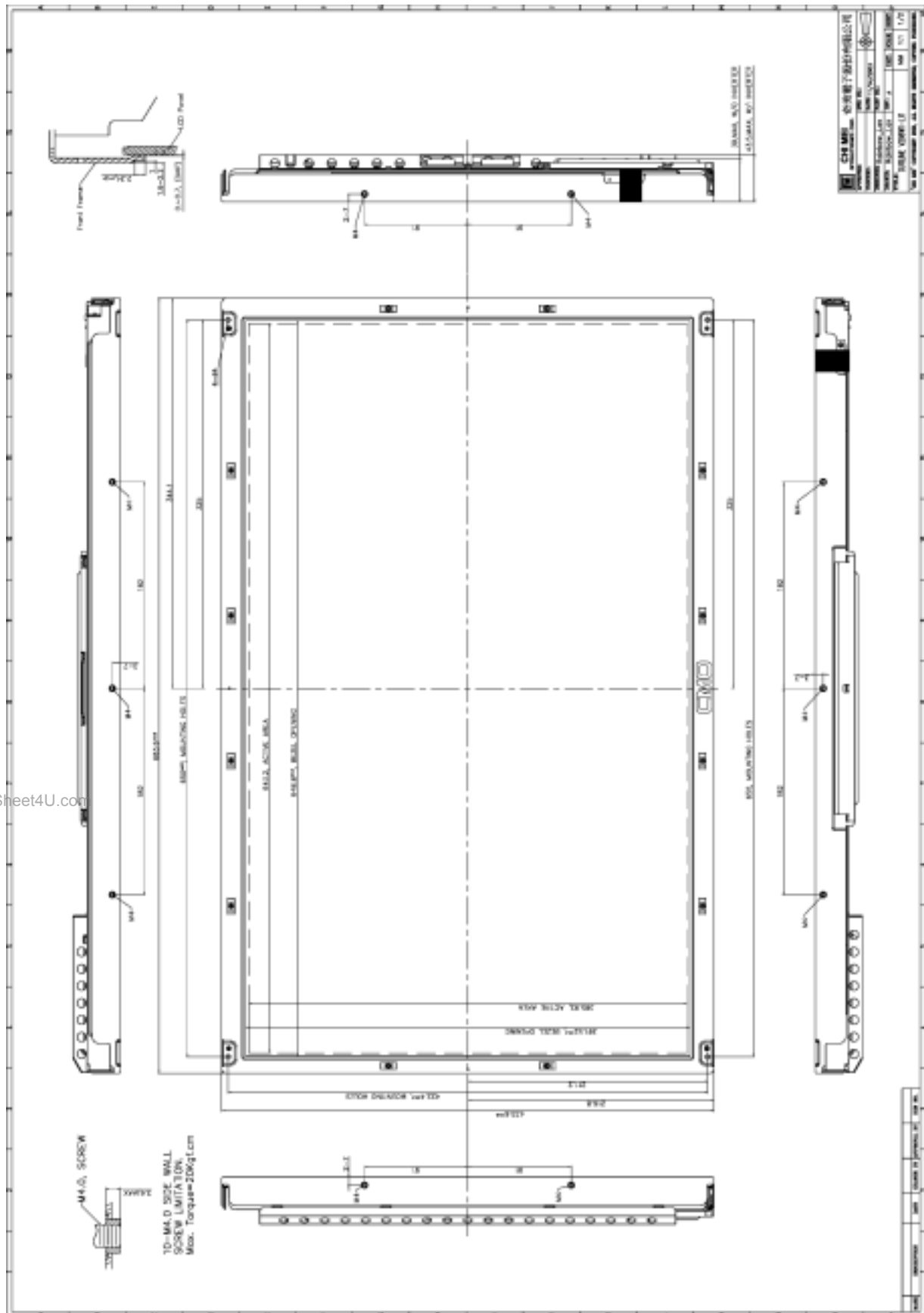

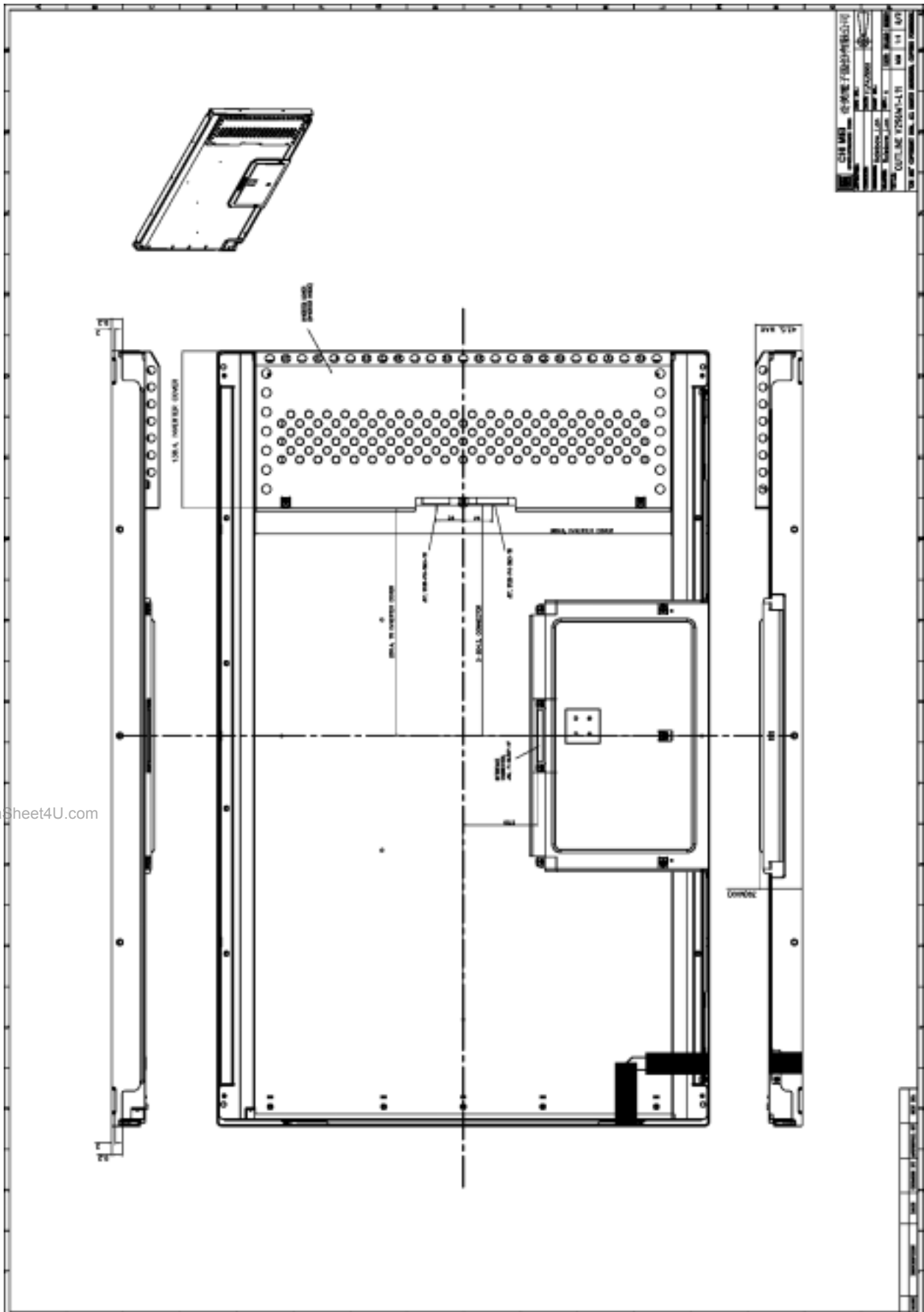

www.DataSheet4U.com

www.DataSheet4U.com

