

TFT LCD Approval Specification

MODEL NO.: V296W1 - L17

Customer: _____ Approved by: _____ Note:
--

LCD TV Head Division	
Director	郭振隆

Liquid Crystal Display Division			
QRA Dept.	TDDI	DDII	DDI
Approval	Approval	Approval	Approval
陳永一	李汪洋	鈴木優	林文聰

LCD TV Marketing and Product Management Dept.	
Project Manager	黃富瑞

- CONTENTS -

REVISION HISTORY	3
1. GENERAL DESCRIPTION	4
1.1 OVERVIEW	
1.2 FEATURES	
1.3 APPLICATION	
1.4 GENERAL SPECIFICATIONS	
1.5 MECHANICAL SPECIFICATIONS	
2. ABSOLUTE MAXIMUM RATINGS	5
2.1 ABSOLUTE RATINGS OF ENVIRONMENT	
2.2 ELECTRICAL ABSOLUTE RATINGS	
2.2.1 TFT LCD MODULE	
2.2.2 BACKLIGHT UNIT	
3. ELECTRICAL CHARACTERISTICS	6
3.1 TFT LCD MODULE	
3.2 BACKLIGHT UNIT	
4. BLOCK DIAGRAM	10
4.1 TFT LCD MODULE	
4.2 BACKLIGHT UNIT	
5. INPUT TERMINAL PIN ASSIGNMENT	11
5.1 TFT LCD MODULE	
5.2 BACKLIGHT UNIT	
5.3 BLOCK DIAGRAM OF INTERFACE	
5.4 LVDS INTERFACE	
5.5 COLOR DATA INPUT ASSIGNMENT	
6. INTERFACE TIMING	15
6.1 INPUT SIGNAL TIMING SPECIFICATIONS	
6.2 POWER ON/OFF SEQUENCE	
7. OPTICAL CHARACTERISTICS	17
7.1 TEST CONDITIONS	
7.2 OPTICAL SPECIFICATIONS	
8. PACKAGING	21
8.1 PACKING SPECIFICATIONS	
8.2 PACKING Method	
9. DEFINITION OF LABELS	23
10. PRECAUTIONS	24
10.1 ASSEMBLY AND HANDLING PRECAUTIONS	
10.2 SAFETY PRECAUTIONS	
11. MECHANICAL CHARACTERISTICS	25

REVISION HISTORY

Version	Date	Page (New)	Section	Description
Ver 2.0	Feb.20,'04	All	All	Approval Specification was first issued.

1. GENERAL DESCRIPTION

1.1 OVERVIEW

V296W1- L17 is a 30" TFT Liquid Crystal Display module with 16-CCFL Backlight unit and 1ch-LVDS interface. This module supports 1280 x 768 WXGA format and can display true 16.7M colors (8-bit/color). The inverter module for backlight is built-in.

1.2 FEATURES

- Ultra wide viewing angle – Super MVA technology
- High brightness (550 nits)
- High contrast ratio (600:1)
- Fast response time
- High color saturation NTSC 75%
- WXGA (1280 x 768 pixels) resolution
- DE (Data Enable) only mode
- LVDS (Low Voltage Differential Signaling) interface

1.3 APPLICATION

- TFT LCD TVs

1.4 GENERAL SPECIFICATIONS

Item	Specification	Unit	Note
Active Area	643.2(H) x 385.92 (V) (29.53" diagonal)	mm	(1)
Bezel Opening Area	648.8 (H) x 391.52 (V)	mm	
Driver Element	a-si TFT active matrix	-	-
Pixel Number	1280 x R.G.B. x 768	pixel	-
Pixel Pitch (Sub Pixel)	0.1675 (H) x 0.5025 (V)	mm	-
Pixel Arrangement	RGB vertical stripe	-	-
Display Colors	16.7M	color	-
Display Operation Mode	Transmissive mode / Normally black	-	-
Surface Treatment	Anti-glare with anti-reflective coating Hard coating (2H), Haze : 40% Reflection rate : < 2%	-	-

1.5 MECHANICAL SPECIFICATIONS

Item	Min.	Typ.	Max.	Unit	Note
Module Size	Horizontal(H)	683.6		mm	(1), (2)
	Vertical(V)	433.6		mm	
	Depth(D)	-		43	
Weight	-	5500		g	-

Note (1) Please refer to the attached drawings for more information of front and back outline dimensions.

Note (2) Module Depth does not include connectors.

2. ABSOLUTE MAXIMUM RATINGS

2.1 ABSOLUTE RATINGS OF ENVIRONMENT

Item	Symbol	Value		Unit	Note
		Min.	Max.		
Storage Temperature	T _{ST}	-20	+60	°C	(1)
Operating Ambient Temperature	T _{OP}	0	+50	°C	(1), (2)
Shock (Non-Operating)	S _{NOF}	-	100	G	(3), (5)
Vibration (Non-Operating)	V _{NOF}	-	1.0	G	(4), (5)

Note (1) Temperature and relative humidity range is shown in the figure below.

- (a) 90 %RH Max. ($T_a \leq 40$ °C).
- (b) Wet-bulb temperature should be 39 °C Max. ($T_a > 40$ °C).
- (c) No condensation.

Note (2) The maximum operating temperature is based on the test condition that the surface temperature of display area is less than or equal to 60 °C with LCD module alone in a temperature controlled chamber. Thermal management should be considered in your product design to prevent the surface temperature of display area from being over 60 °C. The range of operating temperature may degrade in case of improper thermal management in your product design.

Note (3) 2 ms, half sine wave, 1 time for $\pm X$, $\pm Y$, $\pm Z$.

Note (4) 10 ~ 500 Hz, 10 min, 1 time each X, Y, Z.

Note (5) At testing Vibration and Shock, the fixture in holding the module has to be hard and rigid enough so that the module would not be twisted or bent by the fixture.

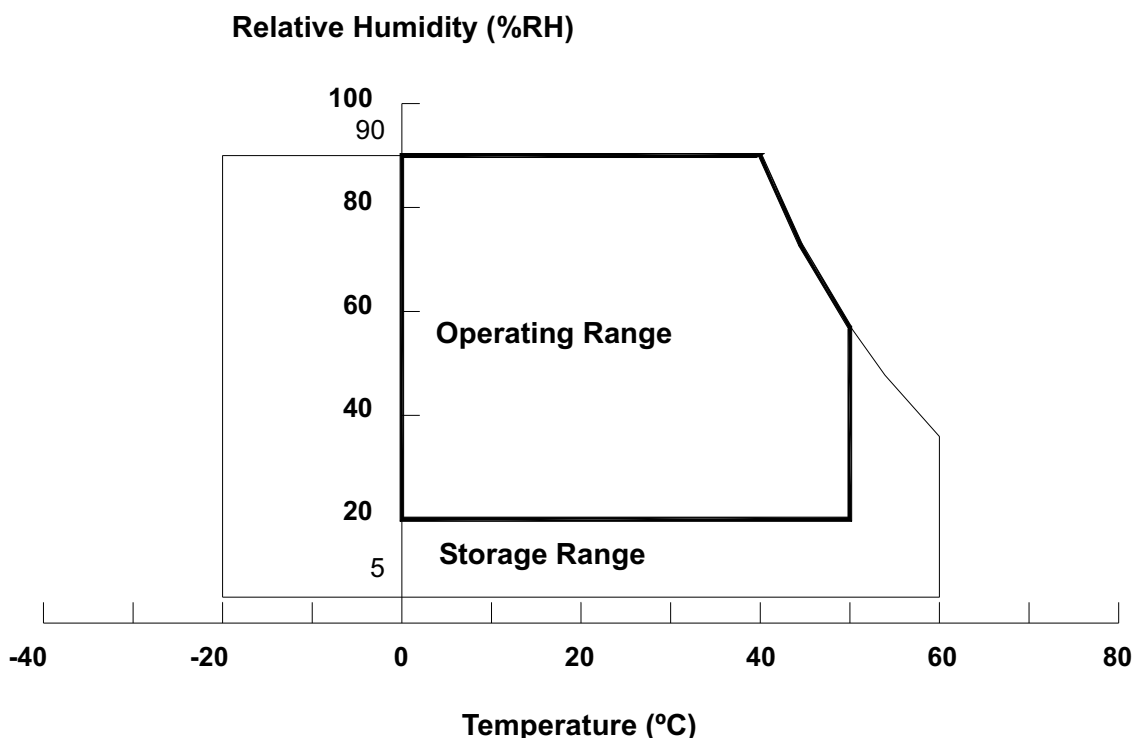

2.2 ELECTRICAL ABSOLUTE RATINGS

2.2.1 TFT LCD MODULE

Item	Symbol	Value		Unit	Note
		Min.	Max.		
Power Supply Voltage	V _{CC}	-0.3	+6.0	V	(1)
Logic Input Voltage	V _{IN}	-0.3	4.3	V	

2.2.2 BACKLIGHT UNIT

Item	Symbol	Value		Unit	Note
		Min.	Max.		
Lamp Voltage	V _L	-	2.5K	V _{RMS}	(1), (2), I _L = 6.0 mA
Lamp Current	I _L	-	6.5	mA _{RMS}	(1), (2)
Lamp Frequency	F _L	-	80	KHz	

Note (1) Permanent damage to the device may occur if maximum values are exceeded. Function operation should be restricted to the conditions described under Normal Operating Conditions.

Note (2) Specified values are for lamp (Refer to 3.2 for further information).

3. ELECTRICAL CHARACTERISTICS

3.1 TFT LCD MODULE

T_a = 25 ± 2 °C

Parameter	Symbol	Value			Unit	Note
		Min.	Typ.	Max.		
Power Supply Voltage	V _{CC}	4.5	5.0	5.5	V	-
Ripple Voltage	V _{RP}	-	-	200	mV	-
Rush Current	I _{RUSH}	-	-	3.0	A	(2)
Power Supply Current	White	-	1.5	-	A	(3)a
	Black	-	0.8	-	A	(3)b
	Vertical Stripe	-	1.2	-	A	(3)c
LVDS differential input high threshold voltage	V _{TH}	-	-	+100	mV	
LVDS differential input low threshold voltage	V _{TL}	-100	-	-	mV	
LVDS common input voltage	V _{IC}	1.125	1.25	1.375	V	
Terminating Resistor	R _T	-	100	-	ohm	

Note (1) The module should be always operated within above ranges.

Note (2) Measurement Conditions:

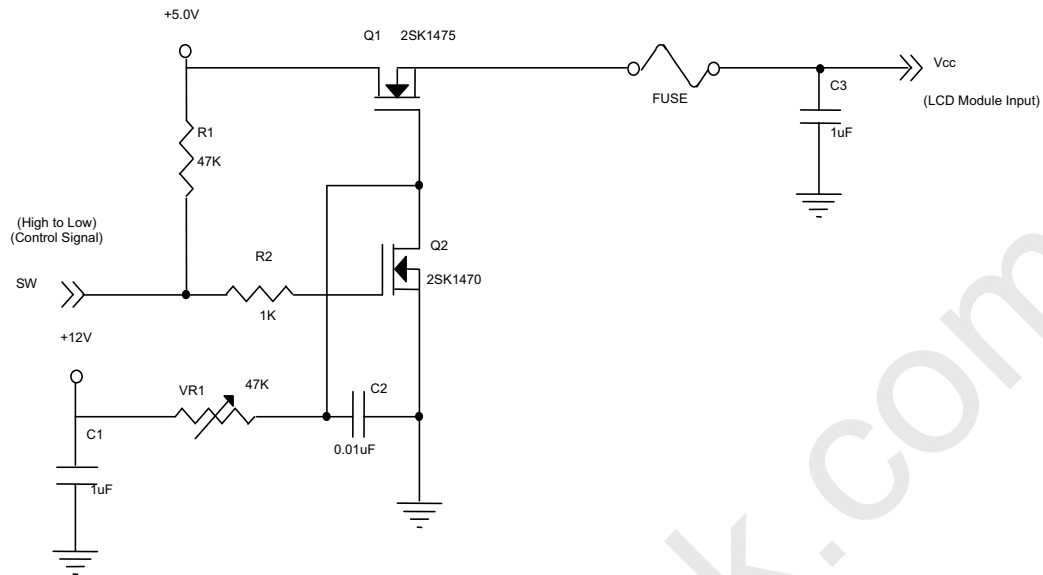

Vcc rising time is 470 μ s

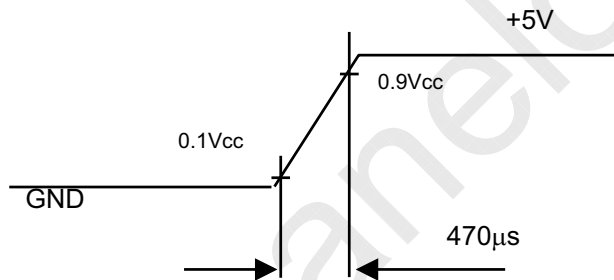

Note (3) The specified power supply current is under the conditions at $V_{cc} = 5\text{ V}$, $T_a = 25 \pm 2\text{ }^\circ\text{C}$, $f_v = 60\text{ Hz}$, whereas a power dissipation check pattern below is displayed.

a. White Pattern

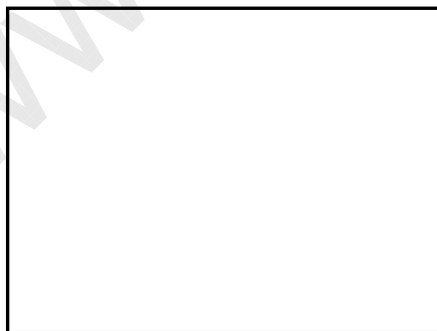

Active Area

b. Black Pattern

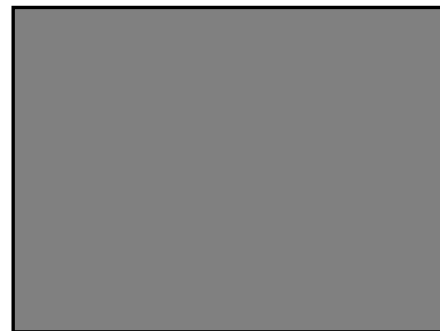

Active Area

c. Vertical Stripe Pattern

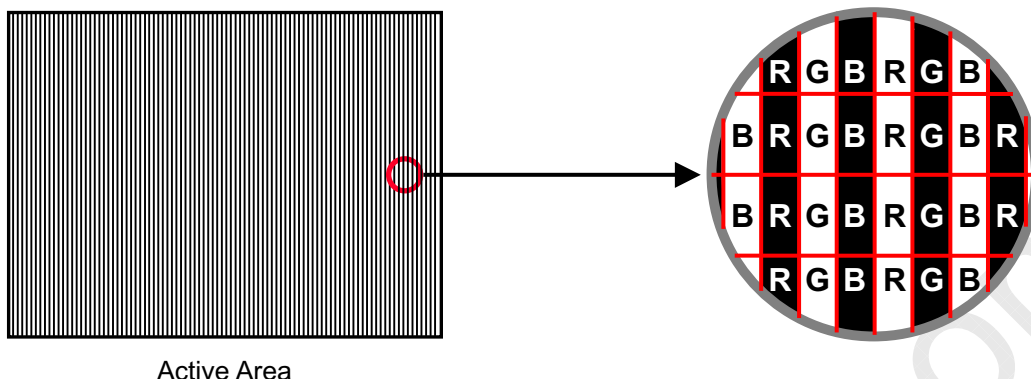

3.2 BACKLIGHT UNIT

Ta = 25 ± 2 °C

Parameter	Symbol	Value			Unit	Note
		Min.	Typ.	Max.		
Lamp Input Voltage	V _L	1053	1170	1287	V _{RMS}	I _L = (4.5) mA
Lamp Current	I _L	4.2	4.5	4.8	mA _{RMS}	(1)
Lamp Turn On Voltage	V _s	1560	-	3000	V _{RMS}	(2), Ta = 25 °C
		1870	-	3000	V _{RMS}	(2), Ta = 0 °C
Operating Frequency	F _L	57	62	67	KHz	(3)
Lamp Life Time	L _{BL}	50K	-	-	Hrs	(5)
Power Consumption	P _L	-	105	-	W	(4), I _L = (4.5) mA

Note (1) Lamp current is measured by utilizing high frequency current meters as shown below:

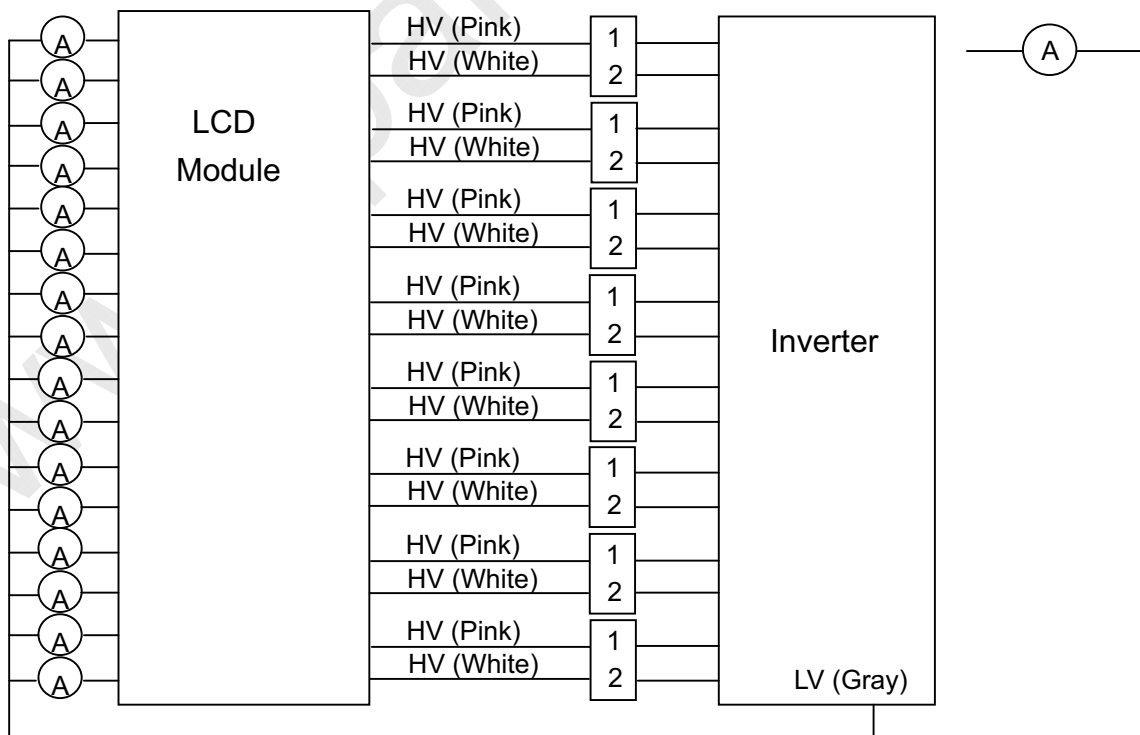

- Note (2) The voltage shown above should be applied to the lamp for more than 1 second after startup. Otherwise the lamp may not be turned on.
- Note (3) The lamp frequency may produce interference with horizontal synchronous frequency from the display, and this may cause line flow on the display. In order to avoid interference, the lamp frequency should be detached from the horizontal synchronous frequency and its harmonics as far as possible.
- Note (4) $P_L = (\sum I_{lamp1-lamp16} I_L \times V_L) / 0.8$, P_L is based on the inverter efficiency, which is 80%.
- Note (5) The lifetime of a lamp is defined as the time in which it continues to operate under the condition $T_a = 25 \pm 2^\circ\text{C}$ and $I_L = (4.2) \sim (4.8)$ mAmps until one of the following events occurs:
- (a) When the brightness becomes equal or less than 50% of its original value.
 - (b) When the effective discharge length becomes equal or lower than 80% of its original value.
(Effective discharge length is defined as an area that has equal or more than 70% brightness compared to the brightness at the center point.)
- Note (6) The waveform of the voltage output of inverter must be area-symmetric and the design of the inverter must have specifications for the modularized lamp. The performance of the Backlight, such as lifetime or brightness, is greatly influenced by the characteristics of the DC-AC inverter for the lamp. All the parameters of an inverter should be carefully designed to avoid producing too much current leakage from high voltage output of the inverter. When designing or ordering the inverter please make sure that a poor lighting caused by the mismatch of the Backlight and the inverter (miss-lighting, flicker, etc.) never occurs. If the above situation is confirmed, the module should be operated in the same manners when it is installed in your instrument.

4. BLOCK DIAGRAM

4.1 TFT LCD MODULE

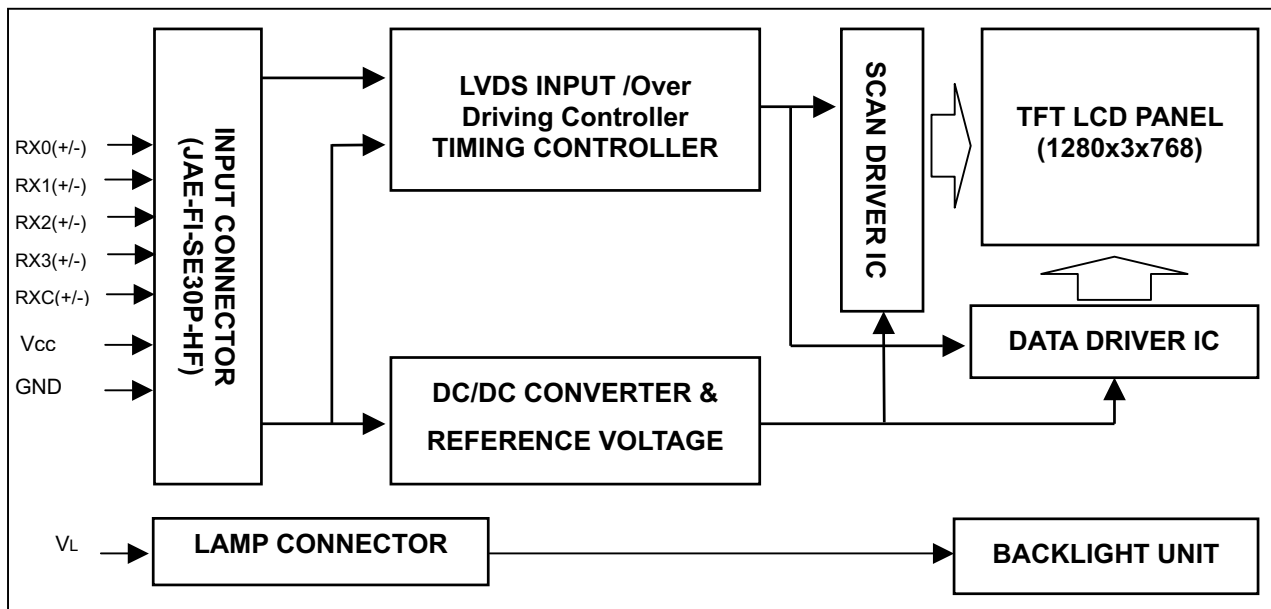

4.2 BACKLIGHT UNIT

Lamp connector

HV : BHR-03-VS-1(JST) *8

LV : ZHR-2 (JST) *1

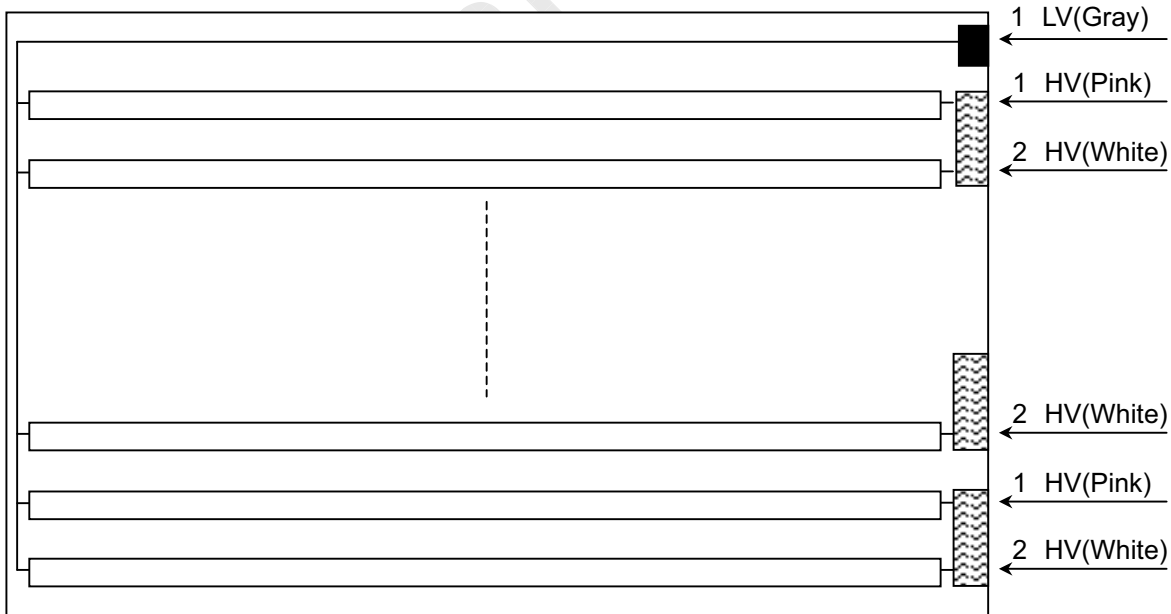

5. INPUT TERMINAL PIN ASSIGNMENT

5.1 TFT LCD MODULE

Pin	Name	Description
1	NC	No Connection
2	NC	No Connection
3	NC	No Connection
4	NC	No Connection
5	NC	No Connection
6	NC	No Connection
7	NC	No Connection
8	GND	Ground
9	RX3+	Positive LVDS differential data input. Channel 3
10	RX3-	Negative LVDS differential data input. Channel 3
11	RXCLK+	Positive LVDS differential clock input.
12	RXCLK-	Negative LVDS differential clock input.
13	GND	Ground
14	GND	Ground
15	RX2+	Positive LVDS differential data input. Channel 2
16	RX2-	Negative LVDS differential data input. Channel 2
17	RX1+	Positive LVDS differential data input. Channel 1
18	RX1-	Negative LVDS differential data input. Channel 1
19	RX0+	Positive LVDS differential data input. Channel 0
20	RX0-	Negative LVDS differential data input. Channel 0
21	GND	Ground
22	GND	Ground
23	GND	Ground
24	GND	Ground
25	GND	Ground
26	VCC	+5.0V power supply
27	VCC	+5.0V power supply
28	VCC	+5.0V power supply
29	VCC	+5.0V power supply
30	VCC	+5.0V power supply

Note (1) Connector Part No.: FI-SE30P-HF (JAE)

Note (2) The first pixel is even.

5.2 BACKLIGHT UNIT

Pin	Symbol	Description	Color
1	HV	High Voltage	Pink
2	HV	High Voltage	White

Note (1) Connector Part No.: BHR-03VS-1 (JST) or equivalent

Note (2) User's connector Part No.: SM02(8.0)B-BHS-1TB (JST) or equivalent

Pin	Symbol	Description	Color
1	LV	Low Voltage	Gray
2	NC	No Connection	

Note (1) Connector Part No.: ZHR-2 (JST) or equivalent

Note (2) User's connector Part No.: S2B-ZR-SM3A-TF (JST) or equivalent

5.3 BLOCK DIAGRAM OF INTERFACE

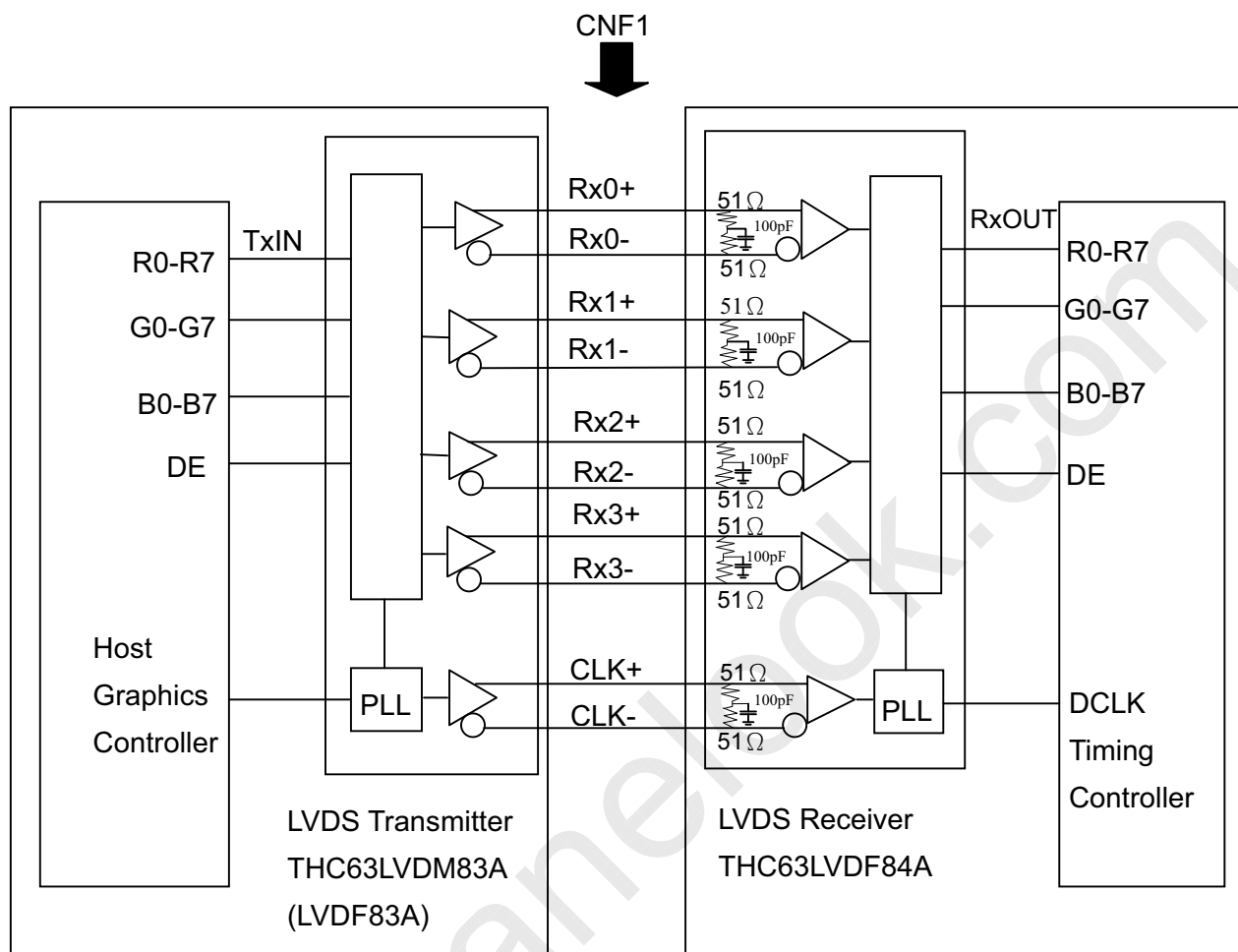

R0~R7 : Pixel R Data ,
 G0~G7 : Pixel G Data ,
 B0~B7 : Pixel B Data ,
 DE : Display timing signal

Notes: 1) The system must have the transmitter to drive the module.

2) LVDS cable impedance shall be 50 ohms per signal line or about 100 ohms per twist-pair line when it is used differentially.

5.4 LVDS INTERFACE

	SIGNAL	TRANSMITTER THC63LVDM83A		INTERFACE CONNECTOR		RECEIVER THC63LVDF84A		TFT CONTROL
		PIN	INPUT	Host	TFT-LCD	PIN	OUTPUT	INPUT
24bit	R0	51	TxIN0	TA OUT0+	Rx 0+	27	Rx OUT0	R0
	R1	52	TxIN1			29	Rx OUT1	R1
	R2	54	TxIN2			30	Rx OUT2	R2
	R3	55	TxIN3			32	Rx OUT3	R3
	R4	56	TxIN4	TA OUT0-	Rx 0-	33	Rx OUT4	R4
	R5	3	TxIN6			35	Rx OUT6	R5
	G0	4	TxIN7			37	Rx OUT7	G0
	G1	6	TxIN8			38	Rx OUT8	G1
	G2	7	TxIN9	TA OUT1+	Rx 1+	39	Rx OUT9	G2
	G3	11	TxIN12			43	Rx OUT12	G3
	G4	12	TxIN13			45	Rx OUT13	G4
	G5	14	TxIN14			46	Rx OUT14	G5
	B0	15	TxIN15	TA OUT1-	Rx 1-	47	Rx OUT15	B0
	B1	19	TxIN18			51	Rx OUT18	B1
	B2	20	TxIN19			53	Rx OUT19	B2
	B3	22	TxIN20			54	Rx OUT20	B3
	B4	23	TxIN21	TA OUT2+	Rx 2+	55	Rx OUT21	B4
	B5	24	TxIN22			1	Rx OUT22	B5
	DE	30	TxIN26			6	Rx OUT26	DE
	R6	50	TxIN27			7	Rx OUT27	R6
	R7	2	TxIN5	TA OUT2-	Rx 2-	34	Rx OUT5	R7
	G6	8	TxIN10			41	Rx OUT10	G6
	G7	10	TxIN11			42	Rx OUT11	G7
	B6	16	TxIN16			49	Rx OUT16	B6
	B7	18	TxIN17	TA OUT3+	Rx 3+	50	Rx OUT17	B7
	RSVD 1	25	TxIN23			2	Rx OUT23	Not connect
	RSVD 2	27	TxIN24			3	Rx OUT24	Not connect
	RSVD 3	28	TxIN25			5	Rx OUT25	Not connect
	DCLK	31	TxCLK IN	TxCLK OUT+ TxCLK OUT-	RxCLK IN+ RxCLK IN-	26	RxCLK OUT	DCLK

R0~R7: Pixel R Data (7; MSB, 0; LSB)

G0~G7: Pixel G Data (7; MSB, 0; LSB)

B0~B7: Pixel B Data (7; MSB, 0; LSB)

DE : Display timing signal

Notes: (1)RSVD(reserved)pins on the transmitter shall be "H" or "L".



5.5 COLOR DATA INPUT ASSIGNMENT

The brightness of each primary color (red, green and blue) is based on the 8-bit gray scale data input for the color. The higher the binary input, the brighter the color. The table below provides the assignment of color versus data input.

Color		Data Signal																							
		Red								Green								Blue							
		R7	R6	R5	R4	R3	R2	R1	R0	R7	R6	G5	G4	G3	G2	G1	G0	R7	R6	B5	B4	B3	B2	B1	B0
Basic Colors	Black	0	0	0	0	0	0	0	0	0	0	0	0	0	0	0	0	0	0	0	0	0	0	0	0
	Red	1	1	1	1	1	1	1	1	0	0	0	0	0	0	0	0	0	0	0	0	0	0	0	0
	Green	0	0	0	0	0	0	0	0	1	1	1	1	1	1	1	1	0	0	0	0	0	0	0	0
	Blue	0	0	0	0	0	0	0	0	0	0	0	0	0	0	0	0	1	1	1	1	1	1	1	1
	Cyan	0	0	0	0	0	0	0	0	1	1	1	1	1	1	1	1	1	1	1	1	1	1	1	1
	Magenta	1	1	1	1	1	1	1	1	0	0	0	0	0	0	0	0	1	1	1	1	1	1	1	1
	Yellow	1	1	1	1	1	1	1	1	1	1	1	1	1	1	1	1	0	0	0	0	0	0	0	0
	White	1	1	1	1	1	1	1	1	1	1	1	1	1	1	1	1	1	1	1	1	1	1	1	1
Gray Scale Of Red	Red(0) / Dark	0	0	0	0	0	0	0	0	0	0	0	0	0	0	0	0	0	0	0	0	0	0	0	
	Red(1)	0	0	0	0	0	0	0	1	0	0	0	0	0	0	0	0	0	0	0	0	0	0	0	
	Red(2)	0	0	0	0	0	0	1	0	0	0	0	0	0	0	0	0	0	0	0	0	0	0	0	
	⋮	⋮	⋮	⋮	⋮	⋮	⋮	⋮	⋮	⋮	⋮	⋮	⋮	⋮	⋮	⋮	⋮	⋮	⋮	⋮	⋮	⋮	⋮	⋮	
	⋮	⋮	⋮	⋮	⋮	⋮	⋮	⋮	⋮	⋮	⋮	⋮	⋮	⋮	⋮	⋮	⋮	⋮	⋮	⋮	⋮	⋮	⋮	⋮	
	⋮	⋮	⋮	⋮	⋮	⋮	⋮	⋮	⋮	⋮	⋮	⋮	⋮	⋮	⋮	⋮	⋮	⋮	⋮	⋮	⋮	⋮	⋮	⋮	
	Red(253)	1	1	1	1	1	1	0	1	0	0	0	0	0	0	0	0	0	0	0	0	0	0	0	
	Red(254)	1	1	1	1	1	1	1	0	0	0	0	0	0	0	0	0	0	0	0	0	0	0	0	
Red(255)	1	1	1	1	1	1	1	1	0	0	0	0	0	0	0	0	0	0	0	0	0	0	0		
Gray Scale Of Green	Green(0) / Dark	0	0	0	0	0	0	0	0	0	0	0	0	0	0	0	0	0	0	0	0	0	0	0	
	Green(1)	0	0	0	0	0	0	0	0	0	0	0	0	0	0	1	0	0	0	0	0	0	0	0	
	Green(2)	0	0	0	0	0	0	0	0	0	0	0	0	0	1	0	0	0	0	0	0	0	0	0	
	⋮	⋮	⋮	⋮	⋮	⋮	⋮	⋮	⋮	⋮	⋮	⋮	⋮	⋮	⋮	⋮	⋮	⋮	⋮	⋮	⋮	⋮	⋮	⋮	
	⋮	⋮	⋮	⋮	⋮	⋮	⋮	⋮	⋮	⋮	⋮	⋮	⋮	⋮	⋮	⋮	⋮	⋮	⋮	⋮	⋮	⋮	⋮	⋮	
	⋮	⋮	⋮	⋮	⋮	⋮	⋮	⋮	⋮	⋮	⋮	⋮	⋮	⋮	⋮	⋮	⋮	⋮	⋮	⋮	⋮	⋮	⋮	⋮	
	Green(253)	0	0	0	0	0	0	0	0	1	1	1	1	1	1	0	1	0	0	0	0	0	0	0	
	Green(254)	0	0	0	0	0	0	0	0	1	1	1	1	1	1	1	0	0	0	0	0	0	0	0	
Green(255)	0	0	0	0	0	0	0	0	1	1	1	1	1	1	1	1	0	0	0	0	0	0	0		
Gray Scale Of Blue	Blue(0) / Dark	0	0	0	0	0	0	0	0	0	0	0	0	0	0	0	0	0	0	0	0	0	0	0	
	Blue(1)	0	0	0	0	0	0	0	0	0	0	0	0	0	0	0	0	0	0	0	0	0	0	1	
	Blue(2)	0	0	0	0	0	0	0	0	0	0	0	0	0	0	0	0	0	0	0	0	0	0	1	
	⋮	⋮	⋮	⋮	⋮	⋮	⋮	⋮	⋮	⋮	⋮	⋮	⋮	⋮	⋮	⋮	⋮	⋮	⋮	⋮	⋮	⋮	⋮	⋮	
	⋮	⋮	⋮	⋮	⋮	⋮	⋮	⋮	⋮	⋮	⋮	⋮	⋮	⋮	⋮	⋮	⋮	⋮	⋮	⋮	⋮	⋮	⋮	⋮	
	⋮	⋮	⋮	⋮	⋮	⋮	⋮	⋮	⋮	⋮	⋮	⋮	⋮	⋮	⋮	⋮	⋮	⋮	⋮	⋮	⋮	⋮	⋮	⋮	
	Blue(253)	0	0	0	0	0	0	0	0	0	0	0	0	0	0	0	1	1	1	1	1	1	1	0	
	Blue(254)	0	0	0	0	0	0	0	0	0	0	0	0	0	0	0	1	1	1	1	1	1	1	0	
Blue(255)	0	0	0	0	0	0	0	0	0	0	0	0	0	0	0	1	1	1	1	1	1	1	1		

Note (1) 0: Low Level Voltage, 1: High Level Voltage

6. INTERFACE TIMING

6.1 INPUT SIGNAL TIMING SPECIFICATIONS

The input signal timing specifications are shown as the following table and timing diagram.

Signal	Item	Symbol	Min.	Typ.	Max.	Unit	Note
Clock	Frequency	1/Tc	62	81	82	MHZ	-
Vertical Active Display Term	Frame Rate	Fr	-	60	64	Hz	$T_v = T_{vd} + T_{vb}$
	Total	T_v	780	806	850	Th	-
	Display	T_{vd}	768	768	768	Th	-
	Blank	T_{vb}	12	38	82	Th	-
Horizontal Active Display Term	Total	T_h	1450	1688	2000	Tc	$T_h = T_{hd} + T_{hb}$
	Display	T_{hd}	1280	1280	1280	Tc	-
	Blank	T_{hb}	170	408	720	Tc	-

Note: Because of this module is operated by DE only mode, Hsync and Vsync input signals should be set to low logic level or ground. Otherwise, this module would operate abnormally.

INPUT SIGNAL TIMING DIAGRAM

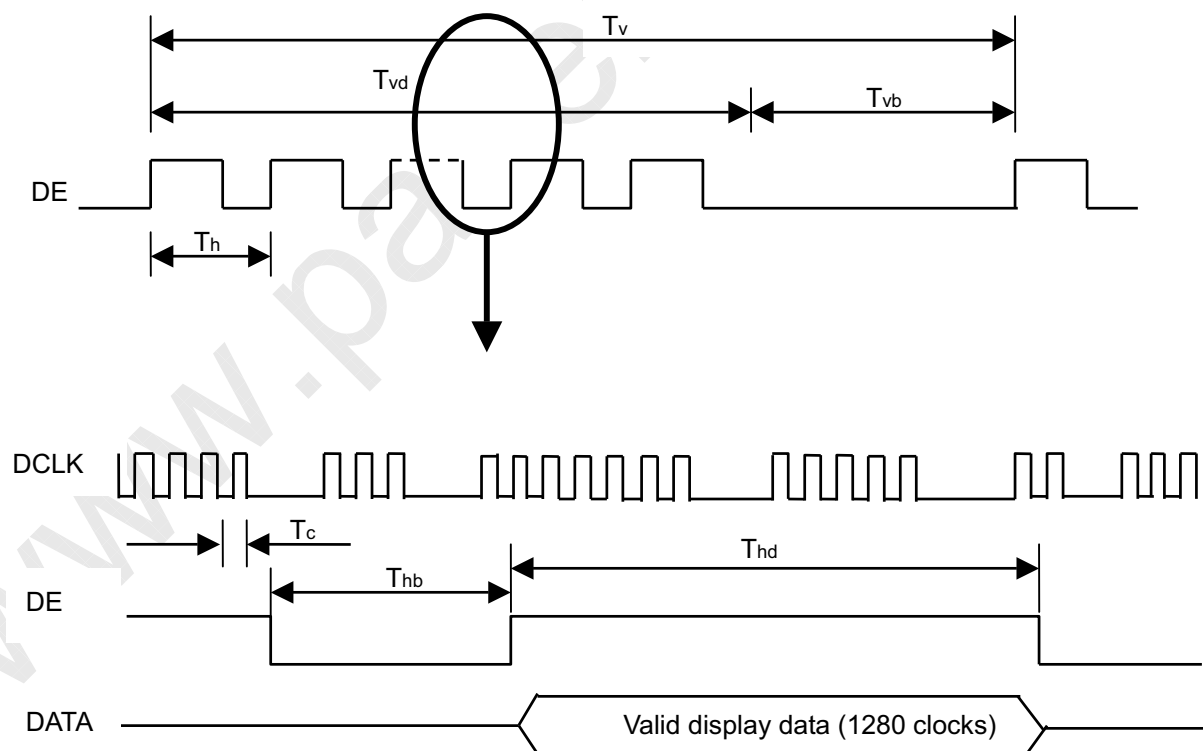

6.2 POWER ON/OFF SEQUENCE

To prevent a latch-up or DC operation of LCD module, the power on/off sequence should be as the diagram below.

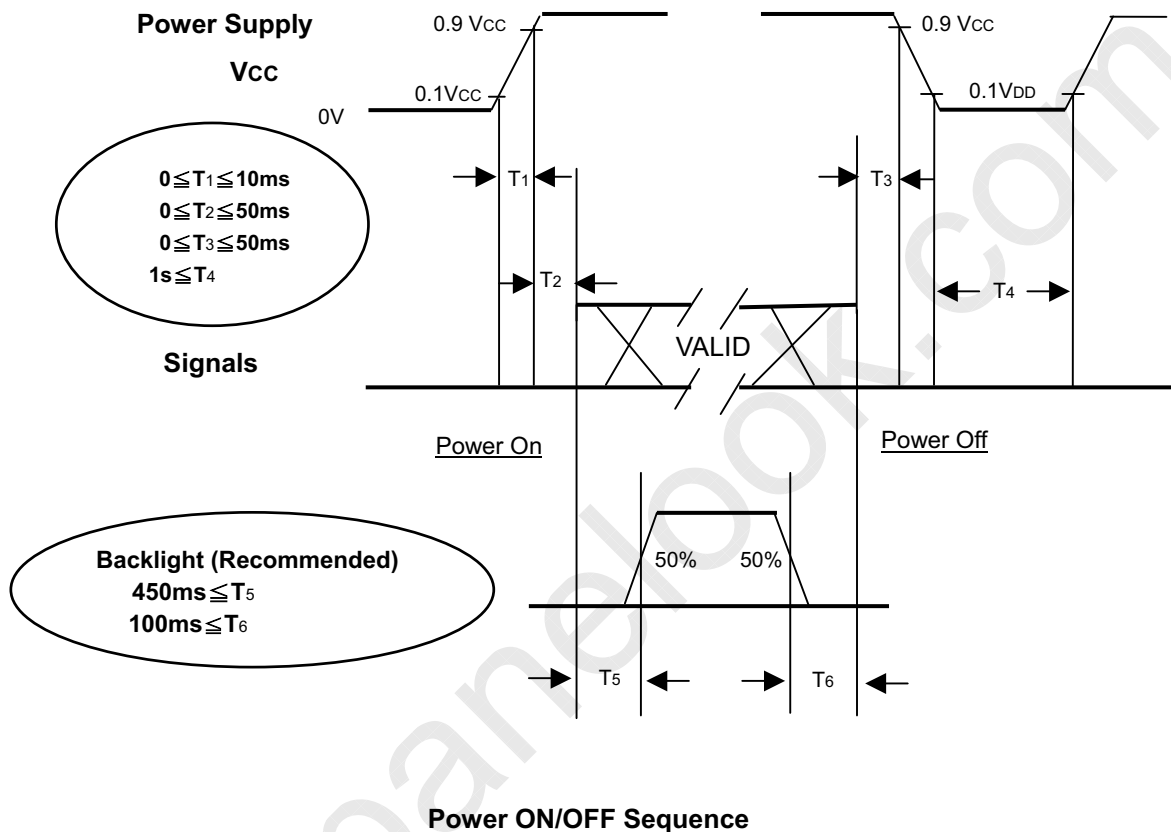

Note.

- (1) The supply voltage of the external system for the module input should be the same as the definition of Vcc.
- (2) Apply the lamp voltage within the LCD operation range. When the backlight turns on before the LCD operation of the LCD turns off before the backlight turns off, the display may momentarily become abnormal screen.
- (3) In case of VCC = off level, please keep the level of input signals on the low or keep a high impedance.
- (4) T4 should be measured after the module has been fully discharged between power off and on period.
- (5) Interface signal shall not be kept at high impedance when the power is on.

7. OPTICAL CHARACTERISTICS

7.1 TEST CONDITIONS

Item	Symbol	Value	Unit
Ambient Temperature	T _a	25±2	°C
Ambient Humidity	H _a	50±10	%RH
Supply Voltage	V _{CC}	5.0	V
Input Signal	According to typical value in "3. ELECTRICAL CHARACTERISTICS"		
Inverter Current	I _L	4.5	mA
Inverter Driving Frequency	F _L	55	KHz
Inverter		--	

7.2 OPTICAL SPECIFICATIONS

The relative measurement methods of optical characteristics are shown in 7.2. The following items should be measured under the test conditions described in 7.1 and stable environment shown in Note (7).

Item		Symbol	Condition	Min.	Typ.	Max.	Unit	Note	
Contrast Ratio		CR	$\theta_x=0^\circ, \theta_y=0^\circ$ Viewing Normal Angle	400	600	-	-	Note(2)	
Response Time		T _R		-	15	25	ms	Note(3)	
		T _F		-	10	20	ms		
		Gray to gray				16.6	25	ms	Note(4)
Center Luminance of White		L _C			450	550	-	cd/m ²	Note(5)
Average Luminance of White		L _{AVE}			400	450	-	cd/m ²	
White Variation		δW			-	-	1.3	-	Note(8)
Cross Talk		CT			-	-	4.0	%	Note(6)
Color Chromaticity	Red	R _x			0.614	0.644	0.674	-	9, 300K
		R _y			0.301	0.331	0.361	-	
	Green	G _x		0.240	0.270	0.300	-		
		G _y		0.574	0.604	0.634	-		
	Blue	B _x		0.112	0.142	0.172	-		
		B _y		0.044	0.074	0.114	-		
	White	W _x		0.255	0.285	0.315	-		
		W _y		0.263	0.293	0.323	-		
Color Gamut		CG		72	75		%	NTSC Ratio	
Viewing Angle	Horizontal	θ_{x+}	CR≥10	80	85	-	Deg.	Note(1) No gray scale inversion	
		θ_{x-}		80	85	-			
	Vertical	θ_{y+}		80	85	-			
		θ_{y-}		80	85	-			

Note (1) Definition of Viewing Angle (θ_x , θ_y):

Viewing angles are measured by EZ-Contrast 160R (Eldim)

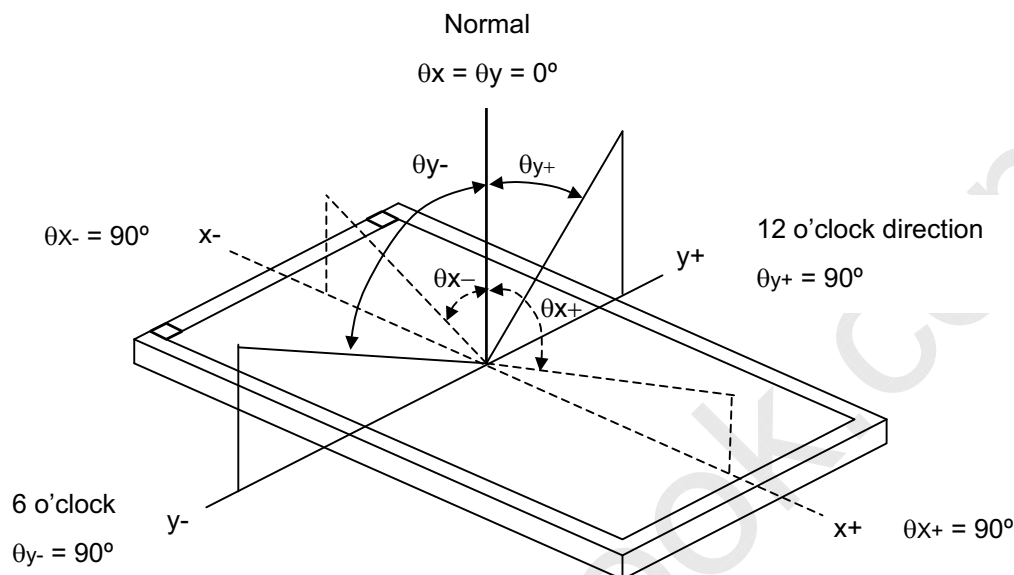

Note (2) Definition of Contrast Ratio (CR):

The contrast ratio can be calculated by the following expression.

$$\text{Contrast Ratio (CR)} = L_{255} / L_0$$

L₂₅₅: Luminance of gray level 255

L₀: Luminance of gray level 0

$$\text{CR} = \text{CR} (5)$$

CR (X) is corresponding to the Contrast Ratio of the point X at the figure in Note (8).

Note (3) Definition of Response Time (T_R , T_F):

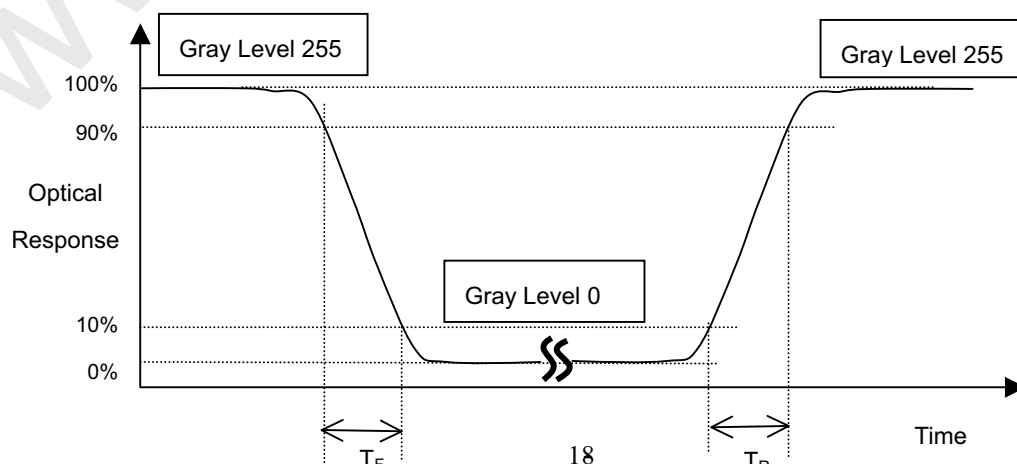

The information described in this technical specification is tentative and it is possible to be changed without prior notice. Please contact CMO's representative while your product design is based on this specification. **Version 2.0**

Note (4) Definition of Gray to Gray Switching Time:

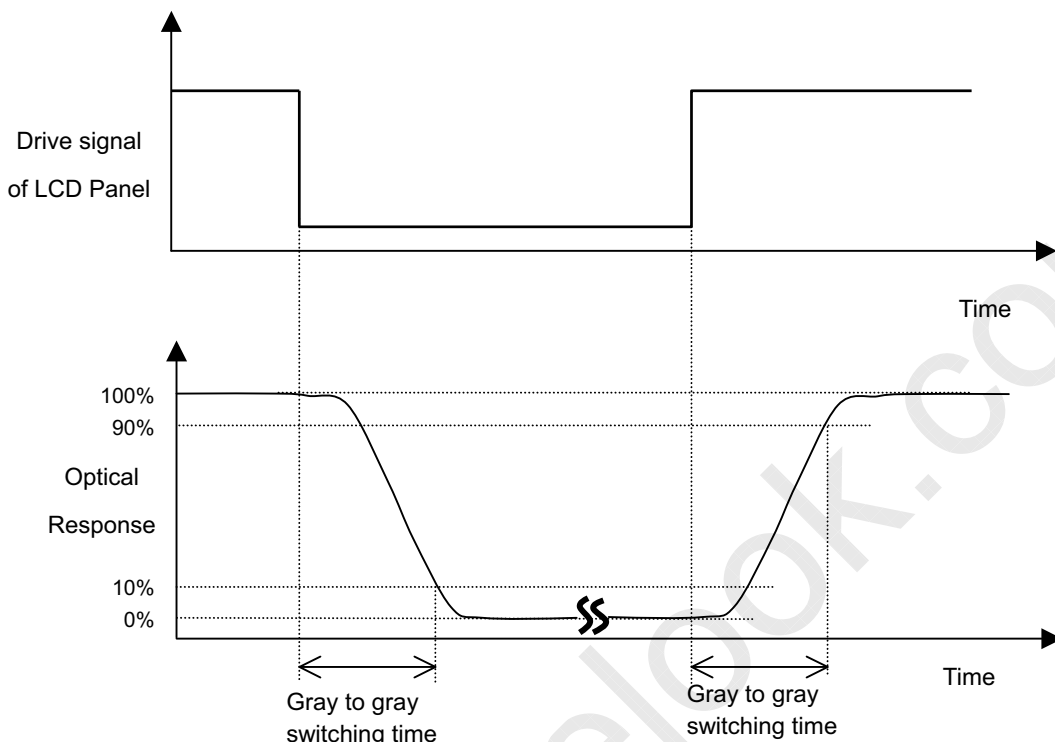

The driving signal means the signal of gray level 0, 63, 127, 191, 255.

Note (5) Definition of Luminance of White (L_C , L_{AVE}):

Measure the luminance of gray level 255 at center point and 5 points

$$L_C = L(5)$$

$$L_{AVE} = [L(1) + L(2) + L(3) + L(4) + L(5)] / 5$$

$L(x)$ is corresponding to the luminance of the point X at the figure in Note (8).

Note (6) Definition of Cross Talk (CT):

$$CT = |Y_B - Y_A| / Y_A \times 100 (\%)$$

Where:

Y_A = Luminance of measured location without gray level 0 pattern (cd/m^2)

Y_B = Luminance of measured location with gray level 0 pattern (cd/m^2)

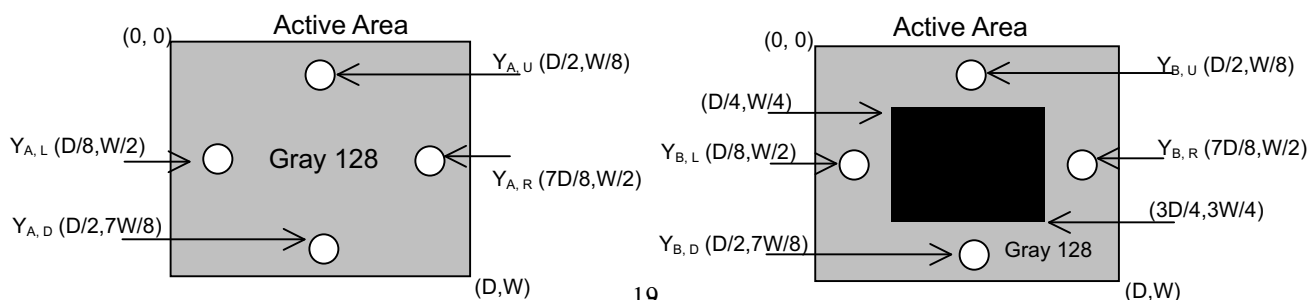

Note (7) Measurement Setup:

The LCD module should be stabilized at given temperature for 1 hour to avoid abrupt temperature change during measuring. In order to stabilize the luminance, the measurement should be executed after lighting Backlight for 1 hour in a windless room.

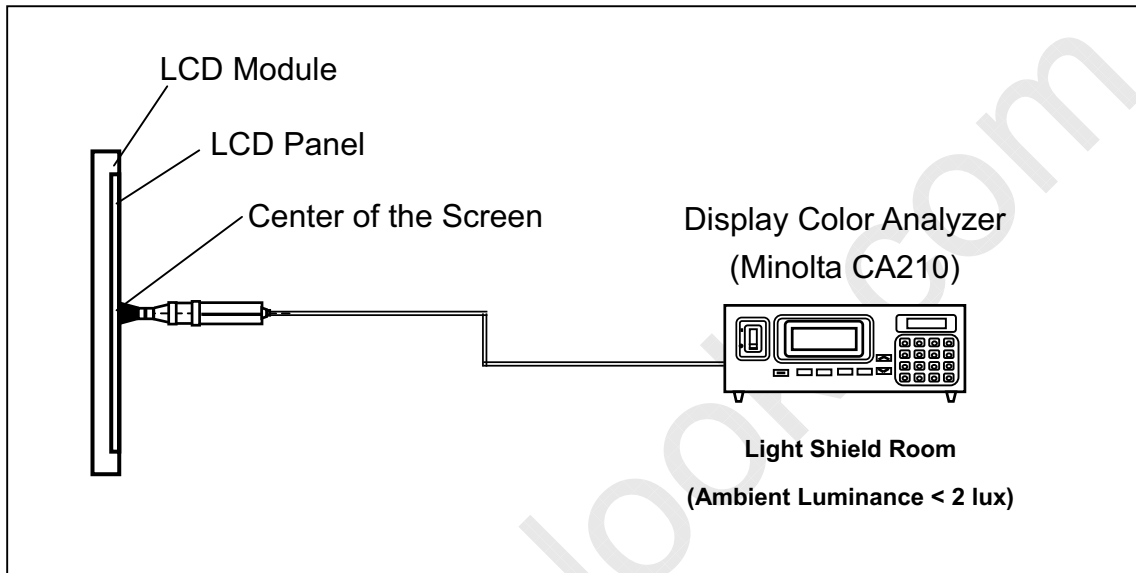
Note (8) Definition of White Variation (δW):

Measure the luminance of gray level 255 at 5 points

$$\delta W = \text{Maximum} [L(1), L(2), L(3), L(4), L(5)] / \text{Minimum} [L(1), L(2), L(3), L(4), L(5)]$$

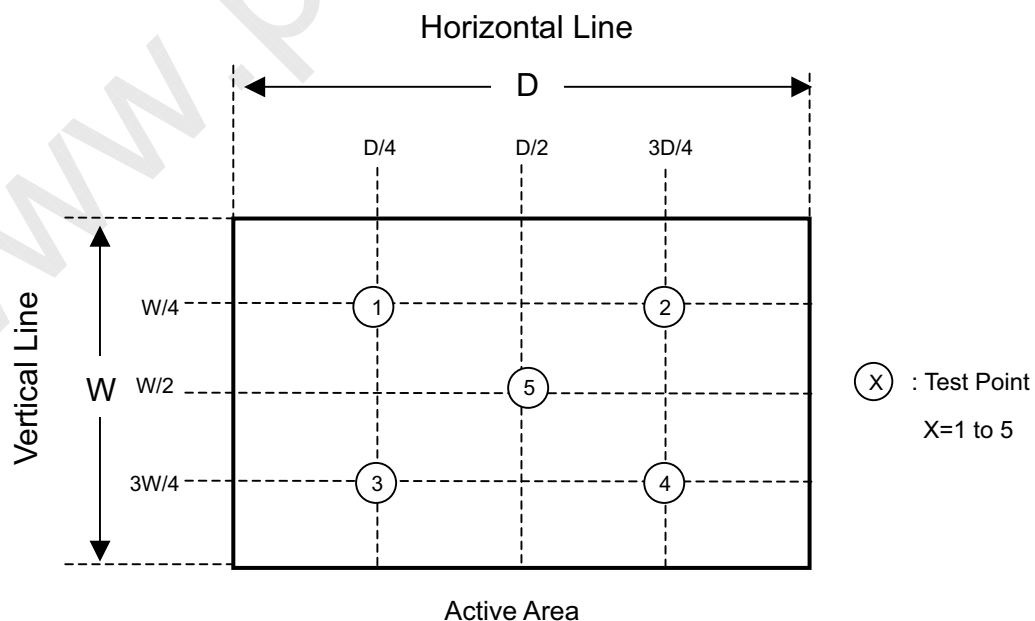

8. PACKAGING

8.1 PACKING SPECIFICATIONS

- (1) 3 LCD TV modules / 1 Box
- (2) Box dimensions : 790(L) X 280 (W) X 564 (H)
- (3) Weight : approximately 19Kg (3 modules per box)

8.2 PACKING Method

Figures 8-1 and 8-2 are the packing method

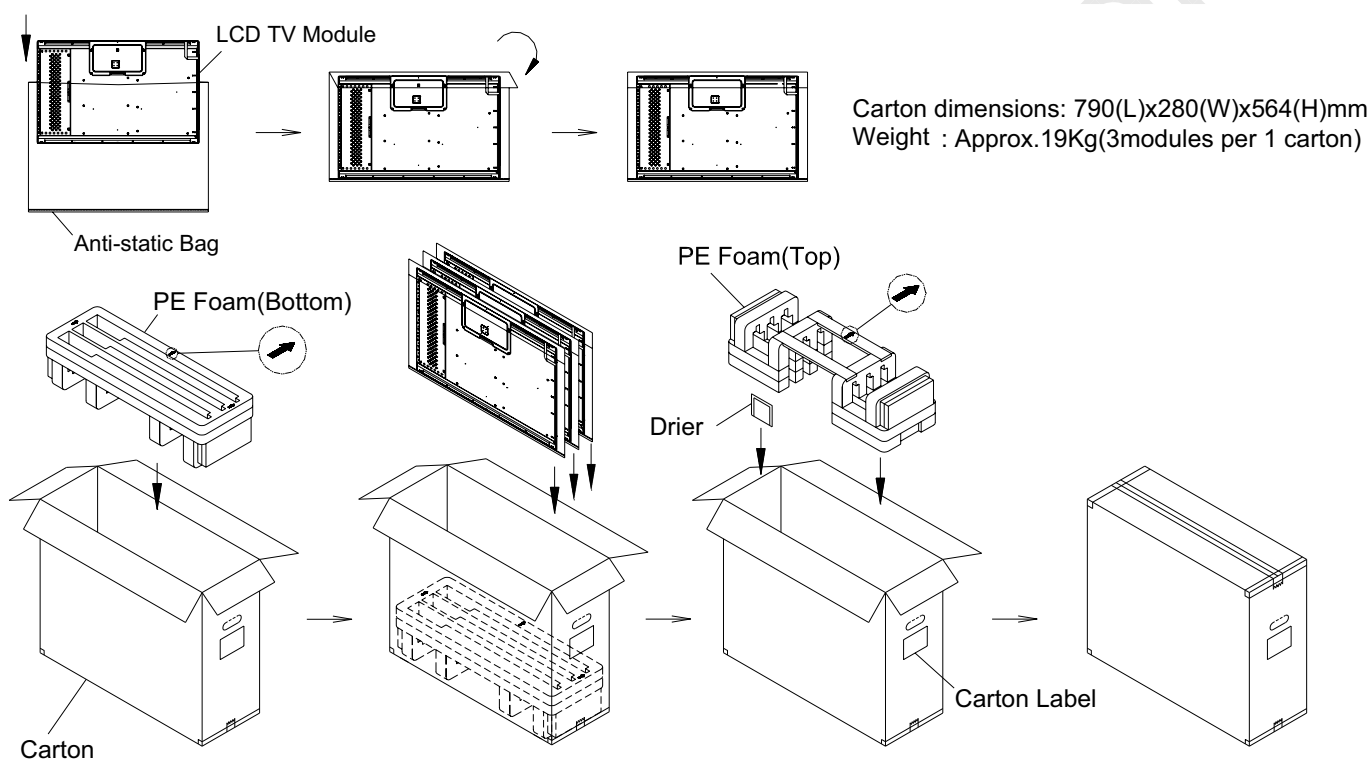
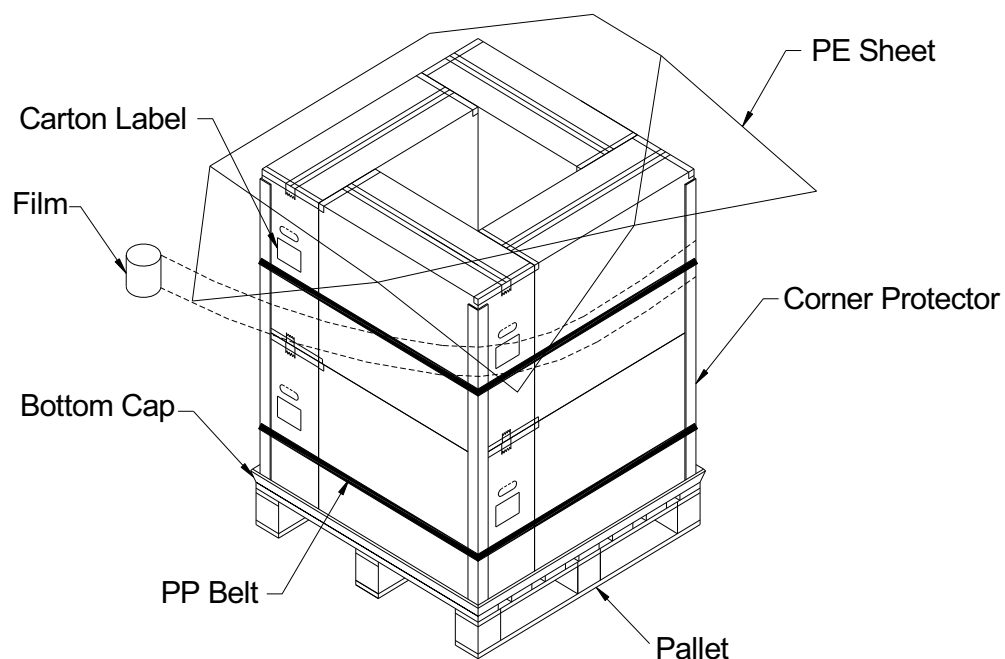

Figure.8-1 packing method

Corner Protector:L1130*50mm*50mm
Pallet:L1100*W1100*H135mm
Bottom Cap:L1100*W1100*H120mm
Pallet stack:L1100*W1100*H1273mm
Gross Weight:175kg



9. DEFINITION OF LABELS

9.1 CMO MODULE LABEL

The barcode nameplate is pasted on each module as illustration, and its definitions are as following explanation.

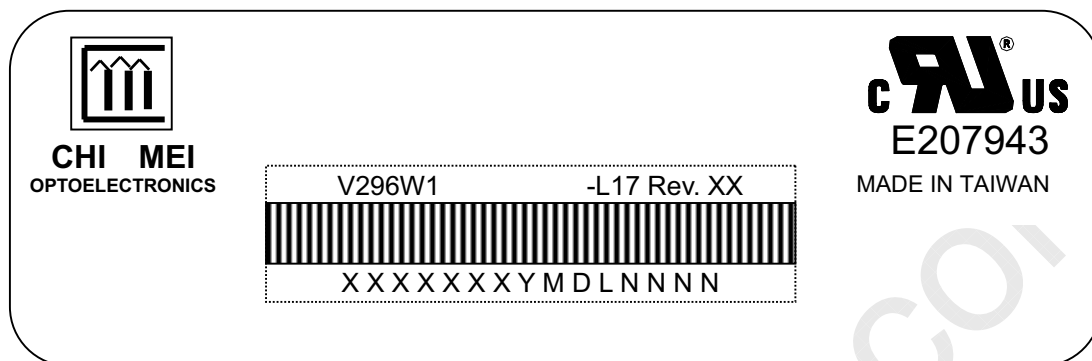

- (a) Model Name: V296W1-L17
 (b) Revision: Rev. XX, for example: A0, A1... B1, B2... or C1, C2...etc.
 (c) Serial ID: XXXXXXXXYMDLNNNN

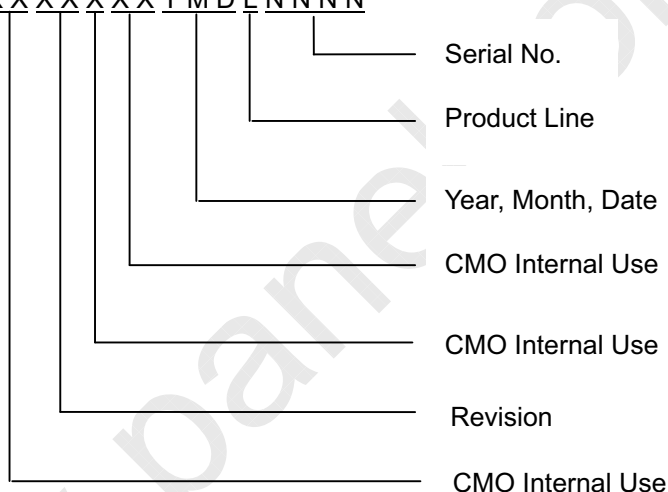

Serial ID includes the information as below:

- (a) Manufactured Date: Year: 1~9, for 2001~2009
 Month: 1~9, A~C, for Jan. ~ Dec.
 Day: 1~9, A~Y, for 1st to 31st, exclude I, O, and U.
- (b) Revision Code: Cover all the change
- (c) Serial No.: Manufacturing sequence of product
- (d) Product Line: 1 -> Line1, 2 -> Line 2, ...etc.

10. PRECAUTIONS

10.1 ASSEMBLY AND HANDLING PRECAUTIONS

- (1) Do not apply rough force such as bending or twisting to the module during assembly.
- (2) It is recommended to assemble or to install a module into the user's system in clean working areas. The dust and oil may cause electrical short or worsen the polarizer.
- (3) Do not apply pressure or impulse to the module to prevent the damage of LCD panel and Backlight.
- (4) Always follow the correct power-on sequence when the LCD module is turned on. This can prevent the damage and latch-up of the CMOS LSI chips.
- (5) Do not plug in or pull out the I/F connector while the module is in operation.
- (6) Do not disassemble the module.
- (7) Use a soft dry cloth without chemicals for cleaning, because the surface of polarizer is very soft and easily scratched.
- (8) Moisture can easily penetrate into LCD module and may cause the damage during operation.
- (9) High temperature or humidity may deteriorate the performance of LCD module. Please store LCD modules in the specified storage conditions.
- (10) When ambient temperature is lower than 10°C, the display quality might be reduced. For example, the response time will become slow, and the starting voltage of CCFL will be higher than that of room temperature.

10.2 SAFETY PRECAUTIONS

- (1) The startup voltage of a Backlight is approximately 1000 Volts. It may cause an electrical shock while assembling with the inverter. Do not disassemble the module or insert anything into the Backlight unit.
- (2) If the liquid crystal material leaks from the panel, it should be kept away from the eyes or mouth. In case of contact with hands, skin or clothes, it has to be washed away thoroughly with soap.
- (3) After the module's end of life, it is not harmful in case of normal operation and storage.

11. MECHANICAL CHARACTERISTICS

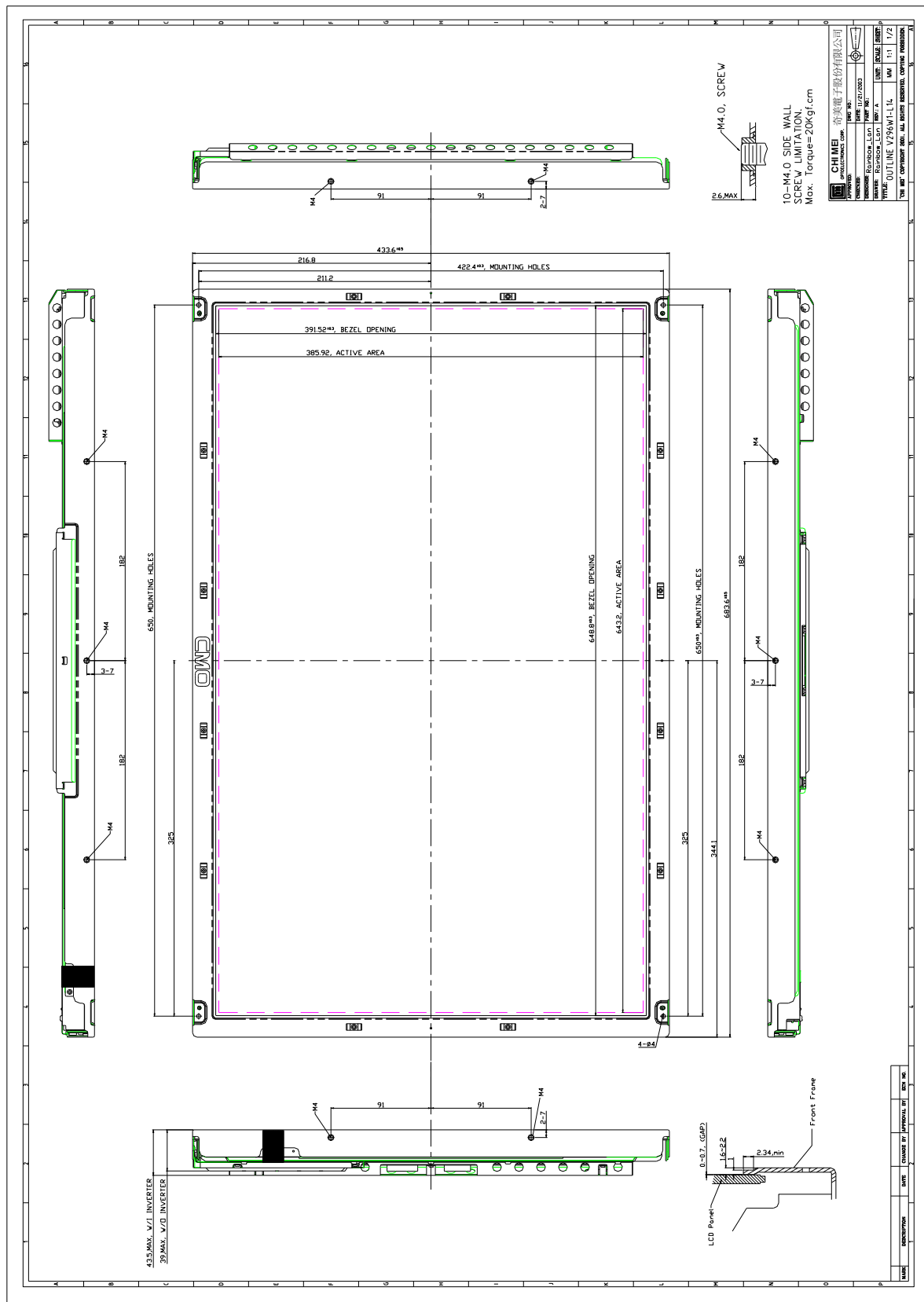

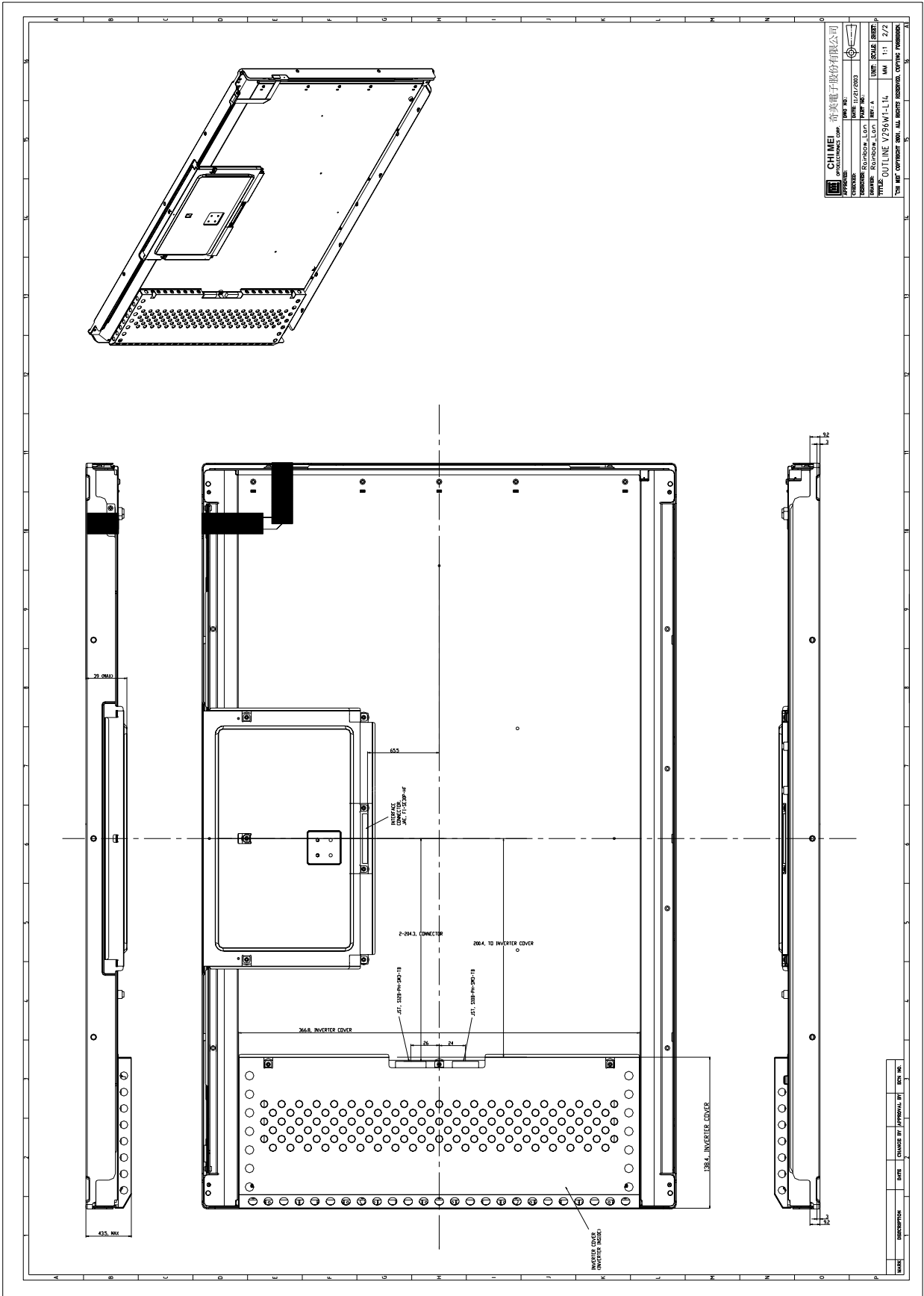



Issued Date: Feb. 20, 2004
Model No.: V296W1 - L17

Approval

