

- Tentative Specification
 Preliminary Specification
 Approval Specification

MODEL NO.: V29BJ1

SUFFIX: LE1

Customer:	
APPROVED BY	SIGNATURE
<u>Name / Title</u> _____	
Note	
_____ Please return 1 copy for your confirmation with your signature and comments.	

Approved By	Checked By	Prepared By
Chao-Chun Chung	Vincent Chou	Apple Wen

CONTENTS

REVISION HISTORY.....	4
1. GENERAL DESCRIPTION.....	5
1.1 OVERVIEW.....	5
1.2 FEATURES.....	5
1.3 APPLICATION.....	5
1.4 GENERAL SPECIFICATIONS.....	5
1.5 MECHANICAL SPECIFICATIONS.....	6
2. ABSOLUTE MAXIMUM RATINGS.....	7
2.1 ABSOLUTE RATINGS OF ENVIRONMENT.....	7
2.2 PACKAGE STORAGE.....	8
2.3 ELECTRICAL ABSOLUTE RATINGS.....	8
2.3.1 TFT LCD MODULE.....	8
2.3.2 BACKLIGHT UNIT.....	8
3. ELECTRICAL CHARACTERISTICS.....	9
3.1 TFT LCD MODULE.....	9
3.2 BACKLIGHT UNIT.....	12
3.2.1 LED LIGHT BAR CHARACTERISTICS.....	12
4. BLOCK DIAGRAM OF INTERFACE.....	13
4.1 TFT LCD MODULE.....	13
5. INPUT TERMINAL PIN ASSIGNMENT.....	14
5.1 TFT LCD Module Input.....	14
5.2 BLOCK DIAGRAM OF INTERFACE.....	16
5.3 LVDS INTERFACE.....	17
5.4 COLOR DATA INPUT ASSIGNMENT.....	18
6. INTERFACE TIMING.....	19
6.1.1 INPUT SIGNAL TIMING SPECIFICATIONS.....	19
6.2 POWER ON/OFF SEQUENCE.....	22
7. OPTICAL CHARACTERISTICS.....	23
7.1 TEST CONDITIONS.....	23



7.2 OPTICAL SPECIFICATIONS 24

8. PRECAUTIONS 28

 8.1 ASSEMBLY AND HANDLING PRECAUTIONS 28

 8.2 SAFETY PRECAUTIONS..... 28

9. DEFINITION OF LABELS..... 29

 9.1 MODULE LABEL 29

 9.2 CARTON LABEL..... 30

10. PACKAGING 31

 10.1 PACKAGING SPECIFICATIONS 31

 10.2 PACKAGING METHOD 31

11. MECHANICAL CHARACTERISTIC 32

REVISION HISTORY

Version	Date	Page(New)	Section	Description
Ver. 0.0	Jan.12, 2012	All	All	The tentative specification was first issued.

1. GENERAL DESCRIPTION

1.1 OVERVIEW

V290BJ1-LE1 is a 29" TFT Liquid Crystal Display module with 2U-CCFL Backlight unit and **1ch-LVDS** interface.

This module supports **1366 x 768 HDTV** format and can display 16.7M colors (8-bit). The inverter module for backlight is built-in.

1.2 FEATURES

- High brightness (250 nits)
- High contrast ratio (2500:1)
- Fast response time (Gray to gray average **(8.5) ms**)
- High color saturation (NTSC 68%)
- HDTV (1366 x 768 pixels) resolution
- DE (Data Enable) only mode
- LVDS (Low Voltage Differential Signaling) interface
- Optimized response time for 50/60 Hz frame rate
- Ultra wide viewing angle : Super MVA technology
- RoHS compliance

1.3 APPLICATION

- Standard Living Room TVs.
- Public Display Application.
- Home Theater Application.
- MFM Application.

1.4 GENERAL SPECIFICATIONS

Item	Specification	Unit	Note
Active Area	631.092 (H) x 354.816 (V) (29" diagonal)	mm	(1)
Bezel Opening Area	635 (H) x 358.8 (V)	mm	
Driver Element	a-si TFT active matrix	-	-
Pixel Number	1366 x R.G.B. x 768	pixel	-
Pixel Pitch(Sub Pixel)	0.154 (H) x 0.462 (V)	mm	-
Pixel Arrangement	RGB Vertical Stripe	-	-
Display Colors	16.7M	color	-
Display Operation Mode	Transmissive mode / Normally black	-	-
Surface Treatment	Anti-Glare coating (Haze 3.5%)	-	(2)

Note (1) Please refer to the attached drawings in chapter 9 for more information about the front and back outlines.

Note (2) The spec. of the surface treatment is temporarily for this phase. CMI reserves the rights to change this feature.

1.5 MECHANICAL SPECIFICATIONS

Item		Min.	Typ.	Max.	Unit	Note
Module Size	Horizontal (H)	653.8	654.8	545.8	mm	(1), (2)
	Vertical (V)	379.7	380.7	381.7	mm	
	Depth (D)	18.3	19.3	20.3	mm	
Weight		—	TBD	—	—	—

Note (1) Please refer to the attached drawings for more information of front and back outline dimensions.

Note (2) Module Depth is between bezel to T-CON cover.

2. ABSOLUTE MAXIMUM RATINGS
2.1 ABSOLUTE RATINGS OF ENVIRONMENT

Item	Symbol	Value		Unit	Note
		Min.	Max.		
Storage Temperature	TST	-20	+60	°C	(1)
Operating Ambient Temperature	TOP	0	50	°C	(1), (2)
Shock (Non-Operating)	SNOP	-	50	G	(3), (5)
Vibration (Non-Operating)	VNOP	-	1.0	G	(4), (5)

Note (1) Temperature and relative humidity range is shown in the figure below.

(a) 90 %RH Max. ($T_a \leq 40$ °C).

(b) Wet-bulb temperature should be 39 °C Max. ($T_a > 40$ °C).

(c) No condensation.

Note (2) The maximum operating temperature is based on the test condition that the surface temperature of display area is less than or equal to 65 °C with LCD module alone in a temperature controlled chamber. Thermal management should be considered in final product design to prevent the surface temperature of display area from being over 65 °C. The range of operating temperature may degrade in case of improper thermal management in final product design.

Note (3) 11 ms, half sine wave, 1 time for $\pm X$, $\pm Y$, $\pm Z$.

Note (4) 10 ~ 200 Hz, 10 min, 1 time each X, Y, Z.

Note (5) At testing Vibration and Shock, the fixture in holding the module has to be hard and rigid enough so that the module would not be twisted or bent by the fixture.

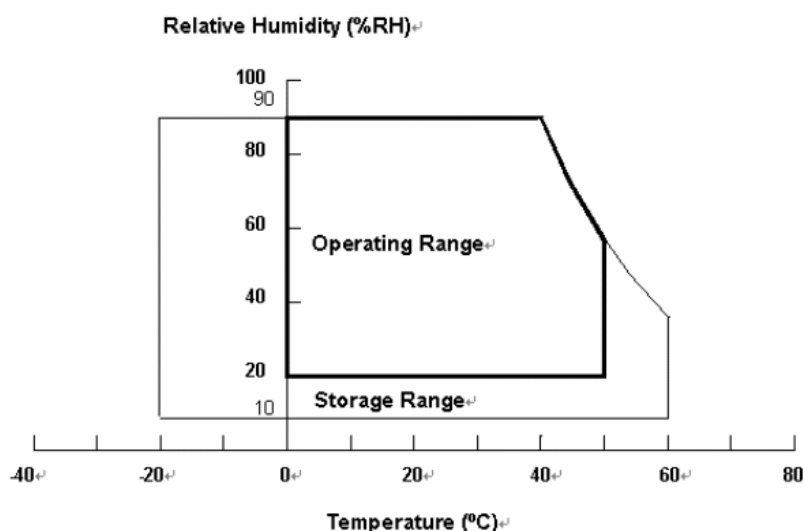

2.2 PACKAGE STORAGE

When storing modules as spares for a long time, the following precaution is necessary.

- (a) Do not leave the module in high temperature, and high humidity for a long time, It is highly recommended to store the module with temperature from 0 to 35 °C at normal humidity without condensation.
- (b) The module shall be stroed in dark place. Do not store the TFT-LCD module in direct sunlight or fluorescent light.

2.3 ELECTRICAL ABSOLUTE RATINGS

2.3.1 TFT LCD MODULE

Item	Symbol	Value		Unit	Note
		Min.	Max.		
Power Supply Voltage	VCC	-0.3	13.5	V	(1)
Logic Input Voltage	VIN	-0.3	3.6	V	

2.3.2 BACKLIGHT UNIT

Item	Symbol	Value		Unit	Note
		Min.	Max.		
Light Bar Voltage	VW	—	170	V _{DC}	(1)

Note (1) Permanent damage to the device may occur if maximum values are exceeded. Function operation should be restricted to the conditions described under Normal Operating Conditions

3. ELECTRICAL CHARACTERISTICS

3.1 TFT LCD MODULE

(Ta = 25 ± 2 °C)

Parameter		Symbol	Value			Unit	Note
			Min.	Typ.	Max.		
Power Supply Voltage		V _{CC}	10.8	12	13.2	V	(1)
Rush Current		I _{RUSH}	—	—	(3.9)	A	(2)
Power consumption	White Pattern	P _T	—	(4.92)	(6.00)	W	(3)
	Black Pattern	P _T	—	(3.60)	(4.44)		
	Horizontal Stripe	P _T	—	(5.76)	(7.08)		
Power Supply Current	White Pattern	—	—	(0.41)	(0.50)	A	
	Black Pattern	—	—	(0.30)	(0.37)		
	Horizontal Stripe	—	—	(0.48)	(0.59)		
LVDS interface	Differential Input High Threshold Voltage	V _{LVTH}	+100	—	—	mV	(4)
	Differential Input Low Threshold Voltage	V _{LVTL}	—	—	-100	mV	
	Common Input Voltage	V _{CM}	1.0	1.2	1.4	V	
	Differential input voltage (single-end)	V _{ID}	200	—	600	mV	
	Terminating Resistor	R _T	—	100	—	ohm	
CMOS interface	Input High Threshold Voltage	V _{IH}	2.7	—	3.3	V	
	Input Low Threshold Voltage	V _{IL}	0	—	0.7	V	

Note (1) The module should be always operated within the above ranges.

Note (2) Measurement condition :

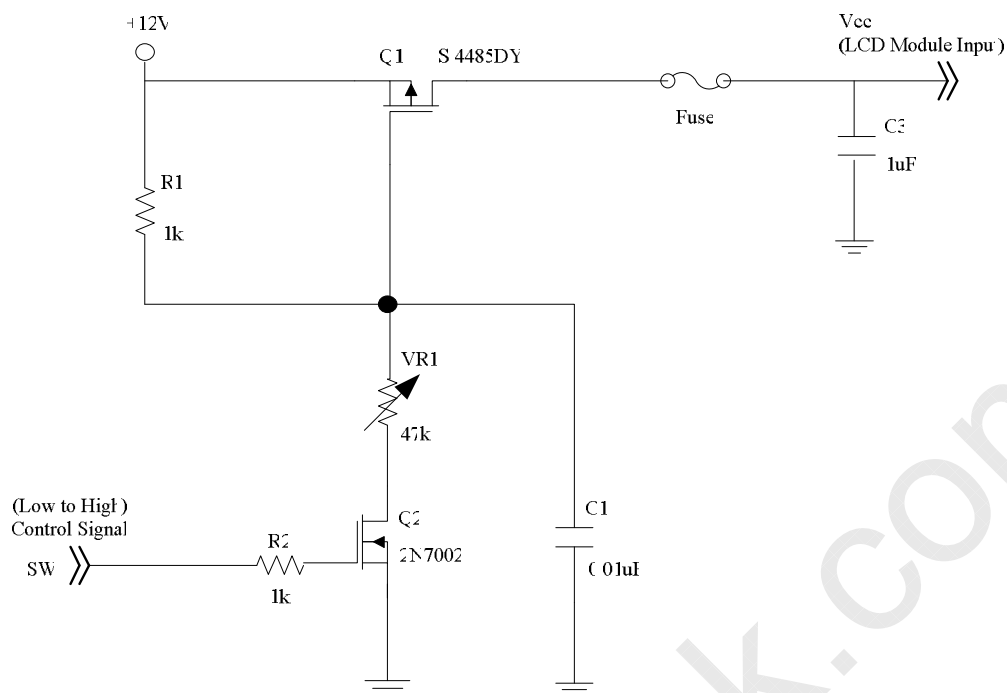

Vcc rising time is 470us

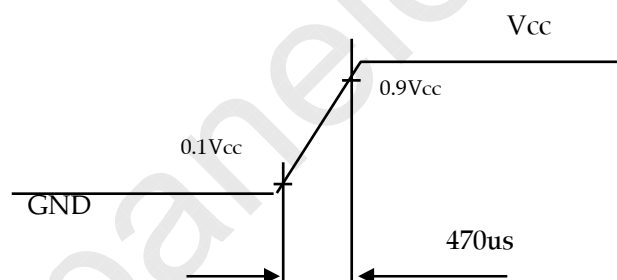

Note (3) The specified power supply current is under the conditions at $V_{cc} = 12\text{ V}$, $T_a = 25 \pm 2\text{ }^\circ\text{C}$, $f_v = 60\text{ Hz}$, whereas a power dissipation check pattern below is displayed.

a. White Pattern

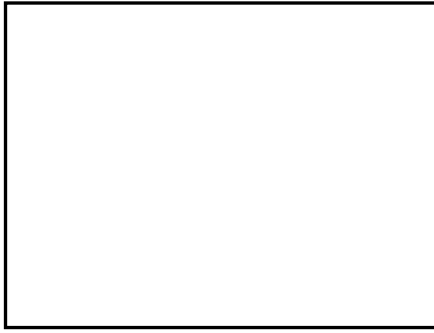

Active Area

b. Black Pattern



Active Area

c. Horizontal Pattern

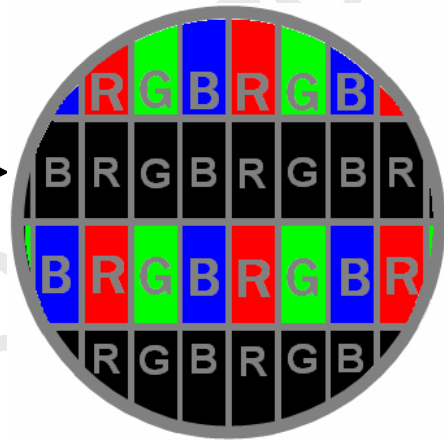
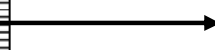
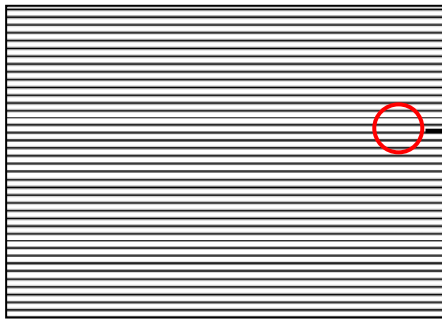

Note (4) The LVDS input characteristics are as follows:

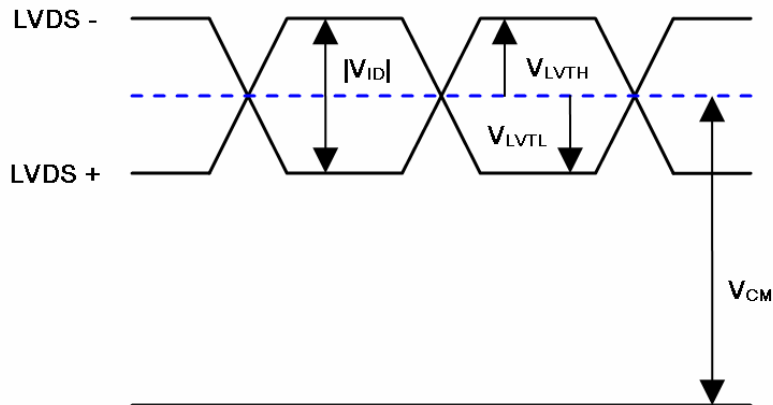

3.2 BACKLIGHT UNIT

3.2.1 LED LIGHT BAR CHARACTERISTICS

(Ta = 25 ± 2 °C)

Parameter	Symbol	Value			Unit	Note
		Min.	Typ.	Max.		
Light Bar Current	I _L	131.6	140	148.4	mA	(1) Duty=100% I _L =140mA
Light Bar Voltage	V _W	136.8	152.2	167.5	V _{DC}	I _L =140mA
Power Consumption	P _{BL}	20.1	21.3	22.6	W	Only LEDs Duty=100% I _{PIN} =140mA
Life time	—	30,000	—	—	Hrs	(1)

Note (1) The lifetime is defined as the time which luminance of the LED decays to 50% compared to the initial value, Operating condition: Continuous operating at Ta = 25±2°C, I_L=140 mA

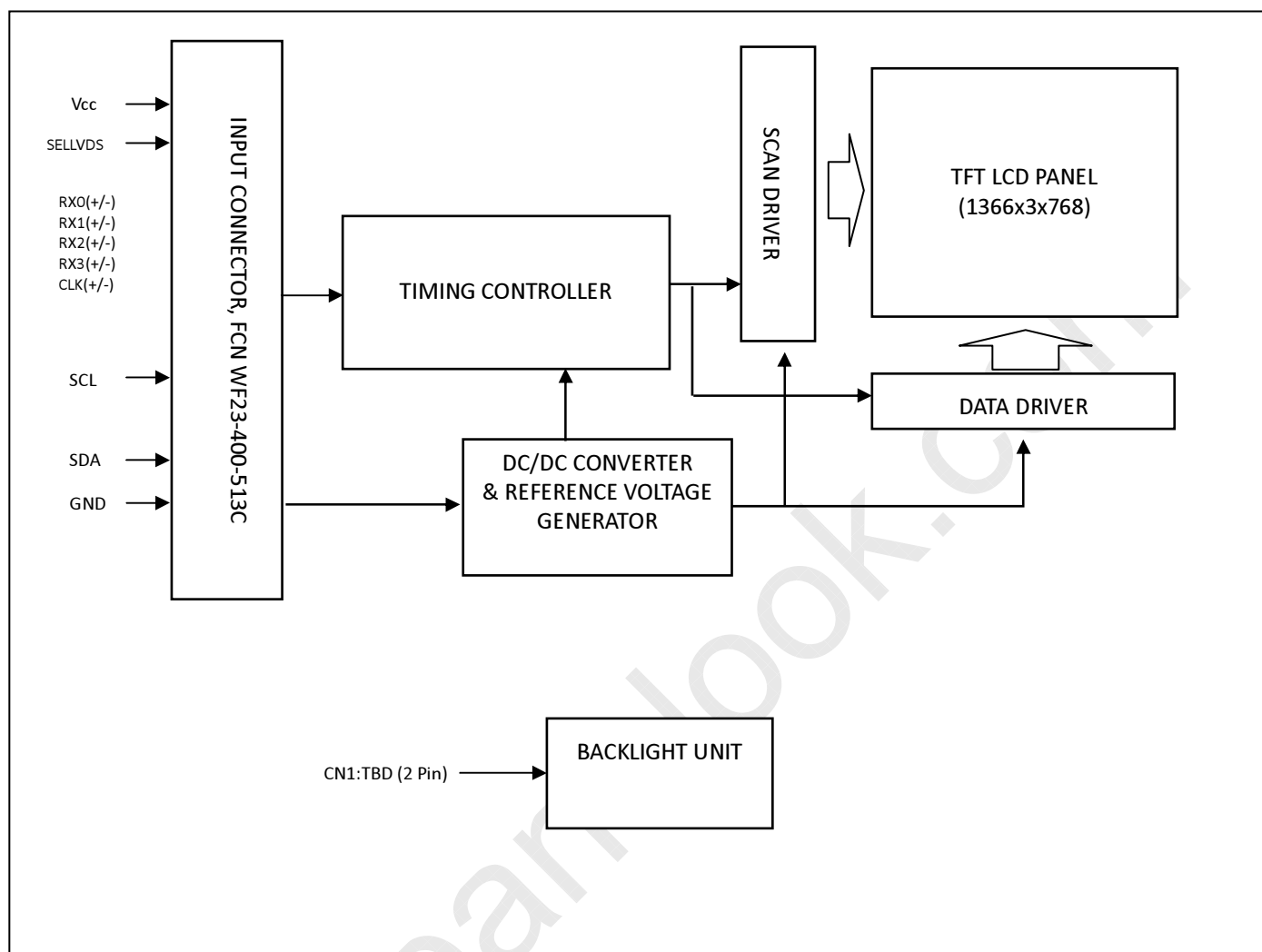
4. BLOCK DIAGRAM OF INTERFACE
4.1 TFT LCD MODULE

5. INPUT TERMINAL PIN ASSIGNMENT

5.1 TFT LCD Module Input

CNF1 Connector Pin Assignment (Foxconn GS23301-1321S-7H)

Pin	Name	Description	Note
1	VCC	Power supply: +12V	
2	VCC	Power supply: +12V	
3	VCC	Power supply: +12V	
4	VCC	Power supply: +12V	
5	GND	Ground	
6	GND	Ground	
7	GND	Ground	
8	NC	No connection	(2)
9	SELLVDS	LVDS data format Selection	(3)(4)
10	NC	No connection	(2)
11	GND	Ground	
12	RX0-	Negative transmission data of pixel 0	
13	RX0+	Positive transmission data of pixel 0	
14	GND	Ground	
15	RX1-	Negative transmission data of pixel 1	
16	RX1+	Positive transmission data of pixel 1	
17	GND	Ground	
18	RX2-	Negative transmission data of pixel 2	
19	RX2+	Positive transmission data of pixel 2	
20	GND	Ground	
21	RXCLK-	Negative of clock	
22	RXCLK+	Positive of clock	
23	GND	Ground	
24	RX3-	Negative transmission data of pixel 3	
25	RX3+	Positive transmission data of pixel 3	
26	GND	Ground	
27	NC	No connection	(2)
28	NC	No connection	
29	NC	No connection	
30	GND	Ground	

Note (1) Connector type: Foxconn GS23301-1321S-7H

LVDS connector pin order defined as follows

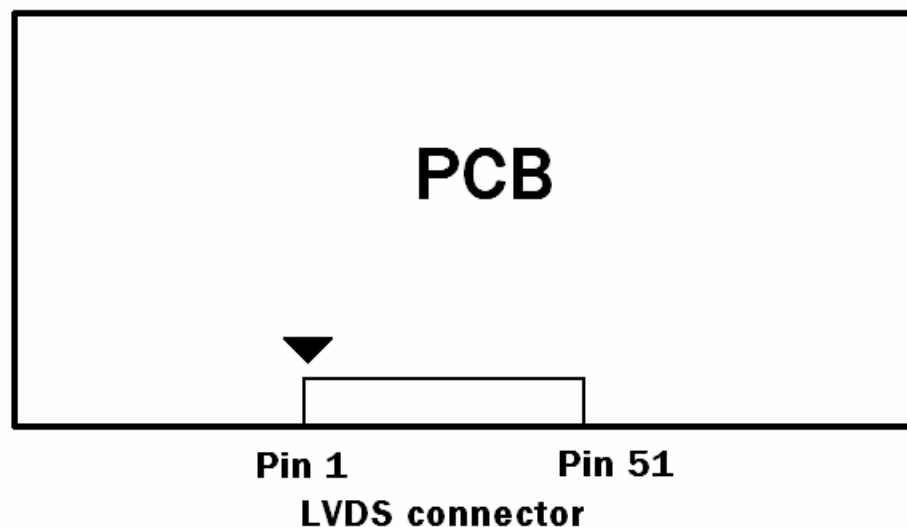

Note (2) Reserved for internal use. Please leave it open.

Note (3) Connect to Open or +3.3V: VESA Format, connect to GND: JEIDA Format.

SELLVDS	Mode
H(default)	VESA
L	JEIDA

L: Connect to GND, H: Connect to +3.3V

Note (4) LVDS signal pin connected to the LCM side has the following diagram. R1 in the system side should be less than 1K Ohm. ($R1 < 1K \text{ Ohm}$)

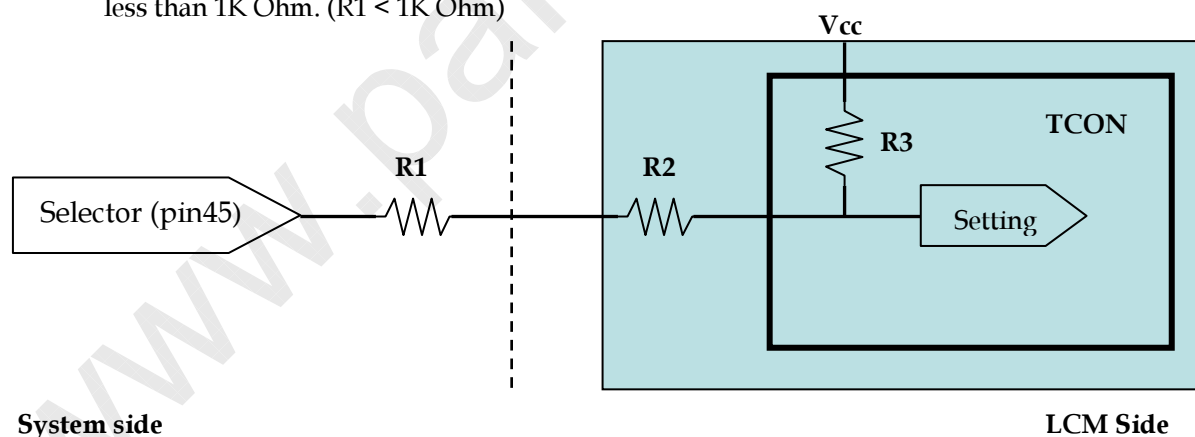

Note (5) Two pixel data send into the module for every clock cycle. The first pixel of the frame is odd pixel and the second pixel is even pixel.

5.2 BLOCK DIAGRAM OF INTERFACE

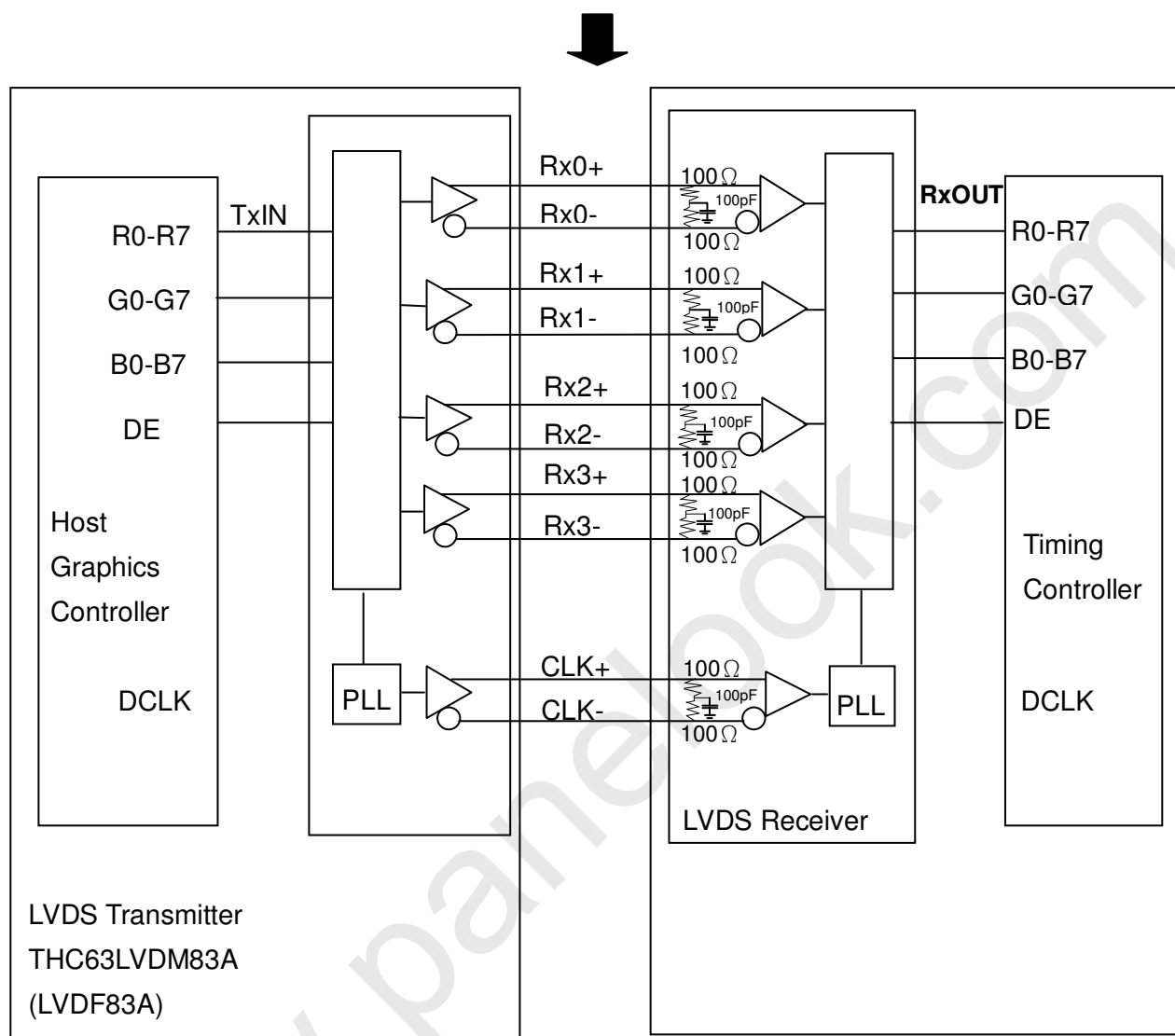

R0~R7	Pixel R data	DE	Data enable signal
G0~G7	Pixel G data	DCLK	Data clock signal
B0~B7	Pixel B data		

Notes (1) The system must have the transmitter to drive the module.

Notes (2) LVDS cable impedance shall be 50 ohms per signal line or about 100 ohms per twist-pair line when it is used differentially.

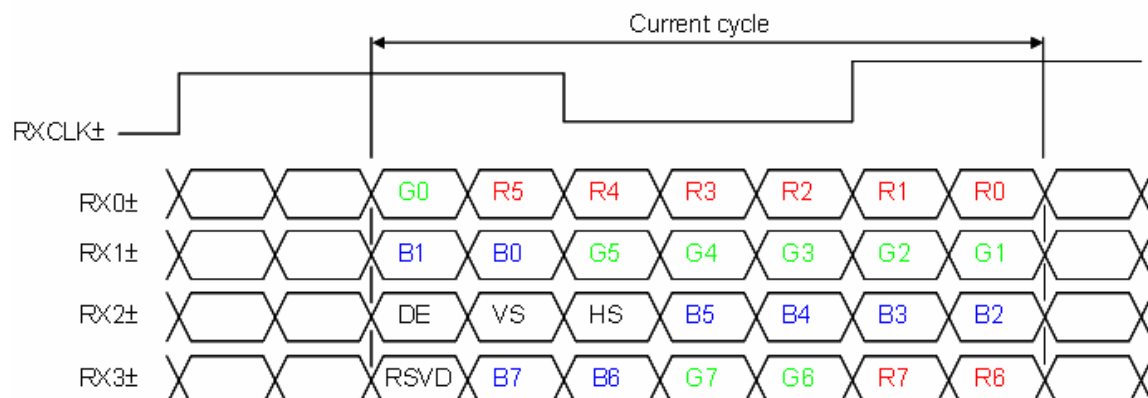
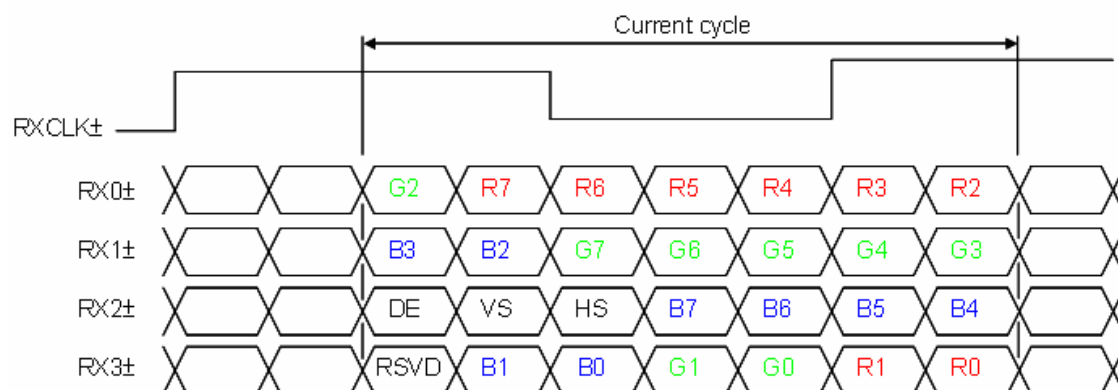
5.3 LVDS INTERFACE
VESA LVDS format : (SELLVDS pin=H/Open)

JEDIA LVDS format : (SELLVDS pin=L)

R0~R7	Pixel R Data (7; MSB, 0; LSB)	DE	Data enable signal
G0~G7	Pixel G Data (7; MSB, 0; LSB)	DCLK	Data clock signal
B0~B7	Pixel B Data (7; MSB, 0; LSB)		

Note (1) RSVD (reserved) pins on the transmitter shall be "H" or "L".

5.4 COLOR DATA INPUT ASSIGNMENT

The brightness of each primary color (red, green and blue) is based on the 8-bit gray scale data input for the color. The higher the binary input, the brighter the color. The table below provides the assignment of the color versus data input.

Color		Data Signal																						
		Red								Green								Blue						
		R7	R6	R5	R4	R3	R2	R1	R0	G7	G6	G5	G4	G3	G2	G1	G0	B7	B6	B5	B4	B3	B2	B1
Basic Colors	Black	0	0	0	0	0	0	0	0	0	0	0	0	0	0	0	0	0	0	0	0	0	0	0
	Red	1	1	1	1	1	1	1	1	0	0	0	0	0	0	0	0	0	0	0	0	0	0	0
	Green	0	0	0	0	0	0	0	0	1	1	1	1	1	1	1	1	0	0	0	0	0	0	0
	Blue	0	0	0	0	0	0	0	0	0	0	0	0	0	0	0	0	1	1	1	1	1	1	1
	Cyan	0	0	0	0	0	0	0	0	1	1	1	1	1	1	1	1	1	1	1	1	1	1	1
	Magenta	1	1	1	1	1	1	1	1	0	0	0	0	0	0	0	0	1	1	1	1	1	1	1
	Yellow	1	1	1	1	1	1	1	1	1	1	1	1	1	1	1	1	0	0	0	0	0	0	0
	White	1	1	1	1	1	1	1	1	1	1	1	1	1	1	1	1	1	1	1	1	1	1	1
Gray Scale Of Red	Red (0) / Dark	0	0	0	0	0	0	0	0	0	0	0	0	0	0	0	0	0	0	0	0	0	0	
	Red (1)	0	0	0	0	0	0	0	1	0	0	0	0	0	0	0	0	0	0	0	0	0	0	
	Red (2)	0	0	0	0	0	0	1	0	0	0	0	0	0	0	0	0	0	0	0	0	0	0	
	⋮	⋮	⋮	⋮	⋮	⋮	⋮	⋮	⋮	⋮	⋮	⋮	⋮	⋮	⋮	⋮	⋮	⋮	⋮	⋮	⋮	⋮		
	⋮	⋮	⋮	⋮	⋮	⋮	⋮	⋮	⋮	⋮	⋮	⋮	⋮	⋮	⋮	⋮	⋮	⋮	⋮	⋮	⋮	⋮		
	Red (253)	1	1	1	1	1	1	0	1	0	0	0	0	0	0	0	0	0	0	0	0	0	0	
	Red (254)	1	1	1	1	1	1	1	0	0	0	0	0	0	0	0	0	0	0	0	0	0	0	
	Red (255)	1	1	1	1	1	1	1	1	0	0	0	0	0	0	0	0	0	0	0	0	0	0	
Gray Scale Of Green	Green (0) / Dark	0	0	0	0	0	0	0	0	0	0	0	0	0	0	0	0	0	0	0	0	0	0	
	Green (1)	0	0	0	0	0	0	0	0	0	0	0	0	0	0	0	1	0	0	0	0	0	0	
	Green (2)	0	0	0	0	0	0	0	0	0	0	0	0	0	0	1	0	0	0	0	0	0	0	
	⋮	⋮	⋮	⋮	⋮	⋮	⋮	⋮	⋮	⋮	⋮	⋮	⋮	⋮	⋮	⋮	⋮	⋮	⋮	⋮	⋮	⋮		
	⋮	⋮	⋮	⋮	⋮	⋮	⋮	⋮	⋮	⋮	⋮	⋮	⋮	⋮	⋮	⋮	⋮	⋮	⋮	⋮	⋮	⋮		
	Green (253)	0	0	0	0	0	0	0	0	1	1	1	1	1	1	0	1	0	0	0	0	0	0	
	Green (254)	0	0	0	0	0	0	0	0	1	1	1	1	1	1	1	0	0	0	0	0	0	0	
	Green (255)	0	0	0	0	0	0	0	0	1	1	1	1	1	1	1	1	0	0	0	0	0	0	
Gray Scale Of Blue	Blue (0) / Dark	0	0	0	0	0	0	0	0	0	0	0	0	0	0	0	0	0	0	0	0	0	0	
	Blue (1)	0	0	0	0	0	0	0	0	0	0	0	0	0	0	0	0	0	0	0	0	0	1	
	Blue (2)	0	0	0	0	0	0	0	0	0	0	0	0	0	0	0	0	0	0	0	0	0	1	
	⋮	⋮	⋮	⋮	⋮	⋮	⋮	⋮	⋮	⋮	⋮	⋮	⋮	⋮	⋮	⋮	⋮	⋮	⋮	⋮	⋮	⋮		
	⋮	⋮	⋮	⋮	⋮	⋮	⋮	⋮	⋮	⋮	⋮	⋮	⋮	⋮	⋮	⋮	⋮	⋮	⋮	⋮	⋮	⋮		
	Blue (253)	0	0	0	0	0	0	0	0	0	0	0	0	0	0	0	1	1	1	1	1	1	0	
	Blue (254)	0	0	0	0	0	0	0	0	0	0	0	0	0	0	0	1	1	1	1	1	1	0	
	Blue (255)	0	0	0	0	0	0	0	0	0	0	0	0	0	0	0	1	1	1	1	1	1	1	

Note (1) 0: Low Level Voltage, 1: High Level Voltage

6. INTERFACE TIMING

6.1.1 INPUT SIGNAL TIMING SPECIFICATIONS

(Ta = 25 ± 2 °C)

The input signal timing specifications are shown as the following table and timing diagram.

Signal	Item	Symbol	Min.	Typ.	Max.	Unit	Note
LVDS Receiver Clock	Frequency	$F_{clk_{in}}$ (=1/TC)	60	76	82	MHz	
	Input cycle to cycle jitter	T_{rcl}	—	—	200	ps	(3)
	Spread spectrum modulation range	$F_{clk_{in_mod}}$	$F_{clk_{in}}-3\%$	—	$F_{clk_{in}}+3\%$	MHz	(4)
	Spread spectrum modulation frequency	F_{SSM}	—	—	300	KHz	
LVDS Receiver Data	Receiver Skew Margin	T_{RSKM}	-600	—	600	ps	(5)
Vertical Active Display Term	Frame Rate	F_{r5}	47	50	53	Hz	(6)
		F_{r6}	57	60	63	Hz	
	Total	T_v	(778)	806	(986)	Th	$T_v=T_{vd}+T_{vb}$
	Display	T_{vd}	768	768	768	Th	—
	Blank	T_{vb}	(10)	38	(218)	Th	—
Horizontal Active Display Term	Total	T_h	(1446)	1560	(1936)	Tc	$T_h=T_{hd}+T_{hb}$
	Display	T_{hd}	1366	1366	1366	Tc	—
	Blank	T_{hb}	(80)	194	(570)	Tc	—

Note (1) Please make sure the range of pixel clock has follow the below equation :

$$F_{clk_{in(max)}} \geq F_{r6} \times T_v \times T_h$$

$$F_{r5} \times T_v \times T_h \geq F_{clk_{in(min)}}$$

Note (2) This module is operated in DE only mode and please follow the input signal timing diagram below :

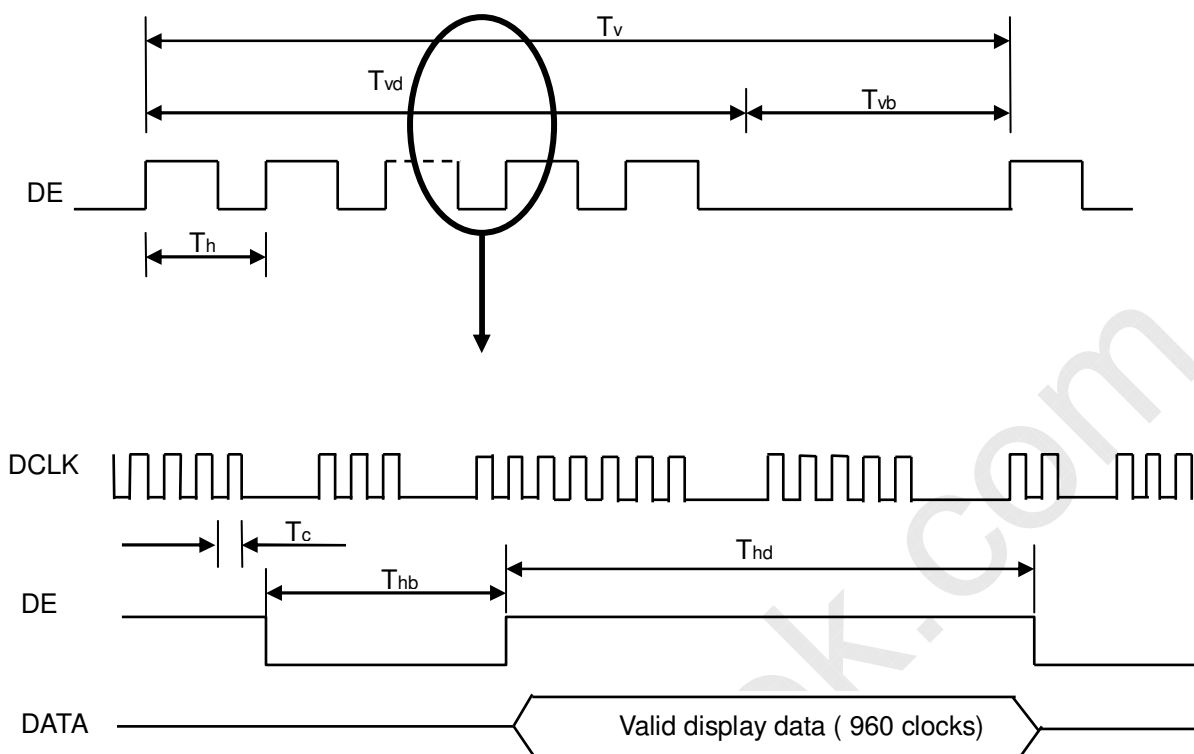

Note (3) The input clock cycle-to-cycle jitter is defined as below figures. $Trcl = |T_1 - T_2|$

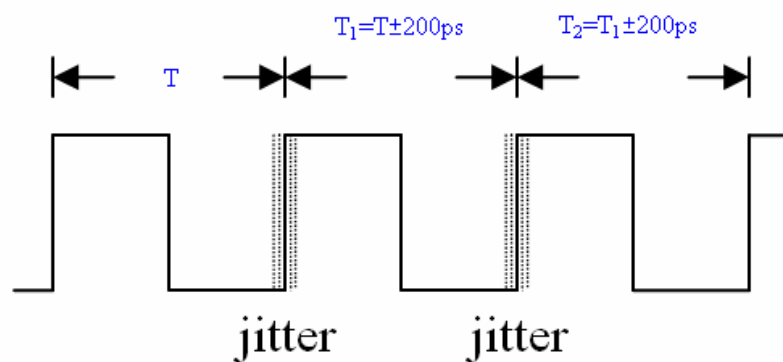

Note (4) The SSCG (Spread spectrum clock generator) is defined as below figures.

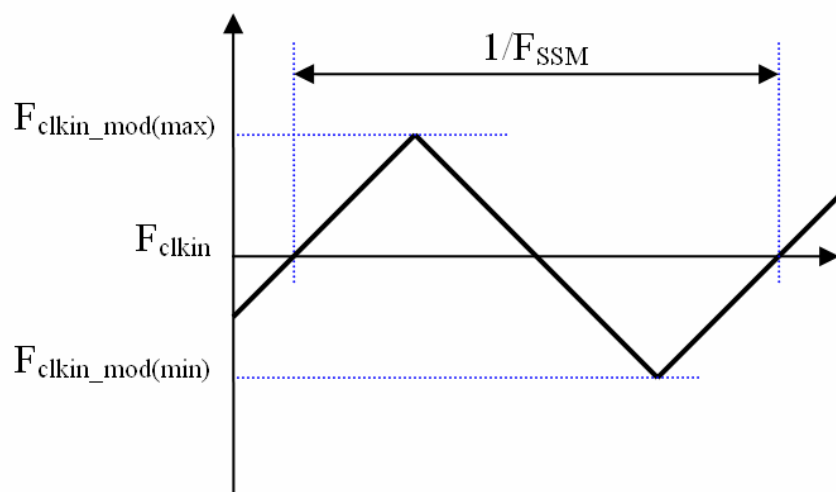

Note (5) The LVDS timing diagram and the time of receiver skew margin is defined and showing as the following figures.

LVDS RECEIVER INTERFACE TIMING DIAGRAM

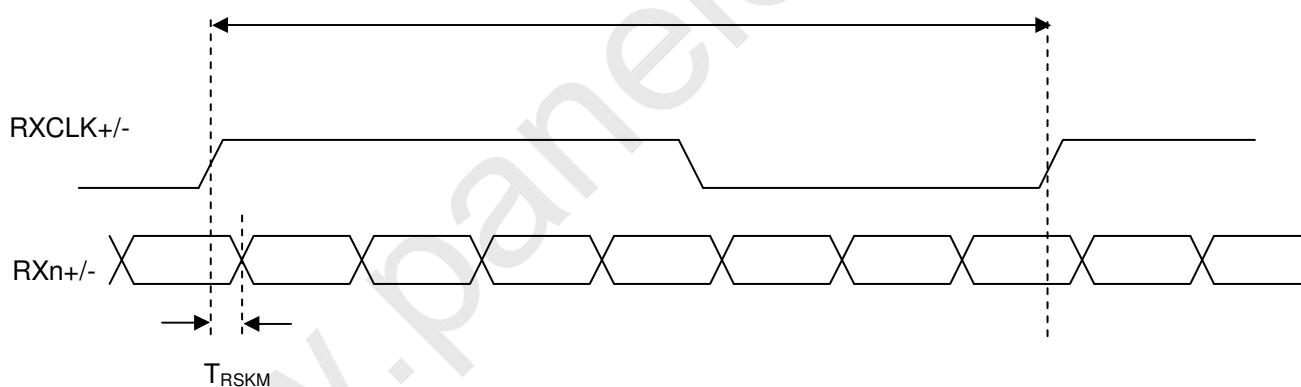

6.2 POWER ON/OFF SEQUENCE

($T_a = 25 \pm 2^\circ\text{C}$)

To prevent a latch-up or DC operation of LCD module, the power on/off sequence should be as the diagram below.

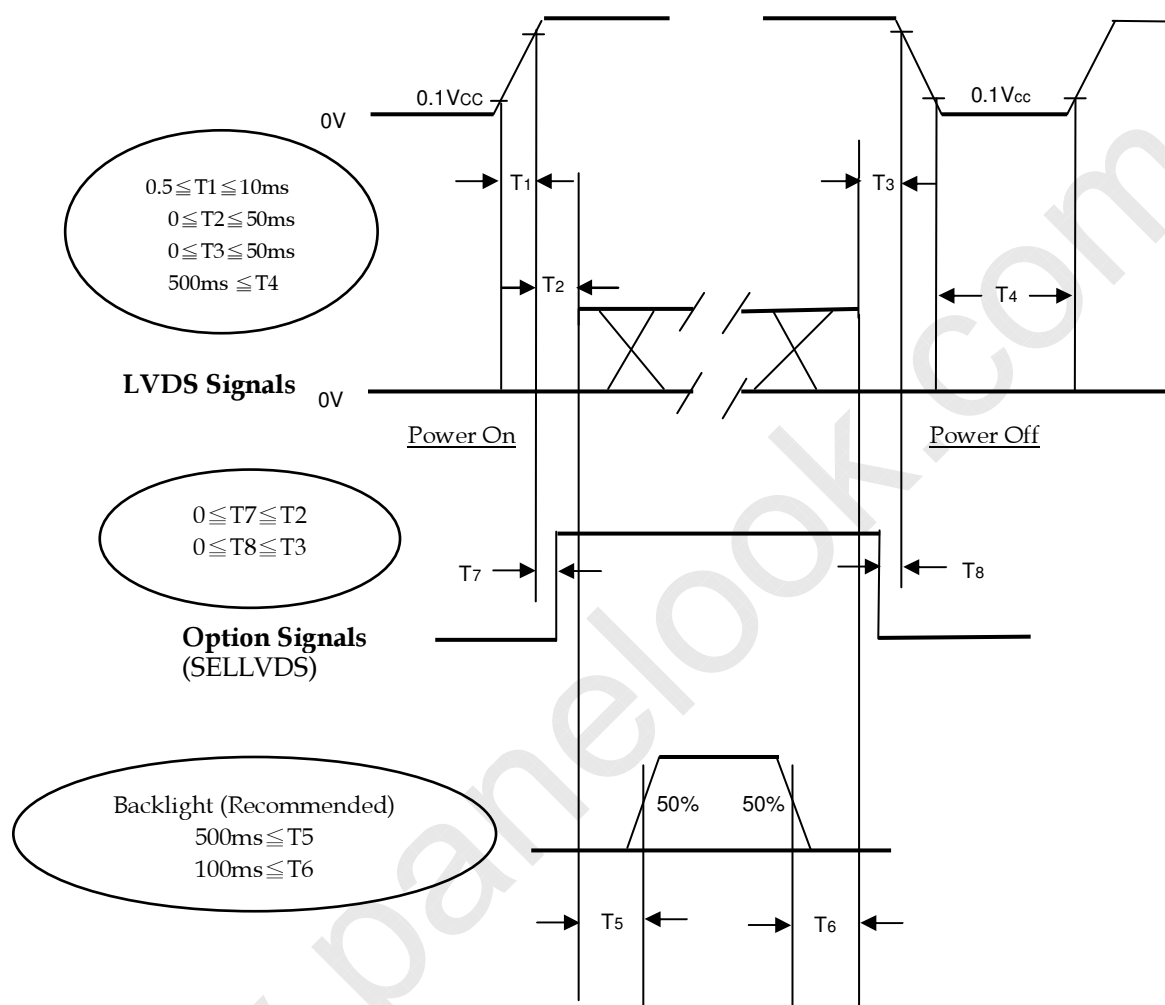

Power ON/OFF Sequence

Note (1) The supply voltage of the external system for the module input should follow the definition of Vcc.

Note (2) Apply the lamp voltage within the LCD operation range. When the backlight turns on before the LCD operation or the LCD turns off before the backlight turns off, the display may momentarily become abnormal screen.

Note (3) In case of Vcc is in off level, please keep the level of input signals on the low or high impedance. If $T2 < 0$, that maybe cause electrical overstress failure.

Note (4) T4 should be measured after the module has been fully discharged between power off and on period.

Note (5) Interface signal shall not be kept at high impedance when the power is on.

7. OPTICAL CHARACTERISTICS
7.1 TEST CONDITIONS

Item	Symbol	Value	Unit
Ambient Temperature	Ta	25±2	oC
Ambient Humidity	Ha	50±10	%RH
Supply Voltage	VCC	12	V
Input Signal	According to typical value in "3. ELECTRICAL CHARACTERISTICS"		
LED Current	IL	140	mA
Oscillating Frequency (Inverter)	FW		KHz
Vertical Frame Rate	Fr	60	Hz

Note : No guarantee level of water flow

The LCD module should be stabilized at given temperature for 1 hour to avoid abrupt temperature change during measuring. In order to stabilize the luminance, the measurement should be executed after lighting backlight for 1 hour in a windless room.

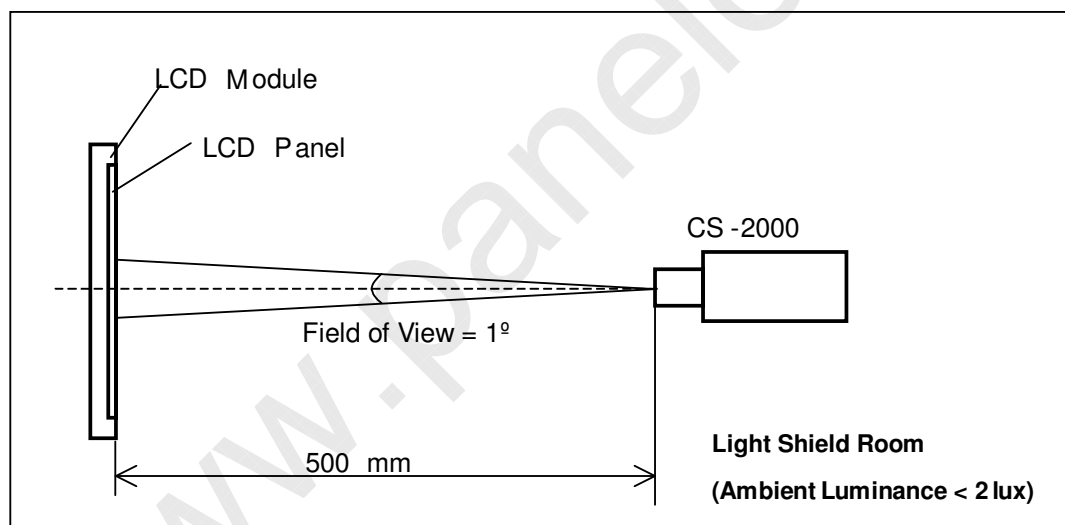

7.2 OPTICAL SPECIFICATIONS

The relative measurement methods of optical characteristics are shown in 7.2. The following items should be measured under the test conditions described in 7.1 and stable environment shown in 7.1.

Item		Symbol	Condition	Min.	Typ.	Max.	Unit	Note	
Contrast Ratio		CR	$\theta_x=0^\circ, \theta_y=0^\circ$ Viewing angle at normal direction	2100	3000		-	Note (2)	
Response Time		Gray to gray			8.5	16	ms	Note (3)	
Center Luminance of White		LC		200	250		cd/m ₂	Note (4)	
White Variation		δW				1.4	-	Note (6)	
Cross Talk		CT				4	%	Note (5)	
Color Chromaticity	Red	Rx		Typ. -0.03		Typ. +0.03		-	
		Ry						-	
	Green	Gx						-	
		Gy						-	
	Blue	Bx						-	
		By	-						
	White	Wx	0.280						
		Wy	0.290						
Color Gamut		C.G		68	-	%	NTSC		
Viewing Angle	Horizontal	θ_{x+}	80	88	-	Deg.	Note (1)		
		θ_{x-}	80	88	-				
	Vertical	θ_{Y+}	80	88	-				
		θ_{Y-}	80	88	-				

Note (1) Definition of Viewing Angle (θ_x, θ_y):

Viewing angles are measured by Conoscope Cono-80

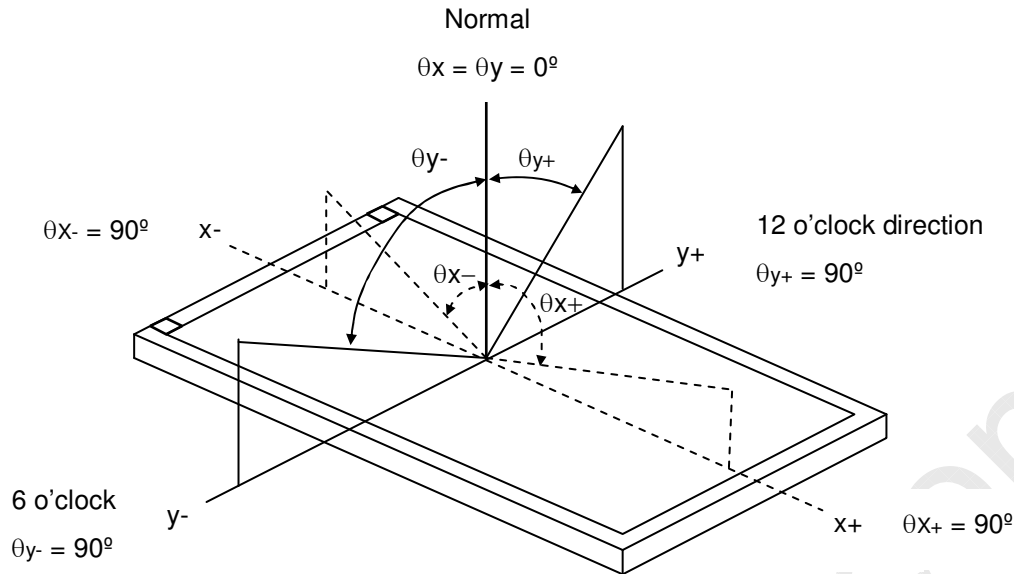

Note (2) Definition of Contrast Ratio (CR) :

The contrast ratio can be calculated by the following expression.

$$\text{Contrast Ratio (CR)} = \frac{\text{Surface Luminance with all white pixels}}{\text{Surface Luminance with all black pixels}}$$

CR = CR (X), where CR (X) is corresponding to the Contrast Ratio of the point X at the figure in Note (6).

Note (3) Definition of Gray-to-Gray Switching Time:

Optical Response

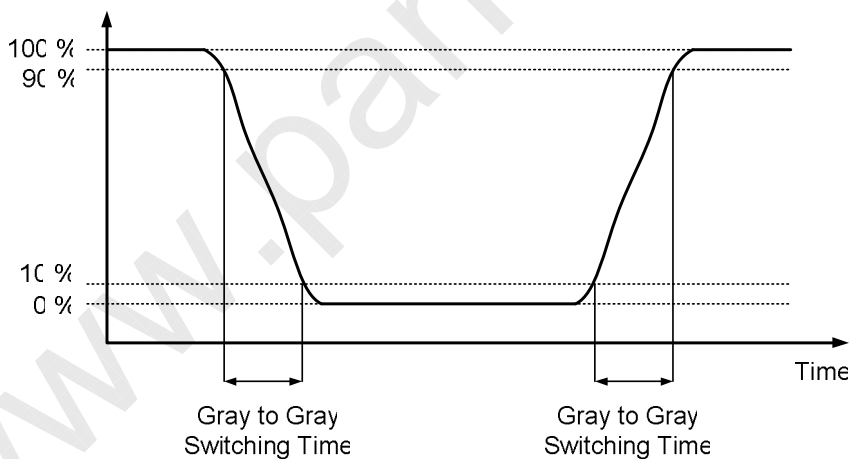

The driving signal means the signal of gray level 0, 31, 63, 95, 127, 159, 191, 223, 255.

Gray to gray average time means the average switching time of gray level 0, 31, 63, 95, 127, 159, 191, 223, 255. to each other.

Note (4) Definition of Luminance of White (L_C , L_{AVE}):

Measure the luminance of gray level 255 at center point and 5 points

$L_C = L(5)$, where $L(X)$ is corresponding to the luminance of the point X at the figure in Note (6).

Note (5) Definition of Cross Talk (CT):

$$CT = | Y_B - Y_A | / Y_A \times 100 (\%)$$

Where:

Y_A = Luminance of measured location without gray level 0 pattern (cd/m²)

Y_B = Luminance of measured location with gray level 0 pattern (cd/m²)

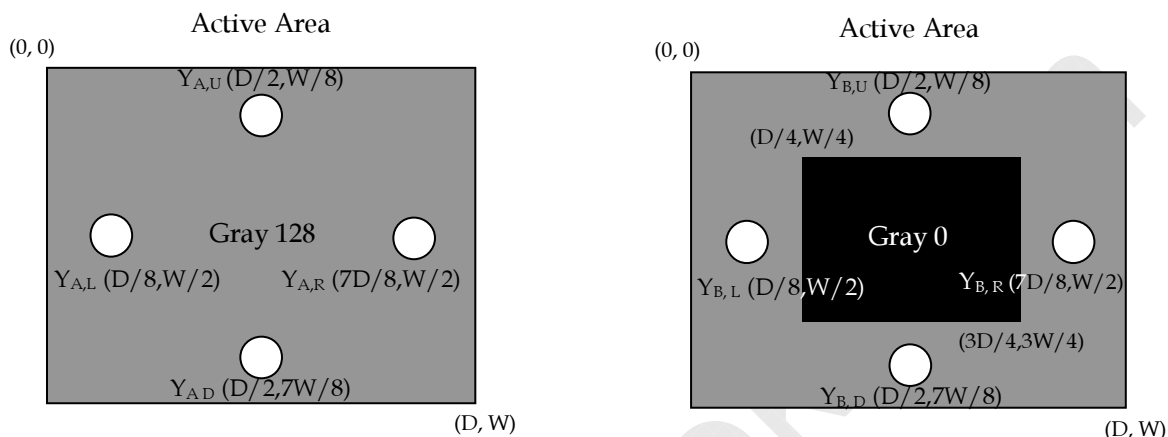

Y_A = Luminance of measured location without gray level 255 pattern (cd/m²)

Y_B = Luminance of measured location with gray level 255 pattern (cd/m²)

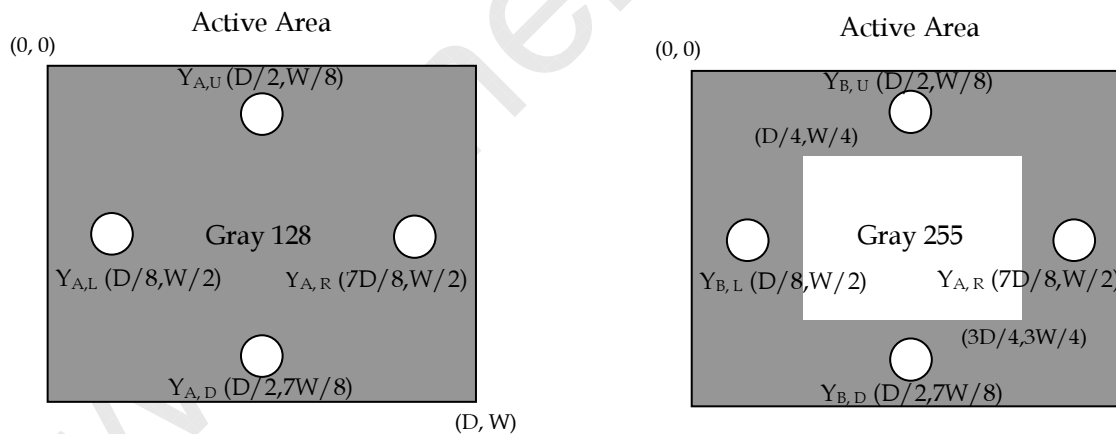

Note (6) Definition of White Variation (δW) :

Measure the luminance of gray level 255 at 5 points

$$\delta W = \text{Maximum [L (1), L (2), L (3), L (4), L (5)]} / \text{Minimum [L (1), L (2), L (3), L (4), L (5)]}$$

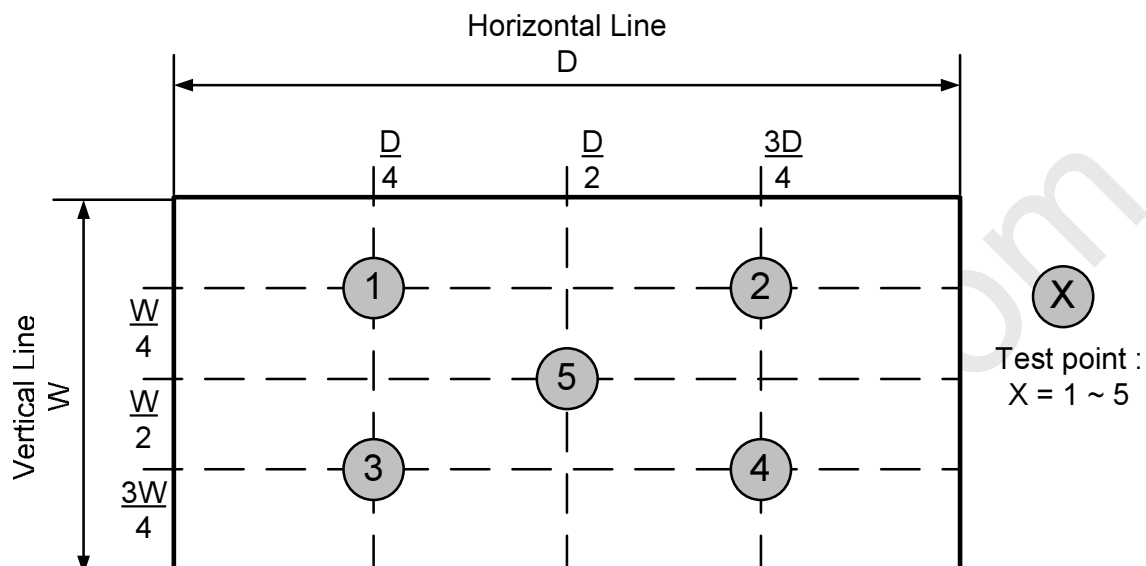

8. PRECAUTIONS

8.1 ASSEMBLY AND HANDLING PRECAUTIONS

- [1] Do not apply rough force such as bending or twisting to the module during assembly.
- [2] It is recommended to assemble or to install a module into the user's system in clean working areas. The dust and oil may cause electrical short or worsen the polarizer.
- [3] Do not apply pressure or impulse to the module to prevent the damage of LCD panel and Backlight.
- [4] Always follow the correct power-on sequence when the LCD module is turned on. This can prevent the damage and latch-up of the CMOS LSI chips.
- [5] Do not plug in or pull out the I/F connector while the module is in operation.
- [6] Do not disassemble the module.
- [7] Use a soft dry cloth without chemicals for cleaning, because the surface of polarizer is very soft and easily scratched.
- [8] Moisture can easily penetrate into LCD module and may cause the damage during operation.
- [9] When storing modules as spares for a long time, the following precaution is necessary.
 - [9.1] Do not leave the module in high temperature, and high humidity for a long time. It is highly recommended to store the module with temperature from 0 to 35°C at normal humidity without condensation.
 - [9.2] The module shall be stored in dark place. Do not store the TFT-LCD module in direct sunlight or fluorescent light.
- [10] When ambient temperature is lower than 10°C, the display quality might be reduced. For example, the response time will become slow, and the starting voltage of CCFL will be higher than that of room temperature.

8.2 SAFETY PRECAUTIONS

- [1] The startup voltage of a Backlight is approximately 1000 Volts. It may cause an electrical shock while assembling with the inverter. Do not disassemble the module or insert anything into the Backlight unit.
- [2] If the liquid crystal material leaks from the panel, it should be kept away from the eyes or mouth. In case of contact with hands, skin or clothes, it has to be washed away thoroughly with soap.
- [3] After the module's end of life, it is not harmful in case of normal operation and storage.

9. DEFINITION OF LABELS

9.1 MODULE LABEL

The barcode nameplate is pasted on each module as illustration, and its definitions are as following explanation.

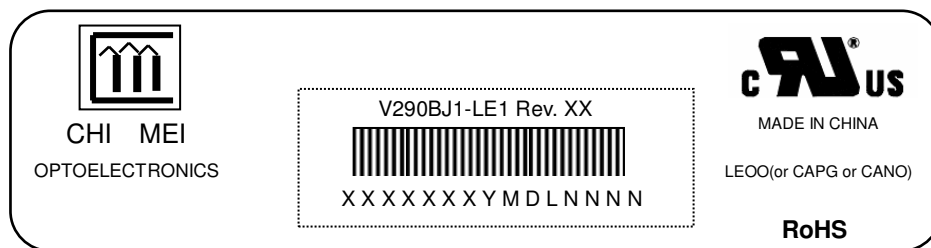

Model Name: V290BJ1-LE1

Revision: Rev. XX, for example: A0, A1... B1, B2... or C1, C2...etc.

Serial ID: XXXXXXXXYMDLNNNN

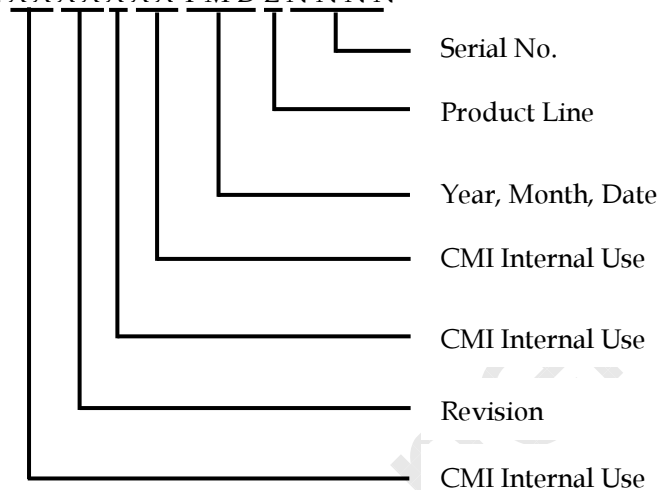

Serial ID includes the information as below :

Manufactured Date:

Year : 2010=0, 2011=1, 2012=2...etc.

Month : 1~9, A~C, for Jan. ~ Dec.

Day : 1~9, A~Y, for 1st to 31st, exclude I,O, and U.

Revision Code: Cover all the change

Serial No.: Manufacturing sequence of product

Product Line: 1 → Line1, 2 → Line 2, ...etc.

9.2 CARTON LABEL

The barcode nameplate is pasted on each box as illustration, and its definitions are as following explanation.

P.O. NO.	_____
Parts ID.	_____
Model Name	V290BJ1-LE1
Carton ID.	 XXXXXXXXXXXXXXXX
Quantities	____
Made In Taiwan (Made In China)	

(a) Model Name: V290BJ1- LE1

(b) Carton ID: X X X X X X Y M D X X X X

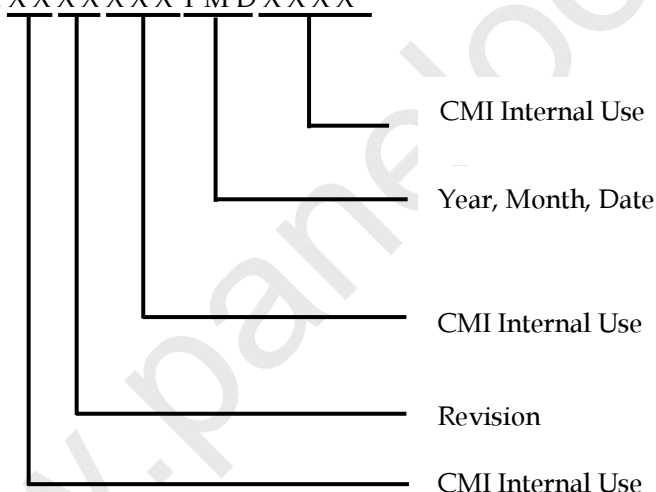

Serial ID includes the information as below :

Manufactured Date:

Year: 2010=0, 2011=1, 2012=2...etc.

Month: 1~9, A~C, for Jan. ~ Dec.

Day: 1~9, A~Y, for 1st to 31st, exclude I, O, and U.

Revision Code: Cover all the change

(c) Quantities: 7

10. PACKAGING

10.1 PACKAGING SPECIFICATIONS

- (1) 7 LCD TV modules / 1 Box
- (2) Box dimensions : 826(L)x376(W)x540(H)mm
- (3) Weight : Approx. 44 Kg (modules per carton)

10.2 PACKAGING METHOD

Packing methods are shown in following figures.

Sea / Land Transportation
(40ft Container)

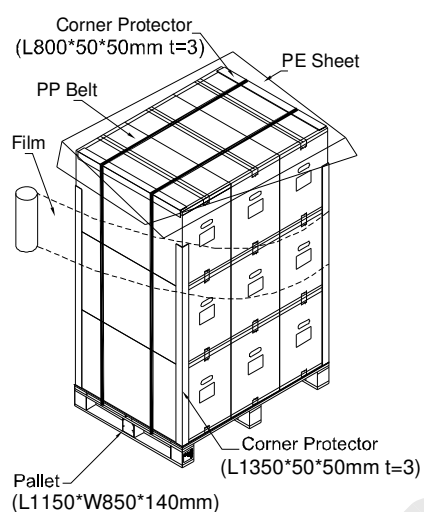

Air Transportation

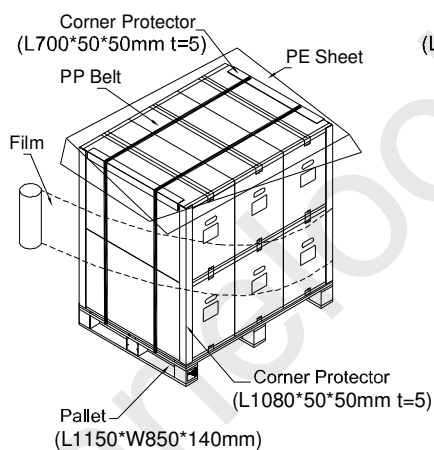

Sea / Land Transportation
(40ft HQ Container)

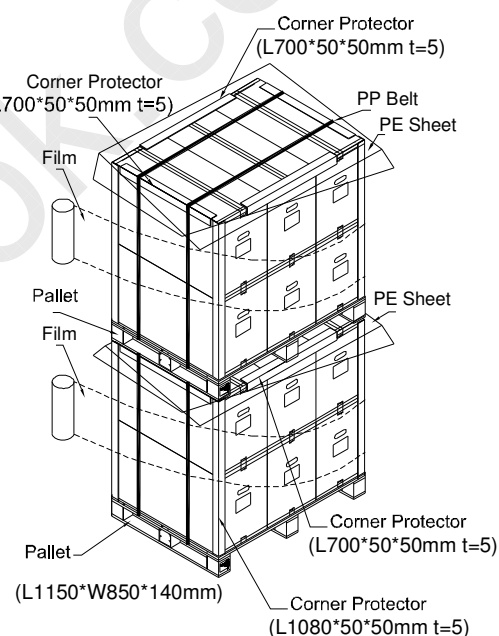

11. MECHANICAL CHARACTERISTIC

www.panelook.com