

TFT LCD Approval Specification

MODEL NO.: V315B1 - L01

Customer: _____ Approved by: _____ Note:
--

Approved By	TV Head Division	
	LY Chen	

Reviewed By	QA Dept.	Product Development Div.
	Tomy Chen	WT Lin

Prepared By	LCD TV Marketing and Product Management Div.	
	WY LI	Jim Ho

- CONTENTS -

REVISION HISTORY	3
1. GENERAL DESCRIPTION	4
1.1 OVERVIEW	
1.2 FEATURES	
1.3 APPLICATION	
1.4 GENERAL SPECIFICATIONS	
1.5 MECHANICAL SPECIFICATIONS	
2. ABSOLUTE MAXIMUM RATINGS	5
2.1 ABSOLUTE RATINGS OF ENVIRONMENT	
2.2 ELECTRICAL ABSOLUTE RATINGS	
2.2.1 TFT LCD MODULE	
2.2.2 BACKLIGHT UNIT	
3. ELECTRICAL CHARACTERISTICS	7
3.1 TFT LCD MODULE	
3.2 BACKLIGHT INVERTER UNIT	
3.2.1 CCFL(Cold Cathode Fluorescent Lamp) CHARACTERISTICS	
3.2.2 INVERTER CHARACTERISTICS	
3.2.3 INVERTER INTERFACE CHARACTERISTICS	
4. BLOCK DIAGRAM	12
4.1 TFT LCD MODULE	
5. INTERFACE PIN CONNECTION	13
5.1 TFT LCD MODULE	
5.2 BACKLIGHT UNIT	
5.3 INVERTER UNIT	
5.4 BLOCK DIAGRAM OF INTERFACE	
5.5 LVDS INTERFACE	
5.6 COLOR DATA INPUT ASSIGNMENT	
6. INTERFACE TIMING	19
6.1 INPUT SIGNAL TIMING SPECIFICATIONS	
6.2 POWER ON/OFF SEQUENCE	
7. OPTICAL CHARACTERISTICS	22
7.1 TEST CONDITIONS	
7.2 OPTICAL SPECIFICATIONS	
8. DEFINITION OF LABELS	26
8.1 CMO MODULE LABEL	
9. PACKAGING	27
9.1 PACKING SPECIFICATIONS	
9.2 PACKING METHOD	
10. PRECAUTIONS	29
10.1 ASSEMBLY AND HANDLING PRECAUTIONS	
10.2 SAFETY PRECAUTIONS	
11. REGULATORY STANDARDS	29
11.1 SAFETY	
12. MECHANICAL CHARACTERISTICS	30

REVISION HISTORY

Version	Date	Page (New)	Section	Description
Ver 2.0	Aug. 7,'06	All	All	Approval Specification was first issued.
Ver2.1	Oct. 12,'06	9	3.2.2	Update Power Consumption Value (W) : Typ. 120 → 110, Max. 134 → 120.
		30,31,32	12	Modify Mechanical Characteristics.
Ver3.0	Nov.08,'07	4	1.2	CR>20 → CR≥20
		10	3.2.3	Modify INVERTER INTERFACE CHARACTERISTICS.
		27,28	9	PACKAGING

1. GENERAL DESCRIPTION

1.1 OVERVIEW

V315B1- L01 is a 31.5" TFT Liquid Crystal Display module with 16-CCFL Backlight unit and 1ch-LVDS interface. This module supports 1366 x 768 WXGA format and can display true 16.7M colors (8-bit colors). The inverter module for backlight is built-in.

1.2 FEATURES

- High brightness (500 nits)
- Ultra-high contrast ratio (1500:1)
- Faster response time (gray to gray average 6.5ms)
- High color saturation NTSC 72%
- Ultra wide viewing angle : 176(H)/176(V) (CR \geq 20) with Super MVA technology
- DE (Data Enable) only mode
- LVDS (Low Voltage Differential Signaling) interface
- 180 degree rotation display (option)
- Color reproduction (nature color)
- Low color shift function

1.3 APPLICATION

- TFT LCD TVs
- Multi-Media Display

1.4 GENERAL SPECIFICATIONS

Item	Specification	Unit	Note
Active Area	697.6845 (H) x 392.256 (V) (31.51" diagonal)	mm	(1)
Bezel Opening Area	703.8 (H) x 398.4 (V)	mm	
Driver Element	a-si TFT active matrix	-	
Pixel Number	1366 x R.G.B. x 768	pixel	
Pixel Pitch (Sub Pixel)	0.17025(H) x 0.51075 (V)	mm	
Pixel Arrangement	RGB vertical stripe	-	
Display Colors	16.7M	color	
Display Operation Mode	Transmissive mode / Normally black	-	
Surface Treatment	Anti-Glare coating (Haze 25%),Hard coating (3H)	-	

1.5 MECHANICAL SPECIFICATIONS

Item	Min.	Typ.	Max.	Unit	Note	
Module Size	Horizontal(H)	759	760	761	mm	(1)
	Vertical(V)	449	450	451	mm	(1)
	Depth(D)	36.95	37.95	38.95	mm	To PCB cover
	Depth(D)	46.4	47.4	48.4	mm	To inverter cover
Weight	6300	6500	6700	g		

Note (1) Please refer to the attached drawings for more information of front and back outline dimensions.

2. ABSOLUTE MAXIMUM RATINGS

2.1 ABSOLUTE RATINGS OF ENVIRONMENT

Item	Symbol	Value		Unit	Note
		Min.	Max.		
Storage Temperature	T _{ST}	-20	+60	°C	(1)
Operating Ambient Temperature	T _{OP}	0	+50	°C	(1), (2)
Shock (Non-Operating)	S _{NOF}	-	50	G	(3), (5)
Vibration (Non-Operating)	V _{NOF}	-	1.0	G	(4), (5)

Note (1) Temperature and relative humidity range is shown in the figure below.

- (a) 90 %RH Max. ($T_a \leq 40$ °C).
- (b) Wet-bulb temperature should be 39 °C Max. ($T_a > 40$ °C).
- (c) No condensation.

Note (2) The maximum operating temperature is based on the test condition that the surface temperature of display area is less than or equal to 65 °C with LCD module alone in a temperature controlled chamber. Thermal management should be considered in final product design to prevent the surface temperature of display area from being over 65 °C. The range of operating temperature may degrade in case of improper thermal management in final product design.

Note (3) 11 ms, half sine wave, 1 time for $\pm X$, $\pm Y$, $\pm Z$.

Note (4) 10 ~ 200 Hz, 10 min, 1 time each X, Y, Z.

Note (5) At testing Vibration and Shock, the fixture in holding the module has to be hard and rigid enough so that the module would not be twisted or bent by the fixture.

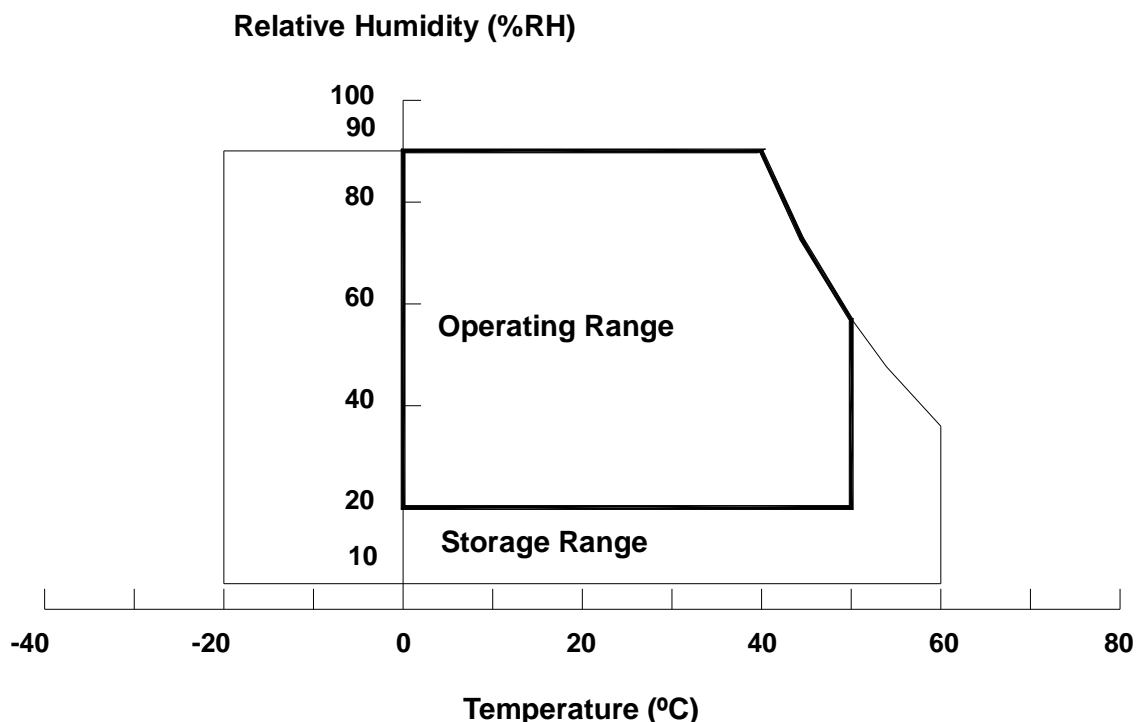

2.2 ELECTRICAL ABSOLUTE RATINGS

2.2.1 TFT LCD MODULE

Item	Symbol	Value		Unit	Note
		Min.	Max.		
Power Supply Voltage	V _{CC}	-0.3	6.0	V	(1)
Input Signal Voltage	V _{IN}	-0.3	3.6	V	

2.2.2 BACKLIGHT UNIT

Item	Symbol	Value		Unit	Note
		Min.	Max.		
Lamp Voltage	V _W	—	3000	V _{RMS}	
Power Supply Voltage	V _{BL}	0	30	V	(1)
Control Signal Level	—	-0.3	7	V	(1), (3)

Note (1) Permanent damage to the device may occur if maximum values are exceeded. Functional operation should be restricted to the conditions described under normal operating conditions.

Note (2) No moisture condensation or freezing.

Note (3) The control signals includes Backlight On/Off Control, I_PWM Control, E_PWM Control and ERR signal for inverter status output.

3. ELECTRICAL CHARACTERISTICS

3.1 TFT LCD MODULE

Ta = 25 ± 2 °C

Parameter	Symbol	Value			Unit	Note	
		Min.	Typ.	Max.			
Power Supply Voltage	V _{CC}	4.5	5.0	5.5	V	(1)	
Power Supply Ripple Voltage	V _{RP}	-	-	100	mV		
Rush Current	I _{RUSH}	-	-	4	A	(2)	
Power Supply Current	White	I _{CC}	-	1.60	2.2	A	(3)
	Black		-	0.90	-	A	
	Vertical Stripe		-	1.40	-	A	
LVDS Interface	Differential Input High Threshold Voltage	V _{LVTH}	-	-	+100	mV	
	Differential Input Low Threshold Voltage	V _{LVTL}	-100	-	-	mV	
	Common Input Voltage	V _{LVC}	1.125	1.25	1.375	V	
	Terminating Resistor	R _T	-	100	-	ohm	
CMOS interface	Input High Threshold Voltage	V _{IH}	2.7	-	3.3	V	
	Input Low Threshold Voltage	V _{IL}	0	-	0.7	V	

Note (1) The module should be always operated within above ranges.

Note (2) Measurement Conditions:

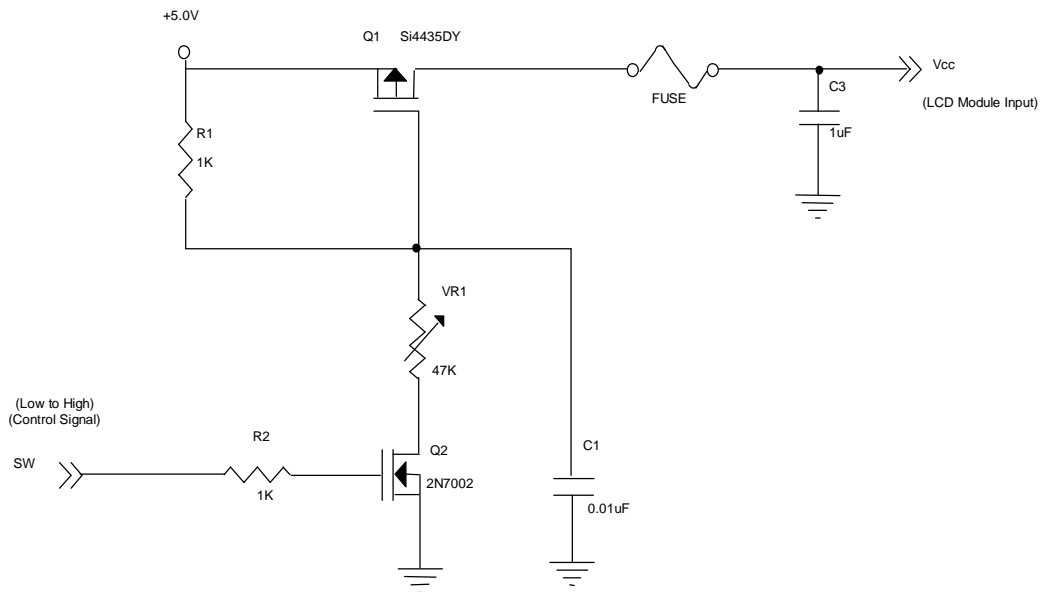

Vcc rising time is 470us

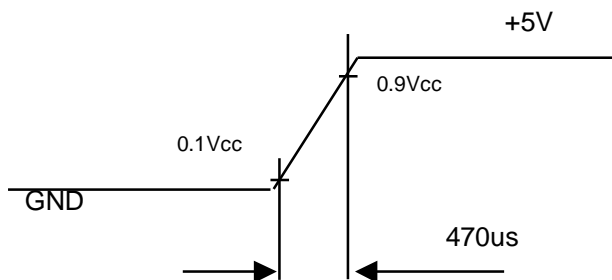

Note (3) The specified power supply current is under the conditions at $V_{CC} = 5\text{ V}$, $T_a = 25 \pm 2\text{ }^\circ\text{C}$, $f_v = 60\text{ Hz}$, whereas a power dissipation check pattern below is displayed.

a. White Pattern



Active Area

b. Black Pattern



Active Area

c. Vertical Stripe Pattern

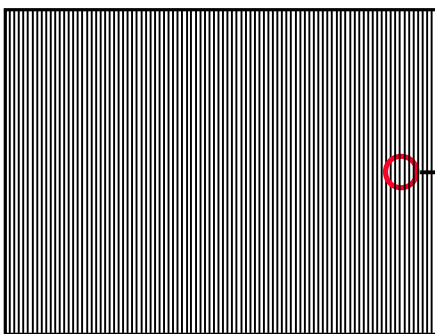

Active Area

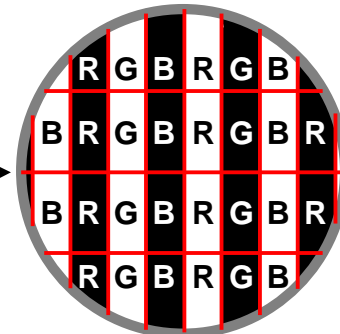

3.2 BACKLIGHT INVERTER UNIT

3.2.1 CCFL (Cold Cathode Fluorescent Lamp) CHARACTERISTICS ($T_a = 25 \pm 2\text{ }^\circ\text{C}$)

Parameter	Symbol	Value			Unit	Note
		Min.	Typ.	Max.		
Lamp Voltage	V_W	-	1250	-	V_{RMS}	$I_L = 5.2\text{mA}$
Lamp Current	I_L	4.7	5.2	5.7	mA_{RMS}	(1)
Lamp Starting Voltage	V_S	-	-	2450	V_{RMS}	(2), $T_a = 0\text{ }^\circ\text{C}$
		-	-	2360	V_{RMS}	(2), $T_a = 25\text{ }^\circ\text{C}$
Operating Frequency	F_O	40	-	70	KHZ	(3)
Lamp Life Time	L_{BL}	50,000		-	Hrs	(4)

3.2.2 INVERTER CHARACTERISTICS (Ta = 25 ± 2 °C)

Parameter	Symbol	Value			Unit	Note
		Min.	Typ.	Max.		
Power Consumption	P _{BL}	-	110	120	W	(5),(6), I _L = 5.2mA
Input Voltage	V _{BL}	22.8	24	25.2	V _{DC}	
Input Current	I _{BL}	-	5.0	-	A	Non Dimming
Input Ripple Noise	-	-	-	500	mV _{P-P}	V _{BL} =22.8V
Backlight Turn on Voltage	V _{BS}	2450	-	-	V _{RMS}	Ta = 0 °C
		2360	-	-	V _{RMS}	Ta = 25 °C
Oscillating Frequency	F _W	55	58	61	kHz	
Dimming frequency	F _B	150	160	170	Hz	
Minimum Duty Ratio	D _{MIN}	-	20	-	%	

Note (1) Lamp current is measured by utilizing high frequency current meters as shown below:

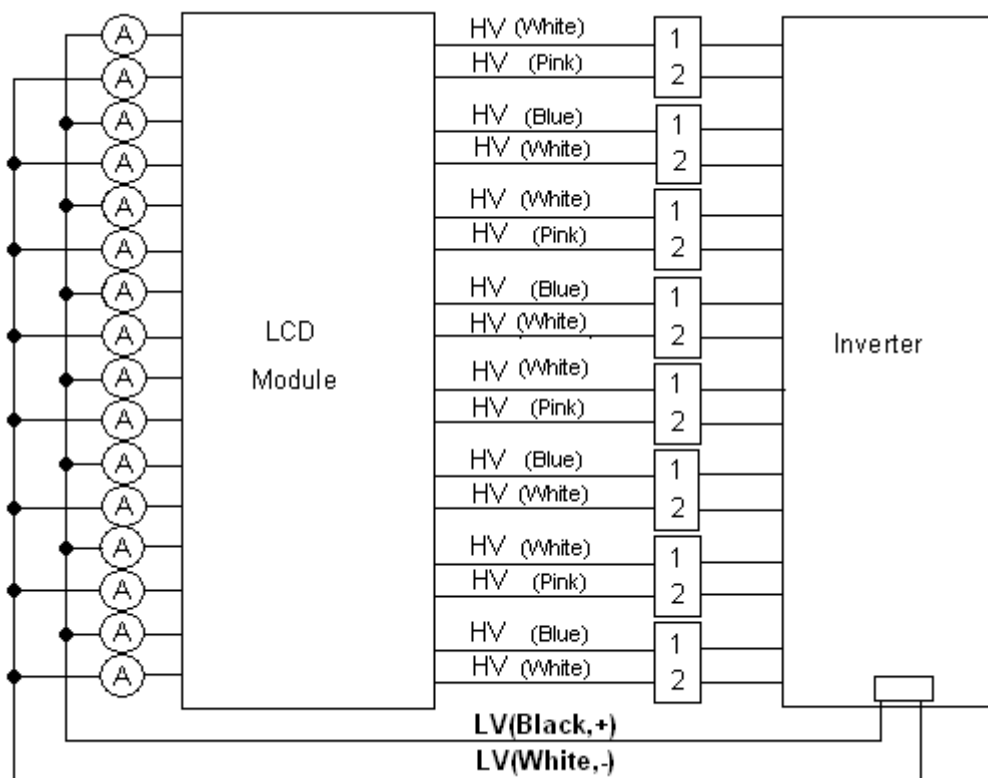

Note (2) The lamp starting voltage V_S should be applied to the lamp for more than 1 second under starting up duration. Otherwise the lamp could not be lighted on completed.

Note (3) The lamp frequency may produce interference with horizontal synchronous frequency of the display input signals, and it may result in line flow on the display. In order to avoid interference, the lamp frequency should be detached from the horizontal synchronous frequency and its harmonics as far as possible.

Note (4) The life time of a lamp is defined as when the brightness is larger than 50% of its original value and the effective discharge length is longer than 80% of its original length (Effective discharge length is defined as an area that has equal to or more than 70% brightness compared to the brightness at the center point of lamp.) as the time in which it continues to operate under the condition at Ta = 25 ± 2 °C and I_L = 4.7 ~ 5.7 mA_{RMS}.

Note (5) The power supply capacity should be higher than the total inverter power consumption P_{BL} . Since the pulse width modulation (PWM) mode was applied for backlight dimming, the driving current changed as PWM duty on and off. The transient response of power supply should be considered for the changing loading when inverter dimming.

Note (6) The measurement condition of Max. value is based on 31.5" backlight unit under input voltage 24V, average lamp current 5.5 mA and lighting 30 minutes later.

3.2.3 INVERTER INTERFACE CHARACTERISTICS

No	ITEM	SYMBOL	TEST CONDITION	MIN	TYPE	MAX	UNIT	NOTE ⁽¹⁻²⁾
1	Error Signal	ERR	—	—	—	—	—	(Note 2)
2	On/Off Control Voltage	ON	—	2.0	—	5.0	V	
		OFF		0	—	0.8	V	
3	Internal PWM Control Voltage	MAX	—	3.15	3.3	3.45	V	Maximum Duty Ratio
		MIN		—	0	—	V	Minimum Duty Ratio
4	External PWM Control Voltage	HI	—	2.0	—	5.0	V	ON Duration
		LO		—	0	—	0.8	V
5	VBL Rising Time	Tr1	—	30	—	50	ms	
6	VBL Falling Time	Tf1	—	30	—	50	ms	
7	Control Signal Rising Time	Tr	—	—	—	100	ms	
8	Control Signal Falling Time	Tf	—	—	—	100	ms	
9	PWM Signal Rising Time	T _{PWMR}	—	—	—	50	us	
10	PWM Signal Falling Time	T _{PWMF}	—	—	—	50	us	
11	Input impedance	R _{IN}	—	1	—	—	MΩ	
12	PWM Delay Time	T _{PWM}	—	100	—	300	mS	
13	BLON Delay Time	T _{on}	—	300	—	500	mS	
14	BLON Off Time	T _{OFF}	—	300	—	500	mS	

Note (1) The power sequence and control signal timing are shown as the following figure 1.

Note (2) When inverter protective function is triggered, ERR will output open collector status; In normal operation, the signal of ERR will output a low level voltage.

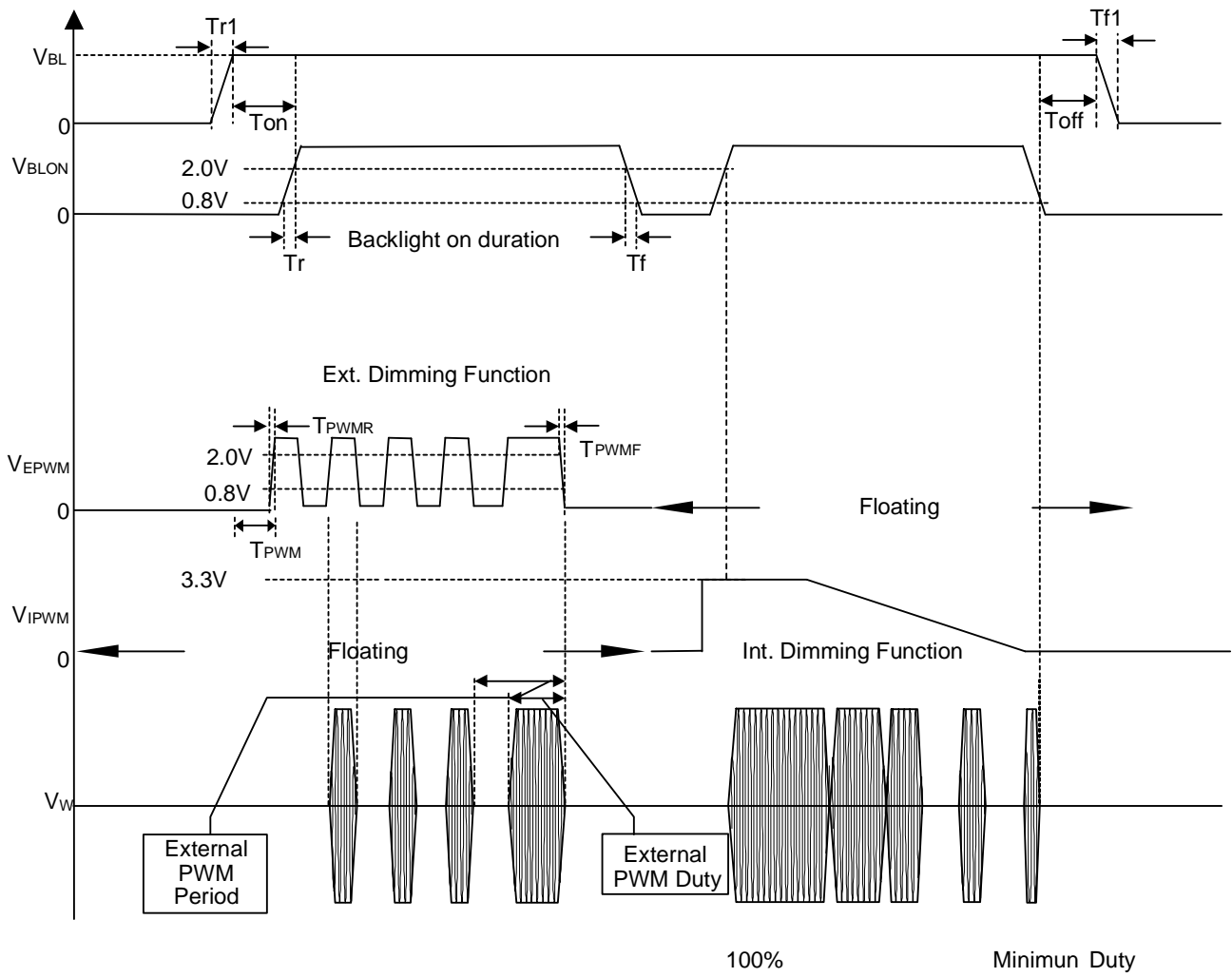
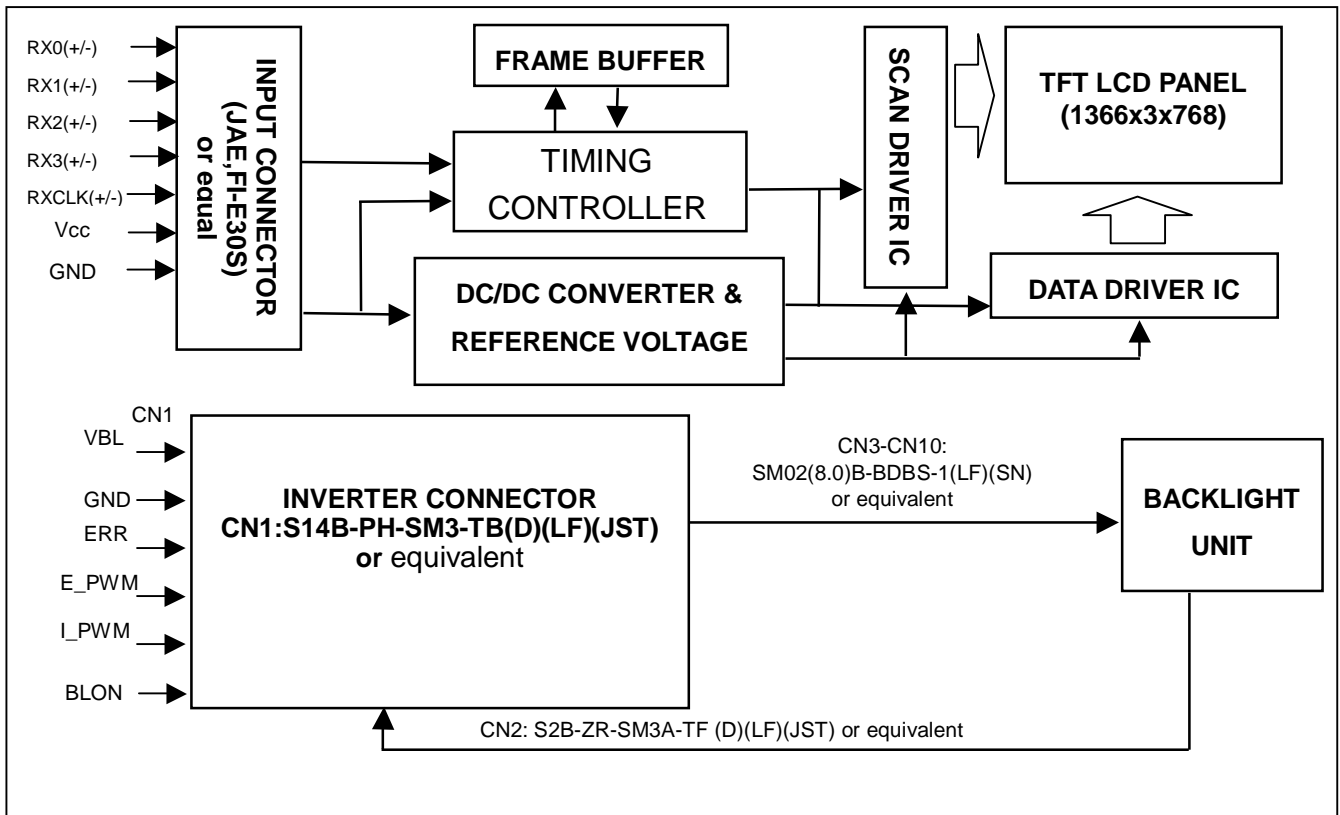

Figure 1

4. BLOCK DIAGRAM

4.1 TFT LCD MODULE



5. INTERFACE PIN CONNECTION

5.1 TFT LCD MODULE

CNF1 Connector Pin Assignment

Pin No.	Symbol	Description	Note
1	ODSEL	Overdrive Lookup Table Selection	(2)
2	RPF	Display Rotation	(3)
3	NC	No connection	(4)
4	GND	Ground	
5	RX0-	Negative transmission data of pixel 0	
6	RX0+	Positive transmission data of pixel 0	
7	GND	Ground	
8	RX1-	Negative transmission data of pixel 1	
9	RX1+	Positive transmission data of pixel 1	
10	GND	Ground	
11	RX2-	Negative transmission data of pixel 2	
12	RX2+	Positive transmission data of pixel 2	
13	GND	Ground	
14	RXCLK-	Negative of clock	
15	RXCLK+	Positive of clock	
16	GND	Ground	
17	RX3-	Negative transmission data of pixel 3	
18	RX3+	Positive transmission data of pixel 3	
19	GND	Ground	
20	NC	No connection	(4)
21	SELLVDS	Select LVDS data format	(5)
22	NC	No connection	(4)
23	GND	Ground	
24	GND	Ground	
25	GND	Ground	
26	VCC	Power supply: +5V	
27	VCC	Power supply: +5V	
28	VCC	Power supply: +5V	
29	VCC	Power supply: +5V	
30	VCC	Power supply: +5V	

Note (1) Connector Part No.: FI-E30S(JAE) or compatible

Note (2) Overdrive lookup table selection. The Overdrive lookup table should be selected in accordance to the frame rate to optimize image quality.

ODSEL	Note
L or Open	Lookup table was optimized for 60 Hz frame rate.
H	Lookup table was optimized for 50 Hz frame rate.

Note (3) Low or open: normal display (default), High : display with 180 degree rotation

Note (4) Reserved for internal use. Left it open.

Note (5) Ground: JEIDA, High or OPEN: Normal LVDS format

Please refer to 5.5 LVDS INTERFACE (Page 17)

5.2 BACKLIGHT UNIT

The pin configuration for the housing and leader wire is shown in the table below.

CN3-CN10 (Housing): BDBR-03(4.0)V-1S or equivalent

Pin No.	Symbol	Description	Wire Color
1	HV	High Voltage	White
2	HV	High Voltage	Pink
3	HV	High Voltage	Blue
4	HV	High Voltage	White

Note (1) The backlight interface housing for high voltage side is a model BDBR-03(4.0)V-1S, manufactured by JST or equivalent. The mating header on inverter part number is SM02(8.0)B-BDBS-1-TB(LF)

CN2 (Housing): ZHR-2 (JST) or equivalent

Pin No.	Symbol	Description	Wire Color
1	LV	Low Voltage (+)	Black
2	LV	Low Voltage (-)	White

Note (2) The backlight interface housing and return cable for low voltage side is a model ZHR-2, manufactured by JST or equivalent. The mating header on inverter part number is S2B-ZR-SM3A-TF(D)(LF) or equivalent.

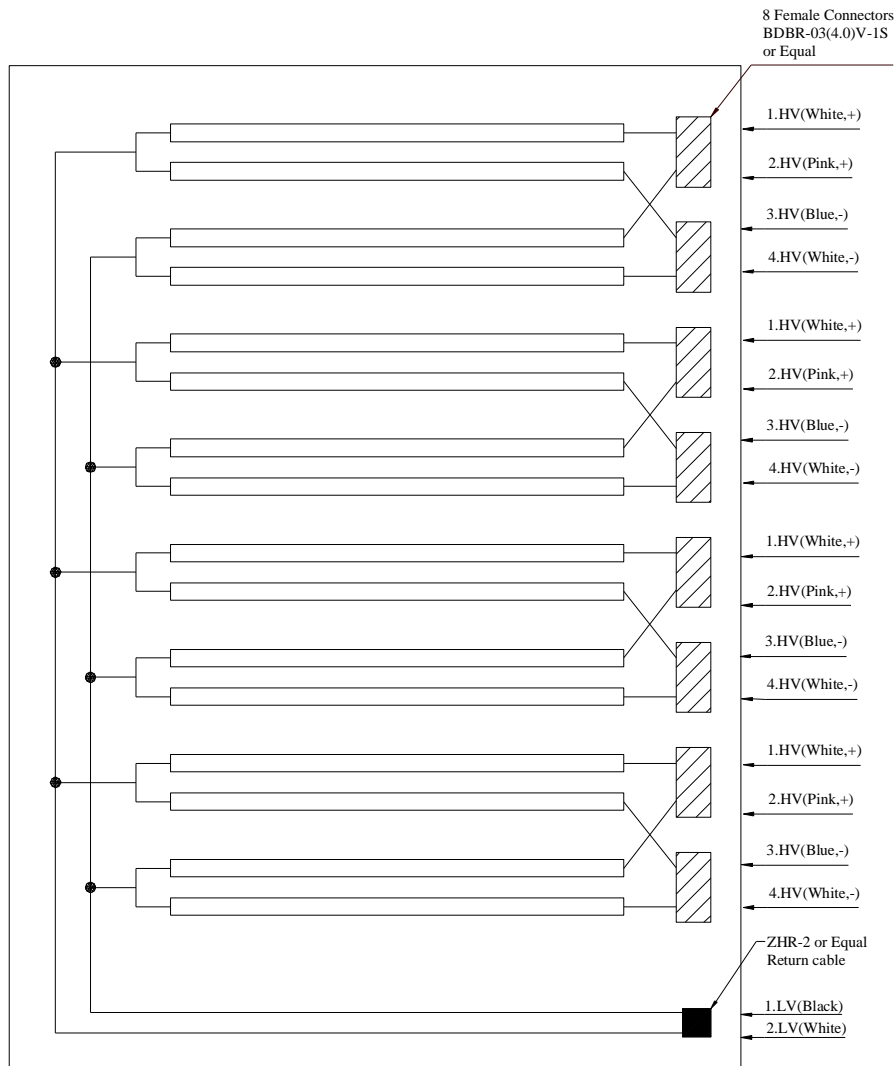

5.3 INVERTER UNIT

CN1(Header): S14B-PH-SM3-TB(D)(LF)(JST) or equivalent..

Pin No.	Symbol	Description
1	VBL	+24V Power input
2		
3		
4		
5		
6	GND	Ground
7		
8		
9		
10		
11	ERR	Normal (GND) Abnormal (open collector)
12	BLON	Backlight on/off control
13	I_PWM	Internal PWM control signal
14	E_PWM	External PWM control signal

Notice:

#PIN 13:Analog Dimming Control (Use Pin 13) : 0V~3.3V and Pin 14 must open.

#PIN 14:PWM Dimming Control (Use Pin 14) : Pin 13 must open.

#Pin 13(I_PWM) and Pin 14(E_PWM) can not open in same period.

CN2(Header): S2B-ZR-SM3A-TF(D)(LF)(JST) or equivalent

Pin No.	Symbol	Description
1	CCFL COLD	CCFL low voltage (+)
2	CCFL COLD	CCFL low voltage (-)

CN3-CN10 (Header): SM02(8.0)B-BDBS-1(LF)(SN) or equivalent.

Pin No.	Symbol	Description
1	CCFL HOT	CCFL high voltage
2	CCFL HOT	CCFL high voltage

5.4 BLOCK DIAGRAM OF INTERFACE

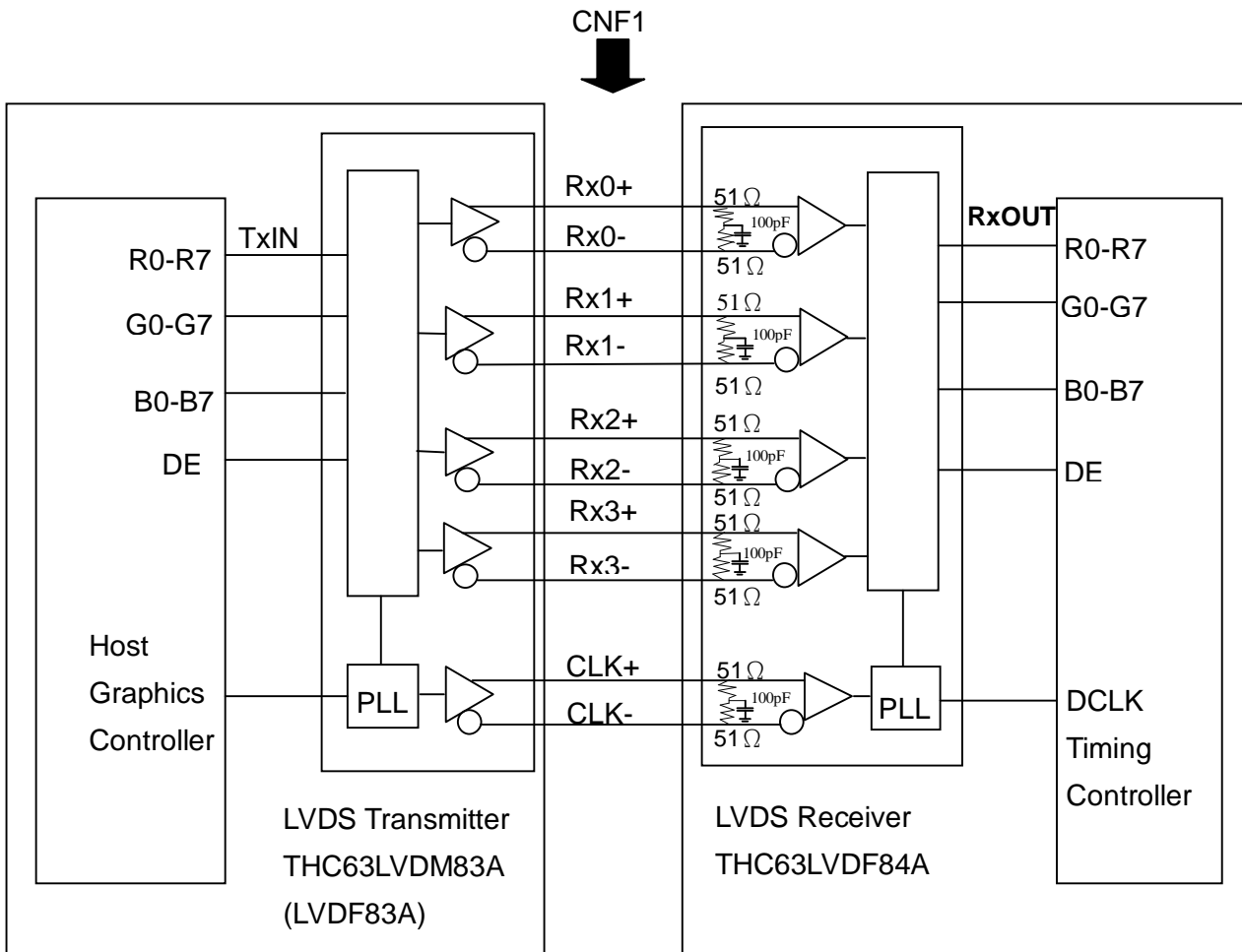

R0~R7 : Pixel R Data ,
 G0~G7 : Pixel G Data ,
 B0~B7 : Pixel B Data ,
 DE : Data enable signal

Note (1) The system must have the transmitter to drive the module.

Note (2) LVDS cable impedance shall be 50 ohms per signal line or about 100 ohms per twist-pair line when it is used differentially.

5.5 LVDS INTERFACE

	SIGNAL		TRANSMITTER THC63LVDM83A		INTERFACE CONNECTOR		RECEIVER THC63LVDF84A		TFT CONTROL INPUT			
	SELLVDS= H or OPEN	SELLVDS= L	PIN	INPUT	Host	TFT-LCD	PIN	OUTPUT	SELLVDS= H or OPEN	SELLVDS =L		
24 bit	R0	R2	51	TxIN0	TA OUT0+	Rx 0+	27	Rx OUT0	R0	R2		
	R1	R3	52	TxIN1			29	Rx OUT1	R1	R3		
	R2	R4	54	TxIN2			30	Rx OUT2	R2	R4		
	R3	R5	55	TxIN3			32	Rx OUT3	R3	R5		
	R4	R6	56	TxIN4			33	Rx OUT4	R4	R6		
	R5	R7	3	TxIN6			TA OUT0-	Rx 0-	35	Rx OUT6	R5	R7
	G0	G2	4	TxIN7					37	Rx OUT7	G0	G2
	G1	G3	6	TxIN8	38	Rx OUT8			G1	G3		
	G2	G4	7	TxIN9	TA OUT1+	Rx 1+	39	Rx OUT9	G2	G4		
	G3	G5	11	TxIN12			43	Rx OUT12	G3	G5		
	G4	G6	12	TxIN13			45	Rx OUT13	G4	G6		
	G5	G7	14	TxIN14			46	Rx OUT14	G5	G7		
	B0	B2	15	TxIN15			TA OUT1-	Rx 1-	47	Rx OUT15	B0	B2
	B1	B3	19	TxIN18	51	Rx OUT18			B1	B3		
	B2	B4	20	TxIN19	53	Rx OUT19			B2	B4		
	B3	B5	22	TxIN20	TA OUT2+	Rx 2+	54	Rx OUT20	B3	B5		
	B4	B6	23	TxIN21			55	Rx OUT21	B4	B6		
	B5	B7	24	TxIN22			1	Rx OUT22	B5	B7		
	DE	DE	30	TxIN26			6	Rx OUT26	DE	DE		
	R6	R0	50	TxIN27	TA OUT2-	Rx 2-	7	Rx OUT27	R6	R0		
	R7	R1	2	TxIN5			34	Rx OUT5	R7	R1		
	G6	G0	8	TxIN10	TA OUT3+	Rx 3+	41	Rx OUT10	G6	G0		
	G7	G1	10	TxIN11			42	Rx OUT11	G7	G1		
	B6	B0	16	TxIN16			49	Rx OUT16	B6	B0		
	B7	B1	18	TxIN17			50	Rx OUT17	B7	B1		
	RSVD 1	RSVD 1	25	TxIN23			2	Rx OUT23	NC	NC		
	RSVD 2	RSVD 2	27	TxIN24			TA OUT3-	Rx 3-	3	Rx OUT24	NC	NC
	RSVD 3	RSVD 3	28	TxIN25					5	Rx OUT25	NC	NC
DCLK		31	TxCLK IN	TxCLK OUT+	RxCLK IN+	26	RxCLK	DCLK				
				TxCLK OUT-	RxCLK IN-		OUT					

R0~R7: Pixel R Data (7; MSB, 0; LSB)

G0~G7: Pixel G Data (7; MSB, 0; LSB)

B0~B7: Pixel B Data (7; MSB, 0; LSB)

DE: Data enable signal

Notes(1) RSVD(reserved)pins on the transmitter shall be "H" or ("L" or OPEN)

5.6 COLOR DATA INPUT ASSIGNMENT

The brightness of each primary color (red, green and blue) is based on the 8-bit gray scale data input for the color. The higher the binary input, the brighter the color. The table below provides the assignment of color versus data input.

Color		Data Signal																							
		Red								Green								Blue							
		R7	R6	R5	R4	R3	R2	R1	R0	G7	G6	G5	G4	G3	G2	G1	G0	B7	B6	B5	B4	B3	B2	B1	B0
Basic Colors	Black	0	0	0	0	0	0	0	0	0	0	0	0	0	0	0	0	0	0	0	0	0	0	0	
	Red	1	1	1	1	1	1	1	1	0	0	0	0	0	0	0	0	0	0	0	0	0	0	0	
	Green	0	0	0	0	0	0	0	0	1	1	1	1	1	1	1	1	0	0	0	0	0	0	0	
	Blue	0	0	0	0	0	0	0	0	0	0	0	0	0	0	0	0	1	1	1	1	1	1	1	
	Cyan	0	0	0	0	0	0	0	0	1	1	1	1	1	1	1	1	1	1	1	1	1	1	1	
	Magenta	1	1	1	1	1	1	1	1	0	0	0	0	0	0	0	0	1	1	1	1	1	1	1	
	Yellow	1	1	1	1	1	1	1	1	1	1	1	1	1	1	1	1	0	0	0	0	0	0	0	
	White	1	1	1	1	1	1	1	1	1	1	1	1	1	1	1	1	1	1	1	1	1	1	1	
Gray Scale Of Red	Red(0) / Dark	0	0	0	0	0	0	0	0	0	0	0	0	0	0	0	0	0	0	0	0	0	0		
	Red(1)	0	0	0	0	0	0	0	1	0	0	0	0	0	0	0	0	0	0	0	0	0	0		
	Red(2)	0	0	0	0	0	0	1	0	0	0	0	0	0	0	0	0	0	0	0	0	0	0		
	:	:	:	:	:	:	:	:	:	:	:	:	:	:	:	:	:	:	:	:	:	:	:		
	:	:	:	:	:	:	:	:	:	:	:	:	:	:	:	:	:	:	:	:	:	:	:		
	Red(253)	1	1	1	1	1	1	0	1	0	0	0	0	0	0	0	0	0	0	0	0	0	0		
	Red(254)	1	1	1	1	1	1	1	0	0	0	0	0	0	0	0	0	0	0	0	0	0	0		
	Red(255)	1	1	1	1	1	1	1	1	0	0	0	0	0	0	0	0	0	0	0	0	0	0		
Gray Scale Of Green	Green(0) / Dark	0	0	0	0	0	0	0	0	0	0	0	0	0	0	0	0	0	0	0	0	0	0		
	Green(1)	0	0	0	0	0	0	0	0	0	0	0	0	0	0	1	0	0	0	0	0	0	0		
	Green(2)	0	0	0	0	0	0	0	0	0	0	0	0	0	1	0	0	0	0	0	0	0	0		
	:	:	:	:	:	:	:	:	:	:	:	:	:	:	:	:	:	:	:	:	:	:	:		
	:	:	:	:	:	:	:	:	:	:	:	:	:	:	:	:	:	:	:	:	:	:	:		
	Green(253)	0	0	0	0	0	0	0	0	1	1	1	1	1	1	0	1	0	0	0	0	0	0		
	Green(254)	0	0	0	0	0	0	0	0	1	1	1	1	1	1	1	0	0	0	0	0	0	0		
	Green(255)	0	0	0	0	0	0	0	0	1	1	1	1	1	1	1	1	0	0	0	0	0	0		
Gray Scale Of Blue	Blue(0) / Dark	0	0	0	0	0	0	0	0	0	0	0	0	0	0	0	0	0	0	0	0	0	0		
	Blue(1)	0	0	0	0	0	0	0	0	0	0	0	0	0	0	0	0	0	0	0	0	0	1		
	Blue(2)	0	0	0	0	0	0	0	0	0	0	0	0	0	0	0	0	0	0	0	0	0	1		
	:	:	:	:	:	:	:	:	:	:	:	:	:	:	:	:	:	:	:	:	:	:	:		
	:	:	:	:	:	:	:	:	:	:	:	:	:	:	:	:	:	:	:	:	:	:	:		
	Blue(253)	0	0	0	0	0	0	0	0	0	0	0	0	0	0	0	0	1	1	1	1	1	0		
	Blue(254)	0	0	0	0	0	0	0	0	0	0	0	0	0	0	0	0	1	1	1	1	1	0		
	Blue(255)	0	0	0	0	0	0	0	0	0	0	0	0	0	0	0	0	1	1	1	1	1	1		

Note (1) 0: Low Level Voltage, 1: High Level Voltage

6. INTERFACE TIMING

6.1 INPUT SIGNAL TIMING SPECIFICATIONS

The input signal timing specifications are shown as the following table and timing diagram.

Signal	Item	Symbol	Min.	Typ.	Max.	Unit	Note
LVDS Receiver Clock	Frequency	1/Tc	60	86	88	MHZ	
	Input cycle to cycle jitter	Trcl	-	-	200	ps	
LVDS Receiver Data	Setup Time	Tlvsu	600	-	-	ps	
	Hold Time	Tlvhd	600	-	-	ps	
Vertical Active Display Term	Frame Rate	Fr5	47	50	53	Hz	(2)
		Fr6	57	60	63	Hz	
	Total	Tv	778	795	888	Th	Tv=Tvd+Tvb
	Display	Tvd	768	768	768	Th	-
	Blank	Tvb	10	27	120	Th	-
Horizontal Active Display Term	Total	Th	1442	1798	1936	Tc	Th=Thd+Thb
	Display	Thd	1366	1366	1366	Tc	-
	Blank	Thb	76	432	570	Tc	-

Note (1) Since this module is operated in DE only mode, Hsync and Vsync input signals should be set to low logic level. Otherwise, this module would operate abnormally.

(2) Please refer to 5.1 for detail information.

INPUT SIGNAL TIMING DIAGRAM

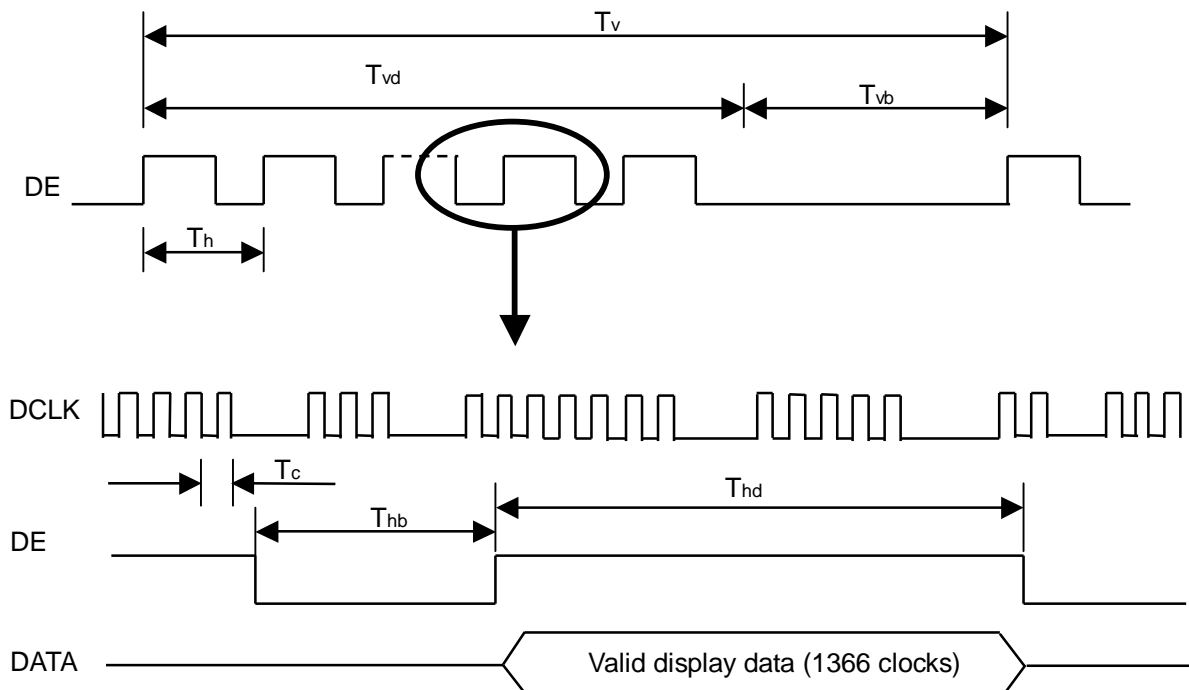

LVDS RECEIVER INTERFACE TIMING DIAGRAM

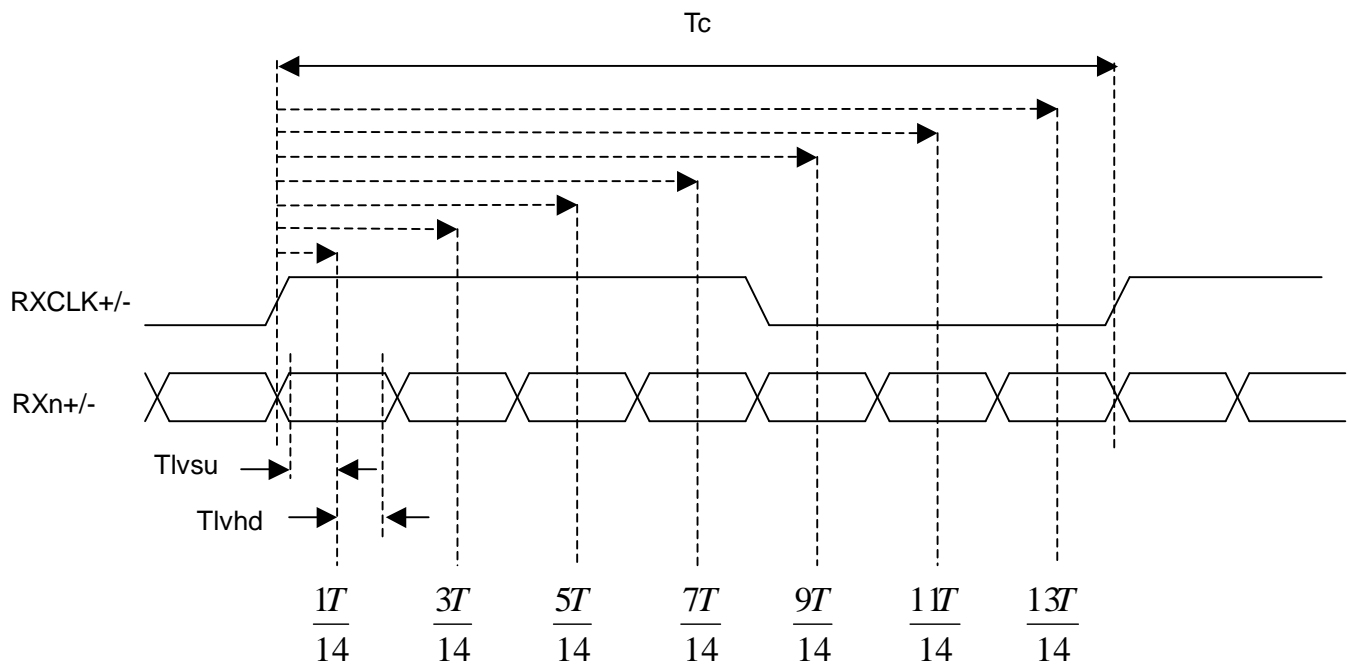

6.2 POWER ON/OFF SEQUENCE

To prevent a latch-up or DC operation of LCD module, the power on/off sequence should be as the diagram below.

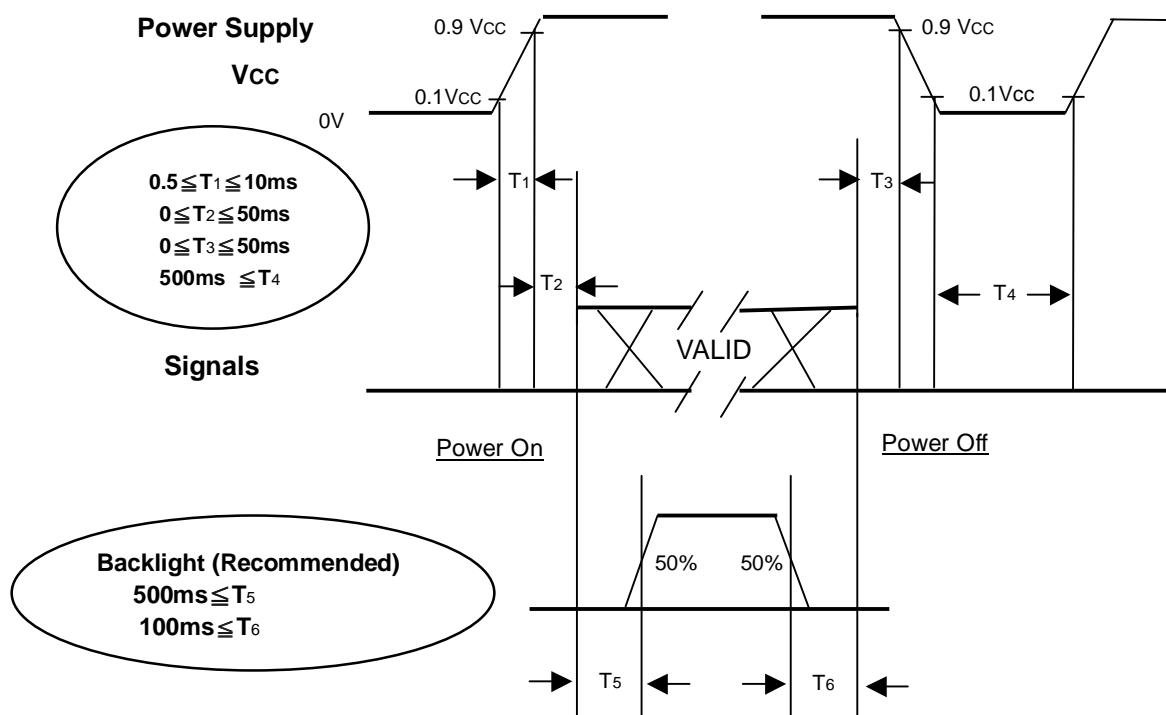

Power ON/OFF Sequence

Note (1) The supply voltage of the external system for the module input should follow the definition of Vcc.

Note (2) Apply the lamp voltage within the LCD operation range. When the backlight turns on before the LCD operation or the LCD turns off before the backlight turns off, the display may momentarily become abnormal screen.

Note (3) In case of Vcc is in off level, please keep the level of input signals on the low or high impedance.

Note (4) T4 should be measured after the module has been fully discharged between power off and on period.

Note (5) Interface signal shall not be kept at high impedance when the power is on.

7. OPTICAL CHARACTERISTICS

7.1 TEST CONDITIONS

Item	Symbol	Value	Unit
Ambient Temperature	Ta	25±2	°C
Ambient Humidity	Ha	50±10	%RH
Supply Voltage	V _{CC}	5.0	V
Input Signal	According to typical value in "3. ELECTRICAL CHARACTERISTICS"		
Lamp Current	I _L	5.2 ± 0.5	mA
Oscillating Frequency (Inverter)	F _w	58±3	KHz
Frame rate		60	Hz

7.2 OPTICAL SPECIFICATIONS

The relative measurement methods of optical characteristics are shown in 7.2. The following items should be measured under the test conditions described in 7.1 and stable environment shown in Note (6).

Item	Symbol	Condition	Min.	Typ.	Max.	Unit	Note	
Contrast Ratio	CR	Viewing Normal Angle $\theta_x=0^\circ, \theta_y=0^\circ$	1200	1500	-	-	(2)	
Response Time	Gray to gray average		-	6.5	12	ms	(3)	
Center Luminance of White	L _C		400	500	-	cd/	(4)	
Average Luminance of White	L _{AVE}		400	450	-	cd/		
White Variation	δW		-	-	1.3	-	(7)	
Cross Talk	CT		-	-	4.0	%	(5)	
Color Chromaticity	Red		R _x	Typ -0.03	0.643	Typ +0.03	-	(6)
			R _y		0.333		-	
	Green		G _x		0.272		-	
			G _y		0.595		-	
	Blue	B _x	0.144		-			
		B _y	0.069		-			
	White	W _x	0.280		-			
W _y		0.285	-					
Color Gamut	CG	70	72		%	NTSC		
Viewing Angle	Horizontal	θ_{x+}	80	88	-	Deg	(1)	
		θ_{x-}	80	88	-			
	Vertical	θ_{y+}	80	88	-			
		θ_{y-}	80	88	-			

Note (1) Definition of Viewing Angle (θ_x, θ_y):

Viewing angles are measured by EZ-Contrast 160R (Eldim)

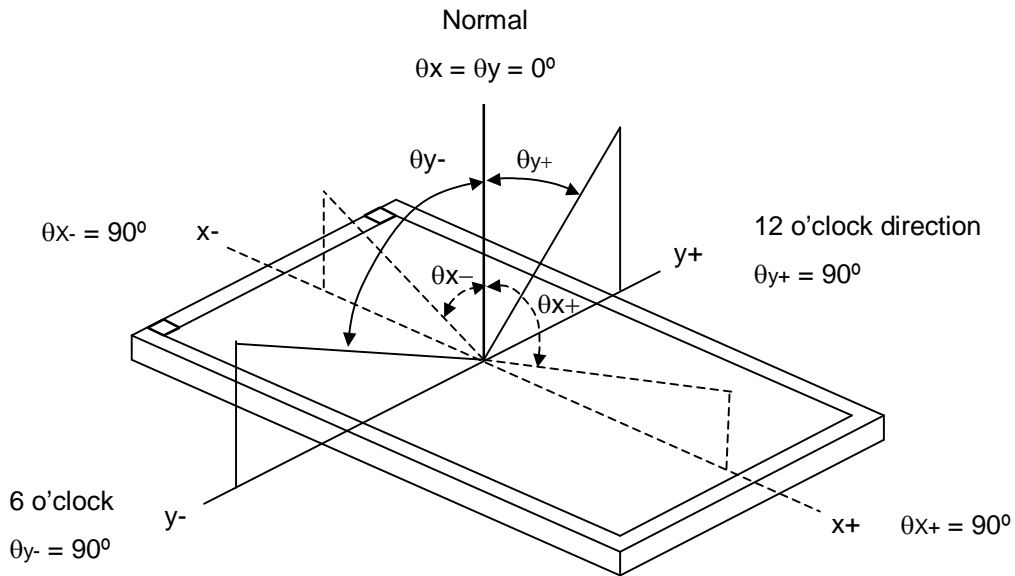

Note (2) Definition of Contrast Ratio (CR):

The contrast ratio can be calculated by the following expression.

$$\text{Contrast Ratio (CR)} = L_{255} / L_0$$

L255: Luminance of gray level 255

L 0: Luminance of gray level 0

CR = CR (5), where CR (X) is corresponding to the Contrast Ratio of the point X at the figure in Note (7).

Note (3) Definition of Gray to Gray Switching Time :

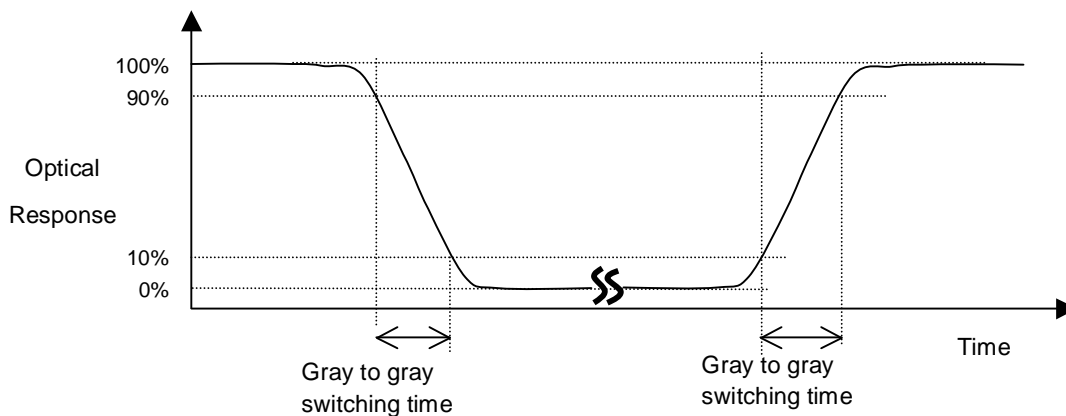

The driving signal means the signal of gray level 0, 63, 127, 191, 255.

Gray to gray average time means the average switching time of gray level 0, 63, 127, 191, 255 to each other .

Note (4) Definition of Luminance of White (L_C , L_{AVE}):

Measure the luminance of gray level 255 at center point and 5 points

$$L_C = L(5)$$

$$L_{AVE} = [L(1) + L(2) + L(3) + L(4) + L(5)] / 5$$

where $L(x)$ is corresponding to the luminance of the point X at the figure in Note (7).

Note (5) Definition of Cross Talk (CT):

$$CT = |Y_B - Y_A| / Y_A \times 100 (\%)$$

Where:

Y_A = Luminance of measured location without gray level 0 pattern (cd/m^2)

Y_B = Luminance of measured location with gray level 0 pattern (cd/m^2)

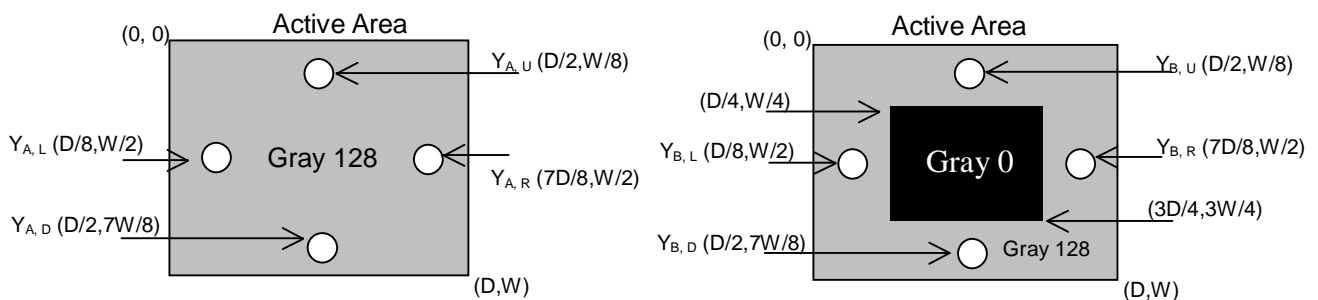

Note (6) Measurement Setup:

The LCD module should be stabilized at given temperature for 1 hour to avoid abrupt temperature change during measuring. In order to stabilize the luminance, the measurement should be executed after lighting Backlight for 1 hour in a windless room.

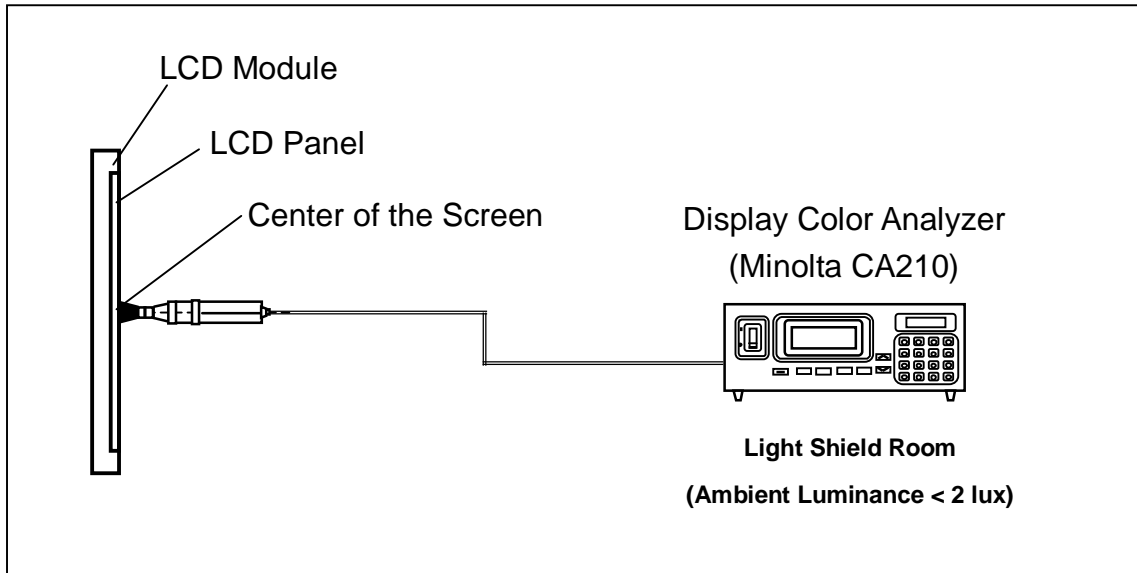

Note (7) Definition of White Variation (δW):

Measure the luminance of gray level 255 at 5 points

$$\delta W = \text{Maximum [L (1), L (2), L (3), L (4), L (5)]} / \text{Minimum [L (1), L (2), L (3), L (4), L (5)]}$$

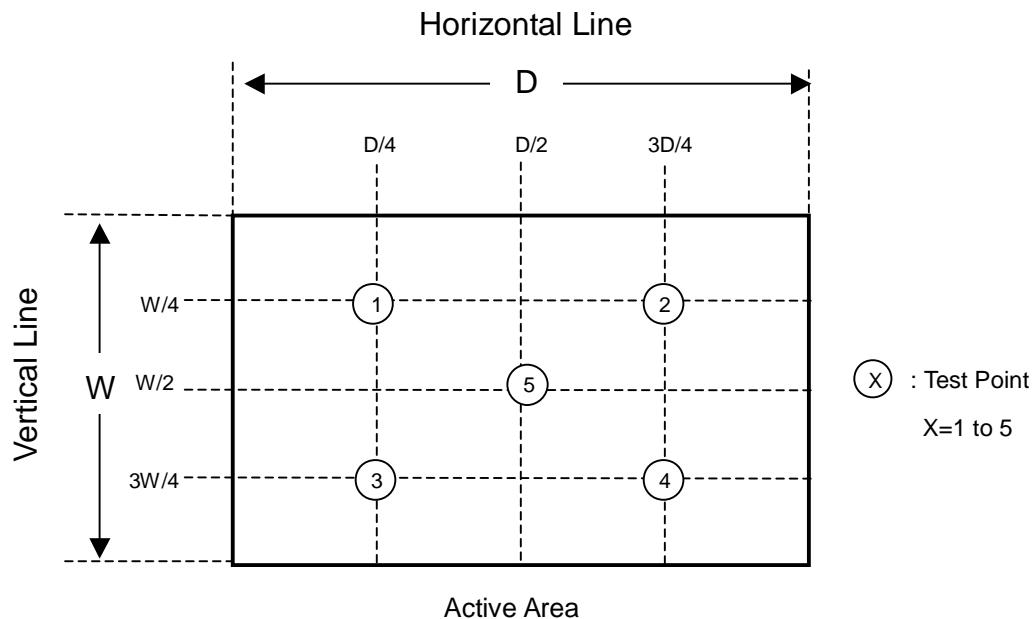

8. DEFINITION OF LABELS

8.1 CMO MODULE LABEL

The barcode nameplate is pasted on each module as illustration, and its definitions are as following explanation.

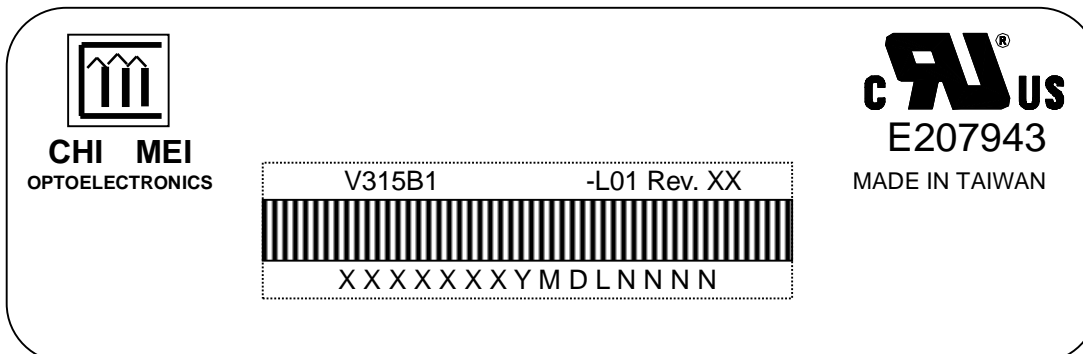

- (a) Model Name: V315B1-L01
- (b) Revision: Rev. XX, for example: A0, A1... B1, B2... or C1, C2...etc.
- (c) Serial ID: XXXXXXXXYMDLNNNN

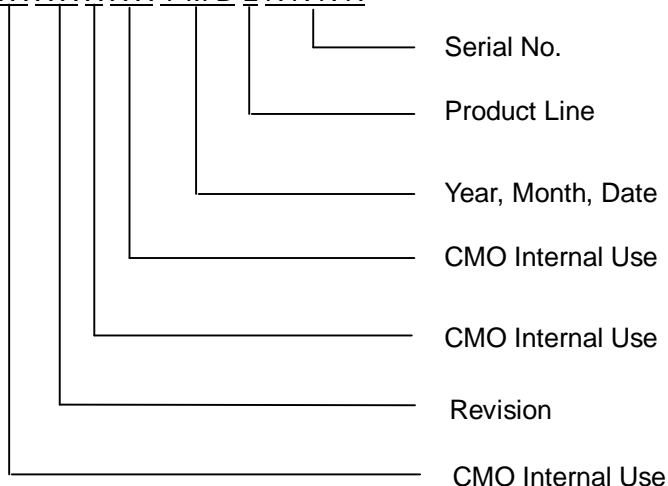

Serial ID includes the information as below:

- (a) Manufactured Date: Year: 0~9, for 2000~2009
 Month: 1~9, A~C, for Jan. ~ Dec.
 Day: 1~9, A~Y, for 1st to 31st, exclude I ,O, and U.
- (b) Revision Code: Cover all the change
- (c) Serial No.: Manufacturing sequence of product
- (d) Product Line: 1 -> Line1, 2 -> Line 2, ...etc.

9. PACKAGING

9.1 PACKING SPECIFICATIONS

- (1) 5 LCD TV modules / 1 Box
- (2) Box dimensions : 834(L) X 380 (W) X 530 (H)
- (3) Weight : approximately 38.5Kg (5 modules per box)

9.2 PACKING METHOD

Figures 9-1 and 9-2 are the packing method

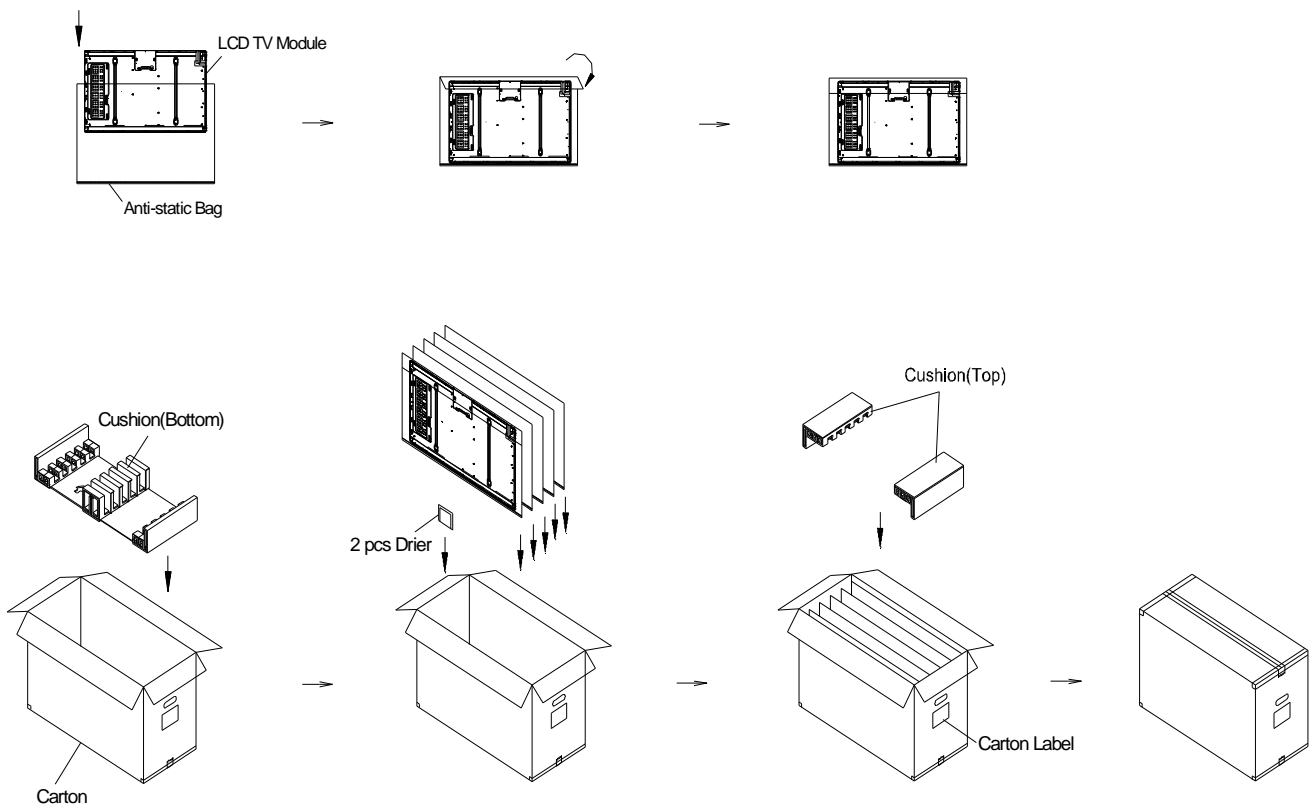
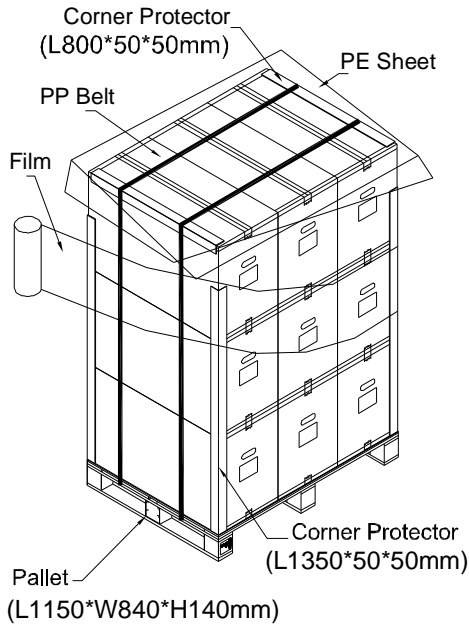
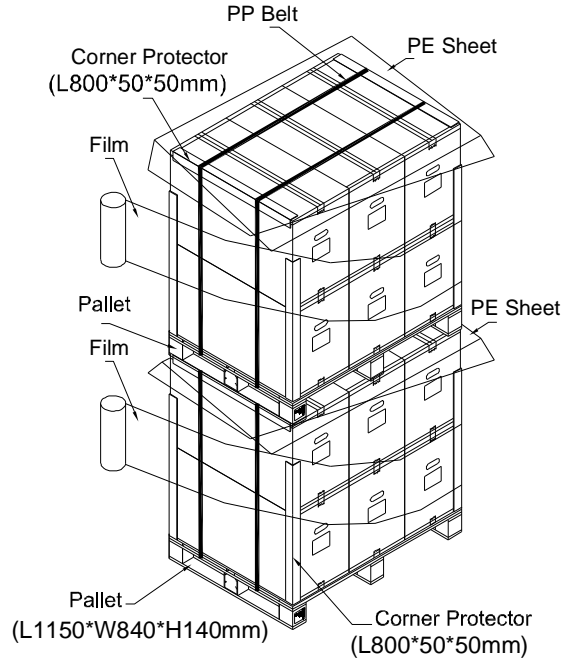

Figure.9-1 packing method

Sea / Land Transportation
(40ft Container)



Sea / Land Transportation
(40ft HQ Container)



Air Transportation

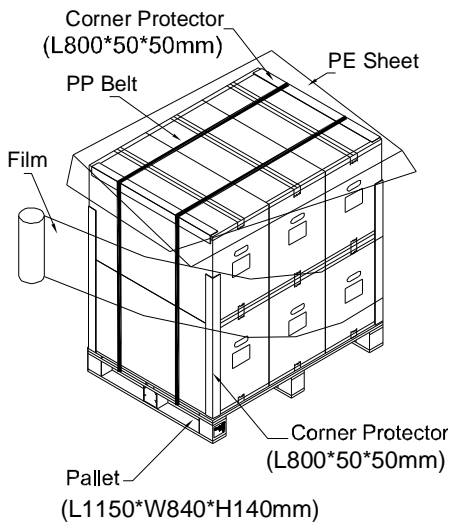

Figure.9-2 packing method

10. PRECAUTIONS

10.1 ASSEMBLY AND HANDLING PRECAUTIONS

- (1) Do not apply rough force such as bending or twisting to the module during assembly.
- (2) It is recommended to assemble or to install a module into the user's system in clean working areas. The dust and oil may cause electrical short or worsen the polarizer.
- (3) Do not apply pressure or impulse to the module to prevent the damage of LCD panel and backlight.
- (4) Always follow the correct power-on sequence when the LCD module is turned on. This can prevent the damage and latch-up of the CMOS LSI chips.
- (5) Do not plug in or pull out the I/F connector while the module is in operation.
- (6) Do not disassemble the module.
- (7) Use a soft dry cloth without chemicals for cleaning, because the surface of polarizer is very soft and easily scratched.
- (8) Moisture can easily penetrate into LCD module and may cause the damage during operation.
- (9) High temperature or humidity may deteriorate the performance of LCD module. Please store LCD modules in the specified storage conditions.
- (10) When ambient temperature is lower than 10°C, the display quality might be reduced. For example, the response time will become slow, and the starting voltage of CCFL will be higher than that of room temperature.

10.2 SAFETY PRECAUTIONS

- (1) The startup voltage of a backlight is over 1000 Volts. It may cause an electrical shock while assembling with the inverter. Do not disassemble the module or insert anything into the backlight unit.
- (2) If the liquid crystal material leaks from the panel, it should be kept away from the eyes or mouth. In case of contact with hands, skin or clothes, it has to be washed away thoroughly with soap.
- (3) After the module's end of life, it is not harmful in case of normal operation and storage.

11. REGULATORY STANDARDS

11.1 SAFETY

Regulatory	Item	Standard
Information Technology equipment	UL	UL 60950-1: 2003
	cUL	CAN/CSA C22.2 No.60950-1-03
	CB	IEC 60950-1:2001
Audio/Video Apparatus	UL	UL 60065: 2003
	cUL	CAN/CSA C22.2 No.60065-03
	CB	IEC 60065:2001

12. MECHANICAL CHARACTERISTICS

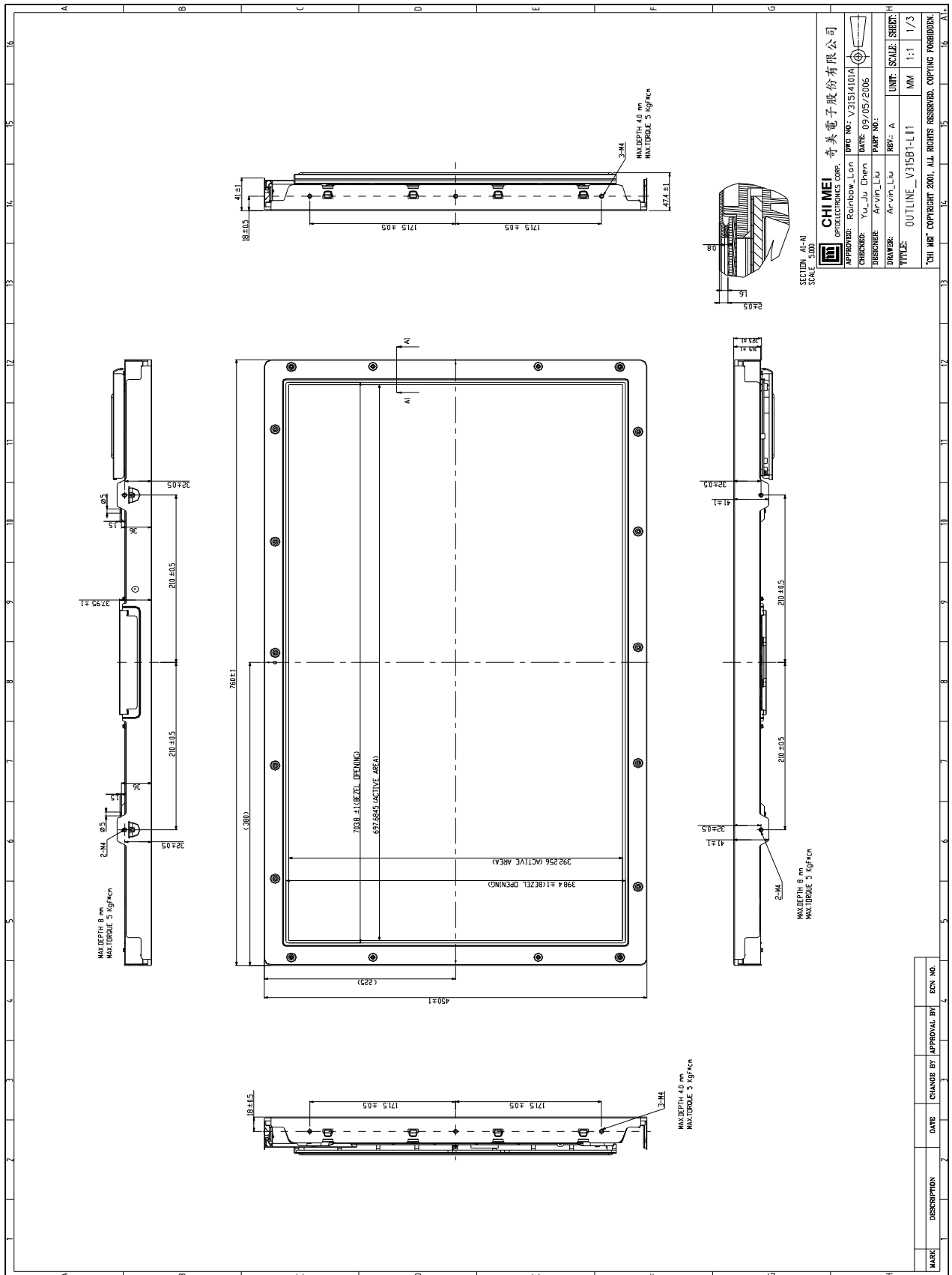

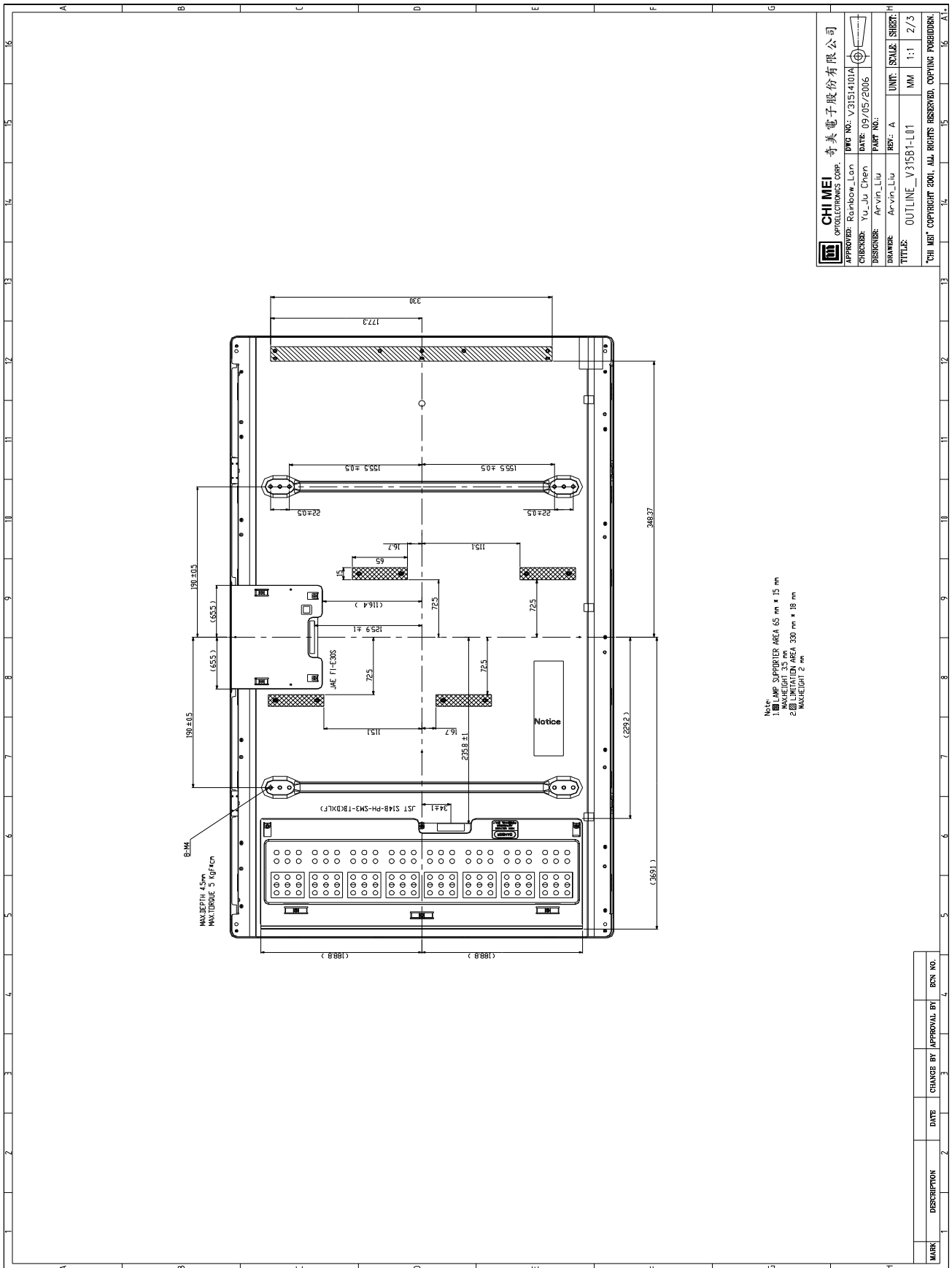

CHI MEI
OPTOELECTRONICS CORP. 奇美電子股份有限公司

APPROVER: Rainbow_Lan DWG No.: V315B1A101A
 CHECKER: Yu_Ju Chen DATE: 09/05/2006
 DESIGNER: Arvin_Liu PART NO.:
 DRAWER: Arvin_Liu REV.: A UNIT: SCALE: SHEET:
 TITLE: OUTLINE_V315B1-L01 MM 1:1 2/3
 "CHI MEI" COPYRIGHT 2001. ALL RIGHTS RESERVED. COPYING PROHIBITED.

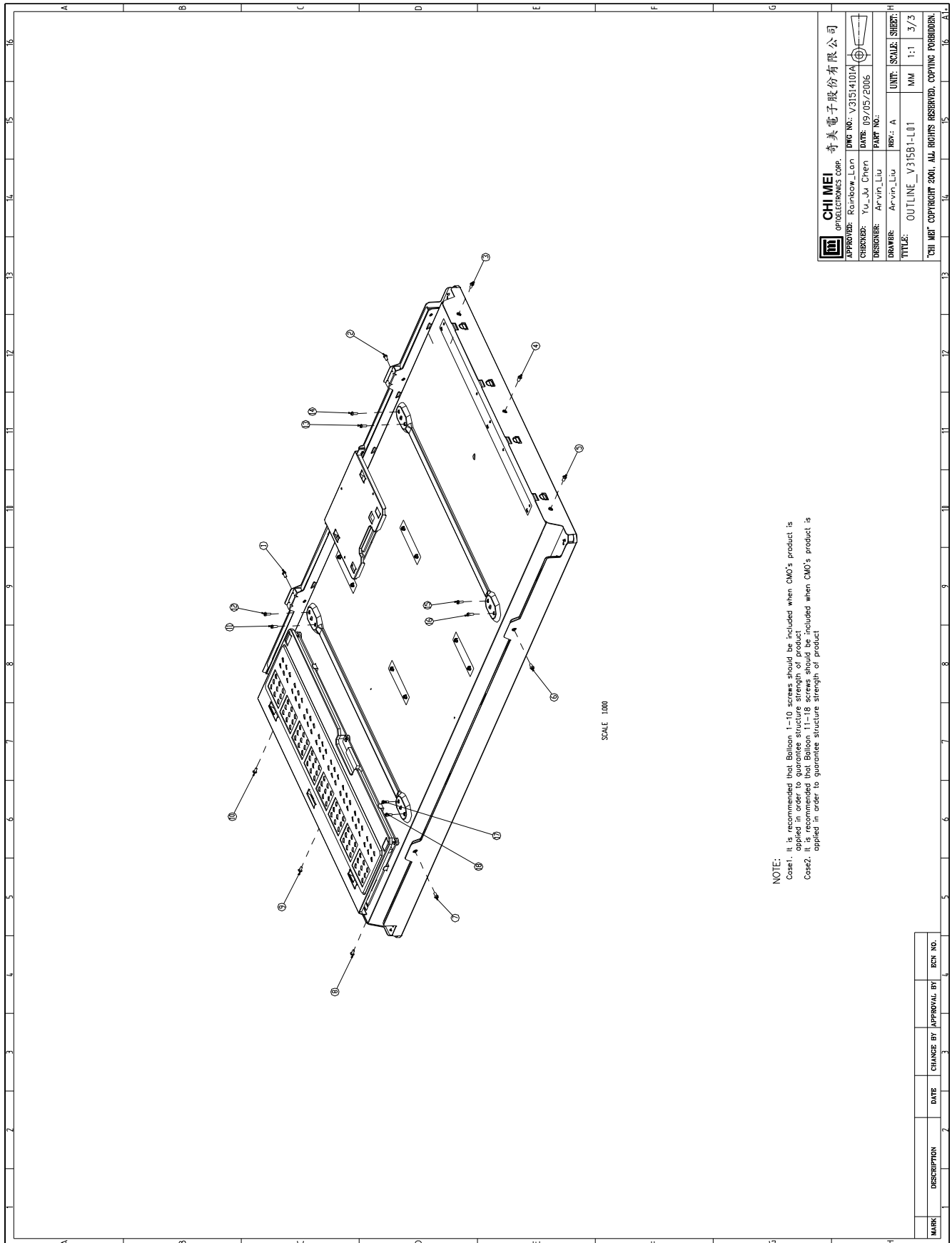

NOTE:
Case1. It is recommended that Balloon 1-10 screws should be included when CMO's product is applied in order to guarantee structure strength of product.
Case2. It is recommended that Balloon 11-18 screws should be included when CMO's product is applied in order to guarantee structure strength of product.

CHI MEI OPTOELECTRONICS CORP. 奇美電子股份有限公司	
APPROVED: Rainbow_Lan	DWG NO.: V31514101A
DESIGNED: Yu_Ju Chen	DATE: 09/05/2006
DRAWER: Arvin_Liu	PART NO.:
UNIT: Arvin_Liu	REV.: A
TITLE: OUTLINE_V315B1-L01	MM 1:1 3/3
"CHI MEI" COPYRIGHT 2001. ALL RIGHTS RESERVED. COPYING PROHIBITED.	

MARK	DESCRIPTION	DATE	CHANGE BY	APPROVAL BY	ECN NO.