

- Tentative Specification
 Preliminary Specification
 Approval Specification

MODEL NO.: V315BI
SUFFIX:L02

Customer :

APPROVED BY

SIGNATURE

Name / Title _____

Note

Please return 1 copy for your confirmation with your signature and comments.

Approved By	Checked By	Prepared By
Chao-Chun Chung	Josh Chi	Chloe Chen

- CONTENTS -

REVISION HISTORY	-----	3
1. GENERAL DESCRIPTION		
1.1 OVERVIEW		
1.2 CHARACTERISTICS	-----	4
2. ELECTRICAL SPECIFICATIONS	-----	5
2.1 Pin assignment		
2.2 Absolute maximum ratings		
2.3 Electrical characteristics		
3. OPTICAL SPECIFICATIONS	-----	16
4. RELIABILITY TEST ITEMS	-----	20
5. SAFETY	-----	21
6. DISPLAY QUALITY	-----	21
7. HANDLING PRECAUTION	-----	21
8. LABEL	-----	22

REVISION HISTORY

Version	Date	Page(New)	Section	Description
Ver. 2.0	Aug 2,2010	All	All	The specification was first issued.

1. GENERAL DESCRIPTION

1.1 OVERVIEW

V315BI-L02 is a 31.5" TFT Liquid Crystal Display module. This module supports 1366 x 768 WXGA format and can display true 16.7M colors (8-bit).

1.2 CHARACTERISTICS

NO.	Item	Specification	Remark
1	Display resolution (pixel)	1,366(H) X 768(V), WXGA+ resolution	
2	Active area (mm)	697.685 (H) X 392.256(V)	
3	Screen size (inch)	31.5 inches diagonal	
4	Pixel pitch (mm)	0.17025 (H) X 0.51075 (V)	
5	Color configuration	R, G, B vertical stripe	
6	Overall dimension (mm)	783.55 (W) X 462.55 (H) X 61.6(D)	
7	Weight (g)	5300	
8	Surface treatment	Anti-glare, Haze=11%, Hard coating (3H)	Note 1
9	Input color signal	8 bit LVDS	
10	Display colors	16.7M	
11	Color saturation	72% NTSC	
12	Backlight	4U CCFL	
13	RoHS & Halogen free	RoHS & Halogen free compliance	

Note 1: Glare Option available

2. Electrical specifications

2.1 Pin assignment

CN1 Connector Pin Assignment

Pin No.	Symbol	Description	Note
1	NC	No connection	(3)
2	SCL	EEPROM Serial Clock	
3	SDA	EEPROM Serial Data	
4	GND	Ground	
5	RX0-	Negative transmission data of pixel 0	
6	RX0+	Positive transmission data of pixel 0	
7	GND	Ground	
8	RX1-	Negative transmission data of pixel 1	
9	RX1+	Positive transmission data of pixel 1	
10	GND	Ground	
11	RX2-	Negative transmission data of pixel 2	
12	RX2+	Positive transmission data of pixel 2	
13	GND	Ground	
14	RXCLK-	Negative of clock	
15	RXCLK+	Positive of clock	
16	GND	Ground	
17	RX3-	Negative transmission data of pixel 3	
18	RX3+	Positive transmission data of pixel 3	
19	GND	Ground	
20	NC	No connection	(3)
21	SELLVDS	Select LVDS data format	(2),(4)
22	WP	EEPROM Write Protection	
23	GND	Ground	
24	GND	Ground	
25	GND	Ground	
26	VCC	Power supply: +12V	
27	VCC	Power supply: +12V	
28	VCC	Power supply: +12V	
29	VCC	Power supply: +12V	
30	VCC	Power supply: +12V	

Note (1) Connector Part No.: **UNE, FZC8-030-TF13 or compatible/ Yeonho 10031 HR-30**

LVDS connector pin order defined as follows

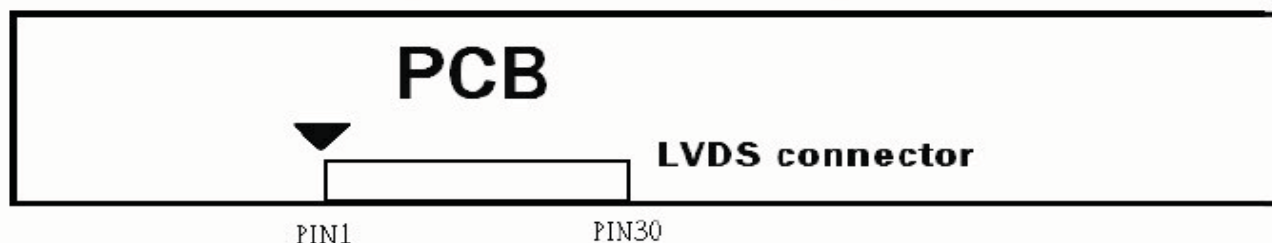

Note (2) High = Open or connect to +3.3V: VESA Format, Low = Connect to GND: JEIDA Format.

Please refer to 5.5 LVDS INTERFACE

Note (3) Reserved for internal use. Please leave it open.

Note (4) LVDS signal pin connected to the LCM side has the following diagram.

R1 in the system side should be less than 1K Ohm. (R1 < 1K Ohm)

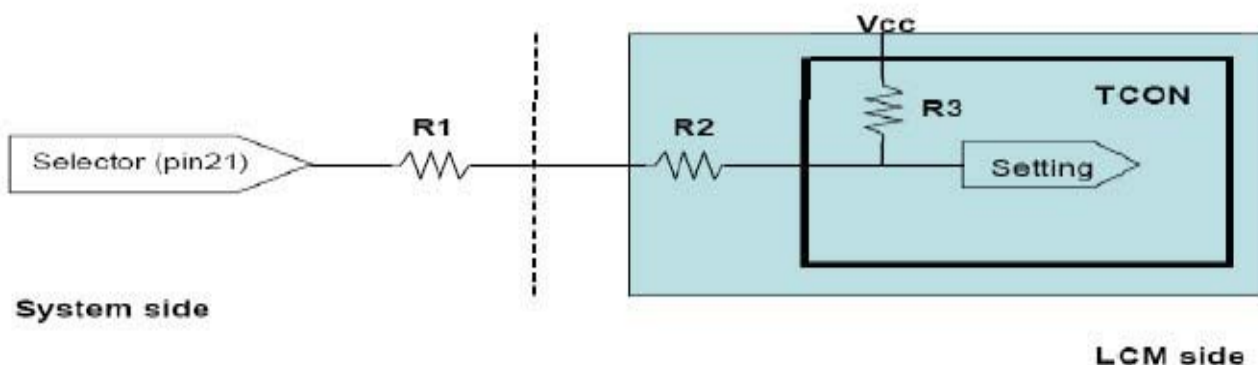

LVDS INTERFACE

VESA LVDS format : (SELLVDS pin=H or open)

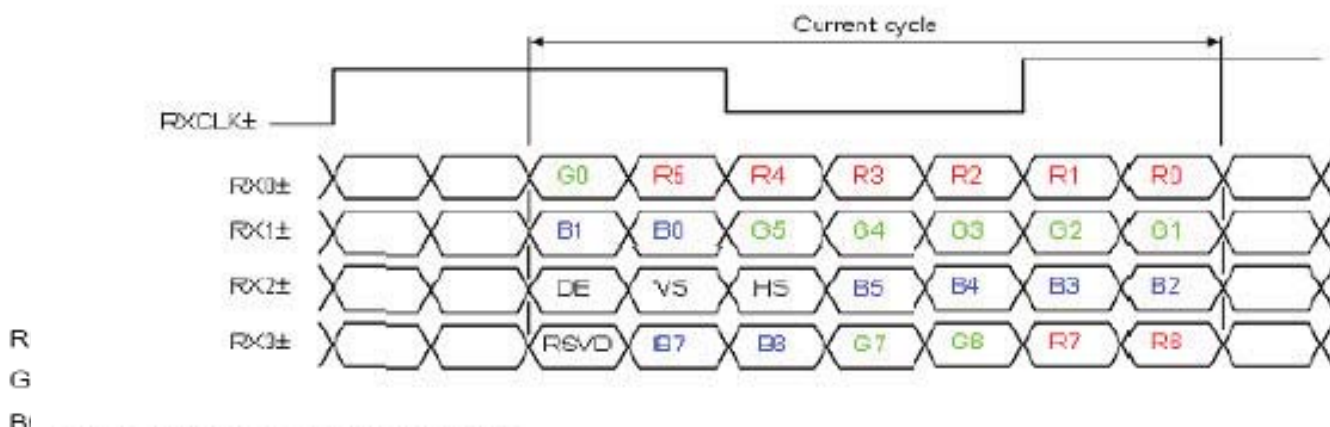

JEDIA LVDS format : (SELLVDS pin=L)

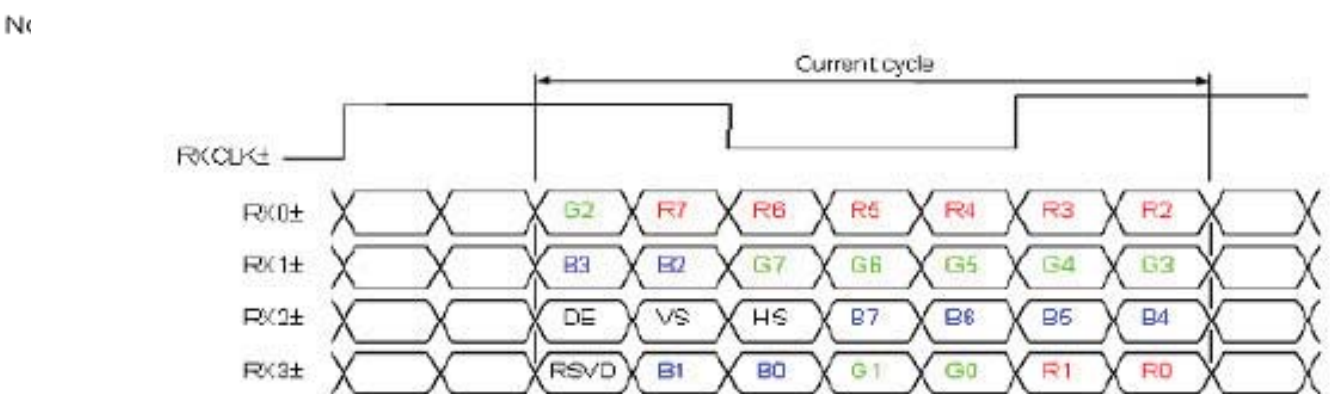

2.2. Absolute maximum ratings

Item	Symbol	Value		Unit	Note
		Min.	Max.		
Storage Temperature	T _{ST}	-20	+60	°C	(1),(3)
Operating Ambient Temperature	T _{OP}	0	+50	°C	(1),(2),(3)
Shock (Non-Operating)	S _{NOP}	-	50	G	(3),(5)
Vibration (Non-Operating)	V _{NOP}	-	1.0	G	(4),(5)

Note (1) Temperature and relative humidity range is shown in the figure below.

(a) 90 %RH Max. ($T_a \leq 40$ °C).

(b) Wet-bulb temperature should be 39 °C Max. ($T_a > 40$ °C).

(c) No condensation.

Note (2) The maximum operating temperature is based on the test condition that the surface temperature of display area is less than or equal to 65 °C with LCD module alone in a temperature controlled chamber.

Thermal management should be considered in final product design to prevent the surface temperature of display area from being over 65 °C. The range of operating temperature may degrade in case of improper thermal management in final product design

Note (3) 11 ms, half sine wave, 1 time for $\pm X$, $\pm Y$, $\pm Z$.

Note (4) 10 ~ 200 Hz, 10 min, 1 time each X, Y, Z.

Note (5) At testing Vibration and Shock, the fixture in holding the module has to be hard and rigid enough so that the module would not be twisted or bent by the fixture.

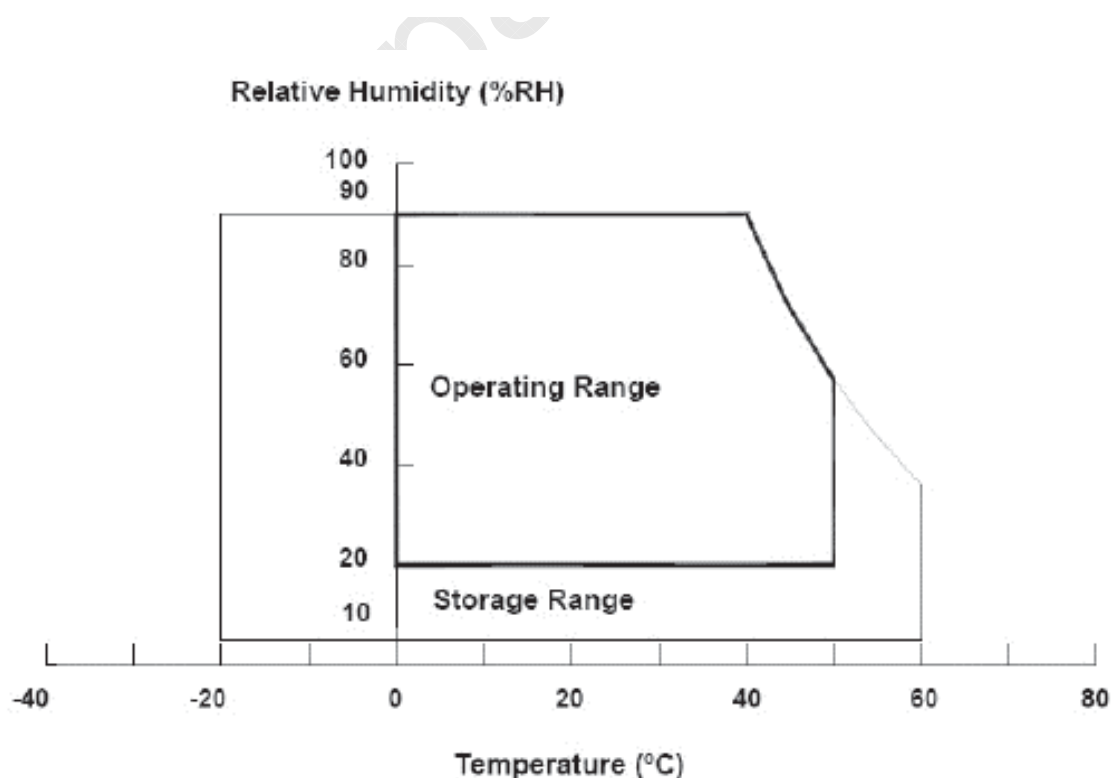

2.3 Electrical characteristics

2.3.1. TFT LCD MODULE

Parameter		Symbol	Value			Unit	Note
			Min.	Typ.	Max.		
Power Supply Voltage		V_{CC}	10.8	12.0	13.2	V	(1)
Rush Current		I_{RUSH}	—	—	3.0	A	(2)
Power Supply Current	White	I_{CC}	—	0.45	0.50	A	(3)
	Black		—	0.35	0.40	A	
	Vertical Stripe		—	0.45	0.50	A	
LVDS Interface	Differential Input High Threshold Voltage	V_{LVTH}	+100	—	—	mV	(4)
	Differential Input Low Threshold Voltage	V_{LVTL}	—	—	-100	mV	
	Common Input Voltage	V_{LVC}	1.0	1.2	1.4	V	
	Differential input voltage	$ V_{ID} $	200	—	600	mV	
	Terminating Resistor	R_T	—	100	—	ohm	
CMOS interface	Input High Threshold Voltage	V_{IH}	2.7	—	3.3	V	
	Input Low Threshold Voltage	V_{IL}	0	—	0.7	V	

Note (1) The module should be always operated within above ranges.

Note (2) Measurement Conditions:

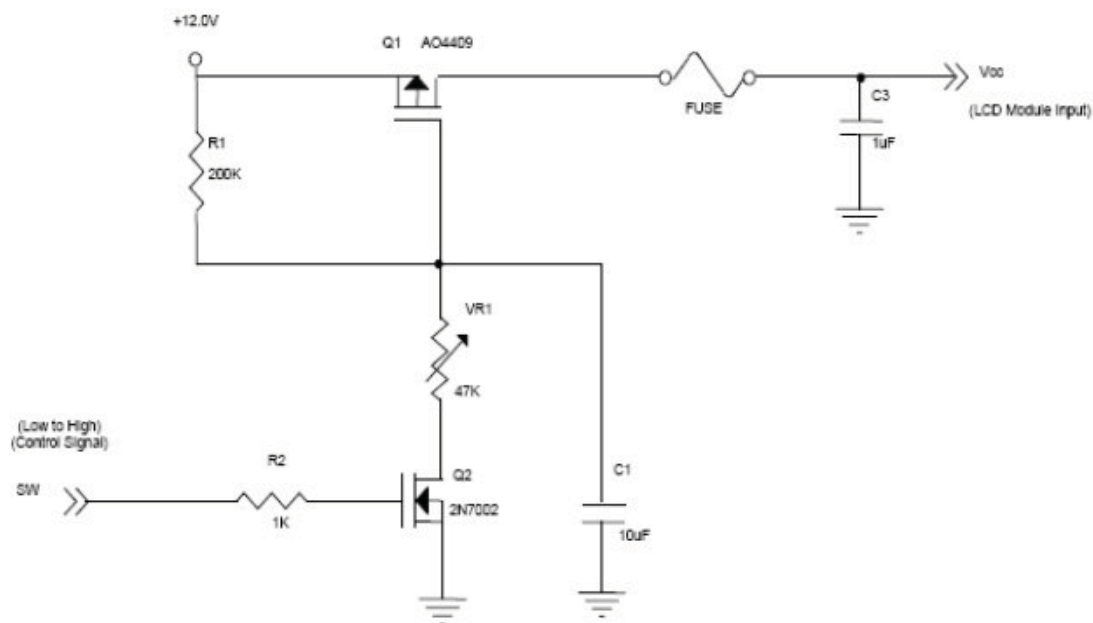

Vcc rising time is 470us

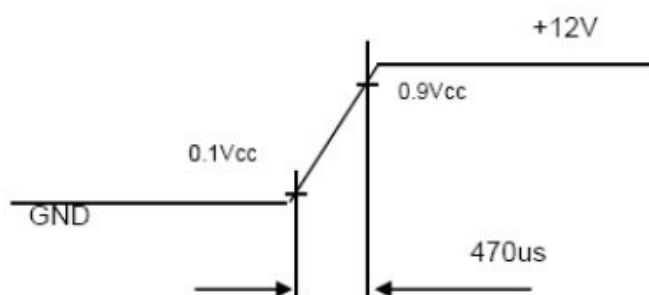

Note (3) The specified power supply current is under the conditions at $V_{CC} = 12\text{ V}$, $T_a = 25 \pm 2\text{ }^\circ\text{C}$, $f_v = 60\text{ Hz}$, whereas a power dissipation check pattern below is displayed.

a. White Pattern

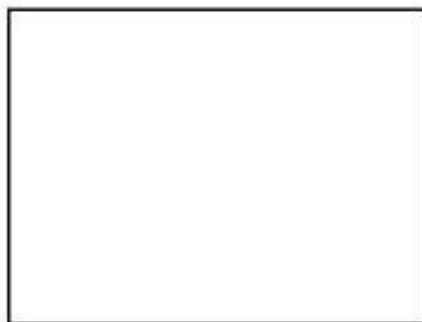

Active Area

b. Black Pattern



Active Area

c. Vertical Stripe Pattern

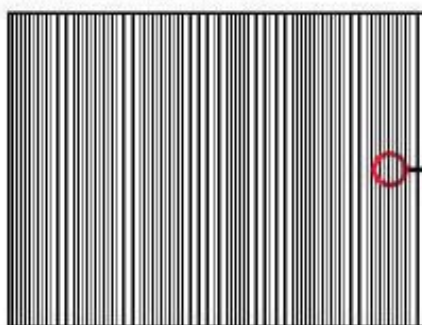

Active Area



Note (4) The LVDS input characteristics are as follows:

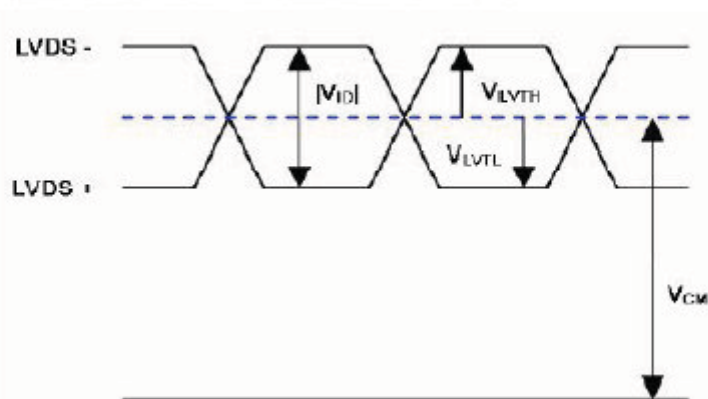

2.3.2. Display color vs. input data signals

The brightness of each primary color (red, green and blue) is based on the 8-bit gray scale data input for the color; the higher the binary input, the brighter the color. The table below provides a reference for color versus data input.

Color	Input color data																							
	Red								Green								Blue							
	MSB				LSB				MSB				LSB				MSB				LSB			
	R7	R6	R5	R4	R3	R2	R1	R0	G7	G6	G5	G4	G3	G2	G1	G0	B7	B6	B5	B4	B3	B2	B1	B0
Basic colors	Black	0	0	0	0	0	0	0	0	0	0	0	0	0	0	0	0	0	0	0	0	0	0	0
	Red(255)	1	1	1	1	1	1	1	0	0	0	0	0	0	0	0	0	0	0	0	0	0	0	0
	Green(255)	0	0	0	0	0	0	0	1	1	1	1	1	1	1	1	0	0	0	0	0	0	0	0
	Blue(255)	0	0	0	0	0	0	0	0	0	0	0	0	0	0	0	1	1	1	1	1	1	1	1
	Cyan	0	0	0	0	0	0	0	1	1	1	1	1	1	1	1	1	1	1	1	1	1	1	1
	Magenta	1	1	1	1	1	1	1	0	0	0	0	0	0	0	0	1	1	1	1	1	1	1	1
	Yellow	1	1	1	1	1	1	1	1	1	1	1	1	1	1	1	0	0	0	0	0	0	0	0
	White	1	1	1	1	1	1	1	1	1	1	1	1	1	1	1	1	1	1	1	1	1	1	1
Red	Red(000) dark	0	0	0	0	0	0	0	0	0	0	0	0	0	0	0	0	0	0	0	0	0	0	0
	Red(001)	0	0	0	0	0	0	1	0	0	0	0	0	0	0	0	0	0	0	0	0	0	0	0
	Red(002)	0	0	0	0	0	1	0	0	0	0	0	0	0	0	0	0	0	0	0	0	0	0	0
	:	:	:	:	:	:	:	:	:	:	:	:	:	:	:	:	:	:	:	:	:	:	:	:
	Red(253)	1	1	1	1	1	0	1	0	0	0	0	0	0	0	0	0	0	0	0	0	0	0	0
	Red(254)	1	1	1	1	1	1	0	0	0	0	0	0	0	0	0	0	0	0	0	0	0	0	0
	Red(255) bright	1	1	1	1	1	1	1	0	0	0	0	0	0	0	0	0	0	0	0	0	0	0	0
Green	Green(000)dark	0	0	0	0	0	0	0	0	0	0	0	0	0	0	0	0	0	0	0	0	0	0	0
	Green(001)	0	0	0	0	0	0	0	0	0	0	0	0	0	1	0	0	0	0	0	0	0	0	0
	Green(002)	0	0	0	0	0	0	0	0	0	0	0	0	1	0	0	0	0	0	0	0	0	0	
	:	:	:	:	:	:	:	:	:	:	:	:	:	:	:	:	:	:	:	:	:	:	:	:
	Green(253)	0	0	0	0	0	0	1	1	1	1	1	1	0	1	0	0	0	0	0	0	0	0	
	Green(254)	0	0	0	0	0	0	1	1	1	1	1	1	1	0	0	0	0	0	0	0	0	0	
	Green(255)bright	0	0	0	0	0	0	1	1	1	1	1	1	1	1	0	0	0	0	0	0	0	0	
Blue	Blue(000) dark	0	0	0	0	0	0	0	0	0	0	0	0	0	0	0	0	0	0	0	0	0	0	0
	Blue(001)	0	0	0	0	0	0	0	0	0	0	0	0	0	0	0	0	0	0	0	0	0	0	1
	Blue(002)	0	0	0	0	0	0	0	0	0	0	0	0	0	0	0	0	0	0	0	0	0	1	0
	:	:	:	:	:	:	:	:	:	:	:	:	:	:	:	:	:	:	:	:	:	:	:	:
	Blue(253)	0	0	0	0	0	0	0	0	0	0	0	0	0	0	0	1	1	1	1	1	1	0	1
	Blue(254)	0	0	0	0	0	0	0	0	0	0	0	0	0	0	0	1	1	1	1	1	1	1	0
	Blue(255) bright	0	0	0	0	0	0	0	0	0	0	0	0	0	0	0	1	1	1	1	1	1	1	1

2.3.3. Input signal timing

Support Input Timing Table

The input signal timing specifications are shown as the following table and timing diagram.

Signal	Item	Symbol	Min.	Typ.	Max.	Unit	Note
LVDS Receiver Clock	Frequency	F_{dkin} (=1/TC)	60	76	82	MHz	
	Input cycle to cycle jitter	T_{rcj}	—	—	200	ps	(3)
	Spread spectrum modulation range	F_{dkin_mod}	$F_{dkin}-2\%$	—	$F_{dkin}+2\%$	MHz	(4)
	Spread spectrum modulation frequency	F_{SSM}			200	KHz	
LVDS Receiver Data	Setup Time	$Tlvsu$	600	—	—	ps	(5)
	Hold Time	$Tlvhd$	600	—	—	ps	
Vertical Active Display Term	Frame Rate	F_{rs}	47	50	53	Hz	(6)
		F_{rd}	57	60	63	Hz	
	Total	T_v	778	806	888	Th	$T_v=T_{vd}+T_{vb}$
	Display	T_{vd}	768	768	768	Th	—
	Blank	T_{vb}	10	38	120	Th	—
Horizontal Active Display Term	Total	T_h	1442	1560	1936	Tc	$T_h=T_{hd}+T_{hb}$
	Display	T_{hd}	1366	1366	1366	Tc	—
	Blank	T_{hb}	76	194	570	Tc	—

Note (1) Please make sure the range of pixel clock has follow the below equation :

$$F_{dkin(max)} \geq F_{rs} \times T_v \times T_h$$

$$F_{rs} \times T_v \times T_h \geq F_{dkin(min)}$$

Note (2) This module is operated in DE only mode and please follow the input signal timing diagram below :

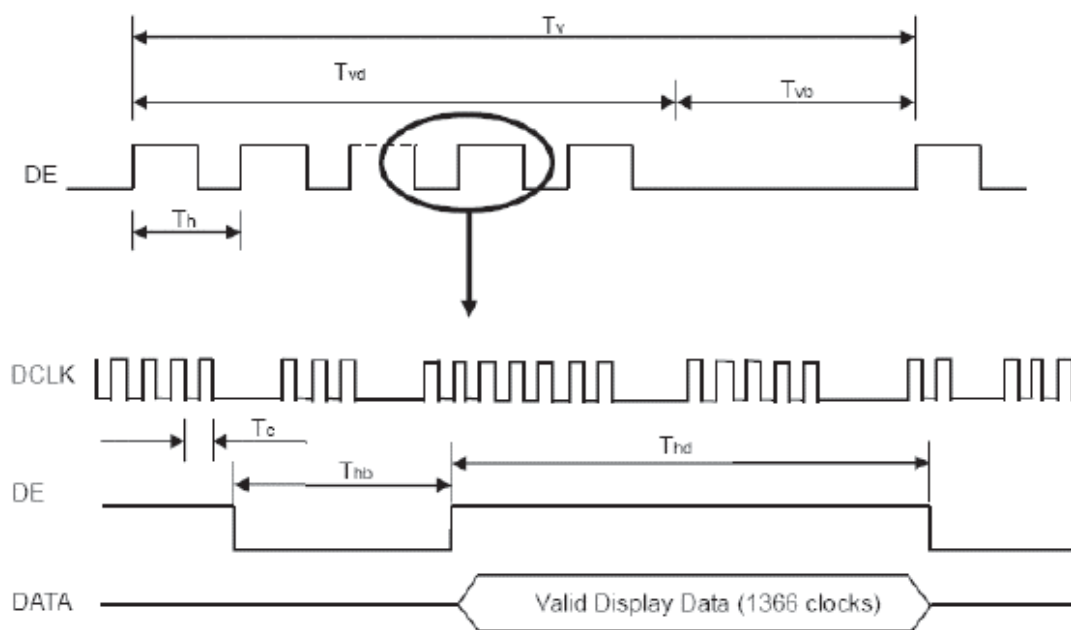
INPUT SIGNAL TIMING DIAGRAM

Note (3) The input clock cycle-to-cycle jitter is defined as below figures. $Trcl = |T_1 - T_1|$

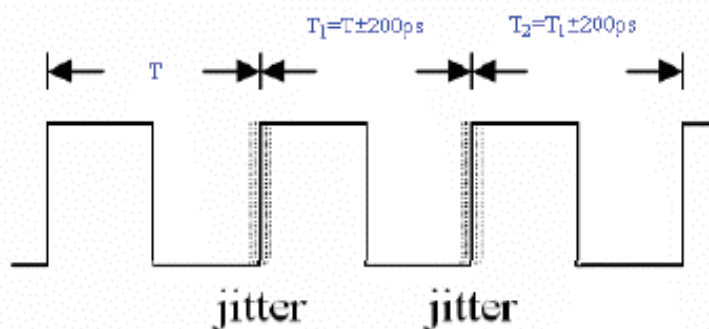

Note (4) The SSCG (Spread spectrum clock generator) is defined as below figures.

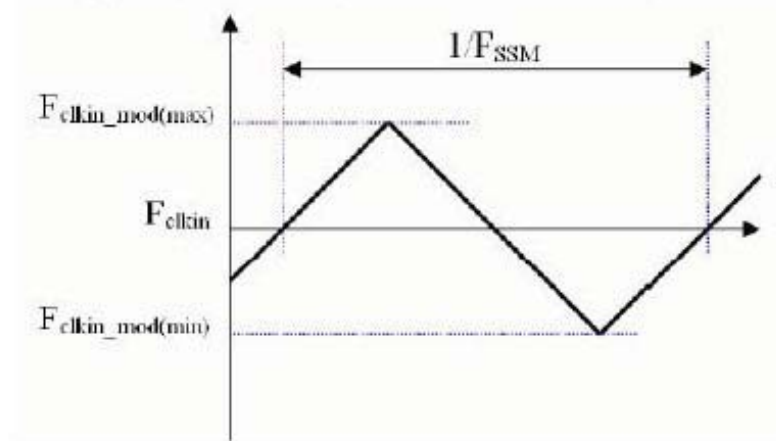

Note (5) The LVDS timing diagram and setup/hold time is defined and showing as the following figures.

LVDS RECEIVER INTERFACE TIMING DIAGRAM

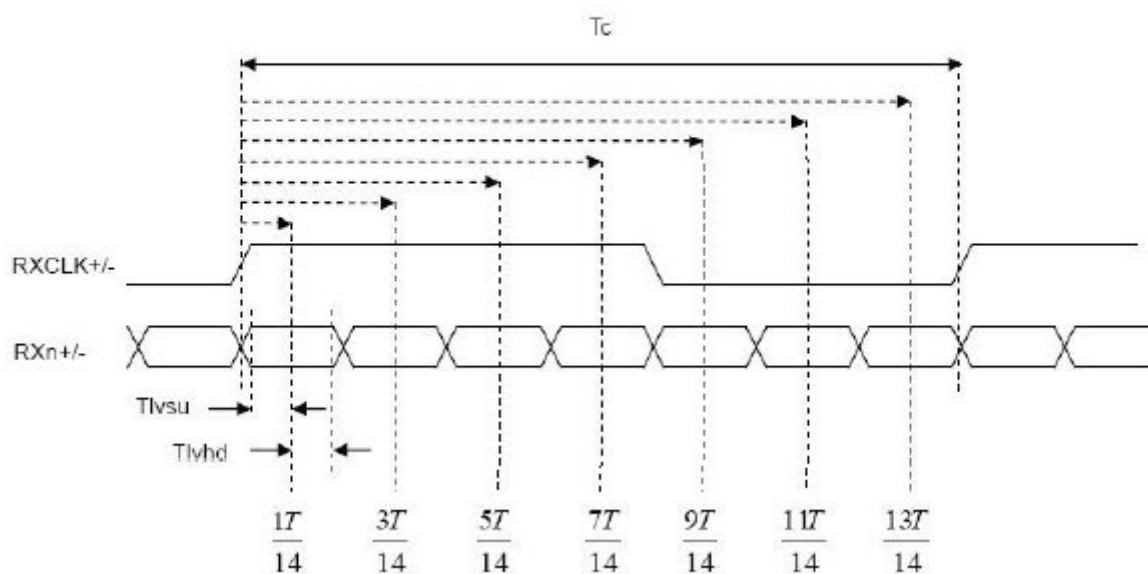

2.3.4. Display Position

D(1, 1)	D(2, 1)	D(683, 1)	D(1365, 1)	D(1366, 1)
D(1, 2)	D(2, 2)	D(683, 2)	D(1365, 2)	D(1366, 2)
⋮		⋮	⋮	⋮
D(1, 384)	D(2, 384)	D(683, 384)	D(1365, 384)	D(1366, 384)
⋮		⋮	⋮	⋮
D(1, 767)	D(2, 767)	D(683, 767)	D(1365, 767)	D(1366, 767)
D(1, 768)	D(2, 768)	D(683, 768)	D(1365, 768)	D(1366, 768)

2.3.5. Backlight driving conditions

Electrical specification

Parameter	Symbol	Value			Unit	Note
		Min.	Typ.	Max.		
Lamp Operate Voltage	V_L	--	1135	TBD	V_{RMS}	IL = 9.0mA (1)
Lamp Current	IL	--	9.0	9.5	mA_{RMS}	(1)
Lamp Starting Voltage	V_S	--	-	--- (0°C)	V_{RMS}	
		--	-	1590 (25°C)	V_{RMS}	
Operating Frequency	F_L	40		80		
Lamp Life Time	L_{SL}	50000	--	--		(2)
Power Consumption	P_L	--	10.215	---		IL = 9.0mA (1)

Note (1) Lamp current is measured by utilizing high frequency current meters as shown below:

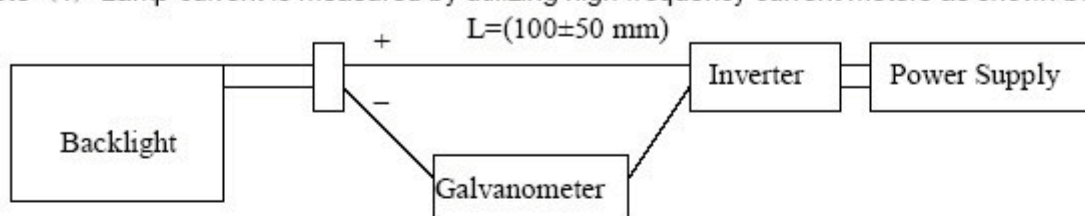

Note (2) CCFL Lifetime

Definition of the Lifetime:

The situation as below is a definition of service life while taking place:

- 1) Surface brightness descends to 50% of initial value.
- 2) The starting voltage is larger than the max value at 0°C in the Item 2.4.

Working Life

The guarantee lifetime of CCFL is 50000 hours in the operating mode.	
Environment temperature	25±3°C
FL tube current	9.0 mA rms
Lighting Status	Continued Lighting
FL Lighting Frequency	50KHz

Note 3: (1) Uniformity and flicker does not guarantee when the dimming control under 20%.

(2) 10% dimming function is okay, no shutdown occur.

3. Optical specifications

Item	Symbol	Condition	Specification			Unit	Remark
			Min.	Typ.	Max.		
G to G Response time	T _γ	θ = 0°	-	8.5	-	ms	Note 2
Contrast ratio	CR	θ = 0°	2300	3000	-		Note 1,3
Viewing angle	Top	CR ≥ 10	75	88	-	deg.	Note 1,3,5
	Bottom	CR ≥ 10	75	88	-		
	Left	CR ≥ 10	70	88	-		
	Right	CR ≥ 10	70	88	-		
Brightness (Center)	Y _L		300	350	-	nits	Note 1,4
Color chromaticity(CIE)	W _x	θ = 0°	-0.03	0.280	+0.03		Note 1
	W _y			0.290			
	R _x			0.643			
	R _y			0.331			
	G _x			0.276			
	G _y			0.597			
	B _x			0.144			
	B _y			0.069			
White uniformity (9)	δ _w		0.75	0.80	-		Note 1,6
Cross talk	C _t		-	-	2%		Note 7

Note : 1 Ambient temperature = 25°C.

2.To be measured in dark room after backlight warm up 30 minutes.

Note 1: To be measured with a viewing cone of 2° by Topcon luminance meter BM-5A.

Note 2: Note 2: G to G Response Time:

Response time T_γ is the average time required for display transition by switching the input signal for six luminance ratio (0%,20%,40%,60%,80%,100% brightness matrix) and is based on

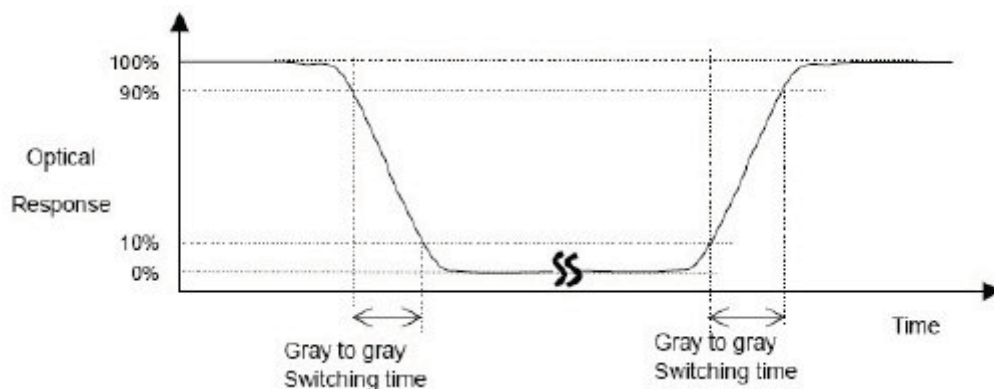

Note 3: Definition of contrast ratio:

Contrast ratio is calculated by the following formula.

$$\text{Contrast ratio (CR)} = \frac{\text{Brightness on the "white" state}}{\text{Brightness on the "black" state}}$$

Note 4: Driving conditions for CCFL: $I_L = 9.0 \text{ mA}$,

Note 5: Definition of viewing angle.

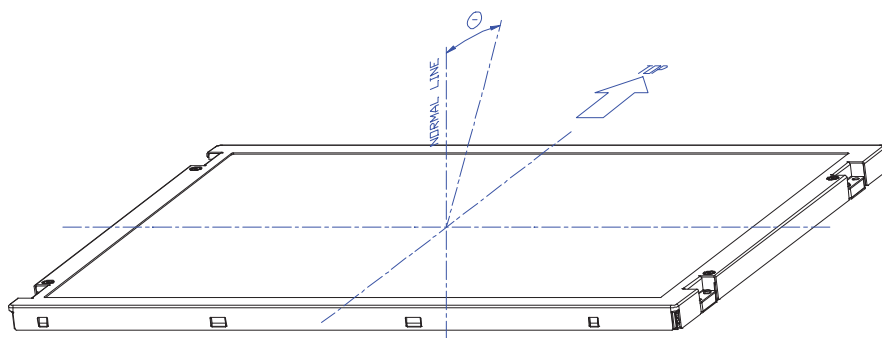

Note 6: Definition white uniformity:

Luminance are measured at the following nine points (P1~P9).

$$\delta_w = \frac{\text{Minimum Brightness of nine points (P1~P9)}}{\text{Maximum Brightness of nine points (P1~P9)}}$$

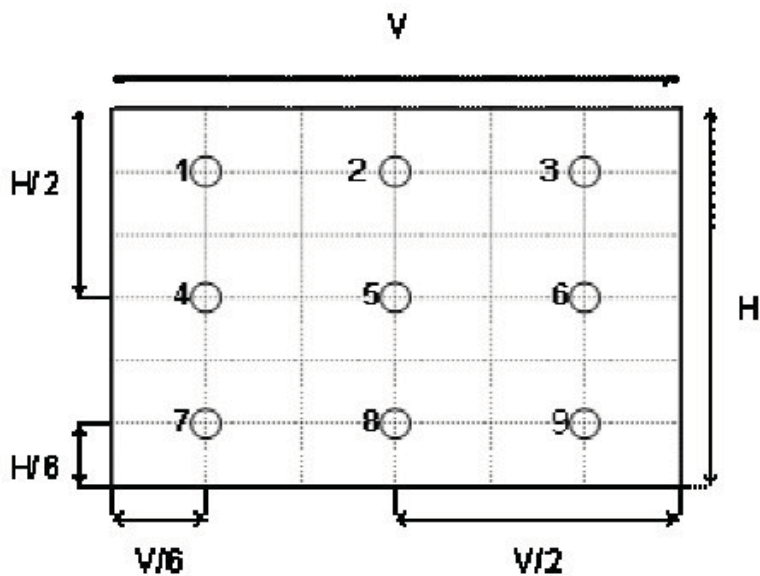

Note 7:

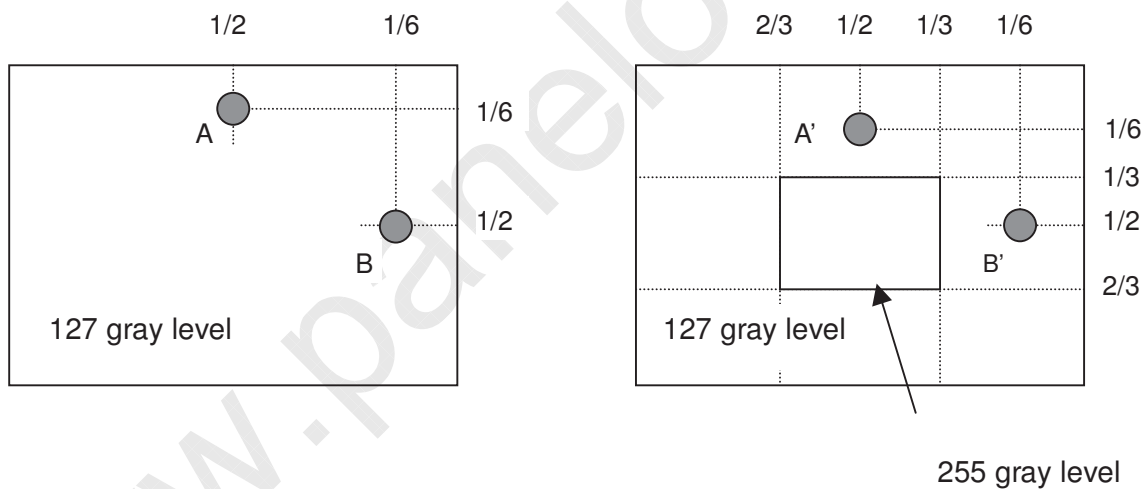

$|L_A - L_{A'}| / L_A \times 100\% = 2\% \text{ max.}$, L_A and $L_{A'}$ are brightness at location A and A'

$|L_B - L_{B'}| / L_B \times 100\% = 2\% \text{ max.}$, L_B and $L_{B'}$ are brightness at location B and B'

Note 10: Optical characteristic measurement setup.

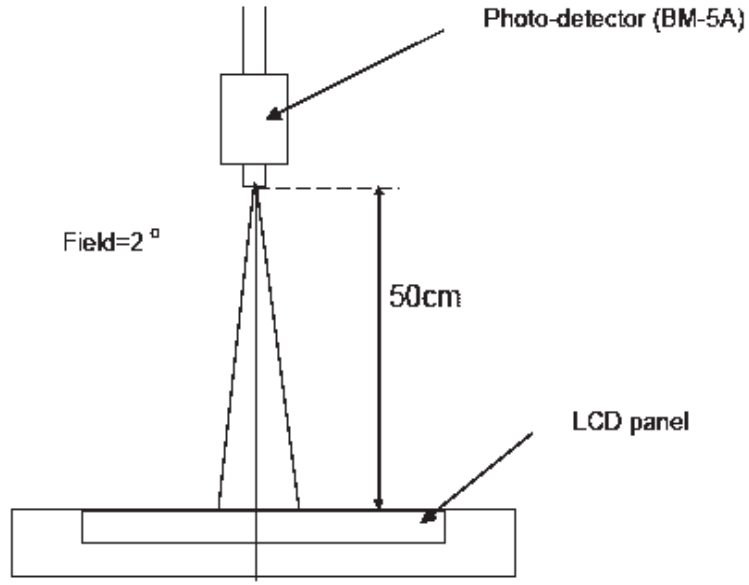

4. Reliability test items

Test Item	Test Condition	Judgment	Remark
High temperature storage	60°C, 240Hrs	Note 1	Note 2
Low temperature storage	-20°C, 240Hrs	Note 1	Note 2
High temperature operation	50°C, 240Hrs	Note 1	Note 2
Low temperature operation	0°C, 240Hrs	Note 1	Note 2
Vibration (non-operation)	Vibration level : 1.5G Bandwidth : 10-300Hz Waveform : sine wave, sweep rate : 10min 30 min for each direction X, Y, Z (1.5 Hrs in total)	Note 1	Note 2
Mechanical Shock (non-operation)	Shock level : 50G, 11ms Waveform : Half sine wave Direction : ±X, ±Y, ±Z One time each direction	Note 1	Note 2
Vibration test (with carton)	Random Wave (1.5 Grms 10~200Hz) 30mins / Per each X.Y.Z axes	Note 1	Note 2
Drop test (with carton)	Height : 38cm 1corner; 3edges; 6 surfaces	Note 1	Note 2
MTBF Demonstration	50,000 hours with confidence level 90%	Note 1	Note 3

Note1: Pass: Normal display image with no obvious non-uniformity and no line defect.

Partial transformation of the module parts should be ignored.

Fail: No display image, obvious non-uniformity, or line defects.

Note2: Evaluation should be tested after storage at room temperature for two hours.

Note 3: The MTBF calculation is based on the assumption that the failure rate distribution meets the Exponential Model (CCFL excluded)

5. Safety

(1) Sharp Edge Requirements

There will be no sharp edges or corners on the display assembly that could cause injury.

(2) Materials

5.1 Toxicity

There will be no carcinogenic materials used anywhere in the display module. If toxic materials are used, they will be reviewed and approved by the responsible InnoLux Toxicologist.

5.2 Flammability

All components including electrical components that do not meet the flammability grade UL94-V1 in the module will complete the flammability rating exception approval process. The printed circuit board will be made from material rated 94-V1 or better. The actual UL flammability rating will be printed on the printed circuit board.

5.3 Capacitors

If any polarized capacitors are used in the display assembly, provisions will be made to keep them from being inserted backwards.

6. Display quality

The display quality of the color TFT-LCD module should be in compliance with the Innolux's Incoming inspection standard.

7. Handling precaution

The Handling of the TFT-LCD should be in compliance with the Innolux's handling principle standard.

8. Label

8.1 CMO MODULE LABEL

The barcode nameplate is pasted on each module as illustration, and its definitions are as following explanation.

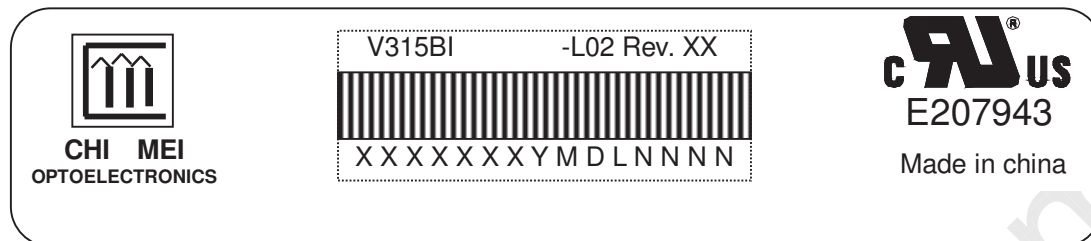

(a) Model Name: V315BI-L02

(b) Revision: Rev. XX, for example: A0, A1... B1, B2... or C1, C2...etc.

(c) Serial ID: X X X X X X Y M D L N N N N

