

TFT LCD Approval Specification

MODEL NO.: V315B1 - L04

Customer: _____ Approved by: _____ Note:
--

Approved By	TVHD	
	LY Chen	

Reviewed By	QRA Dept.	Product Development Div.
	Tomy Chen	WT Lin

Prepared By	LCD TV Marketing and Product Management Div.	
	WY LI	Jim Ho

- CONTENTS -

REVISION HISTORY	-----	3
1. GENERAL DESCRIPTION	-----	4
1.1 OVERVIEW		
1.2 FEATURES		
1.3 APPLICATION		
1.4 GENERAL SPECIFICATIONS		
1.5 MECHANICAL SPECIFICATIONS		
2. ABSOLUTE MAXIMUM RATINGS	-----	5
2.1 ABSOLUTE RATINGS OF ENVIRONMENT		
2.2 ELECTRICAL ABSOLUTE RATINGS		
2.2.1 TFT LCD MODULE		
2.2.2 BACKLIGHT UNIT		
2.3 ENVIROMENT TEST CONDITION		
3. ELECTRICAL CHARACTERISTICS	-----	8
3.1 TFT LCD MODULE		
3.2 BACKLIGHT INVERTER UNIT		
3.2.1 CCFL(Cold Cathode Fluorescent Lamp) CHARACTERISTICS		
3.2.2 INVERTER CHARACTERISTICS		
3.2.3 INVERTER INTERFACE CHARACTERISTICS		
4. BLOCK DIAGRAM	-----	13
4.1 TFT LCD MODULE		
5. INTERFACE PIN CONNECTION	-----	14
5.1 TFT LCD MODULE		
5.2 BACKLIGHT UNIT		
5.3 INVERTER UNIT		
5.4 BLOCK DIAGRAM OF INTERFACE		
5.5 LVDS INTERFACE		
5.6 COLOR DATA INPUT ASSIGNMENT		
6. INTERFACE TIMING	-----	21
6.1 INPUT SIGNAL TIMING SPECIFICATIONS		
6.2 POWER ON/OFF SEQUENCE		
7. OPTICAL CHARACTERISTICS	-----	24
7.1 TEST CONDITIONS		
7.2 OPTICAL SPECIFICATIONS		
8. DEFINITION OF LABELS	-----	27
8.1 CMO MODULE LABEL		
9. PACKAGING	-----	28
9.1 PACKING SPECIFICATIONS		
9.2 PACKING METHOD		
10. PRECAUTIONS	-----	30
10.1 ASSEMBLY AND HANDLING PRECAUTIONS		
10.2 SAFETY PRECAUTIONS		
11. REGULATORY STANDARDS	-----	30
11.1 SAFETY		
11.2 EMC		
12. MECHANICAL CHARACTERISTICS	-----	31

REVISION HISTORY

Version	Date	Page (New)	Section	Description
Ver 2.0 Ver2.1	Oct. 16'06 Dec.10'07	All 28,29	All 9	Approval Specification was first issued. PACKAGING

1. GENERAL DESCRIPTION

1.1 OVERVIEW

V315B1- L04 is a 31.5" TFT Liquid Crystal Display module with 16-CCFL Backlight unit and 1ch-LVDS interface. This module supports 1366 x 768 WXGA format and can display true 16.7M colors (8-bit colors). The inverter module for backlight is built-in.

1.2 FEATURES

- High brightness (500 nits)
- Ultra-high contrast ratio (1500:1)
- Faster response time (gray to gray average 6.5ms)
- High color saturation (CIE 1976 NTSC 85%)
- Ultra wide viewing angle : 176(H)/176(V) (CR>20) with Super MVA technology
- DE (Data Enable) only mode
- LVDS (Low Voltage Differential Signaling) interface
- 180 degree rotation display (option)
- Color reproduction (nature color)
- Low color shift function
- RoHS compliance

1.3 APPLICATION

- TFT LCD TVs
- Multi-Media Display

1.4 GENERAL SPECIFICATIONS

Item	Specification	Unit	Note
Active Area	697.6845 (H) x 392.256 (V) (31.51" diagonal)	mm	(1)
Bezel Opening Area	703.8 (H) x 398.4 (V)	mm	
Driver Element	a-si TFT active matrix	-	
Pixel Number	1366 x R.G.B. x 768	pixel	
Pixel Pitch (Sub Pixel)	1.53225 (H) x 0.51075 (V)	mm	
Pixel Arrangement	RGB vertical stripe	-	
Display Colors	16.7M	color	
Display Operation Mode	Transmissive mode / Normally black	-	
Surface Treatment	Anti-Glare coating (Haze 25%),Hard coating (3H)	-	

1.5 MECHANICAL SPECIFICATIONS

Item	Min.	Typ.	Max.	Unit	Note	
Module Size	Horizontal(H)	759.3	760	760.7	mm	(1)
	Vertical(V)	449.4	450	450.6	mm	(1)
	Depth(D)	34.1	34.6	35.1	mm	To rear surface
	Depth(D)	43.65	44.65	45.65	mm	To pcb cover
	Depth(D)	49.4	50.4	51.4	mm	To inverter cover
Weight	6550	6650	6750	g		

Note (1) Please refer to the attached drawings for more information of front and back outline dimensions.

2. ABSOLUTE MAXIMUM RATINGS

2.1 ABSOLUTE RATINGS OF ENVIRONMENT

Item	Symbol	Value		Unit	Note
		Min.	Max.		
Storage Temperature	T _{ST}	-20	+60	°C	(1)
Operating Ambient Temperature	T _{OP}	0	+50	°C	(1), (2)
Shock (Non-Operating)	S _{NOF}	-	50	G	(3), (5)
Vibration (Non-Operating)	V _{NOF}	-	1.0	G	(4), (5)

Note (1) Temperature and relative humidity range is shown in the figure below.

- (a) 90 %RH Max. ($T_a \leq 40$ °C).
- (b) Wet-bulb temperature should be 39 °C Max. ($T_a > 40$ °C).
- (c) No condensation.
- (d) 40°C / 95%RH Humidity is for reference.

Note (2) The maximum operating temperature is based on the test condition that the surface temperature of display area is less than or equal to 65 °C with LCD module alone in a temperature controlled chamber. Thermal management should be considered in final product design to prevent the surface temperature of display area from being over 65 °C. The range of operating temperature may degrade in case of improper thermal management in final product design.

Note (3) 11 ms, half sine wave, 1 time for $\pm X$, $\pm Y$, $\pm Z$.

Note (4) 10 ~ 500 Hz, 60 min, 1 time each X, Y, Z..

Note (5) At testing Vibration and Shock, the fixture in holding the module has to be hard and rigid enough so that the module would not be twisted or bent by the fixture.

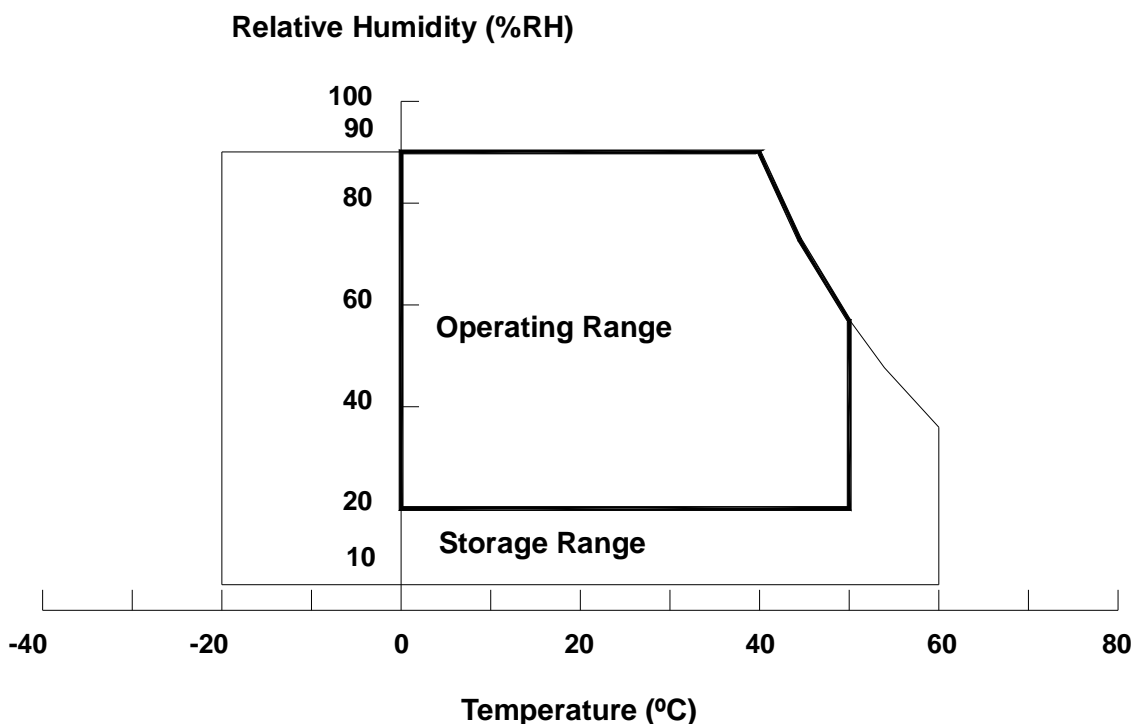

2.2 ELECTRICAL ABSOLUTE RATINGS

2.2.1 TFT LCD MODULE

Item	Symbol	Value		Unit	Note
		Min.	Max.		
Power Supply Voltage	V _{CC}	-0.3	6.0	V	(1)
Input Signal Voltage	V _{IN}	-0.3	3.6	V	

2.2.2 BACKLIGHT UNIT

Item	Symbol	Value		Unit	Note
		Min.	Max.		
Lamp Voltage	V _W	—	3000	V _{RMS}	
Power Supply Voltage	V _{BL}	0	30	V	(1)
Control Signal Level	—	-0.3	7	V	(1), (3)

Note (1) Permanent damage to the device may occur if maximum values are exceeded. Functional operation should be restricted to the conditions described under normal operating conditions.

Note (2) No moisture condensation or freezing.

Note (3) The control signals includes Backlight On/Off Control, I_PWM Control, E_PWM Control and ERR signal for inverter status output.

2.3 ENVIROMENT TEST CONDITION

No.	Test Item	Condition
1	High temperature storage test	Ta=60°C 500hrs
2	Low temperature storage test	Ta= -25°C 500hrs
3	High temperature high humidity storage test	Ta= 50oC 90%RH 500hrs (40oC 95%RH 500hrs judge for reference)
4	High temperature operation test	Ta= 50°C 500hrs
5	Low temperature operation test	Ta=0°C 500hrs
6	High temperature high humidity Operation	Ta= 40oC 95%RH 500hrs
7	Thermal shock	Ta= -25°C/ 60min~60°C/ 60min 100cycles
8	Vibration test (non-operation)	Wave form: Sine wave Vibration level: 1.0G Fre. range : 10~500Hz Duration: X, Y, Z, 60min, One time each direction
9	Shock test (non-operation)	Wave form: half sine wave, 11ms Shock level: 50G ±X, ±Y, ± Z, One time each direction
10	ESD	Storage: Contact mode +/-20kV, Air mode +/-20kV Operation: Contact mode +/-20kV, Air mode +/-20kV Condition: 150pF, 330ohm
11	Package Vibration	Wave form: Sine wave Vibration level: 1.0G Fre. range : 5~50Hz Duration: 15min for X, Y, 60 min for Z. One time each direction
12	Package Drop	Drop 1 corner, 3 sides, 6 faces, each one for 1 time. Height is 30cm. (Test environment: 25°C)

3. ELECTRICAL CHARACTERISTICS

3.1 TFT LCD MODULE

Ta = 25 ± 2 °C

Parameter		Symbol	Value			Unit	Note
			Min.	Typ.	Max.		
Power Supply Voltage		V _{CC}	4.5	5.0	5.5	V	(1)
Power Supply Ripple Voltage		V _{RP}	-	-	100	mV	
Rush Current		I _{RUSH}	-	-	4	A	(2)
Power Supply Current	White	I _{CC}	1.55	1.60	2.2	A	(3)
	Black		0.80	0.90	-	A	
	Vertical Stripe		1.35	1.40	-	A	
LVDS Interface	Differential Input High Threshold Voltage	V _{LVTH}	-	-	+100	mV	
	Differential Input Low Threshold Voltage	V _{LVTL}	-100	-	-	mV	
	Common Input Voltage	V _{LVC}	1.125	1.25	1.375	V	
	Terminating Resistor	R _T	-	100	-	ohm	
CMOS interface	Input High Threshold Voltage	V _{IH}	2.7	-	3.3	V	
	Input Low Threshold Voltage	V _{IL}	0	-	0.7	V	

Note (1) The module should be always operated within above ranges.

Note (2) Measurement Conditions:

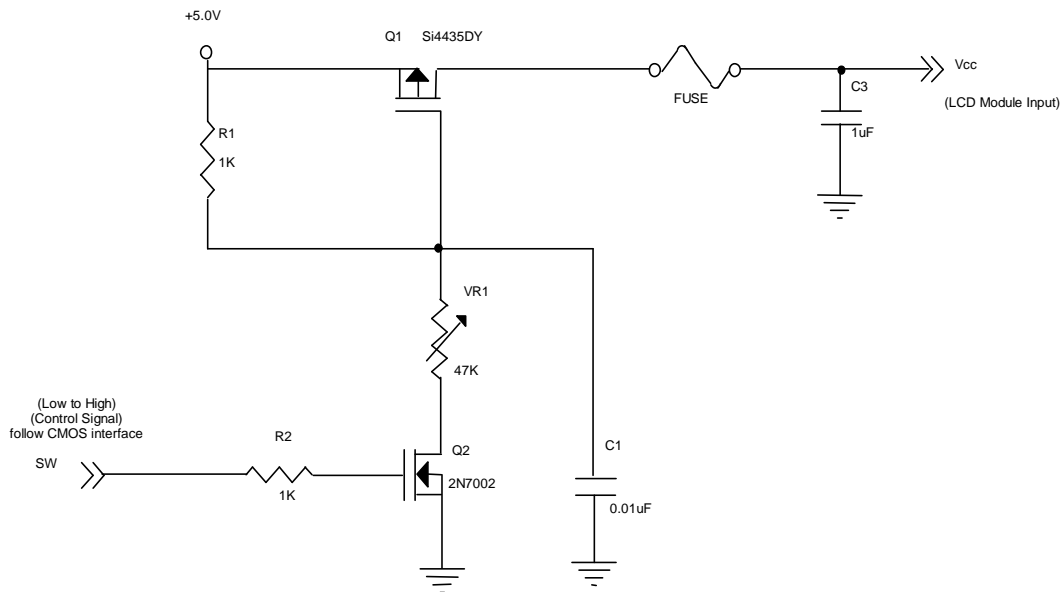

Vcc rising time is 470us

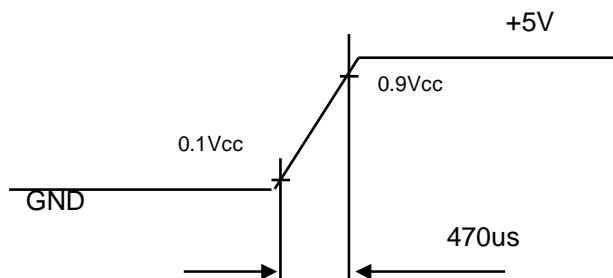

Note (3) The specified power supply current is under the conditions at $V_{CC} = 5\text{ V}$, $T_a = 25 \pm 2\text{ }^\circ\text{C}$, $f_v = 60\text{ Hz}$, whereas a power dissipation check pattern below is displayed.

a. White Pattern



Active Area

b. Black Pattern



Active Area

c. Vertical Stripe Pattern

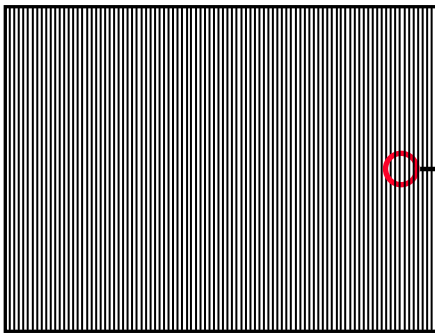

Active Area

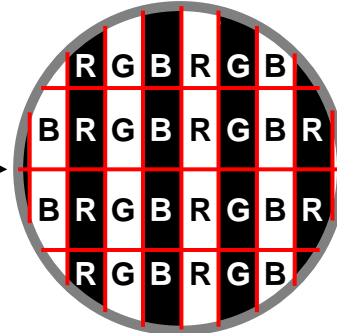

3.2 BACKLIGHT INVERTER UNIT

3.2.1 CCFL (Cold Cathode Fluorescent Lamp) CHARACTERISTICS ($T_a = 25 \pm 2\text{ }^\circ\text{C}$)

Parameter	Symbol	Value			Unit	Note
		Min.	Typ.	Max.		
Lamp Voltage	V_W	-	1250	-	V_{RMS}	$I_L = 5.0\text{mA}$
Lamp Current	I_L	4.5	5.0	5.5	mA_{RMS}	(1)
Lamp Starting Voltage	V_S	-	-	2450	V_{RMS}	(2), $T_a = 0\text{ }^\circ\text{C}$
		-	-	2360	V_{RMS}	(2), $T_a = 25\text{ }^\circ\text{C}$
Operating Frequency	F_O	40	-	70	KHZ	(3)
Lamp Life Time	L_{BL}	50,000	60,000	-	Hrs	(4)

3.2.2 INVERTER CHARACTERISTICS ($T_a = 25 \pm 2 \text{ }^\circ\text{C}$)

Parameter	Symbol	Value			Unit	Note
		Min.	Typ.	Max.		
Power Consumption	P_{BL}	-	104	115	W	(5)(6), $I_L = 5.0\text{mA}$ ADIM=1.6V or Open
Input Voltage	V_{BL}	22.8	24	26.4	V_{DC}	
Input Current	I_{BL}	-	4.3	-	A	Non Dimming
Input Ripple Noise	-	-	-	800	mV_{P-P}	$V_{BL}=22.8\text{V}$
Backlight Turn on Voltage	V_{BS}	2450	-	-	V_{RMS}	$T_a = 0 \text{ }^\circ\text{C}$
		2360	-	-	V_{RMS}	$T_a = 25 \text{ }^\circ\text{C}$
Oscillating Frequency	F_W	39	41	43	kHz	
Dimming frequency	F_B	161	164	167	Hz	
Minimum Duty Ratio	D_{MIN}	-	20	-	%	

Note (1) Lamp current is measured by utilizing high frequency current meters as shown below:

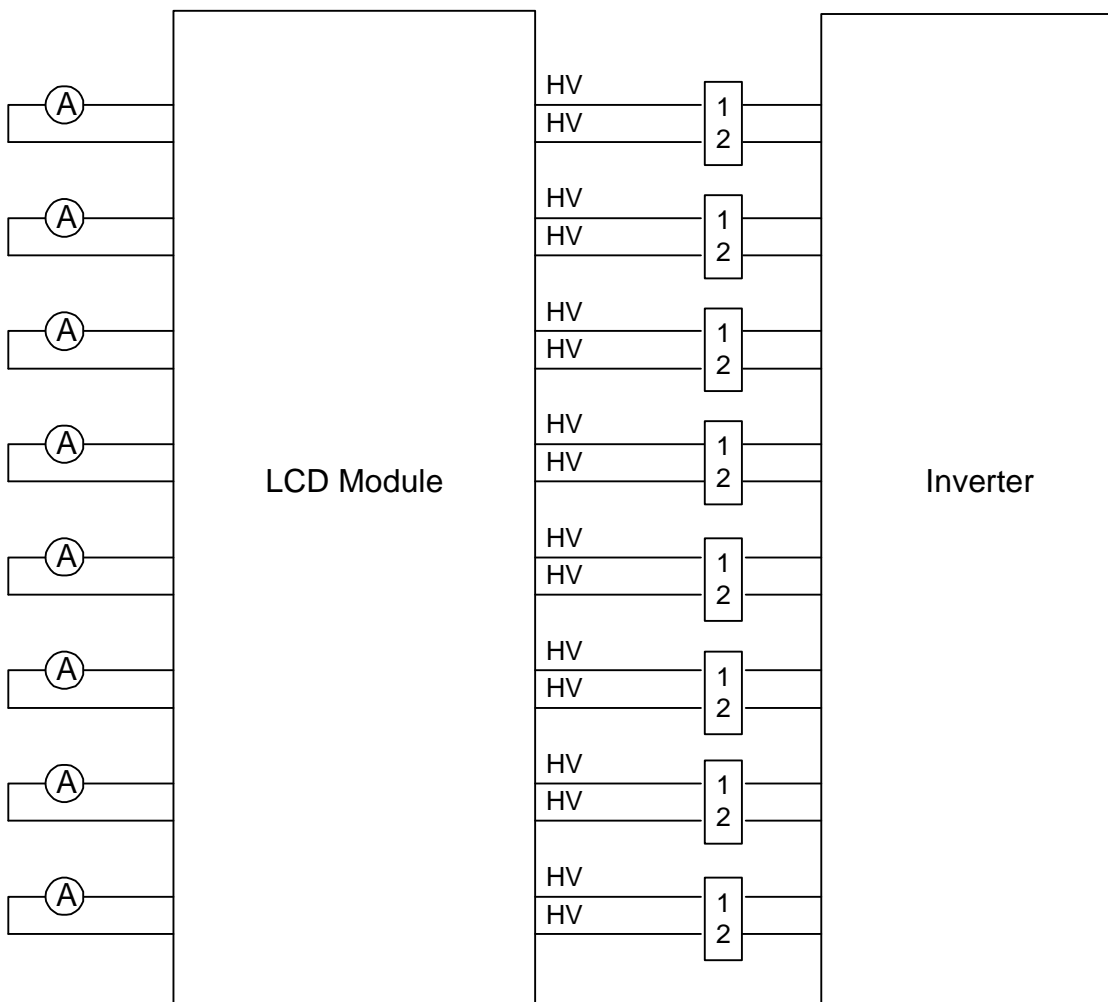

Note (2) The lamp starting voltage V_S should be applied to the lamp for more than 1 second under starting up duration. Otherwise the lamp could not be lighted on completed.

Note (3) The lamp frequency may produce interference with horizontal synchronous frequency of the display input signals, and it may result in line flow on the display. In order to avoid interference, the

lamp frequency should be detached from the horizontal synchronous frequency and its harmonics as far as possible.

Note (4) The life time of a lamp is defined as when the brightness is larger than 50% of its original value and the effective discharge length is longer than 80% of its original length (Effective discharge length is defined as an area that has equal to or more than 70% brightness compared to the brightness at the center point of lamp.) as the time in which it continues to operate under the condition at $T_a = 25 \pm 2^\circ\text{C}$ and $I_L = 4.5 \sim 5.5 \text{ mA}_{\text{RMS}}$.

Note (5) The power supply capacity should be higher than the total inverter power consumption P_{BL} . Since the pulse width modulation (PWM) mode was applied for backlight dimming, the driving current changed as PWM duty on and off. The transient response of power supply should be considered for the changing loading when inverter dimming.

Note (6) The measurement condition of Typ. value is based on 31.5" backlight unit under input voltage 24V, average lamp current 5.0 mA and lighting 30 minutes later.

3.2.3 INVERTER INTERFACE CHARACTERISTICS

No	ITEM	SYMBOL	TEST CONDITION	MIN	TYPE	MAX	UNIT	NOTE ⁽¹⁻²⁾	
1	On/Off Control Voltage	ON	ON/OFF	—	2.0	—	5.0	V	
		OFF		—	0	—	1.0	V	
2	PWM Selection	HI	SEL	—	2.0	—	5	V	
		LO		—	0	—	1.0	V	
2	Internal PWM Control Voltage	MAX	PDIM	SEL=H	3.3	—	5	V	Maximum Duty Ratio
		MIN			—	0	—	V	Minimum Duty Ratio
4	External PWM Control Voltage	HI	PDIM	SEL=L	2.0	—	5.0	V	ON Duration
		LO			0	—	1.0	V	OFF Duration
5	ADIM Control Voltage	ADIM	—	3.3	—	5.0	V	Lum=120%	
				—	—	1.65	—	V	Lum=100%
				—	—	0	—		Lum=80%
6	Control Signal Rising Time	T_r	—	—	—	100	ms		
7	Control Signal Falling Time	T_f	—	—	—	100	ms		
8	ON/OFF Delay Time	T_{on}	—	500	—	—	ms		
9	ON/OFF Off Time	T_{off}	—	500	—	—	ms		
10	PWM Signal Rising Time	T_{PWMR}	—	—	—	50	us		
11	PWM Signal Falling Time	T_{PWMF}	—	—	—	50	us		

Note (1) The power sequence and control signal timing are shown as the following figure 1.

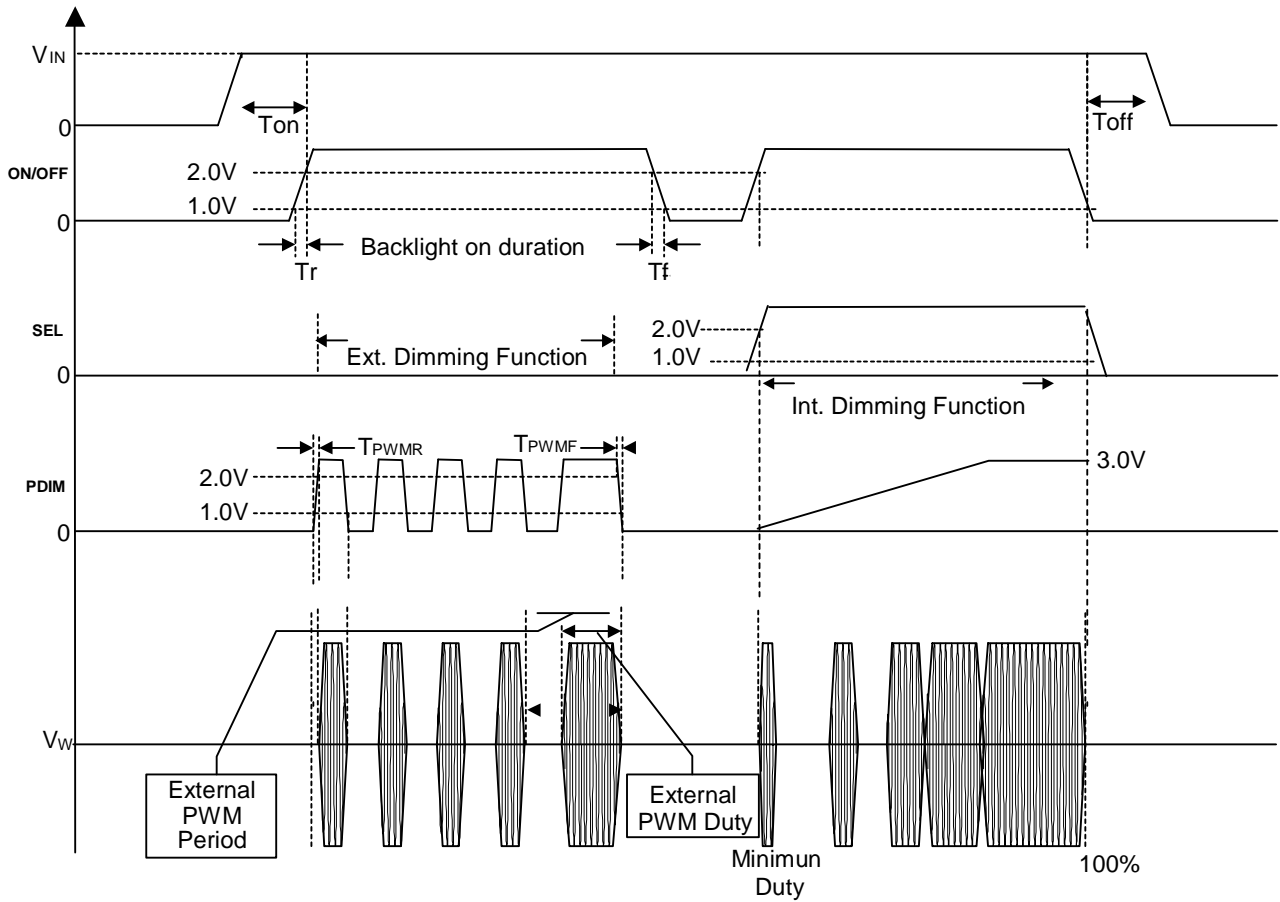
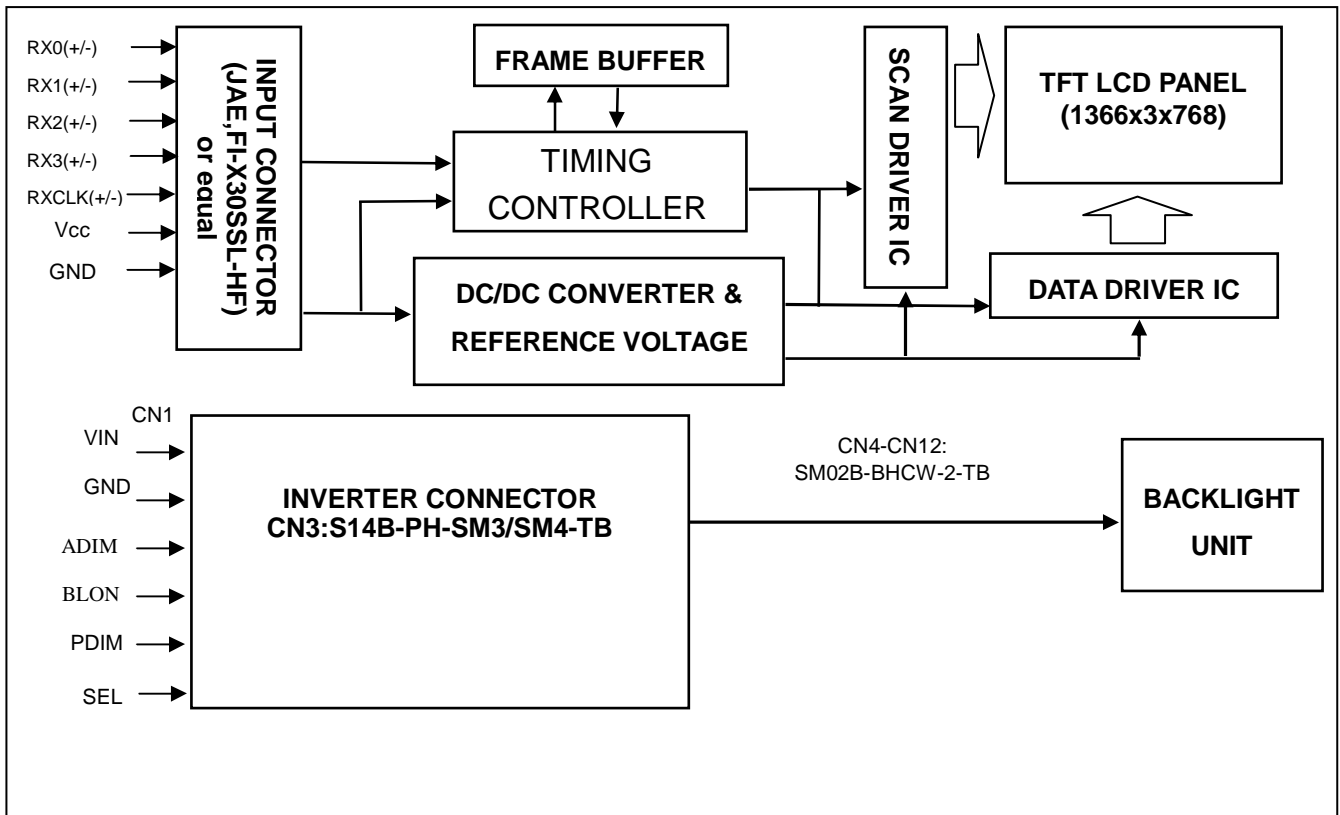

Figure 1

4. BLOCK DIAGRAM

4.1 TFT LCD MODULE



5. INTERFACE PIN CONNECTION

5.1 TFT LCD MODULE

CNF1 Connector Pin Assignment

Pin No.	Symbol	Description	Note
1	ODSEL	Overdrive Lookup Table Selection	(2)
2	RPF	Display Rotation	(3)
3	NC	No connection	(4)
4	GND	Ground	
5	RX0-	Negative transmission data of pixel 0	
6	RX0+	Positive transmission data of pixel 0	
7	GND	Ground	
8	RX1-	Negative transmission data of pixel 1	
9	RX1+	Positive transmission data of pixel 1	
10	GND	Ground	
11	RX2-	Negative transmission data of pixel 2	
12	RX2+	Positive transmission data of pixel 2	
13	GND	Ground	
14	RXCLK-	Negative of clock	
15	RXCLK+	Positive of clock	
16	GND	Ground	
17	RX3-	Negative transmission data of pixel 3	
18	RX3+	Positive transmission data of pixel 3	
19	GND	Ground	
20	NC	No connection	(4)
21	SELLVDS	Select LVDS data format	(5)
22	NC	No connection	(4)
23	GND	Ground	
24	GND	Ground	
25	GND	Ground	
26	VCC	Power supply: +5V	
27	VCC	Power supply: +5V	
28	VCC	Power supply: +5V	
29	VCC	Power supply: +5V	
30	VCC	Power supply: +5V	

Note (1) Connector Part No.: FI-X30SSL-HF(JAE).

Note (2) Overdrive lookup table selection. The Overdrive lookup table should be selected in accordance to the frame rate to optimize image quality.

ODSEL	Note
H or Open	Lookup table was optimized for 60 Hz frame rate.
L	Lookup table was optimized for 50 Hz frame rate.

Note (3) Low or open: normal display (default), High : display with 180 degree rotation

Note (4) Reserved for internal use. Left it open or connect to ground.

Note (5) Ground: Normal LVDS format, High or OPEN: JEIDA

Please refer to 5.5 LVDS INTERFACE (Page 19)

5.2 BACKLIGHT UNIT

The pin configuration for the housing and leader wire is shown in the table below.

CN4-CN11 (Housing): SM02B-BHCW-2-TB (LF) or equivalent

Pin No.	Symbol	Description	Wire Color
1	HV	High Voltage	White
2	HV	High Voltage	Pink

Note (1) The backlight interface housing for high voltage side is a model BHCR-02VS-3, manufactured by JST or equivalent. The mating header on inverter part number is SM02B-BHCW-2-TB (LF).

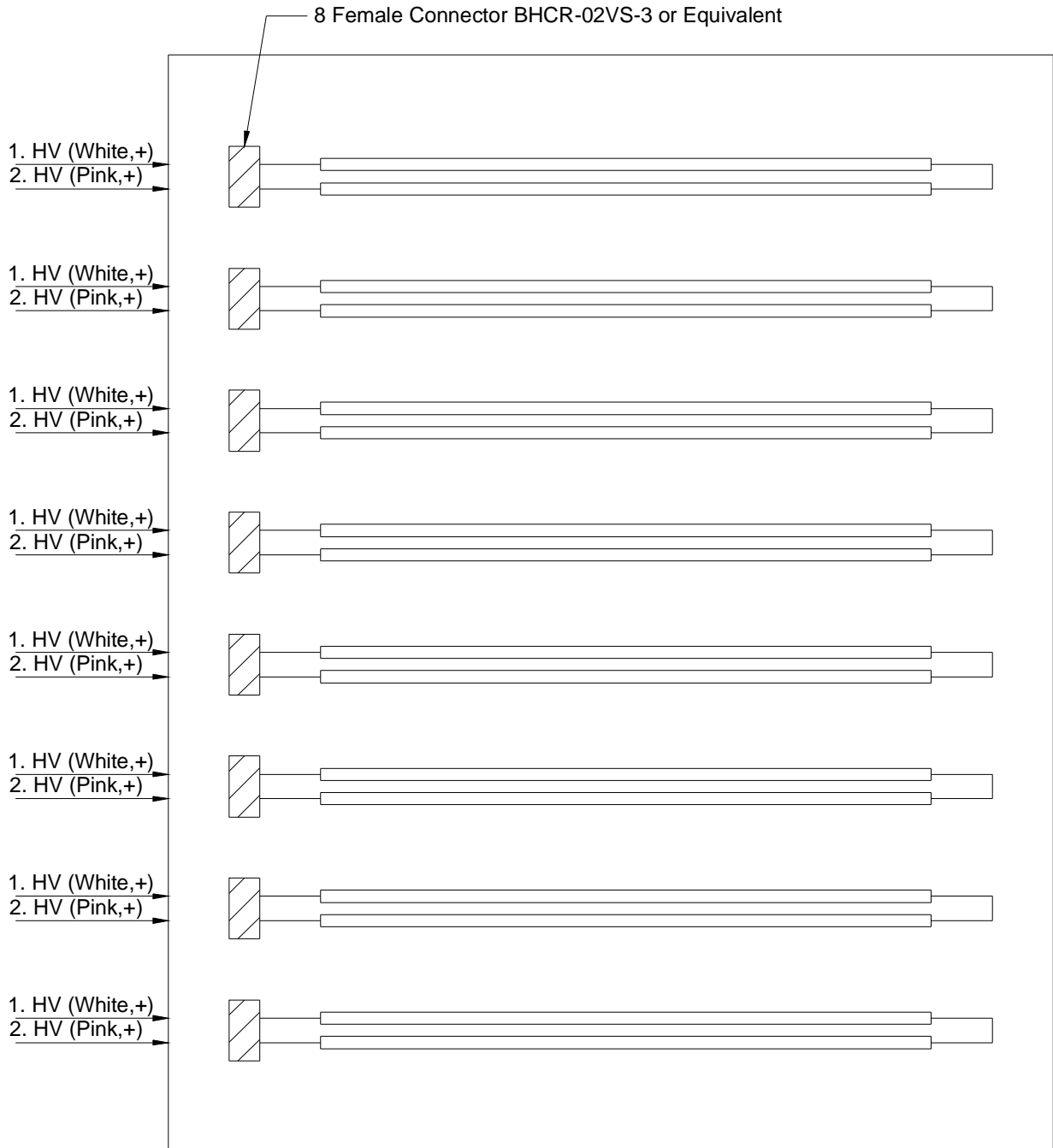

Front View

5.3 INVERTER UNIT

CN1(Header): S14B-PH-SM3-TB(D)(LF)(JST) or equivalent..

Pin No.	Symbol	Description
1	VIN	+24V Power input
2		
3		
4		
5		
6	GND	Ground
7		
8		
9		
10		
11	ADIM (1)	Analog Current Dimming Signal
12	ON/OFF	Backlight on/off control
13	PDIM (2)	PWM Dimming Signal
14	SEL(3)(4)	Open/High : internal dimming Low : external dimming

CN4-CN12 (Header): SM02B-BHCW-2-TB

Pin No.	Symbol	Description
1	CCFL HOT	CCFL high voltage
2	CCFL HOT	CCFL high voltage

Note (1) ADIM (amplitude dimming) is control signal for Inverter's output power to backlight lamp bulb.

Input signal should be able to control amplitude of Inverter output current. From 0V to 3.3V, Inverter output voltage should be able to vary to control brightness of lamp from 80% to 110% luminance variation. Approximate 1.6V might be 100% luminance control point.

Note (2) PDIM is PWM duty control input for +3.3V TTL level signal or DC voltage by Pin 14 input.

This input signal is (a) continuous pulse signal with +3.3V, TTL level signal spec, or (b) DC power with 0~3.3V. IF this is Open or +3.3V, 100% duty (i.e. +3.3V, DC level), backlight should perform 100% luminance. Duty ratio of this input signal should be proportional relationship in certain range of control without any kind of inherent side effect like waterfall effect on screen. Guaranteed duty range and dimming ratio should be specified with supplementary measurement result.

Note (3) Pin 14 is the selection pin for PWM control method; if this pin is connected to GND, PDIM

Input of Pin 13 should have logic level duty signal for PWM control. If this is set to High or Open, Pin 13 should have DC level signal therefore the Inverter should have Saw Tooth Wave Generator to generate internal PWM signal. Default setting is "Not Connected", Pin 13 of PWM control should have DC Level signal for PWM.

Note (4) Pin 14 selection vs. Pin 11/13 control function table:

	Pin 11 (DC Power Control Duty Amplitude) Function Always Turn On Default: Open/1.6V : 100%	Pin 13 Default: Open/High : 100%
Pin 14 = GND	GND: 80% ; Open/1.6V: 100% High (3.3V) 110%, Luminance	External PWM (AC Signal Control Duty)
Pin 14 = Open/High		Internal PWM (DC Power Control Duty)

5.4 BLOCK DIAGRAM OF INTERFACE

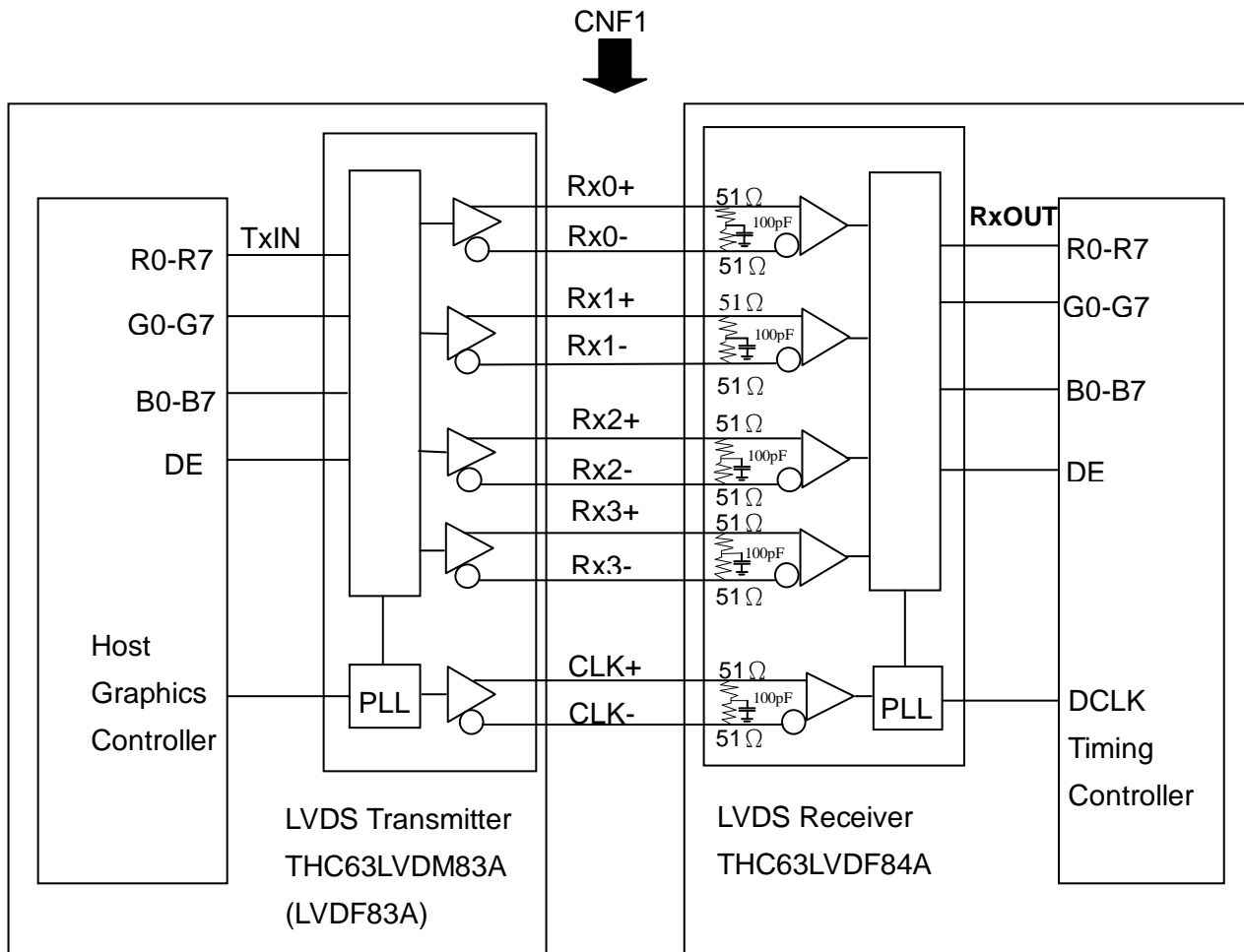

R0~R7 : Pixel R Data ,
 G0~G7 : Pixel G Data ,
 B0~B7 : Pixel B Data ,
 DE : Data enable signal

Note (1) The system must have the transmitter to drive the module.

Note (2) LVDS cable impedance shall be 50 ohms per signal line or about 100 ohms per twist-pair line when it is used differentially.

5.5 LVDS INTERFACE

	SIGNAL		TRANSMITTER THC63LVDM83A		INTERFACE CONNECTOR		RECEIVER THC63LVDF84A		TFT CONTROL INPUT			
	SELLVDS= L	SELLVDS= H or Open	PIN	INPUT	Host	TFT-LCD	PIN	OUTPUT	SELLVDS= L	SELLVDS= H or Open		
24 bit	R0	R2	51	TxIN0	TA OUT0+	Rx 0+	27	Rx OUT0	R0	R2		
	R1	R3	52	TxIN1			29	Rx OUT1	R1	R3		
	R2	R4	54	TxIN2			30	Rx OUT2	R2	R4		
	R3	R5	55	TxIN3			32	Rx OUT3	R3	R5		
	R4	R6	56	TxIN4			33	Rx OUT4	R4	R6		
	R5	R7	3	TxIN6			TA OUT0-	Rx 0-	35	Rx OUT6	R5	R7
	G0	G2	4	TxIN7					37	Rx OUT7	G0	G2
	G1	G3	6	TxIN8	38	Rx OUT8			G1	G3		
	G2	G4	7	TxIN9	TA OUT1+	Rx 1+	39	Rx OUT9	G2	G4		
	G3	G5	11	TxIN12			43	Rx OUT12	G3	G5		
	G4	G6	12	TxIN13			45	Rx OUT13	G4	G6		
	G5	G7	14	TxIN14			46	Rx OUT14	G5	G7		
	B0	B2	15	TxIN15	TA OUT1-	Rx 1-	47	Rx OUT15	B0	B2		
	B1	B3	19	TxIN18			51	Rx OUT18	B1	B3		
	B2	B4	20	TxIN19			53	Rx OUT19	B2	B4		
	B3	B5	22	TxIN20	TA OUT2+	Rx 2+	54	Rx OUT20	B3	B5		
	B4	B6	23	TxIN21			55	Rx OUT21	B4	B6		
	B5	B7	24	TxIN22			1	Rx OUT22	B5	B7		
	DE	DE	30	TxIN26			6	Rx OUT26	DE	DE		
	R6	R0	50	TxIN27	TA OUT2-	Rx 2-	7	Rx OUT27	R6	R0		
	R7	R1	2	TxIN5			34	Rx OUT5	R7	R1		
	G6	G0	8	TxIN10			41	Rx OUT10	G6	G0		
	G7	G1	10	TxIN11	TA OUT3+	Rx 3+	42	Rx OUT11	G7	G1		
	B6	B0	16	TxIN16			49	Rx OUT16	B6	B0		
B7	B1	18	TxIN17	50			Rx OUT17	B7	B1			
RSVD 1	RSVD 1	25	TxIN23	TA OUT3-	Rx 3-	2	Rx OUT23	NC	NC			
RSVD 2	RSVD 2	27	TxIN24			3	Rx OUT24	NC	NC			
RSVD 3	RSVD 3	28	TxIN25			5	Rx OUT25	NC	NC			
DCLK		31	TxCLK IN	TxCLK OUT+	RxCLK IN+	26	RxCLK	DCLK				
				TxCLK OUT-	RxCLK IN-		OUT					

R0~R7: Pixel R Data (7; MSB, 0; LSB)

G0~G7: Pixel G Data (7; MSB, 0; LSB)

B0~B7: Pixel B Data (7; MSB, 0; LSB)

DE: Data enable signal

Notes(1) RSVD(reserved)pins on the transmitter shall be "H" or ("L" or OPEN)

5.6 COLOR DATA INPUT ASSIGNMENT

The brightness of each primary color (red, green and blue) is based on the 8-bit gray scale data input for the color. The higher the binary input, the brighter the color. The table below provides the assignment of color versus data input.

Color		Data Signal																							
		Red								Green								Blue							
		R7	R6	R5	R4	R3	R2	R1	R0	G7	G6	G5	G4	G3	G2	G1	G0	B7	B6	B5	B4	B3	B2	B1	B0
Basic Colors	Black	0	0	0	0	0	0	0	0	0	0	0	0	0	0	0	0	0	0	0	0	0	0	0	
	Red	1	1	1	1	1	1	1	1	0	0	0	0	0	0	0	0	0	0	0	0	0	0	0	
	Green	0	0	0	0	0	0	0	0	1	1	1	1	1	1	1	1	0	0	0	0	0	0	0	
	Blue	0	0	0	0	0	0	0	0	0	0	0	0	0	0	0	0	1	1	1	1	1	1	1	
	Cyan	0	0	0	0	0	0	0	0	1	1	1	1	1	1	1	1	1	1	1	1	1	1	1	
	Magenta	1	1	1	1	1	1	1	1	0	0	0	0	0	0	0	0	1	1	1	1	1	1	1	
	Yellow	1	1	1	1	1	1	1	1	1	1	1	1	1	1	1	1	0	0	0	0	0	0	0	
	White	1	1	1	1	1	1	1	1	1	1	1	1	1	1	1	1	1	1	1	1	1	1	1	
Gray Scale Of Red	Red(0) / Dark	0	0	0	0	0	0	0	0	0	0	0	0	0	0	0	0	0	0	0	0	0	0		
	Red(1)	0	0	0	0	0	0	0	1	0	0	0	0	0	0	0	0	0	0	0	0	0	0		
	Red(2)	0	0	0	0	0	0	1	0	0	0	0	0	0	0	0	0	0	0	0	0	0	0		
	:	:	:	:	:	:	:	:	:	:	:	:	:	:	:	:	:	:	:	:	:	:	:		
	:	:	:	:	:	:	:	:	:	:	:	:	:	:	:	:	:	:	:	:	:	:	:		
	Red(253)	1	1	1	1	1	1	0	1	0	0	0	0	0	0	0	0	0	0	0	0	0	0		
	Red(254)	1	1	1	1	1	1	1	0	0	0	0	0	0	0	0	0	0	0	0	0	0	0		
	Red(255)	1	1	1	1	1	1	1	1	0	0	0	0	0	0	0	0	0	0	0	0	0	0		
Gray Scale Of Green	Green(0) / Dark	0	0	0	0	0	0	0	0	0	0	0	0	0	0	0	0	0	0	0	0	0	0		
	Green(1)	0	0	0	0	0	0	0	0	0	0	0	0	0	0	1	0	0	0	0	0	0	0		
	Green(2)	0	0	0	0	0	0	0	0	0	0	0	0	0	1	0	0	0	0	0	0	0	0		
	:	:	:	:	:	:	:	:	:	:	:	:	:	:	:	:	:	:	:	:	:	:	:		
	:	:	:	:	:	:	:	:	:	:	:	:	:	:	:	:	:	:	:	:	:	:	:		
	Green(253)	0	0	0	0	0	0	0	0	1	1	1	1	1	1	0	1	0	0	0	0	0	0		
	Green(254)	0	0	0	0	0	0	0	0	1	1	1	1	1	1	1	0	0	0	0	0	0	0		
	Green(255)	0	0	0	0	0	0	0	0	1	1	1	1	1	1	1	1	0	0	0	0	0	0		
Gray Scale Of Blue	Blue(0) / Dark	0	0	0	0	0	0	0	0	0	0	0	0	0	0	0	0	0	0	0	0	0	0		
	Blue(1)	0	0	0	0	0	0	0	0	0	0	0	0	0	0	0	0	0	0	0	0	0	1		
	Blue(2)	0	0	0	0	0	0	0	0	0	0	0	0	0	0	0	0	0	0	0	0	0	1		
	:	:	:	:	:	:	:	:	:	:	:	:	:	:	:	:	:	:	:	:	:	:	:		
	:	:	:	:	:	:	:	:	:	:	:	:	:	:	:	:	:	:	:	:	:	:	:		
	Blue(253)	0	0	0	0	0	0	0	0	0	0	0	0	0	0	0	0	1	1	1	1	1	0		
	Blue(254)	0	0	0	0	0	0	0	0	0	0	0	0	0	0	0	0	1	1	1	1	1	0		
	Blue(255)	0	0	0	0	0	0	0	0	0	0	0	0	0	0	0	0	1	1	1	1	1	1		

Note (1) 0: Low Level Voltage, 1: High Level Voltage

6. INTERFACE TIMING

6.1 INPUT SIGNAL TIMING SPECIFICATIONS

The input signal timing specifications are shown as the following table and timing diagram.

Signal	Item	Symbol	Min.	Typ.	Max.	Unit	Note
LVDS Receiver Clock	Frequency	1/Tc	60	86	88	MHZ	
	Input cycle to cycle jitter	Trcl	-	-	200	ps	
LVDS Receiver Data	Setup Time	Tlvsu	400	-	-	ps	
	Hold Time	Tlvhd	400	-	-	ps	
Vertical Active Display Term	Frame Rate	Fr5	47	50	53	Hz	(2)
		Fr6	57	60	63	Hz	
	Total	Tv	778	795	980	Th	Tv=Tvd+Tvb
	Display	Tvd	768	768	768	Th	-
	Blank	Tvb	10	27	212	Th	-
Horizontal Active Display Term	Total	Th	1442	1798	1936	Tc	Th=Thd+Thb
	Display	Thd	1366	1366	1366	Tc	-
	Blank	Thb	76	432	570	Tc	-

Note (1) Since this module is operated in DE only mode, Hsync and Vsync input signals should be set to low logic level. Otherwise, this module would operate abnormally.

(2) Please refer to 5.1 for detail information.

INPUT SIGNAL TIMING DIAGRAM

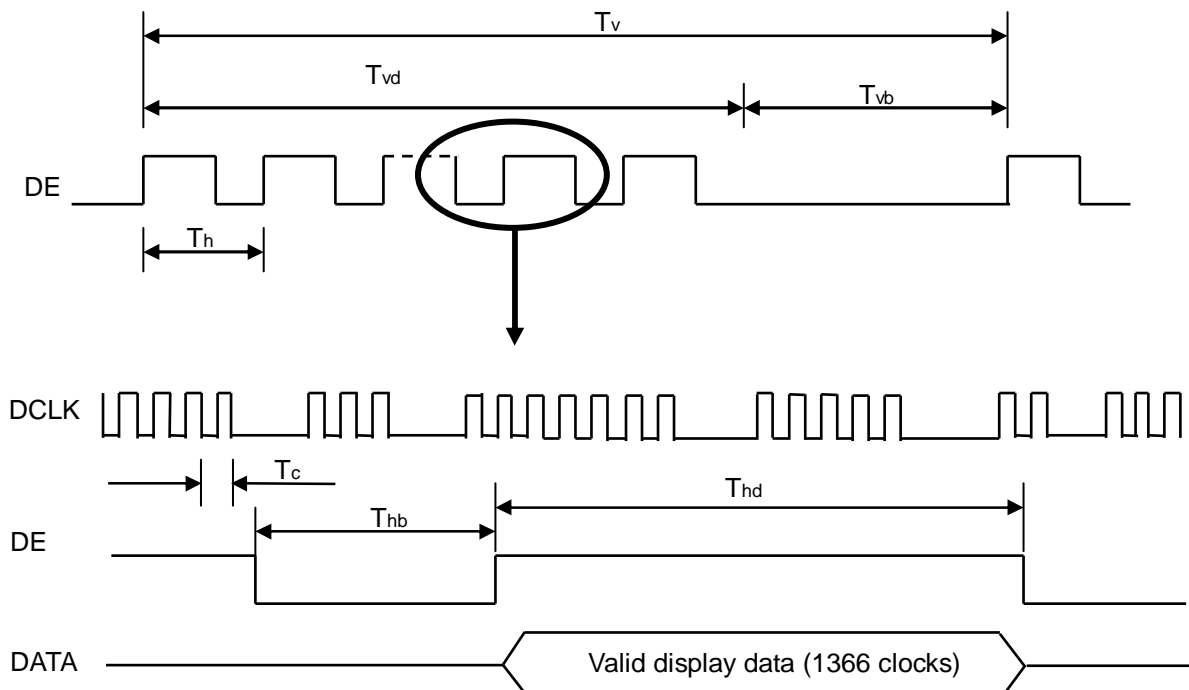

LVDS RECEIVER INTERFACE TIMING DIAGRAM

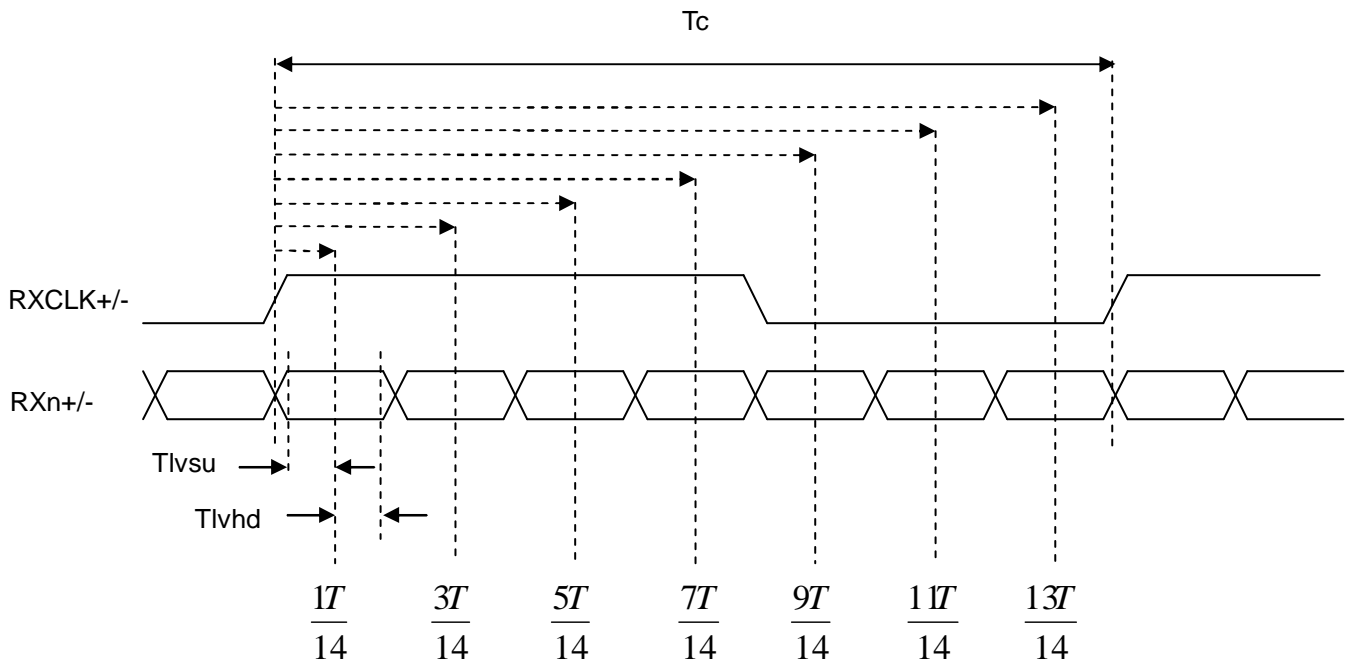

6.2 POWER ON/OFF SEQUENCE

To prevent a latch-up or DC operation of LCD module, the power on/off sequence should be as the diagram below.

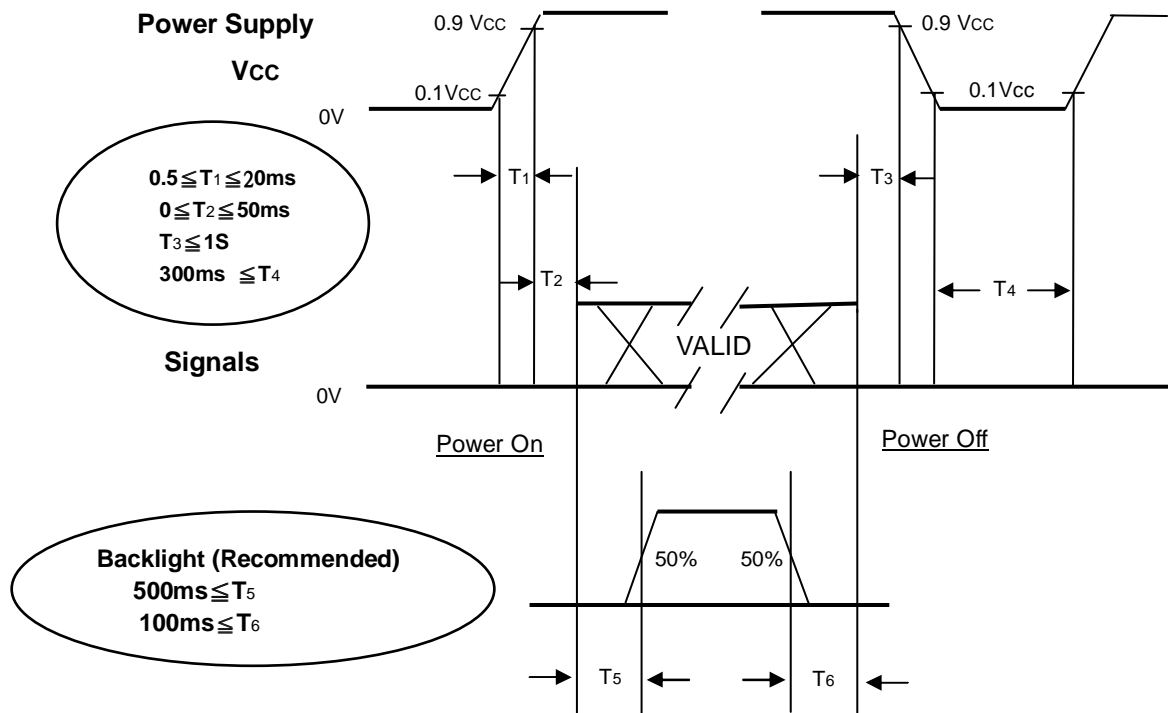

Power ON/OFF Sequence

Note (1) The supply voltage of the external system for the module input should follow the definition of Vcc.

Note (2) Apply the lamp voltage within the LCD operation range. When the backlight turns on before the LCD operation or the LCD turns off before the backlight turns off, the display may momentarily become abnormal screen.

Note (3) In case of Vcc is in off level, please keep the level of input signals on the low or high impedance.

Note (4) T4 should be measured after the module has been fully discharged between power off and on period.

Note (5) Interface signal shall not be kept at high impedance when the power is on.

7. OPTICAL CHARACTERISTICS

7.1 TEST CONDITIONS

Item	Symbol	Value	Unit
Ambient Temperature	Ta	25±2	°C
Ambient Humidity	Ha	50±10	%RH
Supply Voltage	V _{CC}	5.0	V
Input Signal	According to typical value in "3. ELECTRICAL CHARACTERISTICS"		
Lamp Current	I _L	5.0 ± 0.5	mA
Oscillating Frequency (Inverter)	F _w	41±2	KHz
Frame rate		60	Hz

7.2 OPTICAL SPECIFICATIONS

The relative measurement methods of optical characteristics are shown in 7.2. The following items should be measured under the test conditions described in 7.1 and stable environment shown in Note (5).

Item	Symbol	Condition	Min.	Typ.	Max.	Unit	Note
Contrast Ratio	CR	$\theta_x=0^\circ, \theta_y=0^\circ$ Viewing Normal Angle	1200	1500	-	-	Note(2) Note(5)
Response Time	Gray to gray average		-	6.5	12	ms	Note(3)
Center Luminance of White	L _c		400	500	-	cd/m ²	Note(4) Note(5)
White Variation	δW		-	-	1.3	-	Note(5) Note(6)
Color Chromaticity	Red	R _x	Typ.-0.03	0.643	Typ.+0.03	-	Note(5)
		R _y		0.333		-	
	Green	G _x		0.272		-	
		G _y		0.595		-	
	Blue	B _x		0.144		-	
		B _y		0.069		-	
	White	W _x		0.280		-	
		W _y		0.285		-	
Color Gamut	CG	80	85		%	CIE1976 NTSC	
Viewing Angle	Horizontal	θ_{x+}	80	88	-	Deg.	Note(1)
		θ_{x-}	80	88	-		
	Vertical	θ_{y+}	80	88	-		
		θ_{y-}	80	88	-		

Note (1) Definition of Viewing Angle (θ_x, θ_y):

Viewing angles are measured by EZ-Contrast 160R (Eldim)

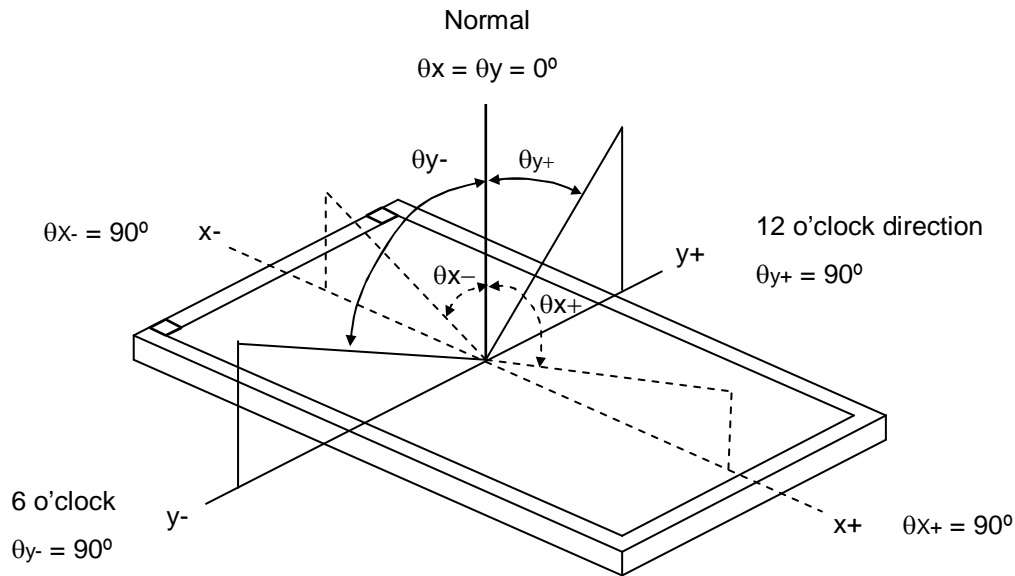

Note (2) Definition of Contrast Ratio (CR):

The contrast ratio can be calculated by the following expression.

$$\text{Contrast Ratio (CR)} = L_{255} / L_0$$

L255: Luminance of gray level 255

L 0: Luminance of gray level 0

CR = CR (X), where CR (X) is corresponding to the Contrast Ratio of the point X at the figure in Note (6).

Note (3) Definition of Gray to Gray Switching Time :

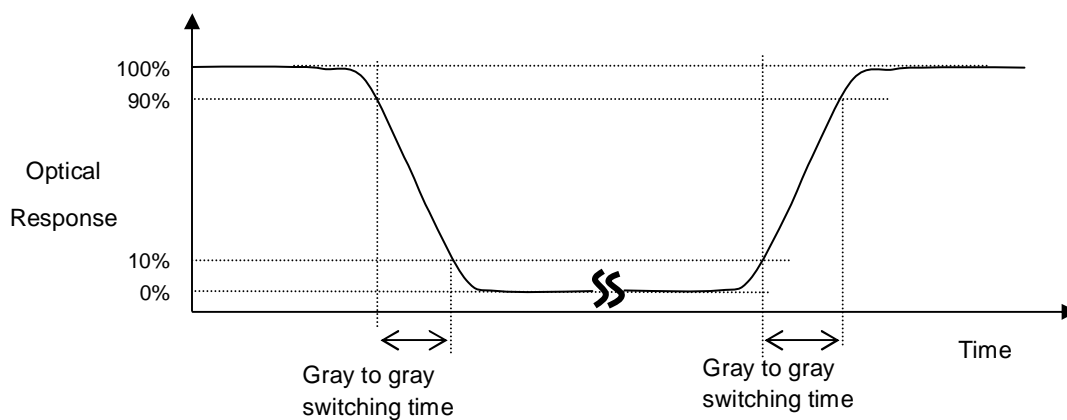

The driving signal means the signal of luminance 0%, 20%, 40%, 60%, 80%, 100%.

Gray to gray average time means the average switching time of luminance 0%, 20%, 40%, 60%, 80%, 100% to each other.

Note (4) Definition of Luminance of White (L_C):

Measure the luminance of gray level 255 at center point

$$L_C = L(5)$$

where $L(x)$ is corresponding to the luminance of the point X at the figure in Note (6).

Note (5) Measurement Setup:

The LCD module should be stabilized at given temperature for 1 hour to avoid abrupt temperature change during measuring. In order to stabilize the luminance, the measurement should be executed after lighting Backlight for 1 hour in a windless room.

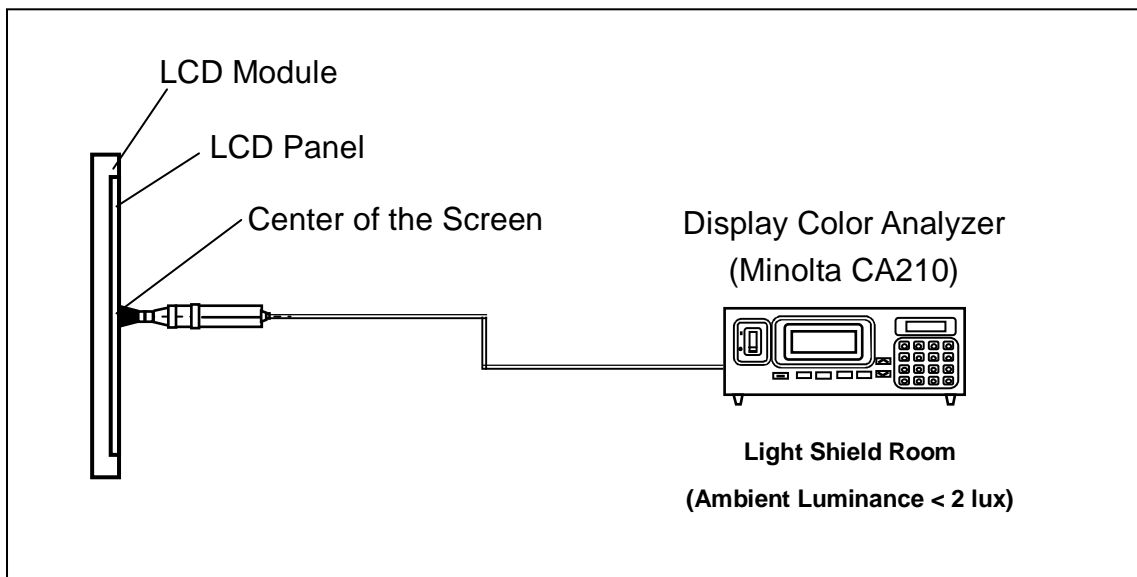

Note (6) Definition of White Variation (δW):

Measure the luminance of gray level 255 at 5 points

$$\delta W = \text{Maximum} [L(1), L(2), L(3), L(4), L(5)] / \text{Minimum} [L(1), L(2), L(3), L(4), L(5)]$$

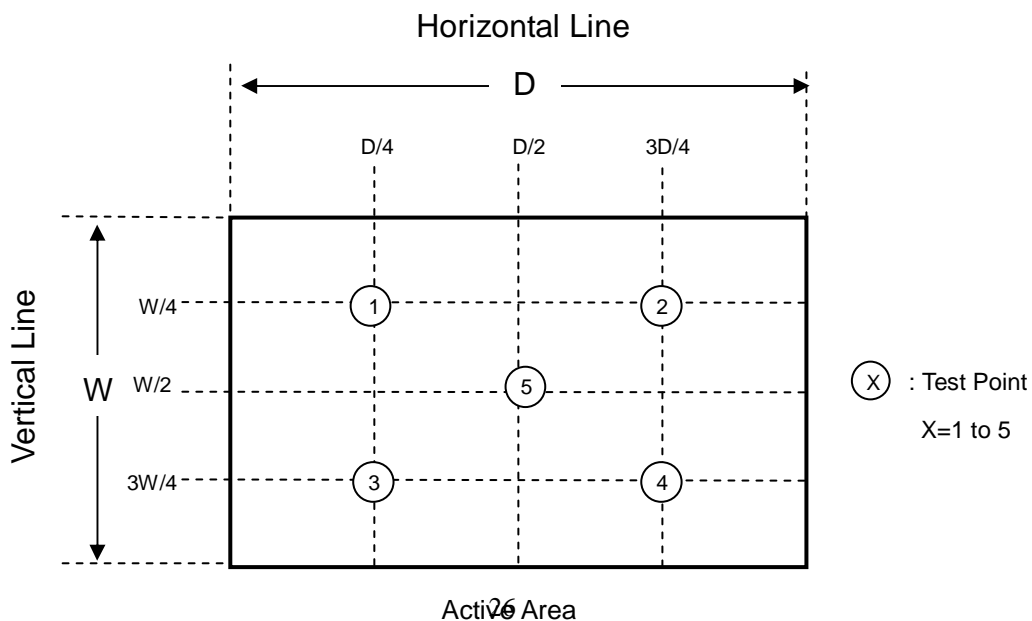

8. DEFINITION OF LABELS

8.1 CMO MODULE LABEL

The barcode nameplate is pasted on each module as illustration, and its definitions are as following explanation.

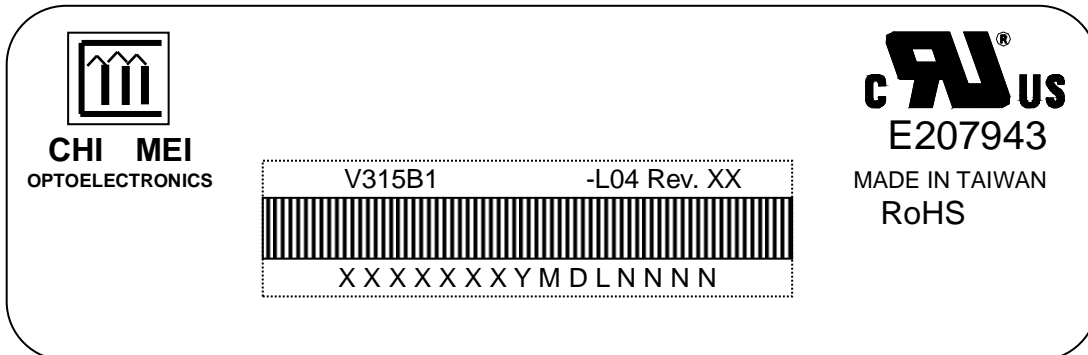

- (a) Model Name: V315B1-L04
- (b) Revision: Rev. XX, for example: A0, A1... B1, B2... or C1, C2...etc.
- (c) Serial ID: X X X X X X Y M D L N N N N

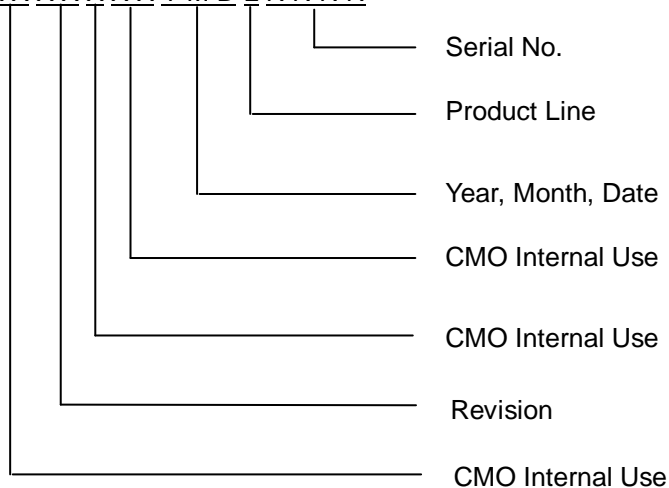

Serial ID includes the information as below:

- (a) Manufactured Date: Year: 0~9, for 2000~2009
 Month: 1~9, A~C, for Jan. ~ Dec.
 Day: 1~9, A~Y, for 1st to 31st, exclude I ,O, and U.
- (b) Revision Code: Cover all the change
- (c) Serial No.: Manufacturing sequence of product
- (d) Product Line: 1 -> Line1, 2 -> Line 2, ...etc.

9. PACKAGING

9.1 PACKING SPECIFICATIONS

- (1) 5 LCD TV modules / 1 Box
- (2) Box dimensions : 834(L) X 380 (W) X 530 (H)
- (3) Weight : approximately 38.5Kg (5 modules per box)

9.2 PACKING METHOD

Figures 9-1 and 9-2 are the packing method

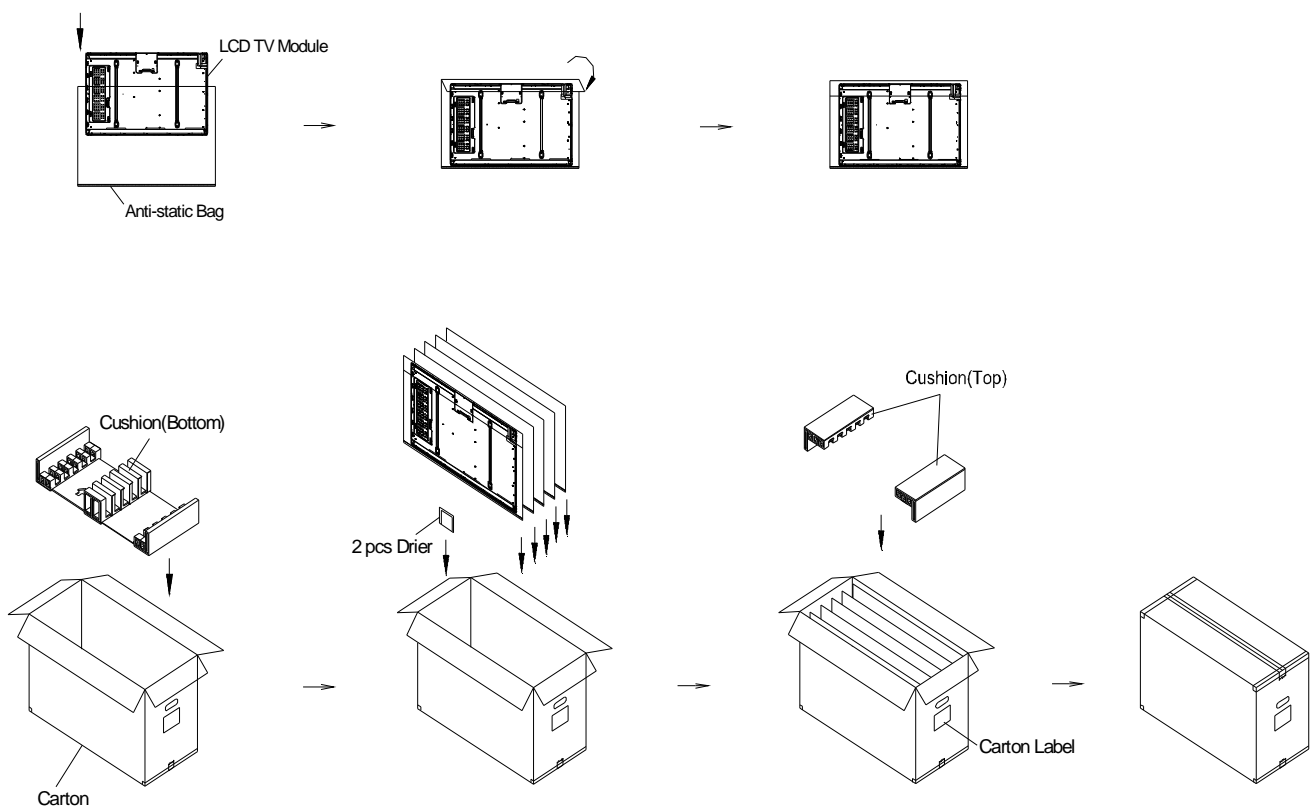
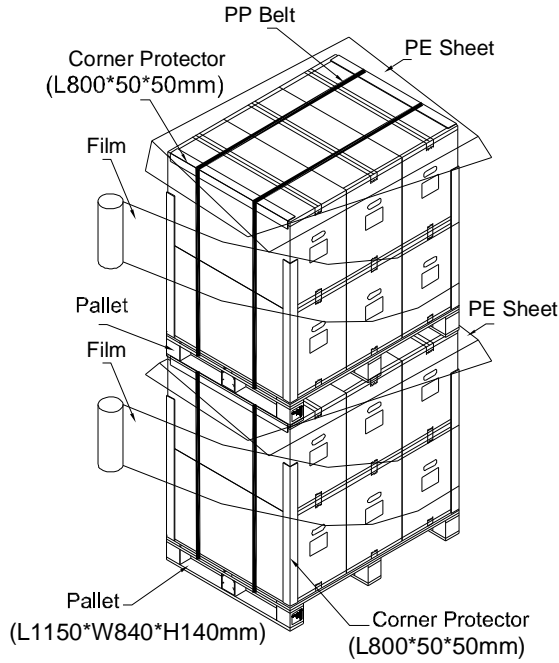
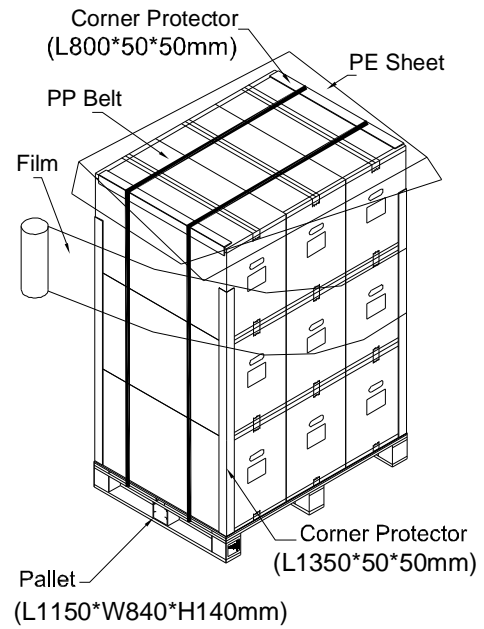

Figure.9-1 packing method

Sea / Land Transportation
(40ft HQ Container)



Sea / Land Transportation
(40ft Container)



Air Transportation

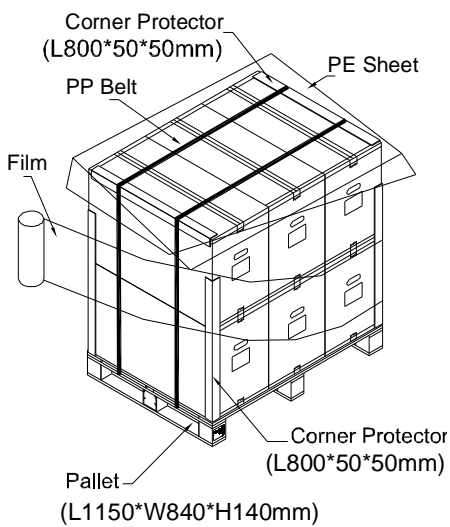

Figure.9-2 packing method

10. PRECAUTIONS

10.1 ASSEMBLY AND HANDLING PRECAUTIONS

- (1) Do not apply rough force such as bending or twisting to the module during assembly.
- (2) It is recommended to assemble or to install a module into the user's system in clean working areas.
The dust and oil may cause electrical short or worsen the polarizer.
- (3) Do not apply pressure or impulse to the module to prevent the damage of LCD panel and backlight.
- (4) Always follow the correct power-on sequence when the LCD module is turned on. This can prevent the damage and latch-up of the CMOS LSI chips.
- (5) Do not plug in or pull out the I/F connector while the module is in operation.
- (6) Do not disassemble the module.
- (7) Use a soft dry cloth without chemicals for cleaning, because the surface of polarizer is very soft and easily scratched.
- (8) Moisture can easily penetrate into LCD module and may cause the damage during operation.
- (9) High temperature or humidity may deteriorate the performance of LCD module. Please store LCD modules in the specified storage conditions.
- (10) When ambient temperature is lower than 10°C, the display quality might be reduced. For example, the response time will become slow, and the starting voltage of CCFL will be higher than that of room temperature.

10.2 SAFETY PRECAUTIONS

- (1) The startup voltage of a backlight is over 1000 Volts. It may cause an electrical shock while assembling with the inverter. Do not disassemble the module or insert anything into the backlight unit.
- (2) If the liquid crystal material leaks from the panel, it should be kept away from the eyes or mouth. In case of contact with hands, skin or clothes, it has to be washed away thoroughly with soap.
- (3) After the module's end of life, it is not harmful in case of normal operation and storage.

11. REGULATORY STANDARDS

11.1 Safety

Regulatory	Item	Standard
Audio/Video Apparatus	UL	UL 60065: 2003
	cUL	CAN/CSA C22.2 No.60065-03
	CB	IEC 60065:2001

11.2 EMC

- (1) FCC class B part15
- (2) CISPR20

Note (1) CMO product can support to meet FCC class B part15 and CISPR20 standard

12. MECHANICAL CHARACTERISTICS

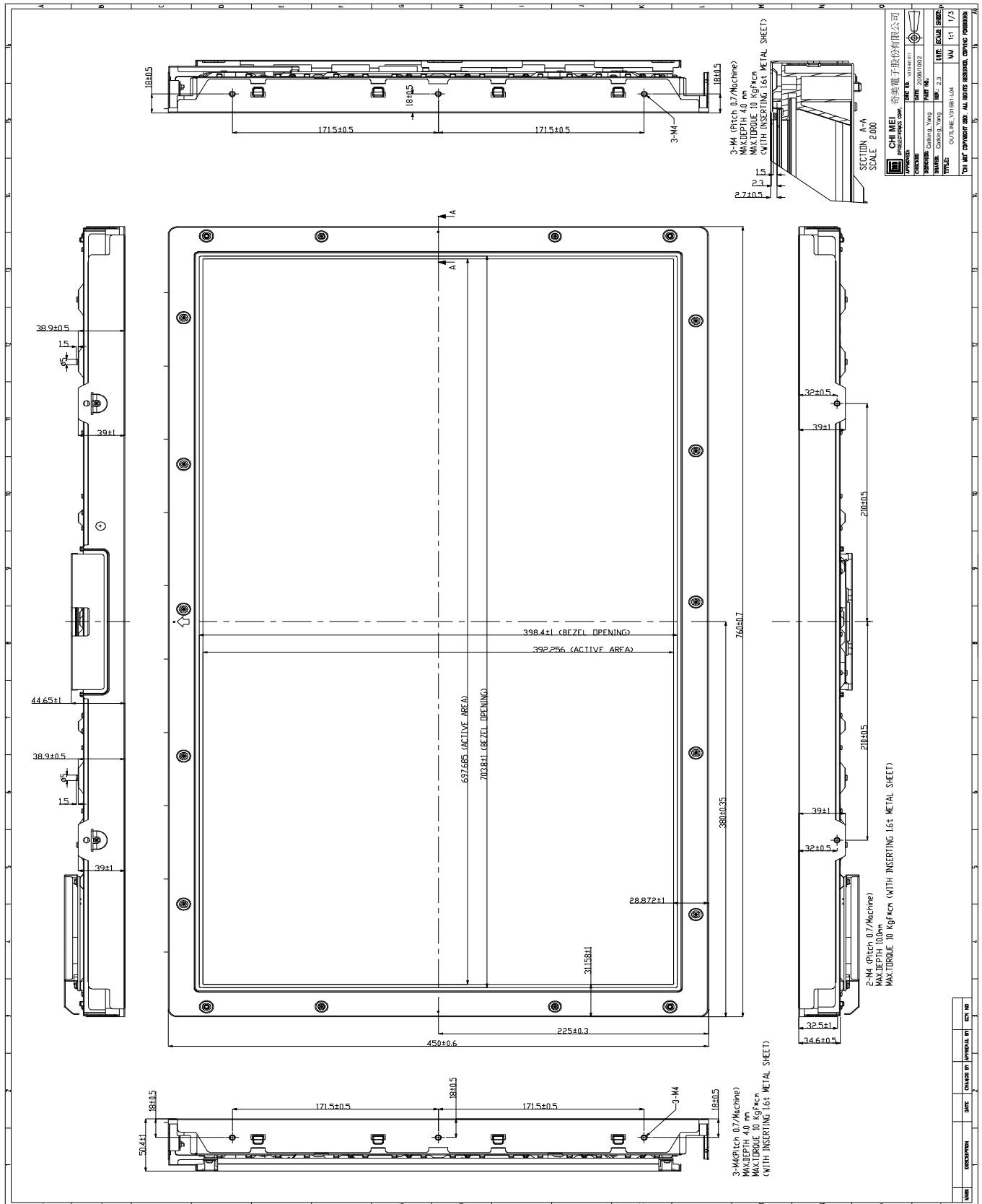



Approval

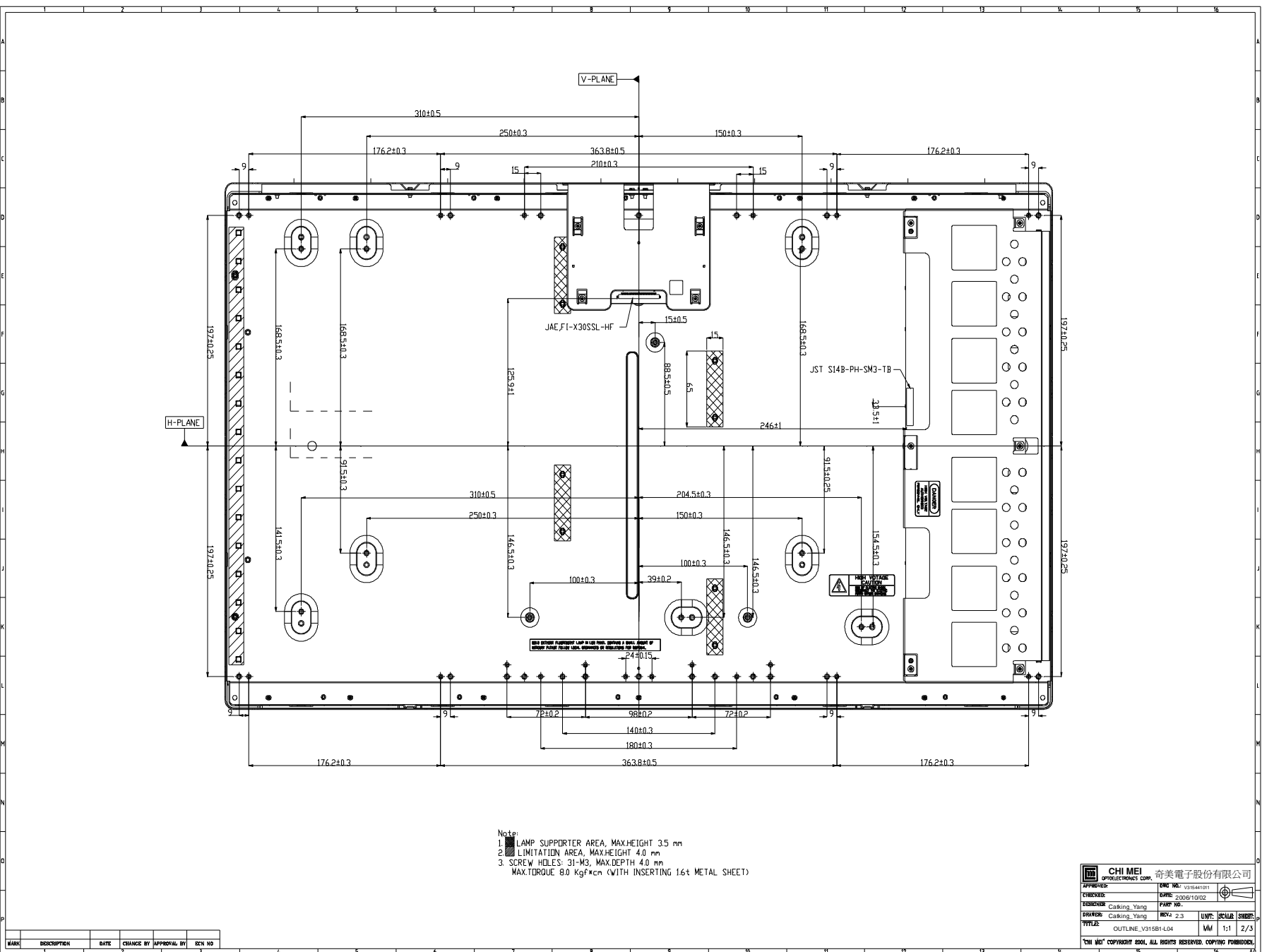



Approval

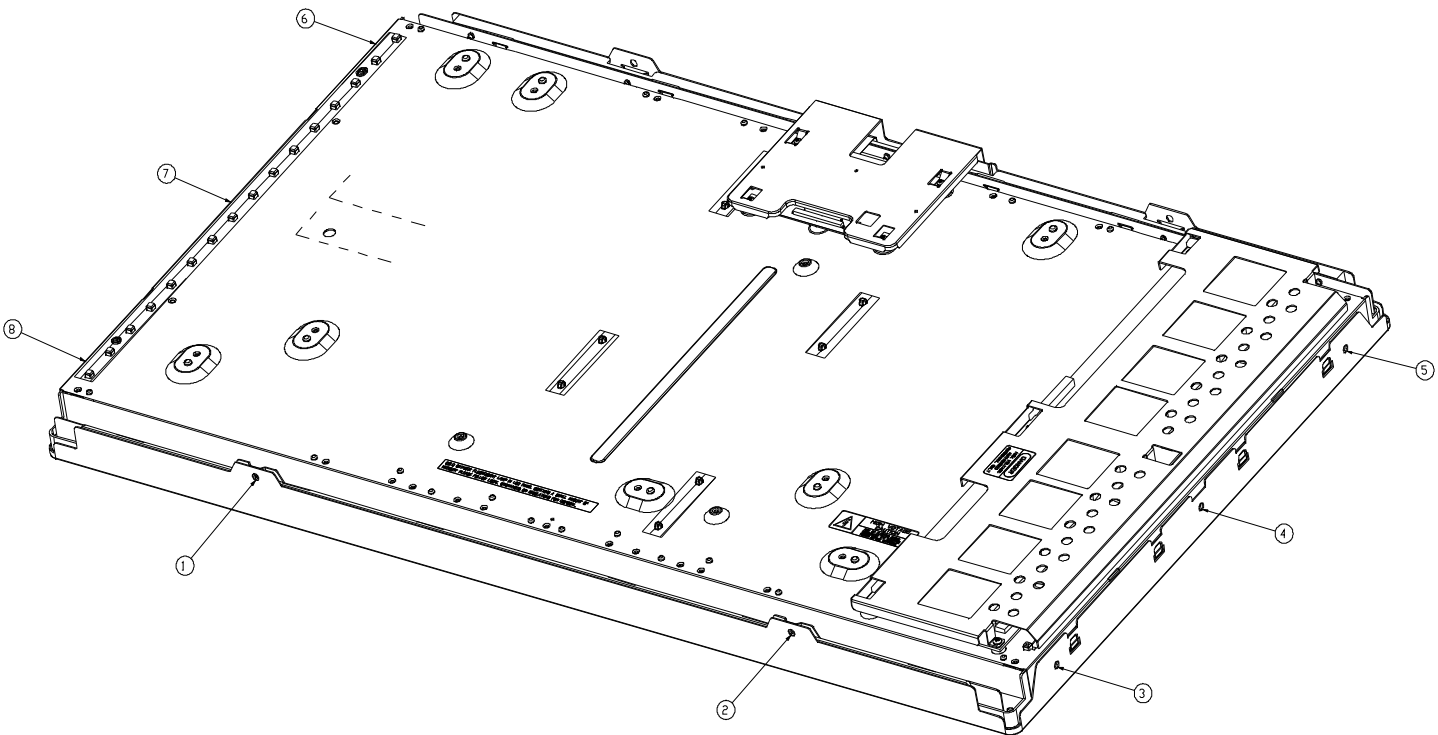

Case1. It is recommended that Balloon 1-8 screws should be included when CMI's product is applied in order to guarantee structure strength of product

CHI MEI 奇美電子股份有限公司 OPTOELECTRONICS CORP.		DWG NO.: V315B1/011	
DATE:	2006/10/02	SCALE:	1:1
DESIGNED: Catking_Yang	DATE:	REV.:	2.3
DRAWN: Catking_Yang	DATE:	UNIT:	MM
TITLE: OUTLINE_V315B1-L04	DATE:	SCALE:	1:f
CHI MEI' COPYRIGHT 2004. ALL RIGHTS RESERVED. COPYING PROHIBITED.		SHEET:	3/3

MARK	DESCRIPTION	DATE	CHANGE BY	APPROVAL BY	EXH. NO.