

## TFT LCD Approval Specification

# MODEL NO.: V315B1 - L05

RoHS Verified

Customer: _____  Approved by: _____  Note:
--

Approved By	TVHD	
	LY Chen	

Reviewed By	QRA Dept.	Product Development Div.
	Tomy Chen	WT Lin

Prepared By	LCD TV Marketing and Product Management Div.	
	Jiayu Weng	Mingcho Tsou

## - CONTENTS -

REVISION HISTORY	-----	3
1. GENERAL DESCRIPTION	-----	5
1.1 OVERVIEW		
1.2 FEATURES		
1.3 APPLICATION		
1.4 GENERAL SPECIFICATIONS		
1.5 MECHANICAL SPECIFICATIONS		
2. ABSOLUTE MAXIMUM RATINGS	-----	6
2.1 ABSOLUTE RATINGS OF ENVIRONMENT		
2.2 PACKAGE STORAGE		
2.3 ELECTRICAL ABSOLUTE RATINGS		
2.3.1 TFT LCD MODULE		
2.3.2 BACKLIGHT UNIT		
3. ELECTRICAL CHARACTERISTICS	-----	8
3.1 TFT LCD MODULE		
3.2 BACKLIGHT INVERTER UNIT		
3.2.1 CCFL(Cold Cathode Fluorescent Lamp) CHARACTERISTICS		
3.2.2 INVERTER CHARACTERISTICS		
3.2.3 INVERTER INTERFACE CHARACTERISTICS		
4. BLOCK DIAGRAM	-----	14
4.1 TFT LCD MODULE		
5. INTERFACE PIN CONNECTION	-----	15
5.1 TFT LCD MODULE		
5.2 BACKLIGHT UNIT		
5.3 INVERTER UNIT		
5.4 BLOCK DIAGRAM OF INTERFACE		
5.5 LVDS INTERFACE		
5.6 COLOR DATA INPUT ASSIGNMENT		
6. INTERFACE TIMING	-----	21
6.1 INPUT SIGNAL TIMING SPECIFICATIONS		
6.2 POWER ON/OFF SEQUENCE		
7. OPTICAL CHARACTERISTICS	-----	24
7.1 TEST CONDITIONS		
7.2 OPTICAL SPECIFICATIONS		
8. DEFINITION OF LABELS	-----	28
8.1 CMO MODULE LABEL		
9. PACKAGING	-----	29
9.1 PACKING SPECIFICATIONS		
9.2 PACKING METHOD		
10. PRECAUTIONS	-----	31
10.1 ASSEMBLY AND HANDLING PRECAUTIONS		
10.2 SAFETY PRECAUTIONS		
11. REGULATORY STANDARDS	-----	31
11.1 SAFETY		

---

12. MECHANICAL CHARACTERISTICS	-----	32
13. APPENDIX	-----	35

**REVISION HISTORY**

Version	Date	Page (New)	Section	Description
Ver 2.0	Jan. 31,'07	All	All	Approval Specification was first issued.

## 1. GENERAL DESCRIPTION

### 1.1 OVERVIEW

V315B1- L05 is a 31.5" TFT Liquid Crystal Display module with 16-CCFL Backlight unit and 1ch-LVDS interface. This module supports 1366 x 768 WXGA format and can display true 16.7M colors ( 8-bit colors). The inverter module for backlight is built-in.

### 1.2 FEATURES

- High brightness (500 nits)
- Ultra-high contrast ratio (1500:1)
- Faster response time (gray to gray average 8.5ms)
- High color saturation NTSC 72%
- Ultra wide viewing angle : 176(H)/176(V) (CR>20) with Super MVA technology
- DE (Data Enable) only mode
- LVDS (Low Voltage Differential Signaling) interface
- 180 degree rotation display (option)
- Color reproduction (nature color)
- Low color shift function
- RoHS Compliance

### 1.3 APPLICATION

- TFT LCD TVs
- Multi-Media Display

### 1.4 GENERAL SPECIFICATIONS

Item	Specification	Unit	Note
Active Area	697.6845 (H) x 392.256 (V) (31.51" diagonal)	mm	(1)
Bezel Opening Area	703.8 (H) x 398.4 (V)	mm	
Driver Element	a-si TFT active matrix	-	
Pixel Number	1366 x R.G.B. x 768	pixel	
Pixel Pitch (Sub Pixel)	1.53225 (H) x 0.51075 (V)	mm	
Pixel Arrangement	RGB vertical stripe	-	
Display Colors	16.7M	color	
Display Operation Mode	Transmissive mode / Normally black	-	
Surface Treatment	Anti-Glare coating (Haze 25%),Hard coating (3H)	-	

### 1.5 MECHANICAL SPECIFICATIONS

Item	Min.	Typ.	Max.	Unit	Note	
Module Size	Horizontal(H)	759	760	761	mm	(1)
	Vertical(V)	449	450	451	mm	(1)
	Depth(D)	36.95	37.95	38.95	mm	To PCB cover
	Depth(D)	46.4	47.4	48.4	mm	To inverter cover
Weight	6300	6500	6700	g		

Note (1) Please refer to the attached drawings for more information of front and back outline dimensions.

## 2. ABSOLUTE MAXIMUM RATINGS

### 2.1 ABSOLUTE RATINGS OF ENVIRONMENT

Item	Symbol	Value		Unit	Note
		Min.	Max.		
Storage Temperature	T <sub>ST</sub>	-20	+60	°C	(1)
Operating Ambient Temperature	T <sub>OP</sub>	0	+50	°C	(1), (2)
Shock (Non-Operating)	S <sub>NOF</sub>	-	100	G	(3), (5)
Vibration (Non-Operating)	V <sub>NOF</sub>	-	1.0	G	(4), (5)

Note (1) Temperature and relative humidity range is shown in the figure below.

(a) 90 %RH Max. ( $T_a \leq 40$  °C).

(b) Wet-bulb temperature should be 39 °C Max. ( $T_a > 40$  °C).

(c) No condensation.

Note (2) The maximum operating temperature is based on the test condition that the surface temperature of display area is less than or equal to 65 °C with LCD module alone in a temperature controlled chamber. Thermal management should be considered in final product design to prevent the surface temperature of display area from being over 65 °C. The range of operating temperature may degrade in case of improper thermal management in final product design.

Note (3) 2 ms, half sine wave, 1 time for  $\pm X$ ,  $\pm Y$ ,  $\pm Z$ .

Note (4) 10 ~ 200 Hz, 10 min, 1 time each X, Y, Z.

Note (5) At testing Vibration and Shock, the fixture in holding the module has to be hard and rigid enough so that the module would not be twisted or bent by the fixture.

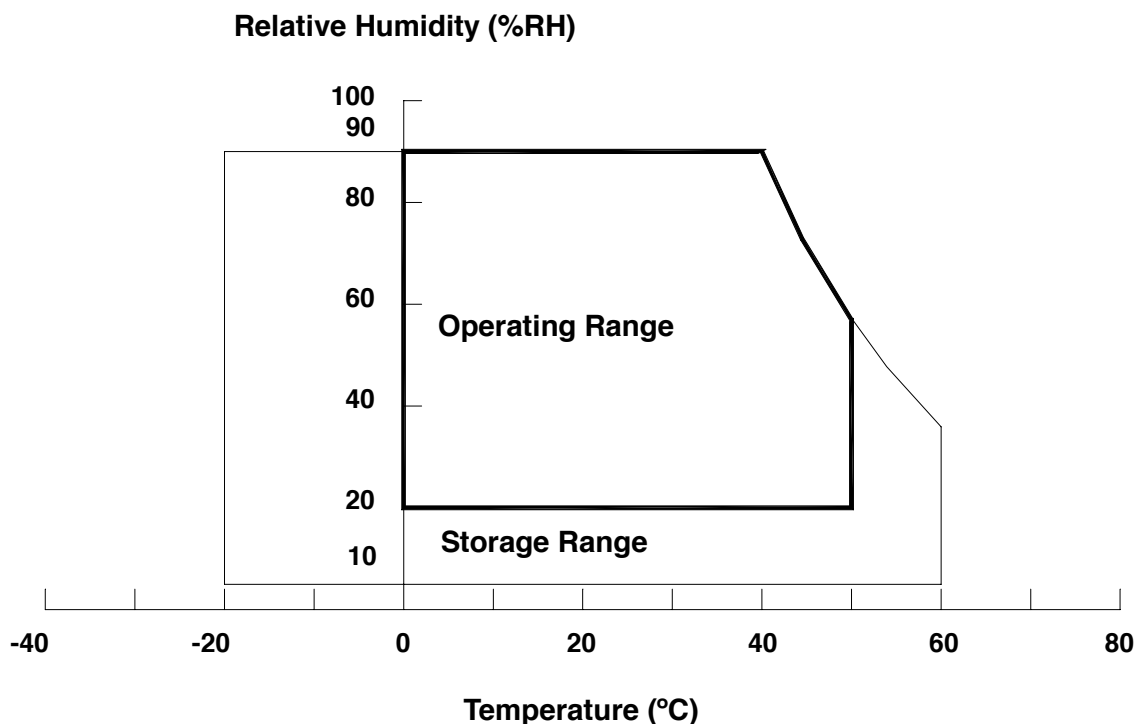

## 2.2 PACKAGE STORAGE

When storing modules as spares for a long time, the following precaution is necessary.

- (a) Do not leave the module in high temperature, and high humidity for a long time. It is highly recommended to store the module with temperature from 0 to 35°C at normal humidity without condensation.
- (b) The module shall be stored in dark place. Do not store the TFT-LCD module in direct sunlight or fluorescent light.

## 2.3 ELECTRICAL ABSOLUTE RATINGS

### 2.3.1 TFT LCD MODULE

Item	Symbol	Value		Unit	Note
		Min.	Max.		
Power Supply Voltage	V <sub>CC</sub>	-0.3	13.0	V	(1)
Input Signal Voltage	V <sub>IN</sub>	-0.3	3.6	V	

### 2.3.2 BACKLIGHT UNIT

Item	Symbol	Value		Unit	Note
		Min.	Max.		
Lamp Voltage	V <sub>W</sub>	—	3000	V <sub>RMS</sub>	
Power Supply Voltage	V <sub>BL</sub>	0	30	V	(1)
Control Signal Level	—	-0.3	7	V	(1), (3)

Note (1) Permanent damage to the device may occur if maximum values are exceeded. Functional operation should be restricted to the conditions described under normal operating conditions.

Note (2) No moisture condensation or freezing.

Note (3) The control signals includes Backlight On/Off Control, ADIM, PDIM.

### 3. ELECTRICAL CHARACTERISTICS

#### 3.1 TFT LCD MODULE

Ta = 25 ± 2 °C

Parameter	Symbol	Value			Unit	Note	
		Min.	Typ.	Max.			
Power Supply Voltage	V <sub>CC</sub>	11.4	12.0	12.6	V	(1)	
Power Supply Ripple Voltage	V <sub>RP</sub>	-	-	300	mV		
Rush Current	I <sub>RUSH</sub>	-	-	2.3	A	(2)	
Power Supply Current	White	I <sub>CC</sub>	-	0.63	0.80	A	(3)
	Black		-	0.30	-	A	
	Vertical Stripe		-	0.58	-	A	
LVDS Interface	Differential Input High Threshold Voltage	V <sub>LVTH</sub>	-	-	+100	mV	
	Differential Input Low Threshold Voltage	V <sub>LVTL</sub>	-100	-	-	mV	
	Common Input Voltage	V <sub>LVC</sub>	1.125	1.25	1.375	V	
	Terminating Resistor	R <sub>T</sub>	-	100	-	ohm	
CMOS interface	Input High Threshold Voltage	V <sub>IH</sub>	2.7	-	3.3	V	
	Input Low Threshold Voltage	V <sub>IL</sub>	0	-	0.7	V	

Note (1) The module should be always operated within above ranges.

Note (2) Measurement Conditions:

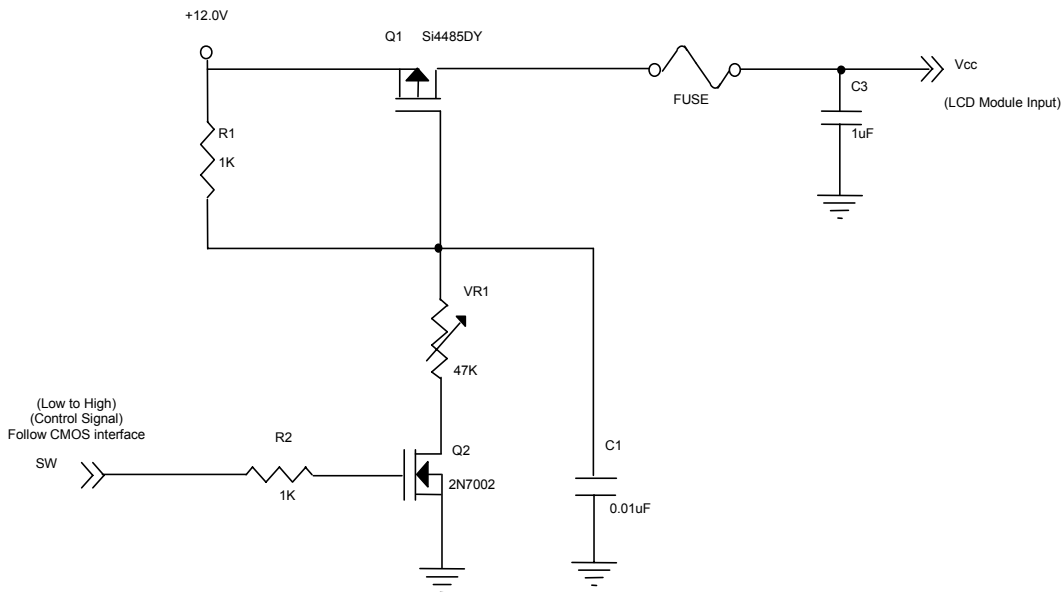

**Vcc rising time is 470us**

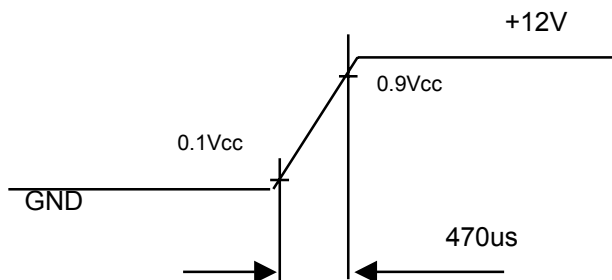



Note (3) The specified power supply current is under the conditions at  $V_{CC} = 12V$ ,  $T_a = 25 \pm 2^\circ C$ ,  $f_v = 60\text{ Hz}$ , whereas a power dissipation check pattern below is displayed.

a. White Pattern



Active Area

b. Black Pattern



Active Area

c. Vertical Stripe Pattern

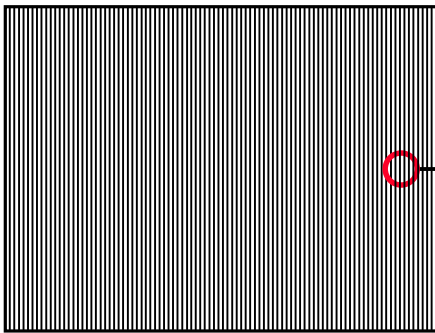

Active Area

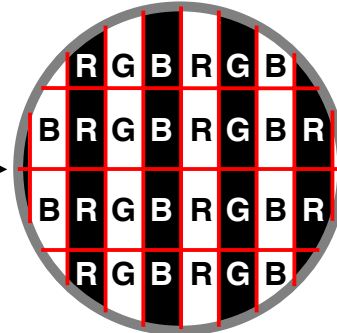

### 3.2 BACKLIGHT INVERTER UNIT

#### 3.2.1 CCFL (Cold Cathode Fluorescent Lamp) CHARACTERISTICS ( $T_a = 25 \pm 2^\circ C$ )

Parameter	Symbol	Value			Unit	Note
		Min.	Typ.	Max.		
Lamp Voltage	$V_W$	-	1290	-	$V_{RMS}$	$I_L = 4.2mA$
Lamp Current	$I_L$	3.7	4.2	4.7	$mA_{RMS}$	(1)
Lamp Starting Voltage	$V_S$	-	-	2450	$V_{RMS}$	(2), $T_a = 0^\circ C$
		-	-	2360	$V_{RMS}$	(2), $T_a = 25^\circ C$
Operating Frequency	$F_O$	40	-	70	KHZ	(3)
Lamp Life Time	$L_{BL}$	50,000		-	Hrs	(4)
	$L_{BLb}$	20,000				ADIM High (3.3V) 120%, Lamp current

**3.2.2 INVERTER CHARACTERISTICS** ( $T_a = 25 \pm 2 \text{ }^\circ\text{C}$ )

Parameter	Symbol	Value			Unit	Note
		Min.	Typ.	Max.		
Power Consumption	$P_{BL}$	-	96	108	W	(5),(6), $I_L = 4.2\text{mA}$
Input Voltage	$V_{BL}$	21.6	24	26.4	$V_{DC}$	
Input Current	$I_{BL}$	-	4.0	4.5	A	Non Dimming
Input Ripple	-	-	-	400	$\text{mV}_{p-p}$	$V_{BL} = 21.6\text{V}$
Input Noise	-	-	-	800	$\text{mV}_{p-p}$	$V_{BL} = 21.6\text{V}$
Backlight Turn on Voltage	$V_{BS}$	2450	-	-	$V_{RMS}$	$T_a = 0 \text{ }^\circ\text{C}$
		2360	-	-	$V_{RMS}$	$T_a = 25 \text{ }^\circ\text{C}$
Oscillating Frequency	$F_W$	55	58	61	kHz	
Dimming frequency	$F_B$	100	150	300	Hz	
Minimum Duty Ratio	$D_{MIN}$	(20)		(100)	%	
Input inrush current	-	-	-	5.5	Apeak	(7)

Note (1) Lamp current is measured by utilizing high frequency current meters as shown below:

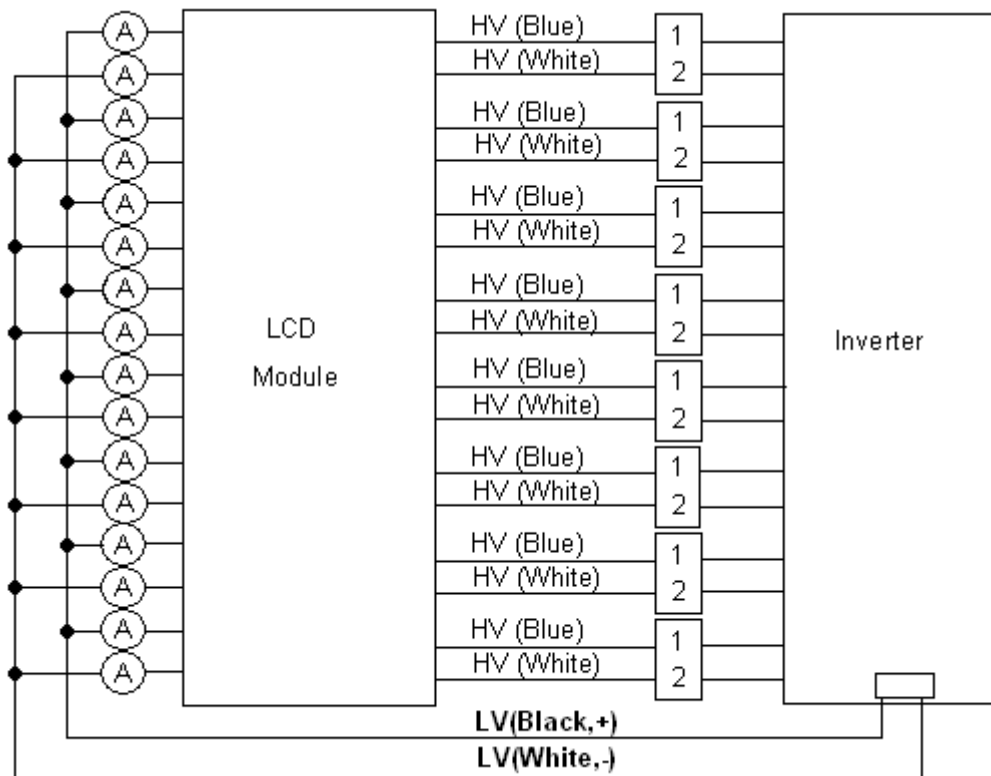

Note (2) The lamp starting voltage  $V_S$  should be applied to the lamp for more than 1 second under starting up duration. Otherwise the lamp could not be lighted on completed.

Note (3) The lamp frequency may produce interference with horizontal synchronous frequency of the display input signals, and it may result in line flow on the display. In order to avoid interference, the lamp frequency should be detached from the horizontal synchronous frequency and its harmonics as far as possible.

Note (4) The life time of a lamp is defined as when the brightness is larger than 50% of its original value and the effective discharge length is longer than 80% of its original length (Effective discharge length is defined as an area that has equal to or more than 70% brightness compared to the

brightness at the center point of lamp.) as the time in which it continues to operate under the condition at  $T_a = 25 \pm 2^\circ\text{C}$  and  $I_L = 3.7 \sim 4.7 \text{ mA}_{\text{RMS}}$ .

Note (5) The power supply capacity should be higher than the total inverter power consumption  $P_{\text{BL}}$ . Since the pulse width modulation (PWM) mode was applied for backlight dimming, the driving current changed as PWM duty on and off. The transient response of power supply should be considered for the changing loading when inverter dimming.

Note (6) The measurement condition of Max. value is based on 31.5" backlight unit under input voltage 24V, average lamp current 4.7 mA and lighting 30 minutes later.

Note (7) The measurement condition of input inrush current is based on 31.5" backlight unit. The rising time of power supply voltage must greater or equal to 20ms.

### 3.2.3 INVERTER INTERFACE CHARACTERISTICS

Parameter	Symbol	Test Condition	Value			Unit	Note	
			Min.	Typ.	Max.			
On/Off Control Voltage	ON	$V_{BLON}$	-	2.0	-	5.0	V	
	OFF		-	0	-	0.8	V	
ADIM	HI	$V_{ADIM}$	-	-	-	3.3	V	
	LO		-	-	0	-	V	
PDIM	High	$V_{PDIM}$	-	2.0	-	5.0	V	Logic High (open)
	Low		-	0	-	0.8	V	Logic Low

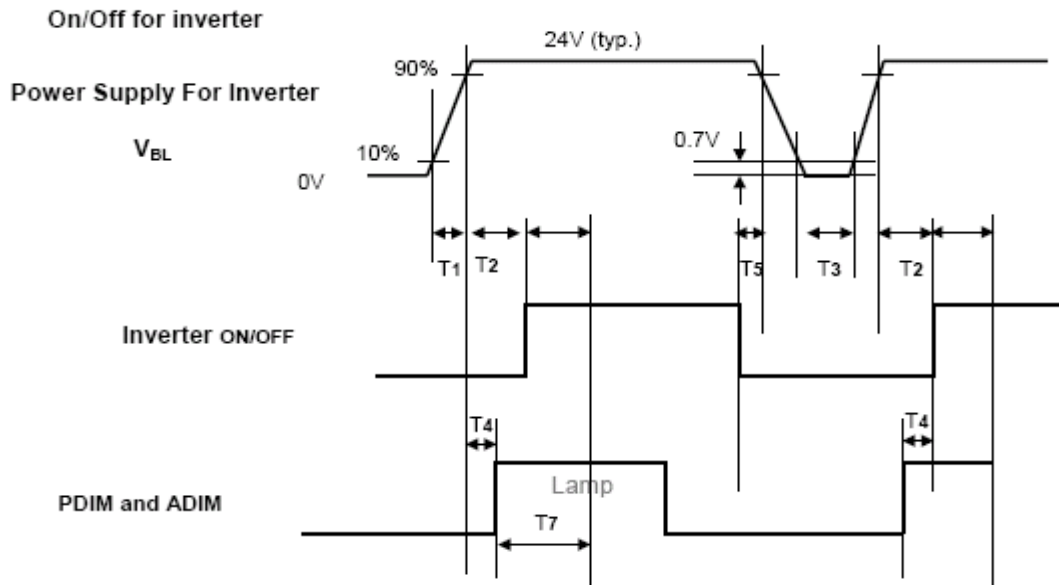

#### Deep condition for inverter

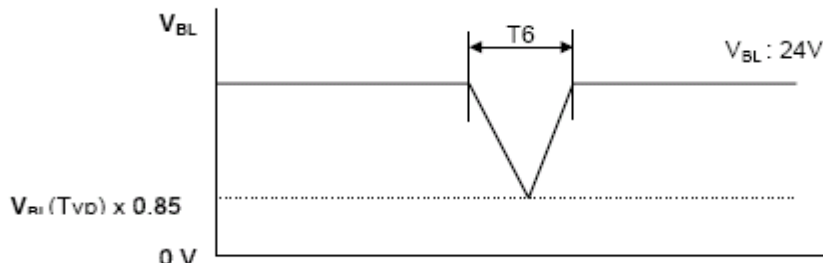

#### Power Sequence for Inverter

Parameter	Values			Units	Remarks
	Min	Typ	Max		
T1	20	-	-	ms	1
T2	500	-	-	ms	
T3	200	-	-	ms	
T4	0	-	-	ms	3
T5	10	-	-	ms	
T6	-	-	10	ms	$V_{RI}(TVD) \times 0.85$
T7	1000	-	-	ms	

Note : 1. T1 describes rising time of 0V to 24V and is not applied at restarting time.

2. When  $V_{BL}$  (24V) is supplied always, there is no reliability problem.

3. PDIM should be duty 100% in T4 section and ADIM recommend 1.65V.

(PDIM : PWM dimming, ADIM : Boost function control)

**INVERTER INTERFACE IMPEDANCE**

Pin No.	Symbol	Impedance
11	ADIM	172K±10%
12	ON/OFF	67K±10%
13	PDIM	51K±10%

## 4. BLOCK DIAGRAM

### 4.1 TFT LCD MODULE

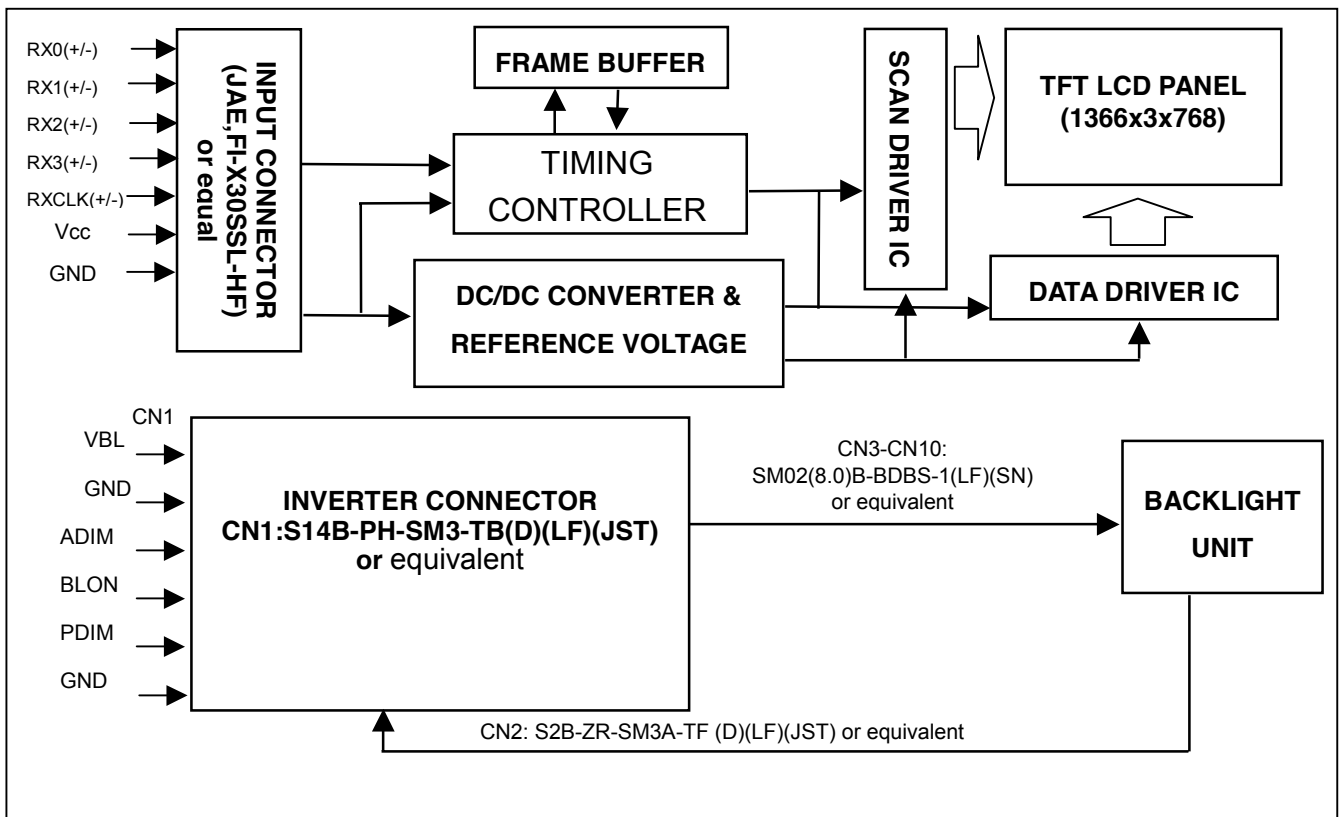

## 5. INTERFACE PIN CONNECTION

### 5.1 TFT LCD MODULE

#### CNF1 Connector Pin Assignment

Pin No.	Symbol	Description	Note
1	VCC	Power supply: +12V	
2	VCC	Power supply: +12V	
3	VCC	Power supply: +12V	
4	VCC	Power supply: +12V	
5	GND	Ground	
6	GND	Ground	
7	GND	Ground	
8	GND	Ground	
9	SELLVDS	Select LVDS data format	(2) (4)
10	NC	No connection	(3)
11	GND	Ground	
12	RX0-	Negative transmission data of pixel 0	
13	RX0+	Positive transmission data of pixel 0	
14	GND	Ground	
15	RX1-	Negative transmission data of pixel 1	
16	RX1+	Positive transmission data of pixel 1	
17	GND	Ground	
18	RX2-	Negative transmission data of pixel 2	
19	RX2+	Positive transmission data of pixel 2	
20	GND	Ground	
21	RXCLK-	Negative of clock	
22	RXCLK+	Positive of clock	
23	GND	Ground	
24	RX3-	Negative transmission data of pixel 3	
25	RX3+	Positive transmission data of pixel 3	
26	GND	Ground	
27	NC	No connection	(3)
28	NC	No connection	(3)
29	GND	Ground	
30	GND	Ground	

Note (1) Connector Part No.: FI-X30SSL-HF(JAE) or compatible

Note (2) Please refer to 5.5 LVDS INTERFACE (Page 19)

Note (3) Reserved for internal use. Left it open. If GND/High will cause panel abnormal display.

(but it will not cause panel damage)

Pin10 :reserve pin(no function)

Pin27 :Aging mode function(H :enable ,L :disable)

Pin28 :Flicker adjustment(H :enable ,L :disable)

Note (4) The impedance of option pin is 50K ohm

## 5.2 BACKLIGHT UNIT

The pin configuration for the housing and leader wire is shown in the table below.

CN3-CN10 (Housing): SM02(8.0)B-BDBS-1(LF)(SN) or equivalent

Pin No.	Symbol	Description	Wire Color
1	HV	High Voltage	Pink
2	HV	High Voltage	White

Note (1) The backlight interface housing for high voltage side is a model BHR-03VS-1, manufactured by JST or equivalent. The mating header on inverter part number is SM02(8.0)B-BHS-1-TB(LF).

CN2 (Housing): ZHR-2 (JST) or equivalent

Pin No.	Symbol	Description	Wire Color
1	LV	Low Voltage (+)	Black
2	LV	Low Voltage (-)	White

Note (2) The backlight interface housing and return cable for low voltage side is a model ZHR-2, manufactured by JST or equivalent. The mating header on inverter part number is S2B-ZR-SM3A-TF(D)(LF) or equivalent.

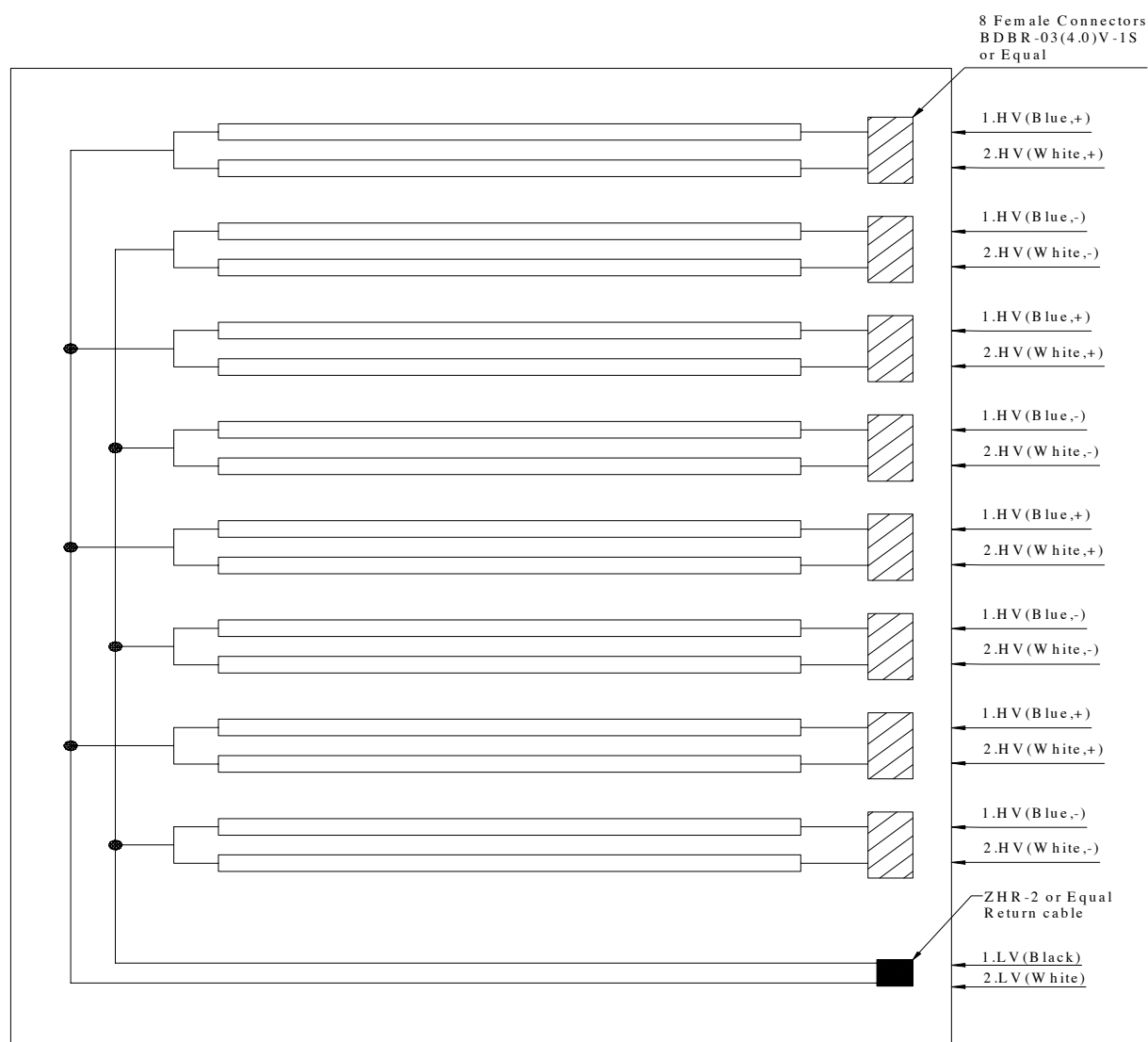



### 5.3 INVERTER UNIT

CN1(Header): S14B-PH-SM3-TB(D)(LF)(JST) or equivalent..

Pin No.	Symbol	Description
1	VBL	+24V Power input
2		
3		
4		
5		
6	GND	Ground
7		
8		
9		
10		
11	ADIM	GND (0V) 80% / Open (1.6V) 100% / High (3.3V) 120%, Lamp current
12	BLON	BL ON/OFF (ON is High/Open, OFF is Low, )
13	PDIM	PWM input signal, Open/High (3.3V, 100% Duty) for 100%
14	GND	GND

CN2(Header): S2B-ZR-SM3A-TF(D)(LF)(JST) or equivalent

Pin No.	Symbol	Description
1	CCFL COLD	CCFL low voltage (+)
2	CCFL COLD	CCFL low voltage (-)

CN3-CN8(Header): SM02(8.0)B-BDBS-1(LF)(SN) or equivalent.

Pin No.	Symbol	Description
1	CCFL HOT	CCFL high voltage
2	CCFL HOT	CCFL high voltage

### 5.4 BLOCK DIAGRAM OF INTERFACE

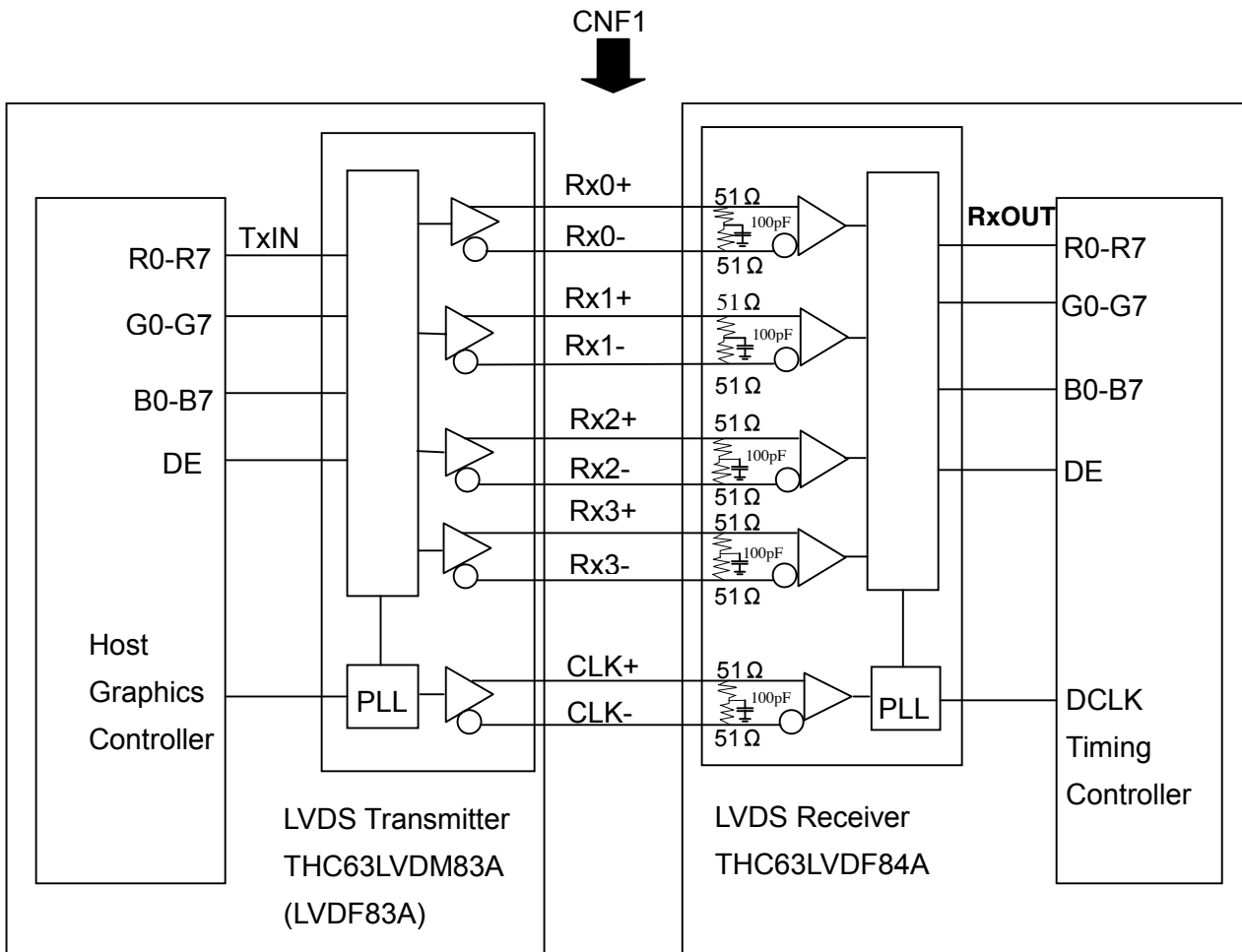

R0~R7 : Pixel R Data ,  
 G0~G7 : Pixel G Data ,  
 B0~B7 : Pixel B Data ,  
 DE : Data enable signal

Note (1) The system must have the transmitter to drive the module.

Note (2) LVDS cable impedance shall be 50 ohms per signal line or about 100 ohms per twist-pair line when it is used differentially.

### 5.5 LVDS INTERFACE

	SIGNAL		TRANSMITTER THC63LVDM83A		INTERFACE CONNECTOR		RECEIVER THC63LVDF84A		TFT CONTROL INPUT			
	SELLVDS =L or OPEN	SELLVDS =H	PIN	INPUT	Host	TFT-LCD	PIN	OUTPUT	SELLVDS =L or OPEN	SELLVDS =H		
24 bit	R0	R2	51	TxIN0	TA OUT0+	Rx 0+	27	Rx OUT0	R0	R2		
	R1	R3	52	TxIN1			29	Rx OUT1	R1	R3		
	R2	R4	54	TxIN2			30	Rx OUT2	R2	R4		
	R3	R5	55	TxIN3			32	Rx OUT3	R3	R5		
	R4	R6	56	TxIN4			33	Rx OUT4	R4	R6		
	R5	R7	3	TxIN6			TA OUT0-	Rx 0-	35	Rx OUT6	R5	R7
	G0	G2	4	TxIN7			37	Rx OUT7	G0	G2		
	G1	G3	6	TxIN8	38	Rx OUT8	G1	G3				
	G2	G4	7	TxIN9	39	Rx OUT9	G2	G4				
	G3	G5	11	TxIN12	TA OUT1+	Rx 1+	43	Rx OUT12	G3	G5		
	G4	G6	12	TxIN13	45	Rx OUT13	G4	G6				
	G5	G7	14	TxIN14	46	Rx OUT14	G5	G7				
	B0	B2	15	TxIN15	TA OUT1-	Rx 1-	47	Rx OUT15	B0	B2		
	B1	B3	19	TxIN18	51	Rx OUT18	B1	B3				
	B2	B4	20	TxIN19	53	Rx OUT19	B2	B4				
	B3	B5	22	TxIN20	54	Rx OUT20	B3	B5				
	B4	B6	23	TxIN21	TA OUT2+	Rx 2+	55	Rx OUT21	B4	B6		
	B5	B7	24	TxIN22	1	Rx OUT22	B5	B7				
	DE	DE	30	TxIN26	6	Rx OUT26	DE	DE				
	R6	R0	50	TxIN27	TA OUT2-	Rx 2-	7	Rx OUT27	R6	R0		
	R7	R1	2	TxIN5	34	Rx OUT5	R7	R1				
	G6	G0	8	TxIN10	41	Rx OUT10	G6	G0				
	G7	G1	10	TxIN11	42	Rx OUT11	G7	G1				
	B6	B0	16	TxIN16	TA OUT3+	Rx 3+	49	Rx OUT16	B6	B0		
	B7	B1	18	TxIN17	50	Rx OUT17	B7	B1				
RSVD 1	RSVD 1	25	TxIN23	2	Rx OUT23	NC	NC					
RSVD 2	RSVD 2	27	TxIN24	TA OUT3-	Rx 3-	3	Rx OUT24	NC	NC			
RSVD 3	RSVD 3	28	TxIN25	5	Rx OUT25	NC	NC					
DCLK			31	TxCLK IN	TxCLK OUT+	RxCLK IN+	26	RxCLK OUT	DCLK			
					TxCLK OUT-	RxCLK IN-						

R0~R7: Pixel R Data (7; MSB, 0; LSB)

G0~G7: Pixel G Data (7; MSB, 0; LSB)

B0~B7: Pixel B Data (7; MSB, 0; LSB)

DE: Data enable signal

Notes(1) RSVD(reserved)pins on the transmitter shall be "H" or ("L" or OPEN)

### 5.6 COLOR DATA INPUT ASSIGNMENT

The brightness of each primary color (red, green and blue) is based on the 8-bit gray scale data input for the color. The higher the binary input, the brighter the color. The table below provides the assignment of color versus data input.

Color		Data Signal																							
		Red								Green								Blue							
		R7	R6	R5	R4	R3	R2	R1	R0	G7	G6	G5	G4	G3	G2	G1	G0	B7	B6	B5	B4	B3	B2	B1	B0
Basic Colors	Black	0	0	0	0	0	0	0	0	0	0	0	0	0	0	0	0	0	0	0	0	0	0	0	
	Red	1	1	1	1	1	1	1	1	0	0	0	0	0	0	0	0	0	0	0	0	0	0	0	
	Green	0	0	0	0	0	0	0	0	1	1	1	1	1	1	1	1	0	0	0	0	0	0	0	
	Blue	0	0	0	0	0	0	0	0	0	0	0	0	0	0	0	1	1	1	1	1	1	1	1	
	Cyan	0	0	0	0	0	0	0	0	1	1	1	1	1	1	1	1	1	1	1	1	1	1	1	
	Magenta	1	1	1	1	1	1	1	1	0	0	0	0	0	0	0	1	1	1	1	1	1	1	1	
	Yellow	1	1	1	1	1	1	1	1	1	1	1	1	1	1	1	0	0	0	0	0	0	0	0	
	White	1	1	1	1	1	1	1	1	1	1	1	1	1	1	1	1	1	1	1	1	1	1	1	
Gray Scale Of Red	Red(0) / Dark	0	0	0	0	0	0	0	0	0	0	0	0	0	0	0	0	0	0	0	0	0	0		
	Red(1)	0	0	0	0	0	0	1	0	0	0	0	0	0	0	0	0	0	0	0	0	0	0		
	Red(2)	0	0	0	0	0	1	0	0	0	0	0	0	0	0	0	0	0	0	0	0	0	0		
	:	:	:	:	:	:	:	:	:	:	:	:	:	:	:	:	:	:	:	:	:	:	:		
	:	:	:	:	:	:	:	:	:	:	:	:	:	:	:	:	:	:	:	:	:	:	:		
	Red(253)	1	1	1	1	1	1	0	1	0	0	0	0	0	0	0	0	0	0	0	0	0	0		
	Red(254)	1	1	1	1	1	1	1	0	0	0	0	0	0	0	0	0	0	0	0	0	0	0		
	Red(255)	1	1	1	1	1	1	1	1	0	0	0	0	0	0	0	0	0	0	0	0	0	0		
Gray Scale Of Green	Green(0) / Dark	0	0	0	0	0	0	0	0	0	0	0	0	0	0	0	0	0	0	0	0	0	0		
	Green(1)	0	0	0	0	0	0	0	0	0	0	0	0	0	1	0	0	0	0	0	0	0	0		
	Green(2)	0	0	0	0	0	0	0	0	0	0	0	0	1	0	0	0	0	0	0	0	0	0		
	:	:	:	:	:	:	:	:	:	:	:	:	:	:	:	:	:	:	:	:	:	:	:		
	:	:	:	:	:	:	:	:	:	:	:	:	:	:	:	:	:	:	:	:	:	:	:		
	Green(253)	0	0	0	0	0	0	0	1	1	1	1	1	1	0	1	0	0	0	0	0	0	0		
	Green(254)	0	0	0	0	0	0	0	1	1	1	1	1	1	1	0	0	0	0	0	0	0	0		
	Green(255)	0	0	0	0	0	0	0	1	1	1	1	1	1	1	1	0	0	0	0	0	0	0		
Gray Scale Of Blue	Blue(0) / Dark	0	0	0	0	0	0	0	0	0	0	0	0	0	0	0	0	0	0	0	0	0	0		
	Blue(1)	0	0	0	0	0	0	0	0	0	0	0	0	0	0	0	0	0	0	0	0	0	1		
	Blue(2)	0	0	0	0	0	0	0	0	0	0	0	0	0	0	0	0	0	0	0	0	1	0		
	:	:	:	:	:	:	:	:	:	:	:	:	:	:	:	:	:	:	:	:	:	:	:		
	:	:	:	:	:	:	:	:	:	:	:	:	:	:	:	:	:	:	:	:	:	:	:		
	Blue(253)	0	0	0	0	0	0	0	0	0	0	0	0	0	0	1	1	1	1	1	1	1	0		
	Blue(254)	0	0	0	0	0	0	0	0	0	0	0	0	0	0	1	1	1	1	1	1	1	0		
	Blue(255)	0	0	0	0	0	0	0	0	0	0	0	0	0	0	1	1	1	1	1	1	1	1		

Note (1) 0: Low Level Voltage, 1: High Level Voltage

## 6. INTERFACE TIMING

### 6.1 INPUT SIGNAL TIMING SPECIFICATIONS

The input signal timing specifications are shown as the following table and timing diagram.

Signal	Item	Symbol	Min.	Typ.	Max.	Unit	Note
LVDS Receiver Clock	Frequency	1/Tc	51.86	74.5	82	MHZ	
	Input cycle to cycle jitter	Trcl	-	-	200	ps	
LVDS Receiver Data	Setup Time	Tlvsu	600	-	-	ps	
	Hold Time	Tlvhd	600	-	-	ps	
Vertical Active Display Term	Frame Rate	Fr5	47	50	53	Hz	(2)
		-	57	60	63	Hz	
	Total	Tv	776	806	1000	Th	Tv=Tvd+Tvb
	Display	Tvd	768	768	768	Th	-
	Blank	Tvb	8	38	-	Th	-
Horizontal Active Display Term	Total	Th	1442	1560	2000	Tc	Th=Thd+Thb
	Display	Thd	1366	1366	1366	Tc	-
	Blank	Thb	76	194	-	Tc	-

Note (1) Since this module is operated in DE only mode, Hsync and Vsync input signals should be set to low logic level. Otherwise, this module would operate abnormally.

(2) Please refer to 5.1 for detail information.

### INPUT SIGNAL TIMING DIAGRAM

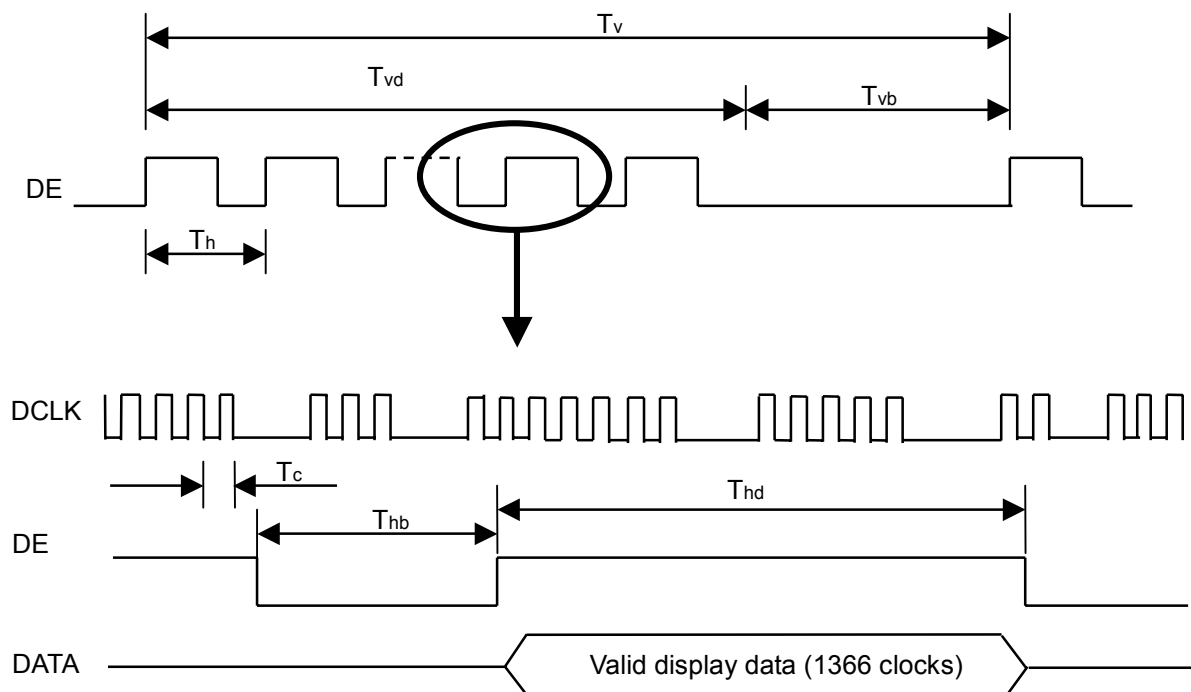

**LVDS RECEIVER INTERFACE TIMING DIAGRAM**

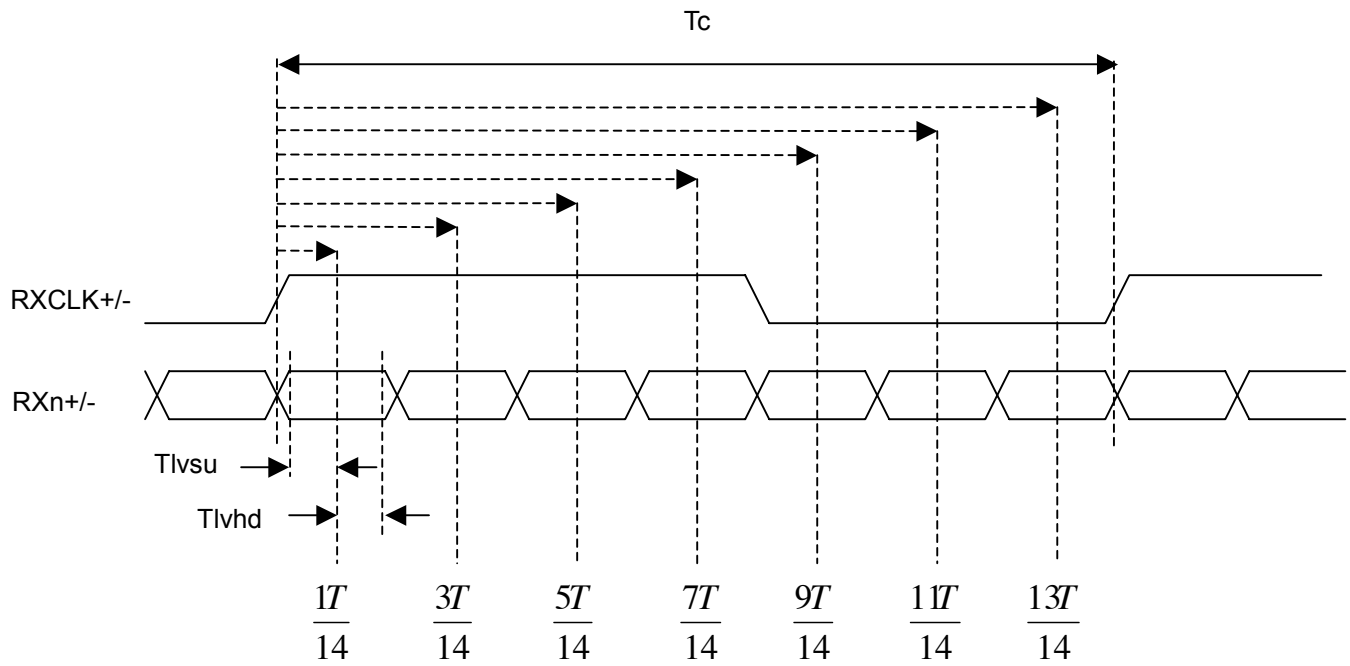

## 6.2 POWER ON/OFF SEQUENCE

To prevent a latch-up or DC operation of LCD module, the power on/off sequence should be as the diagram below.

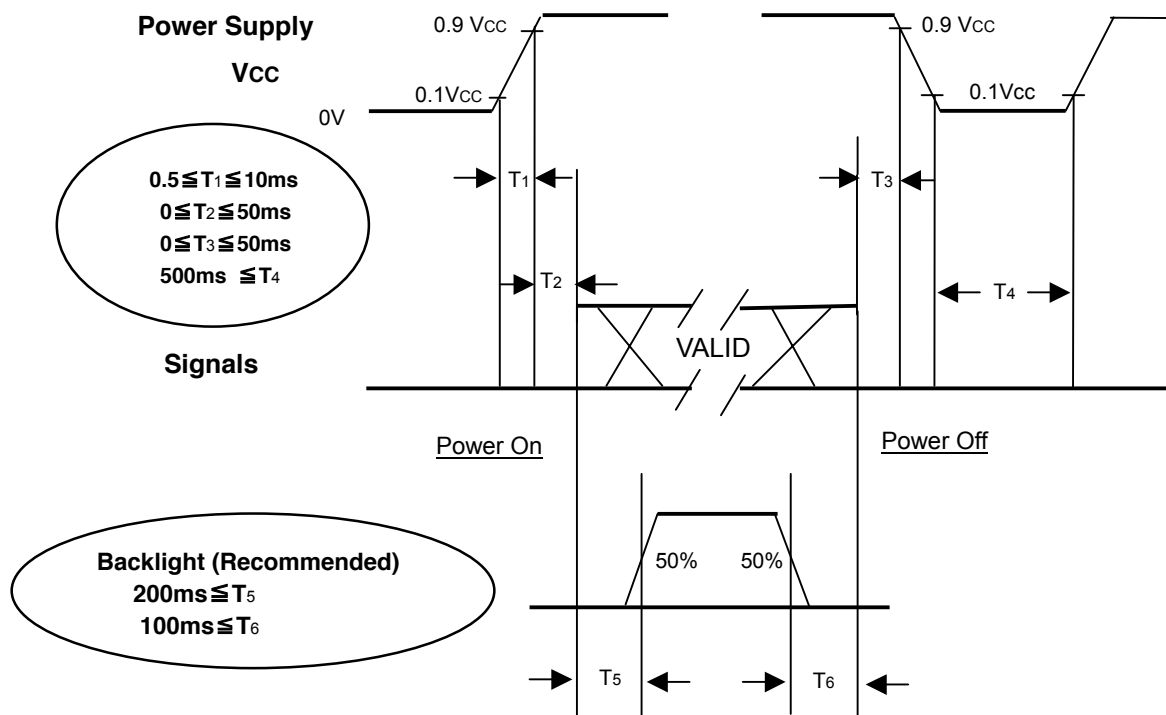

**Power ON/OFF Sequence**

Note (1) The supply voltage of the external system for the module input should follow the definition of Vcc.

Note (2) Apply the lamp voltage within the LCD operation range. When the backlight turns on before the LCD operation or the LCD turns off before the backlight turns off, the display may momentarily become abnormal screen.

Note (3) In case of Vcc is in off level, please keep the level of input signals on the low or high impedance.

Note (4) T4 should be measured after the module has been fully discharged between power off and on period.

Note (5) Interface signal shall not be kept at high impedance when the power is on.

## 7. OPTICAL CHARACTERISTICS

### 7.1 TEST CONDITIONS

Item	Symbol	Value	Unit
Ambient Temperature	Ta	25±2	°C
Ambient Humidity	Ha	50±10	%RH
Supply Voltage	V <sub>CC</sub>	12.0	V
Input Signal	According to typical value in "3. ELECTRICAL CHARACTERISTICS"		
Lamp Current	I <sub>L</sub>	4.2mA ± 0.5	mA
Oscillating Frequency (Inverter)	F <sub>W</sub>	58±3	KHz
Frame rate		60	Hz

### 7.2 OPTICAL SPECIFICATIONS

The relative measurement methods of optical characteristics are shown in 7.2. The following items should be measured under the test conditions described in 7.1 and stable environment shown in Note (6).

tem	Symbol	Condition	Min.	Typ.	Max.	Unit	Note	
Contrast Ratio	CR	$\theta_x=0^\circ, \theta_y=0^\circ$ Viewing angle at normal direction	1200	1500	-	-	(2)	
Response Time (Frame rate:50Hz)	TR				18	23		(3)
	TF				6	11		(3)
	Gray to gray			-	8.5	12	ms	(4)
Center Luminance of White	L <sub>C</sub>			400	500	-	cd/m <sup>2</sup>	(5)
Average Luminance of White	L <sub>Ave(5points)</sub>			400	450	-	cd/m <sup>2</sup>	
White Variation	δW			-	-	1.3		100% dimming duty (8)
						1.5		30% dimming duty (8)
Cross Talk	CT			-	-	4.0	%	(6)
Color Chromaticity	Red		Rx	Typ-0.03	0.643	Typ+0.03	-	(7)
			Ry		0.333		-	
	Green		Gx		0.272		-	
			Gy		0.595		-	
	Blue	Bx	0.144		-			
		By	0.069		-			
	White	Wx	0.285		-			
		Wy	0.293		-			
Color	CG	70	72		%	NTSC		
Viewing Angle	Horizontal	θ <sub>x+</sub>	80	88	-	Deg.	(1)	
		θ <sub>x-</sub>	80	88	-			
	Vertical	θ <sub>y+</sub>	80	88	-			
		θ <sub>y-</sub>	80	88	-			



Note (1) Definition of Viewing Angle ( $\theta_x, \theta_y$ ):

Viewing angles are measured by EZ-Contrast 160R (Eldim)

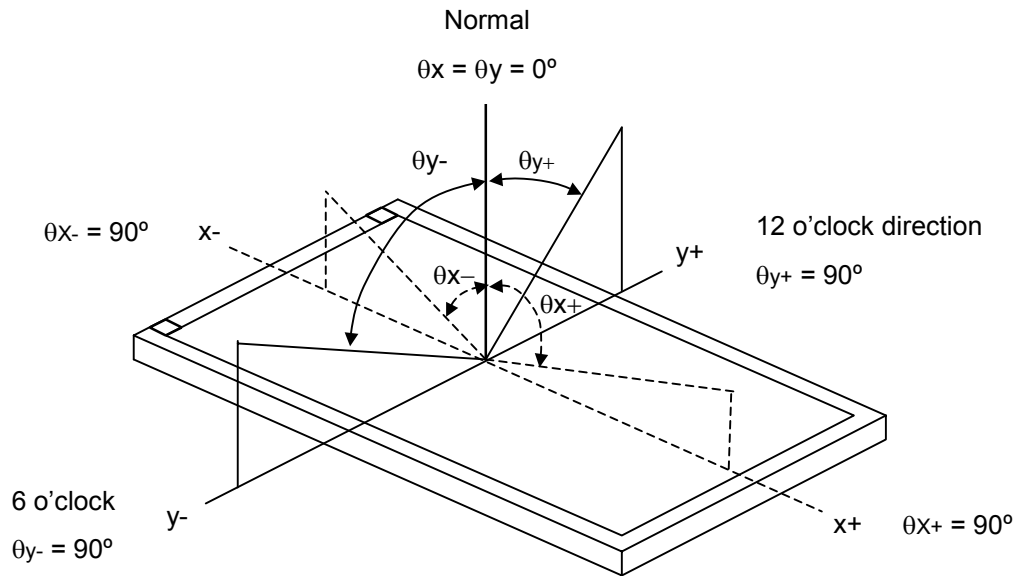

Note (2) Definition of Contrast Ratio (CR):

The contrast ratio can be calculated by the following expression.

$$\text{Contrast Ratio (CR)} = L_{255} / L_0$$

L<sub>255</sub>: Luminance of gray level 255

L<sub>0</sub>: Luminance of gray level 0

CR = CR (X), where CR (X) is corresponding to the Contrast Ratio of the point X at the figure in Note (7).

Note (3) Definition of Response Time (TR, TF):

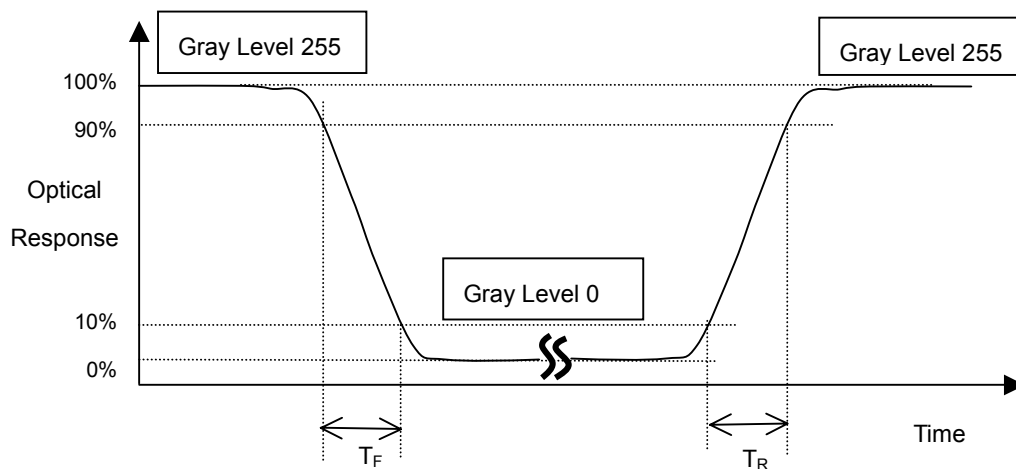

Note (4) Definition of Gray to Gray Switching Time :

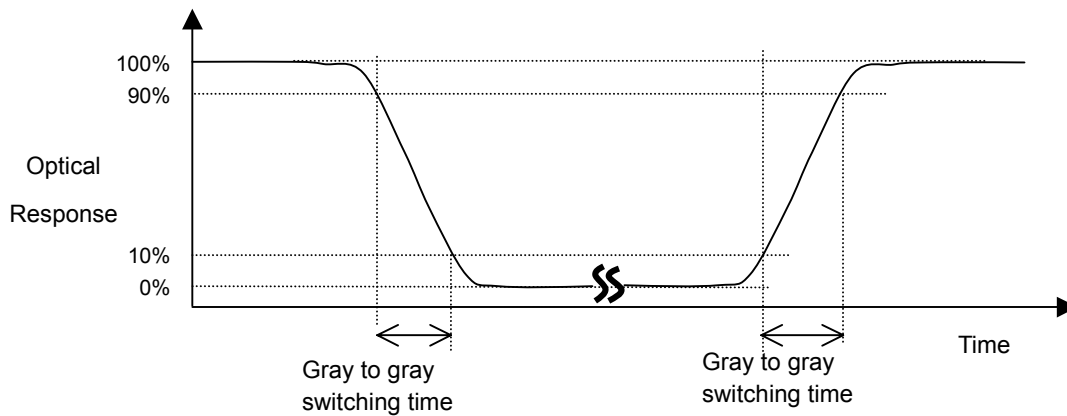

The driving signal means the signal of gray level 0, 63, 127, 191, 255.

Gray to gray average time means the average switching time of gray level 0, 63, 127, 191, 255 to each other .

Note (5) Definition of Luminance of White ( $L_C$ ,  $L_{AVE}$ ):

Measure the luminance of gray level 255 at center point and 5 points

$$L_C = L (5)$$

$$L_{AVE} = [L (1)+ L (2)+ L (3)+ L (4)+ L (5)] / 5$$

where L (x) is corresponding to the luminance of the point X at the figure in Note (7).

Note (6) Definition of Cross Talk (CT):

$$CT = | Y_B - Y_A | / Y_A \times 100 (\%)$$

Where:

$Y_A$  = Luminance of measured location without gray level 0 pattern ( $cd/m^2$ )

$Y_B$  = Luminance of measured location with gray level 0 pattern ( $cd/m^2$ )

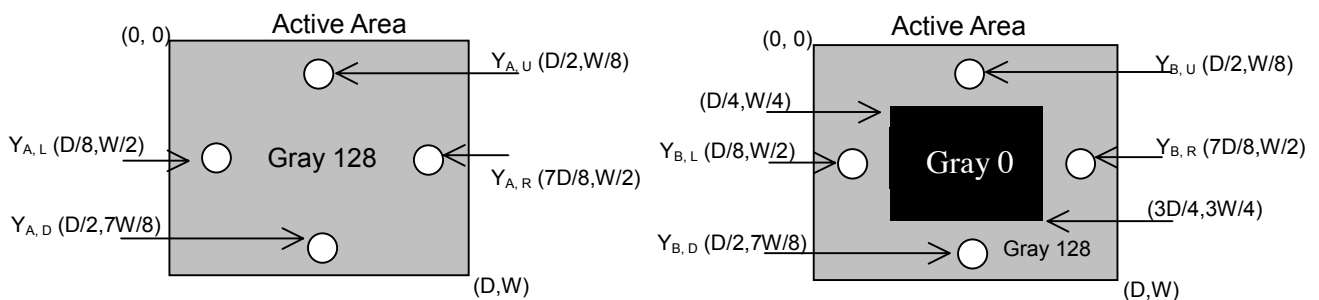

**Note (7) Measurement Setup:**

The LCD module should be stabilized at given temperature for 1 hour to avoid abrupt temperature change during measuring. In order to stabilize the luminance, the measurement should be executed after lighting Backlight for 1 hour in a windless room.

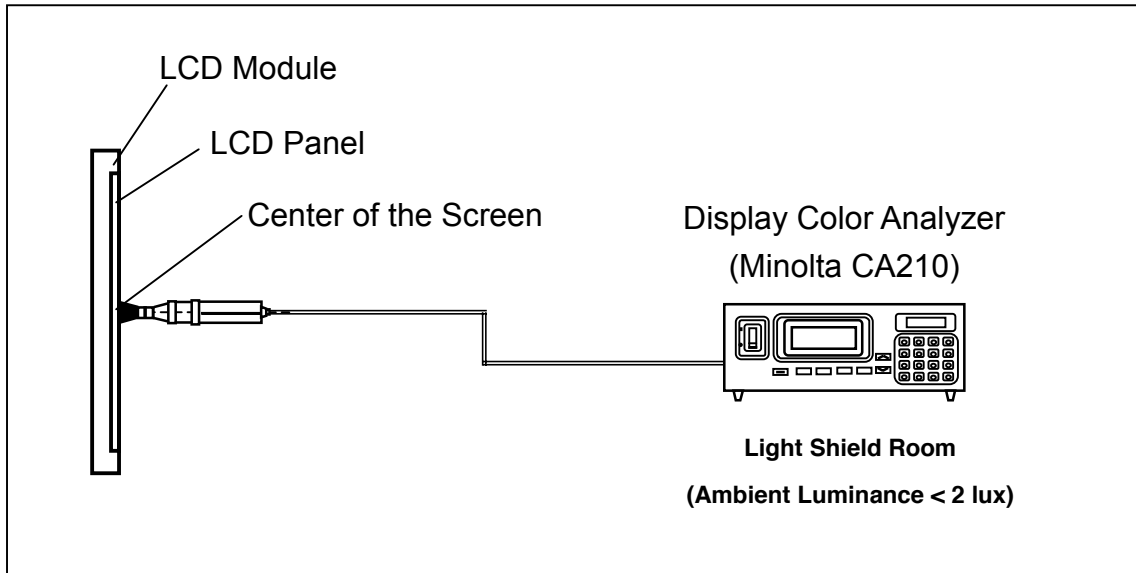
**Note (8) Definition of White Variation ( $\delta W$ ):**

PWM input signal for dimming duty refer to **3.2.2 INVERTER CHARACTERISTICS**.

Measure the luminance of gray level 255 at 5 points

$$\delta W = \text{Maximum} [L (1), L (2), L (3), L (4), L (5)] / \text{Minimum} [L (1), L (2), L (3), L (4), L (5)]$$

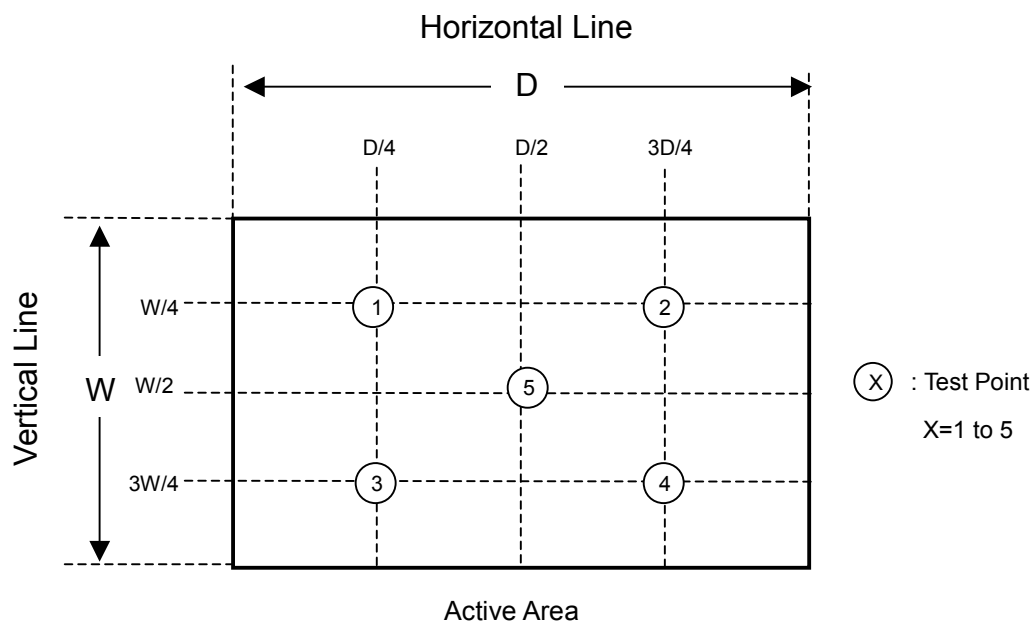

## 8. DEFINITION OF LABELS

### 8.1 CMO MODULE LABEL

The barcode nameplate is pasted on each module as illustration, and its definitions are as following explanation.

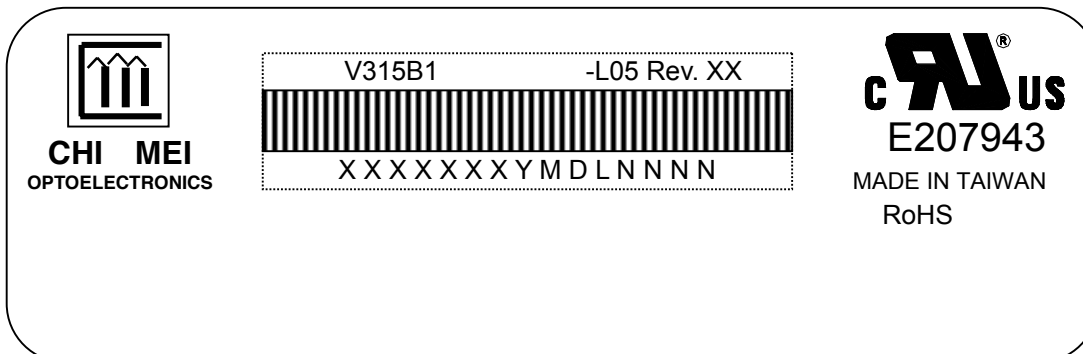

- (a) Model Name: V315B1-L05
- (b) Revision: Rev. XX, for example: A0, A1... B1, B2... or C1, C2...etc.
- (c) Serial ID: X X X X X X Y M D L N N N N

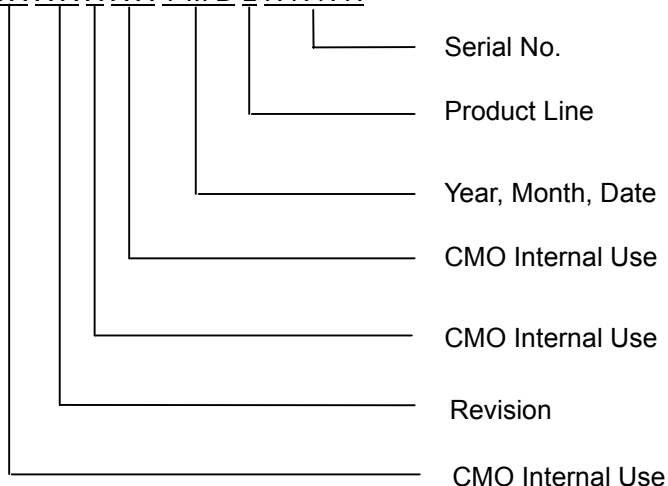

Serial ID includes the information as below:

- (a) Manufactured Date: Year: 0~9, for 2000~2009  
 Month: 1~9, A~C, for Jan. ~ Dec.  
 Day: 1~9, A~Y, for 1<sup>st</sup> to 31<sup>st</sup>, exclude I ,O, and U.
- (b) Revision Code: Cover all the change
- (c) Serial No.: Manufacturing sequence of product
- (d) Product Line: 1 -> Line1, 2 -> Line 2, ...etc.

## 9. PACKAGING

### 9.1 PACKING SPECIFICATIONS

- (1) 4 LCD TV modules / 1 Box
- (2) Box dimensions : 906(L) X 384 (W) X 580 (H)
- (3) Weight : approximately 31.5Kg ( 4 modules per box)

### 9.2 PACKING METHOD

Figures 9-1 and 9-2 are the packing method

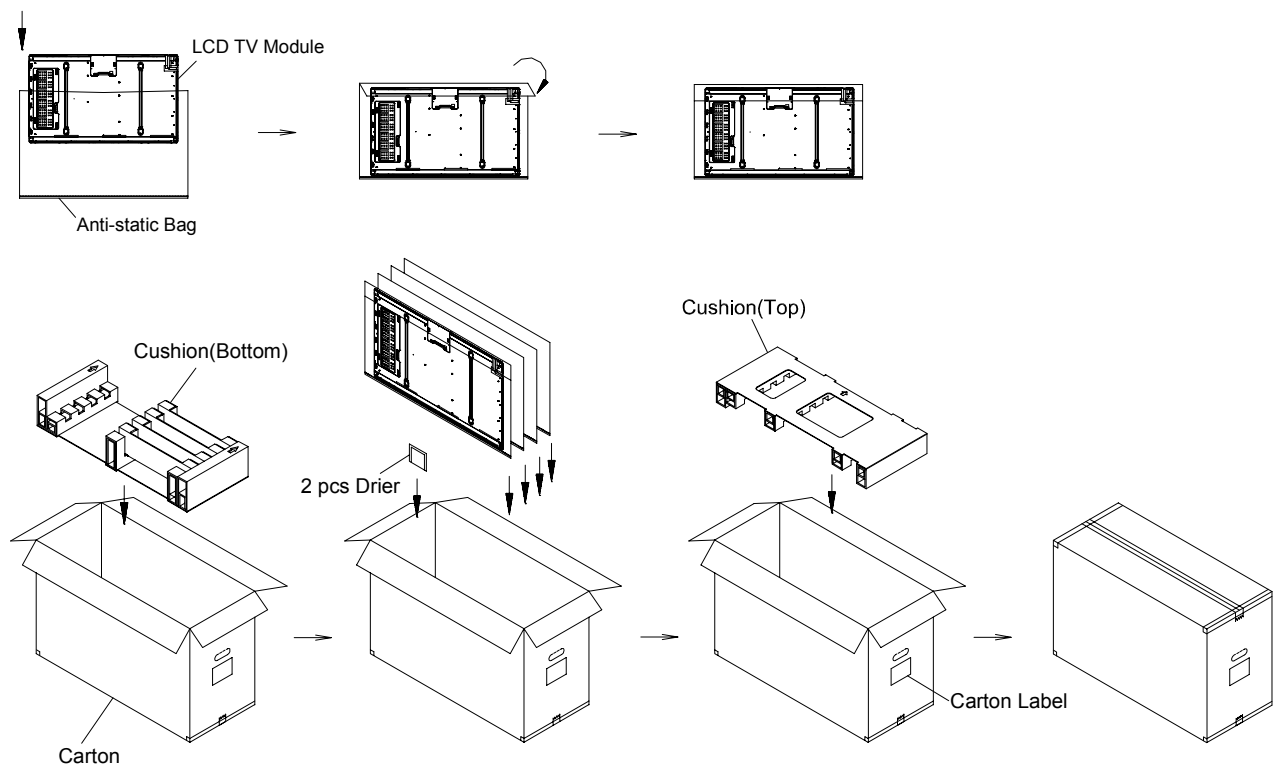
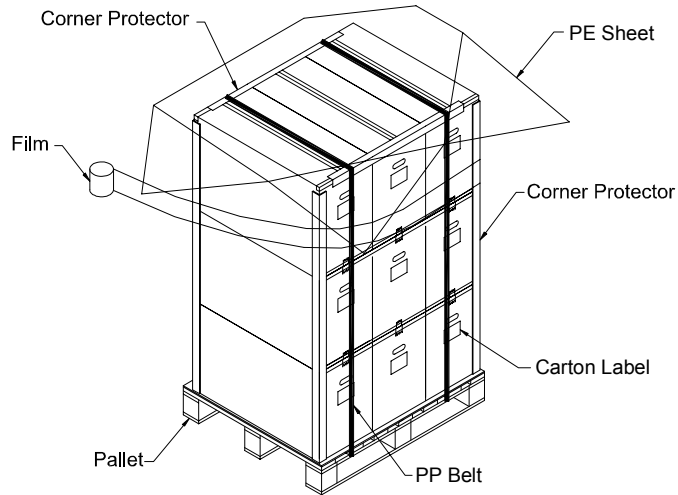

Figure.9-1 packing method

### Sea Transportation

Corner Protector:L1130\*50mm\*50mm  
 Corner Protector:L1400\*50mm\*50mm  
 Pallet:L950\*W1180\*H140mm  
 Pallet Stack:L950\*W1180\*H1880mm  
 Gross:300kg



### Air Transportation

Corner Protector:L1130\*50mm\*50mm  
 Pallet:L950\*W1180\*H140mm  
 Pallet Stack:L950\*W1180\*H1300mm  
 Gross:205kg

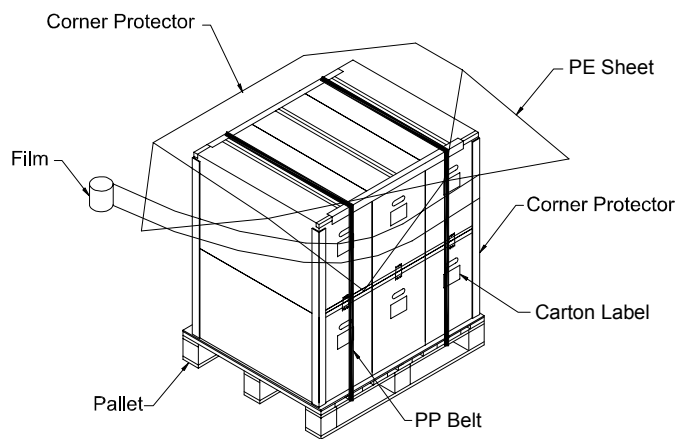

Figure. 9-2 Packing method

## 10. PRECAUTIONS

### 10.1 ASSEMBLY AND HANDLING PRECAUTIONS

- (1) Do not apply rough force such as bending or twisting to the module during assembly.
- (2) It is recommended to assemble or to install a module into the user's system in clean working areas.  
The dust and oil may cause electrical short or worsen the polarizer.
- (3) Do not apply pressure or impulse to the module to prevent the damage of LCD panel and backlight.
- (4) Always follow the correct power-on sequence when the LCD module is turned on. This can prevent the damage and latch-up of the CMOS LSI chips.
- (5) Do not plug in or pull out the I/F connector while the module is in operation.
- (6) Do not disassemble the module.
- (7) Use a soft dry cloth without chemicals for cleaning, because the surface of polarizer is very soft and easily scratched.
- (8) Moisture can easily penetrate into LCD module and may cause the damage during operation.
- (9) High temperature or humidity may deteriorate the performance of LCD module. Please store LCD modules in the specified storage conditions.
- (10) When ambient temperature is lower than 10°C, the display quality might be reduced. For example, the response time will become slow, and the starting voltage of CCFL will be higher than that of room temperature.

### 10.2 SAFETY PRECAUTIONS

- (1) The startup voltage of a backlight is over 1000 Volts. It may cause an electrical shock while assembling with the inverter. Do not disassemble the module or insert anything into the backlight unit.
- (2) If the liquid crystal material leaks from the panel, it should be kept away from the eyes or mouth. In case of contact with hands, skin or clothes, it has to be washed away thoroughly with soap.
- (3) After the module's end of life, it is not harmful in case of normal operation and storage.

## 11. REGULATORY STANDARDS

### 11.1 SAFETY

Item	Standard
UL	UL 60950-1: 2003
UL	UL 60065: 2003
cUL	CAN/CSA C22.2 No.60950-1-03
cUL	CAN/CSA C22.2 No.60065-03
CB	IEC 60950-1:2001
CB	IEC 60065:2001

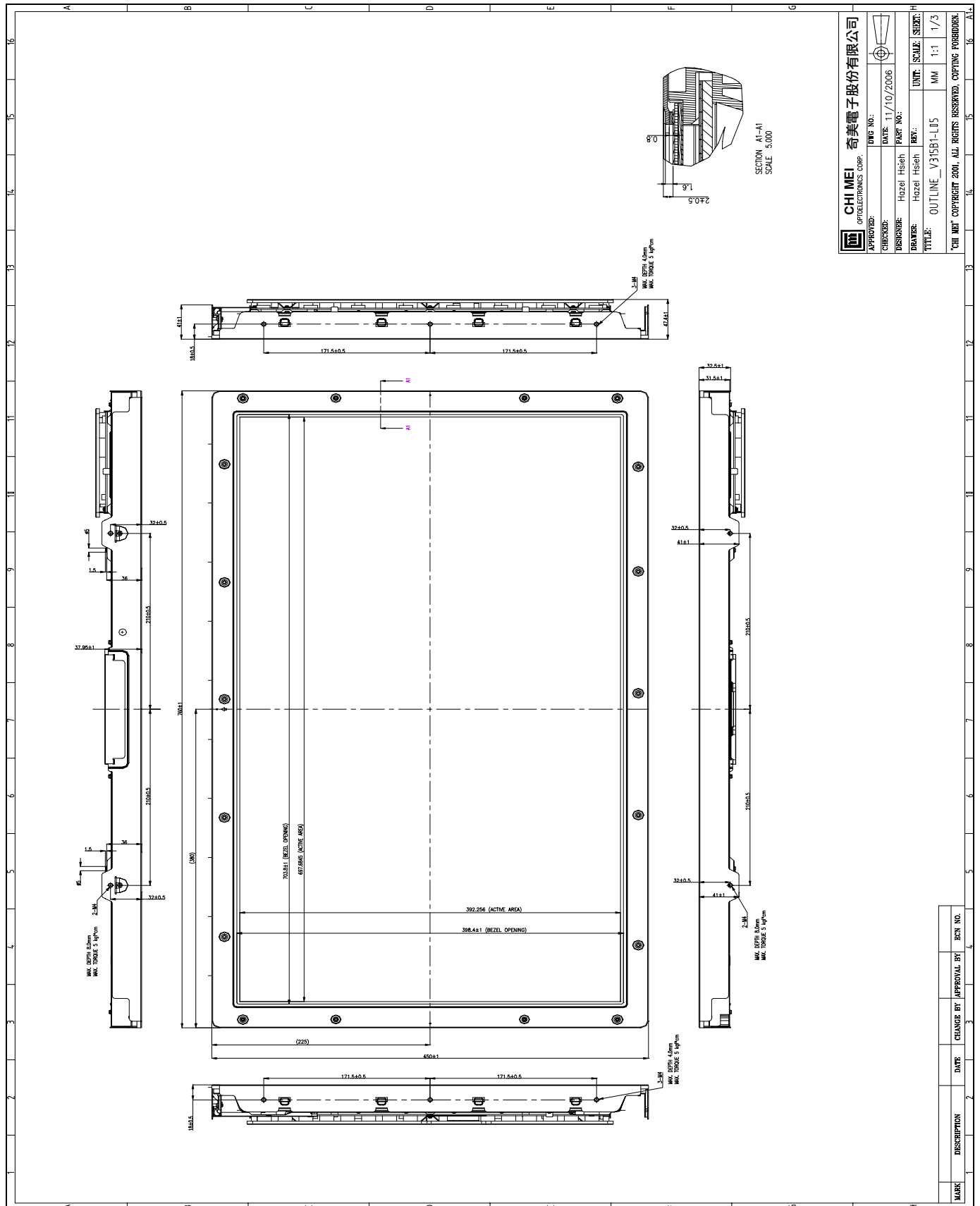
**12. MECHANICAL CHARACTERISTICS**

<b>CHI MEI</b> 奇美電子股份有限公司 OPTOELECTRONICS CORP.	
APPROVED:	DATE: 11/10/2006
CHECKED: Hazel Hsieh	PART No.:
DESIGNED: Hazel Hsieh	BY: Hazel Hsieh
DRAWN: OUTLINE_V315B1-L05	UNIT: MM
TITLE: OUTLINE_V315B1-L05	SCALE: 1:1
SHEET: 1/3	
"CHI MEI" COPYRIGHT 2001. ALL RIGHTS RESERVED. COPYING FORBIDDEN.	

MARK	DESCRIPTION	DATE	CHANGE BY	APPROVAL BY	ECN NO.



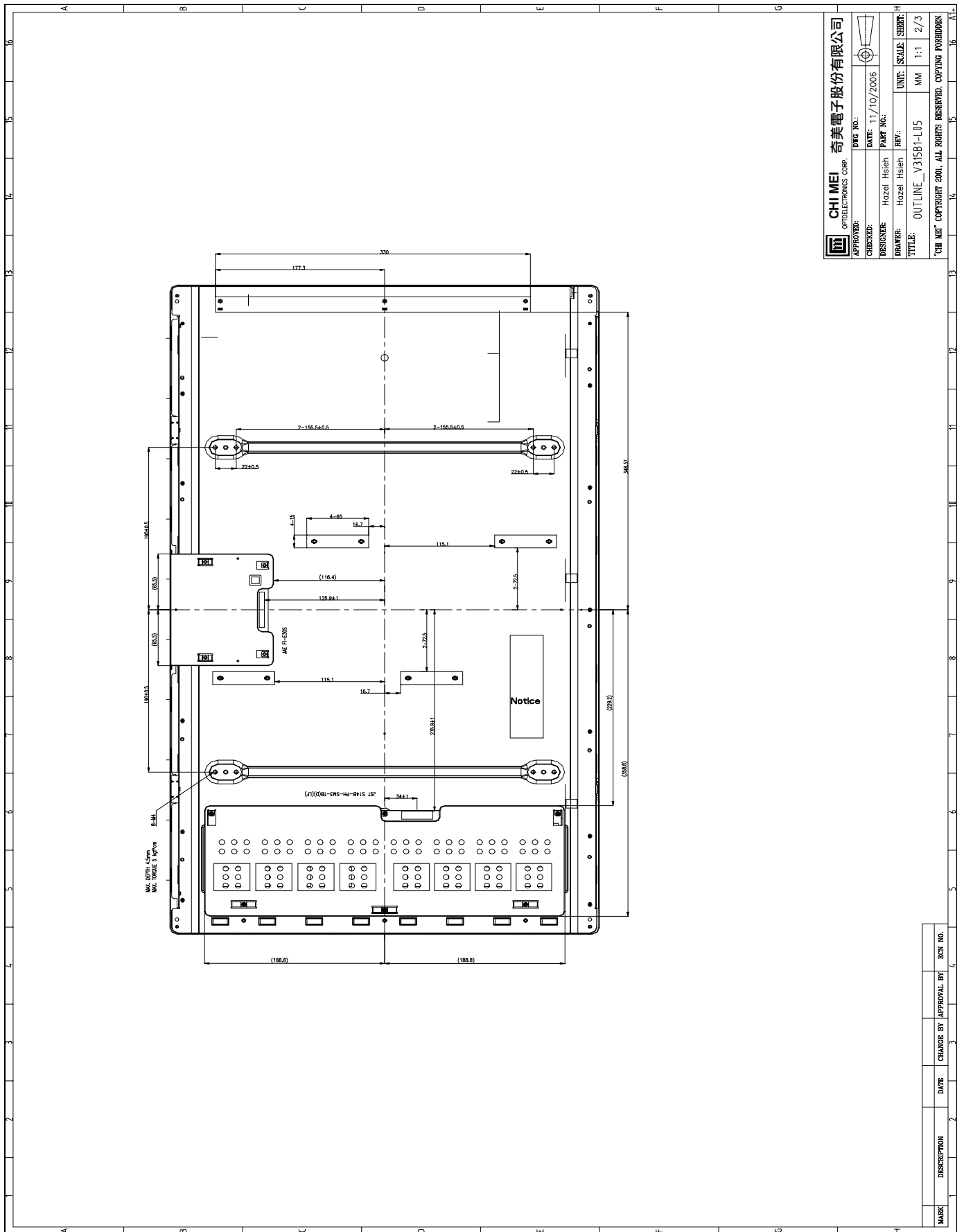

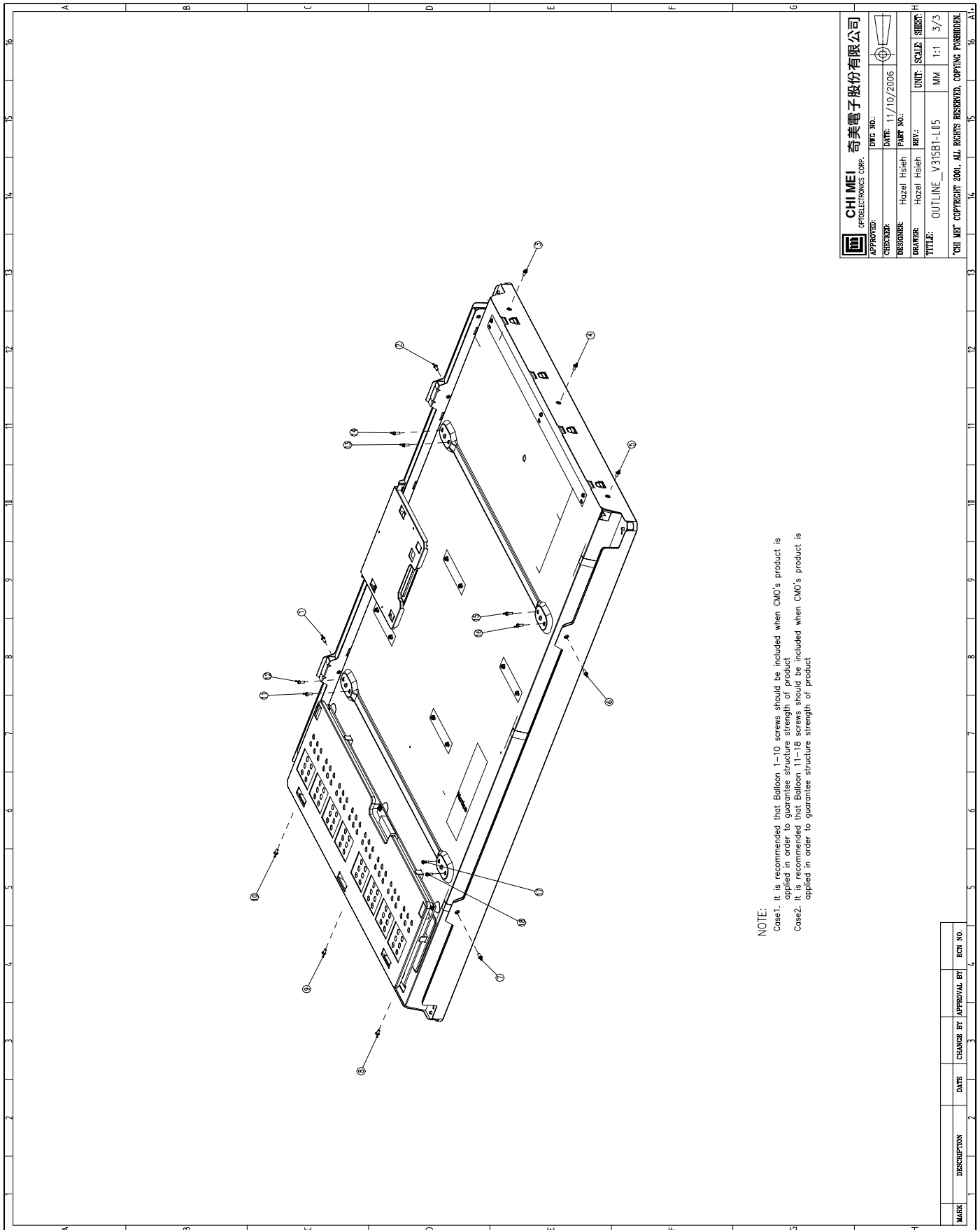

NOTE:  
Case1: It is recommended that Balloon 1-10 screws should be included when CMO's product is applied in our product structure strength of product.  
Case2: It is recommended that Balloon 11-18 screws should be included when CMO's product is applied in order to guarantee structure strength of product.

<b>CHI MEI</b> OPTOELECTRONICS CORP.		<b>奇美電子股份有限公司</b>	
APPROVED:	DWG. NO.:	DATE:	11/10/2006
CHECKED:	DESIGNER:	HAZEL HSEH	PAPER NO.:
DRAWER:	REVISION:	HAZEL HSEH	UNIT: SCALE: SUBPT:
TITLE: OUTLINE_V315B1-L05		MM	1:1
		3/3	
"CHI MEI" COPYRIGHT 2001. ALL RIGHTS RESERVED. COPYING FORBIDDEN.			

MARK	DESCRIPTION	DATE	CHANGE BY	APPROVAL BY	ECN NO.

**13. Appendix :**

## ACOUSTICAL NOISE REQUIREMENT

Measurement of all residual noises (e.g. back light, inverter, fans ...) will be done in a silent reverberant room. If available, the electronic box is placed under the LCD. Measure the sound level frequency dependant on 8 points around the LCD. The position in height of the sound audiometer is the middle of the LCD. Measure this on frequency span 100 Hz -20 kHz (gives an overview of the total spectrum) and measure this on frequency span 100 Hz - 1500 Hz.

Performance parameter	Class	LCD size	Requirement
General audible noise. Sound level.	ALL	ALL	<b>&lt; 20 dBA</b>

$$\text{Sound level} = \frac{\Sigma \text{ sound level from A to H}}{8} \text{ (dBA)}$$

