

TFT LCD Tentative Specification

MODEL NO.: V315B1- LE 7

Customer: _____
Approved by: _____
Note:

Approved By	TV Product Marketing & Management Div	
	Chao-Chun Chung	

Reviewed By	QA Dept.	Product Development Div.
	Hsin-nan Chen	WT Lin

Prepared By	LCD TV Marketing and Product Management Div.	
	CY Chang	Lee Lee Chang

CONTENTS -

1. GENERAL DESCRIPTION.....	5
1.1 OVERVIEW	5
1.2 FEATURES	5
1.3 APPLICATION	5
1.4 GENERAL SPECIFICATIONS	5
1.5 MECHANICAL SPECIFICATIONS	5
2. ABSOLUTE MAXIMUM RATINGS.....	6
2.1 ABSOLUTE RATINGS OF ENVIRONMENT	6
2.2 PACKAGE STORGE.....	7
2.3 ELECTRICAL ABSOLUTE RATINGS.....	7
3. ELECTRICAL CHARACTERISTICS.....	8
3.1 TFT LCD MODULE.....	8
3.2 BACKLIGHT UNIT	10
4. BLOCK DIAGRAM OF INTERFACE.....	11
4.1 TFT LCD MODULE.....	11
5. INTERFACE PIN CONNECTION	12
5.1 TFT LCD MODULE.....	12
5.2 BACKLIGHT UNIT.....	15
5.3 CONVERTER UNIT.....	15
5.4 BLOCK DIAGRAM OF INTERFACE	17
5.5 LVDS INTERFACE	19
5.6 COLOR DATA INPUT ASSIGNMENT.....	20
6. INTERFACE TIMING	21
6.1 INPUT SIGNAL TIMING SPECIFICATIONS.....	21
6.2 POWER ON/OFF SEQUENCE	24
7. OPTICAL CHARACTERISTICS	25
7.1 TEST CONDITIONS.....	25
7.2 OPTICAL SPECIFICATIONS	25
8. DEFINITION OF LABELS	29
8.1 CMO MODULE LABEL.....	29
9. PACKAGING.....	30
9.1 PACKING SPECIFICATIONS.....	30
9.2 PACKING METHOD	30
10. PRECAUTIONS.....	32
10.1 ASSEMBLY AND HANDLING PRECAUTIONS	32
10.2 SAFETY PRECAUTIONS	32
10.3 STORAGE PRECAUTIONS.....	32



Issued Date: 27, Jan 2010

Model No.: V315B1-LE7

Tentative

11. REGULATORY STANDARDS..... 33

 11.1 SAFETY 33

12. MECHANICAL CHARACTERISTIC 34

www.panelook.com

REVISION HISTORY

Version	Date	Page (New)	Section	Description
Ver 0.0		All	All	Tentative Specification was first issued.

1. GENERAL DESCRIPTION

1.1 OVERVIEW

V315B1- LE7 is a TFT Liquid Crystal Display module with LED Backlight unit and 2ch-LVDS interface. The display diagonal is 31.5". This module supports 1366x 768 HDTV format and can display true 16.7M colors (6-bit+Hi-FRC colors).

1.2 FEATURES

- Optimized Brightness 350nits
- Contrast Ratio (2000:1)
- Fast Response Time (6.5 ms)
- Color Saturation NTSC 72%
- Full HDTV (1366 x 768 pixels) resolution, true HDTV format
- DE (Data Enable) Only Mode
- LVDS (Low Voltage Differential Signaling) Interface
- Viewing Angle: 176(H)/176(V) (CR>20) MVA Technology
- Color Reproduction (Nature Color)

1.3 APPLICATION

- TFT LCD TVs
- Optimized Brightness, Multi-Media Displays

1.4 GENERAL SPECIFICATIONS

Item	Specification	Unit	Note
Active Area	697.6845(H) x 392.256(V)	mm	(1)
Bezel Opening Area	709.7(H) x405(V)	mm	
Driver Element	a-si TFT active matrix	-	-
Pixel Number	1366x R.G.B. x 768	pixel	-
Pixel Pitch(Sub Pixel)	0.17025 (H) x 0.51075 (V)	mm	-
Pixel Arrangement	RGB vertical stripe	-	-
Display Colors	16.7M	color	-
Display Operation Mode	Transmissive mode / Normally Black	-	-
Surface Treatment	Anti-Glare coating (Haze 11%) Hard Coating (3H)	-	(2)

1.5 MECHANICAL SPECIFICATIONS

Item	Min.	Typ.	Max.	Unit	Note	
Module Size	Horizontal (H)	740.4	741.4	742.4	mm	Module Size
	Vertical (V)	434.8	435.8	436.8	mm	
Weight	Depth (D)	14.2	15.2	16.2	mm	To Rear
	Weight		6000		g	To Boss

Note (1) Please refer to the attached drawings for more information of front and back outline dimensions.

Note (2) Module Depth does not include connectors.

2. ABSOLUTE MAXIMUM RATINGS

2.1 ABSOLUTE RATINGS OF ENVIRONMENT

Item	Symbol	Value		Unit	Note
		Min.	Max.		
Storage Temperature	T_{ST}	-20	+60	°C	(1)
Operating Ambient Temperature	T_{OP}	0	50	°C	(1), (2)
Shock (Non-Operating)	S_{NOP}	-	50	G	(3), (5)
Vibration (Non-Operating)	V_{NOP}	-	1.0	G	(4), (5)

Note (1) Temperature and relative humidity range is shown in the figure below.

(a) 90 %RH Max. ($T_a \leq 40$ °C).

(b) Wet-bulb temperature should be 39 °C Max. ($T_a > 40$ °C).

(c) No condensation.

Note (2) The maximum operating temperature is based on the test condition that the surface temperature of display area is less than or equal to 65 °C with LCD module alone in a temperature controlled chamber. Thermal management should be considered in final product design to prevent the surface temperature of display area from being over 65 °C. The range of operating temperature may degrade in case of improper thermal management in final product design.

Note (3) 11 ms, half sine wave, 1 time for $\pm X$, $\pm Y$, $\pm Z$.

Note (4) 10 ~ 200 Hz, 30 min, 1 time each X, Y, Z.

Note (5) At testing Vibration and Shock, the fixture in holding the module has to be hard and rigid enough so that the module would not be twisted or bent by the fixture.

Relative Humidity (%RH)

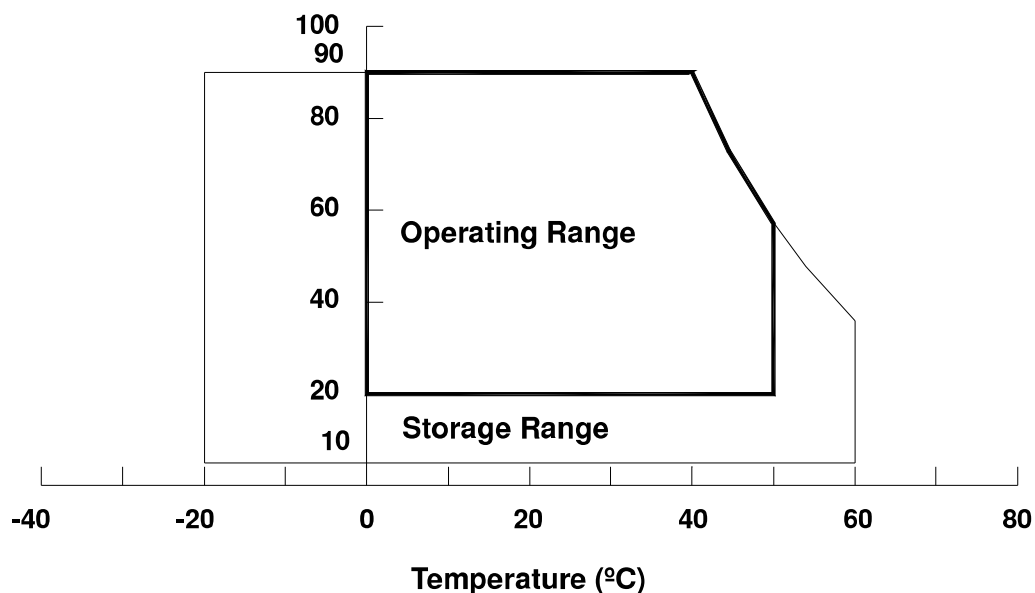

2.2 Package storage

When storing modules as spares for a long time, the following precaution is necessary.

- Do not leave the module in high temperature, and high humidity for a long time. It is highly recommended to store the module with temperature from 0 to 35°C at normal humidity without condensation.
- The module shall be stored in dark place. Do not store the TFT-LCD module in direct sunlight or fluorescent light.

2.3 ELECTRICAL ABSOLUTE RATINGS

2.3.1 TFT LCD MODULE

Item	Symbol	Value		Unit	Note
		Min.	Max.		
Power Supply Voltage	V _{CC}	-0.3	13.0	V	(1)
Input Signal Voltage	V _{IN}	-0.3	3.6	V	

2.3.2 BACKLIGHT CONVERTER UNIT

Item	Symbol	Test Condition	Min.	Type	Max.	Unit	Note
Light Bar Voltage	V _W	Ta = 25 °C	-	-	60	V _{RMS}	
Converter Input Voltage	V _{BL}	-	0	-	30	V	
Control Signal Level	-	-	-0.3	-	7	V	

Note (1) Permanent damage to the device may occur if maximum values are exceeded. Function operation should be restricted to the conditions described under Normal Operating Conditions.

3. ELECTRICAL CHARACTERISTICS

3.1 TFT LCD MODULE

(Ta = 25 ± 2 °C)

Parameter		Symbol	Value			Unit	Note
			Min.	Typ.	Max.		
Power Supply Voltage		V _{CC}	10.8	12	13.2	V	(1)
Rush Current		I _{RUSH}	—	—	2.7	A	(2)
Power Supply Current	White Pattern	—	—	0.58	—	A	(3)
	Black Pattern	—	—	0.44	—	A	
	Horizontal Stripe	—	—	0.58	0.62	A	
LVDS interface	Differential Input High Threshold Voltage	V _{LVTH}	+100	—	—	mV	(4)
	Differential Input Low Threshold Voltage	V _{LVTL}	—	—	-100	mV	
	Common Input Voltage	V _{CM}	1.0	1.2	1.4	V	
	Differential input voltage	V _{ID}	200	—	600	mV	
	Terminating Resistor	R _T	—	100	—	ohm	
CMOS interface	Input High Threshold Voltage	V _{IH}	2.7	—	3.3	V	
	Input Low Threshold Voltage	V _{IL}	0	—	0.7	V	

Note (1) The module should be always operated within above ranges.

Note (2) Measurement Conditions:

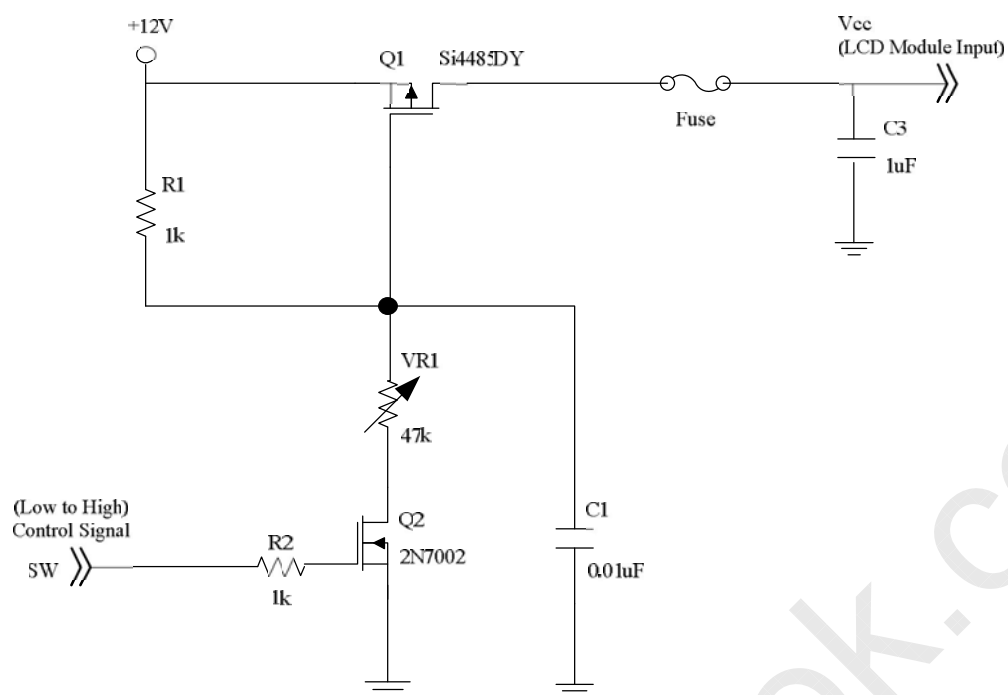

Vcc rising time is 470us

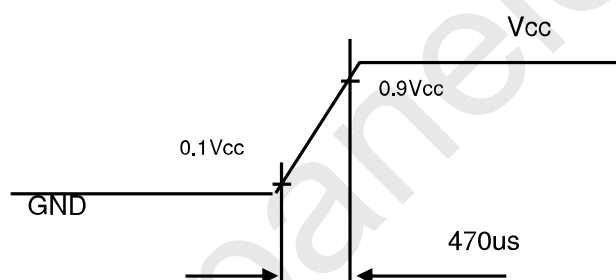

Note (3) The specified power supply current is under the conditions at $V_{cc} = 12\text{ V}$, $T_a = 25 \pm 2\text{ }^\circ\text{C}$, $f_v = 60\text{ Hz}$, whereas a power dissipation check pattern below is displayed.

a. White Pattern



Active Area

b. Black Pattern



Active Area

4. BLOCK DIAGRAM OF INTERFACE

4.1 TFT LCD MODULE

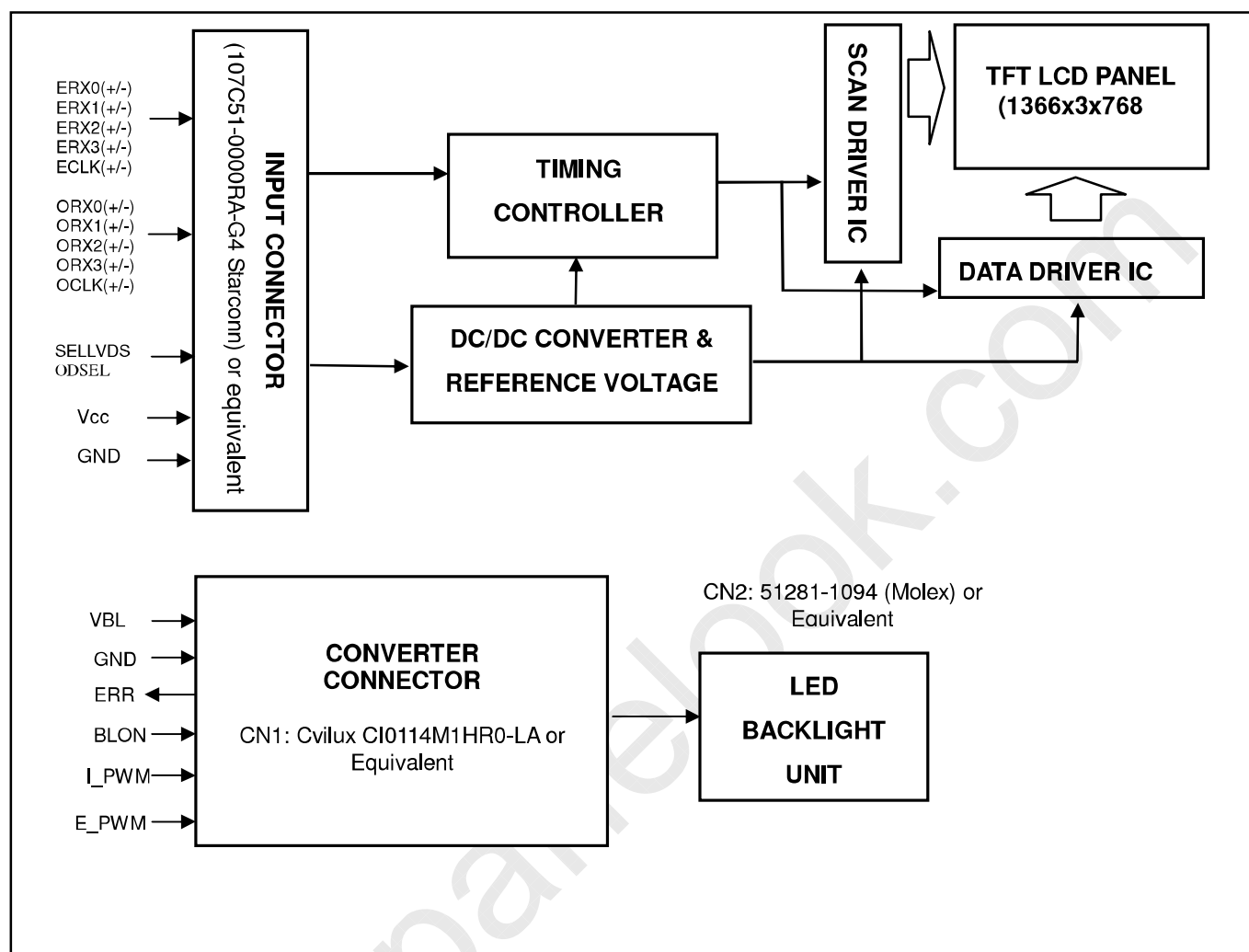

5. INTERFACE PIN CONNECTION

5.1 TFT LCD OPEN CELL

CNF1 Connector Pin Assignment

Pin No.	Symbol	Description	Note
1	VCC	Power supply: +12V	
2	VCC	Power supply: +12V	
3	VCC	Power supply: +12V	
4	VCC	Power supply: +12V	
5	GND	Ground	
6	GND	Ground	
7	GND	Ground	
8	GND	Ground	
9	SELLVDS	Select LVDS data format	(2)
10	ODSEL	Overdrive Lookup Table Selection	(3)
11	GND	Ground	
12	RX0-	Negative transmission data of pixel 0	
13	RX0+	Positive transmission data of pixel 0	
14	GND	Ground	
15	RX1-	Negative transmission data of pixel 1	
16	RX1+	Positive transmission data of pixel 1	
17	GND	Ground	
18	RX2-	Negative transmission data of pixel 2	
19	RX2+	Positive transmission data of pixel 2	
20	GND	Ground	
21	RXCLK-	Negative of clock	
22	RXCLK+	Positive of clock	
23	GND	Ground	
24	RX3-	Negative transmission data of pixel 3	
25	RX3+	Positive transmission data of pixel 3	
26	GND	Ground	
27	TST_AGE	Aging Mode	(4)
28	NC	No connection	(5)
29	GND	Ground	
30	GND	Ground	

Note (1) Connector type: STARCONN 093G30-B0001A or P-TWO 187053-30091 or compatible

Note (2) Ground or OPEN: VESA, High: JEIDA LVDS format

Please refer to 5.3 LVDS INTERFACE

Note (3) Overdrive lookup table selection. The Overdrive lookup table should be selected in accordance to the frame rate to optimize image quality.

ODSEL	Note
L or Open	Lookup table was optimized for 60 Hz frame rate.
H	Lookup table was optimized for 50 Hz frame rate.

Note (4) Ground or OPEN: Disable, High: Enable.

Note (5) Reserved for internal use. Left it open.

5.2 BACKLIGHT UNIT

The pin configuration for the housing and the leader wire is shown in the table below.
 CN: 51281-1094 (Molex) or Equivalent

Pin No	Symbol	Feature
1	N1	Negative of LED String
2	N2	
3	N3	
4	N4	
5	NC	NC
6	VLED+	Positive of LED String
7		
8	NC	NC
9	N5	Negative of LED String
10	N6	
11	N7	
12	N8	

5.3 CONVERTER UNIT

CN1(Header): Cvilux CI0114M1HR0-LA or Equivalent

Pin №	Symbol	Feature
1	VBL	+24V
2		
3		
4		
5		
6	GND	GND
7		
8		
9		
10		
11	ERR	Normal (GND) Abnormal (Open collector)
12	BLON	BL ON/OFF
13	I_PWM	Internal PWM Control
14	E_PWM	External PWM Control

Note (1) PIN 13:Internal PWM Control (Use Pin 13): Pin 14 must open.

Note (2) PIN 14:External PWM Control (Use Pin 14): Pin 13 must open.

Note (3) Pin 13(I_PWM) and Pin 14(E_PWM) can't open in same period.

5.4 BLOCK DIAGRAM OF INTERFACE

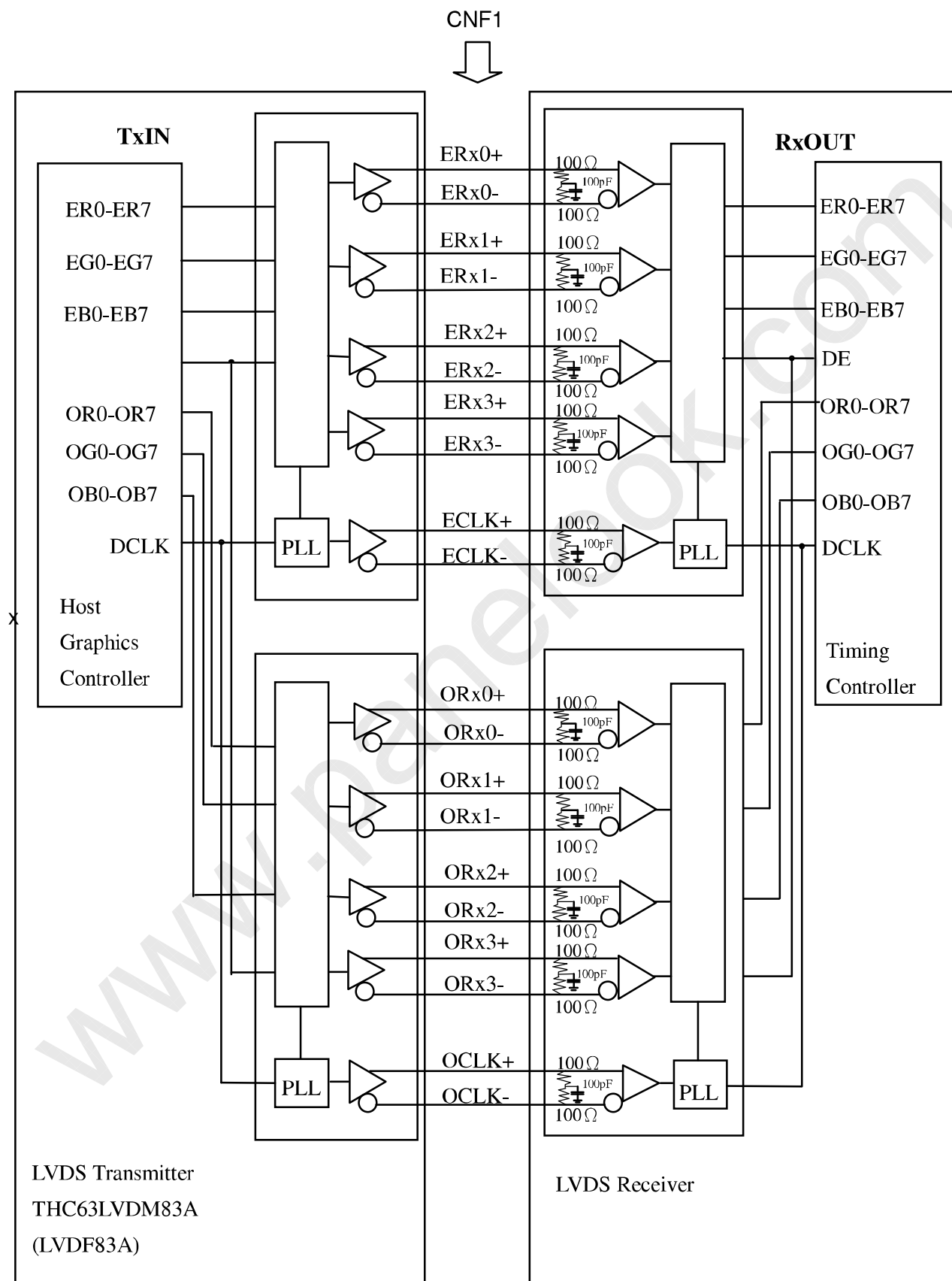

ER0~ER7: Even pixel R data

EG0~EG7: Even pixel G data

EB0~EB7: Even pixel B data

OR0~OR7: Odd pixel R data

OG0~OG7: Odd pixel G data

OB0~OB7: Odd pixel B data

DE: Data enable signal

DCLK: Data clock signal

Note (1) The system must have the transmitter to drive the module.

Note (2) LVDS cable impedance shall be 50 ohms per signal line or about 100 ohms per twist-pair line when it is used differentially.

Note (3) Two pixel data send into the module for every clock cycle. The first pixel of the frame is odd pixel and the second pixel is even pixel.

5.5 LVDS INTERFACE

VESA LVDS format : (SELLVDS pin=L or open)

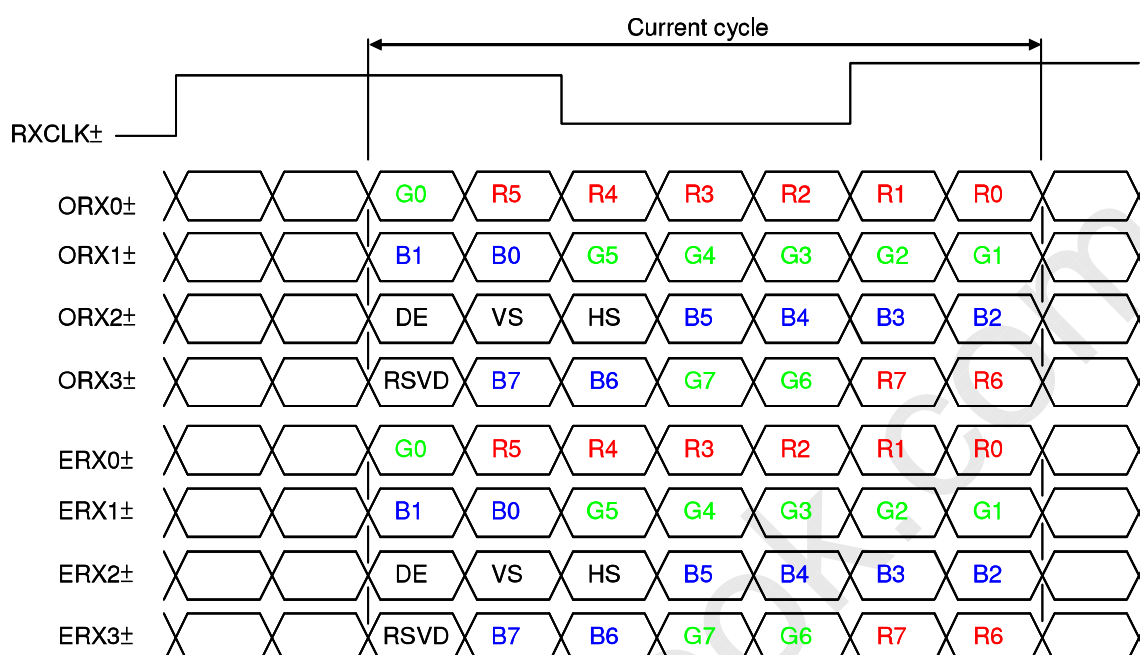

JEDIA LVDS format : (SELLVDS pin=H)

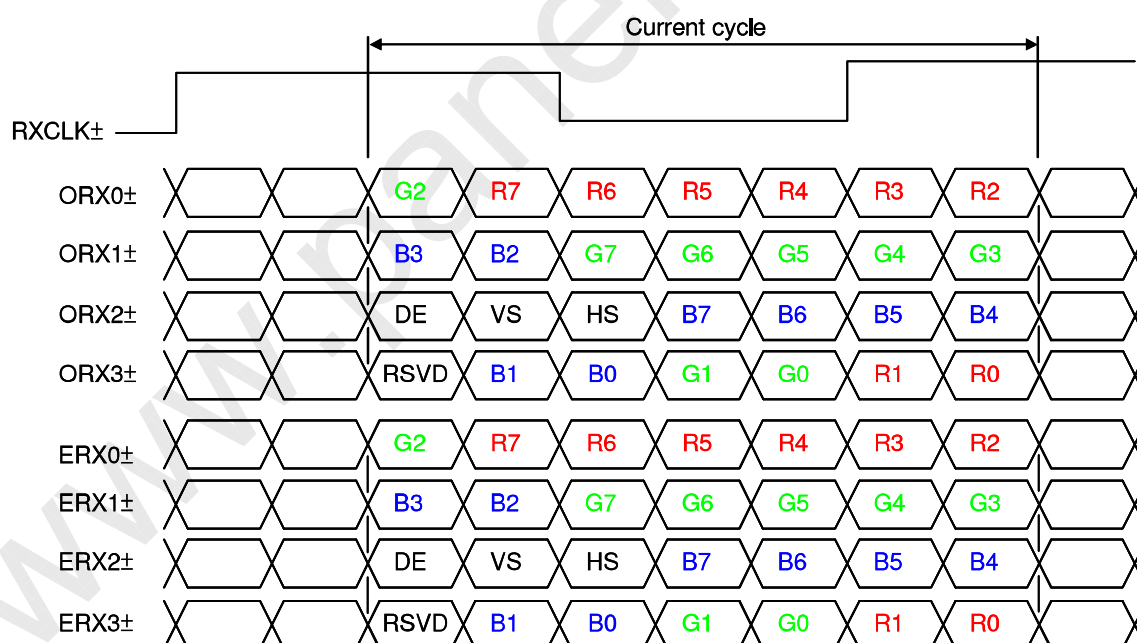

R0~R7: Pixel R Data (7; MSB, 0; LSB)

G0~G7: Pixel G Data (7; MSB, 0; LSB)

B0~B7: Pixel B Data (7; MSB, 0; LSB)

DE : Data enable signal

DCLK : Data clock signal

Notes: (1) RSVD (reserved) pins on the transmitter shall be "H" or "L".



5.6 COLOR DATA INPUT ASSIGNMENT

The brightness of each primary color (red, green and blue) is based on the 8-bit gray scale data input for the color.

The higher the binary input, the brighter the color. The table below provides the assignment of the color versus data input.

Color		Data Signal																							
		Red								Green								Blue							
		R7	R6	R5	R4	R3	R2	R1	R0	G7	G6	G5	G4	G3	G2	G1	G0	B7	B6	B5	B4	B3	B2	B1	B0
Basic Colors	Black	0	0	0	0	0	0	0	0	0	0	0	0	0	0	0	0	0	0	0	0	0	0	0	0
	Red	1	1	1	1	1	1	1	1	0	0	0	0	0	0	0	0	0	0	0	0	0	0	0	0
	Green	0	0	0	0	0	0	0	0	1	1	1	1	1	1	1	1	0	0	0	0	0	0	0	0
	Blue	0	0	0	0	0	0	0	0	0	0	0	0	0	0	0	0	1	1	1	1	1	1	1	1
	Cyan	0	0	0	0	0	0	0	0	1	1	1	1	1	1	1	1	1	1	1	1	1	1	1	1
	Magenta	1	1	1	1	1	1	1	1	0	0	0	0	0	0	0	0	1	1	1	1	1	1	1	1
	Yellow	1	1	1	1	1	1	1	1	1	1	1	1	1	1	1	1	0	0	0	0	0	0	0	0
	White	1	1	1	1	1	1	1	1	1	1	1	1	1	1	1	1	1	1	1	1	1	1	1	1
Gray Scale Of Red	Red(0) / Dark	0	0	0	0	0	0	0	0	0	0	0	0	0	0	0	0	0	0	0	0	0	0	0	0
	Red(1)	0	0	0	0	0	0	0	1	0	0	0	0	0	0	0	0	0	0	0	0	0	0	0	0
	Red(2)	0	0	0	0	0	0	1	0	0	0	0	0	0	0	0	0	0	0	0	0	0	0	0	0
	:	:	:	:	:	:	:	:	:	:	:	:	:	:	:	:	:	:	:	:	:	:	:	:	:
	:	:	:	:	:	:	:	:	:	:	:	:	:	:	:	:	:	:	:	:	:	:	:	:	:
	Red(253)	1	1	1	1	1	1	0	1	0	0	0	0	0	0	0	0	0	0	0	0	0	0	0	0
	Red(254)	1	1	1	1	1	1	1	0	0	0	0	0	0	0	0	0	0	0	0	0	0	0	0	0
	Red(255)	1	1	1	1	1	1	1	1	0	0	0	0	0	0	0	0	0	0	0	0	0	0	0	0
Gray Scale Of Green	Green(0) / Dark	0	0	0	0	0	0	0	0	0	0	0	0	0	0	0	0	0	0	0	0	0	0	0	0
	Green(1)	0	0	0	0	0	0	0	0	0	0	0	0	0	0	1	0	0	0	0	0	0	0	0	0
	Green(2)	0	0	0	0	0	0	0	0	0	0	0	0	0	1	0	0	0	0	0	0	0	0	0	0
	:	:	:	:	:	:	:	:	:	:	:	:	:	:	:	:	:	:	:	:	:	:	:	:	:
	:	:	:	:	:	:	:	:	:	:	:	:	:	:	:	:	:	:	:	:	:	:	:	:	:
	Green(253)	0	0	0	0	0	0	0	1	1	1	1	1	1	1	0	1	0	0	0	0	0	0	0	0
	Green(254)	0	0	0	0	0	0	0	1	1	1	1	1	1	1	1	0	0	0	0	0	0	0	0	0
	Green(255)	0	0	0	0	0	0	0	1	1	1	1	1	1	1	1	1	0	0	0	0	0	0	0	0
Gray Scale Of Blue	Blue(0) / Dark	0	0	0	0	0	0	0	0	0	0	0	0	0	0	0	0	0	0	0	0	0	0	0	0
	Blue(1)	0	0	0	0	0	0	0	0	0	0	0	0	0	0	0	0	0	0	0	0	0	0	0	1
	Blue(2)	0	0	0	0	0	0	0	0	0	0	0	0	0	0	0	0	0	0	0	0	0	0	1	0
	:	:	:	:	:	:	:	:	:	:	:	:	:	:	:	:	:	:	:	:	:	:	:	:	:
	:	:	:	:	:	:	:	:	:	:	:	:	:	:	:	:	:	:	:	:	:	:	:	:	:
	Blue(253)	0	0	0	0	0	0	0	0	0	0	0	0	0	0	0	0	1	1	1	1	1	1	0	1
	Blue(254)	0	0	0	0	0	0	0	0	0	0	0	0	0	0	0	0	1	1	1	1	1	1	1	0
	Blue(255)	0	0	0	0	0	0	0	0	0	0	0	0	0	0	0	0	1	1	1	1	1	1	1	1

Note (1) 0: Low Level Voltage, 1: High Level Voltage

6. INTERFACE TIMING

6.1 INPUT SIGNAL TIMING SPECIFICATIONS

(Ta = 25 ± 2 °C)

The input signal timing specifications are shown as the following table and timing diagram.

Signal	Item	Symbol	Min.	Typ.	Max.	Unit	Note
LVDS Receiver Clock	Frequency	$F_{clk_{in}}$ (=1/TC)	60	74.25	80	MHz	
	Input cycle to cycle jitter	T_{rcj}	—	—	200	ps	(3)
	Spread spectrum modulation range	$F_{clk_{in_mod}}$	$F_{clk_{in}}-2\%$	—	$F_{clk_{in}}+2\%$	MHz	(4)
	Spread spectrum modulation frequency	F_{SSM}	—	—	200	KHz	
LVDS Receiver Data	Setup Time	$Tlvsu$	600	—	—	ps	(5)
	Hold Time	$Tlvhd$	600	—	—	ps	
Vertical Active Display Term	Frame Rate	F_{r5}	47	50	53	Hz	(6)
		F_{r6}	57	60	63	Hz	
	Total	T_v	1115	1125	1135	Th	$T_v=T_{vd}+T_{vb}$
	Display	T_{vd}	1080	1080	1080	Th	—
	Blank	T_{vb}	35	45	55	Th	—
Horizontal Active Display Term	Total	T_h	1050	1100	1150	Tc	$T_h=T_{hd}+T_{hb}$
	Display	T_{hd}	960	960	960	Tc	—
	Blank	T_{hb}	90	140	190	Tc	—

Note (1) Please make sure the range of pixel clock has follow the below equation :

$$F_{clk_{in}}(\max) \geq F_{r6} \times T_v \times T_h$$

$$F_{r5} \times T_v \times T_h \geq F_{clk_{in}}(\min)$$

Note (2) This module is operated in DE only mode and please follow the input signal timing diagram below :

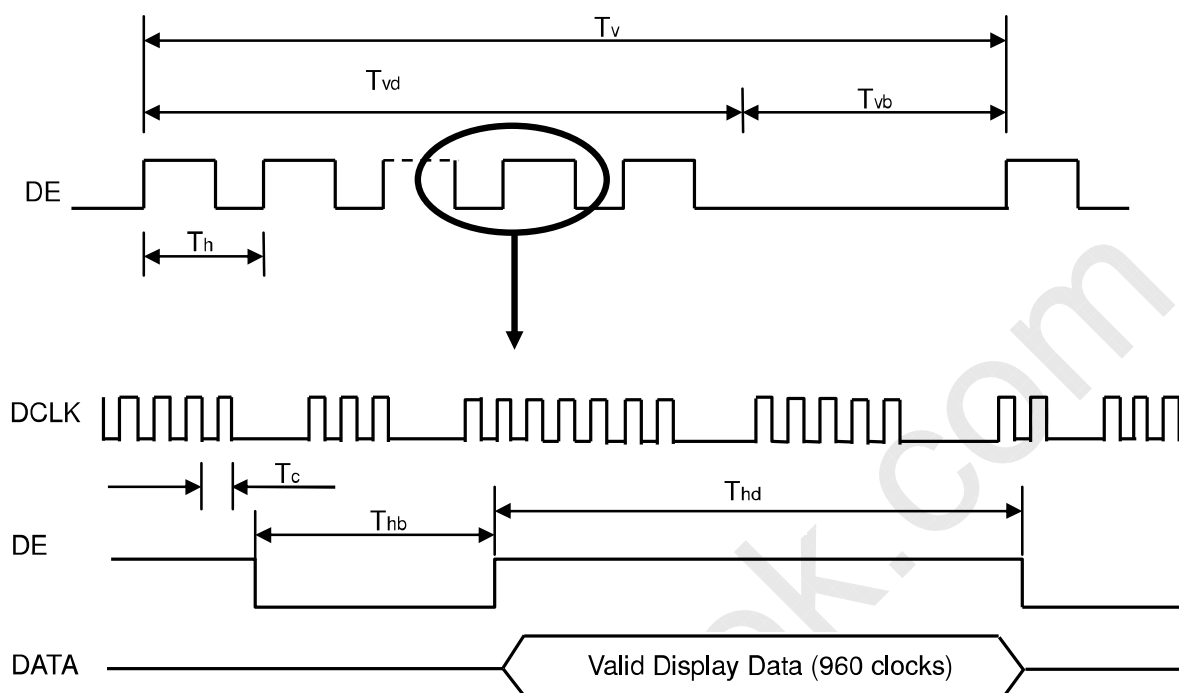
INPUT SIGNAL TIMING DIAGRAM

Note (3) The input clock cycle-to-cycle jitter is defined as below figures. $Trcl = |T_1 - T_1|$

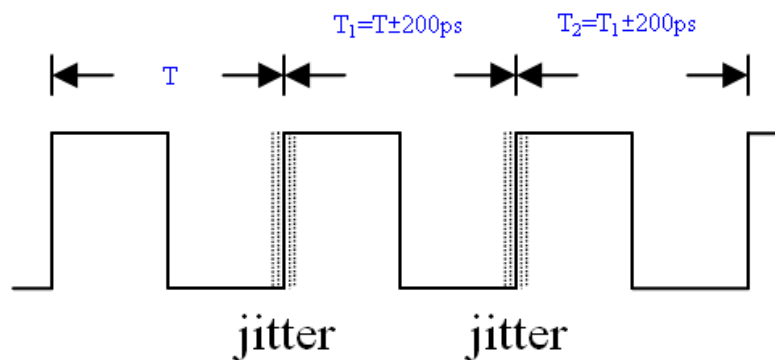

Note (4) The SSCG (Spread spectrum clock generator) is defined as below figures.

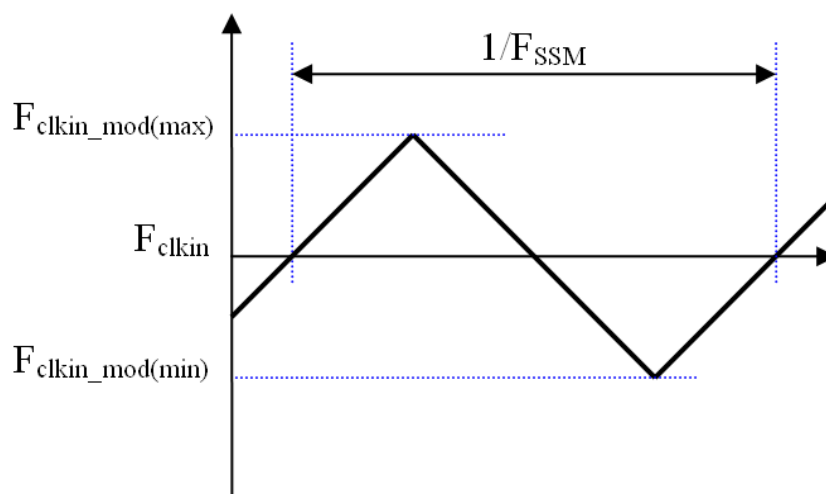

Note (5) The LVDS timing diagram and setup/hold time is defined and showing as the following figures.

LVDS RECEIVER INTERFACE TIMING DIAGRAM

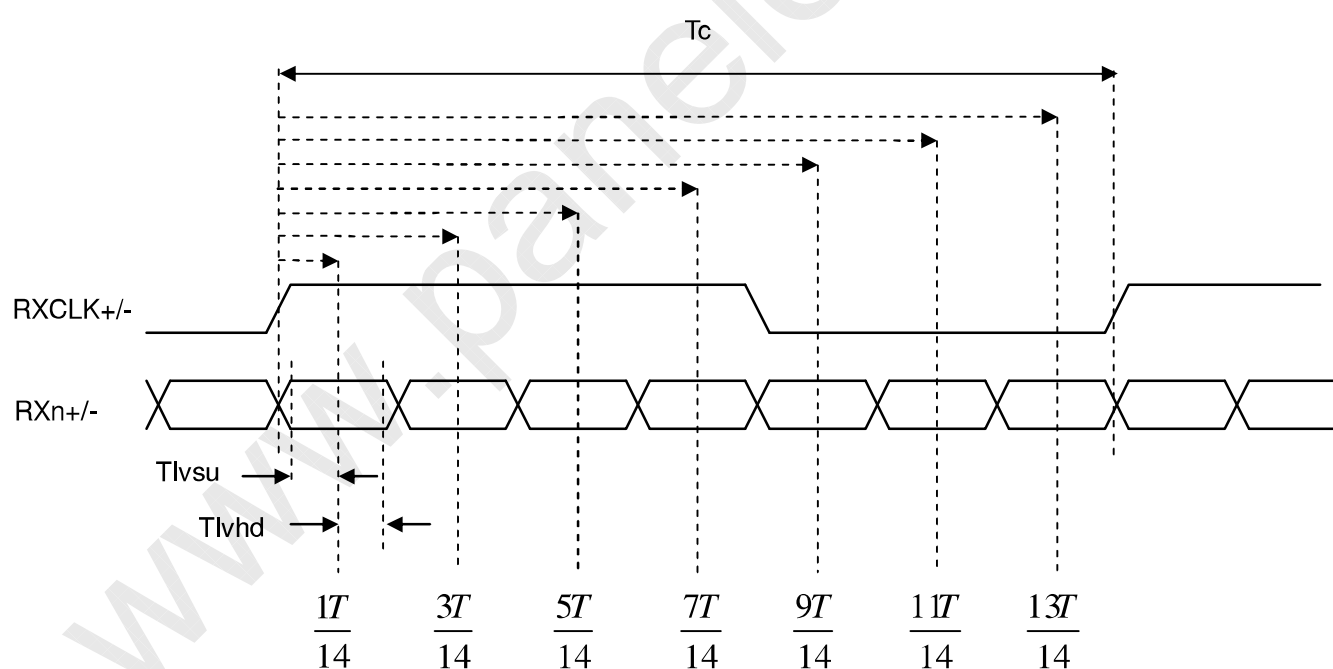

Note (6) (ODSEL) = H/L or open for 50/60Hz frame rate. Please refer to 5.1 for detail information

6.2 POWER ON/OFF SEQUENCE

($T_a = 25 \pm 2 \text{ }^\circ\text{C}$)

To prevent a latch-up or DC operation of LCD module, the power on/off sequence should be as the diagram below.

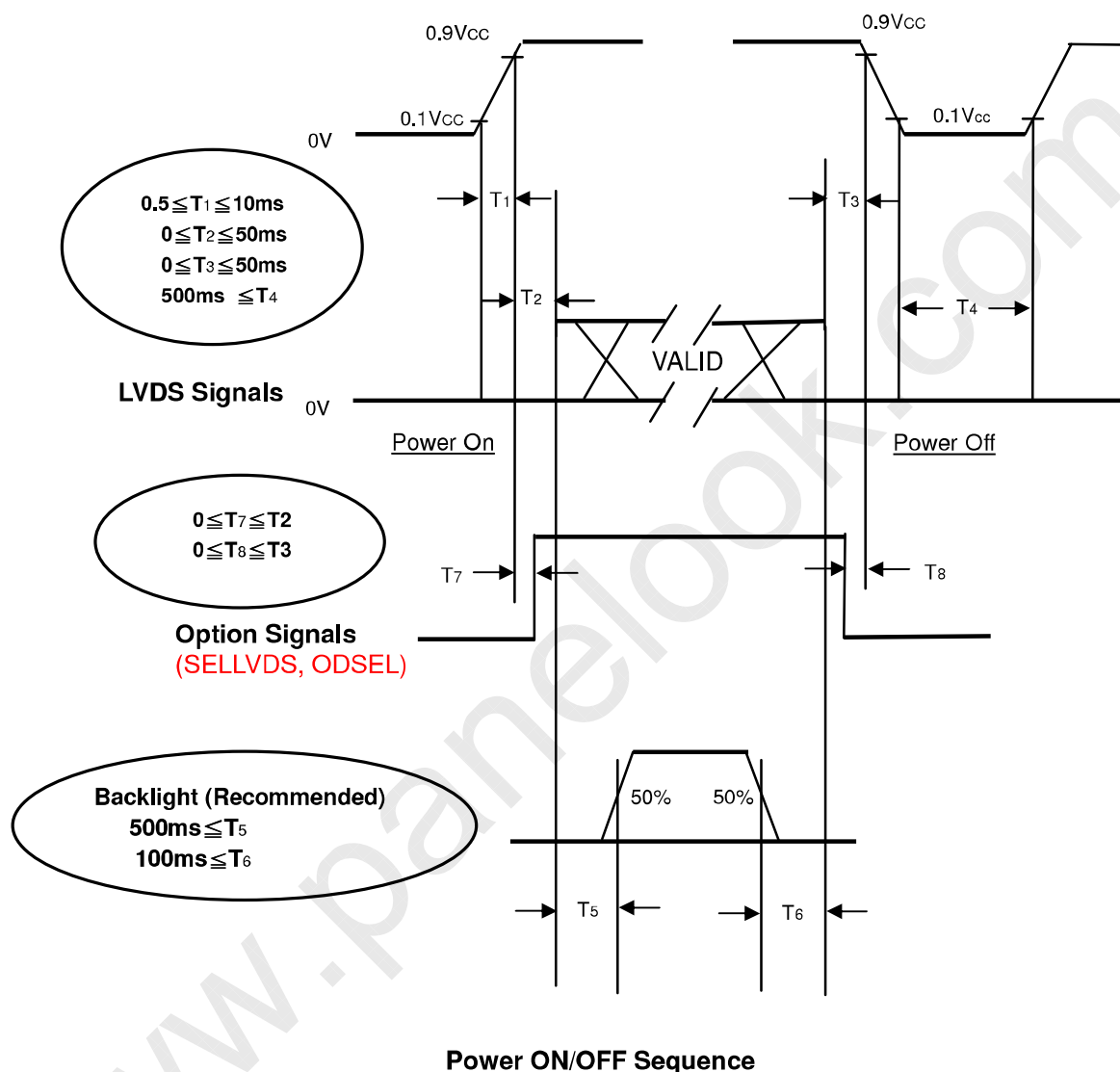

Note (1) The supply voltage of the external system for the module input should follow the definition of V_{cc} .

Note (2) Apply the LED voltage within the LCD operation range. When the backlight turns on before the LCD operation or the LCD turns off before the backlight turns off, the display may momentarily become abnormal screen.

Note (3) In case of V_{cc} is in off level, please keep the level of input signals on the low or high impedance. If $T_2 < 0$, that maybe cause electrical overstress failure.

Note (4) T_4 should be measured after the module has been fully discharged between power off and on period.

Note (5) Interface signal shall not be kept at high impedance when the power is on.

7. OPTICAL CHARACTERISTICS

7.1 TEST CONDITIONS

Item	Symbol	Value	Unit
Ambient Temperature	Ta	25±2	°C
Ambient Humidity	Ha	50±10	%RH
Supply Voltage	V _{CC}	12V	V
Input Signal	According to typical value in "3. ELECTRICAL CHARACTERISTICS"		
LED Current	I _L	60±5.0	mA

7.2 OPTICAL SPECIFICATIONS

The relative measurement methods of optical characteristics are shown in 7.2. The following items should be measured under the test conditions described in 7.1 and stable environment shown in Note (6).

Item		Symbol	Condition	Min.	Typ.	Max.	Unit	Note		
Contrast Ratio		CR	$\theta_x=0^\circ, \theta_y=0^\circ$ Viewing Angle at Normal Direction	(1000)	(2000)		-	(2)		
Response Time		Gray to gray average			(6.5)	(12)	ms	(3)		
Center Luminance of White		L _c		(300)	(350)		cd/m ²	(4)		
White Variation		δW		-	-	1.3	-	(7)		
Cross Talk		CT		-	-	4.0	%	(5)		
Color Chromaticity	Red	R _x		Typ -0.03		Typ +0.03		-	(6)	
		R _y						(0.629)		-
	Green	G _x						(0.336)		-
		G _y						(0.339)		-
	Blue	B _x						(0.616)		-
		B _y	(0.154)					-		
	White	W _x	(0.034)					-		
W _y	(0.313)	-								
Color Gamut	CG	(0.329)		(70)	%	NTSC				
Viewing Angle	Horizontal	θ_{x+}	CR≥20	80	88	-	Deg.	(1)		
		θ_{x-}		80	88	-				
	Vertical	θ_{y+}		80	88	-				
		θ_{y-}		80	88	-				

Note (1) Definition of Viewing Angle (θ_x, θ_y):

Viewing angles are measured by Autronic Conoscope Cono-80

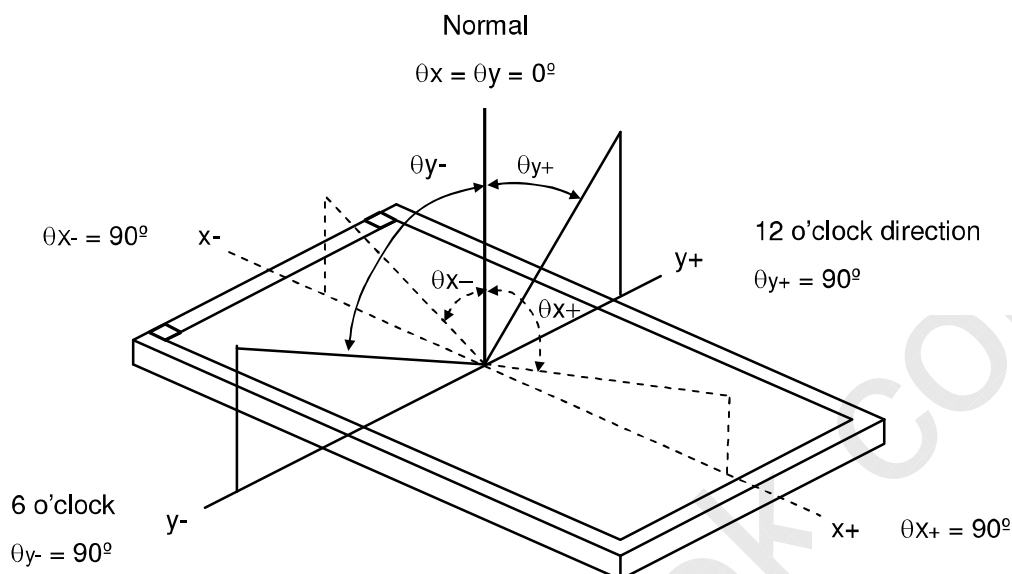

Note (2) Definition of Contrast Ratio (CR):

The contrast ratio can be calculated by the following expression.

$$\text{Contrast Ratio (CR)} = L_{255} / L_0$$

L₂₅₅: Luminance of gray level 255

L₀: Luminance of gray level 0

CR = CR (X), where CR (X) is corresponding to the Contrast Ratio of the point X at the figure in Note (7)

Note (3) Definition of Response Time (Gray to Gray switching time):

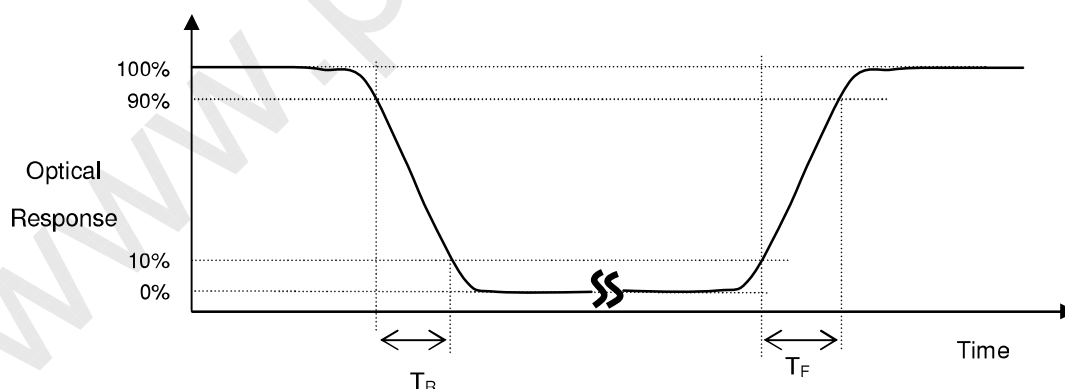

The driving signal means the signal of Gray 0, 31, 63, 95, 127, 159, 191, 223, 255. Gray to gray average time means the average switching time of gray 0, 31, 63, 95, 127, 159, 191, 223, 255 to each other.

Note (4) Definition of Luminance of White (L_c):

Measure the luminance of gray level 255 at center point.

$L_c = L (5)$, where L (x) is corresponding to the luminance of the point X at the figure in Note (7).

Note (5) Definition of Cross Talk (CT):

$$CT = |Y_B - Y_A| / Y_A \times 100 (\%)$$

Where:

Y_A = Luminance of measured location without gray level 0 pattern (cd/m^2)

Y_B = Luminance of measured location with gray level 0 pattern (cd/m^2)

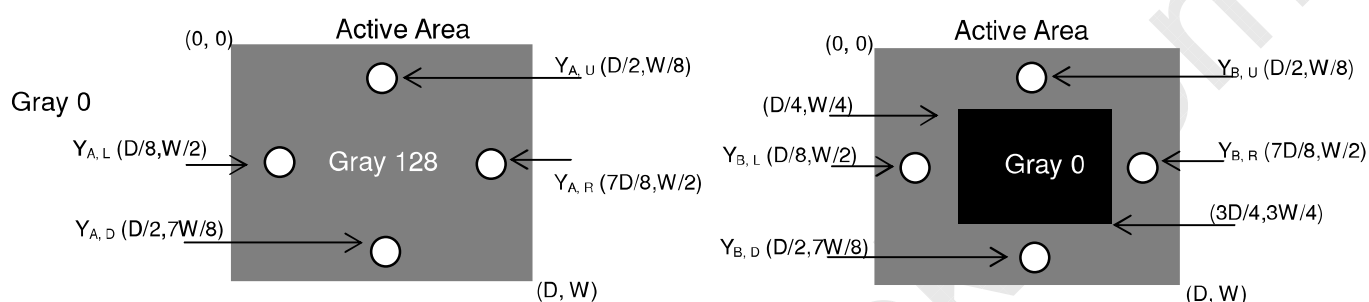

Note (6) Measurement Setup:

The LCD module should be stabilized at given temperature for 1 hour to avoid abrupt temperature change during measuring. In order to stabilize the luminance, the measurement should be executed after lighting backlight for 1 hour in a windless room.

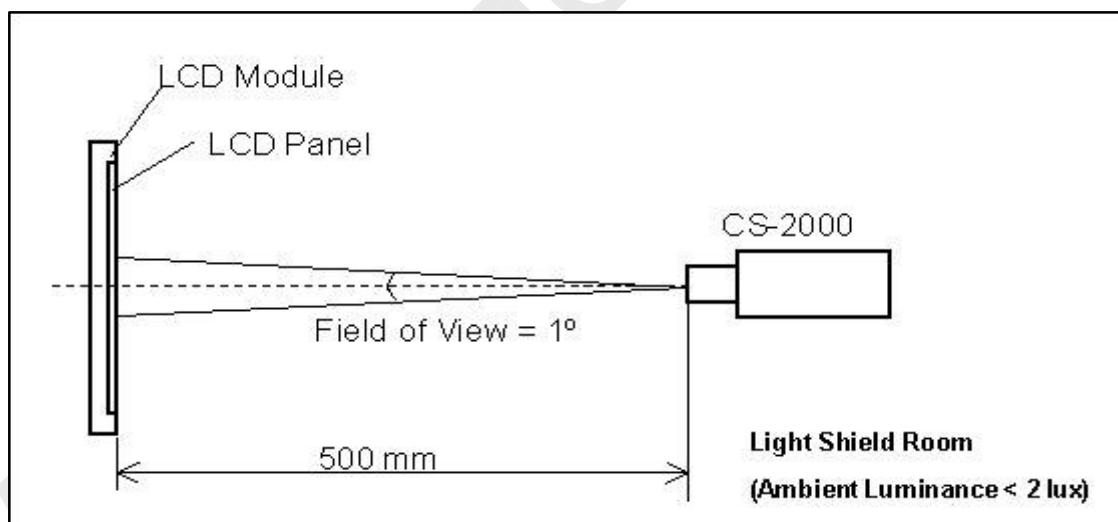

Note (7) Definition of White Variation (δW):

Measure the luminance of gray level 255 at 5 points

$$\delta W = \text{Maximum [L (1), L (2), L (3), L (4), L (5)]} / \text{Minimum [L (1), L (2), L (3), L (4), L (5)]}$$

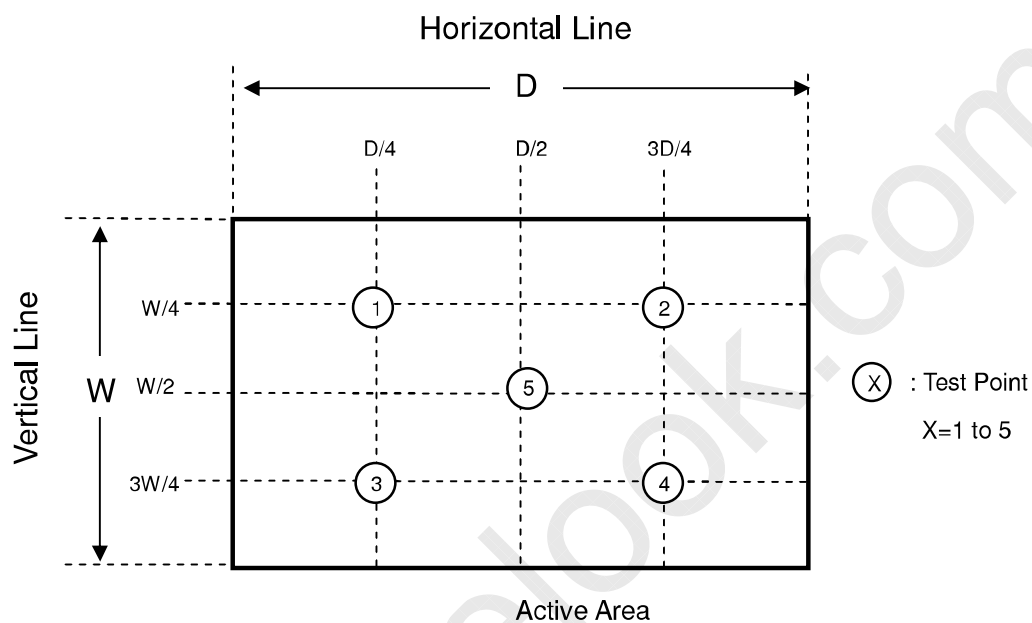

8. DEFINITION OF LABELS

8.1 CMO MODULE LABEL

The barcode nameplate is pasted on each module as illustration, and its definitions are as following explanation.

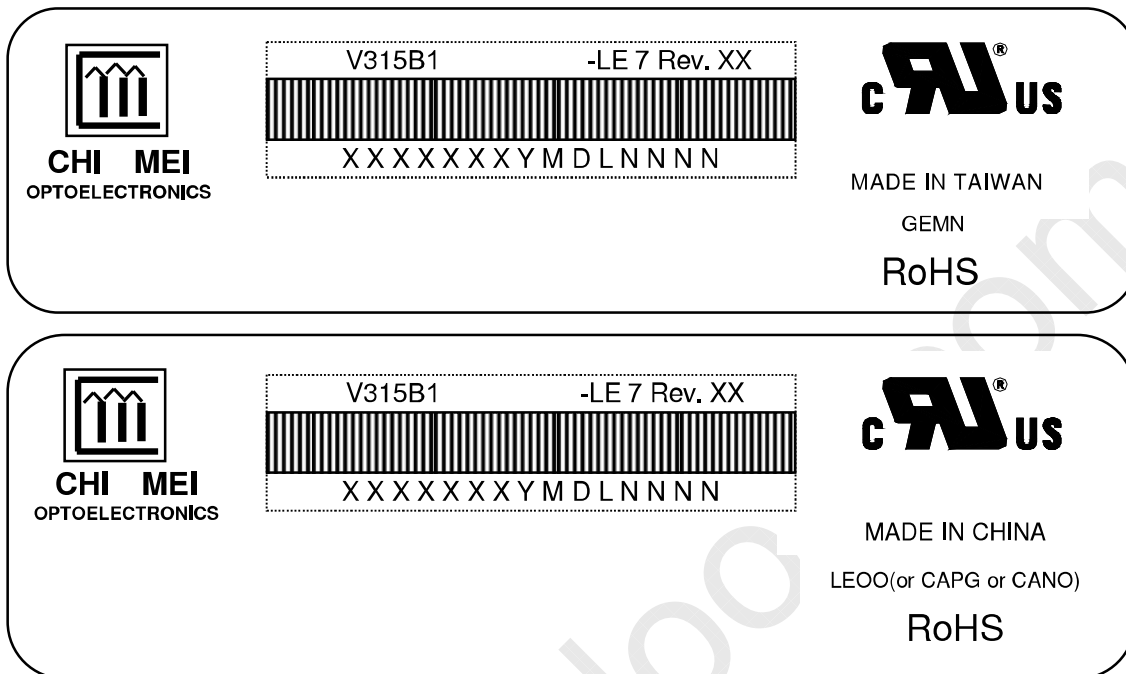

- (a) Model Name: V315B1-LE7
- (b) Revision: Rev. XX, for example: A0, A1... B1, B2... or C1, C2...etc.
- (c) Serial ID: XXXXXXXXYMDLNNNN

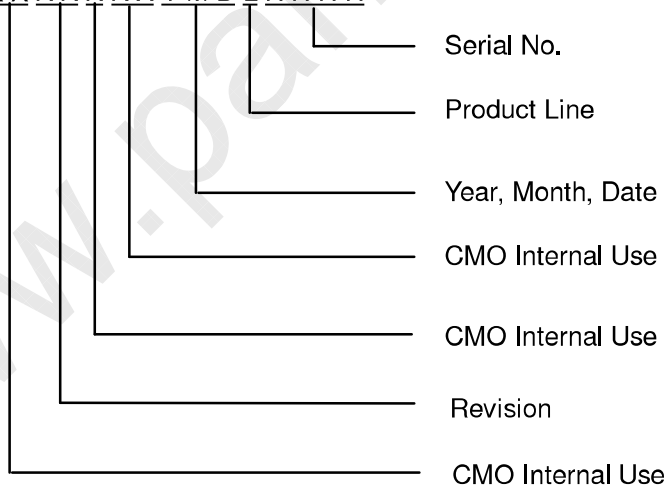

Serial ID includes the information as below:

- (a) Manufactured Date: Year: 0~9, for 2010~2019
Month: 1~9, A~C, for Jan. ~ Dec.
Day: 1~9, A~Y, for 1st to 31st, exclude I, O, and U.
- (b) Revision Code: Cover all the change
- (c) Serial No.: Manufacturing sequence of product
- (d) Product Line: 1 -> Line1, 2 -> Line 2, ...etc.

9. PACKAGING

9.1 PACKING SPECIFICATIONS

- (1) 4 LCD TV modules / 1 Box
- (2) Box dimensions : 826(L)x376(W)x540(H)mm
- (3) WEIGHT : APPROXIMATELY 50 KG (7 MODULES PER BOX)

9.2 PACKING METHOD

Figures 9-1 and 9-2 are the packing method

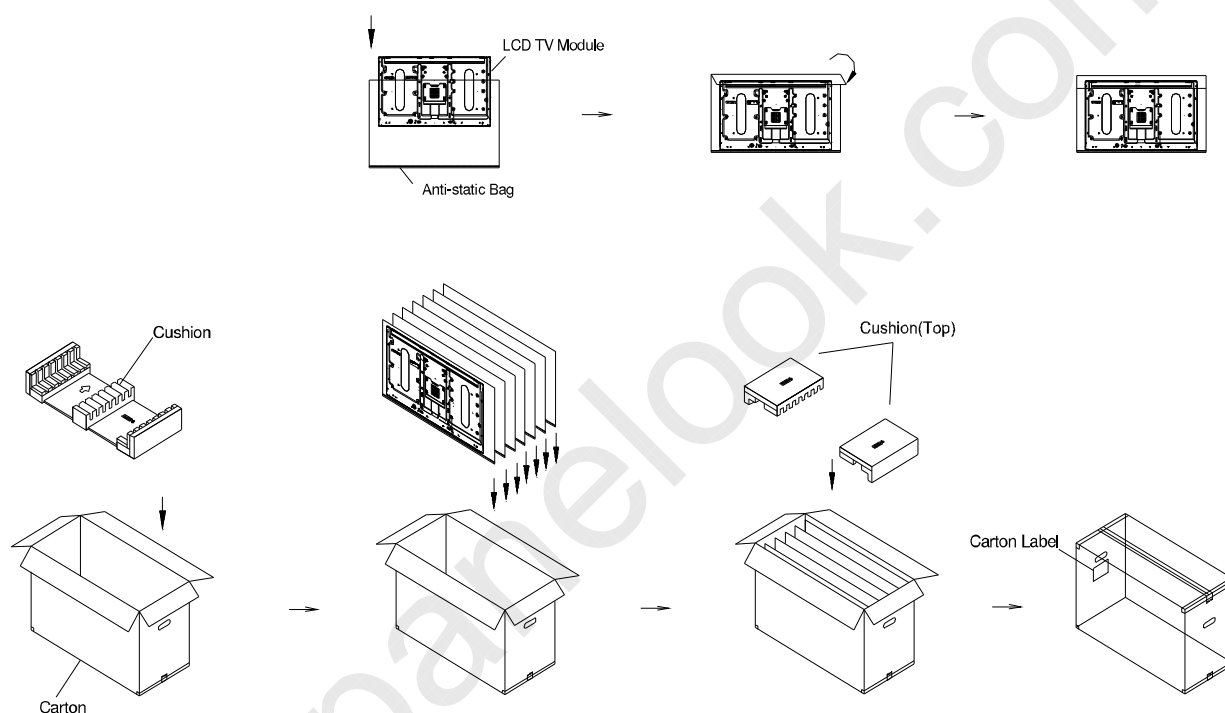
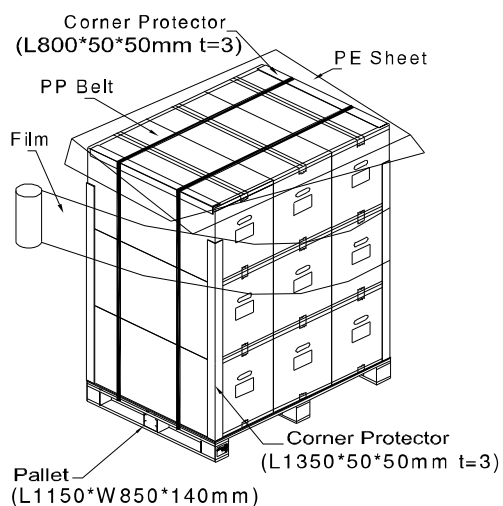
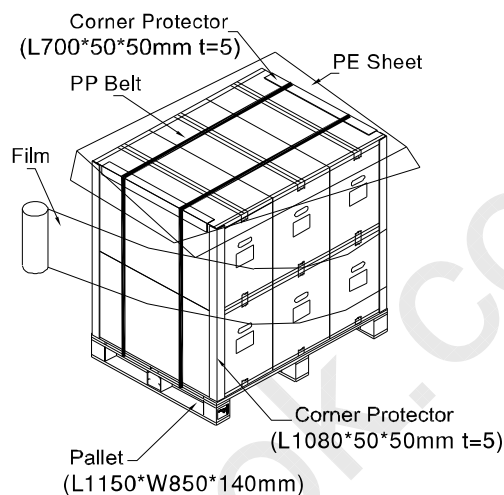

Figure.9-1 packing method

Sea / Land Transportation (40ft Container)



Air Transportation



Sea / Land Transportation (40ft HQ Container)

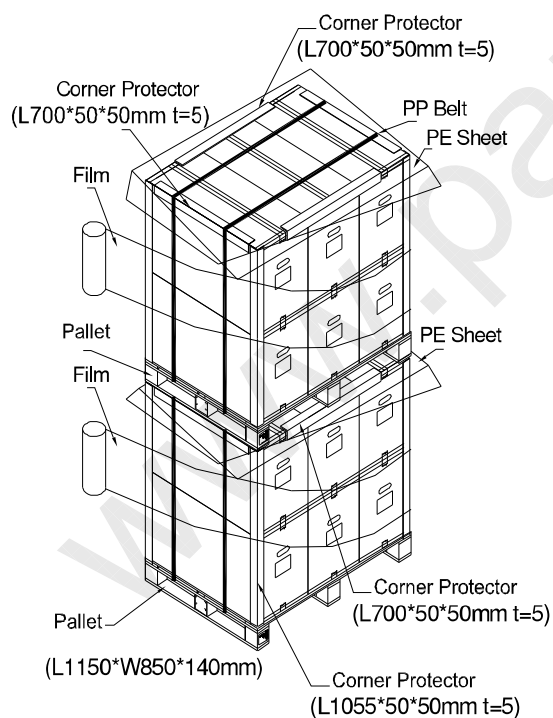

Figure. 9-2 Packing method

10. PRECAUTIONS

10.1 ASSEMBLY AND HANDLING PRECAUTIONS

- (1) Do not apply rough force such as bending or twisting to the module during assembly.
- (2) It is recommended to assemble or to install a module into the user's system in clean working areas. The dust and oil may cause electrical short or worsen the polarizer.
- (3) Do not apply pressure or impulse to the module to prevent the damage of LCD panel and backlight.
- (4) Always follow the correct power-on sequence when the LCD module is turned on. This can prevent the damage and latch-up of the CMOS LSI chips.
- (5) Do not plug in or pull out the I/F connector while the module is in operation.
- (6) Do not disassemble the module.
- (7) Use a soft dry cloth without chemicals for cleaning, because the surface of polarizer is very soft and easily scratched.
- (8) Moisture can easily penetrate into LCD module and may cause the damage during operation.
- (9) High temperature or humidity may deteriorate the performance of LCD module. Please store LCD modules in the specified storage conditions.
- (10) When ambient temperature is lower than 10°C, the display quality might be reduced. For example, the response time will become slow.

10.2 SAFETY PRECAUTIONS

- (1) The startup voltage of a backlight is over 1000 Volts. It may cause an electrical shock while assembling with the inverter. Do not disassemble the module or insert anything into the backlight unit.
- (2) If the liquid crystal material leaks from the panel, it should be kept away from the eyes or mouth. In case of contact with hands, skin or clothes, it has to be washed away thoroughly with soap.
- (3) After the module's end of life, it is not harmful in case of normal operation and storage.

10.3 STORAGE PRECAUTIONS

When storing modules as spares for a long time, the following precaution is necessary.

- (1) Do not leave the module in high temperature, and high humidity for a long time.
It is highly recommended to store the module with temperature from 0 to 35°C at normal humidity without condensation.
- (2) The module shall be stored in dark place. Do not store the TFT-LCD module in direct sunlight or fluorescent light.

11. REGULATORY STANDARDS

11.1 SAFETY

The LCD module should be certified with safety regulations as follows:

Requirement	Standard	Remark
UL	UL60950-1:2006 or Ed.2:2007	
	UL60065 Ed.7:2007	
cUL/CSA	CAN/CSA C22.2 No.60950-1-03 or 60950-1-07	
	CAN/CSA C22.2 No.60065-03:2006 + A1:2006	
CB	IEC60950-1:2005 / EN60950-1:2006+ A11:2009	
	IEC60065:2001+ A1:2005 / EN60065:2002 + A1:2006 + A11:2008	

12. MECHANICAL CHARACTERISTIC

