

## TFT LCD Approval Specification

# MODEL NO.: V315B5 - L05

Customer: \_\_\_\_\_

Approved by: \_\_\_\_\_

\_\_\_\_\_

\_\_\_\_\_

Note:

Approved By	TV Head Division	
	CC Chung	

Reviewed By	QA Dept.	Product Development Div.
	Hsin-nan Chen	WT Lin

Prepared By	LCD TV Marketing and Product Management Div.	
	CY Chang Kevin Tsai	

## CONTENTS -

REVISION HISTORY	-----	3
1. GENERAL DESCRIPTION	-----	4
1.1 OVERVIEW		
1.2 FEATURES		
1.3 APPLICATION		
1.4 GENERAL SPECIFICATIONS		
1.5 MECHANICAL SPECIFICATIONS		
2. ABSOLUTE MAXIMUM RATINGS	-----	5
2.1 ABSOLUTE RATINGS OF ENVIRONMENT		
2.2 PACKAGE STORAGE		
2.3 ELECTRICAL ABSOLUTE RATINGS		
2.3.1 TFT LCD MODULE		
2.3.2 BACKLIGHT UNIT		
2.4 ENVIRONMENT TEST CONDITION		
3. ELECTRICAL CHARACTERISTICS	-----	8
3.1 TFT LCD MODULE		
3.2 BACKLIGHT INVERTER UNIT		
3.2.1 CCFL(Cold Cathode Fluorescent Lamp) CHARACTERISTICS		
3.2.2 INVERTER CHARACTERISTICS		
3.2.3 INVERTER INTERFACE CHARACTERISTICS		
4. BLOCK DIAGRAM	-----	14
4.1 TFT LCD MODULE		
5. INTERFACE PIN CONNECTION	-----	15
5.1 TFT LCD MODULE		
5.2 BACKLIGHT UNIT		
5.3 INVERTER UNIT		
5.4 BLOCK DIAGRAM OF INTERFACE		
5.5 LVDS INTERFACE		
5.6 COLOR DATA INPUT ASSIGNMENT		
6. INTERFACE TIMING	-----	21
6.1 INPUT SIGNAL TIMING SPECIFICATIONS		
6.2 POWER ON/OFF SEQUENCE		
7. OPTICAL CHARACTERISTICS	-----	24
7.1 TEST CONDITIONS		
7.2 OPTICAL SPECIFICATIONS		
8. DEFINITION OF LABELS	-----	28
8.1 CMO MODULE LABEL		
9. PACKAGING	-----	30
9.1 PACKING SPECIFICATIONS		
9.2 PACKING METHOD		
10. PRECAUTIONS	-----	32
10.1 ASSEMBLY AND HANDLING PRECAUTIONS		
10.2 SAFETY PRECAUTIONS		
10.3 SAFETY STANDARDS		
10.4 EMC		
11. MECHANICAL CHARACTERISTICS	-----	34

**REVISION HISTORY**

Version	Date	Page (New)	Section	Description
Ver 2.0	Jun 15,2009	All	All	Approval Specification was first issued.
Ver 2.1	July 1,2009	7	2-4	Add ENVIRONMENT TEST CONDITION
		33	10-3	Add SAFETY STANDARDS
Ver 2.2	July 2,2009	33	10.4	Add EMC

## 1. GENERAL DESCRIPTION

### 1.1 OVERVIEW

V315B5- L05 is a 31.5" TFT Liquid Crystal Display module with 4U-type CCFL Backlight unit and 1ch-LVDS interface. This module supports 1366 x 768 WXGA format and can display 16.7M (6-bit+Hi-FRC) colors. The inverter module for backlight is built-in.

### 1.2 FEATURES

- High brightness (450 nits)
- Ultra-high contrast ratio (3000:1)
- Fast response time (gray to gray average 8.5ms)
- High color saturation NTSC 72%
- Ultra wide viewing angle : 176(H)/176(V) (CR $\geq$ 20) with Super MVA technology
- DE (Data Enable) only mode
- LVDS (Low Voltage Differential Signaling) interface
- Color reproduction (nature color)

### 1.3 APPLICATION

- TFT LCD TVs
- Multi-Media Display

### 1.4 GENERAL SPECIFICATIONS

Item	Specification	Unit	Note
Active Area	697.6845 (H) x 392.256 (V) (31.51" diagonal)	mm	(1)
Bezel Opening Area	703.8 (H) x 398.4 (V)	mm	
Driver Element	a-si TFT active matrix	-	
Pixel Number	1366 x R.G.B. x 768	pixel	
Pixel Pitch (Sub Pixel)	0.17025(H) x 0.51075 (V)	mm	
Pixel Arrangement	RGB vertical stripe	-	
Display Colors	16.7M	color	
Display Operation Mode	Transmissive mode / Normally black	-	
Surface Treatment	Anti-Glare coating (Haze 11%),Hard coating (3H)	-	

### 1.5 MECHANICAL SPECIFICATIONS

Item	Min.	Typ.	Max.	Unit	Note	
Module Size	Horizontal(H)	759	760	761	mm	(1)
	Vertical(V)	449	450	451	mm	(1)
	Depth(D)	31.5	32.5	33.5	mm	To Rear
	Depth(D)	49.2	50.2	51.2	mm	To inverter cover
Weight	--	5390	--	g		

Note (1) Please refer to the attached drawings for more information of front and back outline dimensions.

## 2. ABSOLUTE MAXIMUM RATINGS

### 2.1 ABSOLUTE RATINGS OF ENVIRONMENT

Item	Symbol	Value		Unit	Note
		Min.	Max.		
Storage Temperature	T <sub>ST</sub>	-20	+60	°C	(1)
Operating Ambient Temperature	T <sub>OP</sub>	0	+50	°C	(1), (2)
Shock (Non-Operating)	S <sub>NOF</sub>	-	50	G	(3), (5)
Vibration (Non-Operating)	V <sub>NOF</sub>	-	1.0	G	(4), (5)

Note (1) Temperature and relative humidity range is shown in the figure below.

(a) 90 %RH Max. ( $T_a \leq 40$  °C).

(b) Wet-bulb temperature should be 39 °C Max. ( $T_a > 40$  °C).

(c) No condensation.

Note (2) The maximum operating temperature is based on the test condition that the surface temperature of display area is less than or equal to 65 °C with LCD module alone in a temperature controlled chamber. Thermal management should be considered in final product design to prevent the surface temperature of display area from being over 65 °C. The range of operating temperature may degrade in case of improper thermal management in final product design.

Note (3) 11 ms, half sine wave, 1 time for  $\pm X$ ,  $\pm Y$ ,  $\pm Z$ .

Note (4) 10 ~ 200 Hz, 10 min, 1 time each X, Y, Z.

Note (5) At testing Vibration and Shock, the fixture in holding the module has to be hard and rigid enough so that the module would not be twisted or bent by the fixture.

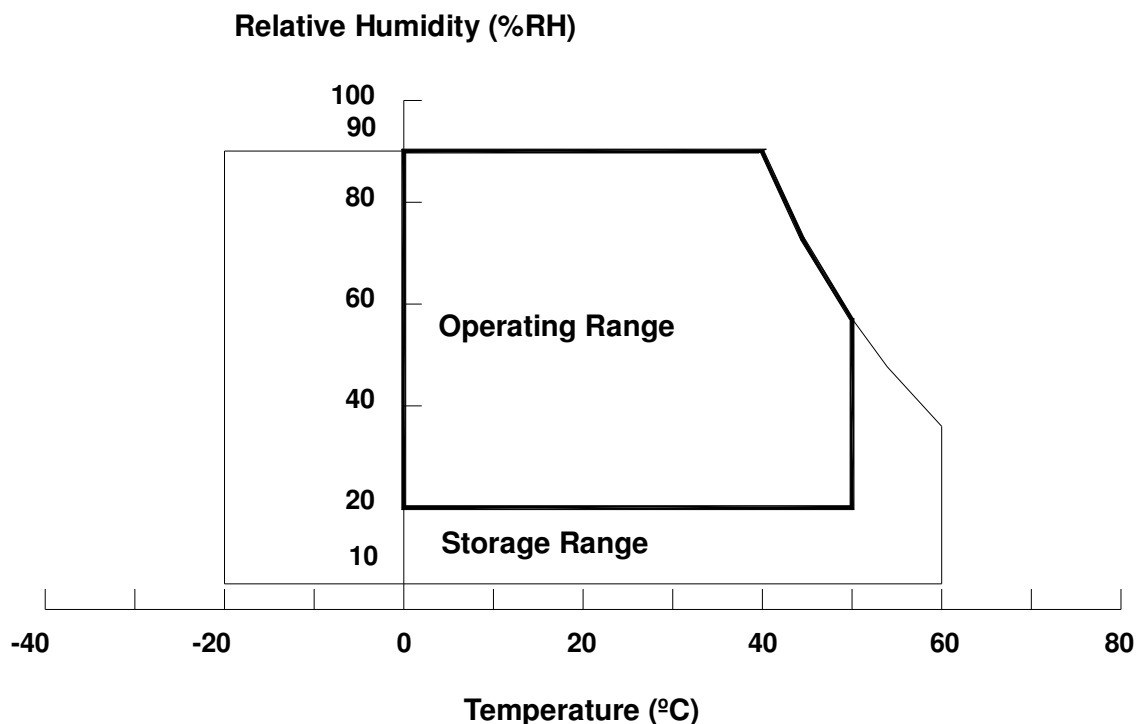

## 2.2 Package storage

When storing modules as spares for a long time, the following precaution is necessary.

- (a) Do not leave the module in high temperature, and high humidity for a long time. It is highly recommended to store the module with temperature from 0 to 35°C at normal humidity without condensation.
- (b) The module shall be stored in dark place. Do not store the TFT-LCD module in direct sunlight or fluorescent light.

## 2.3 ELECTRICAL ABSOLUTE RATINGS

### 2.3.1 TFT LCD MODULE

Item	Symbol	Value		Unit	Note
		Min.	Max.		
Power Supply Voltage	V <sub>CC</sub>	-0.3	13.0	V	(1)
Input Signal Voltage	V <sub>IN</sub>	-0.3	3.6	V	

### 2.3.2 BACKLIGHT UNIT

Item	Symbol	Value		Unit	Note
		Min.	Max.		
Lamp Voltage	V <sub>W</sub>	—	3000	V <sub>RMS</sub>	
Power Supply Voltage	V <sub>BL</sub>	0	30	V	(1)
Control Signal Level	—	-0.3	7	V	(1), (3)

Note (1) Permanent damage to the device may occur if maximum values are exceeded. Functional operation should be restricted to the conditions described under normal operating conditions.

Note (2) No moisture condensation or freezing.

Note (3) The control signals include On/Off Control, Internal PWM Control, External PWM Control.

## 2.4 ENVIRONMENT TEST CONDITION

No.	Test Item	Condition
1	High temperature storage test	Ta=60°C 500hrs
2	Low temperature storage test	Ta= -25°C 500hrs
3	High temperature high humidity storage test	Ta= 50°C 90%RH 500hrs
4	High temperature operation test	Ta= 50°C 500hrs
5	Low temperature operation test	Ta=0°C 500hrs
6	High temperature high humidity Operation	Ta= 40°C 95%RH 500hrs
7	Thermal shock	Ta= -20°C/ 30min~60°C/ 30min 100cycles
8	Vibration test (non-operation)	Wave form: Sine wave Vibration level: 1.0G Freq. range: 10~500Hz Duration: X, Y, Z, 60min, One time each direction
9	Shock test (non-operation)	Wave form: half sine wave, 11ms Shock level: 50G ±X, ±Y, ±Z, One time each direction
10	ESD	Storage: Contact mode +/-20kV, Air mode +/-20kV Operation: Contact mode +/-20kV, Air mode +/-20kV Condition: 150pF, 330ohm (Follow IEC 6100-4-2 standard)
11	Package Vibration	Wave form: Sine wave Vibration level: 1.0G Freq. range: 5~50Hz Duration: 15min for X, Y, 60 min for Z. One time each direction
12	Package Drop	Drop 1 corner, 3 sides, 6 faces, each one for 1 time. Height is 30cm. (Test environment: 25°C)

### 3. ELECTRICAL CHARACTERISTICS

#### 3.1 TFT LCD MODULE

 $T_a = 25 \pm 2 \text{ }^\circ\text{C}$ 

Parameter		Symbol	Value			Unit	Note
			Min.	Typ.	Max.		
Power Supply Voltage		$V_{CC}$	11.4	12.0	12.6	V	(1)
Power Supply Ripple Voltage		$V_{RP}$	-	-	100	mV	
Rush Current		$I_{RUSH}$	-	-	3.4	A	(2)
Power Supply Current	White	$I_{CC}$	-	0.42	0.5	A	(3)
	Black		-	0.28	-	A	
	Vertical Stripe		-	0.4	-	A	
LVDS Interface	Differential Input High Threshold Voltage	$V_{LVTH}$	+100	-		mV	
	Differential Input Low Threshold Voltage	$V_{LVTL}$		-	-100	mV	
	Common Input Voltage	$V_{LVC}$	1.125	1.25	1.375	V	
	Terminating Resistor	$R_T$	-	100	-	ohm	
CMOS interface	Input High Threshold Voltage	$V_{IH}$	2.7	-	3.3	V	
	Input Low Threshold Voltage	$V_{IL}$	0	-	0.7	V	

Note (1) The module should be always operated within above ranges.

Note (2) Measurement Conditions:

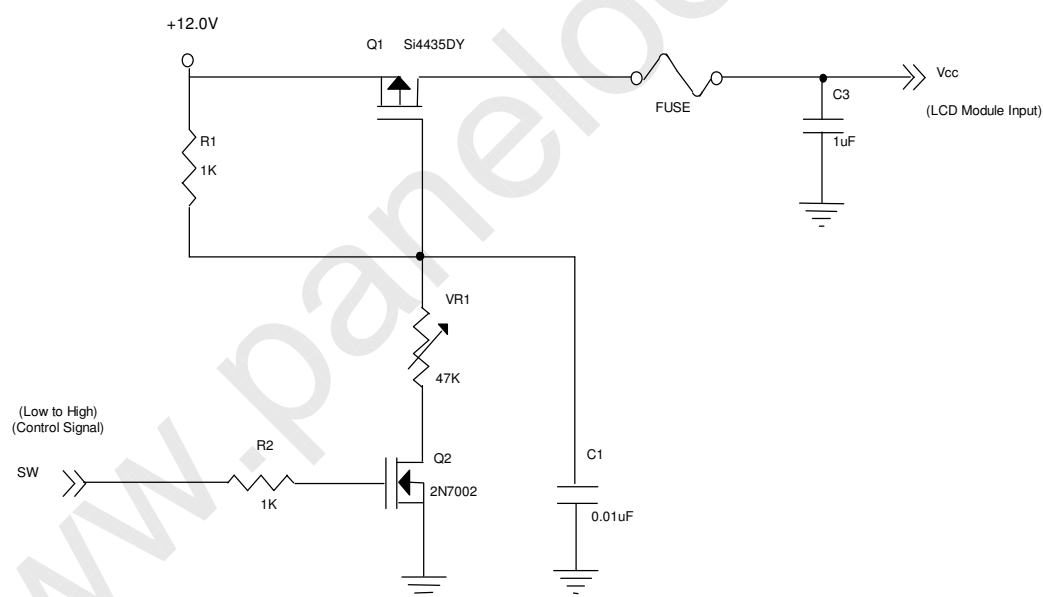

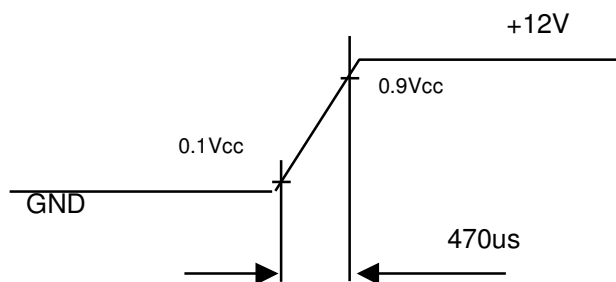

**Vcc rising time is 470us**

Note (3) The specified power supply current is under the conditions at  $V_{cc} = 12V$ ,  $T_a = 25 \pm 2 \text{ }^\circ\text{C}$ ,  $f_v = 60 \text{ Hz}$ , whereas a power dissipation check pattern below is displayed.

a. White Pattern



Active Area

b. Black Pattern



Active Area

c. Vertical Stripe Pattern

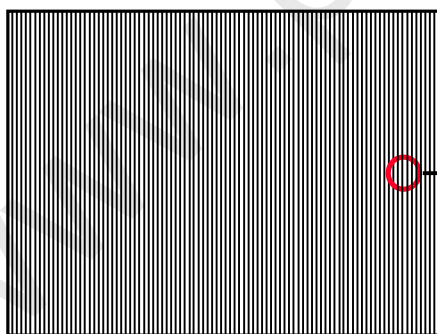

Active Area

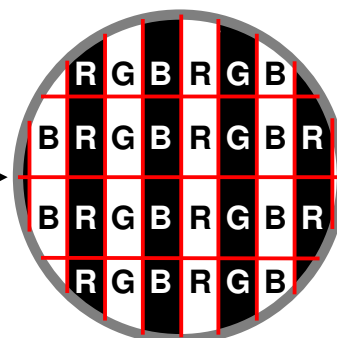

### 3.2 BACKLIGHT INVERTER UNIT

#### 3.2.1 CCFL (Cold Cathode Fluorescent Lamp) CHARACTERISTICS (Ta = 25 ± 2 °C)

Parameter	Symbol	Value			Unit	Note
		Min.	Typ.	Max.		
Lamp Voltage	V <sub>W</sub>	-	1550	-	V <sub>RMS</sub>	I <sub>L</sub> = 10.5mA
Lamp Current	I <sub>L</sub>	10	10.5	11	mA <sub>RMS</sub>	(1)
Lamp Starting Voltage	V <sub>S</sub>	-	-	2700	V <sub>RMS</sub>	(2), Ta = 0 °C
		-	-	2290	V <sub>RMS</sub>	(2), Ta = 25 °C
Operating Frequency	F <sub>O</sub>	30	-	80	KHz	
Lamp Life Time	L <sub>BL</sub>	50,000	-	-	Hrs	(4)

#### 3.2.2 INVERTER CHARACTERISTICS (Ta = 25 ± 2 °C)

Parameter	Symbol	Value			Unit	Note
		Min.	Typ.	Max.		
Power Consumption	P <sub>BL</sub>	-	65	69	W	(5),(6), I <sub>L</sub> = 10.5mA
Input Voltage	V <sub>BL</sub>	22.8	24	25.2	V <sub>DC</sub>	
Input Current	I <sub>BL</sub>	-	2.71	2.88	A	Non Dimming
Input Ripple Noise	-	-	-	912	mV <sub>P-P</sub>	V <sub>BL</sub> =22.8V
Oscillating Frequency	F <sub>W</sub>	60	63	66	kHz	(3)
Dimming frequency	F <sub>B</sub>	150	160	170	Hz	
Minimum Duty Ratio	D <sub>MIN</sub>	-	20	-	%	

**Note (1)** Lamp current is measured by utilizing **AC current probe Tektronix P6022** as shown below:

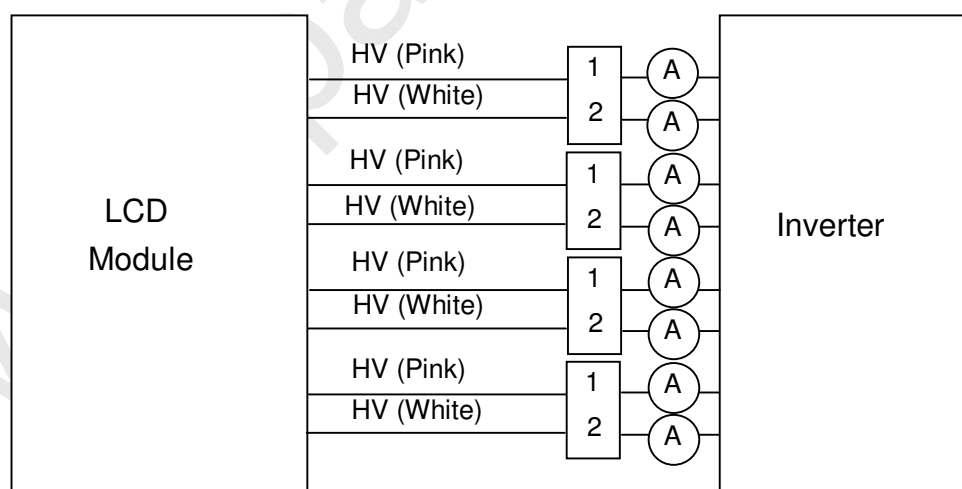

- Note (2)** The lamp starting voltage  $V_s$  should be applied to the lamp for more than 1 second under starting up duration. Otherwise the lamp could not be lighted on completed.
- Note (3)** The lamp frequency may produce interference with horizontal synchronous frequency of the display input signals, and it may result in line flow on the display. In order to avoid interference, the lamp frequency should be detached from the horizontal synchronous frequency and its harmonics as far as possible.
- Note (4)** The life time of a lamp is defined as when the brightness is larger than 50% of its original value and the effective discharge length is longer than 80% of its original length (Effective discharge length is defined as an area that has equal to or more than 70% brightness compared to the brightness at the center point of lamp.) as the time in which it continues to operate under the condition at  $T_a = 25 \pm 2$  °C and  $I_L = 10.0 \sim 11.0 \text{ mA}_{\text{RMS}}$ .
- Note (5)** The power supply capacity should be higher than the total inverter power consumption  $P_{\text{BL}}$ . Since the pulse width modulation (PWM) mode was applied for backlight dimming, the driving current changed as PWM duty on and off. The transient response of power supply should be considered for the changing loading when inverter dimming.
- Note (6)** The measurement condition of Max. value is based on 31.5" backlight unit under input voltage 24V, average lamp current 10.8 mA and lighting 30 minutes later.

### 3.2.3 INVERTER INTERFACE CHARACTERISTICS

Parameter	Symbol	Test Condition	Value			Unit	Note	
			Min.	Typ.	Max.			
On/Off Control Voltage	ON	$V_{BLON}$	—	2.0	—	5.0	V	
	OFF		—	0	—	0.8	V	
Internal PWM Control Voltage	MAX	$V_{IPWM}$	—	3.0	3.15	3.3	V	Maximum duty ratio
	MIN		—	—	0	—	V	Minimum duty ratio
External PWM Control Voltage	HI	$V_{EPWM}$	—	2.0	—	5.0	V	Duty on
	LO		—	0	—	0.8	V	Duty off
Error Signal	HI	ERR	—	3.0	3.3	3.6	V	Abnormal
	LO		—	0	—	0.8	V	Normal
VBL Rising Time	$T_{r1}$	—	30	—	—	ms	10%-90% $V_{BL}$	
VBL Falling Time	$T_{f1}$	—	30	—	—	ms		
Control Signal Rising Time	$T_r$	—	—	—	100	ms		
Control Signal Falling Time	$T_f$	—	—	—	100	ms		
PWM Signal Rising Time	$T_{PWR}$	—	—	—	50	us		
PWM Signal Falling Time	$T_{PWF}$	—	—	—	50	us		
Input impedance	$R_{IN}$	—	1	—	—	MΩ		
PWM Delay Time	$T_{PWM}$	—	100	—	—	ms		
BLON Delay Time	$T_{on}$	—	300	—	—	ms		
	$T_{on1}$	—	300	—	—	ms		
BLON Off Time	$T_{off}$	—	300	—	—	ms		

Note (1) The Dimming signal should be valid before backlight turns on by BLON signal. It is inhibited to change the internal/external PWM signal during backlight turn on period.

Note (2) The power sequence and control signal timing are shown in the following figure. For a certain reason, the inverter has a possibility to be damaged with wrong power sequence and control signal timing.

Note (3) While system is turned ON or OFF, the power sequences must follow as below descriptions:

Turn ON sequence: VBL → PWM signal → BLON

Turn OFF sequence: BLOFF → PWM signal → VBL

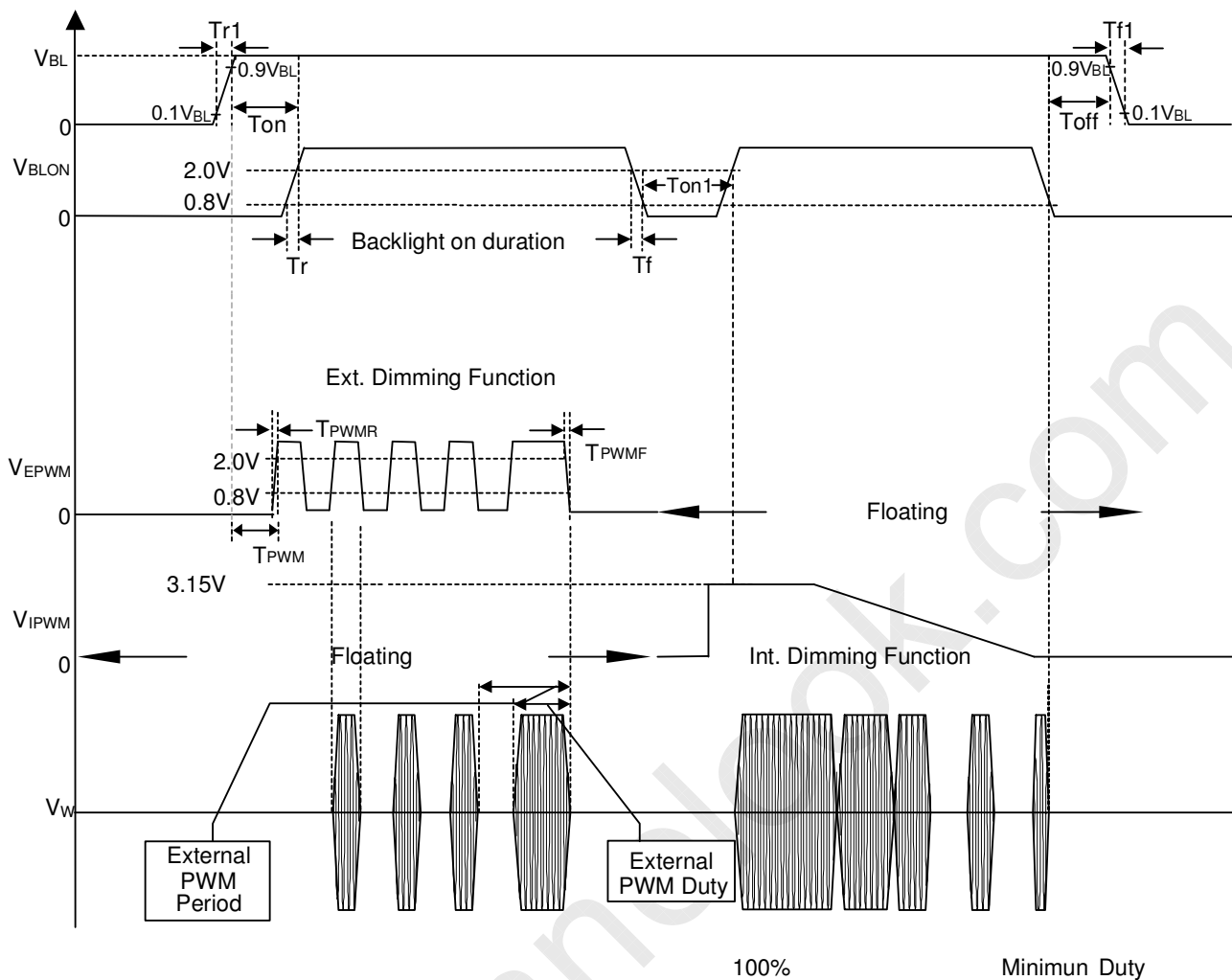

## 4. BLOCK DIAGRAM

### 4.1 TFT LCD MODULE

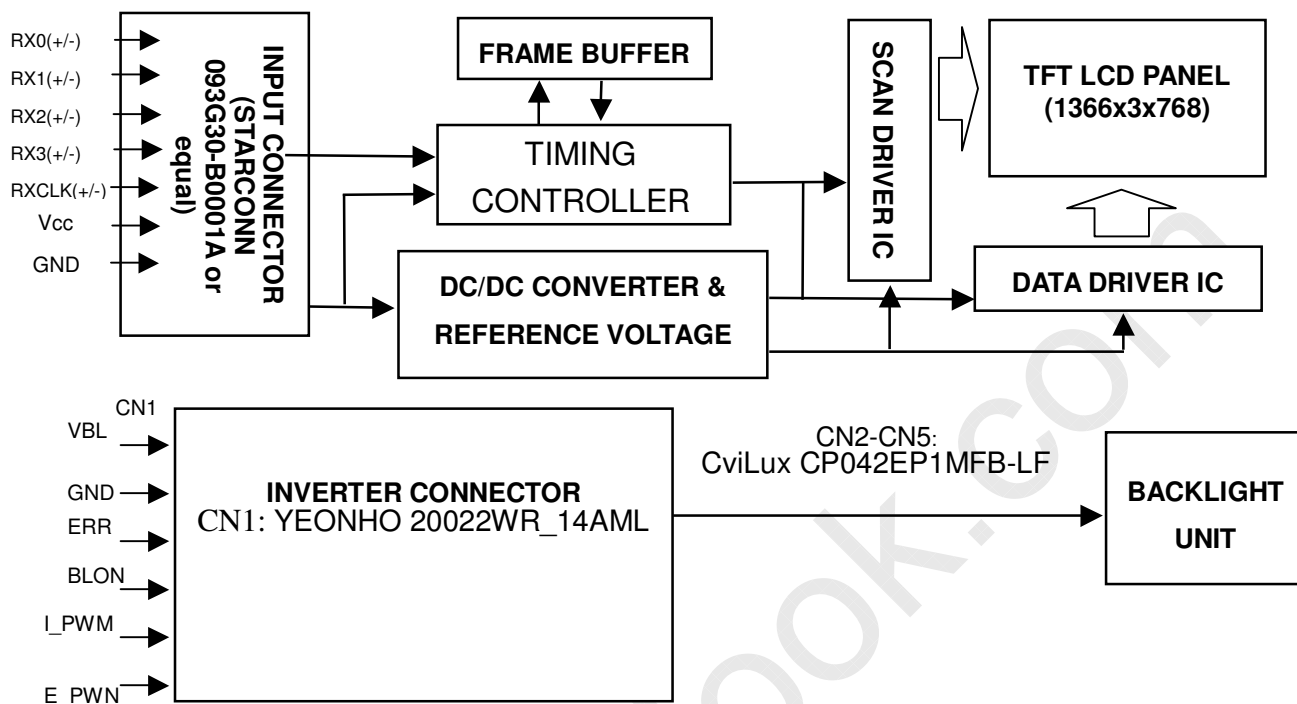

## 5. INTERFACE PIN CONNECTION

### 5.1 TFT LCD MODULE

#### CNF1 Connector Pin Assignment

Pin No.	Symbol	Description	Note
1	VCC	Power supply: +12V	
2	VCC	Power supply: +12V	
3	VCC	Power supply: +12V	
4	VCC	Power supply: +12V	
5	GND	Ground	
6	GND	Ground	
7	GND	Ground	
8	GND	Ground	
9	SELLVDS	Select LVDS data format	(2)
10	ODSEL	Overdrive Lookup Table Selection	(3)
11	GND	Ground	
12	RX0-	Negative transmission data of pixel 0	
13	RX0+	Positive transmission data of pixel 0	
14	GND	Ground	
15	RX1-	Negative transmission data of pixel 1	
16	RX1+	Positive transmission data of pixel 1	
17	GND	Ground	
18	RX2-	Negative transmission data of pixel 2	
19	RX2+	Positive transmission data of pixel 2	
20	GND	Ground	
21	RXCLK-	Negative of clock	
22	RXCLK+	Positive of clock	
23	GND	Ground	
24	RX3-	Negative transmission data of pixel 3	
25	RX3+	Positive transmission data of pixel 3	
26	GND	Ground	
27	NC	No connection	(4)
28	NC	No connection	(4)
29	GND	Ground	
30	GND	Ground	

Note (1) Connector type: STARCONN 093G30-B0001A or P-TWO 187053-30091 or compatible

Note (2) Ground or OPEN: VESA, High: JEIDA LVDS format

Please refer to 5.5 LVDS INTERFACE

Note (3) Overdrive lookup table selection. The Overdrive lookup table should be selected in accordance to the frame rate to optimize image quality.

ODSEL	Note
L or Open	Lookup table was optimized for 60 Hz frame rate.
H	Lookup table was optimized for 50 Hz frame rate.

Note (4) Reserved for internal use. Left it open.

## 5.2 BACKLIGHT UNIT

The pin configuration for the housing and leader wire is shown in the table below.

CN2-CN5 (Housing): Cvilux CP042ESFA00 or equivalent

Pin No.	Symbol	Description	Wire Color
1	HV	High Voltage	PINK
2	HV	High Voltage	WHITE

Note (1) The backlight interface housing for high voltage side is Cvilux CP042ESFA00 or equivalent. The mating header on inverter part number is Cvilux CP042EP1MFB-LF or equivalent

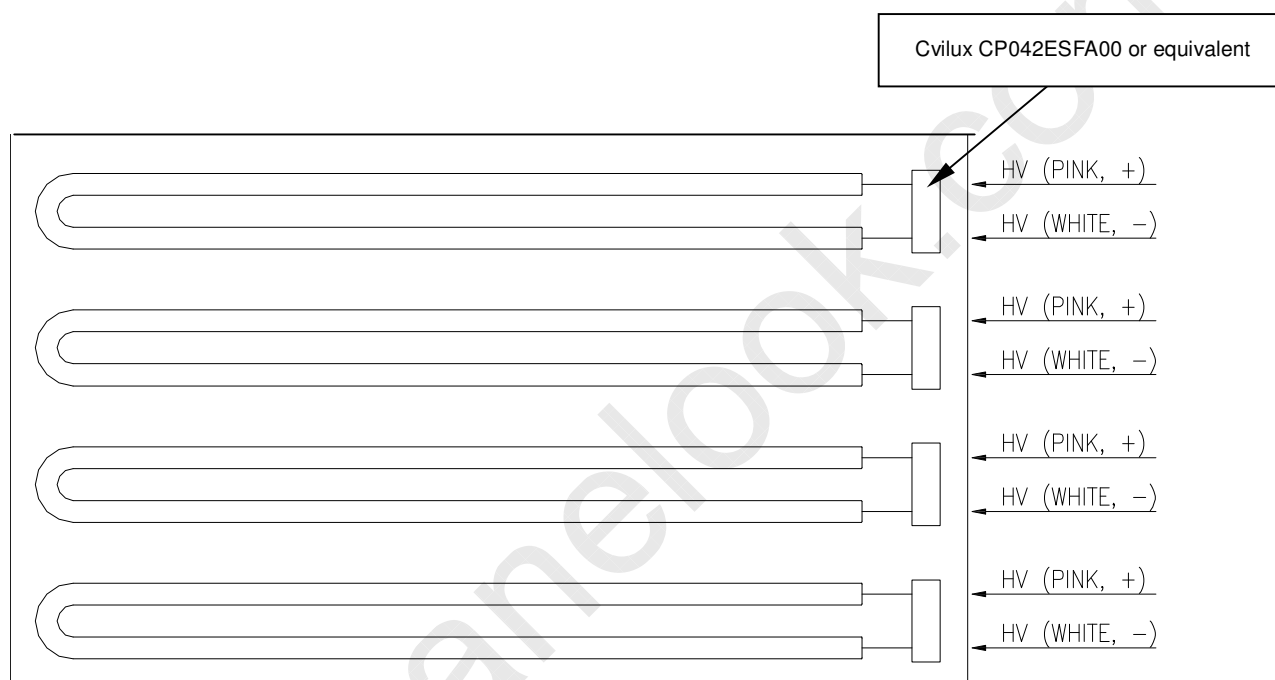



**5.3 INVERTER UNIT**

CN1(Header): YEONHO 20022WR\_14AML or equivalent

Pin No.	Symbol	Description
1	VBL	+24V Power input
2		
3		
4		
5		
6	GND	Ground
7		
8		
9		
10		
11	ERR	Normal (GND) Abnormal ( open collector)
12	BLON	Backlight on/off control
13	I_PWM	Internal PWM control signal
14	E_PWM	External PWM control signal

Notice:

Note (1) PIN 13:Internal PWM Control (Use Pin 13): Pin 14 must open.

Note (2) PIN 14:External PWM Control (Use Pin 14): Pin 13 must open.

Note (3) Pin 13(I\_PWM) and Pin 14(E\_PWM) can't open in same period.

CN2(Header): CviLux CP042EP1MFB-LF or equivalent

Pin No.	Symbol	Description
1	CCFL HOT	CCFL high voltage
2	CCFL HOT	CCFL high voltage

## 5.4 BLOCK DIAGRAM OF INTERFACE

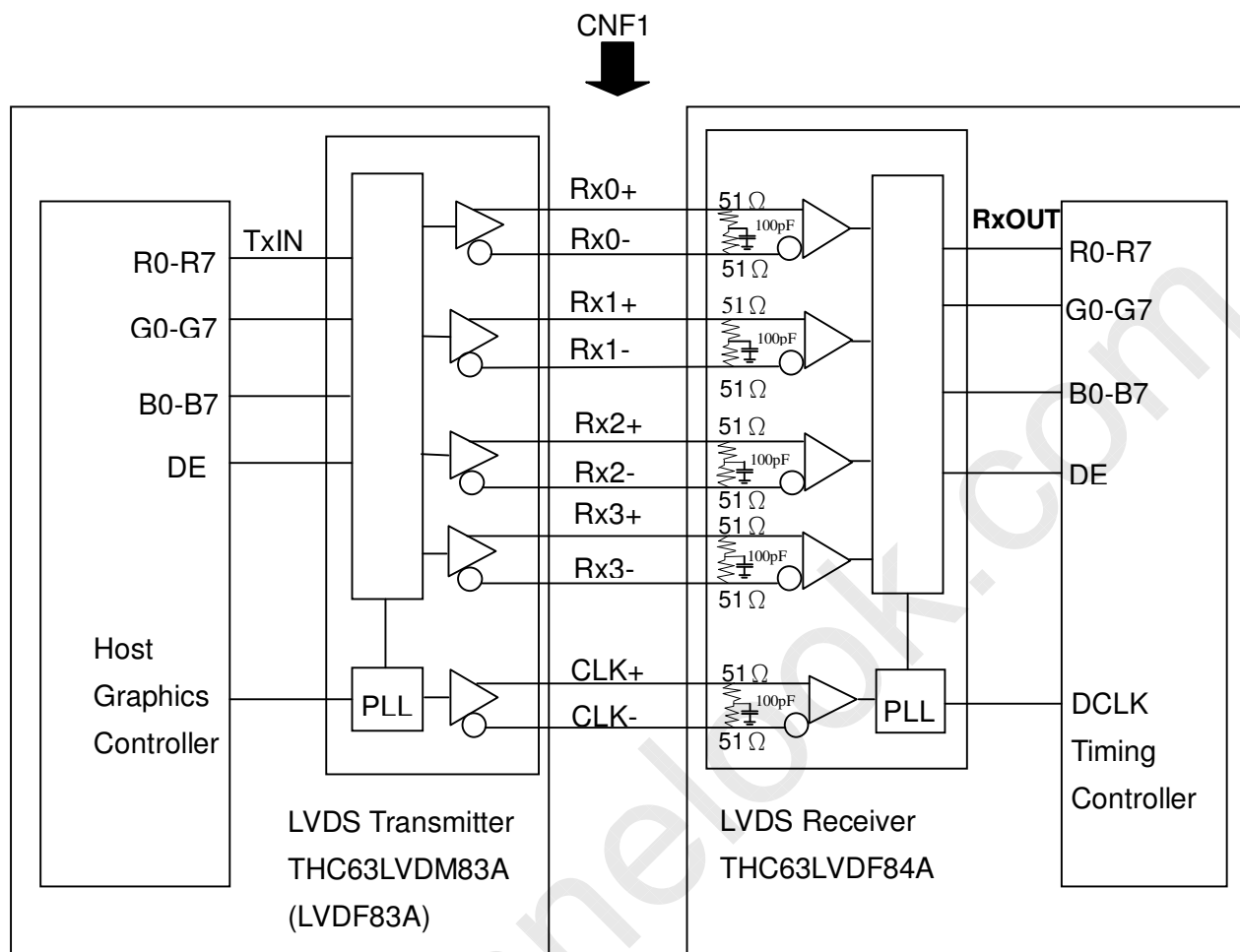

R0~R7 : Pixel R Data ,  
 G0~G7 : Pixel G Data ,  
 B0~B7 : Pixel B Data ,  
 DE : Data enable signal

Note (1) The system must have the transmitter to drive the module.

Note (2) LVDS cable impedance shall be 50 ohms per signal line or about 100 ohms per twist-pair line when it is used differentially.

## 5.5 LVDS INTERFACE

### SELLVDS = L or Open (VESA)

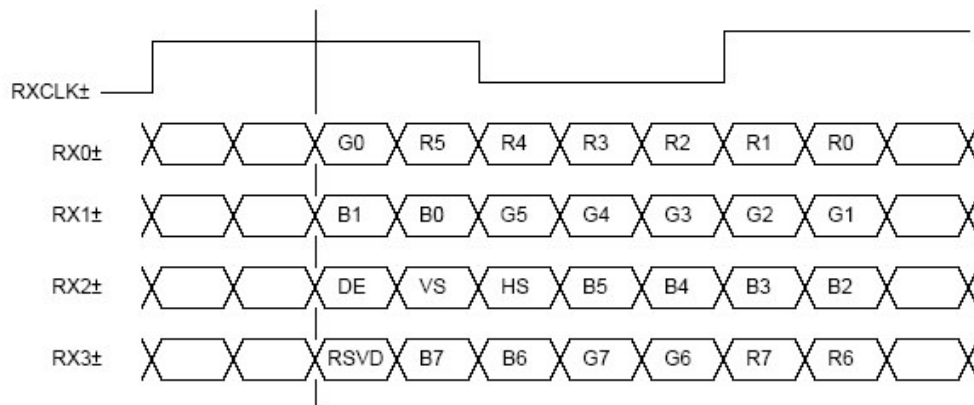

### SELLVDS = H (JEIDA)

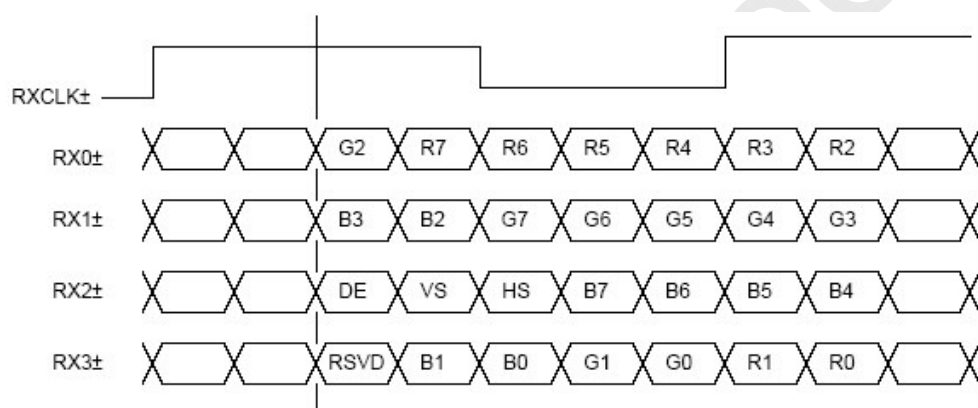

R0~R7: Pixel R Data (7; MSB, 0; LSB)

G0~G7: Pixel G Data (7; MSB, 0; LSB)

B0~B7: Pixel B Data (7; MSB, 0; LSB)

DE: Data enable signal

Notes(1) RSVD(reserved)pins on the transmitter shall be "H" or("L" or OPEN)



### 5.6 COLOR DATA INPUT ASSIGNMENT

The brightness of each primary color (red, green and blue) is based on the 8-bit gray scale data input for the color. The higher the binary input, the brighter the color. The table below provides the assignment of color versus data input.

Color		Data Signal																							
		Red								Green								Blue							
		R7	R6	R5	R4	R3	R2	R1	R0	G7	G6	G5	G4	G3	G2	G1	G0	B7	B6	B5	B4	B3	B2	B1	B0
Basic Colors	Black	0	0	0	0	0	0	0	0	0	0	0	0	0	0	0	0	0	0	0	0	0	0	0	
	Red	1	1	1	1	1	1	1	1	0	0	0	0	0	0	0	0	0	0	0	0	0	0	0	
	Green	0	0	0	0	0	0	0	0	1	1	1	1	1	1	1	1	0	0	0	0	0	0	0	
	Blue	0	0	0	0	0	0	0	0	0	0	0	0	0	0	0	1	1	1	1	1	1	1	1	
	Cyan	0	0	0	0	0	0	0	0	1	1	1	1	1	1	1	1	1	1	1	1	1	1	1	
	Magenta	1	1	1	1	1	1	1	1	0	0	0	0	0	0	0	0	1	1	1	1	1	1	1	
	Yellow	1	1	1	1	1	1	1	1	1	1	1	1	1	1	1	1	0	0	0	0	0	0	0	
	White	1	1	1	1	1	1	1	1	1	1	1	1	1	1	1	1	1	1	1	1	1	1	1	
Gray Scale Of Red	Red(0) / Dark	0	0	0	0	0	0	0	0	0	0	0	0	0	0	0	0	0	0	0	0	0	0		
	Red(1)	0	0	0	0	0	0	0	1	0	0	0	0	0	0	0	0	0	0	0	0	0	0		
	Red(2)	0	0	0	0	0	0	1	0	0	0	0	0	0	0	0	0	0	0	0	0	0	0		
	:	:	:	:	:	:	:	:	:	:	:	:	:	:	:	:	:	:	:	:	:	:	:		
	:	:	:	:	:	:	:	:	:	:	:	:	:	:	:	:	:	:	:	:	:	:	:		
	Red(253)	1	1	1	1	1	1	0	1	0	0	0	0	0	0	0	0	0	0	0	0	0	0		
	Red(254)	1	1	1	1	1	1	1	0	0	0	0	0	0	0	0	0	0	0	0	0	0	0		
	Red(255)	1	1	1	1	1	1	1	1	0	0	0	0	0	0	0	0	0	0	0	0	0	0		
Gray Scale Of Green	Green(0) / Dark	0	0	0	0	0	0	0	0	0	0	0	0	0	0	0	0	0	0	0	0	0	0		
	Green(1)	0	0	0	0	0	0	0	0	0	0	0	0	0	0	1	0	0	0	0	0	0	0		
	Green(2)	0	0	0	0	0	0	0	0	0	0	0	0	0	1	0	0	0	0	0	0	0	0		
	:	:	:	:	:	:	:	:	:	:	:	:	:	:	:	:	:	:	:	:	:	:	:		
	:	:	:	:	:	:	:	:	:	:	:	:	:	:	:	:	:	:	:	:	:	:	:		
	Green(253)	0	0	0	0	0	0	0	0	1	1	1	1	1	1	0	1	0	0	0	0	0	0		
	Green(254)	0	0	0	0	0	0	0	0	1	1	1	1	1	1	1	0	0	0	0	0	0	0		
	Green(255)	0	0	0	0	0	0	0	0	1	1	1	1	1	1	1	1	0	0	0	0	0	0		
Gray Scale Of Blue	Blue(0) / Dark	0	0	0	0	0	0	0	0	0	0	0	0	0	0	0	0	0	0	0	0	0	0		
	Blue(1)	0	0	0	0	0	0	0	0	0	0	0	0	0	0	0	0	0	0	0	0	0	1		
	Blue(2)	0	0	0	0	0	0	0	0	0	0	0	0	0	0	0	0	0	0	0	0	0	1		
	:	:	:	:	:	:	:	:	:	:	:	:	:	:	:	:	:	:	:	:	:	:	:		
	:	:	:	:	:	:	:	:	:	:	:	:	:	:	:	:	:	:	:	:	:	:	:		
	Blue(253)	0	0	0	0	0	0	0	0	0	0	0	0	0	0	0	1	1	1	1	1	1	0		
	Blue(254)	0	0	0	0	0	0	0	0	0	0	0	0	0	0	0	1	1	1	1	1	1	0		
	Blue(255)	0	0	0	0	0	0	0	0	0	0	0	0	0	0	0	1	1	1	1	1	1	1		

Note (1) 0: Low Level Voltage, 1: High Level Voltage

## 6. INTERFACE TIMING

### 6.1 INPUT SIGNAL TIMING SPECIFICATIONS

The input signal timing specifications are shown as the following table and timing diagram.

Signal	Item	Symbol	Min.	Typ.	Max.	Unit	Note
LVDS Receiver Clock	Frequency	1/Tc	60	76	82	MHZ	
	Input cycle to cycle jitter	Trcl	-	-	200	ps	
LVDS Receiver Data	Setup Time	Tlvsu	600	-	-	ps	
	Hold Time	Tlvhd	600	-	-	ps	
Vertical Active Display Term	Frame Rate	Fr5	47	50	53	Hz	(2)
		Fr6	57	60	63	Hz	
	Total	Tv	778	806	888	Th	Tv=Tvd+Tvb
	Display	Tvd	768	768	768	Th	-
	Blank	Tvb	10	38	120	Th	-
Horizontal Active Display Term	Total	Th	1442	1560	1936	Tc	Th=Thd+Thb
	Display	Thd	1366	1366	1366	Tc	-
	Blank	Thb	76	194	570	Tc	-

Note (1) Since this module is operated in DE only mode, Hsync and Vsync input signals should be set to low logic level. Otherwise, this module would operate abnormally.

(2) Please refer to 5.1 for detail information.

### INPUT SIGNAL TIMING DIAGRAM

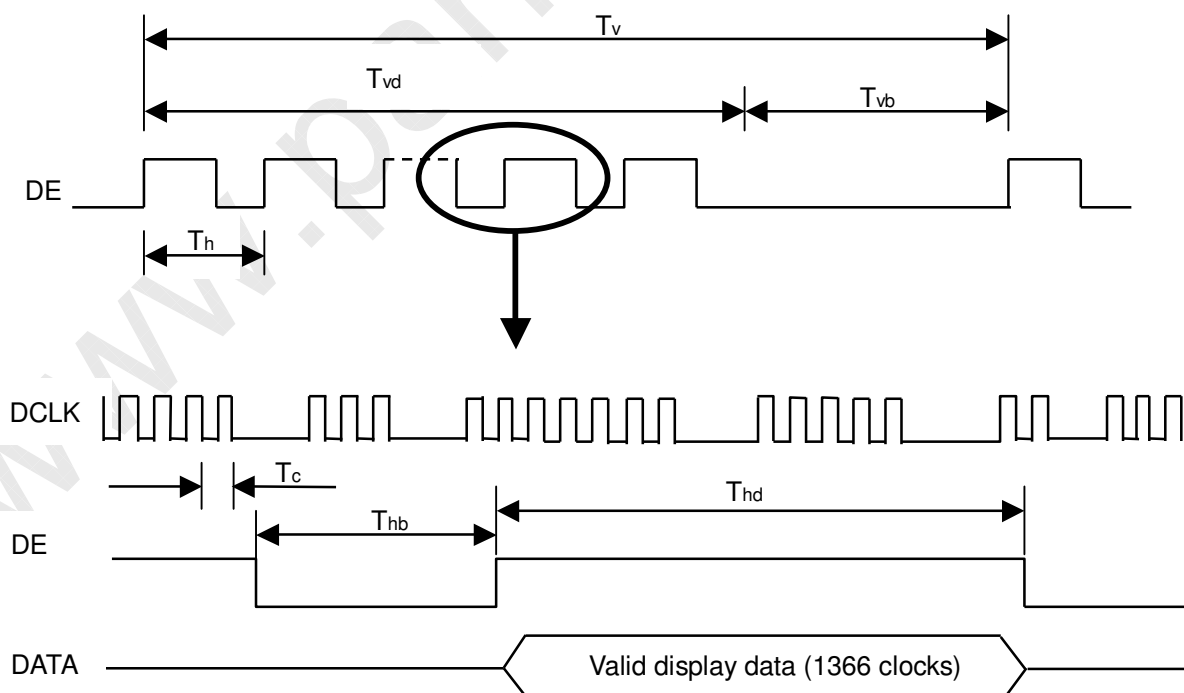

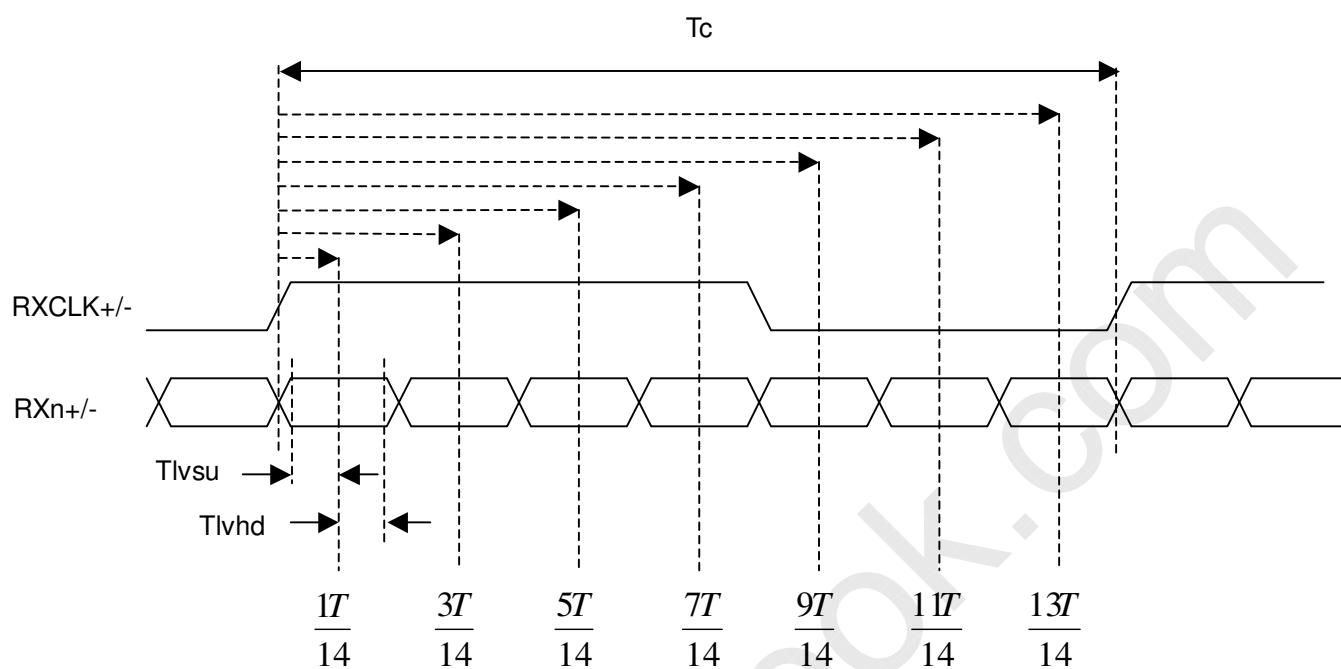
**LVDS RECEIVER INTERFACE TIMING DIAGRAM**

## 6.2 POWER ON/OFF SEQUENCE

To prevent a latch-up or DC operation of LCD module, the power on/off sequence should be as the diagram below.

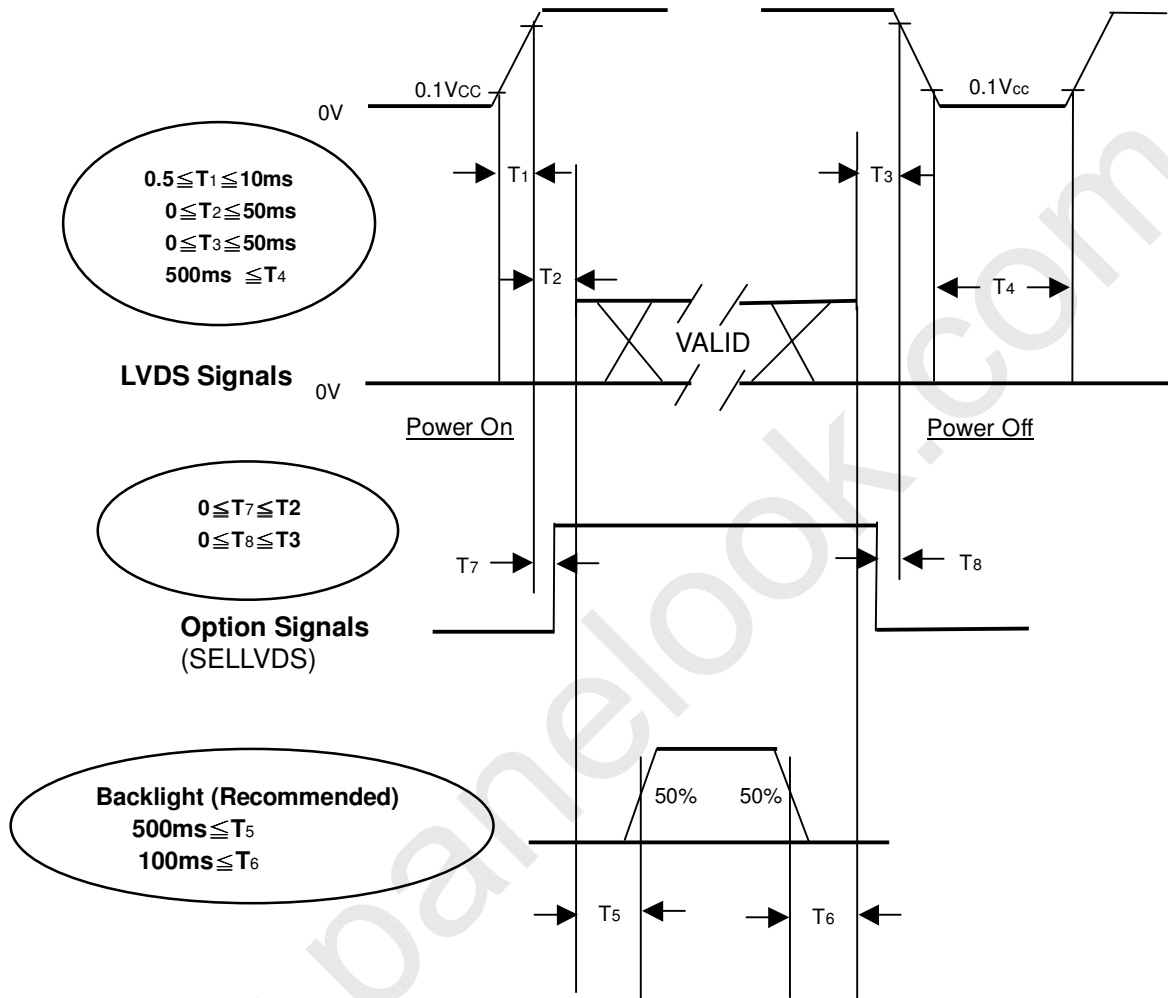

**Power ON/OFF Sequence**

Note (1) The supply voltage of the external system for the module input should follow the definition of Vcc.

Note (2) Apply the lamp voltage within the LCD operation range. When the backlight turns on before the LCD operation or the LCD turns off before the backlight turns off, the display may momentarily become abnormal screen.

Note (3) In case of Vcc is in off level, please keep the level of input signals on the low or high impedance. If  $T_2 < 0$ , that maybe cause electrical overstress failures.

Note (4) T4 should be measured after the module has been fully discharged between power off and on period.

Note (5) Interface signal shall not be kept at high impedance when the power is on.

## 7. OPTICAL CHARACTERISTICS

### 7.1 TEST CONDITIONS

Item	Symbol	Value	Unit
Ambient Temperature	Ta	25±2	°C
Ambient Humidity	Ha	50±10	%RH
Supply Voltage	V <sub>CC</sub>	12.0	V
Input Signal	According to typical value in "3. ELECTRICAL CHARACTERISTICS"		
Lamp Current	I <sub>L</sub>	10.5±0.5	mA
Oscillating Frequency (Inverter)	F <sub>w</sub>	63±3	KHz
Frame rate	Fr	60	Hz

### 7.2 OPTICAL SPECIFICATIONS

The relative measurement methods of optical characteristics are shown in 7.2. The following items should be measured under the test conditions described in 7.1 and stable environment shown in Note (6).

Item		Symbol	Condition	Min.	Typ.	Max.	Unit	Note	
Contrast Ratio		CR	$\theta_x=0^\circ, \theta_y=0^\circ$ Viewing Angle at Normal Direction	2500	3000	-	-	(2)	
Response Time		Gray to gray average		8.5	14	ms	(3)		
Center Luminance of White		L <sub>c</sub>		360	450	-	cd/m <sup>2</sup>	(4)	
White Variation		δW		-	-	1.3	-	(7)	
Cross Talk		CT		-	-	4.0	%	(5)	
Color Chromaticity	Red	R <sub>x</sub>		Typ -0.03	Typ +0.03	0.647	-	-	(6)
		R <sub>y</sub>				0.334			
	Green	G <sub>x</sub>				0.272			
		G <sub>y</sub>				0.596			
	Blue	B <sub>x</sub>				0.142			
		B <sub>y</sub>	0.068						
	White	W <sub>x</sub>	0.285						
W <sub>y</sub>		0.293							
Color Gamut		CG		72		%	NTSC		
Viewing Angle	Horizontal	θ <sub>x+</sub>	CR≥20	80	88	-	Deg.	(1)	
		θ <sub>x-</sub>		80	88	-			
	Vertical	θ <sub>y+</sub>		80	88	-			
		θ <sub>y-</sub>		80	88	-			



Note (1) Definition of Viewing Angle ( $\theta_x, \theta_y$ ):

Viewing angles are measured by EZ-Contrast 160R (Eldim)

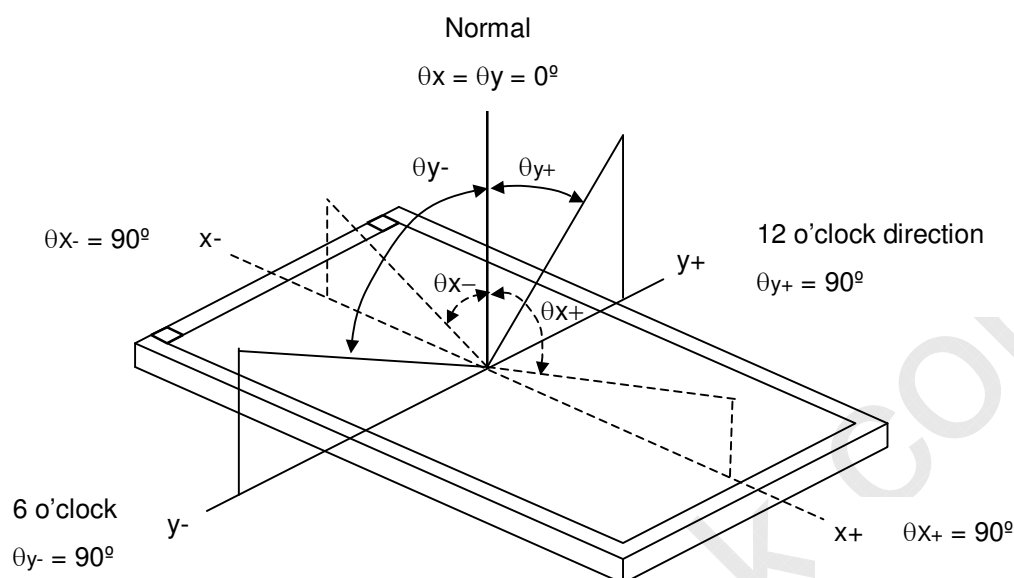

Note (2) Definition of Contrast Ratio (CR):

The contrast ratio can be calculated by the following expression.

$$\text{Contrast Ratio (CR)} = L_{255} / L_0$$

L255: Luminance of gray level 255

L 0: Luminance of gray level 0

CR = CR (5), where CR (X) is corresponding to the Contrast Ratio of the point X at the figure in Note (7).

Note (3) Definition of Gray to Gray Switching Time :

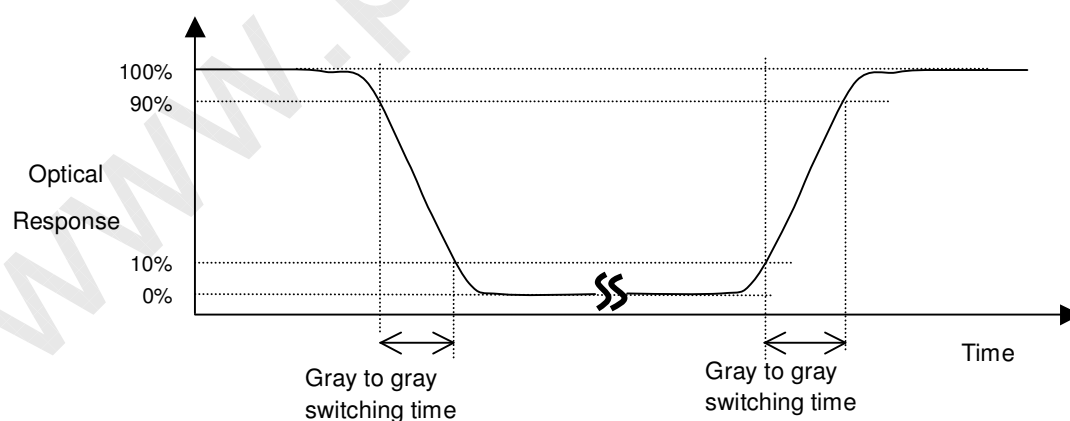

The driving signal means the signal of luminance 0%, 25%, 50%, 75%, 100%.

Gray to gray average time means the average switching time of luminance 0%, 25%, 50%, 75%, 100% to each other.

Note (4) Definition of Luminance of White ( $L_C$ ,  $L_{AVE}$ ):

Measure the luminance of gray level 255 at center point and 5 points

$$L_C = L(5)$$

$$L_{AVE} = [L(1) + L(2) + L(3) + L(4) + L(5)] / 5$$

where  $L(x)$  is corresponding to the luminance of the point  $X$  at the figure in Note (7).

Note (5) Definition of Cross Talk (CT):

$$CT = |Y_B - Y_A| / Y_A \times 100 (\%)$$

Where:

$Y_A$  = Luminance of measured location without gray level 0 pattern (cd/m<sup>2</sup>)

$Y_B$  = Luminance of measured location with gray level 0 pattern (cd/m<sup>2</sup>)

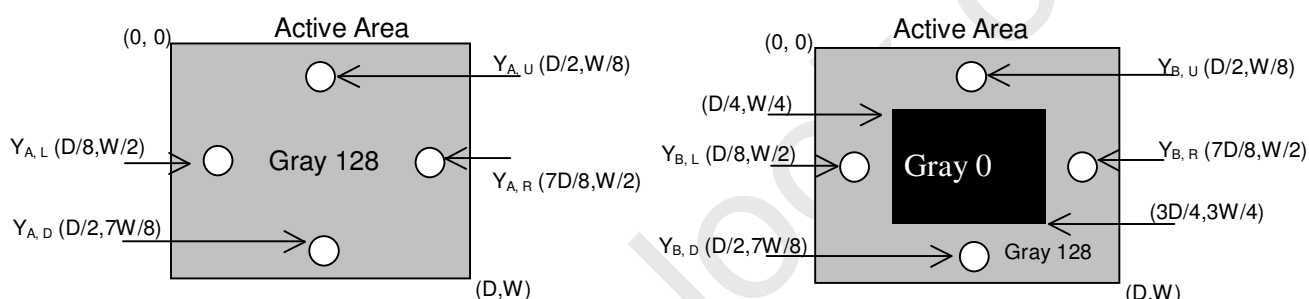

Note (6) Measurement Setup:

The LCD module should be stabilized at given temperature for 1 hour to avoid abrupt temperature change during measuring. In order to stabilize the luminance, the measurement should be executed after lighting Backlight for 1 hour in a windless room.

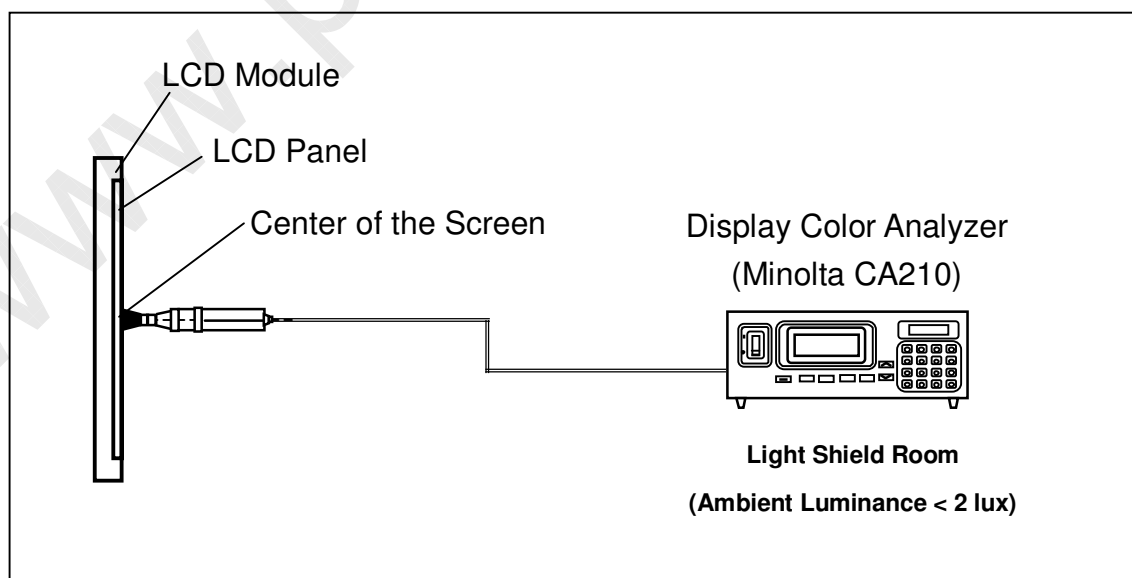

Note (7) Definition of White Variation ( $\delta W$ ):

Measure the luminance of gray level 255 at 5 points

$$\delta W = \text{Maximum [L (1), L (2), L (3), L (4), L (5)] / Minimum [L (1), L (2), L (3), L (4), L (5)]}$$

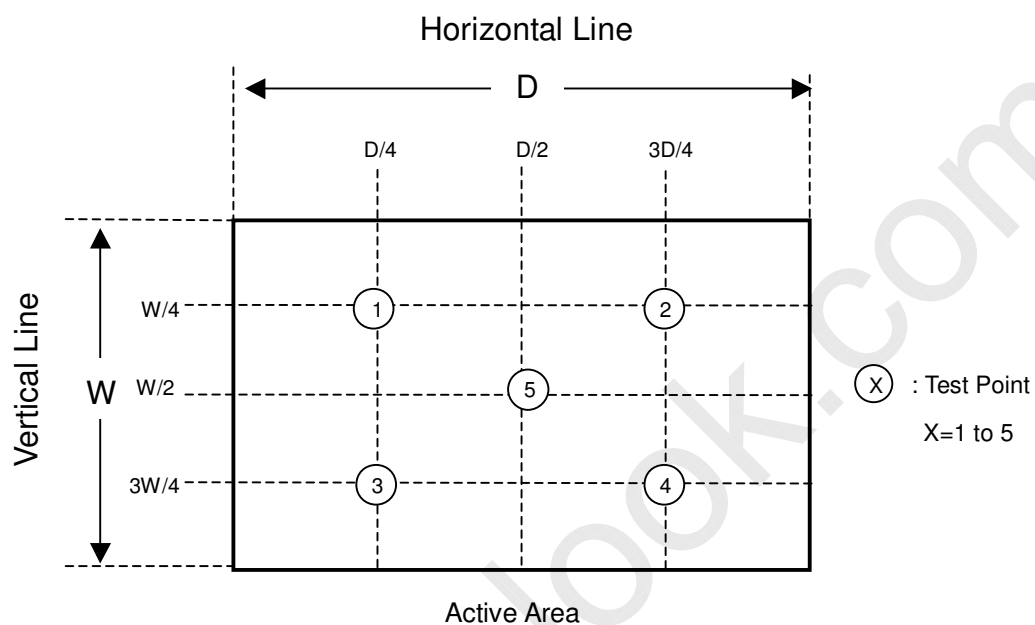

## 8. DEFINITION OF LABELS

### 8.1 CMO MODULE LABEL

The barcode nameplate is pasted on each module as illustration, and its definitions are as following explanation.

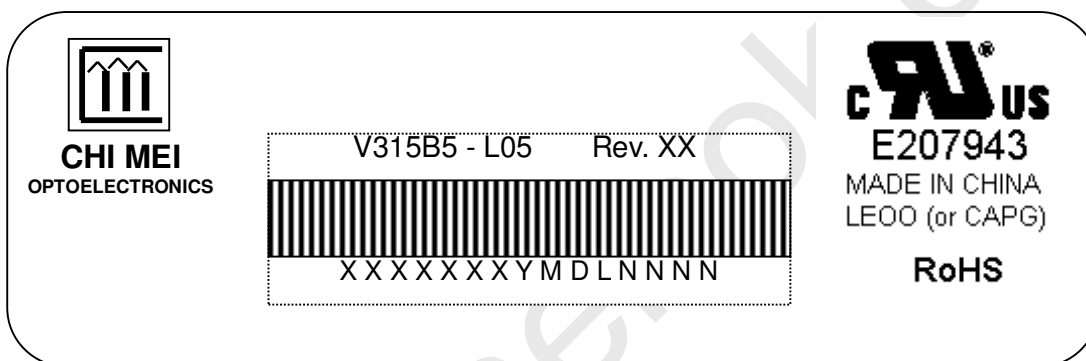
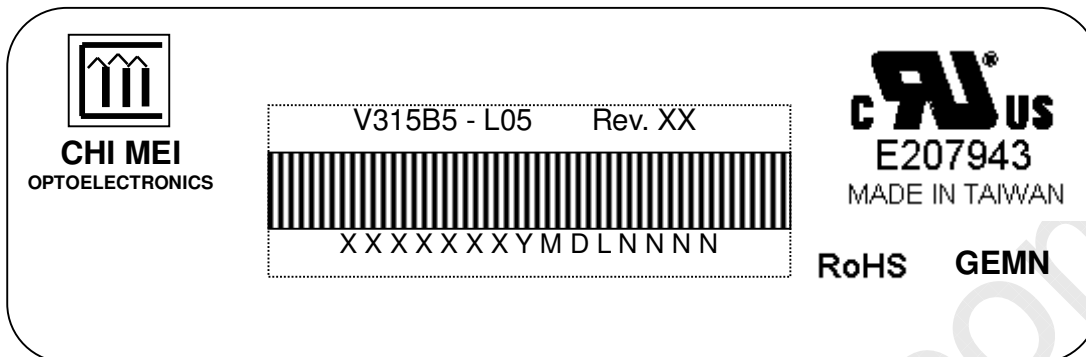

- (a) Model Name: V315B5-L05
- (b) Revision: Rev. XX, for example: A0, A1... B1, B2... or C1, C2...etc.
- (c) Serial ID: XXXXXXXXYMDLNNNN

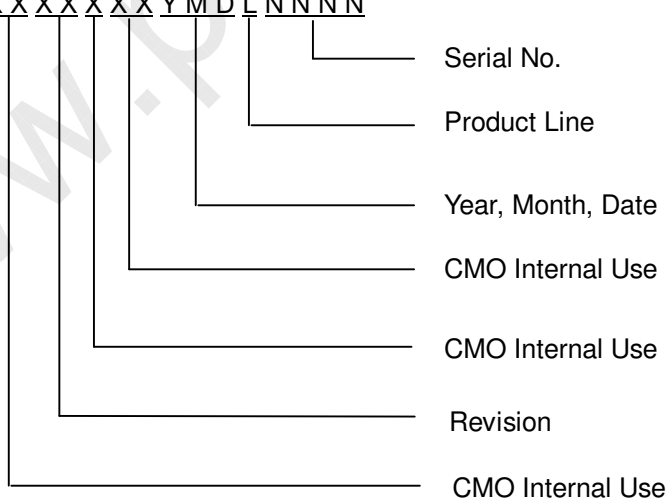

Serial ID includes the information as below:

- (a) Manufactured Date: Year: 0~9, for 2000~2009,  
Month: 1~9, A~C, for Jan. ~ Dec.  
Day: 1~9, A~Y, for 1<sup>st</sup> to 31<sup>st</sup>, exclude I ,O, and U.
- (b) Revision Code: Cover all the change
- (c) Serial No.: Manufacturing sequence of product
- (d) Product Line: 1 -> Line1, 2 -> Line 2, ...etc.

## 9. PACKAGING

### 9.1 PACKING SPECIFICATIONS

- (1) 5 LCD TV modules / 1 Box
- (2) Box dimensions : 826(L) X 376 (W) X 540 (H)
- (3) Weight : approximately 30Kg (5 modules per box)

### 9.2 PACKING METHOD

Figures 9-1 and 9-2 are the packing method

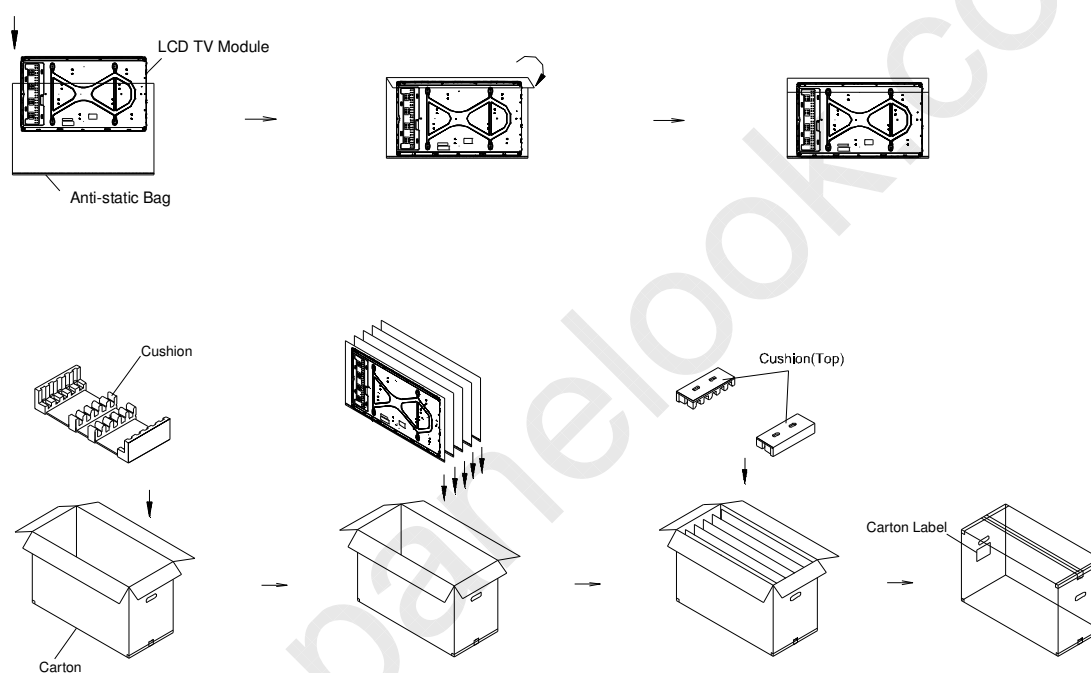
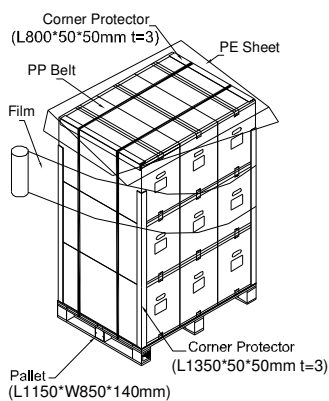
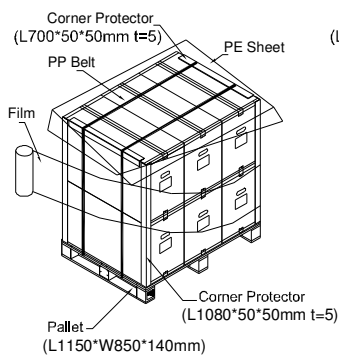

Figure.9-1 packing method

Sea / Land Transportation  
(40ft Container)  
Gross:285kg



Air Transportation  
Gross:195kg



Sea / Land Transportation  
(40ft HQ Container)  
Gross:390kg

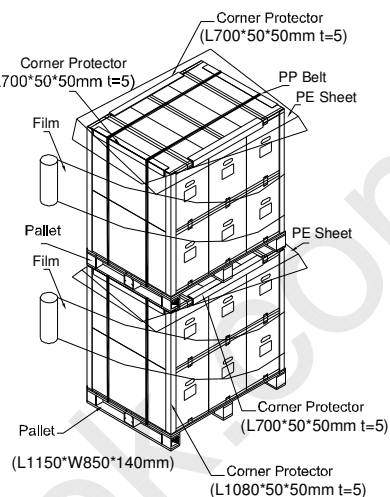

Figure.9-2 packing method

## 10. PRECAUTIONS

### 10.1 ASSEMBLY AND HANDLING PRECAUTIONS

- (1) Do not apply rough force such as bending or twisting to the module during assembly.
- (2) It is recommended to assemble or to install a module into the user's system in clean working areas. The dust and oil may cause electrical short or worsen the polarizer.
- (3) Do not apply pressure or impulse to the module to prevent the damage of LCD panel and backlight.
- (4) Always follow the correct power-on sequence when the LCD module is turned on. This can prevent the damage and latch-up of the CMOS LSI chips.
- (5) Do not plug in or pull out the I/F connector while the module is in operation.
- (6) Do not disassemble the module.
- (7) Use a soft dry cloth without chemicals for cleaning, because the surface of polarizer is very soft and easily scratched.
- (8) Moisture can easily penetrate into LCD module and may cause the damage during operation.
- (9) High temperature or humidity may deteriorate the performance of LCD module. Please store LCD modules in the specified storage conditions.
- (10) When ambient temperature is lower than 10°C, the display quality might be reduced. For example, the response time will become slow, and the starting voltage of CCFL will be higher than that of room temperature.

### 10.2 SAFETY PRECAUTIONS

- (1) The startup voltage of a backlight is over 1000 Volts. It may cause an electrical shock while assembling with the inverter. Do not disassemble the module or insert anything into the backlight unit.
- (2) If the liquid crystal material leaks from the panel, it should be kept away from the eyes or mouth. In case of contact with hands, skin or clothes, it has to be washed away thoroughly with soap.
- (3) After the module's end of life, it is not harmful in case of normal operation and storage.



**10.3 SAFETY STANDARDS**

## (1) SAFETY APPROVALS

Regulatory	Item	Standard
Information Technology equipment	UL	UL 60950-1: 2003 or UL 60950-1:2006
	cUL	CAN/CSA C22.2 No.60950-1-03 or CAN/CSA C22.2 No.60950-1-03: 2006
	CB	IEC 60950-1:2001 or IEC 60950-1:2005
Audio/Video Apparatus	UL	UL 60065: 2003 or UL 60065:2006
	cUL	CAN/CSA C22.2 No.60065-03 or CAN/CSA C22.2 No.60065-03: 2006
	CB	IEC 60065:2001 or IEC 60065:2006

**10.4 EMC**

(1) FCC class B part15

(2) CISPR20

Note(1)CMO product can support to meet FCC class B part15 and CISPR20 standard

### 11. MECHANICAL CHARACTERISTICS

