

TFT LCD Approval Specification

MODEL NO.: V315H1 – L01

Customer: _____

Approved by: _____

Note:

Approved By	TV Head Division	
	LY Chen	

Reviewed By	QA Dept.	Product Development Div.
	Kc_Ko	WT Lin

Prepared By	LCD TV Marketing and Product Management Div.	
	WY Li	Vincent Chou

- CONTENTS -

REVISION HISTORY	-----	3
1. GENERAL DESCRIPTION	-----	4
1.1 OVERVIEW		
1.2 FEATURES		
1.3 APPLICATION		
1.4 GENERAL SPECIFICATIONS		
1.5 MECHANICAL SPECIFICATIONS		
2. ABSOLUTE MAXIMUM RATINGS	-----	5
2.1 ABSOLUTE RATINGS OF ENVIRONMENT		
2.2 PACKAGE STORAGE		
2.3 ELECTRICAL ABSOLUTE RATINGS		
2.3.1 TFT LCD MODULE		
2.3.2 BACKLIGHT UNIT		
3. ELECTRICAL CHARACTERISTICS	-----	7
3.1 TFT LCD MODULE		
3.2 BACKLIGHT INVERTER UNIT		
3.2.1 CCFL(Cold Cathode Fluorescent Lamp) CHARACTERISTICS		
4. BLOCK DIAGRAM	-----	9
4.1 TFT LCD MODULE		
5. INTERFACE PIN CONNECTION	-----	10
5.1 TFT LCD MODULE		
5.2 BACKLIGHT UNIT		
5.3 BLOCK DIAGRAM OF INTERFACE		
5.4 LVDS INTERFACE		
5.5 COLOR DATA INPUT ASSIGNMENT		
6. INTERFACE TIMING	-----	17
6.1 INPUT SIGNAL TIMING SPECIFICATIONS		
6.2 POWER ON/OFF SEQUENCE		
7. OPTICAL CHARACTERISTICS	-----	20
7.1 TEST CONDITIONS		
7.2 OPTICAL SPECIFICATIONS		
8. DEFINITION OF LABELS	-----	24
8.1 CMO MODULE LABEL		
9. PACKAGING	-----	25
9.1 PACKING SPECIFICATIONS		
9.2 PACKING METHOD		
10. PRECAUTIONS	-----	27
10.1 ASSEMBLY AND HANDLING PRECAUTIONS		
10.2 SAFETY PRECAUTIONS		
10.3 SAFETY STANDARDS		
11. MECHANICAL CHARACTERISTICS	-----	28

REVISION HISTORY

Version	Date	Page (New)	Section	Description
Ver 2.0	Dec 05,08'	All	All	Approval Specification was first issued.

1. GENERAL DESCRIPTION

1.1 OVERVIEW

V315H1- L01 is a 31.5" TFT Liquid Crystal Display module with 4U-type CCFL Backlight unit and 2-LVDS interface. This module supports 1920 x 1080 HDTV format and can display 16.7M colors (8-bit/color). The inverter module for backlight is built-in.

1.2 FEATURES

- High brightness (500 nits)
- Ultra-high contrast ratio (4500:1)
- Fast response time (gray to gray average 6.5ms)
- High color saturation NTSC 72%
- Ultra wide viewing angle : 176(H)/176(V) (CR \geq 20) with Super MVA technology
- DE (Data Enable) only mode
- Full HDTV (1920 x 1080 pixels) resolution, true HDTV format
- LVDS (Low Voltage Differential Signaling) interface
- Color reproduction (nature color)
- Low color shift function

1.3 APPLICATION

- TFT LCD TVs
- Multi-Media Display

1.4 GENERAL SPECIFICATIONS

Item	Specification	Unit	Note
Active Area	698.4(H) x 392.85 (V)	mm	
Bezel Opening Area	703.8 (H) x 398.4 (V)	mm	
Driver Element	a-si TFT active matrix	-	
Pixel Number	1920 x R.G.B. x 1080	pixel	
Pixel Pitch (Sub Pixel)	0.12125 (H) x 0.36375 (V)	mm	
Pixel Arrangement	RGB vertical stripe	-	
Display Colors	16.7M	color	
Display Operation Mode	Transmissive mode / Normally black	-	
Surface Treatment	Anti-Glare coating (Haze 11%), Hard coating (3H)	-	

1.5 MECHANICAL SPECIFICATIONS

Item	Min.	Typ.	Max.	Unit	Note	
Module Size	Horizontal(H)	759	760	761	mm	
	Vertical(V)	449	450	451	mm	
	Depth(D)	46.5	47.5	48.5	mm	To PCB cover
	Depth(D)	31.5	32.5	33.5	mm	To Rear
Weight	-	5270		g		

Note (1) Please refer to the attached drawings for more information of front and back outline dimensions.

2. ABSOLUTE MAXIMUM RATINGS

2.1 ABSOLUTE RATINGS OF ENVIRONMENT

Item	Symbol	Value		Unit	Note
		Min.	Max.		
Storage Temperature	T _{ST}	-20	+60	°C	(1)
Operating Ambient Temperature	T _{OP}	0	+50	°C	(1), (2)
Shock (Non-Operating)	S _{NOF}	-	50	G	(3), (5)
Vibration (Non-Operating)	V _{NOF}	-	1.0	G	(4), (5)

Note (1) Temperature and relative humidity range is shown in the figure below.

(a) 90 %RH Max. ($T_a \leq 40$ °C).

(b) Wet-bulb temperature should be 39 °C Max. ($T_a > 40$ °C).

(c) No condensation.

Note (2) The maximum operating temperature is based on the test condition that the surface temperature of display area is less than or equal to 65 °C with LCD module alone in a temperature controlled chamber. Thermal management should be considered in final product design to prevent the surface temperature of display area from being over 65 °C. The range of operating temperature may degrade in case of improper thermal management in final product design.

Note (3) 11 ms, half sine wave, 1 time for $\pm X$, $\pm Y$, $\pm Z$.

Note (4) 10 ~ 200 Hz, 10 min, 1 time each X, Y, Z.

Note (5) At testing Vibration and Shock, the fixture in holding the module has to be hard and rigid enough so that the module would not be twisted or bent by the fixture.

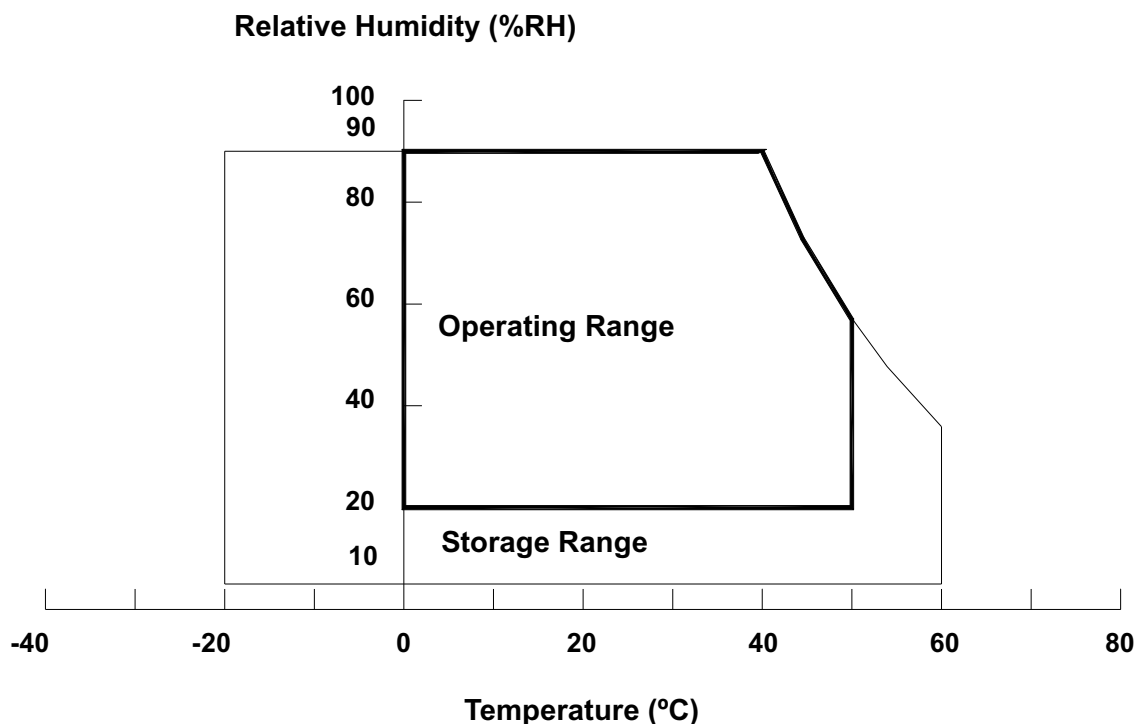

2.2 Package storage

When storing modules as spares for a long time, the following precaution is necessary.

- (a) Do not leave the module in high temperature, and high humidity for a long time. It is highly recommended to store the module with temperature from 0 to 35°C at normal humidity without condensation.
- (b) The module shall be stored in dark place. Do not store the TFT-LCD module in direct sunlight or fluorescent light.

2.3 ELECTRICAL ABSOLUTE RATINGS

2.3.1 TFT LCD MODULE

Item	Symbol	Value		Unit	Note
		Min.	Max.		
Power Supply Voltage	V_{CC}	-0.3	13.5	V	(1)
Logic Input Voltage	V_{IN}	-0.3	3.6	V	

2.3.2 BACKLIGHT UNIT

Item	Symbol	Value		Unit	Note
		Min.	Max.		
Lamp Voltage	V_W	—	3000	V_{RMS}	
Power Supply Voltage	V_{BL}	0	30	V	(1)
Control Signal Level	—	-0.3	7	V	(1), (3)

Note (1) Permanent damage to the device may occur if maximum values are exceeded. Functional operation should be restricted to the conditions described under normal operating conditions.

Note (2) No moisture condensation or freezing.

3. ELECTRICAL CHARACTERISTICS

3.1 TFT LCD MODULE

 $T_a = 25 \pm 2 \text{ }^\circ\text{C}$

Parameter	Symbol	Value			Unit	Note	
		Min.	Typ.	Max.			
Power Supply Voltage	V_{CC}	10.8	12	13.2	V	(1)	
Rush Current	I_{RUSH}	-	-	4.6	A	(2)	
Power Supply Current	White	-	1.0	1.2	A	(3)	
	Black	-	0.6	-	A		
	Vertical Stripe	-	0.9	-	A		
LVDS Interface	Differential Input High Threshold Voltage	V_{LVTH}	-	-	+100	mV	
	Differential Input Low Threshold Voltage	V_{LVTL}	-100	-	-	mV	
	Common Input Voltage	V_{LVC}	1.125	1.25	1.375	V	
	Terminating Resistor	R_T	-	100	-	ohm	
CMOS interface	Input High Threshold Voltage	V_{IH}	2.7	-	3.3	V	
	Input Low Threshold Voltage	V_{IL}	0	-	0.7	V	

Note (1) The module should be always operated within the above ranges.

Note (2) Measurement condition:

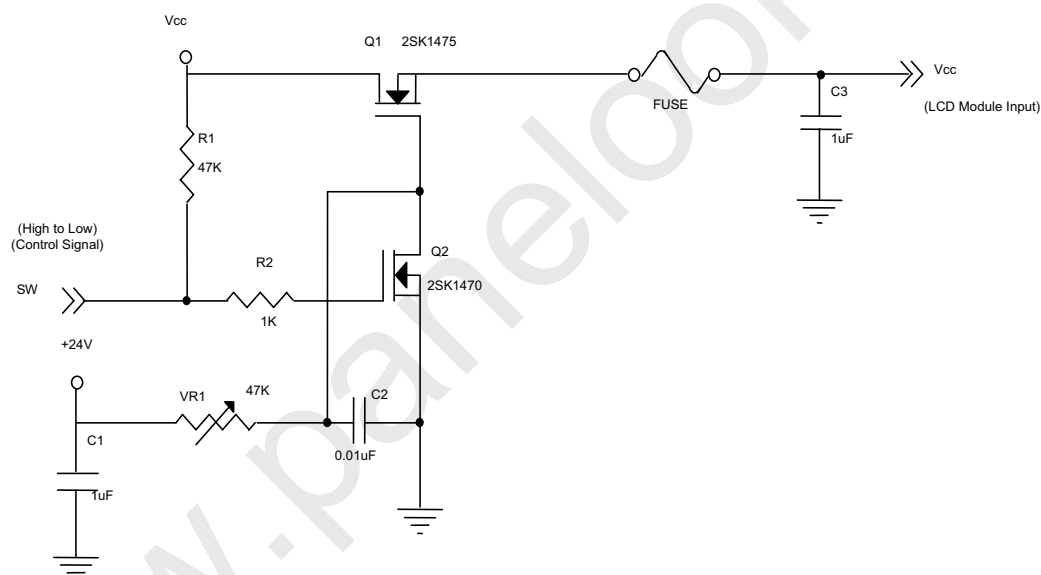

Vcc rising time is 470us

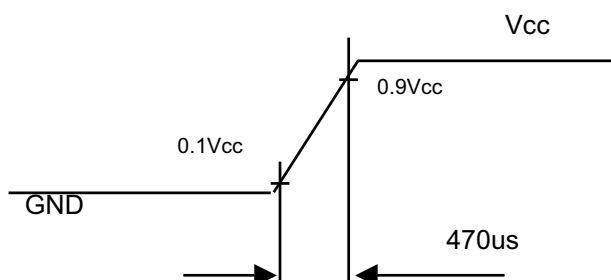

Note (3) The specified power supply current is under the conditions at $V_{cc} = 12V$, $T_a = 25 \pm 2 \text{ }^\circ\text{C}$, $f_v = 60 \text{ Hz}$, whereas a power dissipation check pattern below is displayed.

a. White Pattern

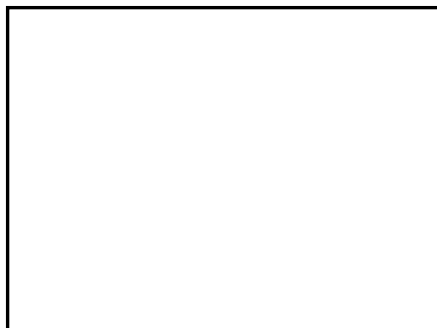

Active Area

b. Black Pattern



Active Area

c. Vertical Stripe Pattern

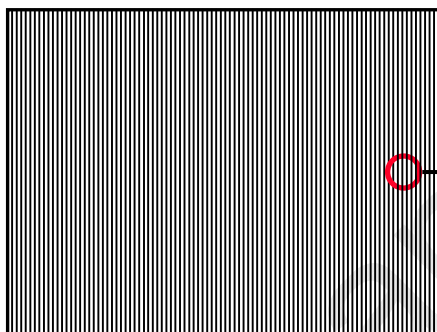

Active Area

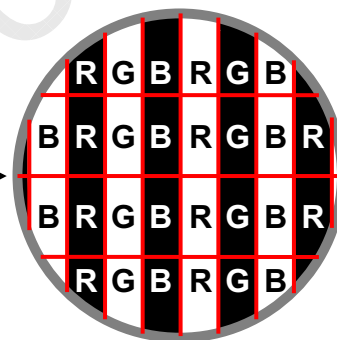

3.2 BACKLIGHT UNIT

3.2.1 CCFL (Cold Cathode Fluorescent Lamp) CHARACTERISTICS ($T_a = 25 \pm 2 \text{ }^\circ\text{C}$)

Parameter	Symbol	Value			Unit	Note
		Min.	Typ.	Max.		
Lamp Voltage	V_W	-	1510	-	V_{RMS}	$I_L = 12.3\text{mA}$
Lamp Current	I_L	11.6	12.3	13.0	mA_{RMS}	
Lamp Starting Voltage	V_S	-	-	2700	V_{RMS}	(2), $T_a = 0 \text{ }^\circ\text{C}$
		-	-	2290	V_{RMS}	(2), $T_a = 25 \text{ }^\circ\text{C}$
Operating Frequency	F_O	40	-	70	KHZ	(3)
Lamp Life Time	L_{BL}	50,000		-	Hrs	(4)

Note (1) Lamp current is measured by utilizing high frequency current meters.

Note (2) The lamp starting voltage V_S should be applied to the lamp for more than 1 second under starting up duration. Otherwise the lamp could not be lighted on completed.

Note (3) The lamp frequency may produce interference with horizontal synchronous frequency of the display input signals, and it may result in line flow on the display. In order to avoid interference, the lamp frequency should be detached from the horizontal synchronous frequency and its harmonics as far as possible.

Note (4) The life time of a lamp is defined as when the brightness is larger than 50% of its original value and the effective discharge length is longer than 80% of its original length (Effective discharge length is defined as an area that has equal to or more than 70% brightness compared to the brightness at the center point of lamp.) as the time in which it continues to operate under the condition at $T_a = 25 \pm 2$ °C and $I_L = 11.8 \sim 12.8 \text{ mA}_{\text{RMS}}$.

4. BLOCK DIAGRAM

4.1 TFT LCD MODULE

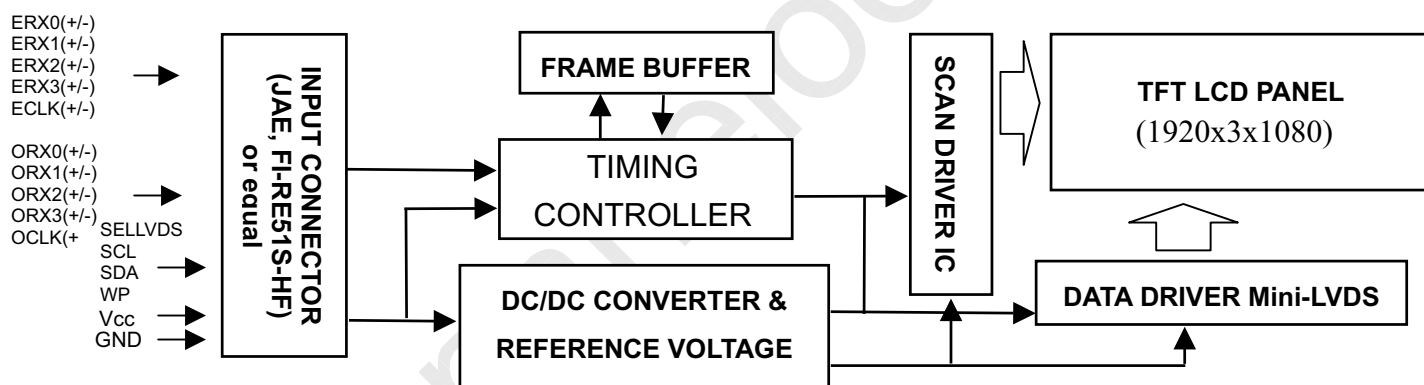

5. INTERFACE PIN CONNECTION

5.1 TFT LCD MODULE

CNF1 Connector Pin Assignment

Pin	Name	Description	Note
1	VCC	+12V power supply	
2	VCC	+12V power supply	
3	VCC	+12V power supply	
4	VCC	+12V power supply	
5	VCC	+12V power supply	
6	GND	Ground	
7	GND	Ground	
8	GND	Ground	
9	GND	Ground	
10	ORX0-	Odd pixel Negative LVDS differential data input. Channel 0	
11	ORX0+	Odd pixel Positive LVDS differential data input. Channel 0	
12	ORX1-	Odd pixel Negative LVDS differential data input. Channel 1	
13	ORX1+	Odd pixel Positive LVDS differential data input. Channel 1	
14	ORX2-	Odd pixel Negative LVDS differential data input. Channel 2	
15	ORX2+	Odd pixel Positive LVDS differential data input. Channel 2	
16	GND	Ground	
17	OCLK-	Odd pixel Negative LVDS differential clock input.	
18	OCLK+	Odd pixel Positive LVDS differential clock input.	
19	GND	Ground	
20	ORX3-	Odd pixel Negative LVDS differential data input. Channel 3	
21	ORX3+	Odd pixel Positive LVDS differential data input. Channel 3	
22	N.C.	No Connection	(2)
23	N.C.	No Connection	
24	GND	Ground	
25	ERX0-	Even pixel, Negative LVDS differential data input. Channel 0	
26	ERX0+	Even pixel, Positive LVDS differential data input. Channel 0	
27	ERX1-	Even pixel, Negative LVDS differential data input. Channel 1	
28	ERX1+	Even pixel, Positive LVDS differential data input. Channel 1	
29	ERX2-	Even pixel, Negative LVDS differential data input. Channel 2	
30	ERX2+	Even pixel, Positive LVDS differential data input. Channel 2	
31	GND	Ground	
32	ECLK-	Even pixel, Negative LVDS differential clock input	
33	ECLK+	Even pixel, Positive LVDS differential clock input.	
34	GND	Ground	
35	ERX3-	Even pixel, Negative LVDS differential data input. Channel 3	
36	ERX3+	Even pixel, Positive LVDS differential data input. Channel 3	
37	N.C.	No Connection	(2)
38	N.C.	No Connection	
39	GND	Ground	
40	SCL	EEPROM Serial Clock (SCL)	
41	N.C.	No Connection	(2)
42	N.C.	No Connection	(2)
43	WP.	EEPROM Write Protection (WP)	

44	SDA	EEPROM Serial Data (SDA)	
45	SELLVDS	LVDS Data Format Selection	(3)
46	N.C.	No Connection	(2)
47	N.C.	No Connection	
48	N.C.	No Connection	
49	N.C.	No Connection	(1)
50	N.C.	No Connection	
51	N.C.	No Connection	

Note (1) Connector part no.: (JAE)FI-RE51S-HF or equivalent

Note (2) HIGH or OPEN : VESA, LOW : JEIDA LVDS format

Please refer to 5.5 LVDS INTERFACE

Note (3) Reserved for internal use. Left it open.

5.2 BACKLIGHT UNIT

The backlight interface for high voltage side is Yeoho 90050GS-32DLQ or equivalent

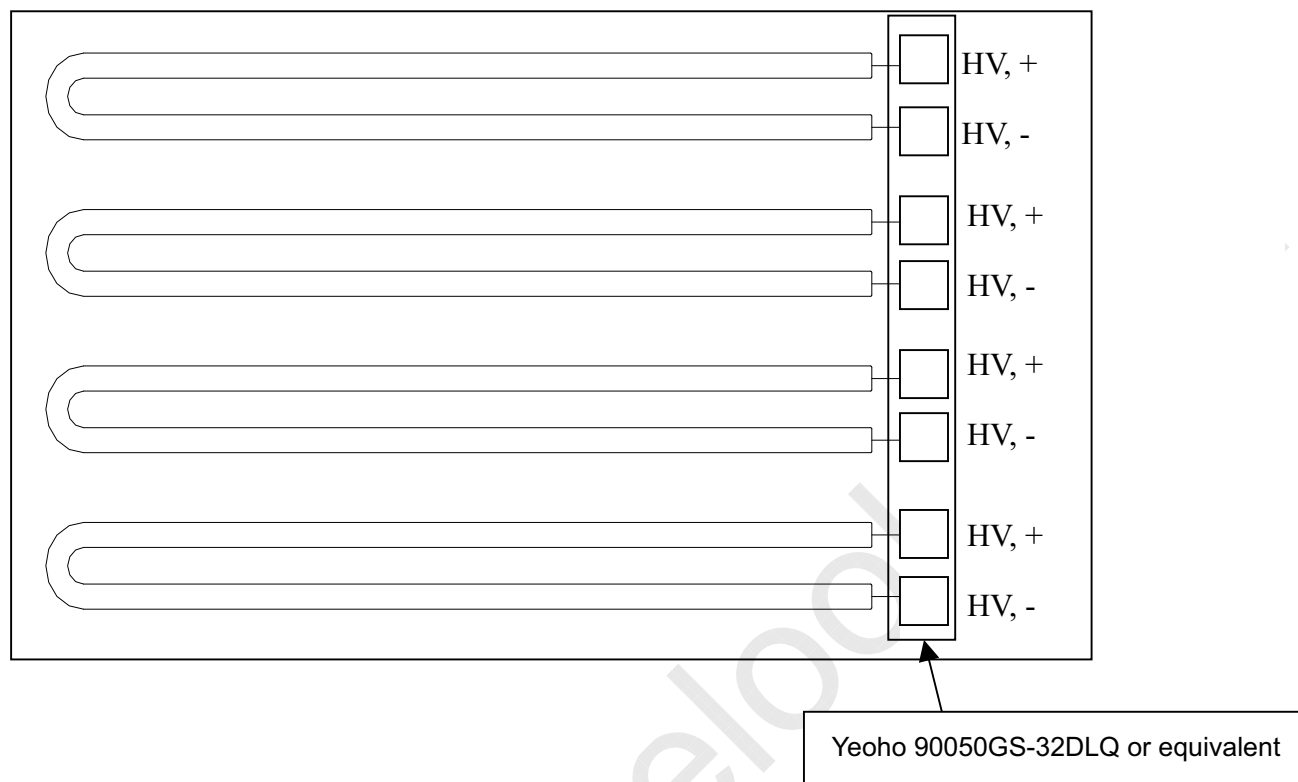

5.3 BLOCK DIAGRAM OF INTERFACE

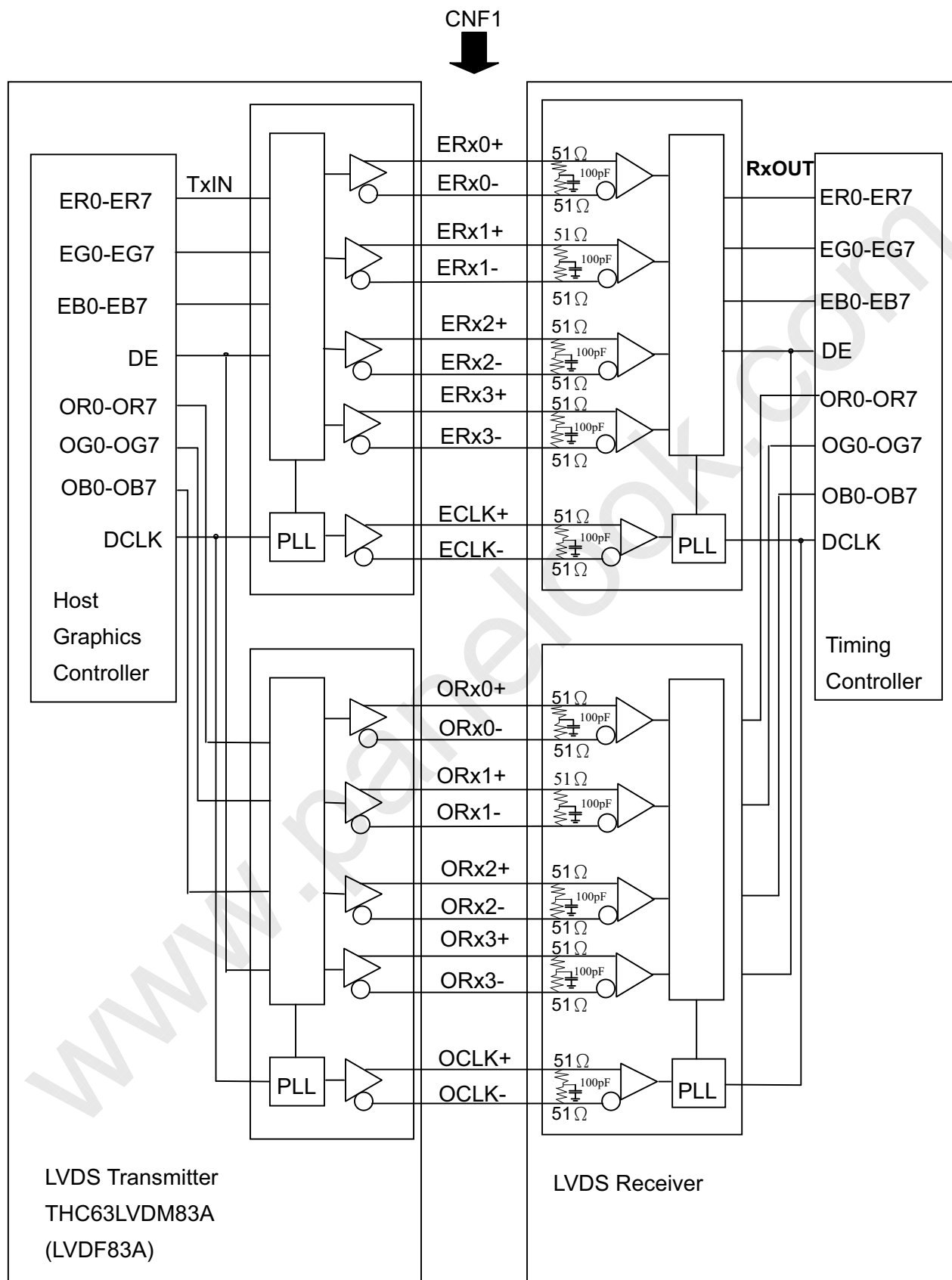

ER0~ER7 : Even pixel R data

EG0~EG7 : Even pixel G data

EB0~EB7 : Even pixel B data

OR0~OR7: Odd pixel R data

OG0~OG7: Odd pixel G data

OB0~OB7 : Odd pixel B data

DE : Data enable signal

DCLK : Data clock signal

Notes:

- (1) The system must have the transmitter to drive the module.
- (2) LVDS cable impedance shall be 50 ohms per signal line or about 100 ohms per twist-pair line when it is used differentially.
- (3) Two pixel data send into the module for every clock cycle. The first pixel of the frame is odd pixel and the second pixel is even pixel.

5.4 LVDS INTERFACE

JEDIA Format : SELLVDS=L

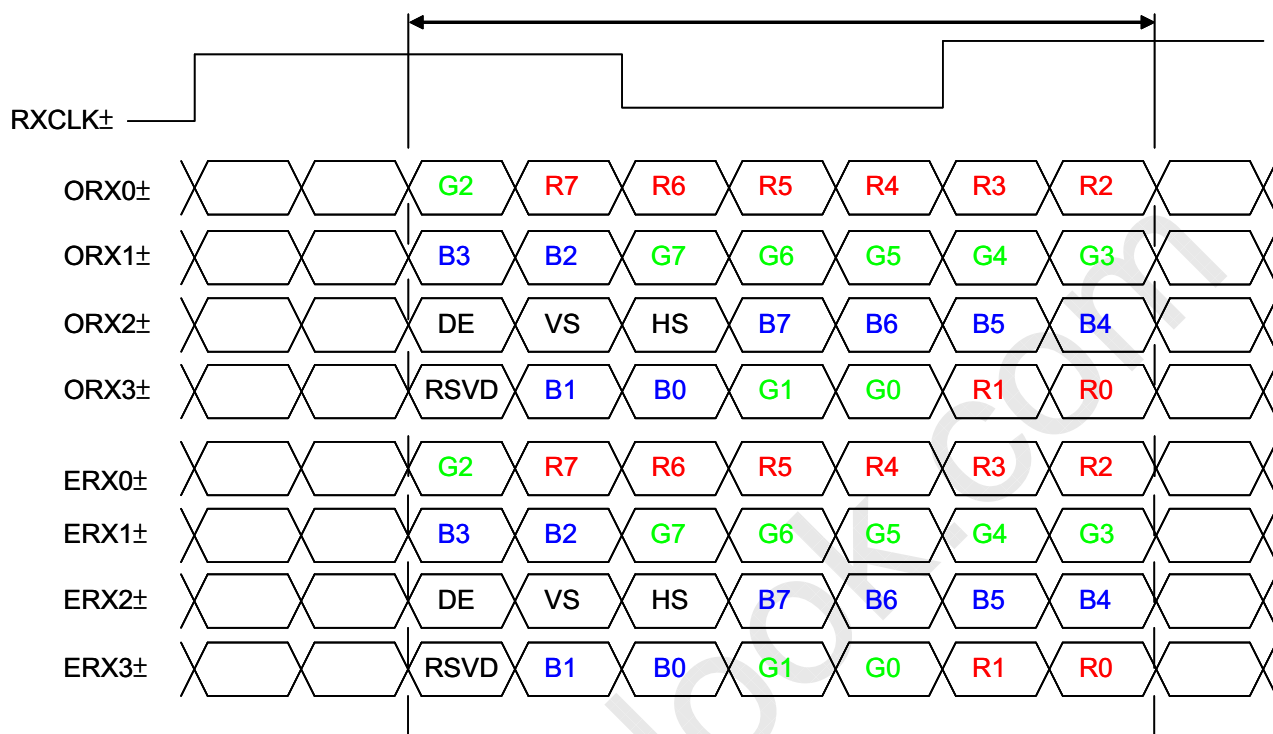

JEDIA Format : SELLVDS=H or OPEN

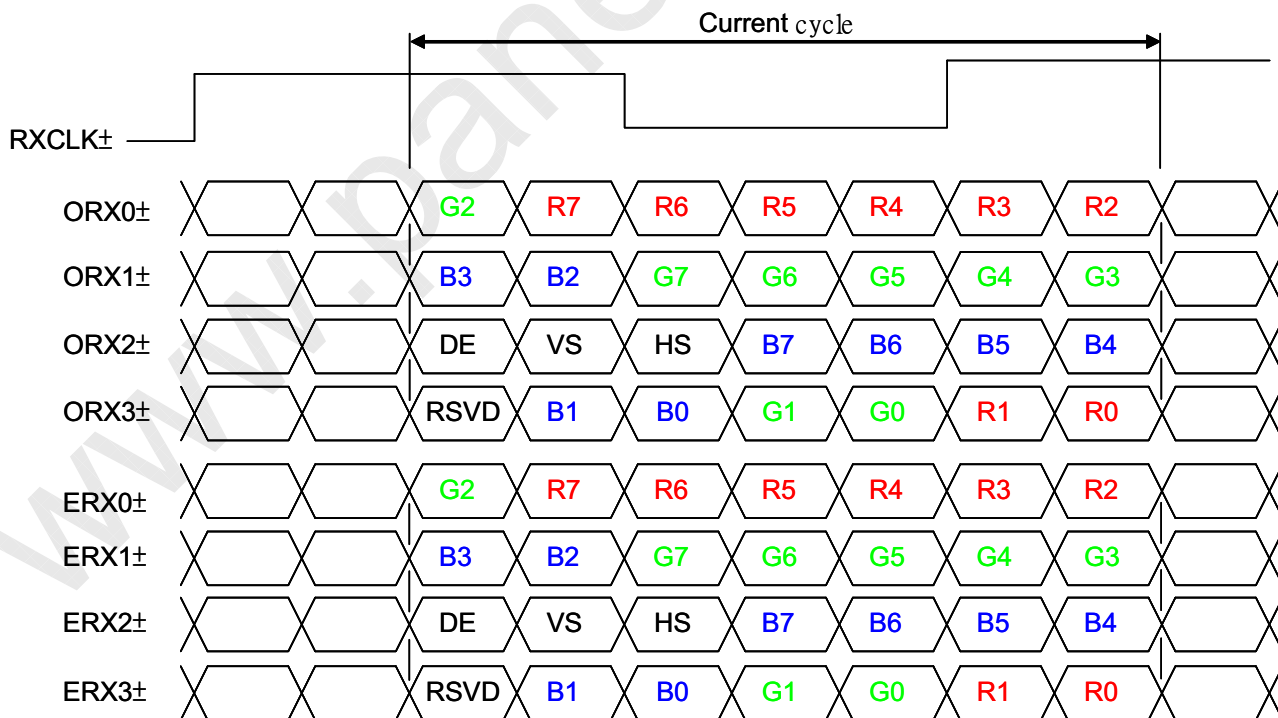



5.5 COLOR DATA INPUT ASSIGNMENT

The brightness of each primary color (red, green and blue) is based on the 8-bit gray scale data input for the color. The higher the binary input, the brighter the color. The table below provides the assignment of color versus data input.

Color		Data Signal																							
		Red								Green								Blue							
		R7	R6	R5	R4	R3	R2	R1	R0	G7	G6	G5	G4	G3	G2	G1	G0	B7	B6	B5	B4	B3	B2	B1	B0
Basic Colors	Black	0	0	0	0	0	0	0	0	0	0	0	0	0	0	0	0	0	0	0	0	0	0	0	0
	Red	1	1	1	1	1	1	1	1	0	0	0	0	0	0	0	0	0	0	0	0	0	0	0	0
	Green	0	0	0	0	0	0	0	0	1	1	1	1	1	1	1	1	0	0	0	0	0	0	0	0
	Blue	0	0	0	0	0	0	0	0	0	0	0	0	0	0	0	0	1	1	1	1	1	1	1	1
	Cyan	0	0	0	0	0	0	0	0	1	1	1	1	1	1	1	1	1	1	1	1	1	1	1	1
	Magenta	1	1	1	1	1	1	1	1	0	0	0	0	0	0	0	0	1	1	1	1	1	1	1	1
	Yellow	1	1	1	1	1	1	1	1	1	1	1	1	1	1	1	1	0	0	0	0	0	0	0	0
	White	1	1	1	1	1	1	1	1	1	1	1	1	1	1	1	1	1	1	1	1	1	1	1	1
Gray Scale Of Red	Red (0) / Dark	0	0	0	0	0	0	0	0	0	0	0	0	0	0	0	0	0	0	0	0	0	0	0	0
	Red (1)	0	0	0	0	0	0	0	1	0	0	0	0	0	0	0	0	0	0	0	0	0	0	0	0
	Red (2)	0	0	0	0	0	0	1	0	0	0	0	0	0	0	0	0	0	0	0	0	0	0	0	0
	:	:	:	:	:	:	:	:	:	:	:	:	:	:	:	:	:	:	:	:	:	:	:	:	:
	:	:	:	:	:	:	:	:	:	:	:	:	:	:	:	:	:	:	:	:	:	:	:	:	:
	Red (253)	1	1	1	1	1	1	0	1	0	0	0	0	0	0	0	0	0	0	0	0	0	0	0	0
	Red (254)	1	1	1	1	1	1	1	0	0	0	0	0	0	0	0	0	0	0	0	0	0	0	0	0
	Red (255)	1	1	1	1	1	1	1	1	0	0	0	0	0	0	0	0	0	0	0	0	0	0	0	0
Gray Scale Of Green	Green (0) / Dark	0	0	0	0	0	0	0	0	0	0	0	0	0	0	0	0	0	0	0	0	0	0	0	0
	Green (1)	0	0	0	0	0	0	0	0	0	0	0	0	0	0	1	0	0	0	0	0	0	0	0	0
	Green (2)	0	0	0	0	0	0	0	0	0	0	0	0	0	1	0	0	0	0	0	0	0	0	0	0
	:	:	:	:	:	:	:	:	:	:	:	:	:	:	:	:	:	:	:	:	:	:	:	:	:
	:	:	:	:	:	:	:	:	:	:	:	:	:	:	:	:	:	:	:	:	:	:	:	:	:
	Green (253)	0	0	0	0	0	0	0	0	1	1	1	1	1	1	0	1	0	0	0	0	0	0	0	0
	Green (254)	0	0	0	0	0	0	0	0	1	1	1	1	1	1	1	0	0	0	0	0	0	0	0	0
	Green (255)	0	0	0	0	0	0	0	0	1	1	1	1	1	1	1	1	0	0	0	0	0	0	0	0
Gray Scale Of Blue	Blue (0) / Dark	0	0	0	0	0	0	0	0	0	0	0	0	0	0	0	0	0	0	0	0	0	0	0	0
	Blue (1)	0	0	0	0	0	0	0	0	0	0	0	0	0	0	0	0	0	0	0	0	0	0	0	1
	Blue (2)	0	0	0	0	0	0	0	0	0	0	0	0	0	0	0	0	0	0	0	0	0	0	1	0
	:	:	:	:	:	:	:	:	:	:	:	:	:	:	:	:	:	:	:	:	:	:	:	:	:
	:	:	:	:	:	:	:	:	:	:	:	:	:	:	:	:	:	:	:	:	:	:	:	:	:
	Blue (253)	0	0	0	0	0	0	0	0	0	0	0	0	0	0	0	0	1	1	1	1	1	1	0	1

Blue (254)	0	0	0	0	0	0	0	0	0	0	0	0	0	0	0	0	0	1	1	1	1	1	1	1	1	0
Blue (255)	0	0	0	0	0	0	0	0	0	0	0	0	0	0	0	0	0	0	1	1	1	1	1	1	1	1

Note (1) 0: Low Level Voltage, 1: High Level Voltage

6. INTERFACE TIMING

6.1 INPUT SIGNAL TIMING SPECIFICATIONS

The input signal timing specifications are shown as the following table and timing diagram.

The input signal timing specifications are shown as the following table and timing diagram.

Signal	Item	Symbol	Min.	Typ.	Max.	Unit	Note
LVDS Receiver Clock	Frequency	1/Tc	(60)	74	(80)	MHz	-
	Input cycle to cycle jitter	Trcl	-	-	200	ps	-
LVDS Receiver Data	Setup Time	Tlvsu	600	-	-	ps	-
	Hold Time	Tlvhd	600	-	-	ps	-
Vertical Active Display Term	Frame Rate	Fr ₆	57	60	63	Hz	(1)
	Total	Tv	1115	1125	1410	Th	Tv=Tvd+Tvb
	Display	Tvd	1080	1080	1080	Th	-
	Blank	Tvb	35	45	330	Th	-
Horizontal Active Display Term	Total	Th	1050	1100	1325	Tc	Th=Thd+Thb
	Display	Thd	960	960	960	Tc	-
	Blank	Thb	90	140	365	Tc	-

Note (1) LVDS clock should not over 80MHz even if H-total or V-total is in SPEC. and the frequency follows the equation below:

$$\text{LVDS CLK} = \text{Frame rate} * \text{H-total} * \text{V-total}.$$

Note (2) The timing diagram show the one channel LVDS signal timing required at the input of the LVDS transmitter. It's a two channel LVDS signal input for this model.

INPUT SIGNAL TIMING DIAGRAM

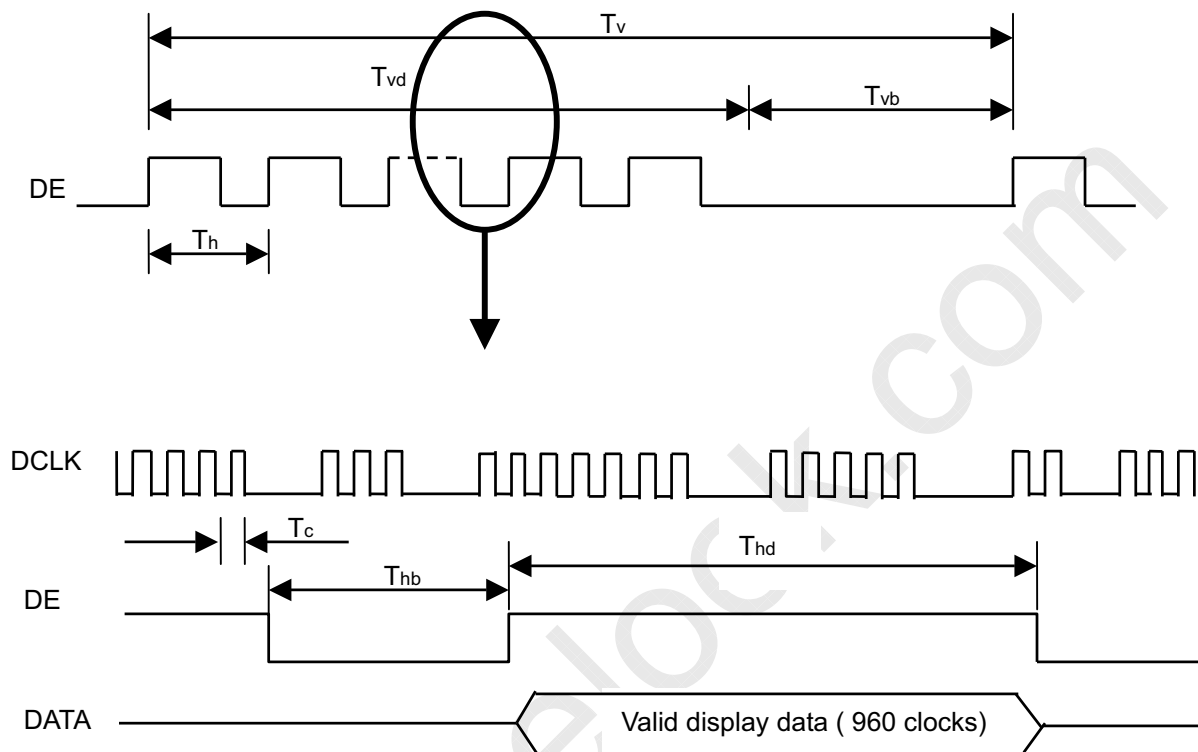

LVDS RECEIVER INTERFACE TIMING DIAGRAM

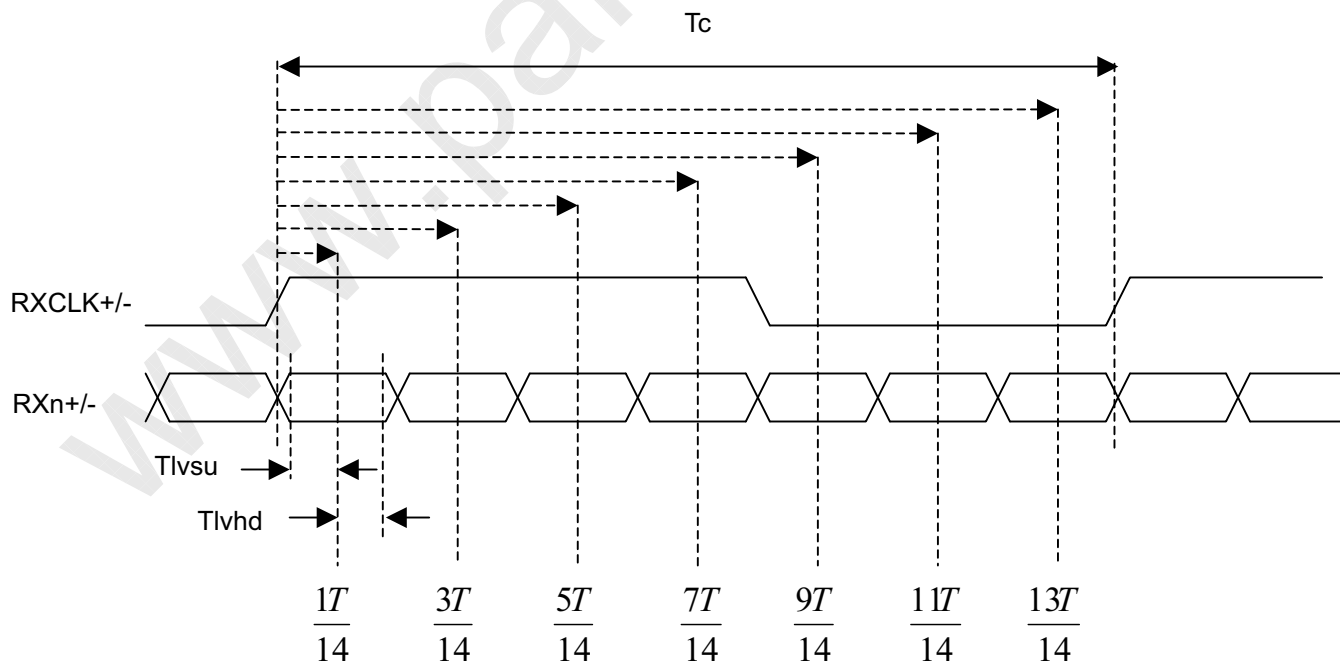

6.2 POWER ON/OFF SEQUENCE

To prevent a latch-up or DC operation of LCD module, the power on/off sequence should be as the diagram below.

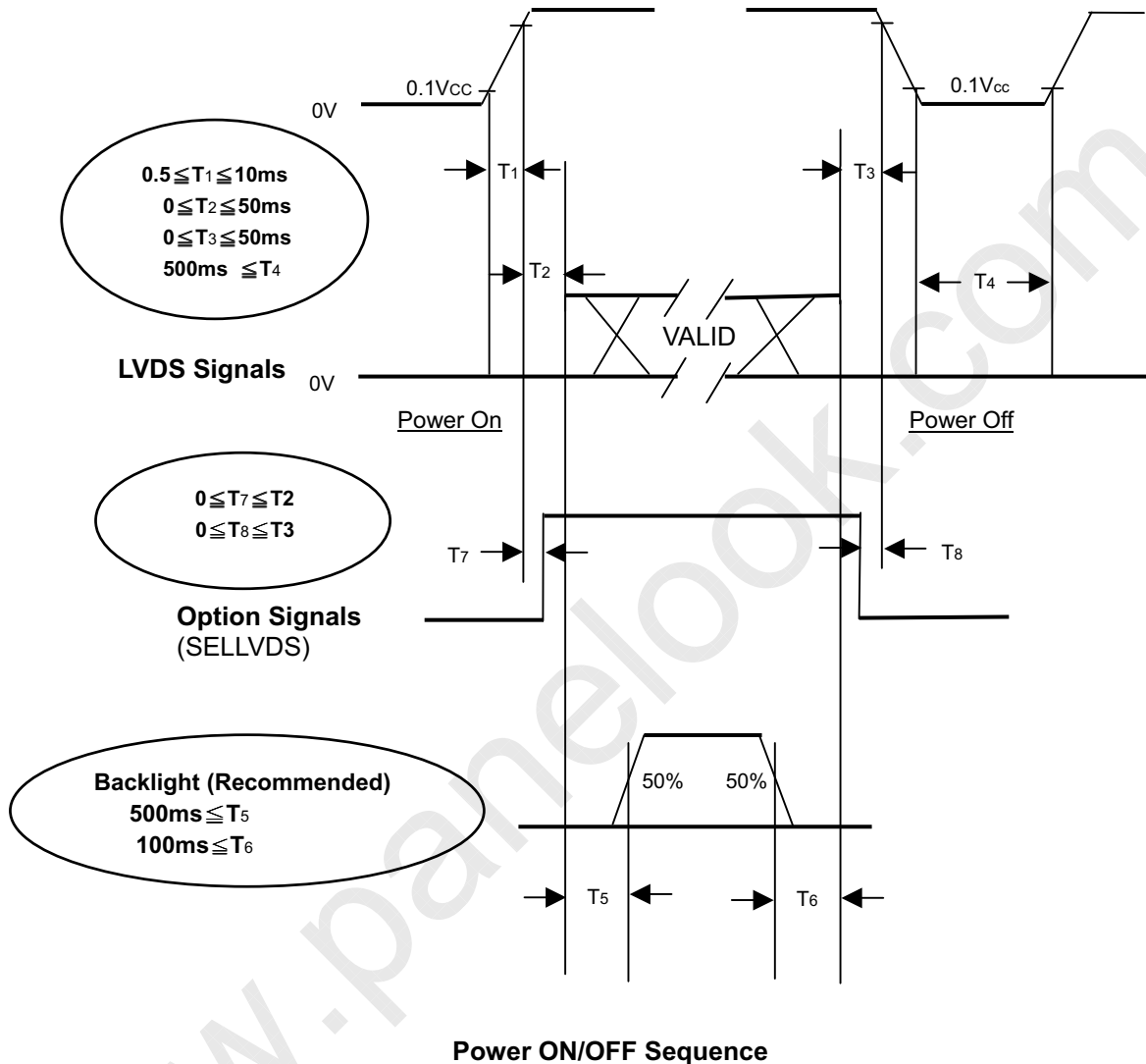

Note.

- (1) The supply voltage of the external system for the module input should follow the definition of Vcc.
- (2) Apply the lamp voltage within the LCD operation range. When the backlight turns on before the LCD operation or the LCD turns off before the backlight turns off, the display may momentarily become abnormal screen. There is no reliability issue when the T5, T6 timing missing the range.
- (3) In case of VCC is in off level, please keep the level of input signals on the low or high impedance.
- (4) T4 should be measured after the module has been fully discharged between power off and on period.
- (5) Interface signal shall not be kept at high impedance when the power is on.

7. OPTICAL CHARACTERISTICS

7.1 TEST CONDITIONS

Item	Symbol	Value	Unit
Ambient Temperature	Ta	25±2	°C
Ambient Humidity	Ha	50±10	%RH
Supply Voltage	V _{CC}	5.0	V
Input Signal	According to typical value in "3. ELECTRICAL CHARACTERISTICS"		
Lamp Current	I _L	12.3 ± 0.5	mA
Oscillating Frequency (Inverter)	F _w	63±3	KHz
Frame rate	Fr	60	Hz

7.2 OPTICAL SPECIFICATIONS

The relative measurement methods of optical characteristics are shown in 7.2. The following items should be measured under the test conditions described in 7.1 and stable environment shown in Note (6).

Item		Symbol	Condition	Min.	Typ.	Max.	Unit	Note	
Contrast Ratio		CR	$\theta_x=0^\circ, \theta_y=0^\circ$ Viewing Angle at Normal Direction	3500	4500	-	-	(2)	
Response Time		Gray to gray average		-	6.5	12	ms	(3)	
Center Luminance of White		L _c		450	500	-	cd/m ²	(4)	
White Variation		δW		-	-	1.3	-	(7)	
Cross Talk		CT		-	-	4.0	%	(5)	
Color Chromaticity	Red	R _x		Typ -0.03	Typ +0.03	0.633	-	-	(6)
		R _y				0.322			
	Green	G _x				0.280			
		G _y				0.607			
	Blue	B _x				0.146			
		B _y	0.055						
	White	W _x	0.280						
W _y		0.290							
Color Gamut		CG	68	72	-	%	NTSC		
Viewing Angle	Horizontal	θ _{x+}	CR≥20	80	88	-	Deg.	(1)	
		θ _{x-}							
	Vertical	θ _{y+}							
		θ _{y-}							

Note (1) Definition of Viewing Angle (θ_x , θ_y):

Viewing angles are measured by EZ-Contrast 160R (Eldim)

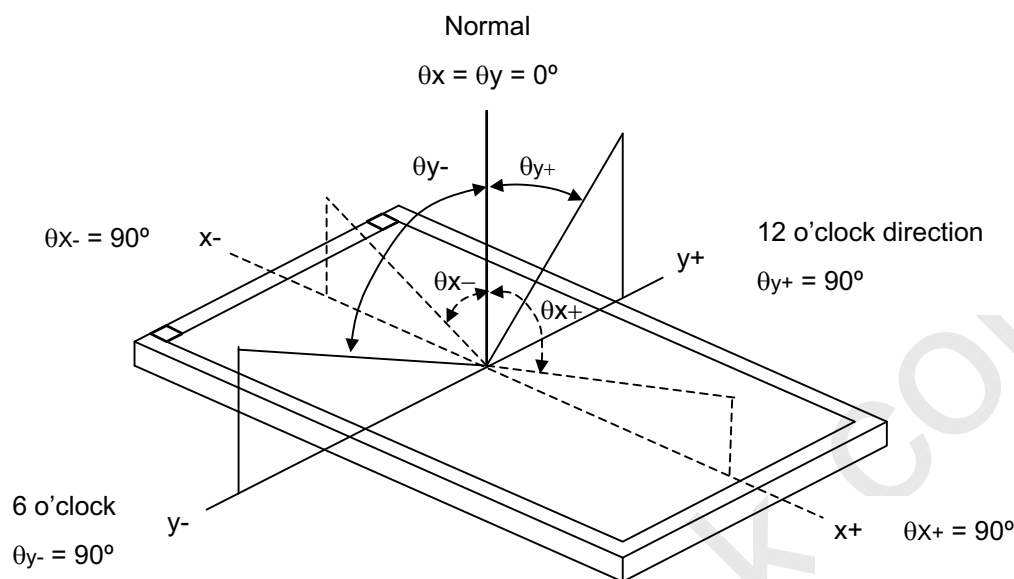

Note (2) Definition of Contrast Ratio (CR):

The contrast ratio can be calculated by the following expression.

$$\text{Contrast Ratio (CR)} = L_{255} / L_0$$

L255: Luminance of gray level 255

L 0: Luminance of gray level 0

CR = CR (5), where CR (X) is corresponding to the Contrast Ratio of the point X at the figure in Note (7).

Note (3) Definition of Gray to Gray Switching Time :

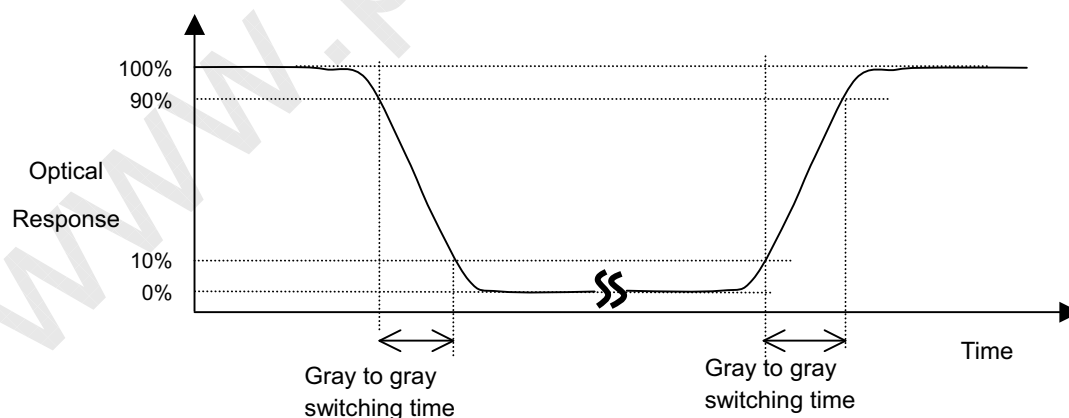

The driving signal means the signal of luminance 0%, 20%, 40%, 60%, 80%, 100%.

Gray to gray average time means the average switching time of luminance 0%, 20%, 40%, 60%, 80%, 100% to each other.

Note (4) Definition of Luminance of White (L_C , L_{AVE}):

Measure the luminance of gray level 255 at center point and 5 points

$$L_C = L(5)$$

$$L_{AVE} = [L(1) + L(2) + L(3) + L(4) + L(5)] / 5$$

where $L(x)$ is corresponding to the luminance of the point X at the figure in Note (7).

Note (5) Definition of Cross Talk (CT):

$$CT = |Y_B - Y_A| / Y_A \times 100 (\%)$$

Where:

(a)

Y_A = Luminance of measured location without gray level 255 pattern (cd/m^2)

Y_B = Luminance of measured location with gray level 255 pattern (cd/m^2)

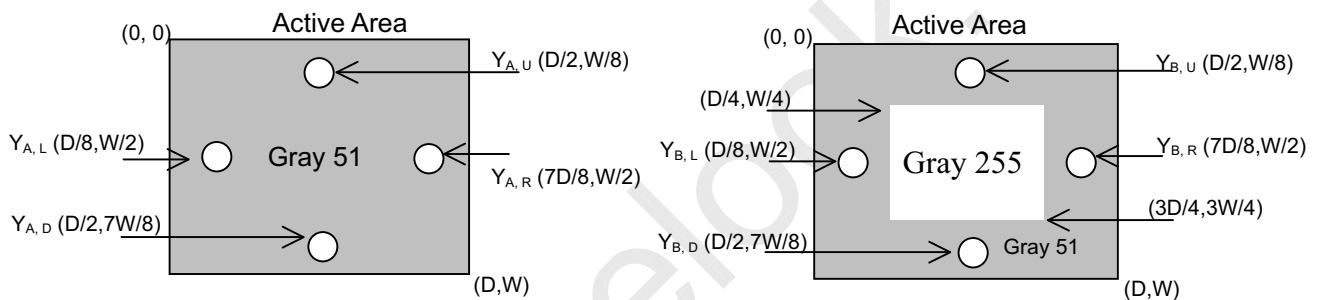

(b)

Y_A = Luminance of measured location without gray level 255 pattern (cd/m^2)

Y_B = Luminance of measured location with gray level 255 pattern (cd/m^2)

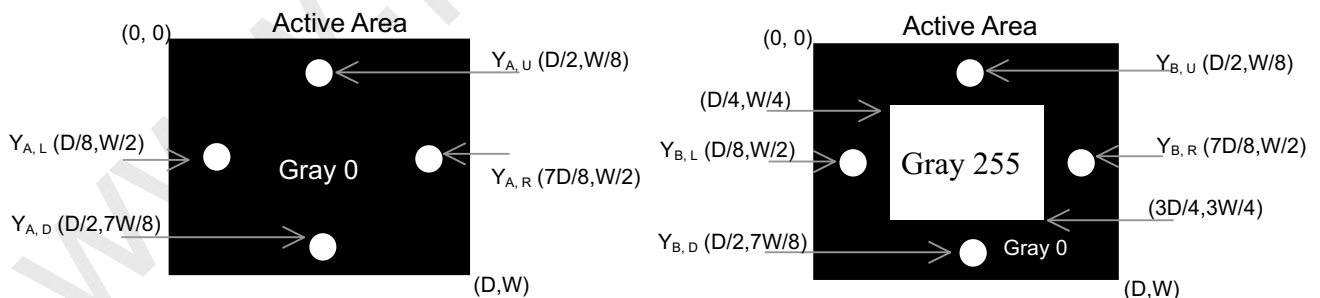

Note (6) Measurement Setup:

The LCD module should be stabilized at given temperature for 1 hour to avoid abrupt temperature change during measuring. In order to stabilize the luminance, the measurement should be executed after lighting Backlight for 1 hour in a windless room.

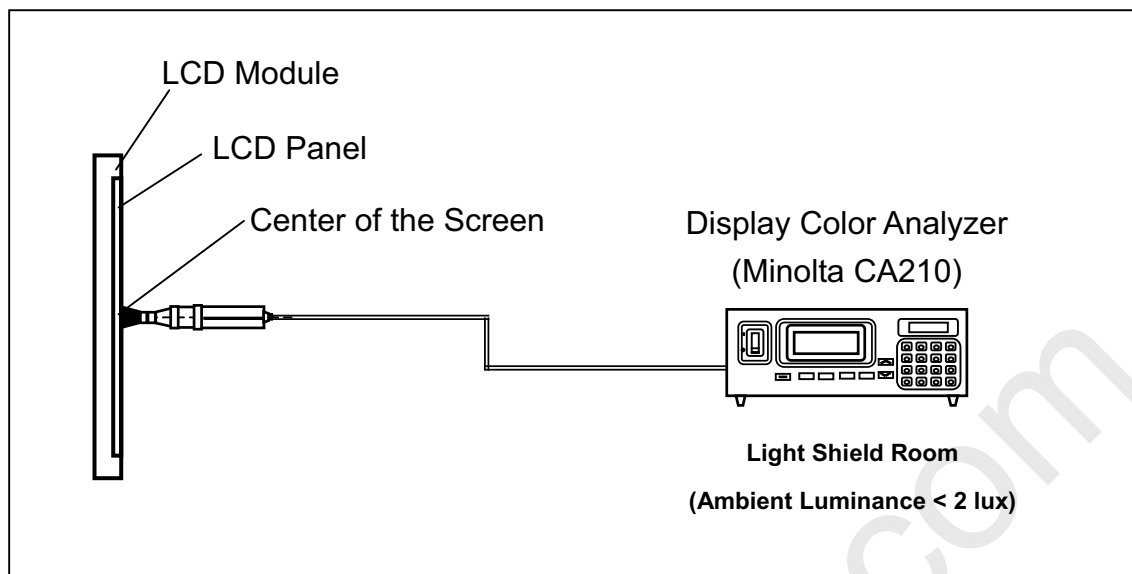

Note (7) Definition of White Variation (δW):

Measure the luminance of gray level 255 at 5 points

$$\delta W = \text{Maximum} [L(1), L(2), L(3), L(4), L(5)] / \text{Minimum} [L(1), L(2), L(3), L(4), L(5)]$$

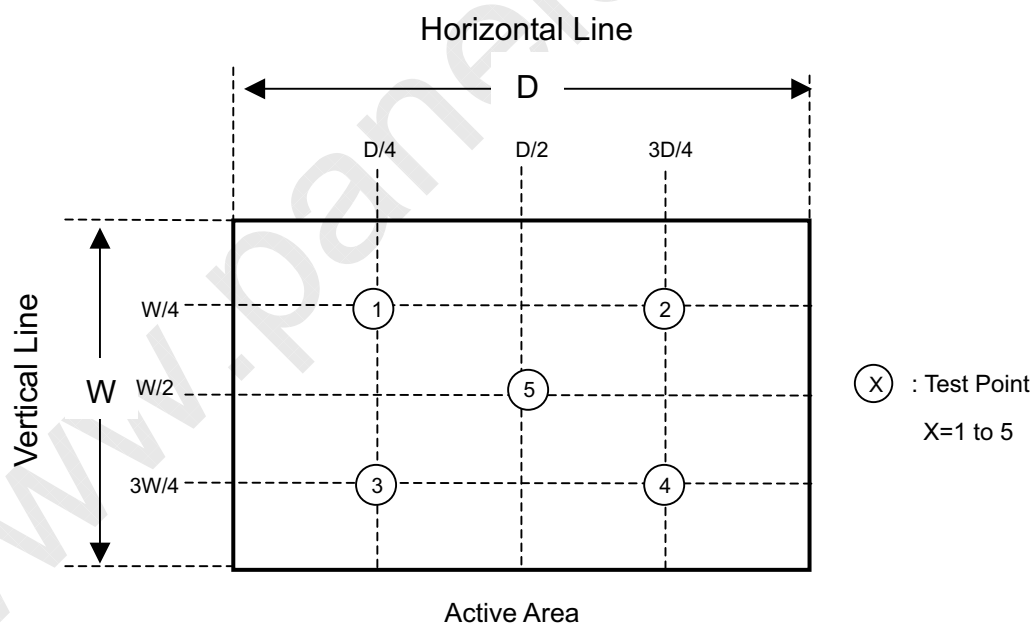

8. DEFINITION OF LABELS

8.1 CMO MODULE LABEL

The barcode nameplate is pasted on each module as illustration, and its definitions are as following explanation.

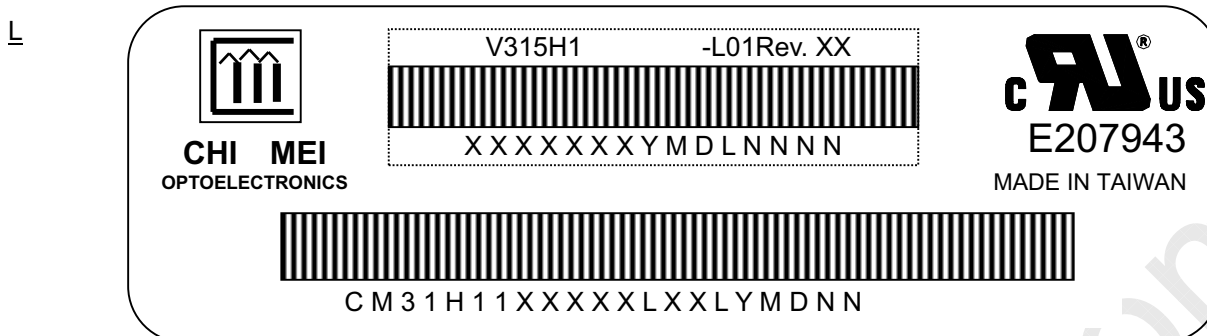

(a) Model Name: V315H1-L01

(b) Revision: Rev. XX, for example: A0, A1... B1, B2... or C1, C2...etc.

(c) Serial ID: XXXXXXXXYMDLN

Code	Meaning	Description
XX	CMO internal use	-
XX	Revision	Cover all the change
X-XX	CMO internal use	-
YMD	Year, month, day	Year: 2001=1, 2002=2, 2003=3, 2004=4... Month: Jan. ~ Dec.=1, 2, 3, ~, 9, A, B, C Day: 1 st to 31 st =1, 2, 3, ~, 9, A, B, C, ~, W, X, Y, exclude I, O, and U
L	Product line #	Line 1=1, Line 2=2, Line 3=3, ...
NNNN	Serial number	Manufacturing sequence of product

(d) Production Location:XXXX, for example:TAIWAN or CHINA .

(e) Customer's barcode definition:

Serial ID:CM 3 1 H 1 1 X X X X X L X X L Y M D N N N N

Code	Meaning	Description
CM	Supplier code	CMO=CM
31H11	Model number	V315H1-L01=31H11
X	Revision code	C1=1,C2=2,C3=3.....
X	Source driver IC code	Century=1, CLL=2, Demos=3, Epson=4, Fujitsu=5, Himax=6, Hitachi=7, Hynix=8, LDI=9, Matsushita=A, NEC=B, Novatec=C,
X	Gate driver IC code	OKI=D, Philips=E, Renasas=F, Samsung=G, Sanyo=H, Sharp=I, TI=J, Topro=K, Toshiba=L, Windbond=M
XX	Cell location	Tainan, Taiwan=TN
L	Cell line #	1~12=0~C
XX	Module location	Tainan, Taiwan=TN
L	Module line #	1~12=0~C
YMD	Year, month, day	Year: 2001=1, 2002=2, 2003=3, 2004=4... Month: Jan. ~ Dec.=1, 2, 3, ~, 9, A, B, C Day: 1 st to 31 st =1, 2, 3, ~, 9, A, B, C, ~, W, X, Y, exclude I, O, and U
NNNN	Serial number	By LCD supplier

9. PACKAGING

9.1 PACKING SPECIFICATIONS

- (1) 5 LCD TV modules / 1 Box
- (2) Box dimensions : 834(L) X 380 (W) X 530 (H)
- (3) Weight : approximately 38.5Kg (5 modules per box)

9.2 PACKING METHOD

Figures 9-1 and 9-2 are the packing method

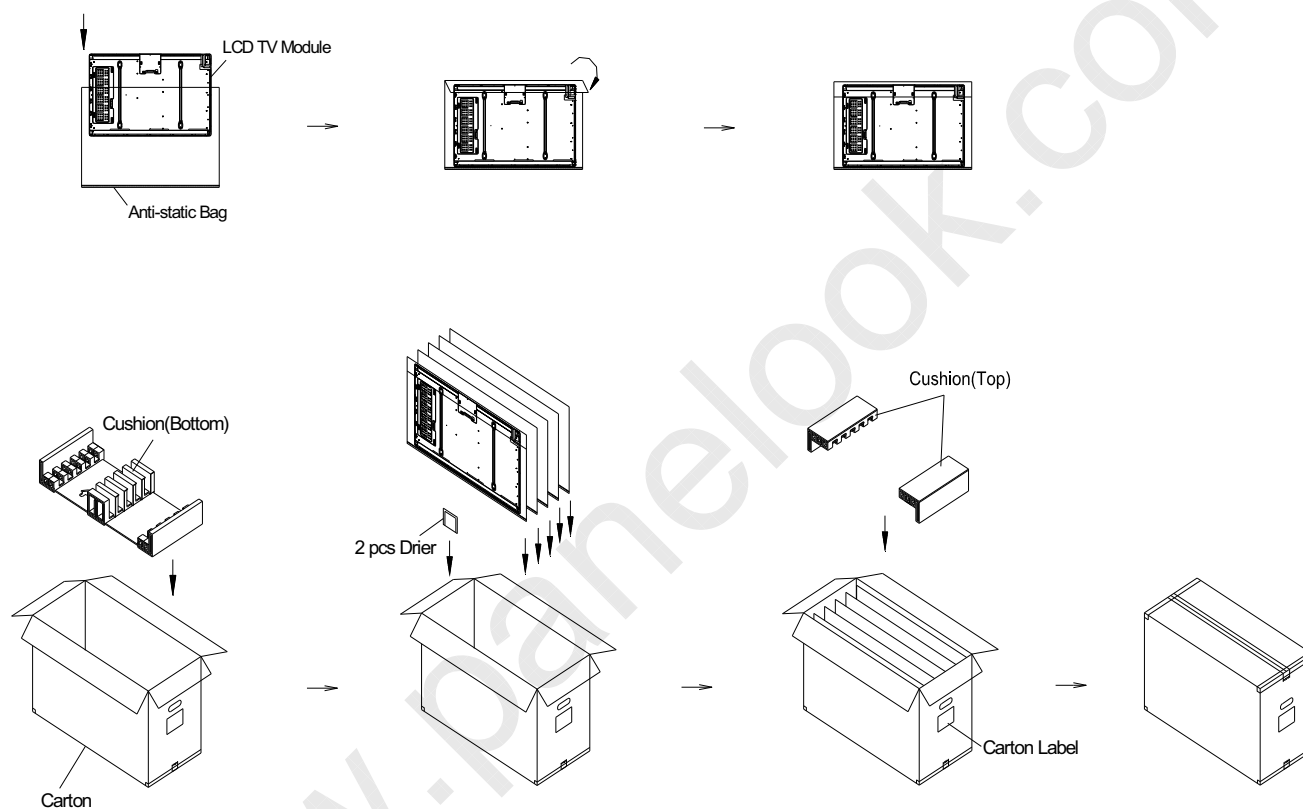
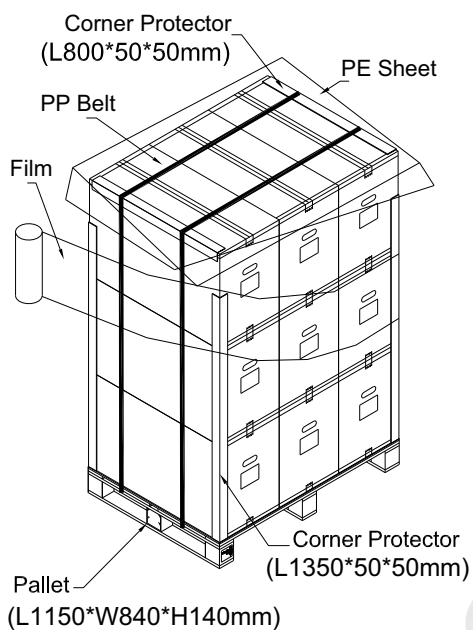
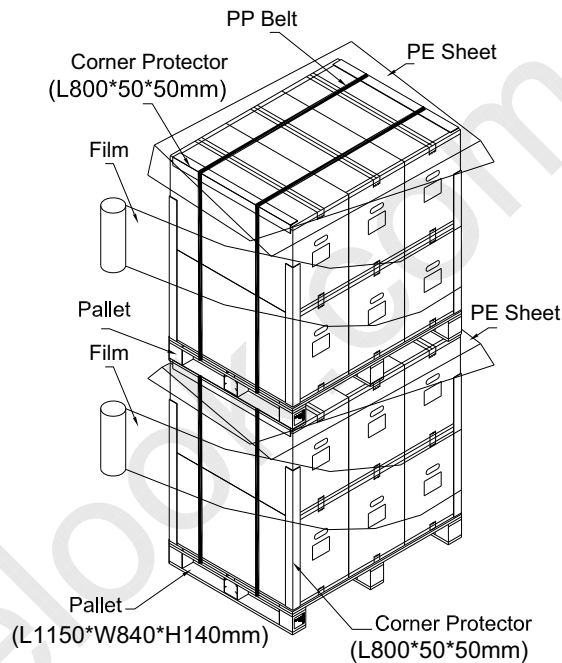

Figure.9-1 packing method

Sea / Land Transportation
(40ft Container)



Sea / Land Transportation
(40ft HQ Container)



Air Transportation

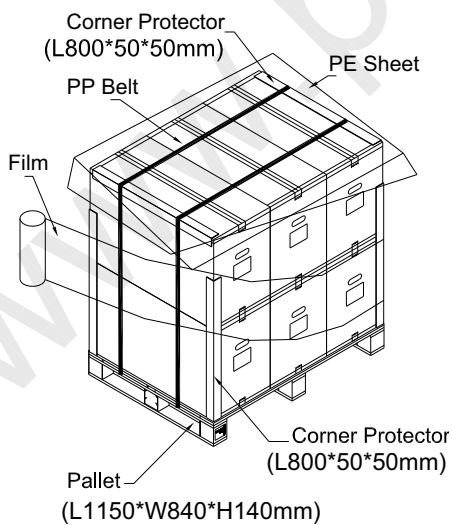

Figure.9-2 packing method

10. PRECAUTIONS

10.1 ASSEMBLY AND HANDLING PRECAUTIONS

- (1) Do not apply rough force such as bending or twisting to the module during assembly.
- (2) It is recommended to assemble or to install a module into the user's system in clean working areas. The dust and oil may cause electrical short or worsen the polarizer.
- (3) Do not apply pressure or impulse to the module to prevent the damage of LCD panel and backlight.
- (4) Always follow the correct power-on sequence when the LCD module is turned on. This can prevent the damage and latch-up of the CMOS LSI chips.
- (5) Do not plug in or pull out the I/F connector while the module is in operation.
- (6) Do not disassemble the module.
- (7) Use a soft dry cloth without chemicals for cleaning, because the surface of polarizer is very soft and easily scratched.
- (8) Moisture can easily penetrate into LCD module and may cause the damage during operation.
- (9) High temperature or humidity may deteriorate the performance of LCD module. Please store LCD modules in the specified storage conditions.
- (10) When ambient temperature is lower than 10°C, the display quality might be reduced. For example, the response time will become slow, and the starting voltage of CCFL will be higher than that of room temperature.

10.2 SAFETY PRECAUTIONS

- (1) The startup voltage of a backlight is over 1000 Volts. It may cause an electrical shock while assembling with the inverter. Do not disassemble the module or insert anything into the backlight unit.
- (2) If the liquid crystal material leaks from the panel, it should be kept away from the eyes or mouth. In case of contact with hands, skin or clothes, it has to be washed away thoroughly with soap.
- (3) After the module's end of life, it is not harmful in case of normal operation and storage.

10.3 SAFETY STANDARDS

The LCD module should be certified with safety regulations as follows:

Regulatory	Item	Standard
Information Technology equipment	UL	UL 60950-1: 2 nd Edition
	cUL	CAN/CSA C22.2 No.60950-1-07
	CB	IEC 60950-1:2005
Audio/Video Apparatus	UL	UL 60065:7 th Edition
	cUL	CAN/CSA C22.2 No.60065-03
	CB	IEC 60065:2001

If the module displays the same pattern for a long period of time, the phenomenon of image sticking may be occurred.

11. MECHANICAL CHARACTERISTICS

