

- Tentative Specification
 Preliminary Specification
 Approval Specification

MODEL NO.: V315H3
SUFFIX: L03

Customer:	
APPROVED BY	SIGNATURE
Name / Title _____	_____
Note	
Please return 1 copy for your confirmation with your signature and comments.	

Approved By	Checked By	Prepared By
Chao-Chun Chung	Vincent Chou	Wayne Lin

CONTENTS

1. GENERAL DESCRIPTION	5
1.1 OVERVIEW	5
1.2 FEATURES	5
1.3 APPLICATION	5
1.4 GENERAL SPECIFICATIONS	5
1.5 MECHANICAL SPECIFICATIONS	6
2. ABSOLUTE MAXIMUM RATINGS	7
2.1 ABSOLUTE RATINGS OF ENVIRONMENT	7
2.2 PACKAGE STORAGE	8
2.3 ELECTRICAL ABSOLUTE RATINGS	8
2.3.1 TFT LCD MODULE	8
2.3.2 BACKLIGHT INVERTER UNIT	8
3. ELECTRICAL CHARACTERISTICS	9
3.1 TFT LCD MODULE	9
3.2 BACKLIGHT CONNECTOR PIN CONFIGURATION	11
3.2.1 LAMP SPECIFICATION	11
3.2.2 ELECTRICAL SPECIFICATION	11
3.2.3 INVERTER INTERFACE CHARACTERISTICS	13
4.1 TFT LCD MODULE	15
5. INPUT TERMINAL PIN ASSIGNMENT	16
5.1 TFT LCD Module Input	16
5.2 BACKLIGHT UNIT	18
5.3 INVERTER UNIT	19
5.4 BLOCK DIAGRAM OF INTERFACE	20
5.5 LVDS INTERFACE	21
5.6 COLOR DATA INPUT ASSIGNMENT	22
6. INTERFACE TIMING	23
6.1 INPUT SIGNAL TIMING SPECIFICATIONS	23
6.2 POWER ON/OFF SEQUENCE	26
7. OPTICAL CHARACTERISTICS	27
7.1 TEST CONDITIONS	27
7.2 OPTICAL SPECIFICATIONS	28

8. PRECAUTIONS.....	31
8.1 ASSEMBLY AND HANDLING PRECAUTIONS	31
8.2 SAFETY PRECAUTIONS	31
9. DEFINITION OF LABELS.....	32
9.1 CMI MODULE LABEL	32
10. PACKAGING.....	33
10.1 PACKAGING SPECIFICATIONS	33
10.2 PACKAGING METHOD.....	33
11. MECHANICAL CHARACTERISTIC.....	35

REVISION HISTORY

Version	Date	Page(New)	Section	Description
Ver. 0.0	Mar. 01, 2011	All	All	The preliminary specification was first issued.
Ver. 1.0	Apr. 15, 2011	All	All	The approval specification was first issued.

1. GENERAL DESCRIPTION

1.1 OVERVIEW

V315H3-L03 is a 31.5" TFT Liquid Crystal Display module with 4-CCFL Backlight unit and 2ch-LVDS interface. This module supports 1920 x 1080 Full HDTV format and can display 16.7M colors (8-bit). The inverter module for backlight is built-in.

1.2 FEATURES

- High brightness (400 nits)
- High contrast ratio (5000:1)
- Fast response time (Gray to gray average 8 ms)
- High color saturation (NTSC 72%)
- Full HDTV (1920 x 1080 pixels) resolution, true HDTV format
- DE (Data Enable) only mode
- LVDS (Low Voltage Differential Signaling) interface
- Optimized response time for 60 Hz frame rate
- Viewing Angle: 176(H)/176(V) (CR>20) MVA Technology
- RoHs compliance

1.3 APPLICATION

- Standard Living Room TVs
- Public Display Application
- Home Theater Application
- MFM Application

1.4 GENERAL SPECIFICATIONS

Item	Specification	Unit	Note
Active Area	698.4 (H) x 392.85 (V)	mm	(1)
Bezel Opening Area	703.8 (H) x 399 (V)	mm	
Driver Element	a-si TFT active matrix	-	-
Pixel Number	1920 x R.G.B. x 1080	pixel	-
Pixel Pitch(Sub Pixel)	0.121 (H) x 0.364 (V)	mm	-
Pixel Arrangement	RGB vertical stripe	-	-
Power consumption	80.96 W (LVDS input Power 6.96 W + Backlight Power 74 W)	Watt	(2)
Display Colors	16.7M	color	-
Display Operation Mode	Transmissive mode / Normally Black	-	-
Surface Treatment	Anti-Glare coating (Haze 11%),Hard coating (3H)	-	-

Note (1) Please refer to the attached drawings in chapter 11 for more information about the front and back outlines.

Note (2) Please refer sec 3.1 and 3.2 for more information of Power consumption

1.5 MECHANICAL SPECIFICATIONS

Item		Min.	Typ.	Max.	Unit	Note
Module Size	Horizontal (H)	759	760	761	mm	(1)
	Vertical (V)	449	450	451	mm	(1)
	Depth (D)	40.3	41.3	42.3	mm	(2)
	Depth (D)	46.9	47.9	48.9	mm	(3)
Weight		-	5150	-	g	-

Note (1) Please refer to the attached drawings for more information of front and back outline dimensions.

Note (2) Module Depth is between bezel to T-CON cover.

Note (3) Module Depth is between bezel to Inverter cover.

2. ABSOLUTE MAXIMUM RATINGS

2.1 ABSOLUTE RATINGS OF ENVIRONMENT

Item	Symbol	Value		Unit	Note
		Min.	Max.		
Storage Temperature	TST	-20	+60	°C	(1)
Operating Ambient Temperature	TOP	0	50	°C	(1), (2)
Shock (Non-Operating)	SNOP	-	50	G	(3), (5)
Vibration (Non-Operating)	VNOP	-	1.0	G	(4), (5)

Note (1) Temperature and relative humidity range is shown in the figure below.

(a) 90 %RH Max. ($T_a \leq 40$ °C).

(b) Wet-bulb temperature should be 39 °C Max. ($T_a > 40$ °C).

(c) No condensation.

Note (2) The maximum operating temperature is based on the test condition that the surface temperature of display area is less than or equal to 65 °C with LCD module alone in a temperature controlled chamber. Thermal management should be considered in final product design to prevent the surface temperature of display area from being over 65 °C. The range of operating temperature may degrade in case of improper thermal management in final product design.

Note (3) 11 ms, half sine wave, 1 time for $\pm X$, $\pm Y$, $\pm Z$.

Note (4) 10 ~ 200 Hz, 10 min, 1 time each X, Y, Z.

Note (5) At testing Vibration and Shock, the fixture in holding the module has to be hard and rigid enough so that the module would not be twisted or bent by the fixture.

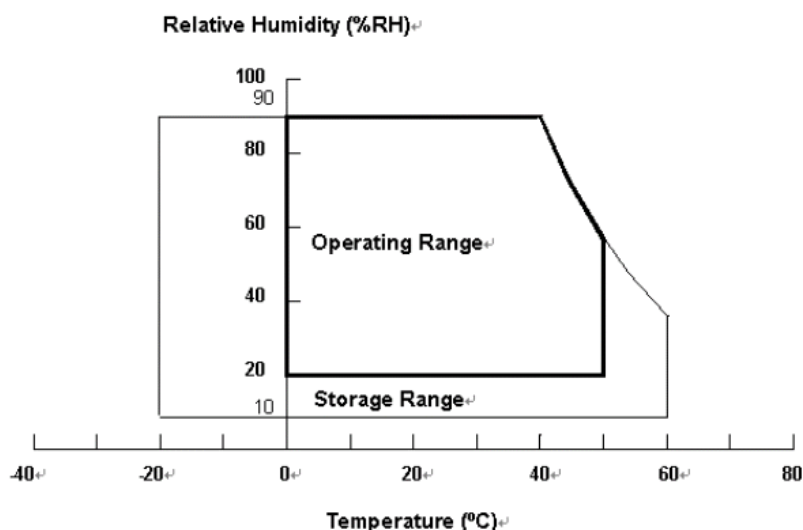

2.2 PACKAGE STORAGE

When storing modules as spares for a long time, the following precaution is necessary.

- (a) Do not leave the module in high temperature, and high humidity for a long time, It is highly recommended to store the module with temperature from 0 to 35 °C at normal humidity without condensation.
- (b) The module shall be stored in dark place. Do not store the TFT-LCD module in direct sunlight or fluorescent light.

2.3 ELECTRICAL ABSOLUTE RATINGS

2.3.1 TFT LCD MODULE

Item	Symbol	Value		Unit	Note
		Min.	Max.		
Power Supply Voltage	VCC	-0.3	13.5	V	(1)
Logic Input Voltage	VIN	-0.3	3.6	V	

2.3.2 BACKLIGHT INVERTER UNIT

Item	Symbol	Value		Unit	Note
		Min.	Max.		
Lamp Voltage	VW	—	3000	VRMS	
Power Supply Voltage	VBL	0	30	V	(1)
Control Signal Level	—	-0.3	7	V	(1), (3)

Note (1) Permanent damage to the device may occur if maximum values are exceeded. Function operation should be restricted to the conditions described under Normal Operating Conditions.

Note (2) No moisture condensation or freezing.

Note (3) The control signals include On/Off Control and Internal PWM Control.

3. ELECTRICAL CHARACTERISTICS
3.1 TFT LCD MODULE

(Ta = 25 ± 2 °C)

Parameter		Symbol	Value			Unit	Note
			Min.	Typ.	Max.		
Power Supply Voltage		V _{CC}	10.8	12	13.2	V	(1)
Rush Current		I _{RUSH}	—	—	2.8	A	(2)
Power Supply Current	White Pattern	—	—	0.38	—	A	(3)
	Horizontal Stripe	—	—	0.58	0.62	A	
	Black Pattern	—	—	0.3	—	A	
LVDS interface	Differential Input High Threshold Voltage	V _{LVTH}	+100	—	—	mV	(4)
	Differential Input Low Threshold Voltage	V _{LVTL}	—	—	-100	mV	
	Common Input Voltage	V _{CM}	1.0	1.2	1.4	V	
	Differential input voltage (single-end)	V _{ID}	200	—	600	mV	
	Terminating Resistor	R _T	—	100	—	ohm	
CMIS interface	Input High Threshold Voltage	V _{IH}	2.7	—	3.3	V	
	Input Low Threshold Voltage	V _{IL}	0	—	0.7	V	

Note (1) The module should be always operated within the above ranges.

Note (2) Measurement condition:

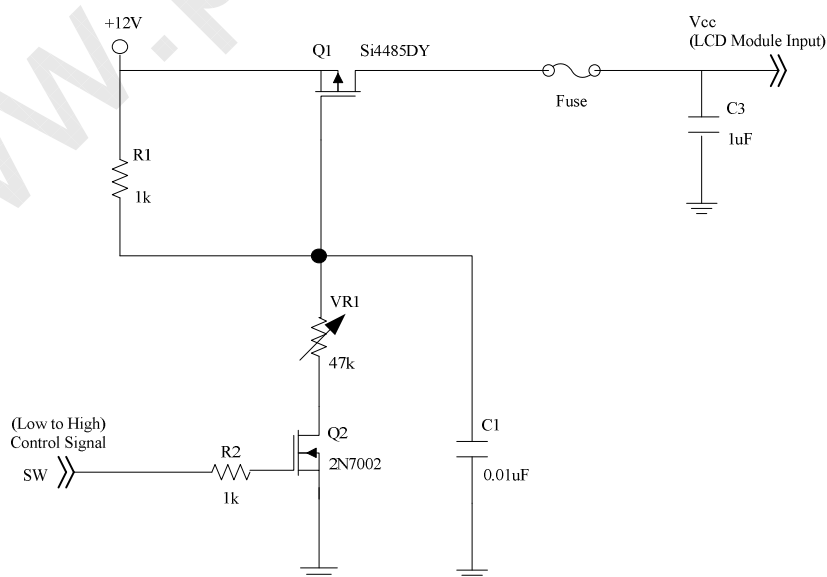

Vcc rising time is 470us

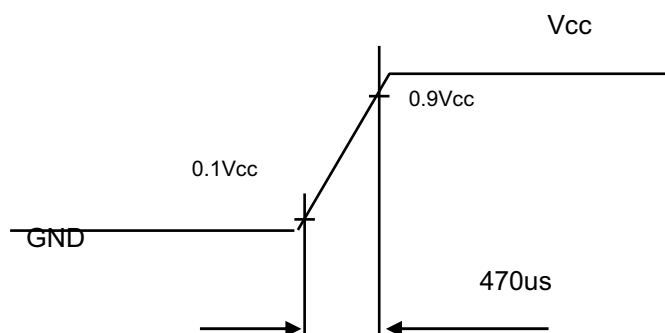

Note (3) The specified power supply current is under the conditions at $V_{cc} = 12\text{ V}$, $T_a = 25 \pm 2\text{ }^\circ\text{C}$, $f_v = 60\text{ Hz}$, whereas a power dissipation check pattern below is displayed.

a. White Pattern

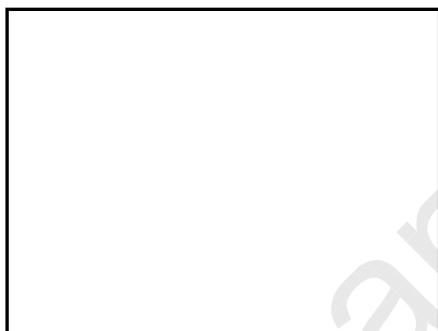

Active Area

b. Black Pattern



Active Area

c. Horizontal Pattern

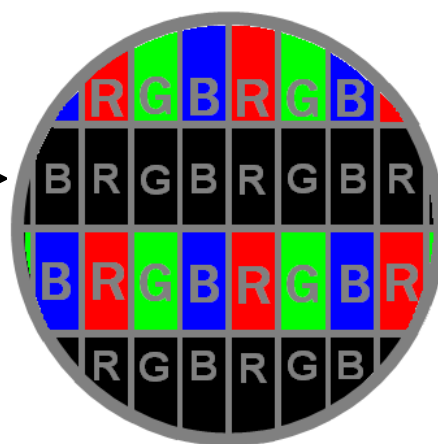
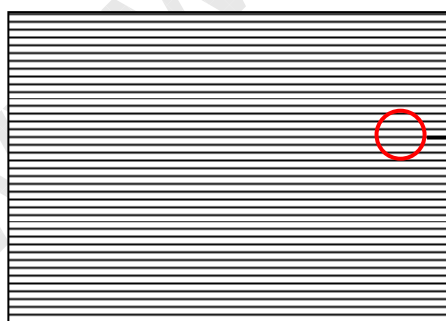

Note (4) The LVDS input characteristics are as follows :

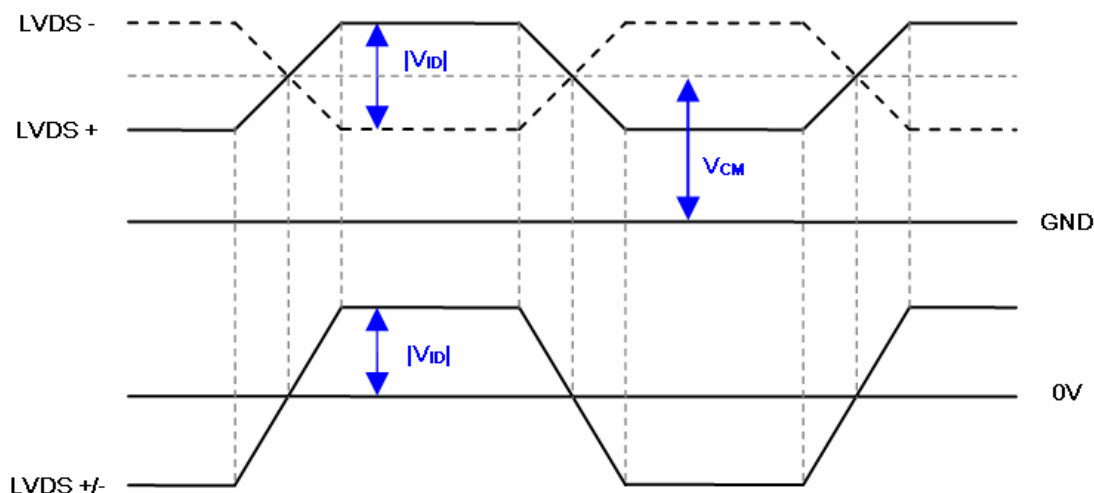

3.2 BACKLIGHT CONNECTOR PIN CONFIGURATION

3.2.1 LAMP SPECIFICATION

($T_a = 25 \pm 2 \text{ }^\circ\text{C}$)

Parameter	Symbol	Value			Unit	Note
		Min.	Typ.	Max.		
Lamp Input Voltage	V_W	-	1560	-	V_{RMS}	$I_L=12.3\text{mA}$
Lamp Current	I_L	11.8	12.3	12.8	mA_{RMS}	
Lamp Turn On Voltage	V_S	-	-	2710	V_{RMS}	(1), $T_a = 0 \text{ }^\circ\text{C}$
		-	-	2260	V_{RMS}	(1), $T_a = 25 \text{ }^\circ\text{C}$
Operating Frequency	F_O	30	-	80	KHz	(2)
Lamp Life Time	L_{BL}	50,000	-	-	Hrs	(3)

3.2.2 ELECTRICAL SPECIFICATION

($T_a = 25 \pm 2 \text{ }^\circ\text{C}$)

Parameter	Symbol	Value			Unit	Note
		Min.	Typ.	Max.		
Total Power Consumption	P_{255}	-	74	78	W	(5), (6), $I_L=12.3\text{mA}$
Power Supply Voltage	V_{BL}	22.8	24.0	25.2	VDC	
Power Supply Current	I_{BL}	-	3.08	3.25	A	Non Dimming
Inrush current	I_R	-	-	4.8	A_{peak}	$V_{BL}=24\text{V}, (I_L=\text{typ})$ (7)

Input Ripple Noise	-	-	-	912	mVP-P	VBL=22.8V
Oscillating Frequency	F _W	55	58	61	kHz	(3)
Dimming Frequency	F _B	150	160	170	Hz	
Minimum Duty Ratio	D _{MIN}	10	20	-	%	(8)

Note (1) Lamp current is measured by utilizing AC current probe.

Note (2) The lamp starting voltage VS should be applied to the lamp for more than 1 second after startup. Otherwise the lamp may not be turned on.

Note (3) The lamp frequency may produce interference with horizontal synchronous frequency of the display input signals, and it may result in line flow on the display. In order to avoid interference, the lamp frequency should be detached from the horizontal synchronous frequency and its harmonics as far as possible.

Note (4) The life time of a lamp is defined as when the brightness is larger than 50% of its original value and the effective discharge length is longer than 80% of its original length (Effective discharge length is defined as an area that has equal to or more than 70% brightness compared to the brightness at the center point of lamp.) as the time in which it continues to operate under the condition at Ta = 25 ±2°C and I_L = 11.8~12.8mA_{rms}.

Note (5) The power supply capacity should be higher than the total inverter power consumption P_{BL}. Since the pulse width modulation (PWM) mode was applied for backlight dimming, the driving current changed as PWM duty on and off. The transient response of power supply should be considered for the changing loading when inverter dimming.

Note (6) The measurement condition of Max. value is based on 31.5" backlight unit under input voltage 24V, average lamp current 12.6 mA and lighting 30 minutes later.

Note (7) The duration of Input Inrush Current is about VBL Rising Time 30ms.

Note (8) 10% minimum duty ratio is only valid for electrical operation.

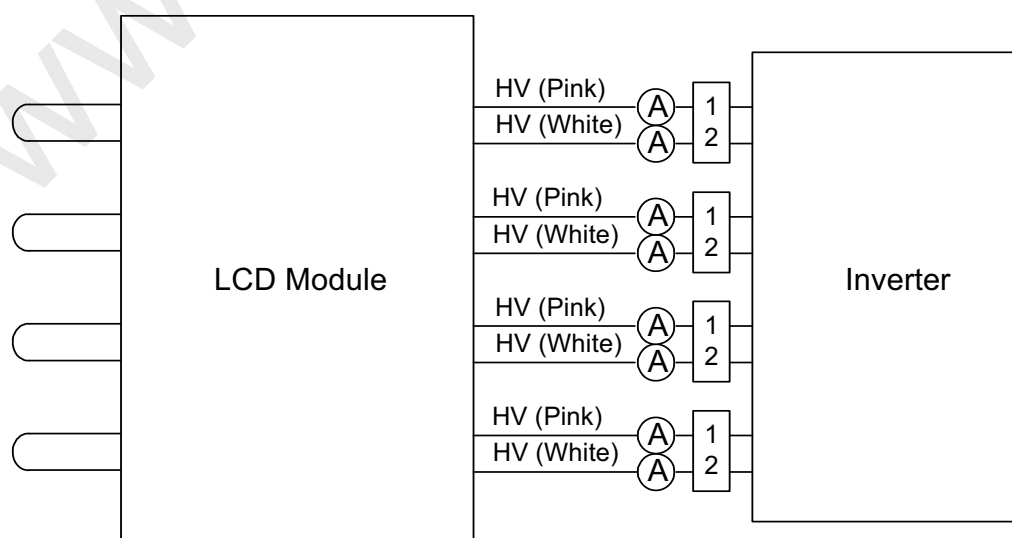

3.2.3 INVERTER INTERFACE CHARACTERISTICS

Parameter	Symbol	Test Condition	Value			Unit	Note	
			Min.	Typ.	Max.			
On/Off Control Voltage	ON	V _{BLON}	—	2.4	—	5.0	V	
	OFF		—	0	—	0.8	V	
Internal PWM Control Voltage	MAX	V _{IPWM}	—	2.85	3.0	3.15	V	Maximum duty ratio
	MIN		—	—	0	—	V	Minimum duty ratio
External PWM Control Voltage	HI	V _{EPWM}	—	2.4	—	5.0	V	Duty on
	LO		—	0	—	0.8	V	Duty off
Error Signal	ERR	—	Open Collector			V	Abnormal	
			0	—	0.8		Normal	
Error Turn on Delay Time	T _{ER-R}	—	—	—	200	ms		
Error Turn off Delay Time	T _{ER-F}	—	—	—	200	ms		
VBL Rising Time	Tr1	—	30	—	—	ms	10%-90%V _{BL}	
VBL Falling Time	Tf1	—	30	—	—	ms		
Control Signal Rising Time	Tr	—	—	—	100	ms		
Control Signal Falling Time	Tf	—	—	—	100	ms		
PWM Signal Rising Time	T _{PWMR}	—	—	—	50	us		
PWM Signal Falling Time	T _{PWMF}	—	—	—	50	us		
Input impedance	R _{IN}	—	1	—	—	MΩ		
PWM Turn on Delay Time	T _{PWMON}	—	500	—	—	ms		
PWM Turn off Delay Time	T _{PWMOFF}	—	1	—	—	ms		
BLON Turn on Delay Time	T _{on}	—	200	—	—	ms		
BLON Turn off Time	T _{off}	—	200	—	—	ms		
BLON Delay Time	T _{on1}	—	300	—	—	ms		

Note (1) The Dimming signal should be valid before backlight turns on by BLON signal. It is inhibited to change the internal/external PWM signal during backlight turn on period.

Note (2) The power sequence and control signal timing are shown in the following figure. For a certain reason, the inverter has a possibility to be damaged with wrong power sequence and control signal timing.

Note (3) While system is turned ON or OFF, the power sequences must follow as below descriptions:

Turn ON sequence: VBL → PWM signal → BLON

Turn OFF sequence: BLOFF → PWM signal → VBL

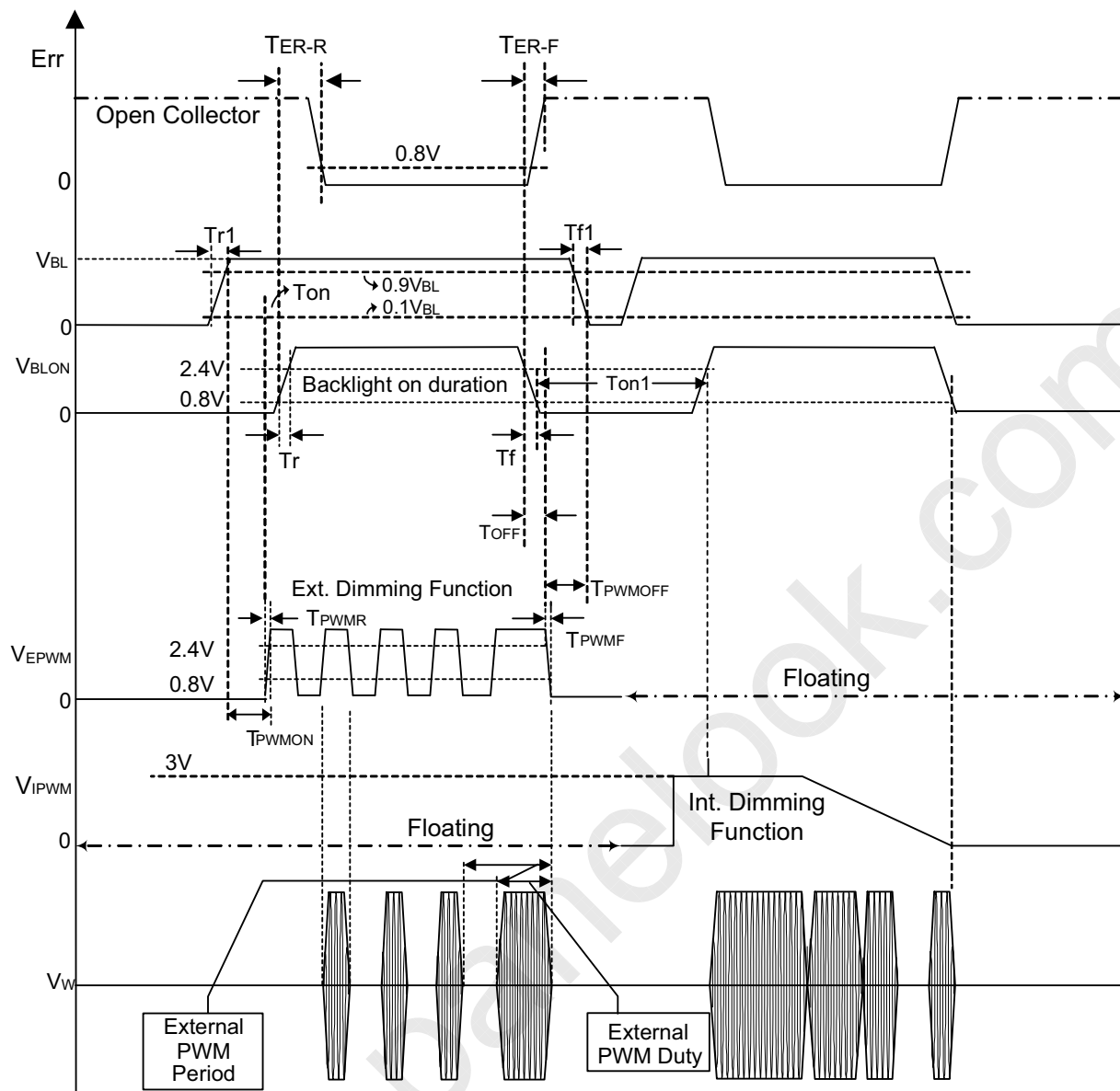

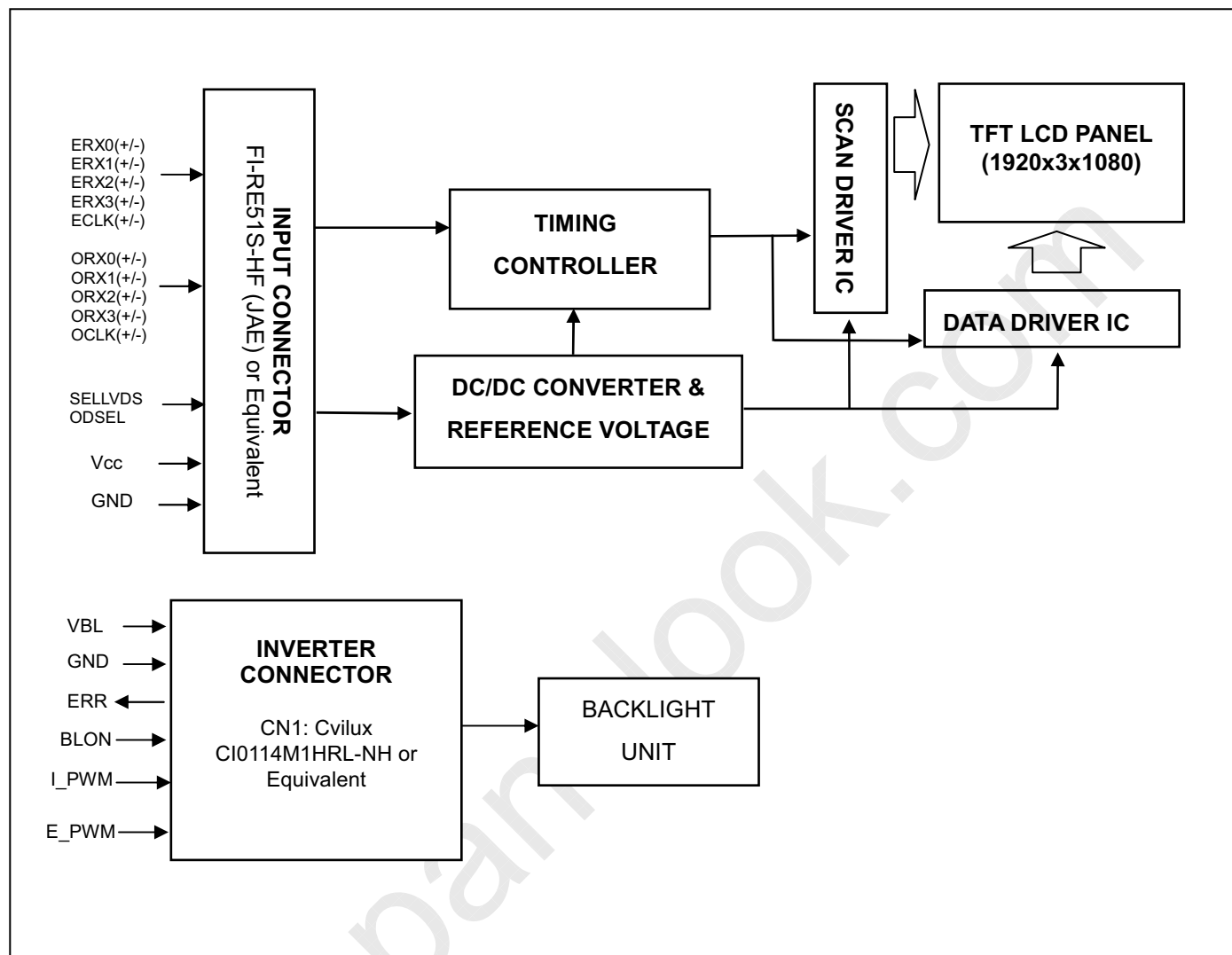
4. BLOCK DIAGRAM OF INTERFACE
4.1 TFT LCD MODULE

5. INPUT TERMINAL PIN ASSIGNMENT

5.1 TFT LCD Module Input

CNF1 Connector Pin Assignment

Pin	Name	Description	Note
1	VCC	+12V power supply	
2	VCC	+12V power supply	
3	VCC	+12V power supply	
4	VCC	+12V power supply	
5	VCC	+12V power supply	
6	N.C.	No Connection	(2)
7	GND	Ground	
8	GND	Ground	
9	GND	Ground	
10	ORX0-	Odd pixel Negative LVDS differential data input. Channel 0	(7)
11	ORX0+	Odd pixel Positive LVDS differential data input. Channel 0	
12	ORX1-	Odd pixel Negative LVDS differential data input. Channel 1	
13	ORX1+	Odd pixel Positive LVDS differential data input. Channel 1	
14	ORX2-	Odd pixel Negative LVDS differential data input. Channel 2	
15	ORX2+	Odd pixel Positive LVDS differential data input. Channel 2	
16	GND	Ground	
17	OCLK-	Odd pixel Negative LVDS differential clock input	(7)
18	OCLK+	Odd pixel Positive LVDS differential clock input.	
19	GND	Ground	
20	ORX3-	Odd pixel Negative LVDS differential data input. Channel 3	(7)
21	ORX3+	Odd pixel Positive LVDS differential data input. Channel 3	
22	N.C.	No Connection	(2)
23	N.C.	No Connection	
24	GND	Ground	
25	ERX0-	Even pixel Negative LVDS differential data input. Channel 0	(7)
26	ERX0+	Even pixel Positive LVDS differential data input. Channel 0	
27	ERX1-	Even pixel Negative LVDS differential data input. Channel 1	
28	ERX1+	Even pixel Positive LVDS differential data input. Channel 1	
29	ERX2-	Even pixel Negative LVDS differential data input. Channel 2	
30	ERX2+	Even pixel Positive LVDS differential data input. Channel 2	
31	GND	Ground	
32	ECLK-	Even pixel Negative LVDS differential clock input.	(7)
33	ECLK+	Even pixel Positive LVDS differential clock input.	
34	GND	Ground	
35	ERX3-	Even pixel Negative LVDS differential data input. Channel 3	(7)
36	ERX3+	Even pixel Positive LVDS differential data input. Channel 3	
37	N.C.	No Connection	(2)
38	N.C.	No Connection	
39	GND	Ground	
40	SCL	EEPROM Serial Clock (for auto Vcom)	
41	SDA	EEPROM Serial Data (for auto Vcom)	
42	N.C.	No Connection	(2)
43	WP	EEPROM Write Protection (for auto Vcom) (0V~0.7V→Disable, 2.7V~3.3V→Enable)	
44	PANEL_SEL	No Connection	(2)
45	SELLVDS	LVDS data format selection (2.7V~3.3V→VESA, 0V~0.7V→	(3)(5)

		JEIDA).	
46	OD_SEL	Overdriving lookup table selection	(4)(6)
47	N.C.	No Connection	(2)
48	N.C.	No Connection	
49	N.C.	No Connection	
50	TCON_RDY	T-CON ready signal	
51	N.C.	No Connection	(2)

Note (1) LVDS connector pin order defined as follows

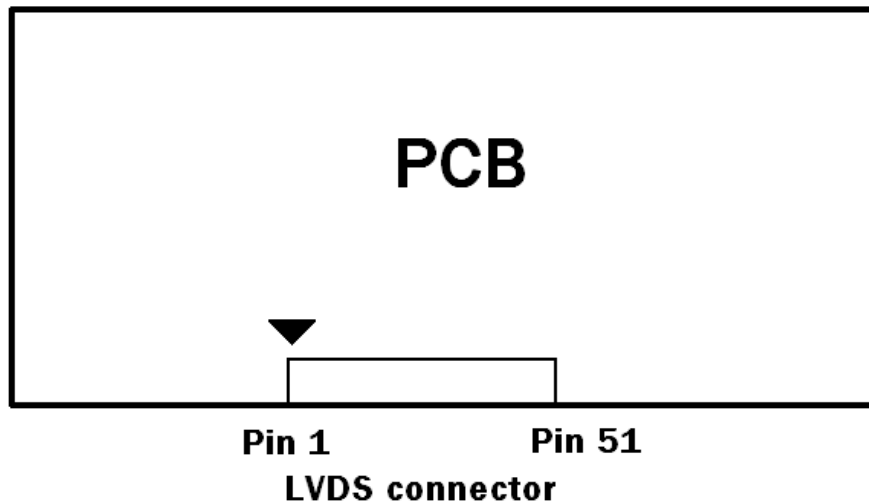

Note (2) Reserved for internal use. Please leave it open.

Note (3) Low = Connect to GND: JEIDA Format, High = Connect to +3.3V: VESA Format.

Note (4) Overdrive lookup table selection. The overdrive lookup table should be selected in accordance with the frame rate to optimize image quality.

Low = Open or connect to GND, High = Connect to +3.3V

ODSEL	Note
L or open	Lookup table was optimized for 60 Hz frame rate.
H	Lookup table was optimized for 60 Hz frame rate.

Note (5) LVDS signal pin connected to the LCM side has the following diagram. R1 in the system side should be less than 1K Ohm. ($R1 < 1K \text{ Ohm}$)

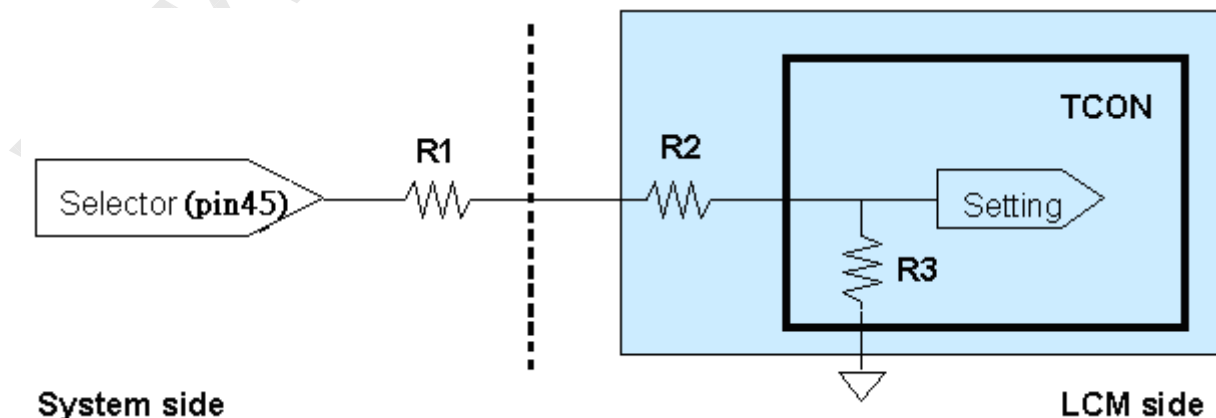

Note (6) ODSEL signal pin connected to the LCM side has the following diagram. R1 in the system side should be less than 1K Ohm. ($R1 < 1K \text{ Ohm}$)

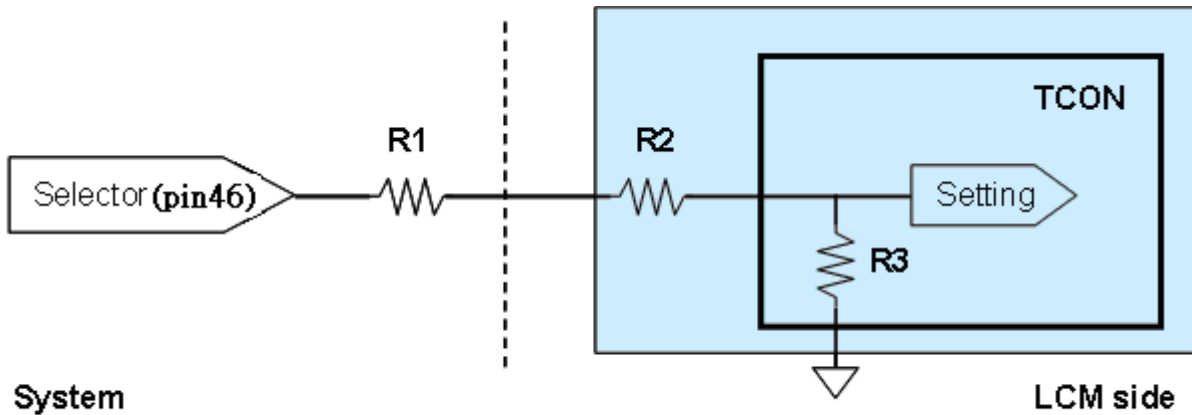

Note (7) Two pixel data send into the module for every clock cycle. The first pixel of the frame is odd pixel and the second pixel is even pixel

5.2 BACKLIGHT UNIT

The pin configuration for the housing and the leader wire is shown in the table below.

CN: E01B-KCF, manufactured by JST or Equivalent

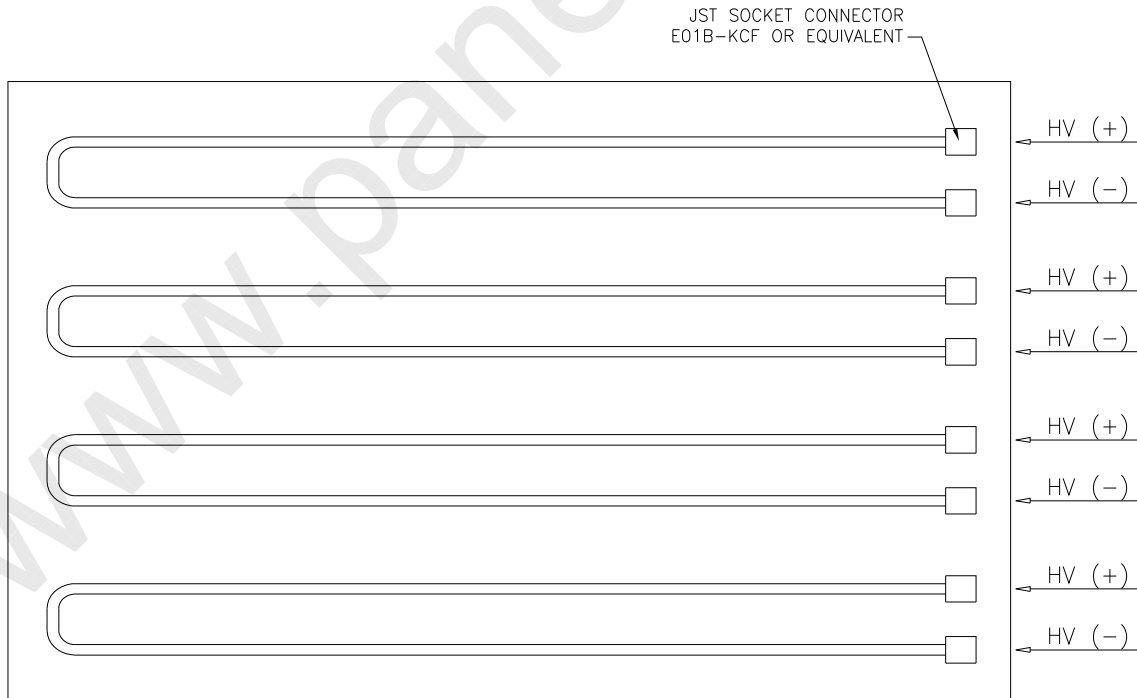

5.3 INVERTER UNIT

CN1: CI0114M1HRL-NH (CviLux)

Pin No	Symbol	Feature
1	VBL	+24V
2		
3		
4		
5		
6	GND	GND
7		
8		
9		
10		
11	ERR	Normal (GND) Abnormal(Open collector)
12	BLON	BL ON/OFF
13	I_PWM	Internal PWM Control
14	E_PWM	External PWM Control

Note (1) PIN 13:Internal PWM Control (Use Pin 13): Pin 14 must open.

Note (2) PIN 14:External PWM Control (Use Pin 14): Pin 13 must open.

Note (3) Pin 13(I_PWM) and Pin 14(E_PWM) can't open in same period.

5.4 BLOCK DIAGRAM OF INTERFACE

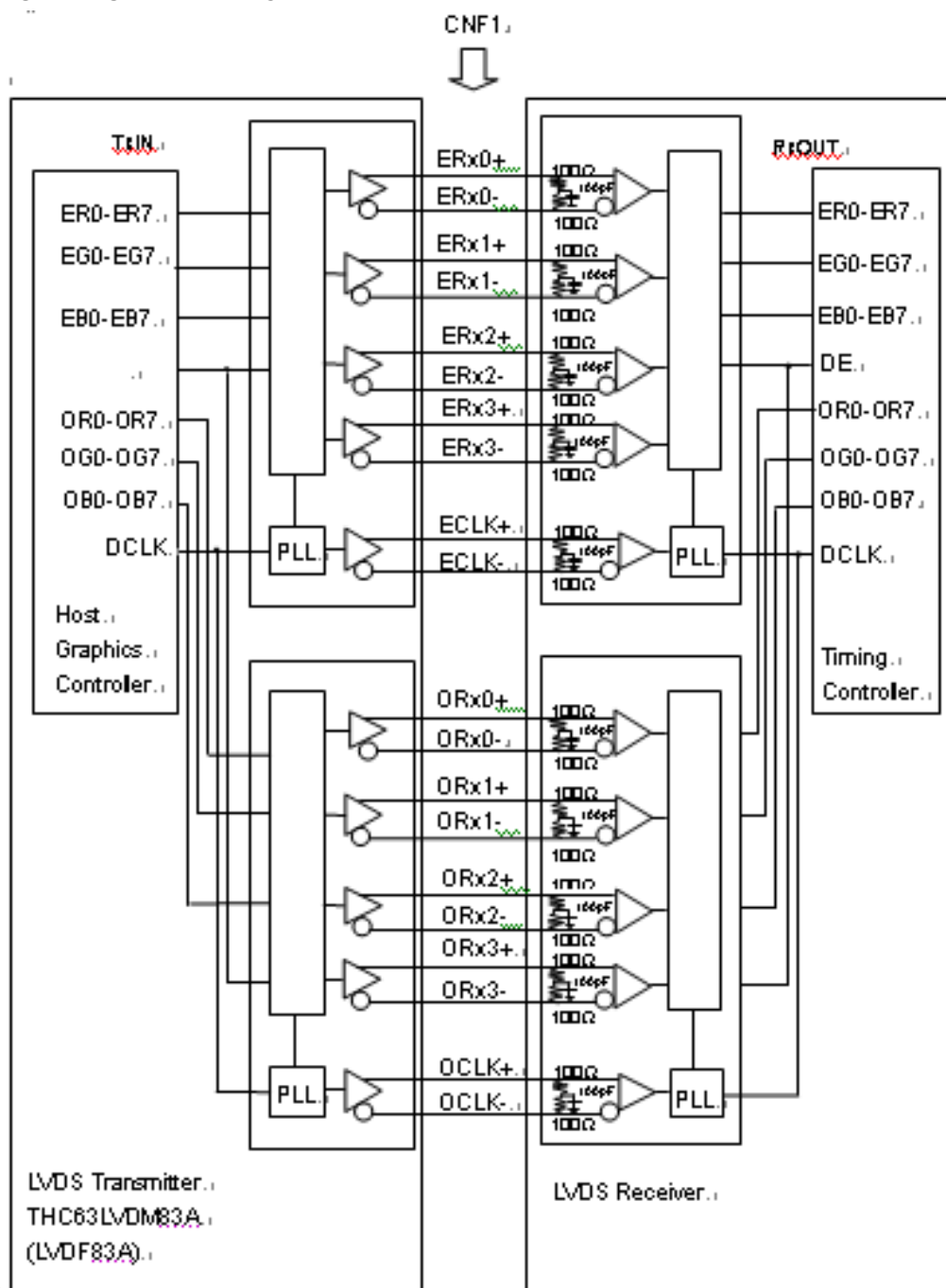

ER0~ER7: Even pixel R data

EG0~EG7: Even pixel G data

EB0~EB7: Even pixel B data

OR0~OR7: Odd pixel R data

OG0~OG7: Odd pixel G data

OB0~OB7: Odd pixel B data

DE: Data enable signal

DCLK: Data clock signal

Note (1) The system must have the transmitter to drive the module.

Note (2) LVDS cable impedance shall be 50 ohms per signal line or about 100 ohms per twist-pair line when it is used differentially.

Note (3) Two pixel data send into the module for every clock cycle. The first pixel of the frame is odd pixel and the second pixel is even pixel.

5.5 LVDS INTERFACE

VESA LVDS format : (SELLVDS pin=H)

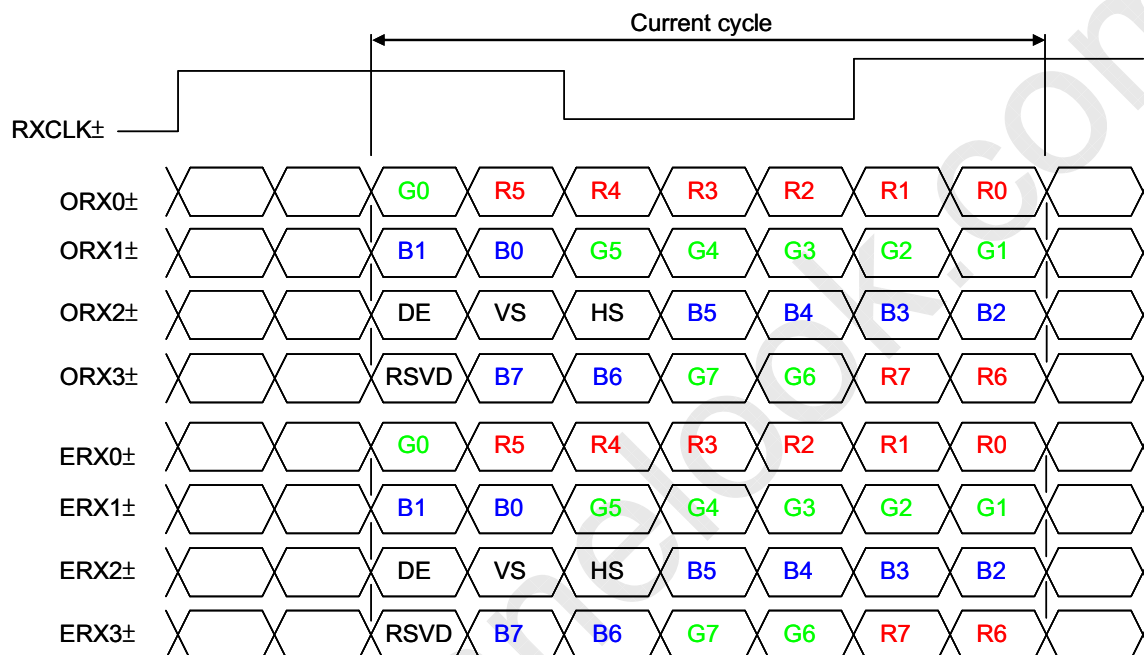

JEDIA LVDS format : (SELLVDS pin=L)

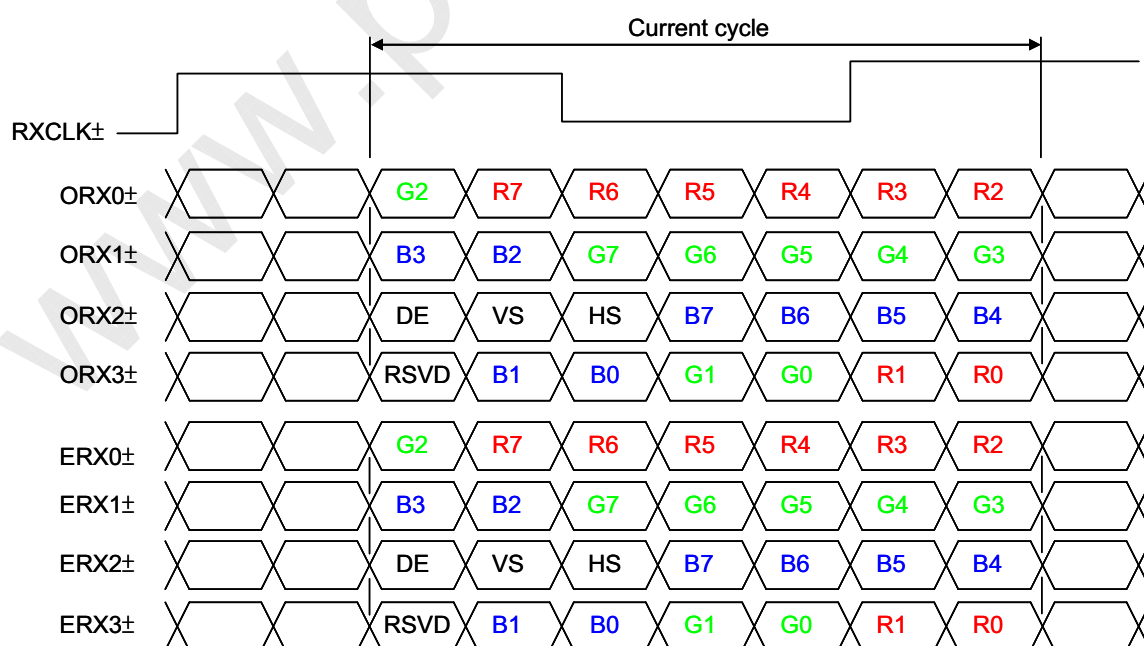

R0~R7: Pixel R Data (7; MSB, 0; LSB)

G0~G7: Pixel G Data (7; MSB, 0; LSB)

B0~B7: Pixel B Data (7; MSB, 0; LSB)

DE : Data enable signal

DCLK : Data clock signal

Notes: (1) RSVD (reserved) pins on the transmitter shall be "H" or "L".

5.6 COLOR DATA INPUT ASSIGNMENT

The brightness of each primary color (red, green and blue) is based on the 8-bit gray scale data input for the color. The higher the binary input, the brighter the color. The table below provides the assignment of the color versus data input.

Color		Data Signal																							
		Red								Green								Blue							
		R7	R6	R5	R4	R3	R2	R1	R0	G7	G6	G5	G4	G3	G2	G1	G0	B7	B6	B5	B4	B3	B2	B1	B0
Basic Colors	Black	0	0	0	0	0	0	0	0	0	0	0	0	0	0	0	0	0	0	0	0	0	0	0	0
	Red	1	1	1	1	1	1	1	1	0	0	0	0	0	0	0	0	0	0	0	0	0	0	0	0
	Green	0	0	0	0	0	0	0	0	1	1	1	1	1	1	1	1	0	0	0	0	0	0	0	0
	Blue	0	0	0	0	0	0	0	0	0	0	0	0	0	0	0	0	1	1	1	1	1	1	1	1
	Cyan	0	0	0	0	0	0	0	0	1	1	1	1	1	1	1	1	1	1	1	1	1	1	1	1
	Magenta	1	1	1	1	1	1	1	1	0	0	0	0	0	0	0	0	1	1	1	1	1	1	1	1
	Yellow	1	1	1	1	1	1	1	1	1	1	1	1	1	1	1	1	0	0	0	0	0	0	0	0
	White	1	1	1	1	1	1	1	1	1	1	1	1	1	1	1	1	1	1	1	1	1	1	1	1
Gray Scale Of Red	Red (0) / Dark	0	0	0	0	0	0	0	0	0	0	0	0	0	0	0	0	0	0	0	0	0	0	0	0
	Red (1)	0	0	0	0	0	0	0	1	0	0	0	0	0	0	0	0	0	0	0	0	0	0	0	0
	Red (2)	0	0	0	0	0	0	1	0	0	0	0	0	0	0	0	0	0	0	0	0	0	0	0	0
	⋮	⋮	⋮	⋮	⋮	⋮	⋮	⋮	⋮	⋮	⋮	⋮	⋮	⋮	⋮	⋮	⋮	⋮	⋮	⋮	⋮	⋮	⋮	⋮	⋮
	⋮	⋮	⋮	⋮	⋮	⋮	⋮	⋮	⋮	⋮	⋮	⋮	⋮	⋮	⋮	⋮	⋮	⋮	⋮	⋮	⋮	⋮	⋮	⋮	⋮
	Red (253)	1	1	1	1	1	1	0	1	0	0	0	0	0	0	0	0	0	0	0	0	0	0	0	0
	Red (254)	1	1	1	1	1	1	1	0	0	0	0	0	0	0	0	0	0	0	0	0	0	0	0	0
	Red (255)	1	1	1	1	1	1	1	1	0	0	0	0	0	0	0	0	0	0	0	0	0	0	0	0
Gray Scale Of Green	Green (0) / Dark	0	0	0	0	0	0	0	0	0	0	0	0	0	0	0	0	0	0	0	0	0	0	0	0
	Green (1)	0	0	0	0	0	0	0	0	0	0	0	0	0	0	0	1	0	0	0	0	0	0	0	0
	Green (2)	0	0	0	0	0	0	0	0	0	0	0	0	0	0	1	0	0	0	0	0	0	0	0	0
	⋮	⋮	⋮	⋮	⋮	⋮	⋮	⋮	⋮	⋮	⋮	⋮	⋮	⋮	⋮	⋮	⋮	⋮	⋮	⋮	⋮	⋮	⋮	⋮	⋮
	⋮	⋮	⋮	⋮	⋮	⋮	⋮	⋮	⋮	⋮	⋮	⋮	⋮	⋮	⋮	⋮	⋮	⋮	⋮	⋮	⋮	⋮	⋮	⋮	⋮
	Green (253)	0	0	0	0	0	0	0	0	1	1	1	1	1	1	0	1	0	0	0	0	0	0	0	0
	Green (254)	0	0	0	0	0	0	0	0	1	1	1	1	1	1	1	0	0	0	0	0	0	0	0	0
	Green (255)	0	0	0	0	0	0	0	0	1	1	1	1	1	1	1	1	0	0	0	0	0	0	0	0
Gray Scale Of Blue	Blue (0) / Dark	0	0	0	0	0	0	0	0	0	0	0	0	0	0	0	0	0	0	0	0	0	0	0	0
	Blue (1)	0	0	0	0	0	0	0	0	0	0	0	0	0	0	0	0	0	0	0	0	0	0	0	1
	Blue (2)	0	0	0	0	0	0	0	0	0	0	0	0	0	0	0	0	0	0	0	0	0	0	1	0
	⋮	⋮	⋮	⋮	⋮	⋮	⋮	⋮	⋮	⋮	⋮	⋮	⋮	⋮	⋮	⋮	⋮	⋮	⋮	⋮	⋮	⋮	⋮	⋮	⋮
	⋮	⋮	⋮	⋮	⋮	⋮	⋮	⋮	⋮	⋮	⋮	⋮	⋮	⋮	⋮	⋮	⋮	⋮	⋮	⋮	⋮	⋮	⋮	⋮	⋮
	Blue (253)	0	0	0	0	0	0	0	0	0	0	0	0	0	0	0	0	1	1	1	1	1	1	0	1
	Blue (254)	0	0	0	0	0	0	0	0	0	0	0	0	0	0	0	0	1	1	1	1	1	1	1	0
	Blue (255)	0	0	0	0	0	0	0	0	0	0	0	0	0	0	0	0	1	1	1	1	1	1	1	1

Note (1) 0: Low Level Voltage, 1: High Level Voltage

6. INTERFACE TIMING

6.1 INPUT SIGNAL TIMING SPECIFICATIONS

(Ta = 25 ± 2 °C)

The input signal timing specifications are shown as the following table and timing diagram.

Signal	Item	Symbol	Min.	Typ.	Max.	Unit	Note
LVDS Receiver Clock	Frequency	F_{clkin} (=1/TC)	60	74.25	80	MHz	
	Input cycle to cycle jitter	T_{rcj}	—	—	200	ps	(2)
	Spread spectrum modulation range	F_{clkin_mod}	$F_{clkin}-2\%$	—	$F_{clkin}+2\%$	MHz	(3)
	Spread spectrum modulation frequency	F_{SSM}	—	—	200	KHz	
LVDS Receiver Data	Setup Time	$Tlvsu$	600	—	—	ps	
	Hold Time	$Tlvhd$	600	—	—	ps	
Vertical Active Display Term	Frame Rate	F_{r5}	47	50	53	Hz	
		F_{r6}	57	60	63	Hz	
	Total	Tv	1090	1125	1480	Th	$Tv=Tvd+Tvb$
	Display	Tvd	1080	1080	1080	Th	
	Blank	Tvb	10	45	400	Th	
Horizontal Active Display Term	Total	Th	1030	1100	1325	Tc	$Th=Thd+Thb$
	Display	Thd	960	960	960	Tc	
	Blank	Thb	70	140	365	Tc	

Note (1) Please make sure the range of frame rate has follow the below equation :

$$F_{clkin(max)} \geq Fr6 \times Tv \times Th$$

$$Fr5 \times Tv \times Th \geq F_{clkin(min)}$$

Note (2) This module is operated in DE only mode and please follow the input signal timing diagram below :

INPUT SIGNAL TIMING DIAGRAM

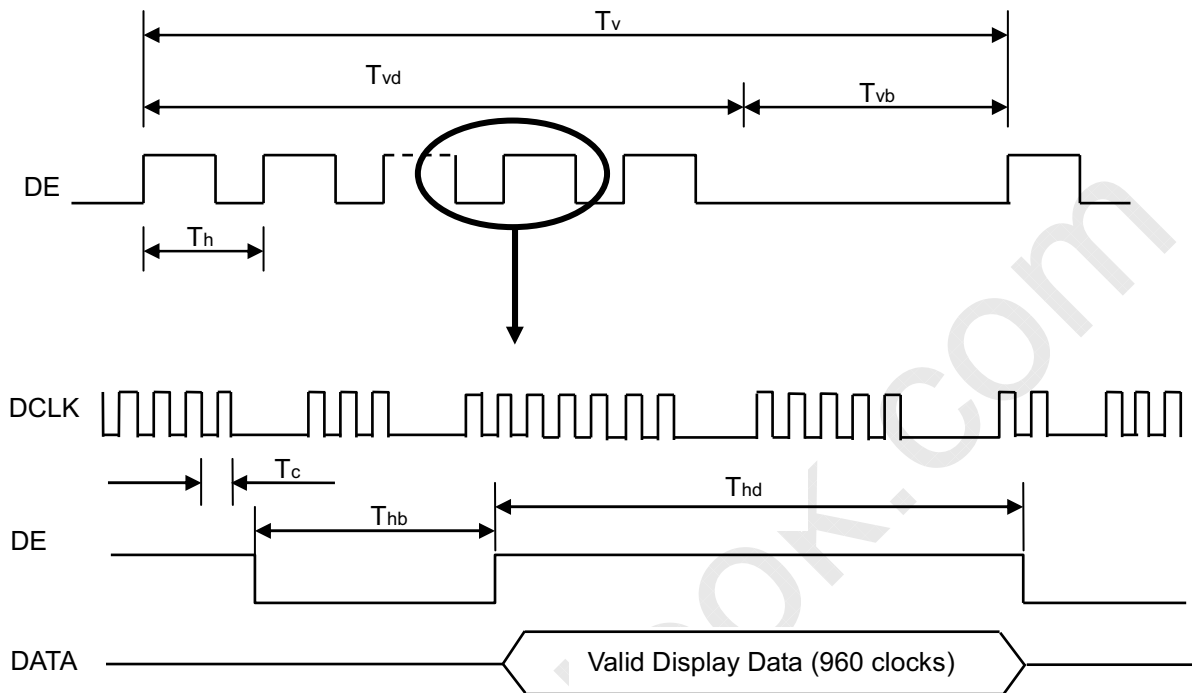

Note (3) The input clock cycle-to-cycle jitter is defined as below figures. $Trcl = |T_1 - T_1|$

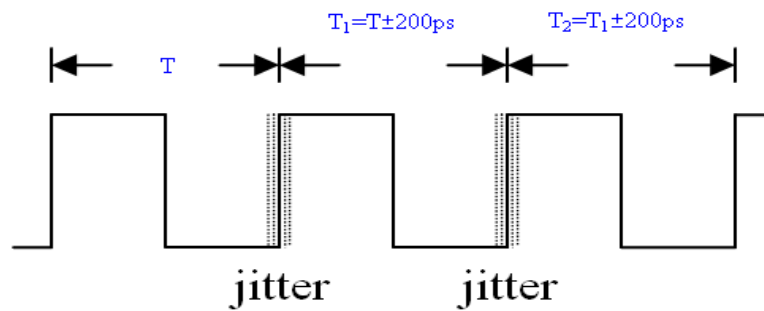

Note (4) The SSCG (Spread spectrum clock generator) is defined as below figures.

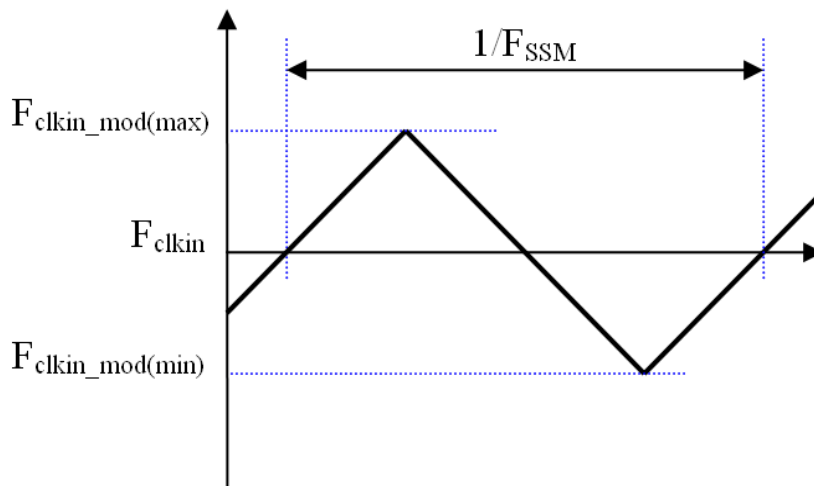

Note (5) The LVDS timing diagram and setup/hold time is defined and showing as the following figures.

LVDS RECEIVER INTERFACE TIMING DIAGRAM

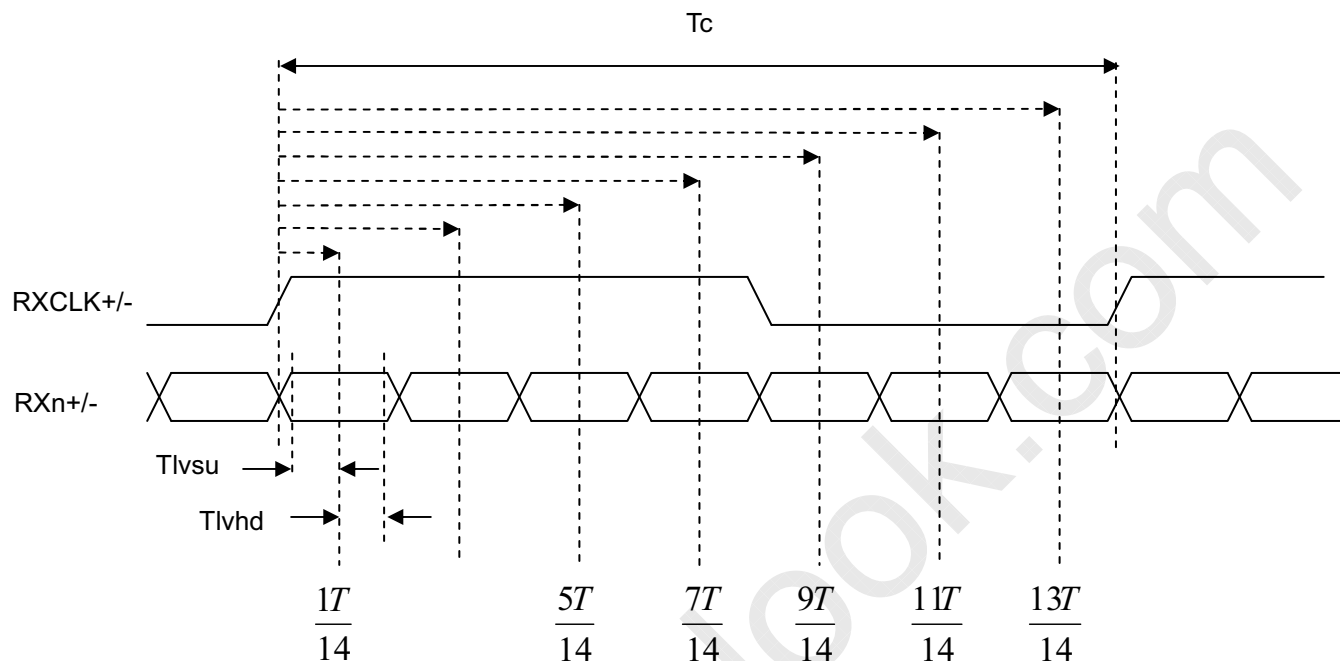

Note (6) : (ODSEL) = H/L for 60/60Hz frame rate. Please refer to 5.1 for detail information

6.2 POWER ON/OFF SEQUENCE

($T_a = 25 \pm 2 \text{ } ^\circ\text{C}$)

To prevent a latch-up or DC operation of LCD module, the power on/off sequence should be as the diagram below.

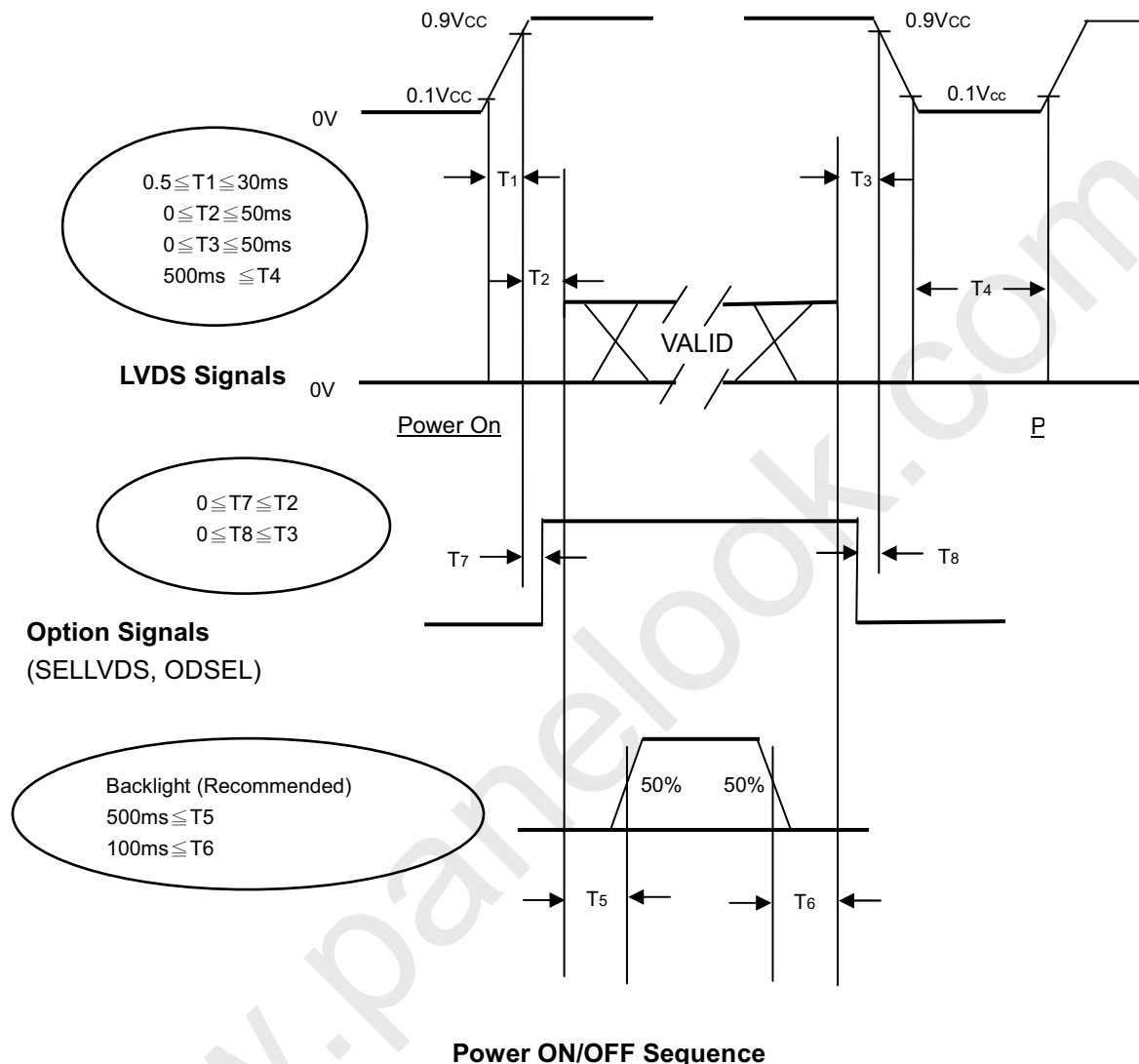

Note (1) The supply voltage of the external system for the module input should follow the definition of V_{cc} .

Note (2) Apply the lamp voltage within the LCD operation range. When the backlight turns on before the LCD operation or the LCD turns off before the backlight turns off, the display may momentarily become abnormal screen.

Note (3) In case of V_{CC} is in off level, please keep the level of input signals on the low or high impedance.

Note (4) $T4$ should be measured after the module has been fully discharged between power off and on period.

Note (5) Interface signal shall not be kept at high impedance when the power is on.

7. OPTICAL CHARACTERISTICS

7.1 TEST CONDITIONS

Item	Symbol	Value	Unit
Ambient Temperature	Ta	25±2	°C
Ambient Humidity	Ha	50±10	%RH
Supply Voltage	VCC	12	V
Input Signal	According to typical value in "3. ELECTRICAL CHARACTERISTICS"		
Lamp Current	IL	12.3	mA
Oscillating Frequency (Inverter)	FW	58	KHz
Vertical Frame Rate	Fr	60	Hz

The LCD module should be stabilized at given temperature for 1 hour to avoid abrupt temperature change during measuring in a windless room.

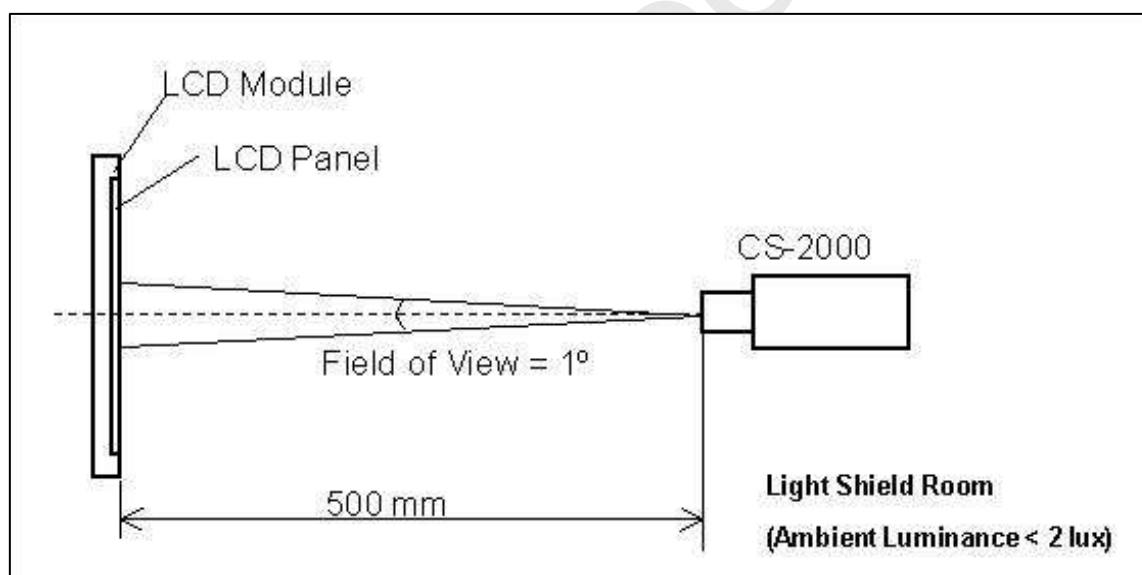

7.2 OPTICAL SPECIFICATIONS

The relative measurement methods of optical characteristics are shown in 7.2. The following items should be measured under the test conditions described in 7.1 and stable environment shown in 7.1.

Item		Symbol	Condition	Min.	Typ.	Max.	Unit	Note				
Contrast Ratio		CR		3500	5000	-	-	(2)				
Response Time		Gray to gray		-	8.5	17	ms	(3)				
Center Luminance of White		L_c		320	400	-	cd/m ²	(4)				
White Variation		δW		-	-	1.3	-	(6)				
Cross Talk		CT		-	-	4.0	%	(5)				
Color Chromaticity	Red	Rx		$\theta_x=0^\circ, \theta_y=0^\circ$ Viewing angle at normal direction	Typ -0.03	0.633	Typ +0.03	-	-			
		Ry	0.322			-						
	Green	Gx	0.290			-						
		Gy	0.600			-						
	Blue	Bx	0.148			-						
		By	0.048			-						
	White	Wx	0.280			-						
		Wy	0.290			-						
	Color Gamut		C.G			-		72		-	%	NTSC
	Viewing Angle	Horizontal	θ_{x+}			CR \geq 20				88	Deg.	(1)
θ_{x-}			88									
Vertical		θ_{Y+}	88									
		θ_{Y-}	88									

Note (1) Definition of Viewing Angle (θ_x, θ_y):

Viewing angles are measured by Conoscope Cono-80 (or Eldim EZ-Contrast 160R)

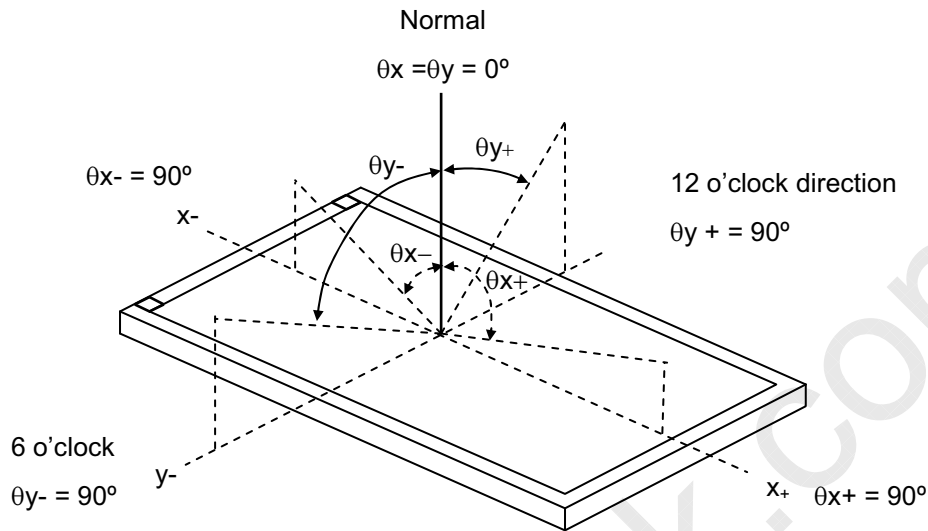

Note (2) Definition of Contrast Ratio (CR):

The contrast ratio can be calculated by the following expression.

$$\text{Contrast Ratio (CR)} = \frac{\text{Surface Luminance of L255}}{\text{Surface Luminance of L0}}$$

L255: Luminance of gray level 255

L 0: Luminance of gray level 0

CR = CR (5), where CR (X) is corresponding to the Contrast Ratio of the point X at the figure in Note (6).

Note (3) Definition of Gray-to-Gray Switching Time:

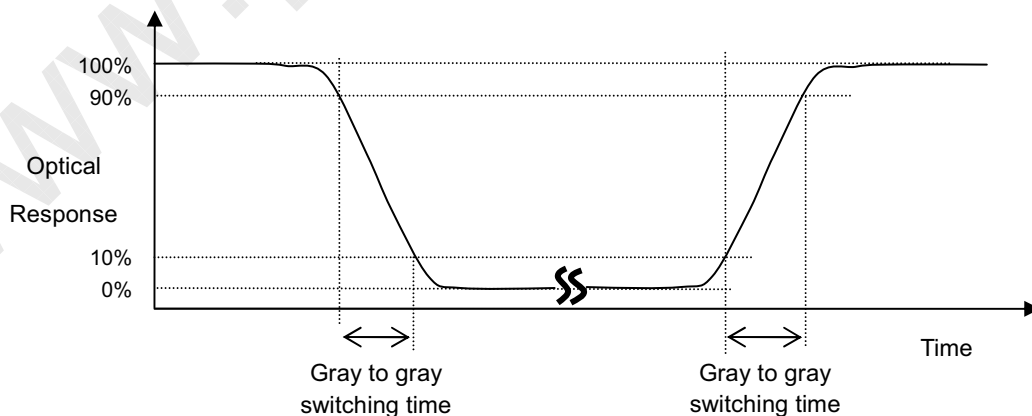

The driving signal means the signal of gray level 0, 31, 63, 95, 127, 159, 191, 223, 255.

Gray to gray average time means the average switching time of gray level 0, 31, 63, 95, 127, 159, 191,

223, 255. to each other.

Note (4) Definition of Luminance of White (L_C):

Measure the luminance of gray level 255 at center point and 5 points

$L_C = L(5)$, where $L(X)$ is corresponding to the luminance of the point X at the figure in Note (6).

Note (5) Definition of Cross Talk (CT):

$$CT = |Y_B - Y_A| / Y_A \times 100 (\%)$$

Where:

Y_A = Luminance of measured location without gray level 255 pattern (cd/m²)

Y_B = Luminance of measured location with gray level 255 pattern (cd/m²)

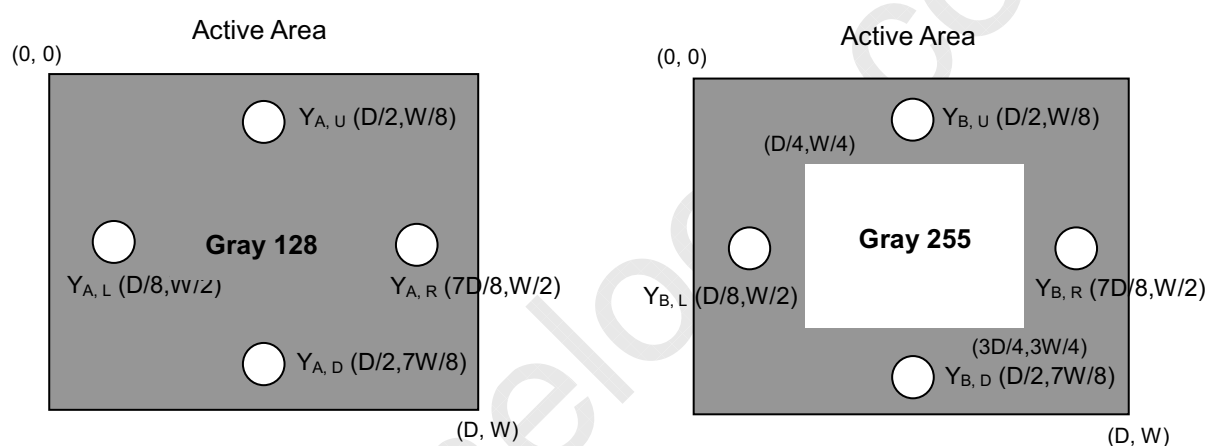

Note (6) Definition of White Variation (δW):

Measure the luminance of gray level 255 at 5 points

$$\delta W = \text{Maximum} [L(1), L(2), L(3), L(4), L(5)] / \text{Minimum} [L(1), L(2), L(3), L(4), L(5)]$$

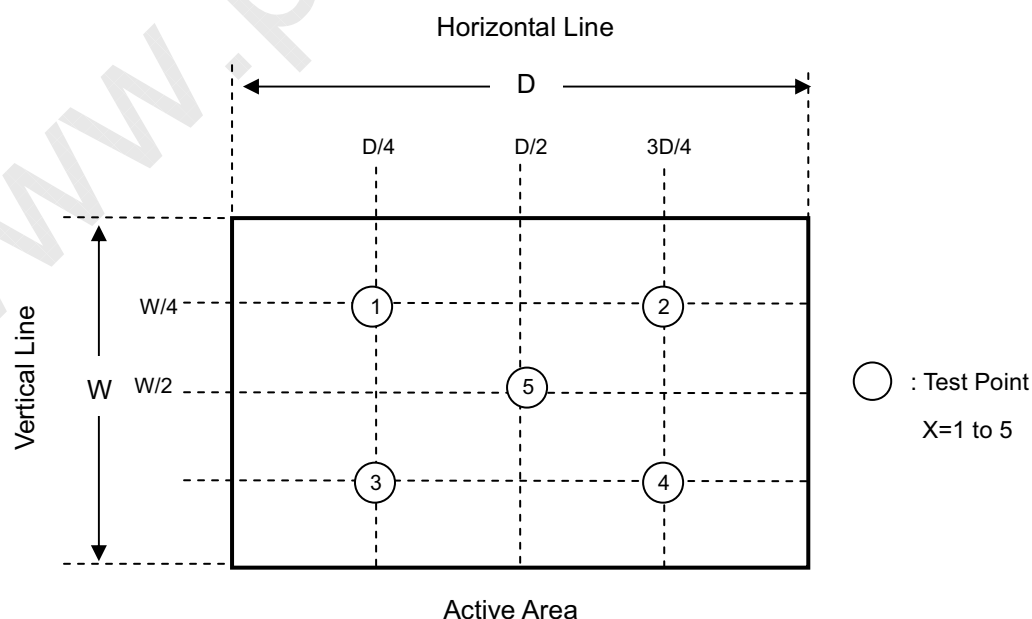

8. PRECAUTIONS

8.1 ASSEMBLY AND HANDLING PRECAUTIONS

- [1] Do not apply rough force such as bending or twisting to the module during assembly.
- [2] It is recommended to assemble or to install a module into the user's system in clean working areas. The dust and oil may cause electrical short or worsen the polarizer.
- [3] Do not apply pressure or impulse to the module to prevent the damage of LCD panel and Backlight.
- [4] Always follow the correct power-on sequence when the LCD module is turned on. This can prevent the damage and latch-up of the CMIS LSI chips.
- [5] Bezel of Set can not press or touch the panel surface. It will make light leakage or scrape.
- [6] Do not plug in or pull out the I/F connector while the module is in operation.
- [7] Do not disassemble the module.
- [8] Use a soft dry cloth without chemicals for cleaning, because the surface of polarizer is very soft and easily scratched.
- [9] Moisture can easily penetrate into LCD module and may cause the damage during operation.
- [10] When storing modules as spares for a long time, the following precaution is necessary.
 - [10.1] Do not leave the module in high temperature, and high humidity for a long time. It is highly recommended to store the module with temperature from 0 to 35°C at normal humidity without condensation.
 - [10.2] The module shall be stored in dark place. Do not store the TFT-LCD module in direct sunlight or fluorescent light.
- [11] When ambient temperature is lower than 10°C, the display quality might be reduced. For example, the response time will become slow, and the starting voltage of CCFL will be higher than that of room temperature.

8.2 SAFETY PRECAUTIONS

- [1] The startup voltage of a Backlight is approximately 1000 Volts. It may cause an electrical shock while assembling with the inverter. Do not disassemble the module or insert anything into the Backlight unit.
- [2] If the liquid crystal material leaks from the panel, it should be kept away from the eyes or mouth. In case of contact with hands, skin or clothes, it has to be washed away thoroughly with soap.
- [3] After the module's end of life, it is not harmful in case of normal operation and storage.

9. DEFINITION OF LABELS
9.1 CMI MODULE LABEL

The barcode nameplate is pasted on each module as illustration, and its definitions are as following explanation.

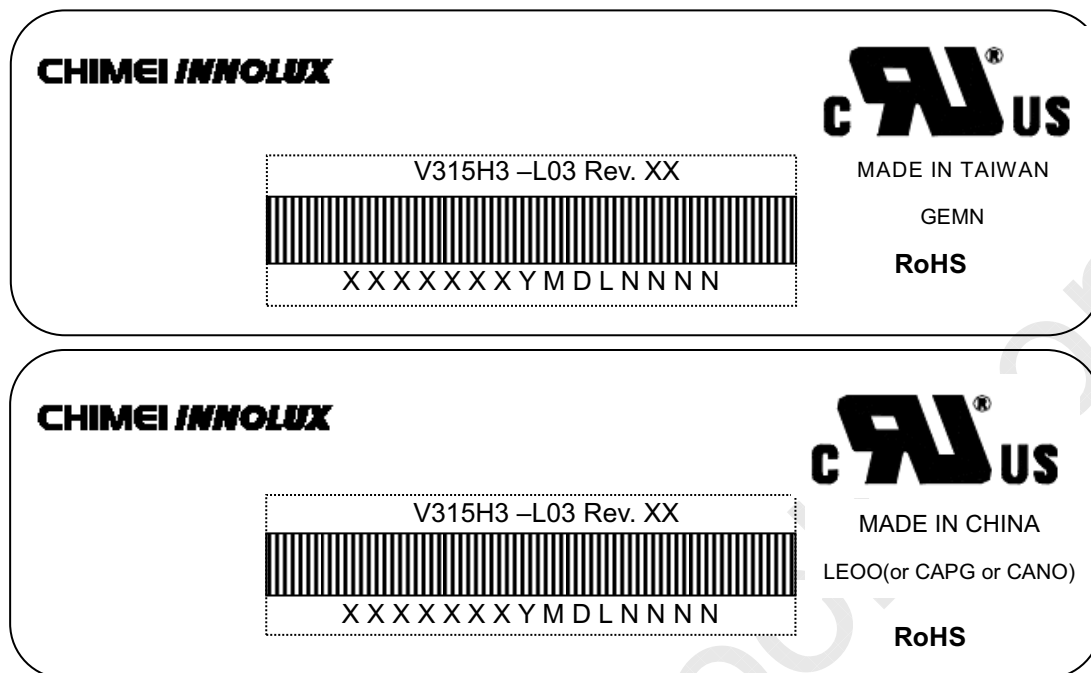

Model Name: V315H3-L03

Revision: Rev. XX, for example: A0, A1... B1, B2... or C1, C2...etc.

Serial ID: X X X X X X Y M D L N N N N

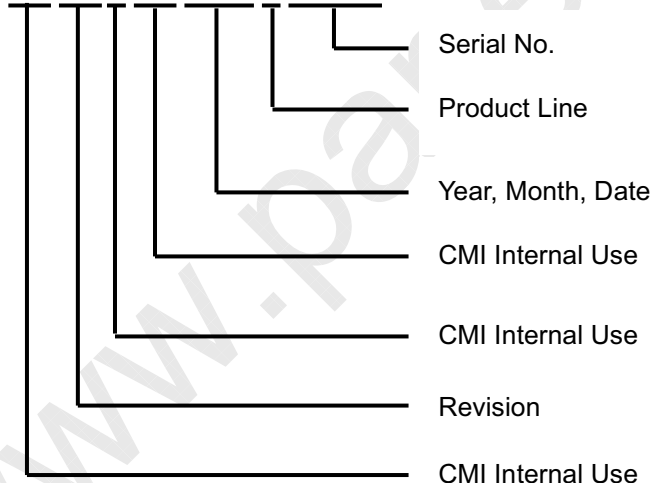

Serial ID includes the information as below:

Manufactured Date:

Year : 2001=1, 2002=2, 2003=3, 2004=4...2010=0, 2011=1, 2012=2...

Month: 1~9, A~C, for Jan. ~ Dec.

Day: 1~9, A~Y, for 1st to 31st, exclude I, O, and U.

Revision Code : Cover all the change

Serial No. : Manufacturing sequence of product

Product Line : 1 → Line1, 2 → Line 2, ...etc.

10. PACKAGING

10.1 PACKAGING SPECIFICATIONS

- (1) 5 LCD TV modules / 1 Box
- (2) Box dimensions : 826(L)x376(W)x540(H)mm
- (3) Weight : approximately 30.1 Kg (5 modules per box)

10.2 PACKAGING METHOD

Figures 10-1 and 10-2 are the packing method

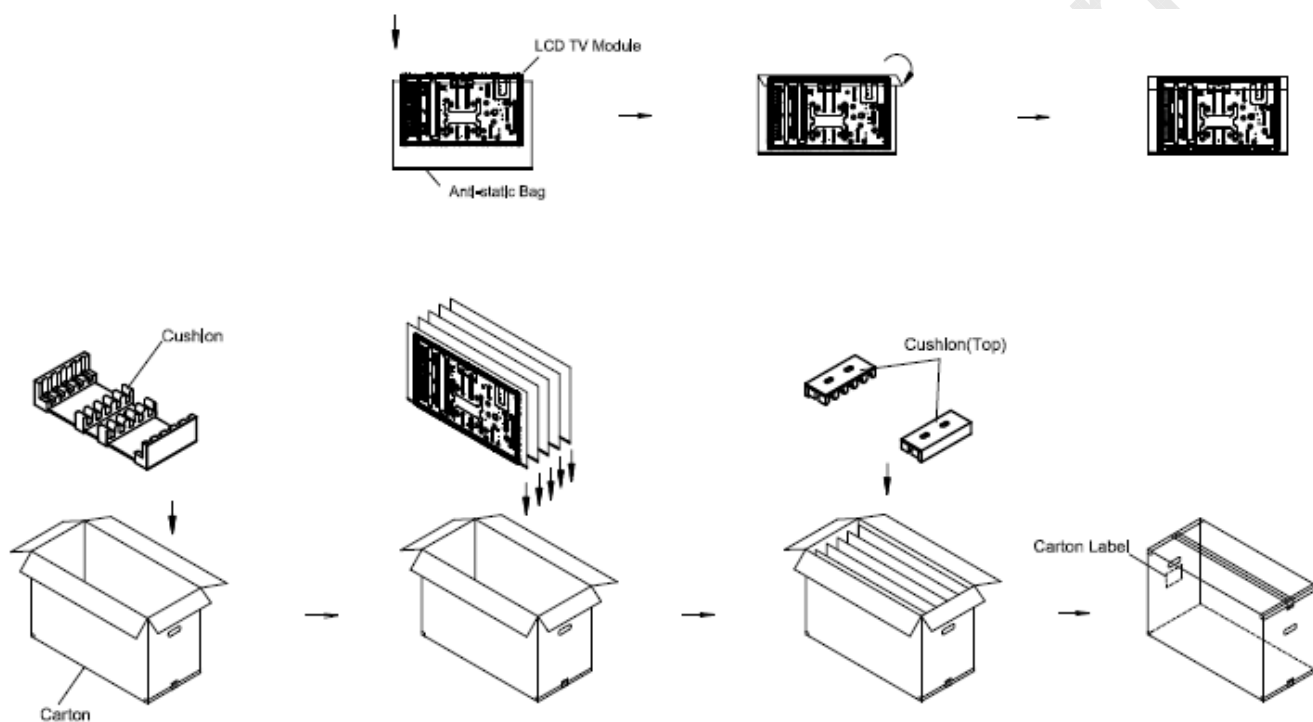
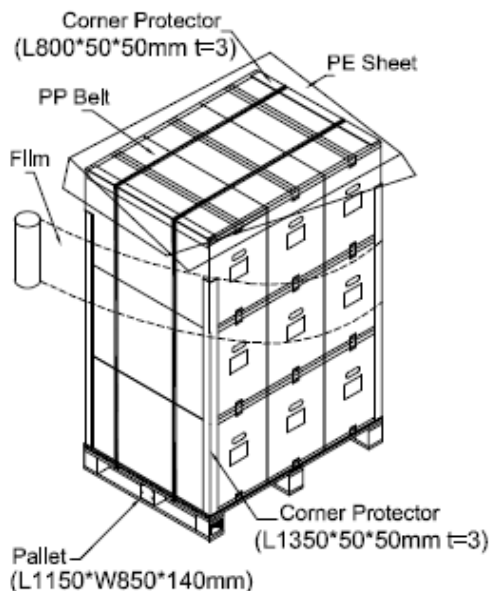
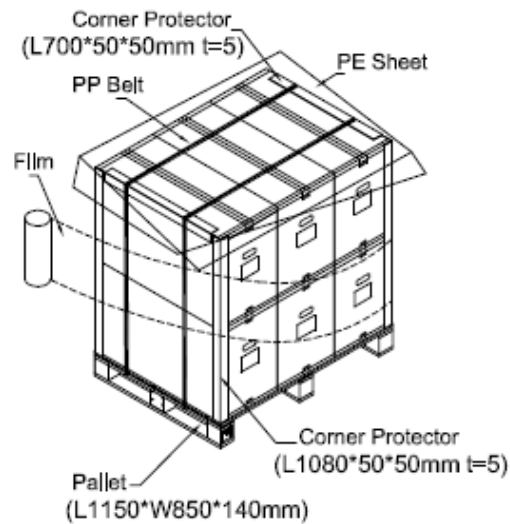

Figure 10-1 packing method

Sea / Land Transportation (40ft Container)



Air Transportation



Sea / Land Transportaⁿ (40ft HQ Container)

Figure 10-2 packing method

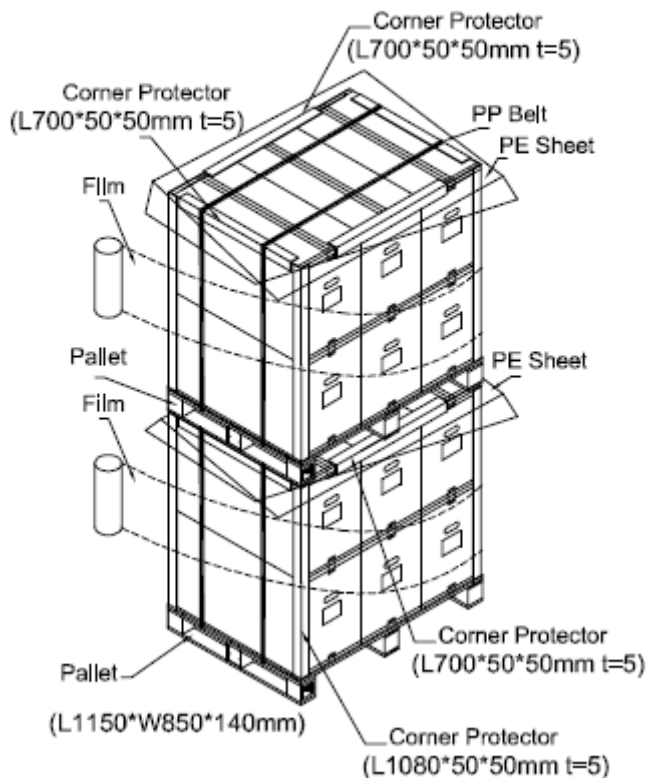

11. MECHANICAL CHARACTERISTIC

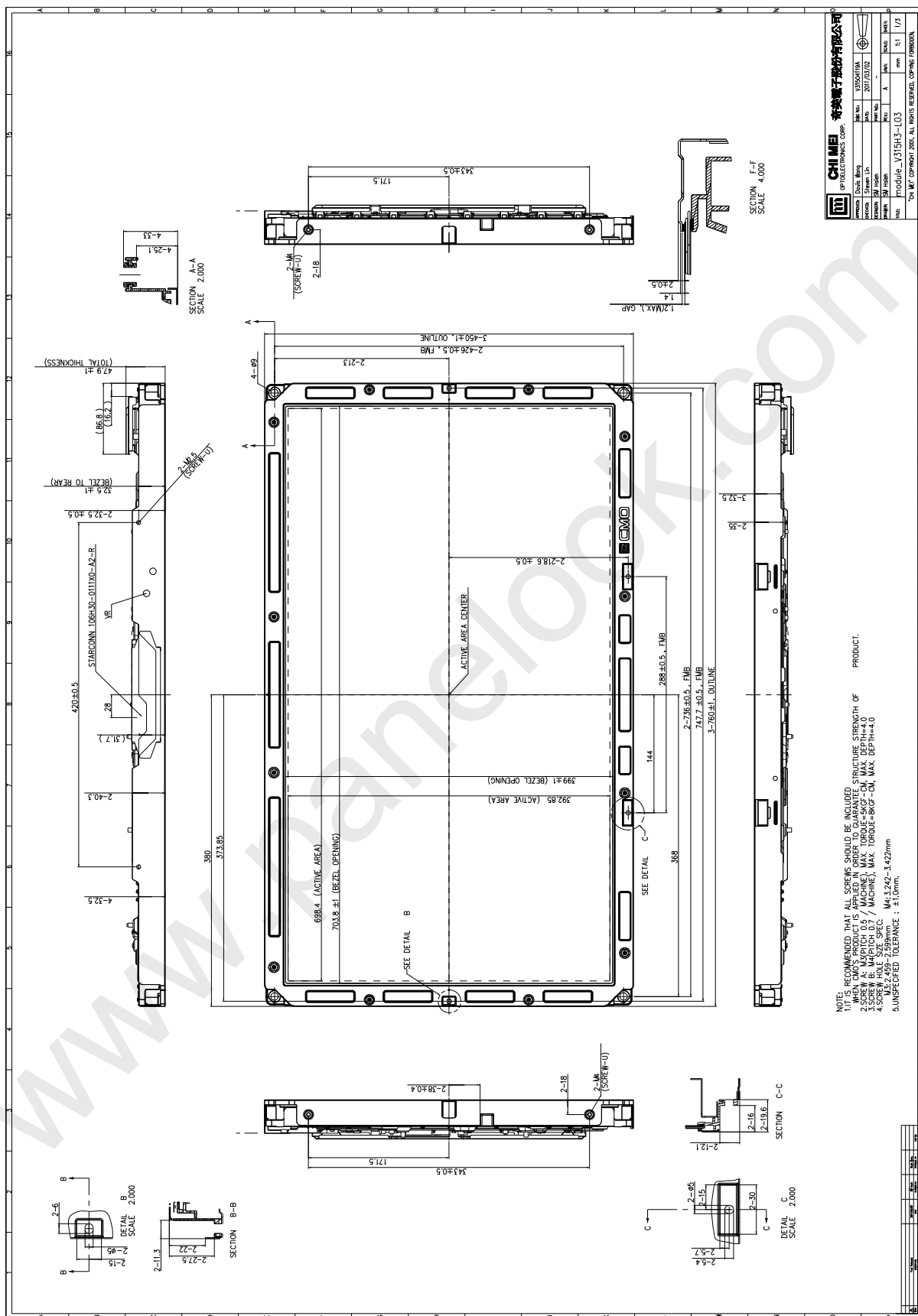

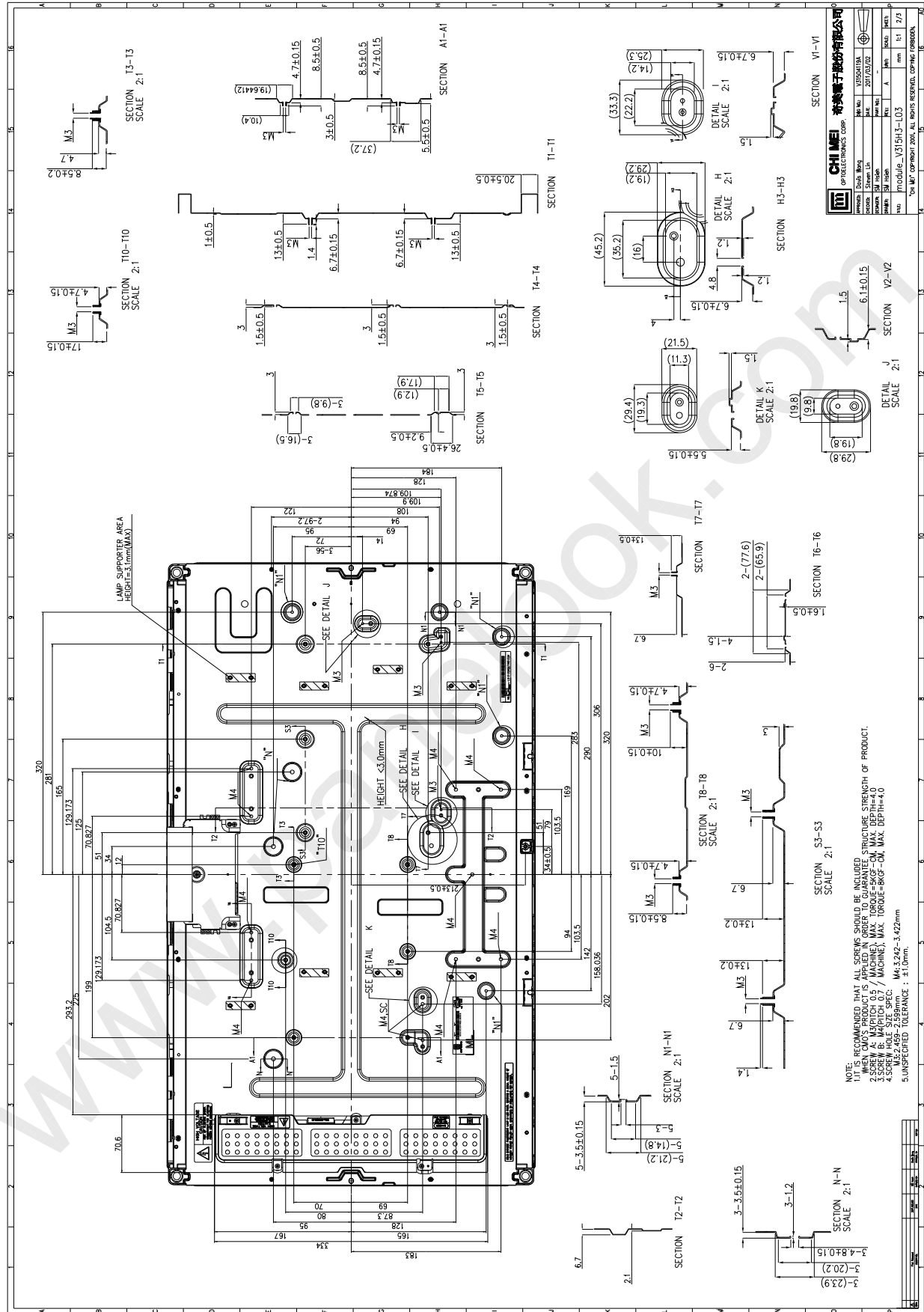

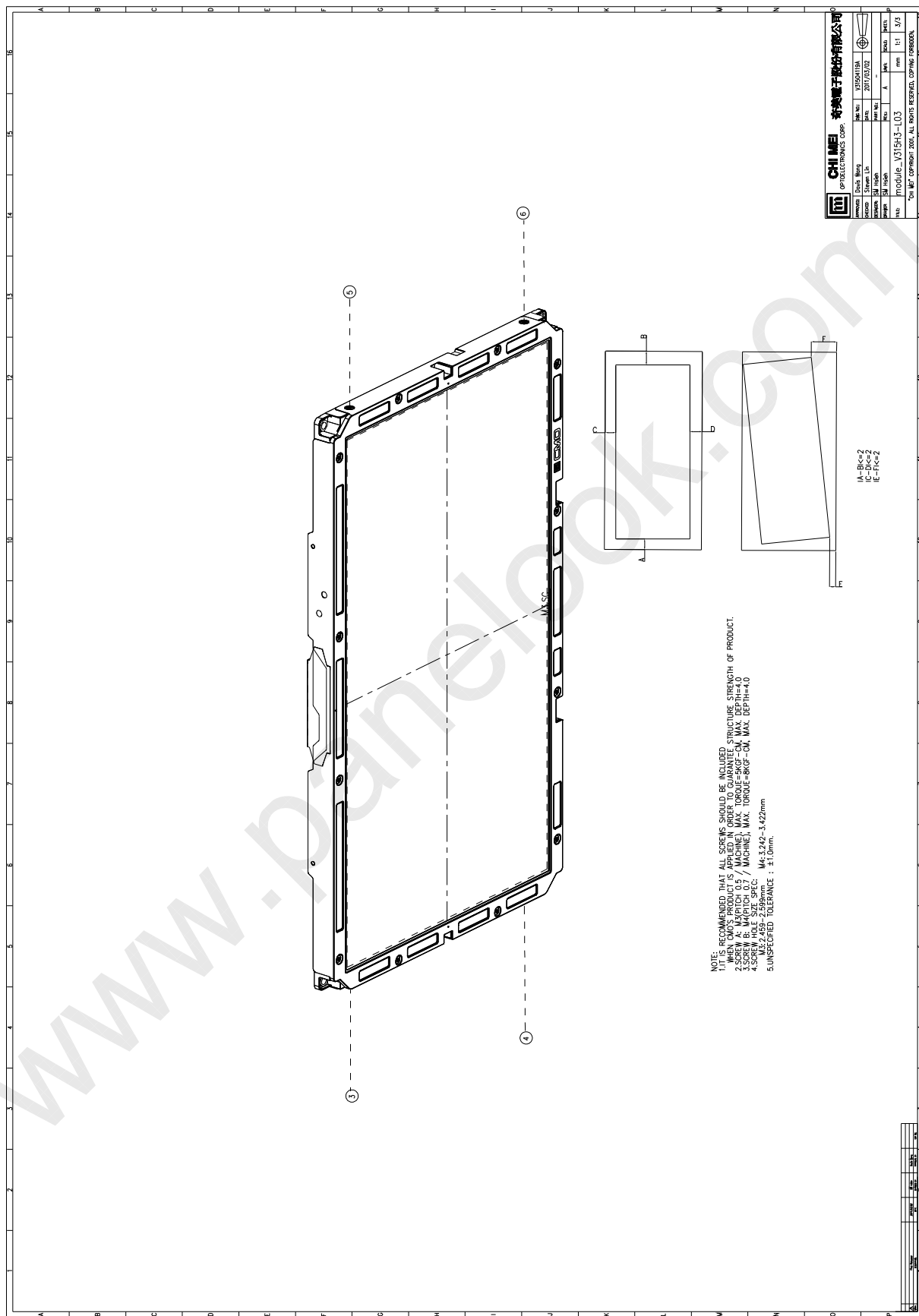

www.panelook.com