

- Tentative Specification
 Preliminary Specification
 Approval Specification

MODEL NO.: V315H3
SUFFIX: LE8

Customer:	
APPROVED BY	SIGNATURE
Name / Title _____	_____
Note	

Please return 1 copy for your confirmation with your	

Approved By	Checked By	Prepared By
Chao-Chun Chung	Vincent Chou	Archer Chang

CONTENTS

1. GENERAL DESCRIPTION	5
1.1 OVERVIEW	5
1.2 FEATURES	5
1.3 APPLICATION	5
1.4 GENERAL SPECIFICATIONS	5
1.5 MECHANICAL SPECIFICATIONS	6
2. ABSOLUTE MAXIMUM RATINGS	7
2.1 ABSOLUTE RATINGS OF ENVIRONMENT	7
2.2 PACKAGE STORAGE	8
2.3 ELECTRICAL ABSOLUTE RATINGS	8
2.3.1 TFT LCD MODULE	8
2.3.2 BACKLIGHT CONVERTER UNIT	8
3. ELECTRICAL CHARACTERISTICS	9
3.1 TFT LCD MODULE	9
3.2 BACKLIGHT CONVERTER UNIT	12
4. BLOCK DIAGRAM OF INTERFACE	15
4.1 TFT LCD MODULE	15
5. INPUT TERMINAL PIN ASSIGNMENT	16
5.1 TFT LCD Module Input	16
5.2 BACKLIGHT UNIT	20
5.3 CONVERTER UNIT	20
5.4 BLOCK DIAGRAM OF INTERFACE	22
5.5 LVDS INTERFACE	24
5.6 COLOR DATA INPUT ASSIGNMENT	25
6. INTERFACE TIMING	26
6.1 INPUT SIGNAL TIMING SPECIFICATIONS	26
6.2 POWER ON/OFF SEQUENCE	29
7. OPTICAL CHARACTERISTICS	30
7.1 TEST CONDITIONS	30
7.2 OPTICAL SPECIFICATIONS	31



PRODUCT SPECIFICATION

8 PRECAUTIONS	35
8.1 ASSEMBLY AND HANDLING PRECAUTIONS	35
8.2 SAFETY PRECAUTIONS	35
9. DEFINITION OF LABELS	36
9.1 CMI MODULE LABEL	36
10. PACKAGING	37
10.1 PACKAGING SPECIFICATIONS	37
10.2 PACKAGING METHOD	37
11. INTERNATIONAL STANDARD	39
11.1 SAFETY	39
11.2 EMC	39
12. MECHANICAL CHARACTERISTIC	40

REVISION HISTORY

Version	Date	Page(New)	Section	Description
Ver. 2.0	Dec. 30, 2010	All	All	The Approval Specification was first issued.
Ver. 2.1	Feb. 31, 2011	NA	Appendix	Cancel Appendix
	Mar. 09, 2011	9	3.1	Modify TFT LCD Module-Power Consumption/Power Supply Current
		33	7.2	Cancel Double Note(3)
		33	7.2	Modify Note(5)

1. GENERAL DESCRIPTION

1.1 OVERVIEW

V315H3-LE8 is a 31.5" TFT Liquid Crystal Display module with LED Backlight unit and 4ch-LVDS interface. This module supports 1920 x 1080 Full HDTV format and can display 1.07G (8-bit+Hi-FRC) colors. The converter module for backlight is built-in.

1.2 FEATURES

- High brightness (450 nits)
- High contrast ratio (5000:1)
- Fast response time (6.5ms)
- High color saturation (NTSC 72%)
- Full HDTV (1920 x 1080 pixels) resolution, true HDTV format
- DE (Data Enable) only mode
- LVDS (Low Voltage Differential Signaling) interface
- Optimized response time for 120 Hz frame rate
- Ultra wide viewing angle : Super MVA technology
- RoHs compliance

1.3 APPLICATION

- Standard Living Room TVs
- Public Display Application
- Home Theater Application
- MFM Application

1.4 GENERAL SPECIFICATIONS

Item	Specification	Unit	Note
Active Area	698.4 (H) x 392.85 (V)	mm	(1)
Bezel Opening Area	705.4(H) x 400 (V)	mm	
Driver Element	a-si TFT active matrix	-	-
Pixel Number	1920 x R.G.B. x 1080	pixel	-
Pixel Pitch(Sub Pixel)	0.12125 (H) x 0.36375 (V)	mm	-
Pixel Arrangement	RGB vertical stripe	-	-
Power consumption	43W	Watt	(2)
Display Colors	1.07G	color	-
Display Operation Mode	Transmissive mode / Normally Black	-	-
Surface Treatment	Anti-Glare coating (Haze 11%)	-	(3)

Note (1) Please refer to the attached drawings in chapter 9 for more information about the front and back outlines.

Note (2) Please refer sec 3.1 and 3.2 for more information of Power consumption

Note (3) The spec. of the surface treatment is temporarily for this phase. CMI reserves the rights to change this feature.

1.5 MECHANICAL SPECIFICATIONS

Item		Min.	Typ.	Max.	Unit	Note
Module Size	Horizontal (H)	734.4	735.4	736.4	mm	(1)
	Vertical (V)	432	433	434	mm	(1)
	Depth (D)	9.8	10.8	11.8	mm	(2)
	Depth (D)	30.7	31.7	32.7	mm	(3)
Weight		-	4300	-	g	-

Note (1) Please refer to the attached drawings for more information of front and back outline dimensions.

Note (2) Module Depth is between bezel to T-CON cover.

Note (3) Module Depth is between bezel to converter cover.

2. ABSOLUTE MAXIMUM RATINGS

2.1 ABSOLUTE RATINGS OF ENVIRONMENT

Item	Symbol	Value		Unit	Note
		Min.	Max.		
Storage Temperature	TST	-20	+60	°C	(1)
Operating Ambient Temperature	TOP	0	50	°C	(1), (2)
Shock (Non-Operating)	SNOP	-	50	G	(3), (5)
Vibration (Non-Operating)	VNOP	-	1.0	G	(4), (5)

Note (1) Temperature and relative humidity range is shown in the figure below.

(a) 90 %RH Max. ($T_a \leq 40$ °C).

(b) Wet-bulb temperature should be 39 °C Max. ($T_a > 40$ °C).

(c) No condensation.

Note (2) The maximum operating temperature is based on the test condition that the surface temperature of display area is less than or equal to 65 °C with LCD module alone in a temperature controlled chamber. Thermal management should be considered in final product design to prevent the surface temperature of display area from being over 65 °C. The range of operating temperature may degrade in case of improper thermal management in final product design.

Note (3) 11 ms, half sine wave, 1 time for $\pm X$, $\pm Y$, $\pm Z$.

Note (4) 10 ~ 200 Hz, 10 min, 1 time each X, Y, Z.

Note (5) At testing Vibration and Shock, the fixture in holding the module has to be hard and rigid enough so that the module would not be twisted or bent by the fixture.

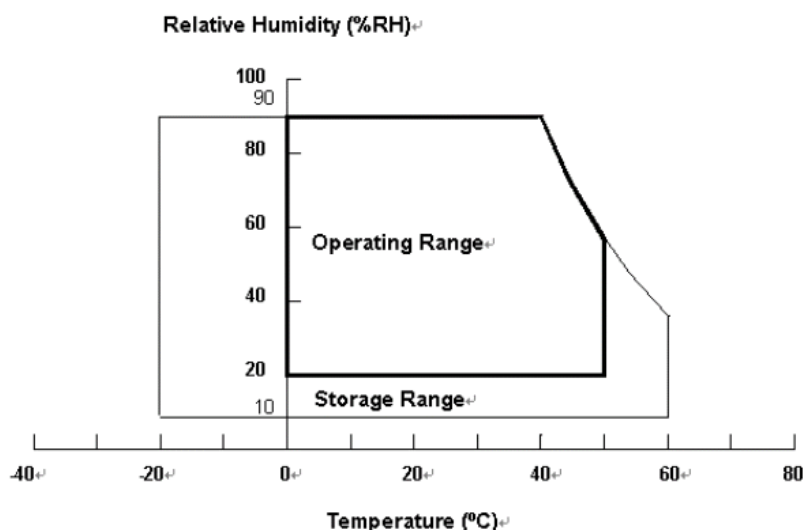

2.2 PACKAGE STORAGE

When storing modules as spares for a long time, the following precaution is necessary.

- (a) Do not leave the module in high temperature, and high humidity for a long time, It is highly recommended to store the module with temperature from 0 to 35 °C at normal humidity without condensation.
- (b) The module shall be stored in dark place. Do not store the TFT-LCD module in direct sunlight or fluorescent light.

2.3 ELECTRICAL ABSOLUTE RATINGS

2.3.1 TFT LCD MODULE

Item	Symbol	Value		Unit	Note
		Min.	Max.		
Power Supply Voltage	VCC	-0.3	13.5	V	(1)
Logic Input Voltage	VIN	-0.3	3.6	V	

2.3.2 BACKLIGHT CONVERTER UNIT

Item	Symbol	Value		Unit	Note
		Min.	Max.		
Light bar Voltage	VW	—	60	V _{DC}	
Power Supply Voltage	VBL	0	30	V	(1)
Control Signal Level	—	-0.3	7	V	(1), (3)

Note (1) Permanent damage to the device may occur if maximum values are exceeded. Function operation should be restricted to the conditions described under Normal Operating Conditions.

Note (2) No moisture condensation or freezing.

Note (3) The control signals include On/Off Control and External PWM Control.

3. ELECTRICAL CHARACTERISTICS

3.1 TFT LCD MODULE

(Ta = 25 ± 2 °C)

Parameter		Symbol	Value			Unit	Note
			Min.	Typ.	Max.		
Power Supply Voltage		V _{CC}	10.8	12	13.2	V	(1)
Rush Current		I _{RUSH}	—	—	4.836	A	(2)
Power consumption	White Pattern	—	—	5.616	6.864	W	(3)
	Horizontal Stripe	—	—	9.936	12.012	W	
	Black Pattern	—	—	5.616	6.864	W	
Power Supply Current	White Pattern	—	—	0.468	0.572	A	(4)
	Horizontal Stripe	—	—	0.828	1.001	A	
	Black Pattern	—	—	0.468	0.572	A	
LVDS interface	Differential Input High Threshold Voltage	V _{LVTH}	+100	—	—	mV	(5)
	Differential Input Low Threshold Voltage	V _{LVTL}	—	—	-100	mV	
	Common Input Voltage	V _{CM}	1.0	1.2	1.4	V	
	Differential input voltage (single-end)	V _{ID}	200	—	600	mV	
	Terminating Resistor	R _T	—	100	—	ohm	
CMIS interface	Input High Threshold Voltage	V _{IH}	2.7	—	3.3	V	
	Input Low Threshold Voltage	V _{IL}	0	—	0.7	V	

Note (1) The module should be always operated within the above ranges.

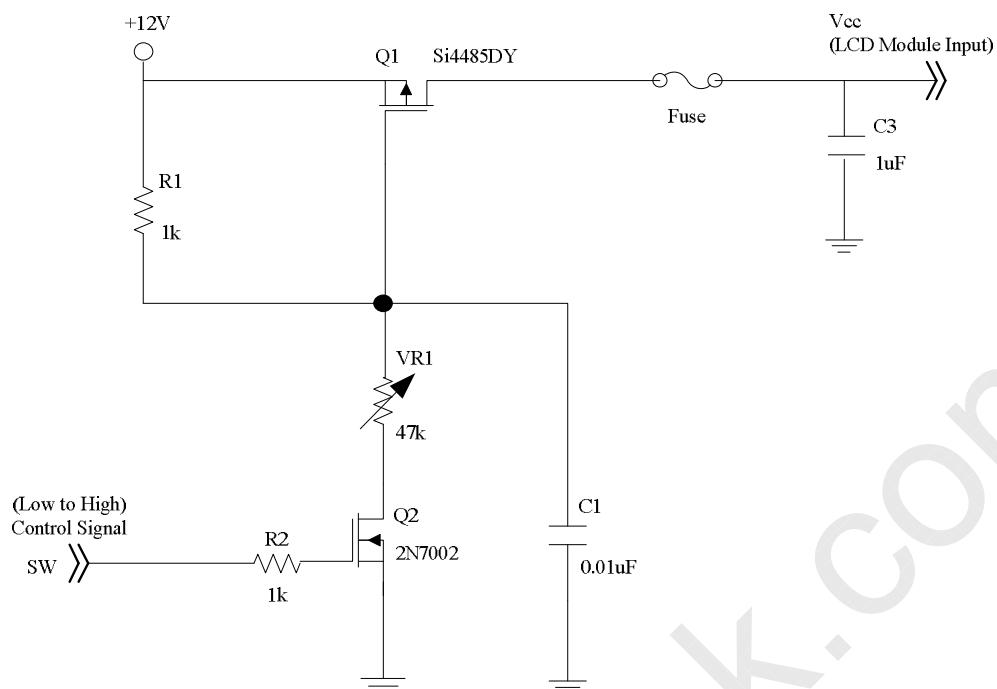

Vcc rising time is 470us

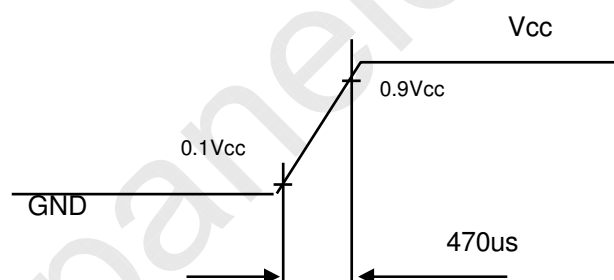

Note (3) The Specified Power consumption is under XXX pattern.

Note (4) The specified power supply current is under the conditions at $V_{cc} = 12\text{ V}$, $T_a = 25 \pm 2\text{ }^\circ\text{C}$, $f_v = 120\text{ Hz}$, whereas a power dissipation check pattern below is displayed.



a. White Pattern

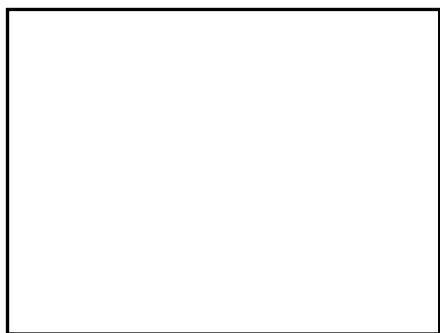

Active Area

b. Black Pattern



Active Area

c. Horizontal Pattern

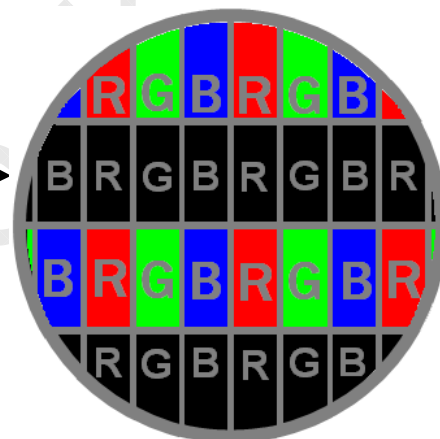
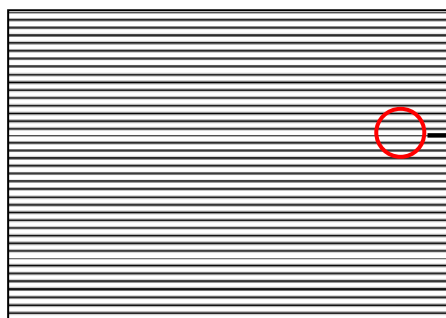

Note (4) The LVDS input characteristics are as follows :

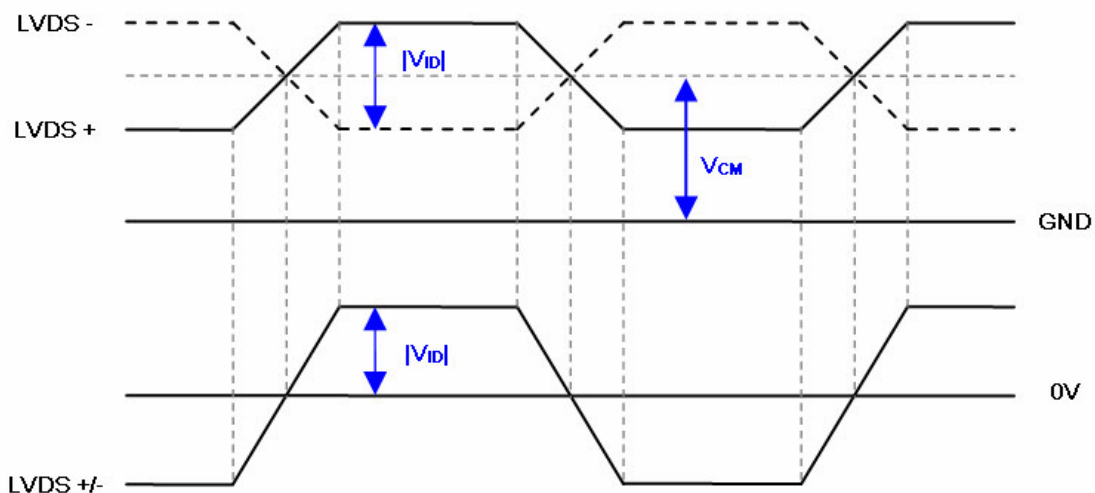

3.2 BACKLIGHT CONVERTER UNIT

3.2.1 LED LIGHT BAR CHARACTERISTICS (Ta = 25 ± 2 °C)

The backlight unit contains 2pcs light bar.

Parameter	Symbol	Value			Unit	Note
		Min.	Typ.	Max.		
Total Current (10 String)	I _f	-	960	1018	mA	
One String Current	I _L	-	120	127.2	mA	
LED Forward Voltage	V _f	2.7	3.2	3.6	V _{DC}	I _L = 120mA
One String Voltage	V _w	32.4	-	43.2	V _{DC}	I _L = 120mA
One String Voltage Variation	ΔV _w	-	-	2	V	
Life time	-	30,000	-	-	Hrs	(1)

Note (1) The lifetime is defined as the time which luminance of the LED decays to 50% compared to the initial value, Operating condition: Continuous operating at Ta = 25±2°C, I_L = 120mA.

3.2.2 CONVERTER CHARACTERISTICS (Ta = 25 ± 2 °C)

Parameter	Symbol	Value			Unit	Note
		Min.	Typ.	Max.		
Power Consumption	P _{BL}	-	41	46	W	(1),(2) I _L = 120 mA
Converter Input Voltage	V _{BL}	22.8	24	25.2	V _{DC}	
Converter Input Current	I _{BL}	-	1.7	1.92	A	Non Dimming
Input Inrush Current	-	-	-	2.68	A _{peak}	V _{BL} =24V, (I _L =typ.) (3)
Dimming Frequency	F _B	150	160	170	Hz	
Minimum Duty Ratio	D _{MIN}	5	10	-	%	(4)

Note (1) The power supply capacity should be higher than the total converter power consumption P_{BL}. Since the pulse width modulation (PWM) mode was applied for backlight dimming, the driving current changed as PWM duty on and off. The transient response of power supply should be considered for the changing loading when converter dimming.

Note (2) The measurement condition of Max. value is based on 31.5" backlight unit under input voltage 24V, average LED current 127.2 mA and lighting 1 hour later.

Note (3) The duration of rush current is about 30ms.

Note (4) 5% minimum duty ratio is only valid for electrical operation.

3.2.3 CONVERTER INTERFACE CHARACTERISTICS

Parameter	Symbol	Test Condition	Value			Unit	Note		
			Min.	Typ.	Max.				
On/Off Control Voltage	ON	VBLON	—	2.0	—	5.25	V	(6)	
	OFF		—	0	—	0.8	V		
External PWM Control Voltage	HI	VEPWM	—	2.0	—	5.25	V	Duty on	(5)
	LO		—	0	—	0.8	V	Duty off	
Error Signal	ERR	—	—	—	—	—	Abnormal: Open collector Normal: GND (4)		
VBL Rising Time	Tr1	—	30	—	—	ms	10%-90%V _{BL}		
Control Signal Rising Time	Tr	—	—	—	100	ms			
Control Signal Falling Time	Tf	—	—	—	100	ms			
PWM Signal Rising Time	TPWMR	—	—	—	50	us			
PWM Signal Falling Time	TPWMF	—	—	—	50	us			
Input Impedance	Rin	—	1	—	—	MΩ			
PWM Delay Time	TPWM	—	100	—	—	ms			
BLON Delay Time	T _{on}	—	300	—	—	ms			
	T _{on1}	—	300	—	—	ms			
BLON Off Time	Toff	—	300	—	—	ms			

Note (1) The Dimming signal should be valid before backlight turns on by BLON signal. It is inhibited to change the external PWM signal during backlight turn on period.

Note (2) The power sequence and control signal timing are shown in the Fig.1. For a certain reason, the converter has a possibility to be damaged with wrong power sequence and control signal timing.

Note (3) While system is turned ON or OFF, the power sequences must follow as below descriptions:

Turn ON sequence: VBL → PWM signal → BLON

Turn OFF sequence: BLOFF → PWM signal → VBL

Note (4) When converter protective function is triggered, ERR will output open collector status.

Note (5) The EPWM interface that inserts a pull up resistor to 5V in Max Duty (100%), please refers to Fig.2.

Note (6) The BLON interface that inserts a pull up resistor to 5V, please refers to Fig.2.

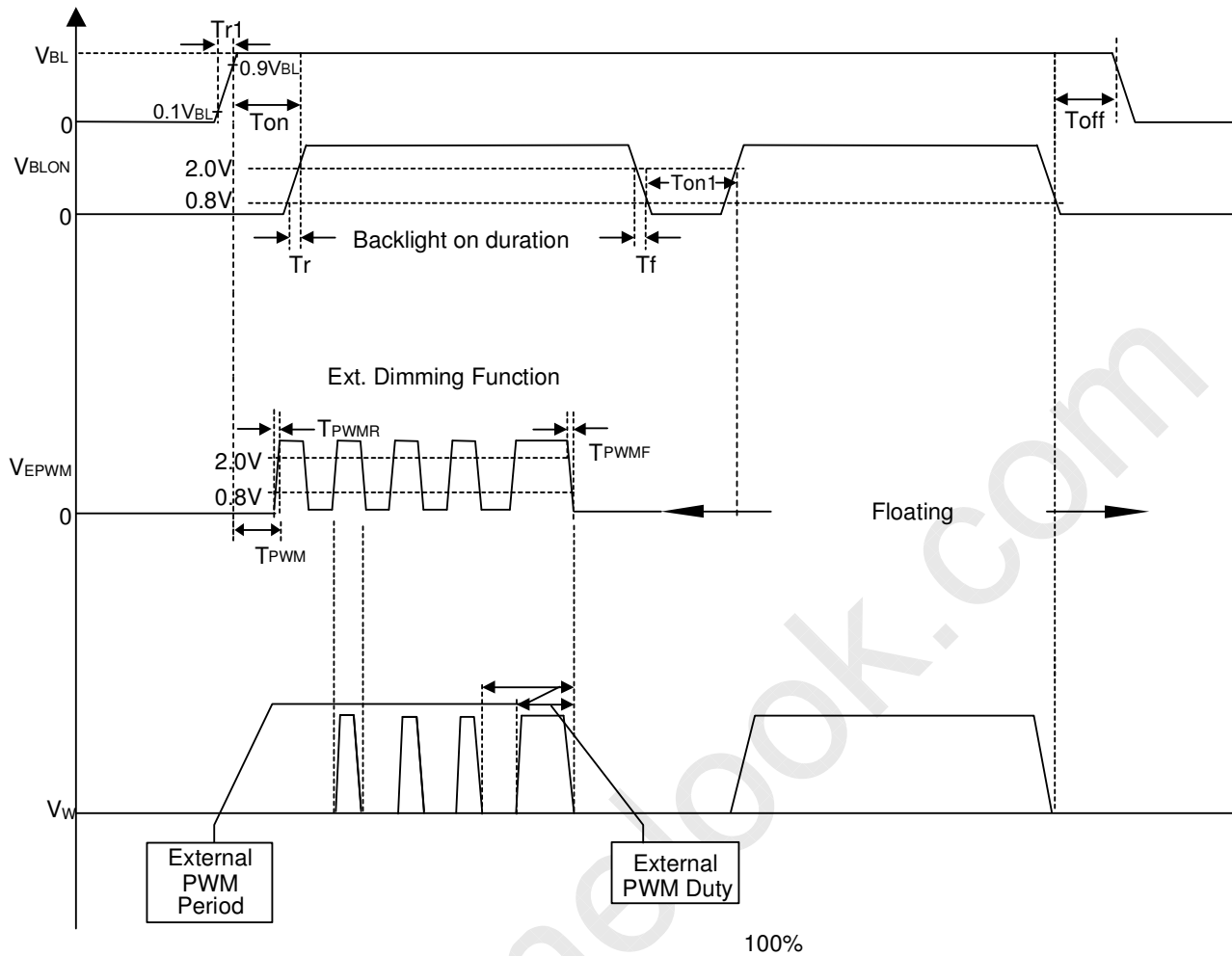

Fig. 1

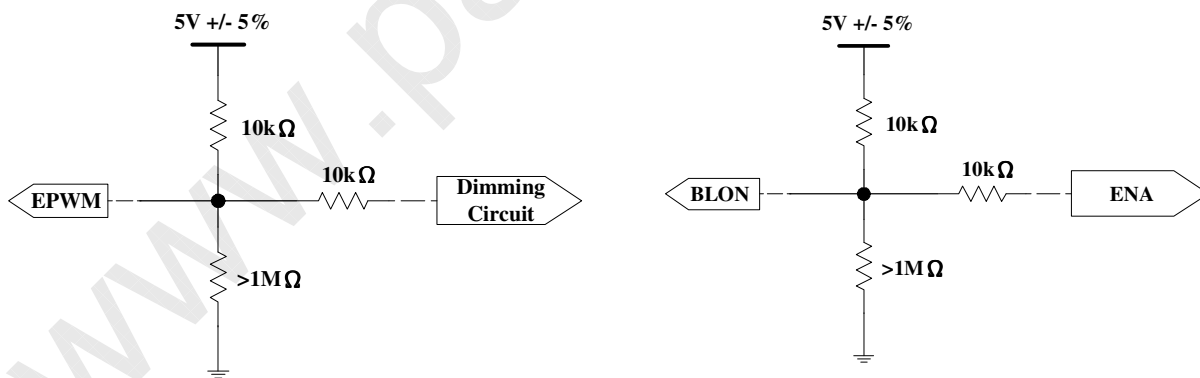
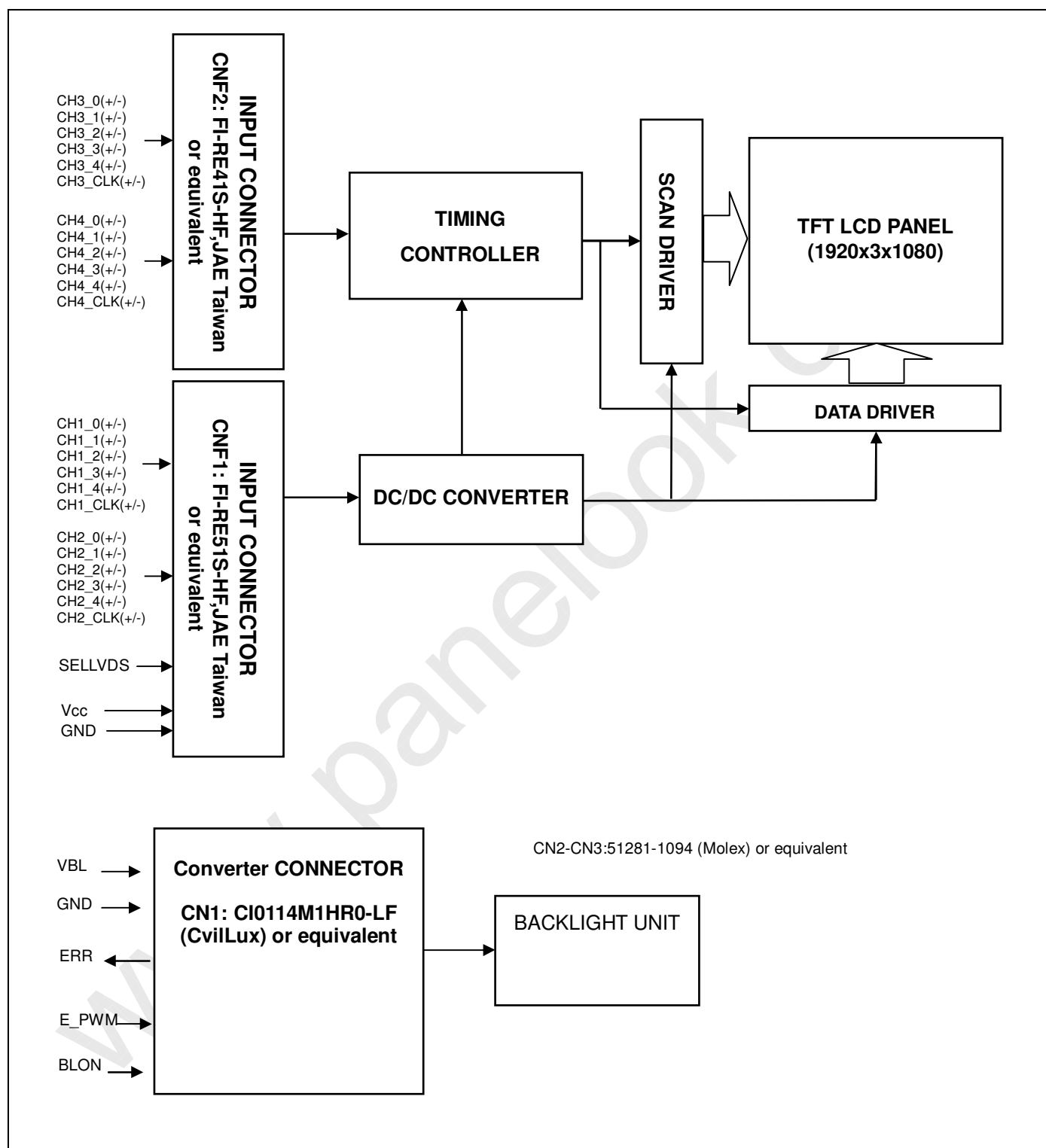

Fig. 2

4. BLOCK DIAGRAM OF INTERFACE

4.1 TFT LCD MODULE



5. INPUT TERMINAL PIN ASSIGNMENT

5.1 TFT LCD Module Input

CNF1 Connector Pin Assignment (FI-RE51S-HF(JAE) or equivalent)

Pin	Name	Description	Note
1	GND	Ground	
2	N.C.	No Connection	(1)
3	N.C.	No Connection	(1)
4	N.C.	No Connection	(1)
5	N.C.	No Connection	(1)
6	N.C.	No Connection	(1)
7	SELLVDS	LVDS Data Format Selection	(2)
8	N.C.	No Connection	(1)
9	N.C.	No Connection	(1)
10	N.C.	No Connection	(1)
11	GND	Ground	
12	CH1[0]-	First pixel Negative LVDS differential data input. Pair 0	
13	CH1[0]+	First pixel Positive LVDS differential data input. Pair 0	
14	CH1[1]-	First pixel Negative LVDS differential data input. Pair 1	
15	CH1[1]+	First pixel Positive LVDS differential data input. Pair 1	
16	CH1[2]-	First pixel Negative LVDS differential data input. Pair 1 2	
17	CH1[2]+	First pixel Positive LVDS differential data input. Pair 2	
18	GND	Ground	
19	CH1CLK-	First pixel Negative LVDS differential clock input.	
20	CH1CLK+	First pixel Positive LVDS differential clock input.	
21	GND	Ground	
22	CH1[3]-	First pixel Negative LVDS differential data input. Pair 3	
23	CH1[3]+	First pixel Positive LVDS differential data input. Pair 3	
24	CH1[4]-	First pixel Negative LVDS differential data input. Pair 4	
25	CH1[4]+	First pixel Positive LVDS differential data input. Pair 4	
26	N.C.	No Connection	(1)
27	N.C.	No Connection	(1)
28	CH2[0]-	Second pixel Negative LVDS differential data input. Pair 0	

29	CH2[0]+	Second pixel Positive LVDS differential data input. Pair 0	
30	CH2[1]-	Second pixel Negative LVDS differential data input. Pair 1	
31	CH2[1]+	Second pixel Positive LVDS differential data input. Pair 1	
32	CH2[2]-	Second pixel Negative LVDS differential data input. Pair 2	
33	CH2[2]+	Second pixel Positive LVDS differential data input. Pair 2	
34	GND	Ground	
35	CH2CLK-	Second pixel Negative LVDS differential clock input.	
36	CH2CLK+	Second pixel Positive LVDS differential clock input.	
37	GND	Ground	
38	CH2[3]-	Second pixel Negative LVDS differential data input. Pair 3	
39	CH2[3]+	Second pixel Positive LVDS differential data input. Pair 3	
40	CH2[4]-	Second pixel Negative LVDS differential data input. Pair 4	
41	CH2[4]+	Second pixel Positive LVDS differential data input. Pair 4	
42	N.C.	No Connection	(1)
43	N.C.	No Connection	(1)
44	GND	Ground	
45	GND	Ground	
46	GND	Ground	
47	N.C.	No Connection	(1)
48	VCC	+12V power supply	
49	VCC	+12V power supply	
50	VCC	+12V power supply	
51	VCC	+12V power supply	

CNF2 Connector Pin Assignment (FI-RE41S-HF(JAE) or equivalent)

Pin	Name	Description	Note
1	GND	Ground	
2	N.C.	No Connection	(1)
3	N.C.	No Connection	(1)
4	N.C.	No Connection	(1)
5	N.C.	No Connection	(1)
6	N.C.	No Connection	(1)
7	N.C.	No Connection	(1)

8	N.C.	No Connection	(1)
9	GND	Ground	
10	CH3[0]-	Third pixel Negative LVDS differential data input. Pair 0	
11	CH3[0]+	Third pixel Positive LVDS differential data input. Pair 0	
12	CH3[1]-	Third pixel Negative LVDS differential data input. Pair 1	
13	CH3[1]+	Third pixel Positive LVDS differential data input. Pair 1	
14	CH3[2]-	Third pixel Negative LVDS differential data input. Pair 2	
15	CH3[2]+	Third pixel Positive LVDS differential data input. Pair 2	
16	GND	Ground	
17	CH3CLK-	Third pixel Negative LVDS differential clock input.	
18	CH3CLK+	Third pixel Positive LVDS differential clock input.	
19	GND	Ground	
20	CH3[3]-	Third pixel Negative LVDS differential data input. Pair 3	
21	CH3[3]+	Third pixel Positive LVDS differential data input. Pair 3	
22	CH3[4]-	Third pixel Negative LVDS differential data input. Pair 4	
23	CH3[4]+	Third pixel Positive LVDS differential data input. Pair 4	
24	N.C.	No Connection	(1)
25	N.C.	No Connection	(1)
26	CH4[0]-	Fourth pixel Negative LVDS differential data input. Pair 0	
27	CH4[0]+	Fourth pixel Positive LVDS differential data input. Pair 0	
28	CH4[1]-	Fourth pixel Negative LVDS differential data input. Pair 1	
29	CH4[1]+	Fourth pixel Positive LVDS differential data input. Pair 1	
30	CH4[2]-	Fourth pixel Negative LVDS differential data input. Pair 2	
31	CH4[2]+	Fourth pixel Positive LVDS differential data input. Pair 2	
32	GND	Ground	
33	CH4CLK-	Fourth pixel Negative LVDS differential clock input.	
34	CH4CLK+	Fourth pixel Positive LVDS differential clock input.	
35	GND	Ground	
36	CH4[3]-	Fourth pixel Negative LVDS differential data input. Pair 3	
37	CH4[3]+	Fourth pixel Positive LVDS differential data input. Pair 3	
38	CH4[4]-	Fourth pixel Negative LVDS differential data input. Pair 4	
39	CH4[4]+	Fourth pixel Positive LVDS differential data input. Pair 4	

40	N.C.	No Connection	(1)
41	N.C.	No Connection	(1)

Note (1) Reserved for internal use. Please leave it open.

Note (2) High=connect to +3.3V: JEIDA Format ; Low= connect to GND or Open: VESA Format.

Note (3) Interface optional pin has internal scheme as following diagram. Customer should keep the interface voltage level requirement as below.

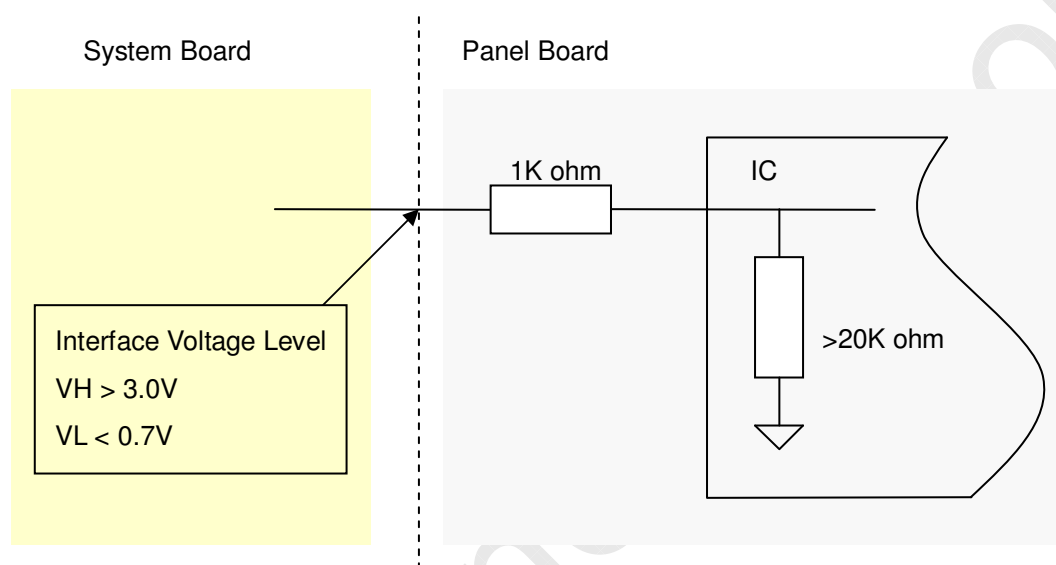

Note (4) LVDS 4-port Data Mapping

Port	Channel of LVDS	Data Stream
1st Port	First Pixel	1, 5, 9,1913, 1917
2nd Port	Second Pixel	2, 6, 10,1914, 1918
3rd Port	Third Pixel	3, 7, 11,1915, 1919
4th Port	Fourth Pixel	4, 8, 12,1916, 1920

5.2 BACKLIGHT UNIT

The pin configuration for the housing and the leader wire is shown in the table below.

CN: 51281-1094 (Molex)

Pin №	Symbol	Feature
1	VLED+	Positive of LED String
2		
3	NC	NC
4		
5		
6		
7	N1	Negative of LED String
8	N2	
9	N3	
10	N4	

5.3 CONVERTER UNIT

CN1(Header): CI0114M1HR0-LF (CvilLux)

Pin №	Symbol	Feature
1	VBL	+24V
2		
3		
4		
5		
6	GND	GND
7		
8		
9		
10		
11	ERR	Normal (GND) Abnormal (Open collector)
12	BLON	BL ON/OFF
13	NC	NC
14	E_PWM	External PWM Control

Notice

1. If Pin14 is open, E_PWM is 100% duty.
2. If Pin12 is open, BLU is turned on.

CN2~3: 51281-1094 (Molex)

Pin No	Symbol	Feature
1	VLED+	Positive of LED String
2		
3	NC	NC
4		
5		
6		
7	N2	Negative of LED String
8	N3	
9	N4	
10	N5	

5.4 BLOCK DIAGRAM OF INTERFACE

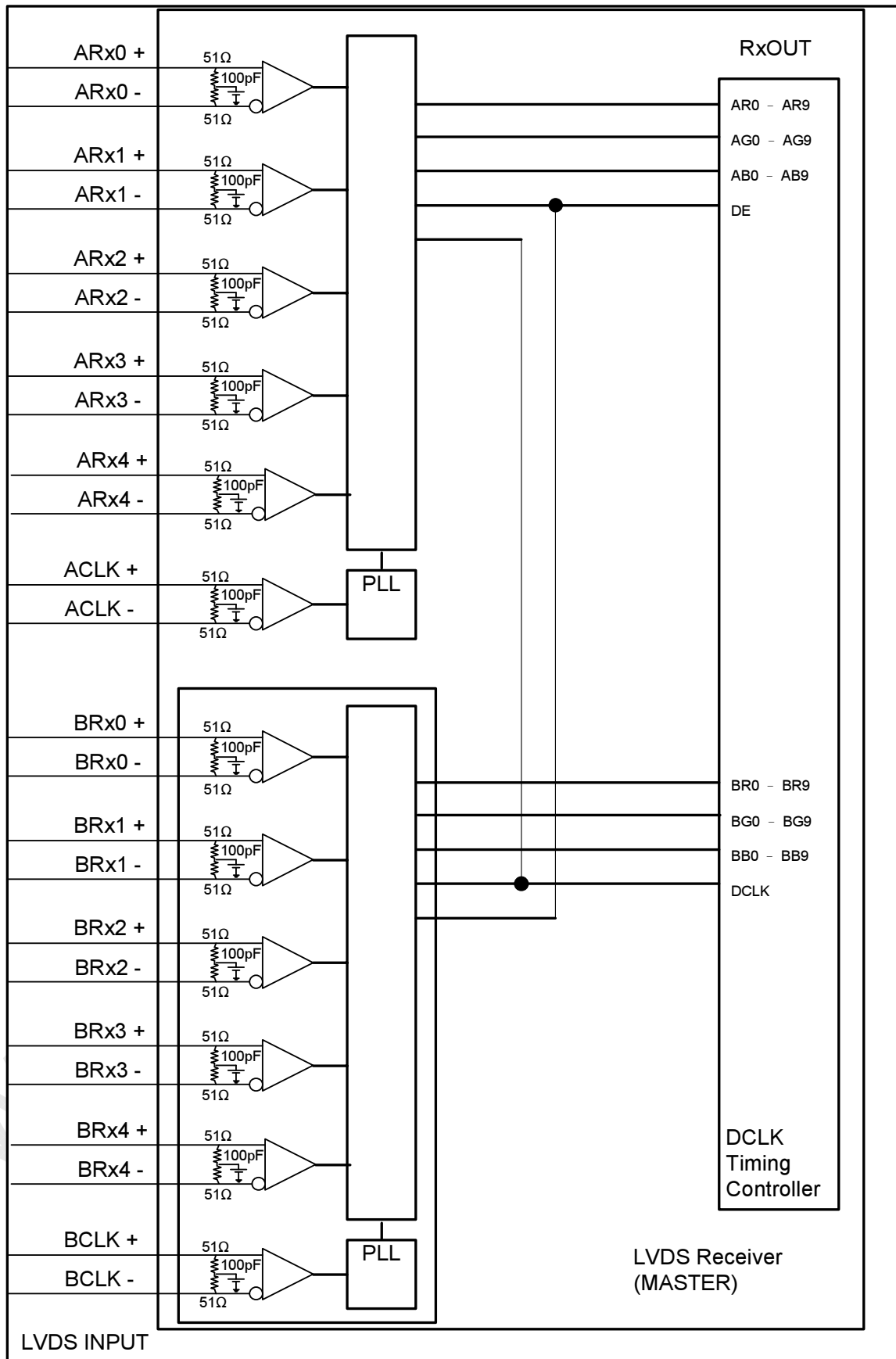

AR0~AR9: First pixel R data

AG0~AG9: First pixel G data

AB0~AB9: First pixel B data

BR0~BR9: Second pixel R data

BG0~BG9: Second pixel G data

BB0~BB9: Second pixel B data

DE: Data enable signal

DCLK: Data clock signal

The third and fourth pixel are followed the same rules.

CR0~CR9: Third pixel R data

CG0~CG9: Third pixel G data

CB0~CB9: Third pixel B data

DR0~DR9: Fourth pixel R data

DG0~DG9: Fourth pixel G data

DB0~DB9: Fourth pixel B data

Note (1) A ~ D channel are first, second, third and fourth pixel respectively.

Note (2) The system must have the transmitter to drive the module.

Note (3) LVDS cable impedance shall be 50 ohms per signal line or about 100 ohms per twist-pair line when it is used differentially.

5.5 LVDS INTERFACE

VESA Format : SELLVDS = L or Open

JEIDA Format : SELLVDS = H

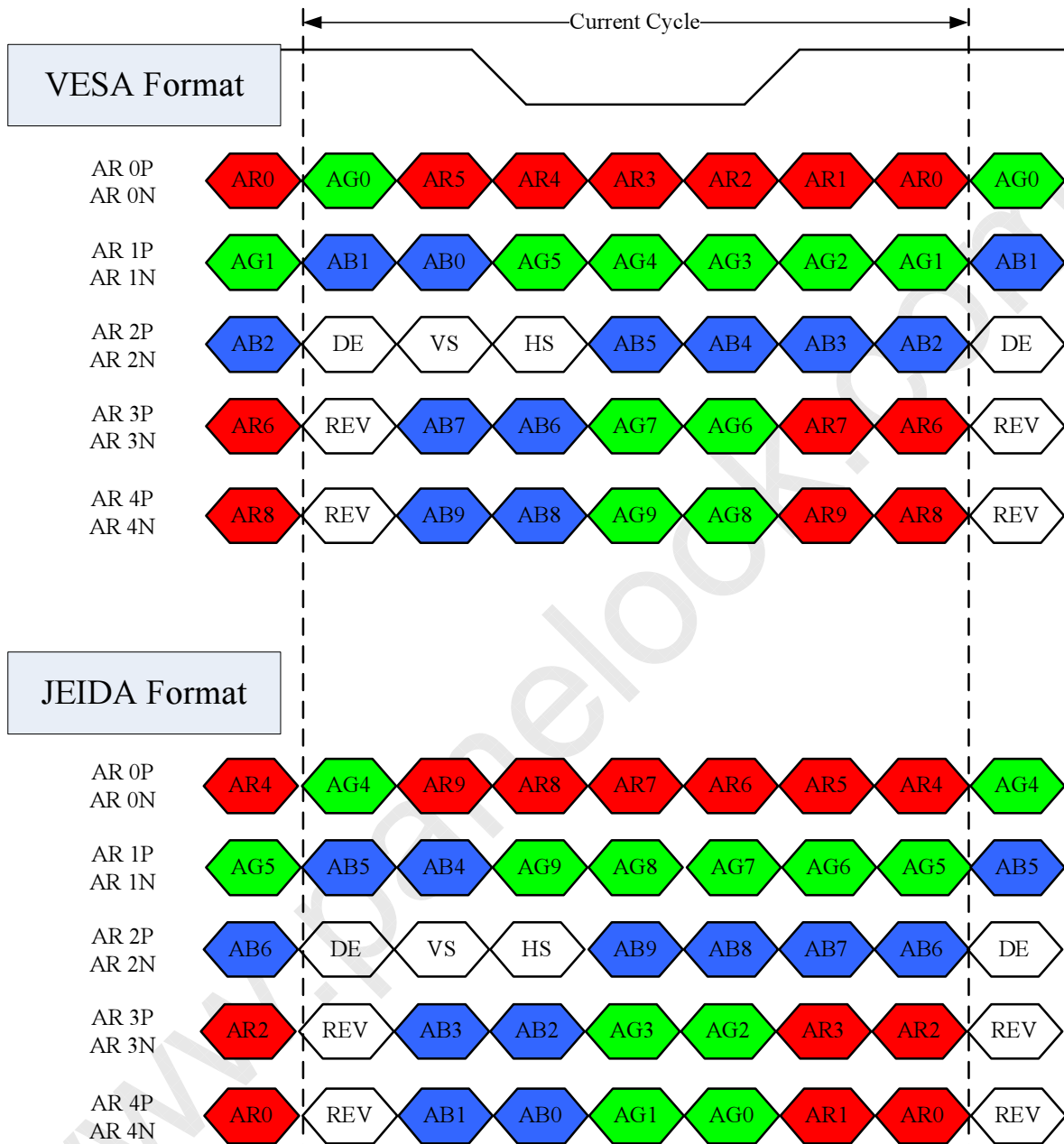

AR0~AR9 : First Pixel R Data (9; MSB, 0; LSB)

AG0~AG9 : First Pixel G Data (9; MSB, 0; LSB)

AB0~AB9 : First Pixel B Data (9; MSB, 0; LSB)

DE : Data enable signal

DCLK : Data clock signal

RSVD : Reserved

5.6 COLOR DATA INPUT ASSIGNMENT

The brightness of each primary color (red, green and blue) is based on the 10-bit gray scale data input for the color. The higher the binary input, the brighter the color. The table below provides the assignment of the color versus data input.

Color		Data Signal																																					
		Red										Green										Blue																	
		R9	R8	R7	R6	R5	R4	R3	R2	R1	R0	G9	G8	G7	G6	G5	G4	G3	G2	G1	G0	B9	B8	B7	B6	B5	B4	B3	B2	B1	B0								
Basic Colors	Black	0	0	0	0	0	0	0	0	0	0	0	0	0	0	0	0	0	0	0	0	0	0	0	0	0	0	0	0	0	0	0	0	0	0	0	0	0	
	Red	1	1	1	1	1	1	1	1	1	1	0	0	0	0	0	0	0	0	0	0	0	0	0	0	0	0	0	0	0	0	0	0	0	0	0	0	0	
	Green	0	0	0	0	0	0	0	0	0	0	1	1	1	1	1	1	1	1	1	1	0	0	0	0	0	0	0	0	0	0	0	0	0	0	0	0	0	0
	Blue	0	0	0	0	0	0	0	0	0	0	0	0	0	0	0	0	0	0	0	0	1	1	1	1	1	1	1	1	1	1	1	1	1	1	1	1	1	
	Cyan	0	0	0	0	0	0	0	0	0	0	1	1	1	1	1	1	1	1	1	1	1	1	1	1	1	1	1	1	1	1	1	1	1	1	1	1	1	
	Magenta	1	1	1	1	1	1	1	1	1	1	0	0	0	0	0	0	0	0	0	0	1	1	1	1	1	1	1	1	1	1	1	1	1	1	1	1	1	
	Yellow	1	1	1	1	1	1	1	1	1	1	1	1	1	1	1	1	1	1	1	1	0	0	0	0	0	0	0	0	0	0	0	0	0	0	0	0	0	
	White	1	1	1	1	1	1	1	1	1	1	1	1	1	1	1	1	1	1	1	1	1	1	1	1	1	1	1	1	1	1	1	1	1	1	1	1	1	
Gray Scale Of Red	Red (0) / Dark	0	0	0	0	0	0	0	0	0	0	0	0	0	0	0	0	0	0	0	0	0	0	0	0	0	0	0	0	0	0	0	0	0	0	0	0		
	Red (1)	0	0	0	0	0	0	0	0	0	1	0	0	0	0	0	0	0	0	0	0	0	0	0	0	0	0	0	0	0	0	0	0	0	0	0	0	0	
	Red (2)	0	0	0	0	0	0	0	0	1	0	0	0	0	0	0	0	0	0	0	0	0	0	0	0	0	0	0	0	0	0	0	0	0	0	0	0	0	
	⋮	⋮	⋮	⋮	⋮	⋮	⋮	⋮	⋮	⋮	⋮	⋮	⋮	⋮	⋮	⋮	⋮	⋮	⋮	⋮	⋮	⋮	⋮	⋮	⋮	⋮	⋮	⋮	⋮	⋮	⋮	⋮	⋮	⋮	⋮	⋮	⋮		
	Red (1021)	1	1	1	1	1	1	1	1	0	1	0	0	0	0	0	0	0	0	0	0	0	0	0	0	0	0	0	0	0	0	0	0	0	0	0	0	0	
	Red (1022)	1	1	1	1	1	1	1	1	1	0	0	0	0	0	0	0	0	0	0	0	0	0	0	0	0	0	0	0	0	0	0	0	0	0	0	0	0	
	Red (1023)	1	1	1	1	1	1	1	1	1	1	0	0	0	0	0	0	0	0	0	0	0	0	0	0	0	0	0	0	0	0	0	0	0	0	0	0	0	
	Gray Scale Of Green	Green (0) / Dark	0	0	0	0	0	0	0	0	0	0	0	0	0	0	0	0	0	0	0	0	0	0	0	0	0	0	0	0	0	0	0	0	0	0	0	0	0
Green (1)		0	0	0	0	0	0	0	0	0	0	0	0	0	0	0	0	0	0	0	0	0	0	0	0	0	0	0	0	0	0	0	0	0	0	0	0	0	
Green (2)		0	0	0	0	0	0	0	0	0	0	0	0	0	0	0	0	0	0	0	0	0	0	0	0	0	0	0	0	0	0	0	0	0	0	0	0	0	
⋮		⋮	⋮	⋮	⋮	⋮	⋮	⋮	⋮	⋮	⋮	⋮	⋮	⋮	⋮	⋮	⋮	⋮	⋮	⋮	⋮	⋮	⋮	⋮	⋮	⋮	⋮	⋮	⋮	⋮	⋮	⋮	⋮	⋮	⋮	⋮	⋮		
Green (1021)		0	0	0	0	0	0	0	0	0	0	1	1	1	1	1	1	1	1	1	0	1	0	0	0	0	0	0	0	0	0	0	0	0	0	0	0	0	
Green (1022)		0	0	0	0	0	0	0	0	0	0	1	1	1	1	1	1	1	1	1	0	0	0	0	0	0	0	0	0	0	0	0	0	0	0	0	0	0	
Green (1023)		0	0	0	0	0	0	0	0	0	0	1	1	1	1	1	1	1	1	1	1	0	0	0	0	0	0	0	0	0	0	0	0	0	0	0	0	0	
Gray Scale Of Blue		Blue (0) / Dark	0	0	0	0	0	0	0	0	0	0	0	0	0	0	0	0	0	0	0	0	0	0	0	0	0	0	0	0	0	0	0	0	0	0	0	0	0
	Blue (1)	0	0	0	0	0	0	0	0	0	0	0	0	0	0	0	0	0	0	0	0	0	0	0	0	0	0	0	0	0	0	0	0	0	0	0	0	1	
	Blue (2)	0	0	0	0	0	0	0	0	0	0	0	0	0	0	0	0	0	0	0	0	0	0	0	0	0	0	0	0	0	0	0	0	0	0	0	0	1	
	⋮	⋮	⋮	⋮	⋮	⋮	⋮	⋮	⋮	⋮	⋮	⋮	⋮	⋮	⋮	⋮	⋮	⋮	⋮	⋮	⋮	⋮	⋮	⋮	⋮	⋮	⋮	⋮	⋮	⋮	⋮	⋮	⋮	⋮	⋮	⋮	⋮		
	Blue (1021)	0	0	0	0	0	0	0	0	0	0	0	0	0	0	0	0	0	0	0	0	1	1	1	1	1	1	1	1	1	1	1	1	1	1	1	0	1	
	Blue (1022)	0	0	0	0	0	0	0	0	0	0	0	0	0	0	0	0	0	0	0	0	1	1	1	1	1	1	1	1	1	1	1	1	1	1	1	1	0	
	Blue (1023)	0	0	0	0	0	0	0	0	0	0	0	0	0	0	0	0	0	0	0	0	1	1	1	1	1	1	1	1	1	1	1	1	1	1	1	1	0	

Note (1) 0: Low Level Voltage, 1: High Level Voltage

6. INTERFACE TIMING

6.1 INPUT SIGNAL TIMING SPECIFICATIONS

(Ta = 25 ± 2 °C)

The input signal timing specifications are shown as the following table and timing diagram.

Signal	Item	Symbol	Min.	Typ.	Max.	Unit	Note
LVDS Receiver Clock	Frequency	$F_{clk_{in}}$ (=1/TC)	60	74.25	78	MHz	
	Input cycle to cycle jitter	T_{rcj}	—	—	200	ps	(2)
	Spread spectrum modulation range	$F_{clk_{in_mod}}$	$F_{clk_{in}}-2\%$	—	$F_{clk_{in}}+2\%$	MHz	(3)
	Spread spectrum modulation frequency	F_{SSM}	—	—	200	KHz	
LVDS Receiver Data	Setup Time	T_{lvsu}	600	—	—	ps	
	Hold Time	T_{lvhd}	600	—	—	ps	
Vertical Active Display Term	Frame Rate	F_{r5}	—	100	—	Hz	
		F_{r6}	—	120	—	Hz	
	Total	T_v	1090	1125	1395	Th	$T_v=T_{vd}+T_{vb}$
	Display	T_{vd}	1080	1080	1080	Th	
	Blank	T_{vb}	10	45	315	Th	
Horizontal Active Display Term	Total	T_h	520	550	670	Tc	$T_h=T_{hd}+T_{hb}$
	Display	T_{hd}	480	480	480	Tc	
	Blank	T_{hb}	40	70	190	Tc	

Note (1) Since the module is operated in DE only mode, Hsync and Vsync input signals should be set to low logic level. Otherwise, this module would operate abnormally.

Note (2) Please make sure the range of pixel clock has follow the below equation:

$$F_{clk_{in(max)}} \geq F_{r6} \times T_v \times T_h$$

$$F_{r5} \times T_v \times T_h \geq F_{clk_{in(min)}}$$

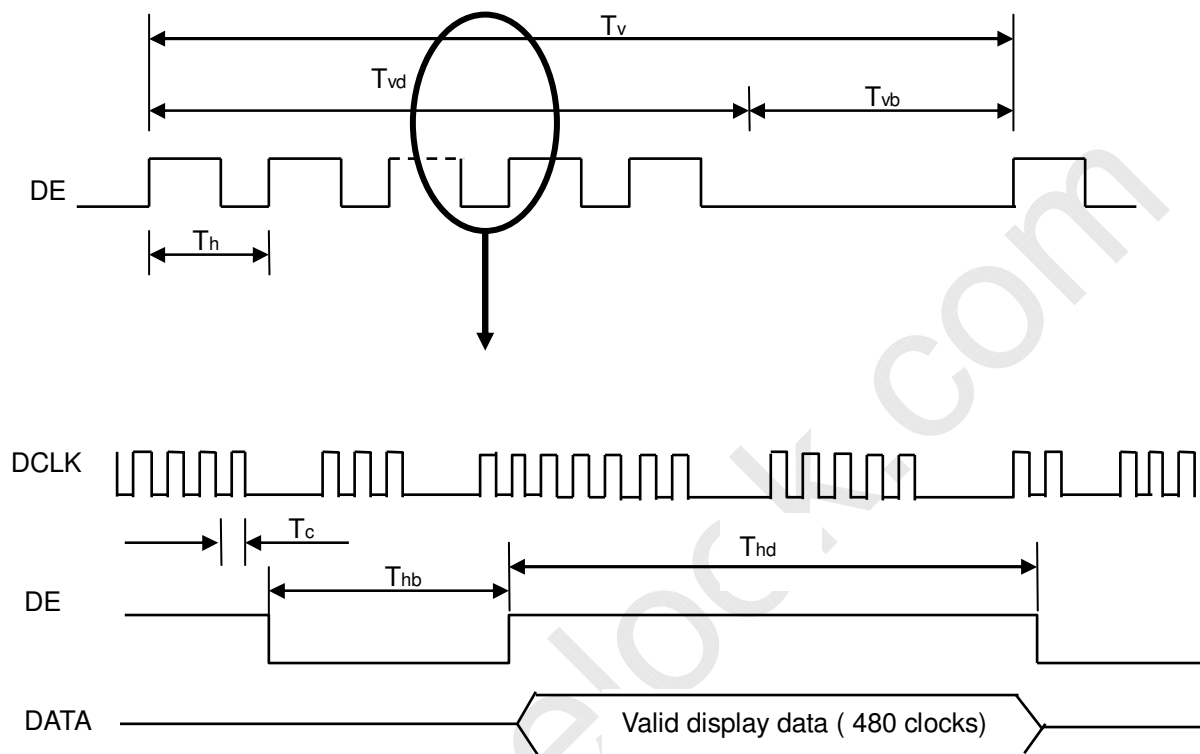
INPUT SIGNAL TIMING DIAGRAM

Note (3) The input clock cycle-to-cycle jitter is defined as below figures. $Trcl = |T_1 - T_1|$

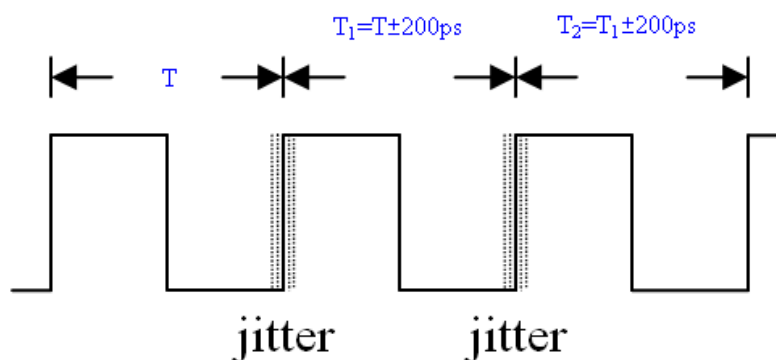

Note (4) The SSCG (Spread spectrum clock generator) is defined as below figures.

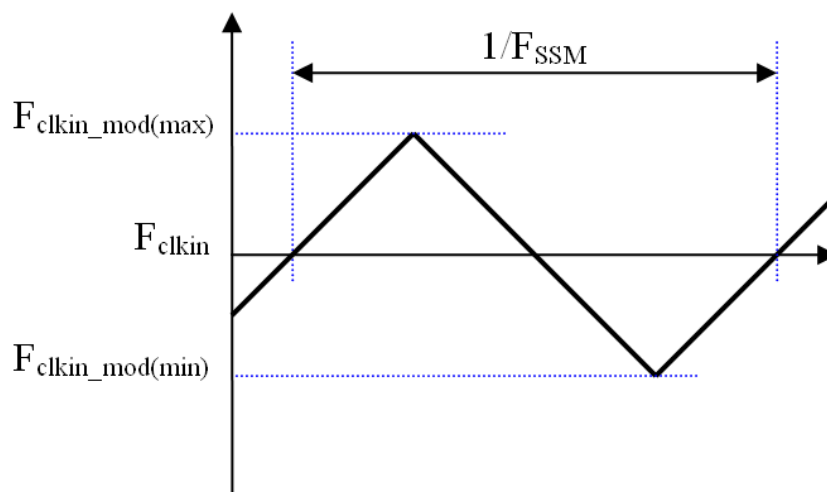

Note (5) The LVDS timing diagram and setup/hold time is defined and showing as the following figures

LVDS RECEIVER INTERFACE TIMING DIAGRAM

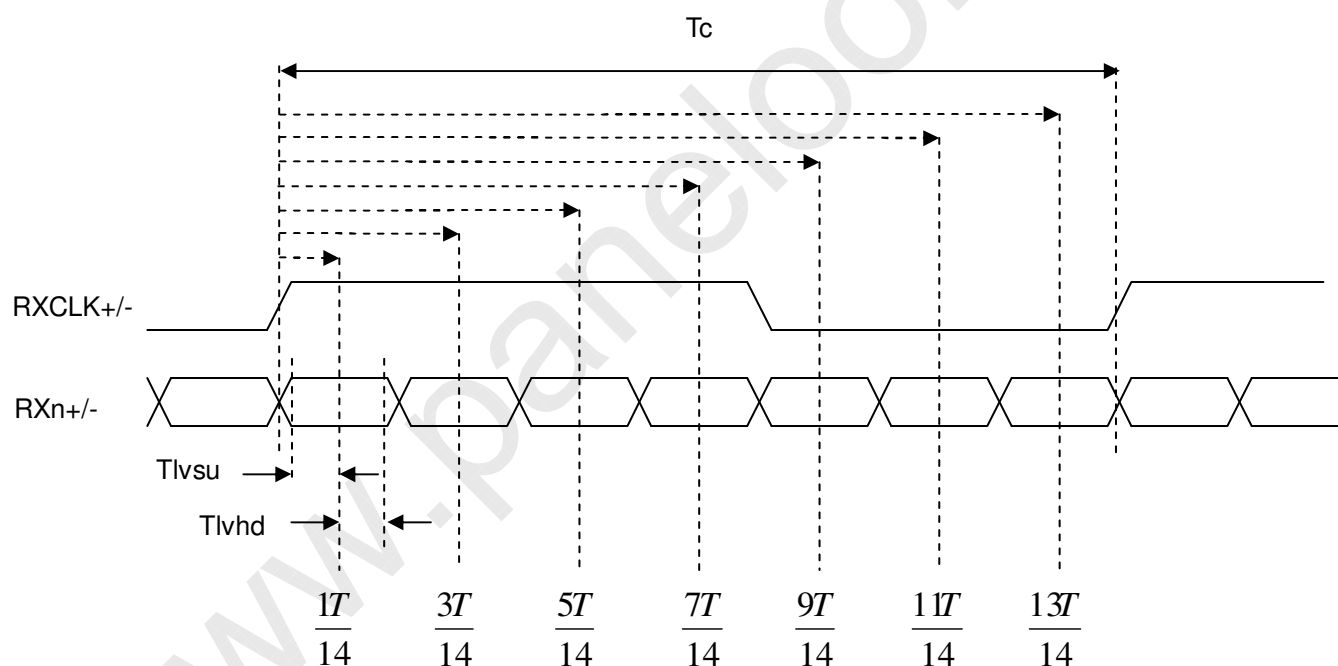

6.2 POWER ON/OFF SEQUENCE

($T_a = 25 \pm 2 \text{ }^\circ\text{C}$)

To prevent a latch-up or DC operation of LCD module, the power on/off sequence should be as the diagram below.

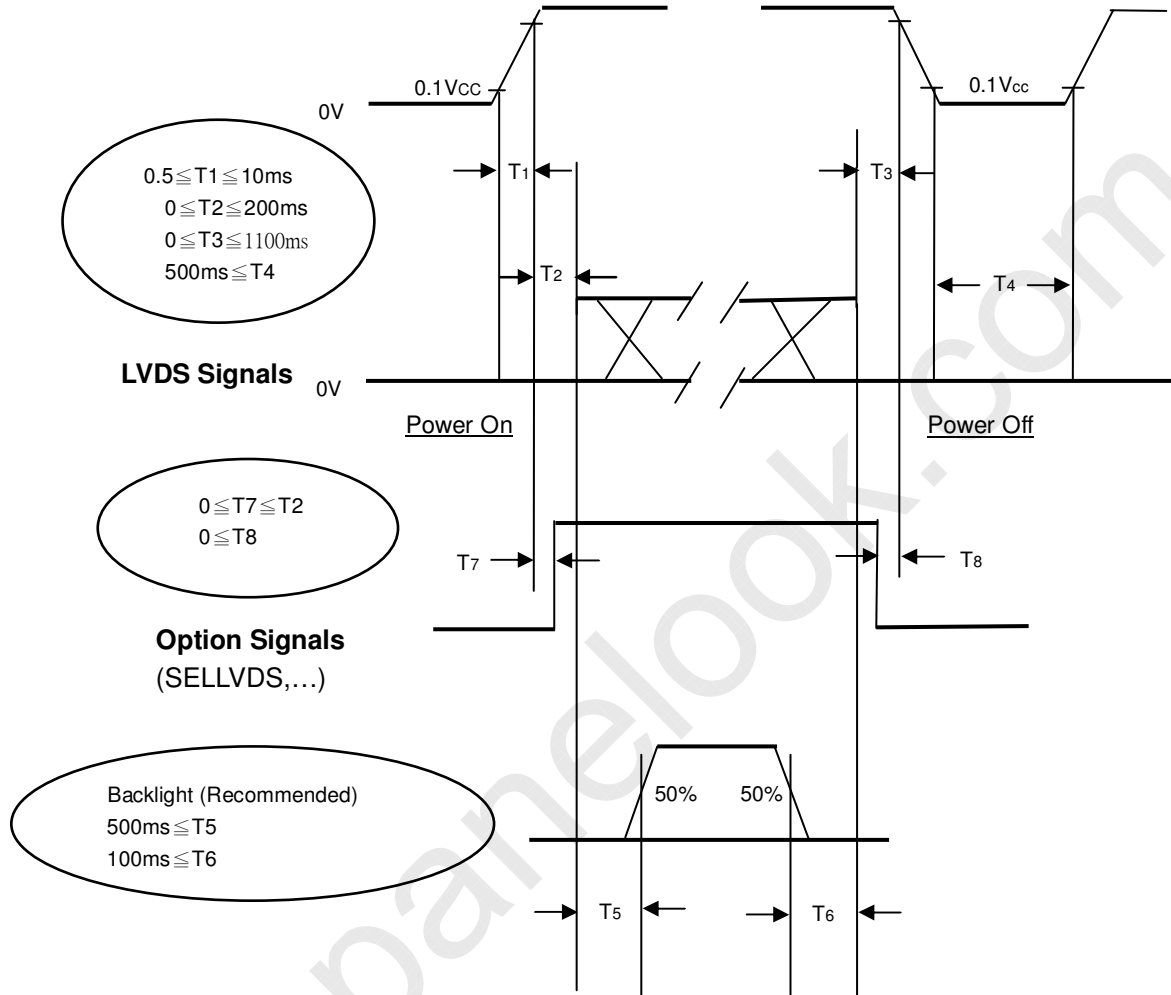

Power ON/OFF Sequence

Note (1) The supply voltage of the external system for the module input should follow the definition of V_{cc} .

Note (2) Apply the lamp voltage within the LCD operation range. When the backlight turns on before the LCD operation or the LCD turns off before the backlight turns off, the display may momentarily become abnormal screen.

Note(3) In case of V_{cc} is in off level, please keep the level of input signals on the low or high impedance. If $T2 < 0$, that maybe cause electrical overstress failure

Note (4) $T4$ should be measured after the module has been fully discharged between power off and on period.

Note (5) Interface signal shall not be kept at high impedance when the power is on.

7. OPTICAL CHARACTERISTICS
7.1 TEST CONDITIONS

Item	Symbol	Value	Unit
Ambient Temperature	Ta	25±2	oC
Ambient Humidity	Ha	50±10	%RH
Supply Voltage	V _{CC}	12	V
Input Signal	According to typical value in "3. ELECTRICAL CHARACTERISTICS"		
LED Current	I _L	120±7.2	mA

The LCD module should be stabilized at given temperature for 1 hour to avoid abrupt temperature change during measuring in a windless room.

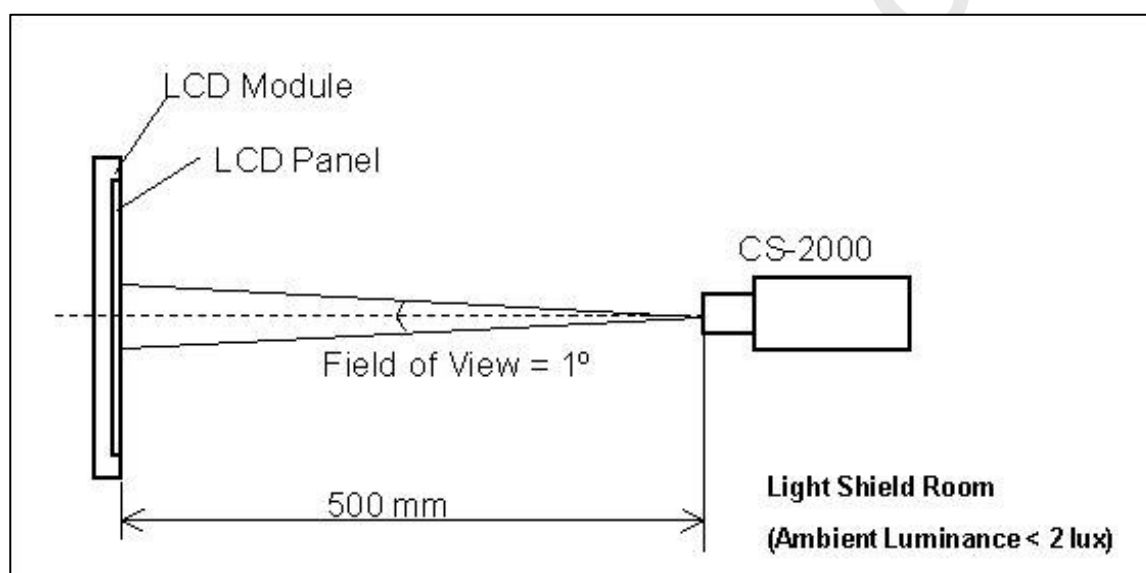

7.2 OPTICAL SPECIFICATIONS

The relative measurement methods of optical characteristics are shown in 7.2. The following items should be measured under the test conditions described in 7.1 and stable environment shown in 7.1.

Item		Symbol	Condition	Min.	Typ.	Max.	Unit	Note				
Contrast Ratio		CR		3500	5000	-	-	(2)				
Response Time (VA)		Gray to gray		-	6.5	-	ms	(3)				
Center Luminance of White		L_c		360	450	-	cd/m ²	(4)				
White Variation		δW		-	-	1.3	-	(6)				
Cross Talk		CT		-	-	4	%	(5)				
Color Chromaticity	Red	Rx	$\theta_x=0^\circ, \theta_y=0^\circ$ Viewing angle at normal direction	Typ. -0.03	0.635	Typ. +0.03	-	-				
		Ry			0.330		-					
	Green	Gx			0.299		-					
		Gy			0.623		-					
	Blue	Bx			0.152		-					
		By			0.054		-					
	White	Wx			0.280		-					
		Wy			0.290		-					
	Color Gamut				C.G		-		72	-	%	NTSC
	Viewing Angle	Horizontal			θ_{x+}		CR \geq 20 (VA)		-	88(VA)	-	Deg.
θ_{x-}			-	88(VA)	-							
Vertical		θ_{Y+}	-	88(VA)	-							
		θ_{Y-}	-	88(VA)	-							

Note (1) Definition of Viewing Angle (θ_x, θ_y) :

Viewing angles are measured by Conoscope Cono-80 (or Eldim EZ-Contrast 160R)

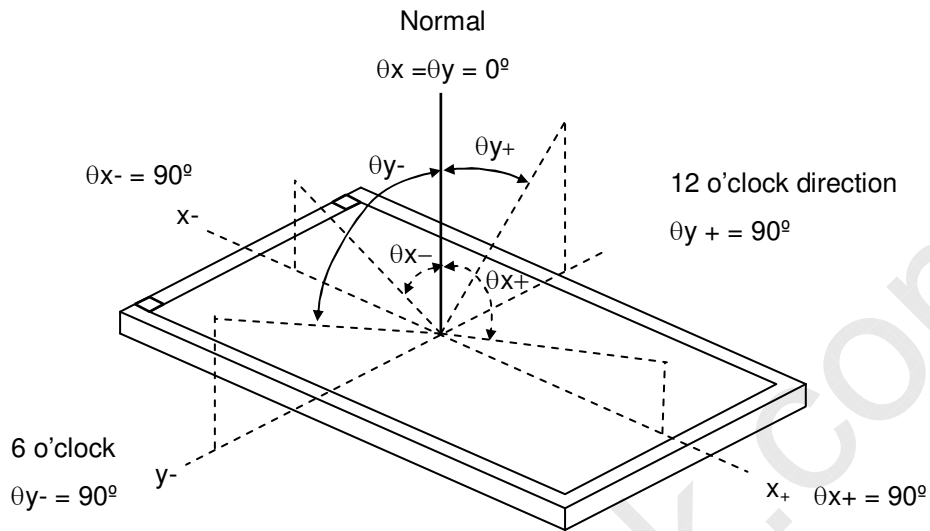

Note (2) Definition of Contrast Ratio (CR) :

The contrast ratio can be calculated by the following expression.

$$\text{Contrast Ratio (CR)} = \frac{\text{Surface Luminance of L255}}{\text{Surface Luminance of L0}}$$

L255: Luminance of gray level 255

L 0: Luminance of gray level 0

CR = CR (5), where CR (X) is corresponding to the Contrast Ratio of the point X at the figure in Note (6).

Note (3) Definition of Gray-to-Gray Switching Time:

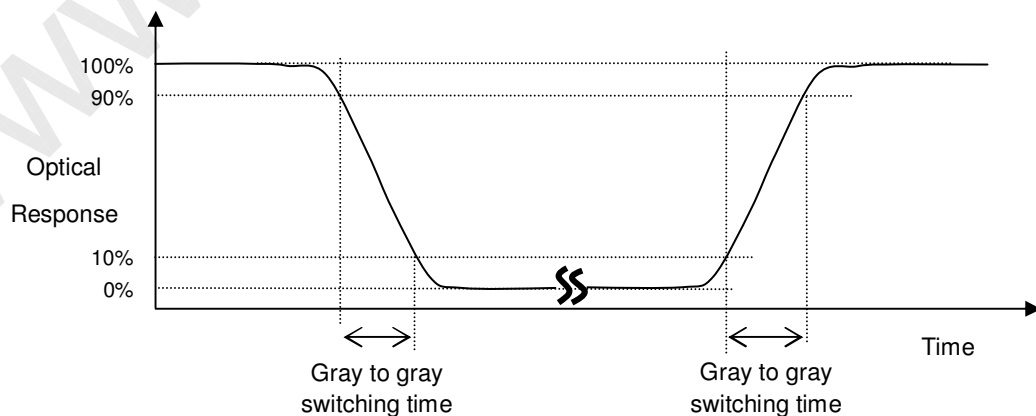

The driving signal means the signal of gray level 0, 124, 252, 380, 508, 636, 764, 892 and 1023.

Gray to gray average time means the average switching time of gray level 0, 124, 252, 380, 508, 636,

764, 892 and 1023 to each other.

Note (4) Definition of Luminance of White (L_C):

Measure the luminance of gray level 255 at center point and 5 points

$L_C = L(5)$, where $L(X)$ is corresponding to the luminance of the point X at the figure in Note (6).

Note (5) Definition of Cross Talk (CT):

$$CT = |Y_B - Y_A| / Y_A \times 100 (\%)$$

Where:

Y_A = Luminance of measured location without gray level 255 pattern (cd/m²)

Y_B = Luminance of measured location with gray level 255 pattern (cd/m²)

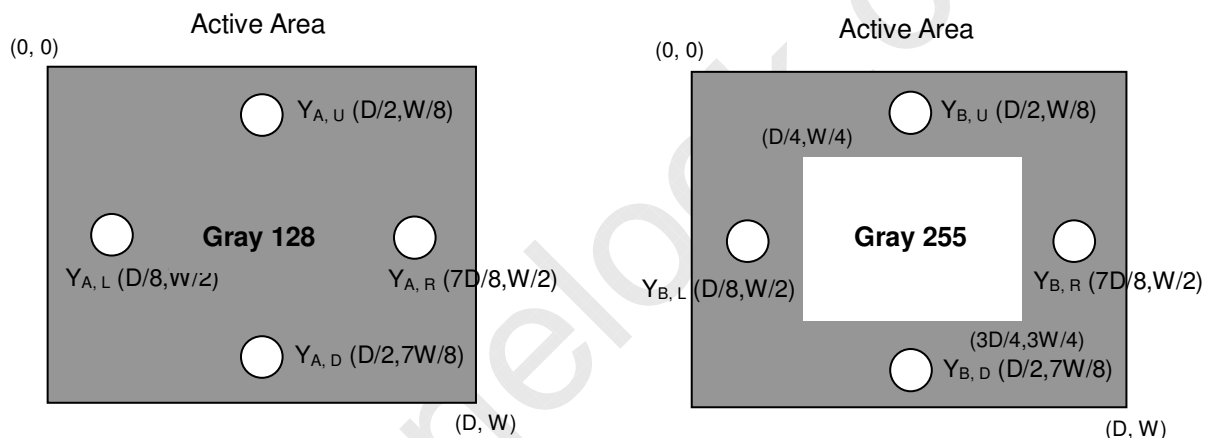

Note (6) Definition of White Variation (δW):

Measure the luminance of gray level 255 at 5 points

$$\delta W = \text{Maximum} [L(1), L(2), L(3), L(4), L(5)] / \text{Minimum} [L(1), L(2), L(3), L(4), L(5)]$$

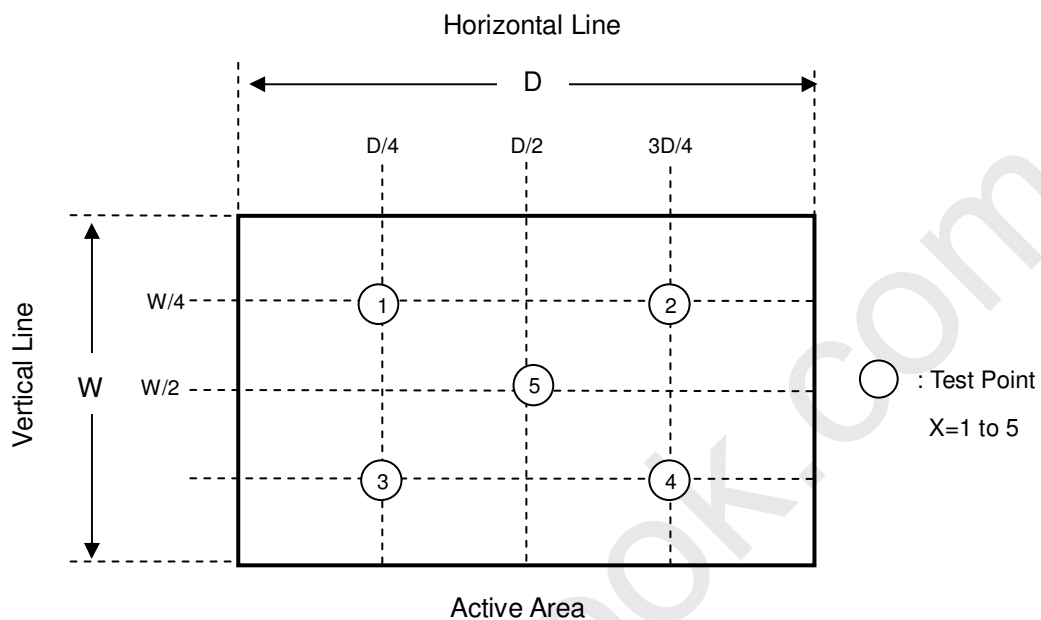

8 PRECAUTIONS

8.1 ASSEMBLY AND HANDLING PRECAUTIONS

- [1] Do not apply rough force such as bending or twisting to the module during assembly.
- [2] It is recommended to assemble or to install a module into the user's system in clean working areas. The dust and oil may cause electrical short or worsen the polarizer.
- [3] Do not apply pressure or impulse to the module to prevent the damage of LCD panel and Backlight.
- [4] Always follow the correct power-on sequence when the LCD module is turned on. This can prevent the damage and latch-up of the CMIS LSI chips.
- [5] Bezel of Set can not press or touch the panel surface. It will make light leakage or scrape.
- [6] Do not plug in or pull out the I/F connector while the module is in operation.
- [7] Do not disassemble the module.
- [8] Use a soft dry cloth without chemicals for cleaning, because the surface of polarizer is very soft and easily scratched.
- [9] Moisture can easily penetrate into LCD module and may cause the damage during operation.
- [10] When storing modules as spares for a long time, the following precaution is necessary.
 - [10.1] Do not leave the module in high temperature, and high humidity for a long time. It is highly recommended to store the module with temperature from 0 to 35°C at normal humidity without condensation.
 - [10.2] The module shall be stored in dark place. Do not store the TFT-LCD module in direct sunlight or fluorescent light.
- [11] When ambient temperature is lower than 10°C, the display quality might be reduced. For example, the response time will become slow, and the starting voltage of CCFL will be higher than that of room temperature.

8.2 SAFETY PRECAUTIONS

- [1] The startup voltage of a Backlight is approximately 1000 Volts. It may cause an electrical shock while assembling with the inverter. Do not disassemble the module or insert anything into the Backlight unit.
- [2] If the liquid crystal material leaks from the panel, it should be kept away from the eyes or mouth. In case of contact with hands, skin or clothes, it has to be washed away thoroughly with soap.
- [3] After the module's end of life, it is not harmful in case of normal operation and storage.

9. DEFINITION OF LABELS

9.1 CMI MODULE LABEL

The barcode nameplate is pasted on each module as illustration, and its definitions are as following explanation.

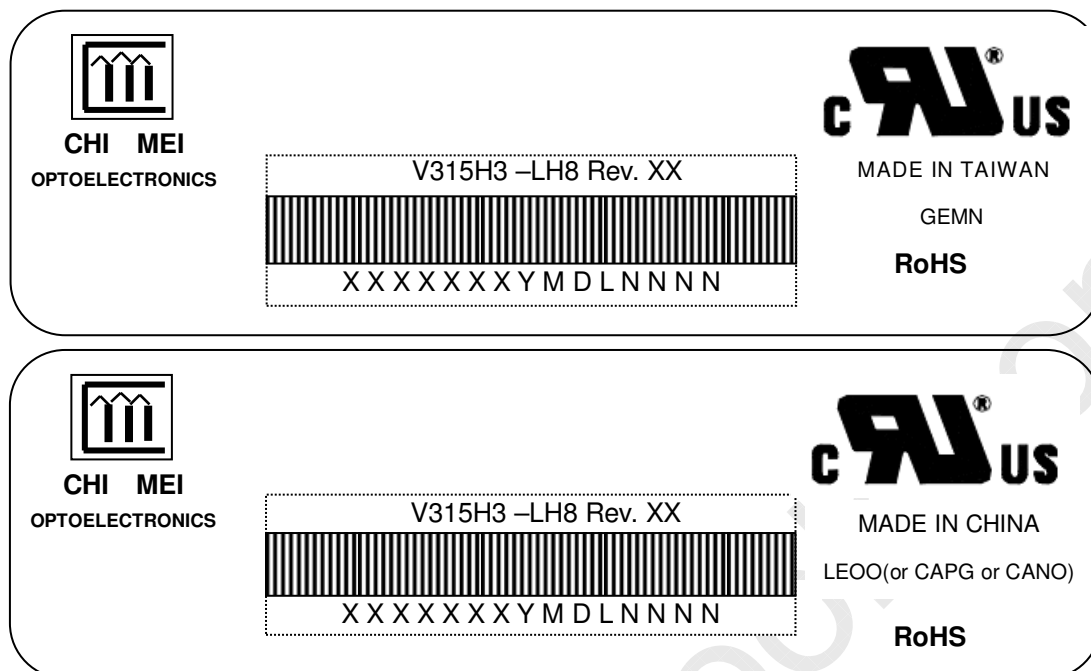

Model Name: V315H3-LH8

Revision: Rev. XX, for example: A0, A1... B1, B2... or C1, C2...etc.

Serial ID: X X X X X X Y M D L N N N N

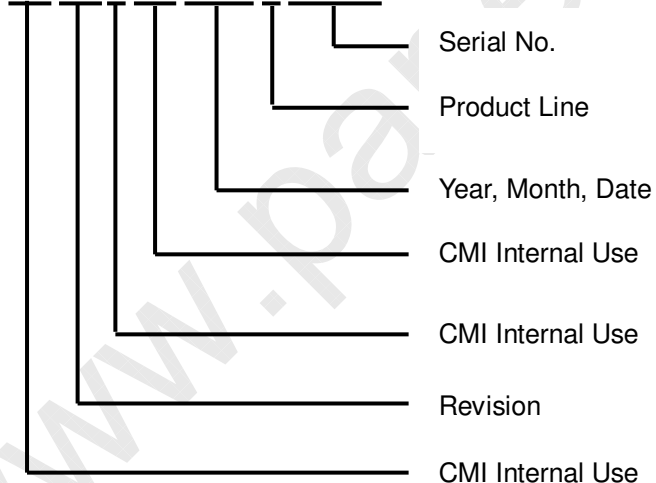

Serial ID includes the information as below:

Manufactured Date:

Year : 2001=1, 2002=2, 2003=3, 2004=4...2010=0, 2011=1, 2012=2...

Month: 1~9, A~C, for Jan. ~ Dec.

Day: 1~9, A~Y, for 1st to 31st, exclude I ,O, and U.

Revision Code : Cover all the change

Serial No. : Manufacturing sequence of product

Product Line : 1 → Line1, 2 → Line 2, ...etc.

10. PACKAGING

10.1 PACKAGING SPECIFICATIONS

- (1) 7 LCD TV modules / 1 Box
- (2) Box dimensions : 826(L)x376(W)x540(H)mm
- (3) Weight : Approx. 35 Kg (7 modules per box)

10.2 PACKAGING METHOD

Figures 10-1 and 10-2 are the packing method

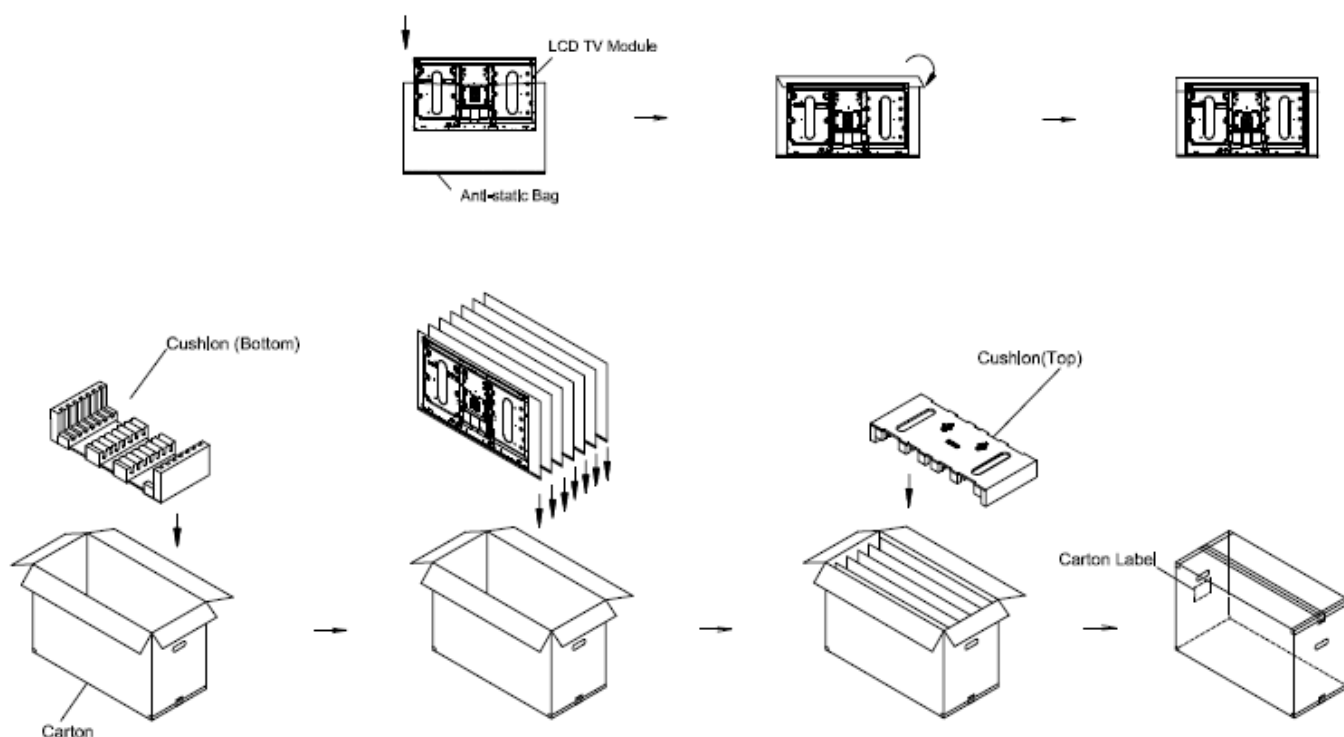
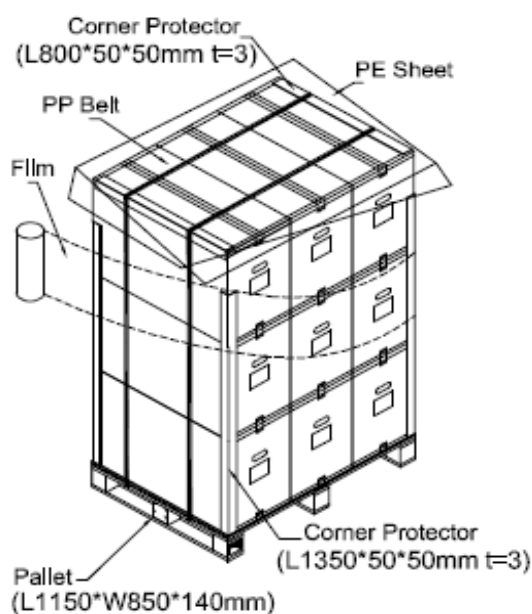
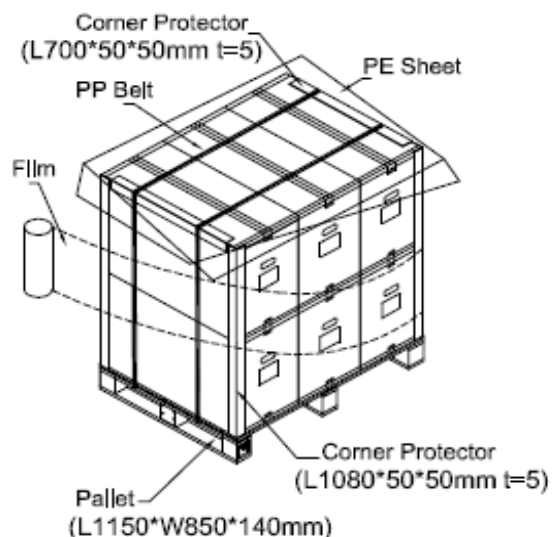

Figure 10-1 packing method

Sea / Land Transportation (40ft Container)



Air Transportation



Sea / Land Transportation (40ft HQ Container)

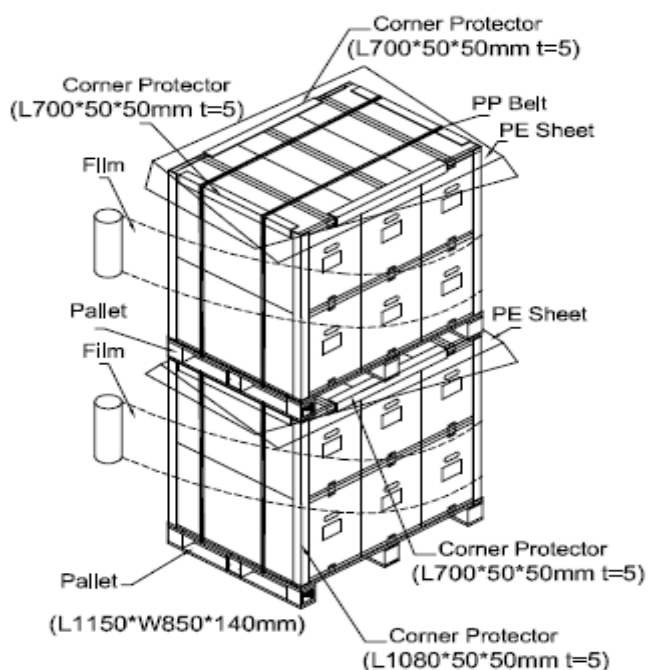

Figure 10-2 packing method

11. INTERNATIONAL STANDARD

11.1 SAFETY

- (1) UL 60950-1, UL 60065 ; Standard for Safety of information Technology Equipment including electrical Business Equipment.
- (2) IEC 60950-1:2001, IEC 60065:2001; Standard for Safety of International Electrotechnical Commission.
- (3) EN 60950:2001+A11, EN 60065:2002+A1:2006; European Committee for Electrotechnical Standardization (CENCLEC), EUROPEAN STANDARD for Safety of information Technology Equipment including Electrical Business Equipment.

11.2 EMC

- (1) ANSI C63.4 "Methods of Measurement of Radio-Noise Emissions from Low-Voltage Electrical and Electrical Equipment in the Range of 9kHz to 40GHz. " American National standards institute(ANSI), 1992
- (2) C.I.S.P.R "Limits and Methods of Measurement of Radio Interface Characteristics of Information Technology Equipment. " International Special Committee on Radio Interference.
- (3) EN55022 "Limits and Methods of Measurement of Radio Interface Characteristics of Information Technology Equipment. "European Committee for Electrotechnical Standardization(CENCLEC) , 1998

12. MECHANICAL CHARACTERISTIC

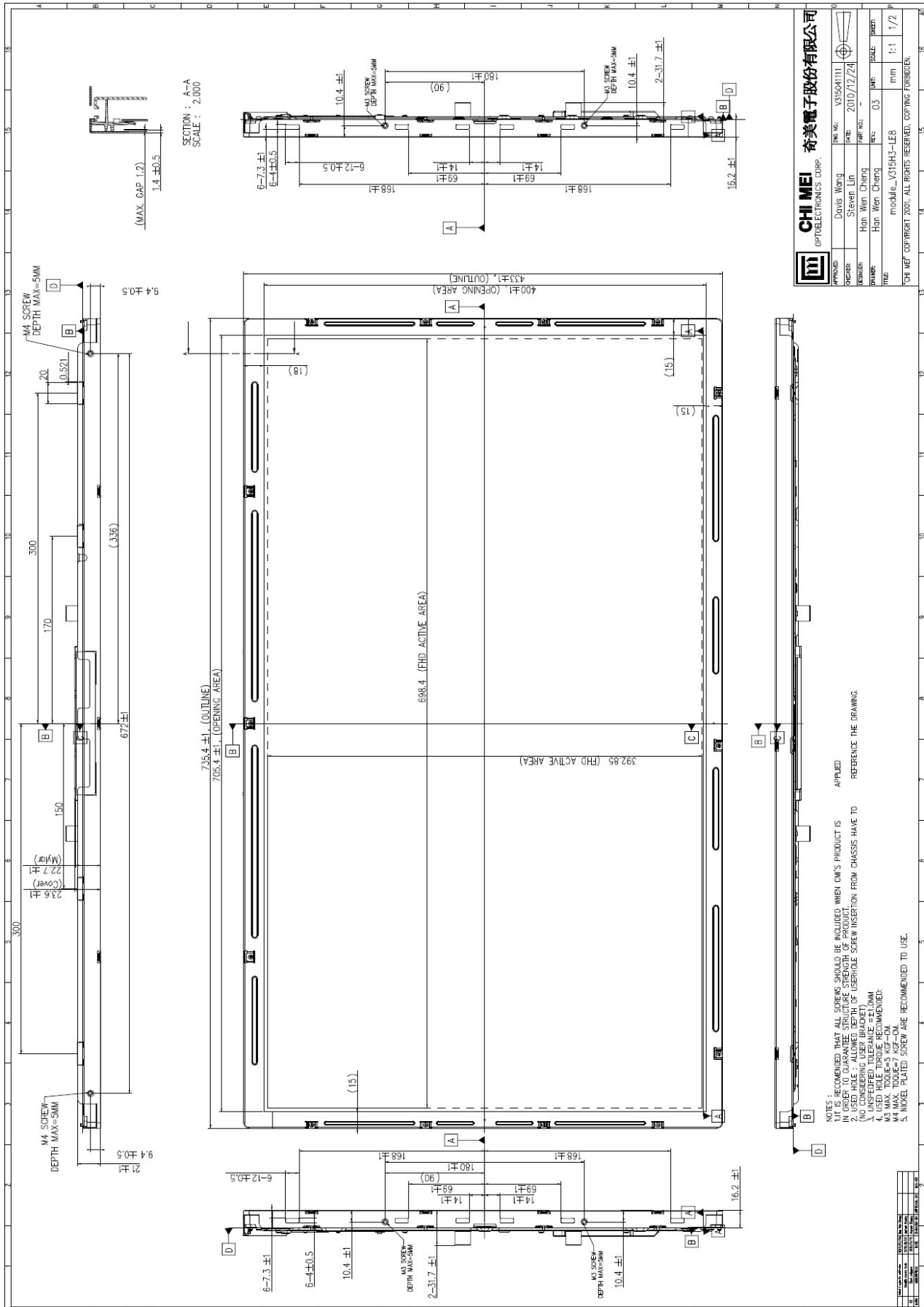

Version 2.1

40

Date : Mar. 09, 2011

The copyright belongs to CHIMEI InnoLux. Any unauthorized use is prohibited

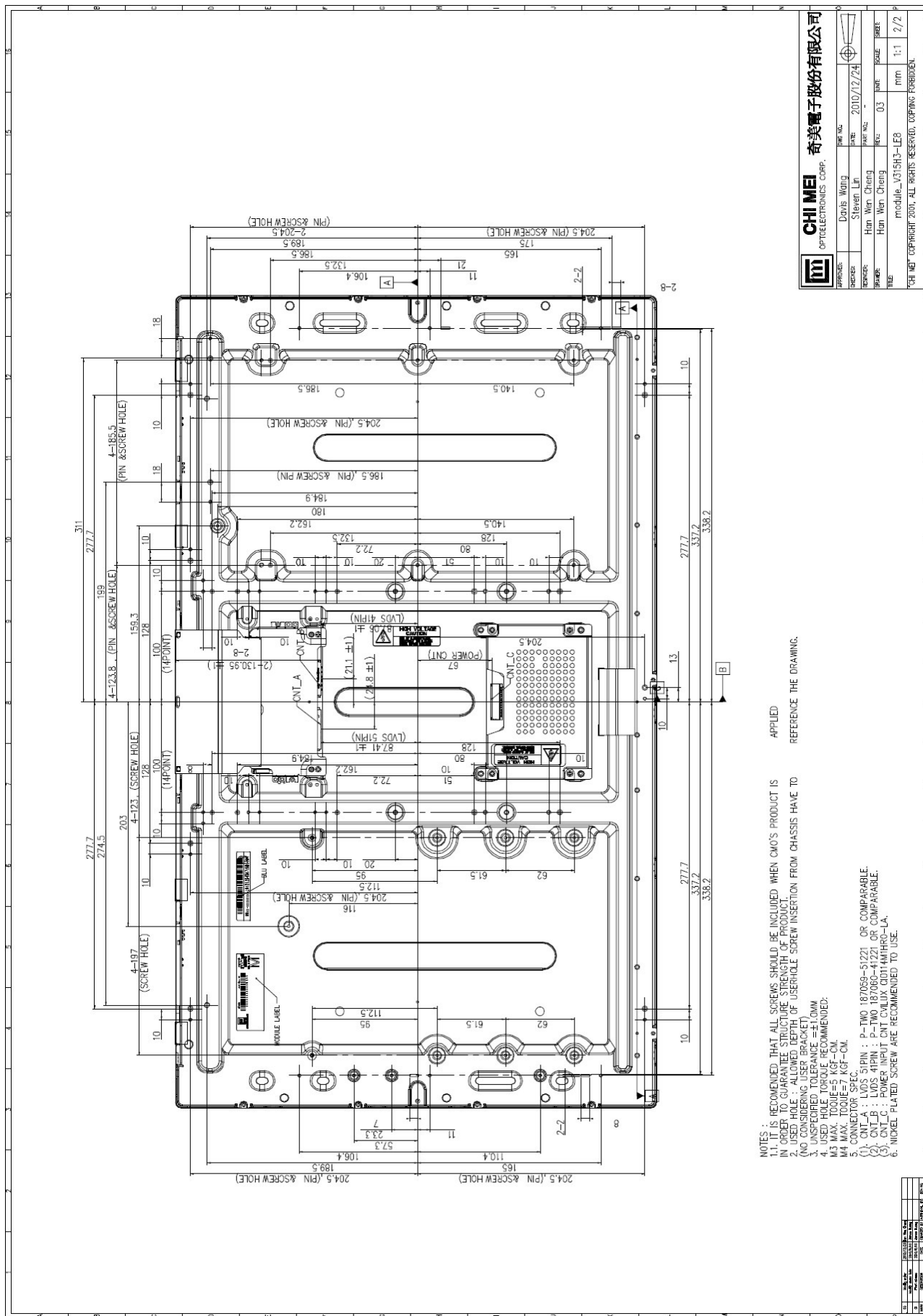

CHI MEI OPTOELECTRONICS CORP.		REV. NO.	2010/12/24
DESIGNED	Davis Wang	DATE	2010/12/24
DRAWN	Steven Lin	PROJ. NO.	
CHECKED	Han Wen Cheng	REV.	03
DATE	Han Wen Cheng	UNIT	mm
TITLE	module_V015H3-LEB	SCALE	1:1
		SHEET	2/2

CHI MEI COPYRIGHT 2001. ALL RIGHTS RESERVED. COPYING FORBIDDEN.

NOTES : IS RECOMMENDED THAT ALL SCREWS SHOULD BE INCLUDED WHEN CHM'S PRODUCT IS APPLIED.
 1. USED HOLE ALLOWED DEPTH OF USE INSOLE SCREW INSERTION FROM CHASSIS HOLE TO REFERENCE THE DRAWING.
 2. USED HOLE ALLOWED DEPTH OF USE INSOLE SCREW INSERTION FROM CHASSIS HOLE TO REFERENCE THE DRAWING.
 3. UNSPECIFIED TOLERANCE = ±0.0MM
 4. USED HOLE TORQUE RECOMMENDED:
 M3 MAX. TORQUE=5 KGF-CM.
 M4 MAX. TORQUE=7 KGF-CM.
 5. CONNECTOR SPEC. PIN : P-TWO 187050-51221 OR COMPARABLE.
 6. CNT.B : LVDS 4PIN : P-TWO 187060-41221 OR COMPARABLE.
 7. CNT.C : POWER INPUT CNT CMIUX.C0114M1HRO-LA.
 8. NICKEL-PLATED SCREW ARE RECOMMENDED TO USE.

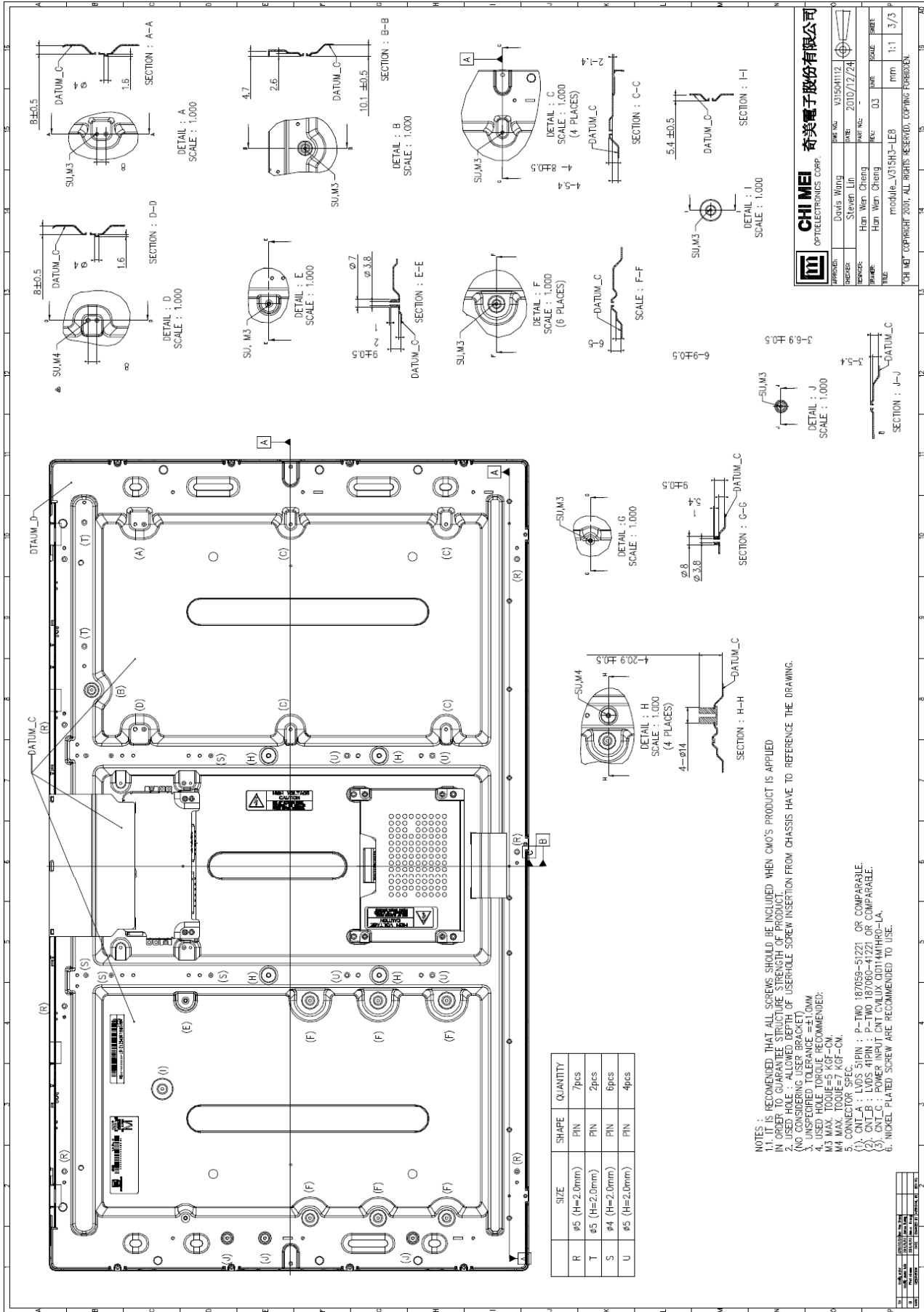

CHI MEI OPTOELECTRONICS CORP.			
APPROVER:	DAVIS WANG	DATE:	V31504112
DRAWER:	STEVEN LIN	DATE:	2010/12/24
ENGINEER:	HAN WEN CHENG	SCALE:	0.3
DATE:	HAN WEN CHENG	SCALE:	1:1
FILE:	middle_V315H3-LE3	SCALE:	3/3
"CHI MEI" COPYRIGHT 2010, ALL RIGHTS RESERVED. DRAFTING FORBIDDEN.			

SIZE	SHAPE	QUANTITY
R	#5 (H=2.0mm)	7pcs
T	#5 (H=2.0mm)	2pcs
S	#4 (H=2.0mm)	6pcs
U	#5 (H=2.0mm)	4pcs

NOTES :

1. IT IS RECOMMENDED THAT ALL SCREWS SHOULD BE INCLUDED WHEN CMO'S PRODUCT IS APPLIED IN ORDER TO GUARANTEE STRUCTURE STRENGTH OF PRODUCT.
2. USED HOLE : ALLOWED DEPTH OF USERHOLE SCREW INSERTION FROM CHASSIS HAVE TO REFERENCE THE DRAWING.
3. (NO) CONSIDERING USER BRACKET/CMO
4. USED HOLE TORQUE RECOMMENDED:
- M3 MAX. TORQUE=5 KGF-CM
- M4 MAX. TORQUE=7 KGF-CM
5. CONNECTOR SPEC.
- (1) CNT-A : LVDS 5PIN : P-TWO 187059-51221 OR COMPAREBLE.
- (2) CNT-B : LVDS 4PIN : P-TWO 187000-41221 OR COMPAREBLE.
- (3) CNT-C : LVDS 5PIN : P-TWO 187000-51221 OR COMPAREBLE.
6. NICKEL PLATED SCREW ARE RECOMMENDED TO USE.