

TFT LCD Tentative Specification

MODEL NO.: V370H3 – LH4

Approved By	TVHD	
	LY Chen	
Reviewed By	QA Dept.	Product Development Div.
	Kc-Ko	WT Lin
Prepared By	LCD TV Marketing and Product Management Div.	
	WY Li	Chloe Chen

- CONTENTS -

REVISION HISTORY	-----	3
1. GENERAL DESCRIPTION	-----	4
1.1 OVERVIEW		
1.2 FEATURES		
1.3 APPLICATION		
1.4 GENERAL SPECIFICATIONS		
1.5 MECHANICAL SPECIFICATIONS		
2. ABSOLUTE MAXIMUM RATINGS	-----	5
2.1 ABSOLUTE RATINGS OF ENVIRONMENT		
2.2 PACKAGE STORAGE		
2.3 ELECTRICAL ABSOLUTE RATINGS		
2.3.1 TFT LCD MODULE		
2.3.2 BACKLIGHT UNIT		
3. ELECTRICAL CHARACTERISTICS	-----	7
3.1 TFT LCD MODULE		
3.2 BACKLIGHT UNIT		
3.2.1 CCFL(Cold Cathode Fluorescent Lamp) CHARACTERISTICS		
3.2.2 INVERTER CHARACTERISTICS		
3.2.3 INVERTER INTERFACE CHARACTERISTICS		
4. BLOCK DIAGRAM	-----	13
4.1 TFT LCD MODULE		
5. INTERFACE PIN CONNECTION	-----	14
5.1 TFT LCD MODULE		
5.2 BACKLIGHT UNIT		
5.3 INVERTER UNIT		
5.4 BLOCK DIAGRAM OF INTERFACE		
5.5 LVDS INTERFACE		
5.6 COLOR DATA INPUT ASSIGNMENT		
6. INTERFACE TIMING	-----	23
6.1 INPUT SIGNAL TIMING SPECIFICATIONS		
6.2 POWER ON/OFF SEQUENCE		
7. OPTICAL CHARACTERISTICS	-----	26
7.1 TEST CONDITIONS		
7.2 OPTICAL SPECIFICATIONS		
8. DEFINITION OF LABELS	-----	30
8.1 CMO MODULE LABEL		
9. PACKAGING	-----	31
9.1 PACKING SPECIFICATIONS		
9.2 PACKING METHOD		
10. PRECAUTIONS	-----	33
10.1 ASSEMBLY AND HANDLING PRECAUTIONS		
10.2 SAFETY PRECAUTIONS		
10.3 SAFETY STANDARDS		
11. MECHANICAL CHARACTERISTICS	-----	34

REVISION HISTORY

Version	Date	Page (New)	Section	Description
Ver 1.0	Apr. 17,'09	All	All	Tentative Specification was first issued.

1. GENERAL DESCRIPTION

1.1 OVERVIEW

V370H4 - LH1 is a 37" TFT Liquid Crystal Display module with 10-CCFL Backlight unit and 2ch-LVDS interface. This module supports 1920 x 1080 FHD format and can display true 1.0G colors (10-bit/color). The inverter module for backlight is built-in.

1.2 FEATURES

- High brightness (450 nits)
- Ultra-high contrast ratio (4000:1)
- Faster response time (Gray to gray average 4ms)
- High color saturation NTSC 72%
- Ultra wide viewing angle : 176(H)/176(V) (CR>20) with Super MVA technology
- DE (Data Enable) only mode
- LVDS (Low Voltage Differential Signaling) interface
- Color reproduction (nature color)
- Optimized response time for 120 Hz Frame rate
- Low color shift function
- RoHS compliance

1.3 APPLICATION

- TFT LCD TVs
- Multi-Media Display

1.4 GENERAL SPECIFICATIONS

Item	Specification	Unit	Note
Active Area	819.36(H) x 460.89 (V) (37" diagonal)	mm	(1)
Bezel Opening Area	828.6 (H) x 469.8 (V)	mm	
Driver Element	a-si TFT active matrix	-	
Pixel Number	1920 x R.G.B. x 1080	pixel	
Pixel Pitch (Sub Pixel)	0.2(H) x 0.6 (V)	mm	
Pixel Arrangement	RGB vertical stripe	-	
Display Colors	1.0G	color	
Display Operation Mode	Transmissive mode / Normally black	-	
Surface Treatment	Glare type, Hard coating (3H)	-	

1.5 MECHANICAL SPECIFICATIONS

Item	Min.	Typ.	Max.	Unit	Note	
Module Size	Horizontal(H)	876	877	878	mm	(1)
	Vertical(V)	516	516.8	517.6	mm	(1)
	Depth(D)	35.4	36.4	37.4	mm	To TOP Side
	Depth(D)	50.4	51.4	52.4	mm	To PCB Cover
	Depth(D)	55	53	54	mm	To Inv Cover
Weight	-	7865	-	g		

Note (1) Please refer to the attached drawings for more information of front and back outline dimensions.

2. ABSOLUTE MAXIMUM RATINGS

2.1 ABSOLUTE RATINGS OF ENVIRONMENT

Item	Symbol	Value		Unit	Note
		Min.	Max.		
Storage Temperature	T _{ST}	-20	+60	°C	(1)
Operating Ambient Temperature	T _{OP}	0	+50	°C	(1), (2)
Shock (Non-Operating)	S _{NOF}	-	50	G	(3), (5)
Vibration (Non-Operating)	V _{NOF}	-	1.0	G	(4), (5)

Note (1) Temperature and relative humidity range is shown in the figure below.

(a) 90 %RH Max. ($T_a \leq 40$ °C).

(b) Wet-bulb temperature should be 39 °C Max. ($T_a > 40$ °C).

(c) No condensation.

Note (2) The maximum operating temperature is based on the test condition that the surface temperature of display area is less than or equal to 65 °C with LCD module alone in a temperature controlled chamber. Thermal management should be considered in final product design to prevent the surface temperature of display area from being over 65 °C. The range of operating temperature may degrade in case of improper thermal management in final product design.

Note (3) 11 ms, half sine wave, 1 time for $\pm X$, $\pm Y$, $\pm Z$.

Note (4) 10 ~ 200 Hz, 10 min, 1 time each X, Y, Z.

Note (5) At testing Vibration and Shock, the fixture in holding the module has to be hard and rigid enough so that the module would not be twisted or bent by the fixture.

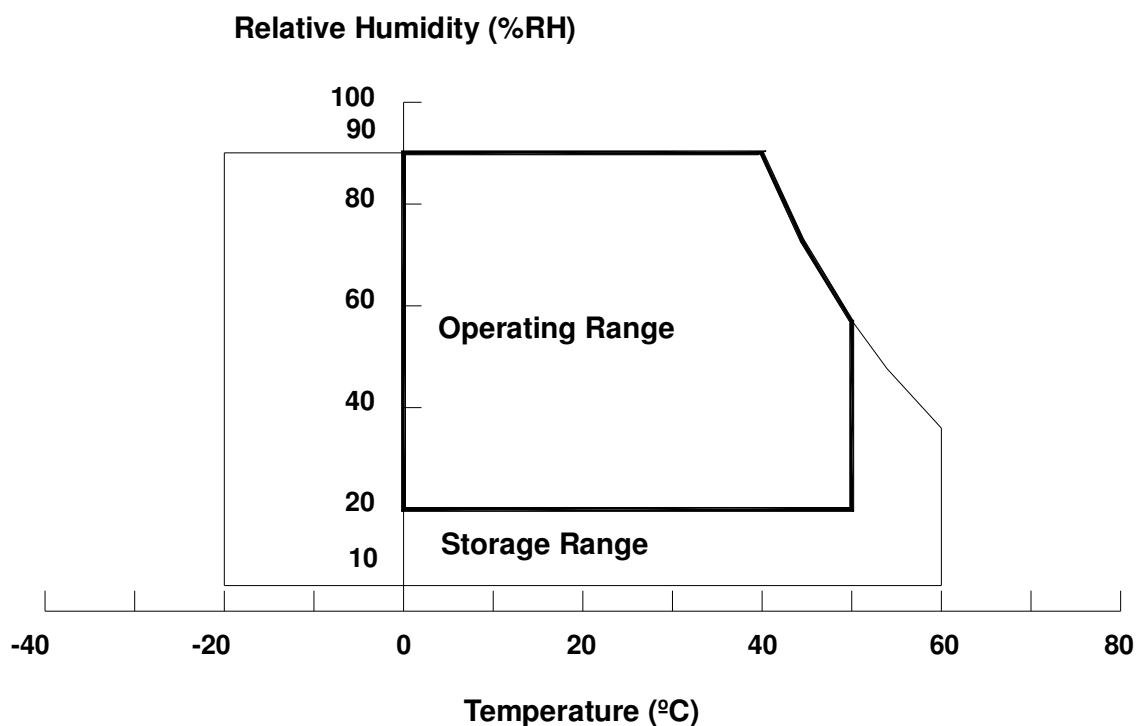

2.2 PACKAGE STORAGE

When storing modules as spares for a long time, the following precaution is necessary.

- Do not leave the module in high temperature, and high humidity for a long time. It is highly recommended to store the module with temperature from 0 to 35 °C at normal humidity without condensation.
- The module shall be stored in dark place. Do not store the TFT-LCD module in direct sunlight or fluorescent light.

2.3 ELECTRICAL ABSOLUTE RATINGS

2.3.1 TFT LCD MODULE

Item	Symbol	Value		Unit	Note
		Min.	Max.		
Power Supply Voltage	V _{CC}	-0.3	13.5	V	(1)
Input Signal Voltage	V _{IN}	-0.3	3.6	V	

2.3.2 BACKLIGHT INVERTER UNIT

Item	Symbol	Value		Unit	Note
		Min.	Max.		
Lamp Voltage	V _W	—	3000	V _{RMS}	
Power Supply Voltage	V _{BL}	0	30	V	(1)
Control Signal Level	—	-0.3	7	V	(1), (3)

Note (1) Permanent damage to the device may occur if maximum values are exceeded. Function operation should be restricted to the conditions described under Normal Operating Conditions.

Note (2) No moisture condensation or freezing.

Note (3) The control signals include On/Off Control, Internal PWM Control, External PWM Control.

3. ELECTRICAL CHARACTERISTICS

3.1 TFT LCD MODULE

Parameter		Symbol	Value			Unit	Note
			Min.	Typ.	Max.		
Power Supply Voltage		VCC	10.8	12	13.2	V	(1)
Power Supply Ripple Voltage		VRP	-	-	350	mV	
Rush Current		IRUSH	-	-	5.0	A	(2)
Power Supply Current		White Pattern	-	1.7	-	A	(3)
		Vertical Stripe	-	2.4	2.9	A	
		Black Pattern	-	1.6	-	A	
LVDS interface	Common Input Voltage	VLVC	1.125	1.25	1.375	V	
	Terminating Resistor	RT	-	100	-	ohm	
CMOS interface	Input High Threshold Voltage	VIH	2.7	-	3.3	V	
	Input Low Threshold Voltage	VIL	0	-	0.7	V	

Note (1) The module should be always operated within above ranges.

Note (2) Measurement Conditions:

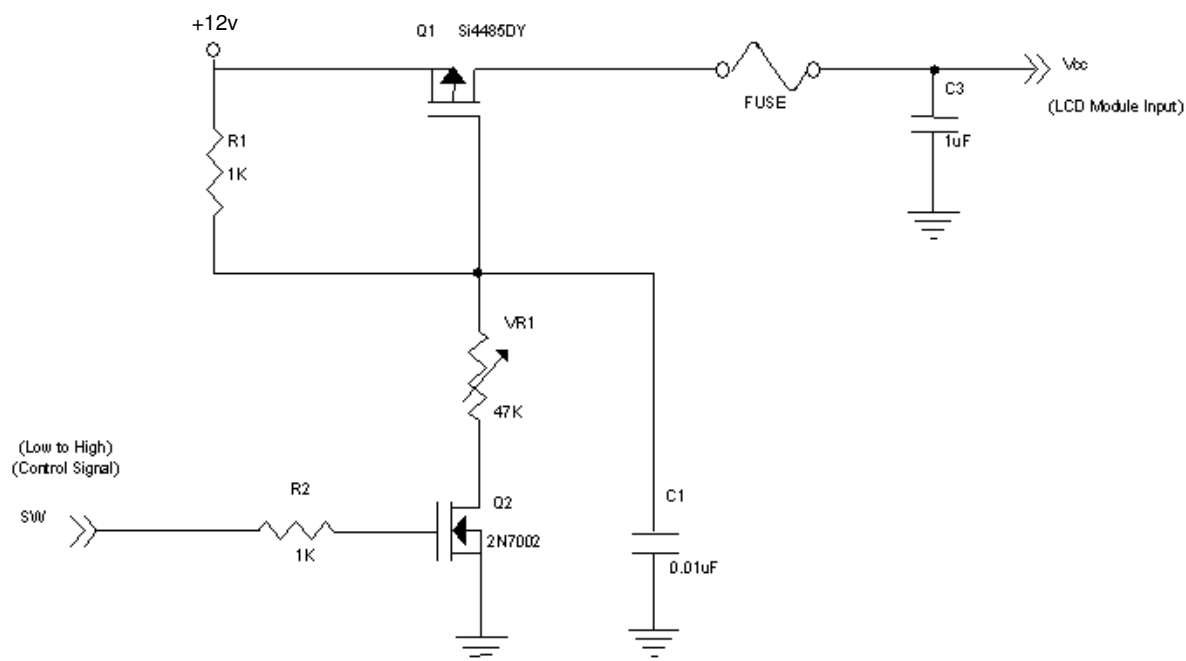

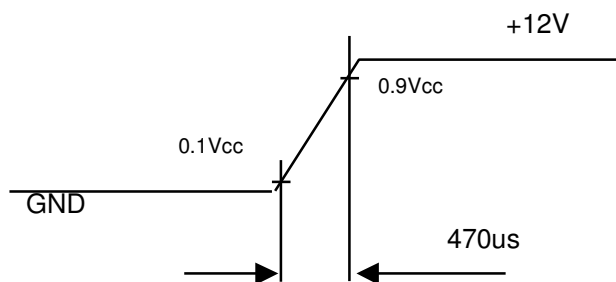
Vcc rising time is 470us

Note (3) The specified power supply current is under the conditions at $V_{cc} = 12\text{ V}$, $T_a = 25 \pm 2\text{ }^\circ\text{C}$, $f_v = 60\text{ Hz}$, whereas a power dissipation check pattern below is displayed.

a. White Pattern



Active Area

b. Black Pattern



Active Area

c. Vertical Stripe Pattern

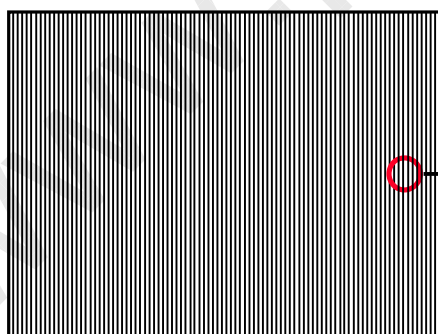

Active Area

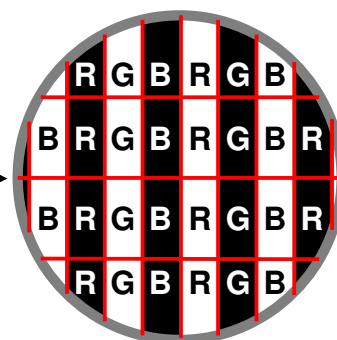

3.2 BACKLIGHT UNIT

3.2.1 CCFL (Cold Cathode Fluorescent Lamp) CHARACTERISTICS (Ta = 25 ± 2 °C)

Parameter	Symbol	Value			Unit	Note
		Min.	Typ.	Max.		
Lamp Voltage	V _W	-	940	-	VRMS	
Lamp Current	I _L	11.7	12.0	12.3	mA _{RMS}	(1)
Lamp Starting Voltage	V _S	-	-	1730	V _{RMS}	Ta = 0 °C (2)
		-	-	1340	V _{RMS}	Ta = 25 °C (2)
Operating Frequency	F _O	30	-	80	KHz	
Lamp Life Time	L _{BL}	50,000	-	-	Hrs	(4)

3.2.2 INVERTER CHARACTERISTICS (Ta = 25 ± 2 °C)

Parameter	Symbol	Value			Unit	Note
		Min.	Typ.	Max.		
Power Consumption	P _{BL}	-	86.4	90	W	(5) (6) I _L = 8.6mA
Power Supply Voltage	V _{BL}	22.8	24	25.2	V _{DC}	
Power Supply Current	I _{BL}	-	3.6	3.75	A	Non Dimming
Input Ripple Noise	--	-	-	912	mV _{P-P}	V _{BL} = 22.8V
Oscillating Frequency	F _W	37.0	40.0	43.0	kHz	(3)
Dimming Frequency	F _B	150	160	170	Hz	
Minimum Duty Ratio	D _{MIN}		20	-	%	

Note (1) Lamp current is measured by utilizing high frequency current meters as shown below:

Note (2) The lamp starting voltage V_S should be applied to the lamp for more than 1 second after startup. Otherwise the lamp may not be turned on.

Note (3) The lamp frequency may produce interference with horizontal synchronous frequency of the display input signals, and it may result in line flow on the display. In order to avoid interference, the lamp frequency should be detached from the horizontal synchronous frequency and its harmonics as far as possible.

Note (4) The life time of a lamp is defined as when the brightness is larger than 50% of its original value and the effective discharge length is longer than 80% of its original length (Effective discharge length is defined as an area that has equal to or more than 70% brightness compared to the brightness at the center point of lamp.) as the time in which it continues to operate under the condition at Ta = 25 ± 2°C and I_L = 8.1~9.1 mA_{RMS}.

Note (5) The power supply capacity should be higher than the total inverter power consumption P_{BL}. Since the pulse width modulation (PWM) mode was applied for backlight dimming, the driving current changed as PWM duty on and off. The transient response of power supply should be considered for the changing loading when inverter dimming.

Note (6) The measurement of Max. value is based on 37" backlight unit under 24V input voltage and 9.1 mA lamp in average after lighting for 30 minutes.

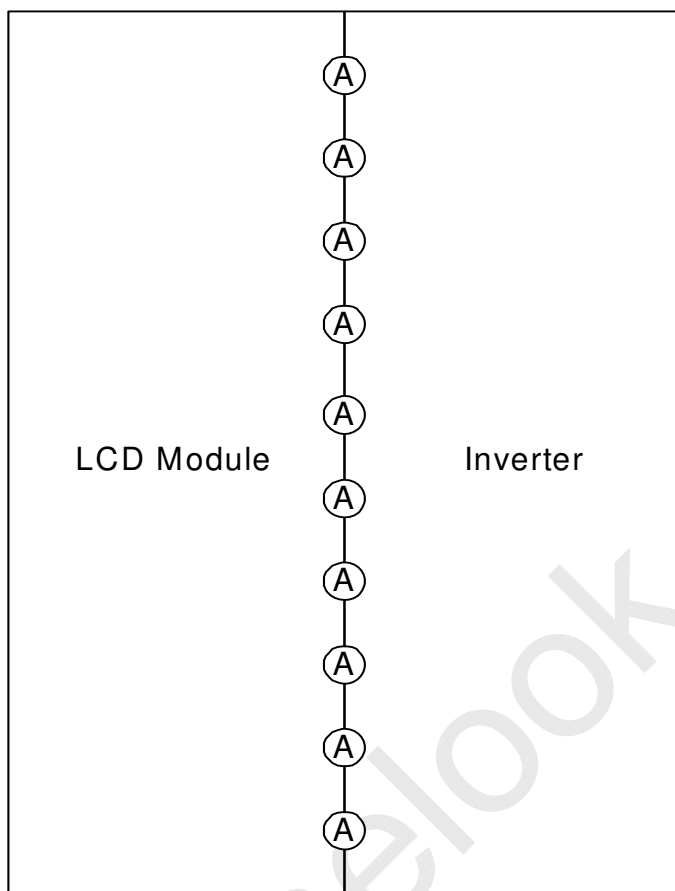

www.panelook.com

3.2.3 INVERTER INTERFACE CHARACTERISTICS

Parameter		Symbol	Test Condition	Value			Unit	Note
				Min.	Typ.	Max.		
On/Off Control Voltage	ON	V_{BLON}	—	2.0	—	5.0	V	
	OFF		—	0	—	0.8	V	
Internal PWM Control Voltage	MAX	V_{IPWM}	—	3.15	3.3	3.45	V	Maximum duty ratio
	MIN		—	—	0	—	V	Minimum duty ratio
External PWM Control Voltage	HI	V_{EPWM}	—	2.0	—	5.0	V	Duty on
	LO		—	0	—	0.8	V	Duty off
Status Signal	HI	Status	—	3.0	3.3	3.6	V	Normal
	LO		—	0	—	0.8	V	Abnormal
VBL Rising Time		T_{r1}	—	30	—	—	ms	10%-90% V_{BL}
VBL Falling Time		T_{f1}	—	30	—	—	ms	
Control Signal Rising Time		T_r	—	—	—	100	ms	
Control Signal Falling Time		T_f	—	—	—	100	ms	
PWM Signal Rising Time		T_{PWMR}	—	—	—	50	us	
PWM Signal Falling Time		T_{PWMF}	—	—	—	50	us	
Input impedance		R_{IN}	—	1	—	—	MΩ	
PWM Delay Time		T_{PWM}	—	100	—	—	ms	
BLON Delay Time	T_{on}	—	—	300	—	—	ms	
	T_{on1}	—	—	300	—	—	ms	
BLON Off Time		T_{off}	—	300	—	—	ms	

Note (1) The Dimming signal should be valid before backlight turns on by BLON signal. It is inhibited to change the internal/external PWM signal during backlight turn on period.

Note (2) The power sequence and control signal timing are shown in the following figure. For a certain reason, the inverter has a possibility to be damaged with wrong power sequence and control signal timing.

Note (3) While system is turned ON or OFF, the power sequences must follow as below descriptions:

Turn ON sequence: VBL → PWM signal → BLON

Turn OFF sequence: BLOFF → PWM signal → VBL

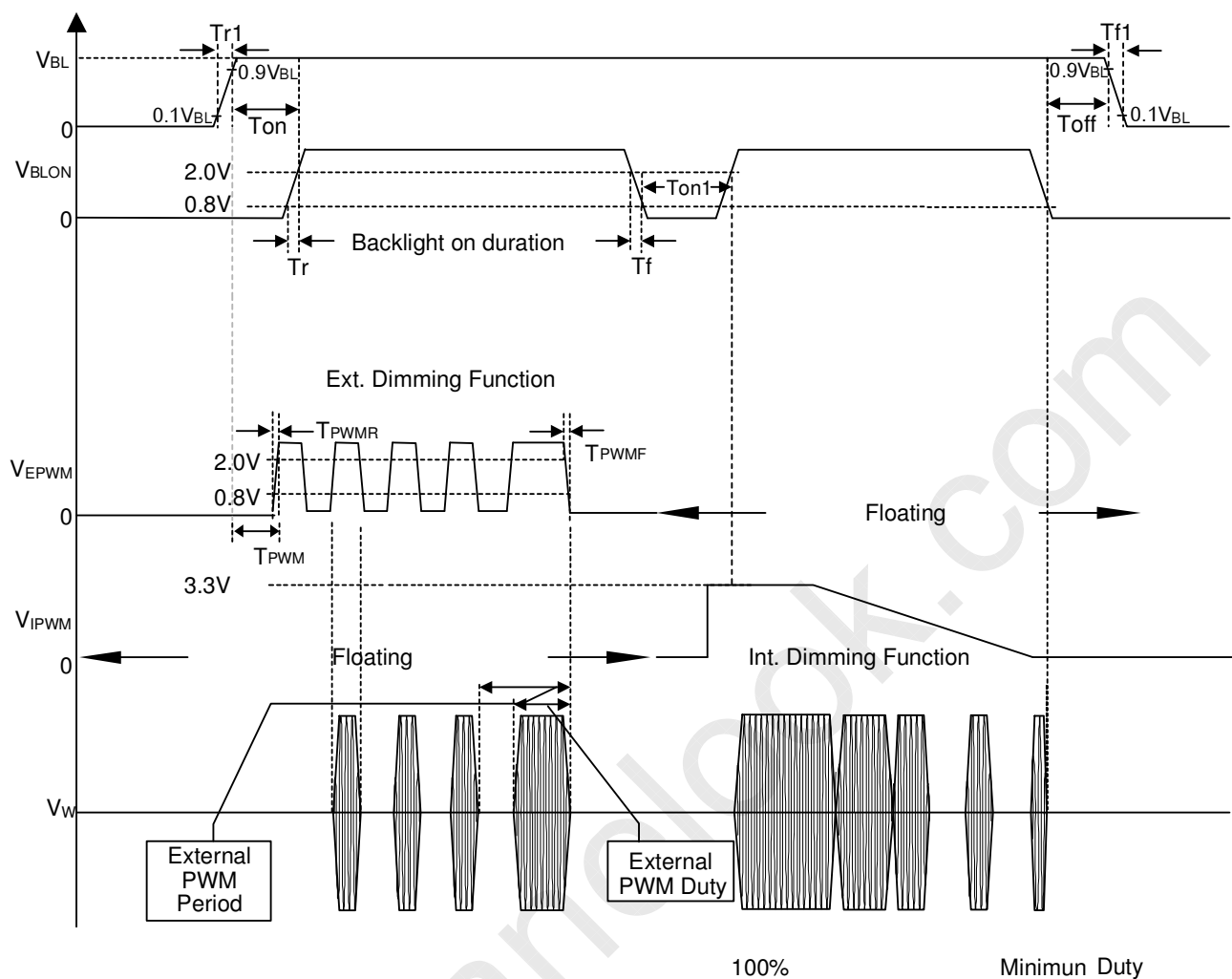



4. BLOCK DIAGRAM

4.1 TFT LCD MODULE

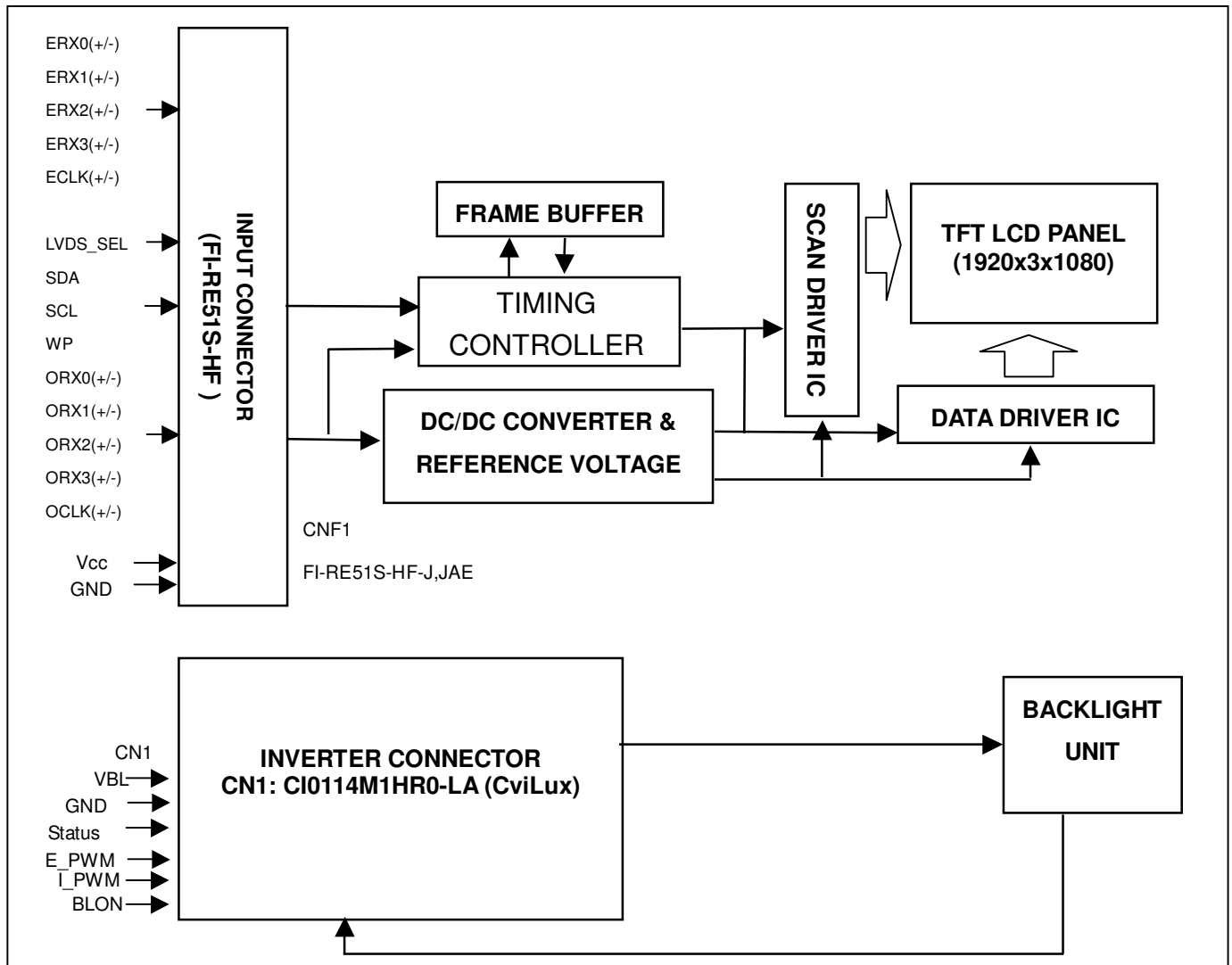

5. INTERFACE PIN CONNECTION

5.1 TFT LCD Module Input

CNF1 Connector Part No.: JAE Taiwan FI-RE51S-HF or equal.

Pin	Name	Description	Note
1	GND	Ground	
2	MEN	MEMC function selection	5
3	MCFG0	MEMC function selection	5
4	MCFG1	MEMC function selection	5
5	LVDS8b	8bit/10bit LVDS input selection	6
6	GV_mode	Graphic / Video mode selection	7
7	SELLVDS	LVDS data format Selection	3
8	Res.	No Connection	
9	Res.	No Connection	
10	ODSEL	Overdrive Lookup Table Selection	4
11	GND	Ground	
12	ERX0-	2nd pixel Negative LVDS differential data input. Channel 0	
13	ERX0+	2nd pixel Positive LVDS differential data input. Channel 0	
14	ERX1-	2nd pixel Negative LVDS differential data input. Channel 1	
15	ERX1+	2nd pixel Positive LVDS differential data input. Channel 1	
16	ERX2-	2nd pixel Negative LVDS differential data input. Channel 2	
17	ERX2+	2nd pixel Positive LVDS differential data input. Channel 2	
18	GND	Ground	
19	ECLK-	2nd pixel Negative LVDS differential clock input.	
20	ECLK+	2nd pixel Positive LVDS differential clock input.	
21	GND	Ground	
22	ERX3-	2nd pixel Negative LVDS differential data input. Channel 3	
23	ERX3+	2nd pixel Positive LVDS differential data input. Channel 3	
24	ERX4-	2nd pixel Negative LVDS differential data input. Channel 4	
25	ERX4+	2nd pixel Positive LVDS differential data input. Channel 4	
26	N.C.	No Connection	1
27	N.C.	No Connection	1
28	ORX0-	1st pixel Negative LVDS differential data input. Channel 0	
29	ORX0+	1st pixel Positive LVDS differential data input. Channel 0	
30	ORX1-	1st pixel Negative LVDS differential data input. Channel 1	
31	ORX1+	1st pixel Positive LVDS differential data input. Channel 1	
32	ORX2-	1st pixel Negative LVDS differential data input. Channel 2	

33	ORX2+	1st pixel Positive LVDS differential data input. Channel 2	
34	GND	Ground	
35	OCLK-	1st pixel Negative LVDS differential clock input.	
36	OCLK+	1st pixel Positive LVDS differential clock input.	
37	GND	Ground	
38	ORX3-	1st pixel Negative LVDS differential data input. Channel 3	
39	ORX3+	1st pixel Positive LVDS differential data input. Channel 3	
40	ORX4-	1st pixel Negative LVDS differential data input. Channel 4	
41	ORX4+	1st pixel Positive LVDS differential data input. Channel 4	
42	N.C.	No Connection	1
43	N.C.	No Connection	1
44	GND	Ground	
45	GND	Ground	
46	GND	Ground	
47	N.C.	No Connection	
48	VCC	+12V power supply	
49	VCC	+12V power supply	
50	VCC	+12V power supply	
51	VCC	+12V power supply	

Note (1) Reserved for internal use. Please leave it open.

Note (2) Low= Connect to GND, High = Connect to +3.3V

Note (3)

L	VESA
H	JEIDA

Note (4) Overdrive lookup table selection. The overdrive lookup table should be selected in accordance with the frame rate to optimize image quality.

ODSEL	Note
L	Lookup table was optimized for 60 Hz frame rate input.
H	Lookup table was optimized for 50 Hz frame rate input.

Note (5) Motion Engine Level & Demo Function Table

Motion engine level could be adjusted after video mode enabling.

ME Level	MEN	MCFG1	MCFG0	De blur	De judder	Halo
Blanking disable	0	0	0	(a)		
Auto blanking	0	0	1	(b)		
Blanking enable	0	1	0	(c)		
Demo mode	0	1	1	Demo Window		
STRONG	1	0	0	Enable	Strong	Strong
NORMAL(default)	1	0	1	Enable	Normal	Normal
WEAK	1	1	0	Enable	×	×
OFF	1	1	1	×		

(a) Module re-start to process (for Frontend scaler control).

(b) For format change, ex: 60 <-> 50sync unstable. MCFG0 is received a toggle signal. Blanking will keep 500ms.

(c) Module will wait the blanking disable notice from frontend scaler board.

(d) GPIO sequence of ME Level: (1) MEN; (2) MCFG1; (3) MCFG0.

GPIO sequence of Blanking Enable, Blanking Disable and Demo window: (1) MCFG1; (2) MCFG0; (3) MEN.

(e) Each scaler command must at least keep 100ms.

Note (6) 8bit/10bit LVDS input selection

LVDS8b	
H(default)	8bit
L	10bit

Note (7) Graphic / Video mode selection

This function is always detection , when switch the mode, the chip will be reset to perform it

GV_mode	
H(default)	Graphic mode
L	Video mode

5.2 BACKLIGHT UNIT

The pin configuration for the housing and leader wire is shown in the table below.

Pin No.	Symbol	Description	Remark
NA	NA	NA	NA

Note (1) The backlight interface housing for high voltage side is a model CPLEA4C1000, manufactured by CVILUX or equivalent.



5.3 INVERTER UNIT

CN1 (Header): CI0114M1HR0-LA (CviLux)

Pin No.	Symbol	Description
1	VBL	+24V Power input
2		
3		
4		
5		
6	GND	Ground
7		
8		
9		
10		
11	Status	Normal (3.3V) Abnormal (0V)
12	E_PWM	External PWM Control
13	I_PWM	Internal PWM Control
14	BLON	BL ON/OFF

Notice:

Note (1) PIN 12:External PWM Control (Use Pin 12): Pin 13 must open.

Note (2) PIN 13:Internal PWM Control (Use Pin 13): Pin 12 must open.

Note (3) Pin 12(E_PWM) and Pin 13(I_PWM) can't open in same period.

5.4 BLOCK DIAGRAM OF INTERFACE

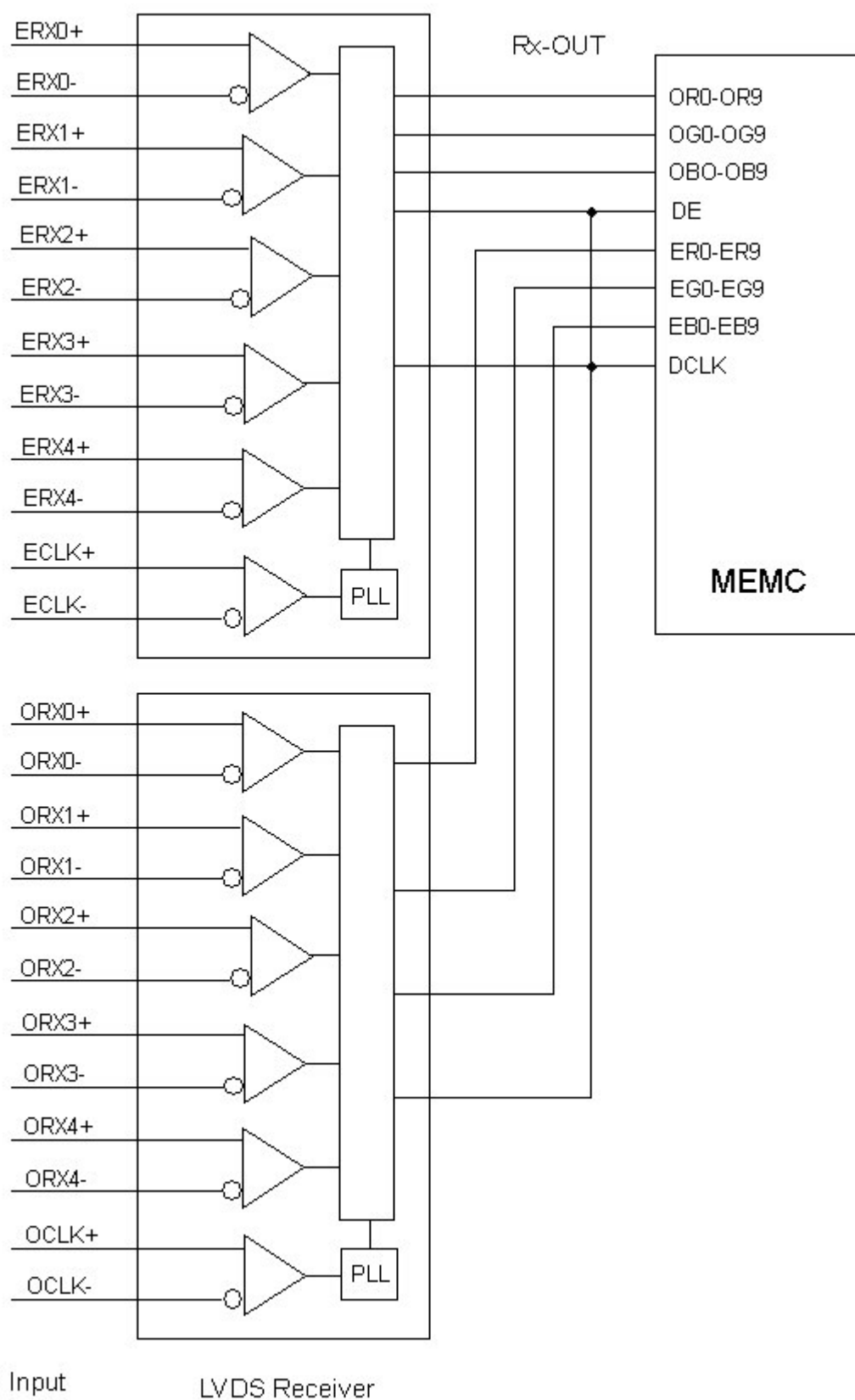

AR0~AR9: First pixel R data

AG0~AG9: First pixel G data

AB0~AB9: First pixel B data

BR0~BR9: Second pixel R data

BG0~BG9: Second pixel G data

BB0~BB9: Second pixel B data

DE: Data enable signal

DCLK: Data clock signal

Notes (1) The system must have the transmitter to drive the module.

Notes (2) LVDS cable impedance shall be 50 ohms per signal line or about 100 ohms per twist-pair line when it is used differentially.

Notes (3) Two pixel data send into the module for every clock cycle. The first pixel of the frame is odd pixel and the second pixel is even pixel.

5.5 LVDS INTERFACE

VESA Format : SELLVDS = L or Open

JEIDA Format : SELLVDS = H

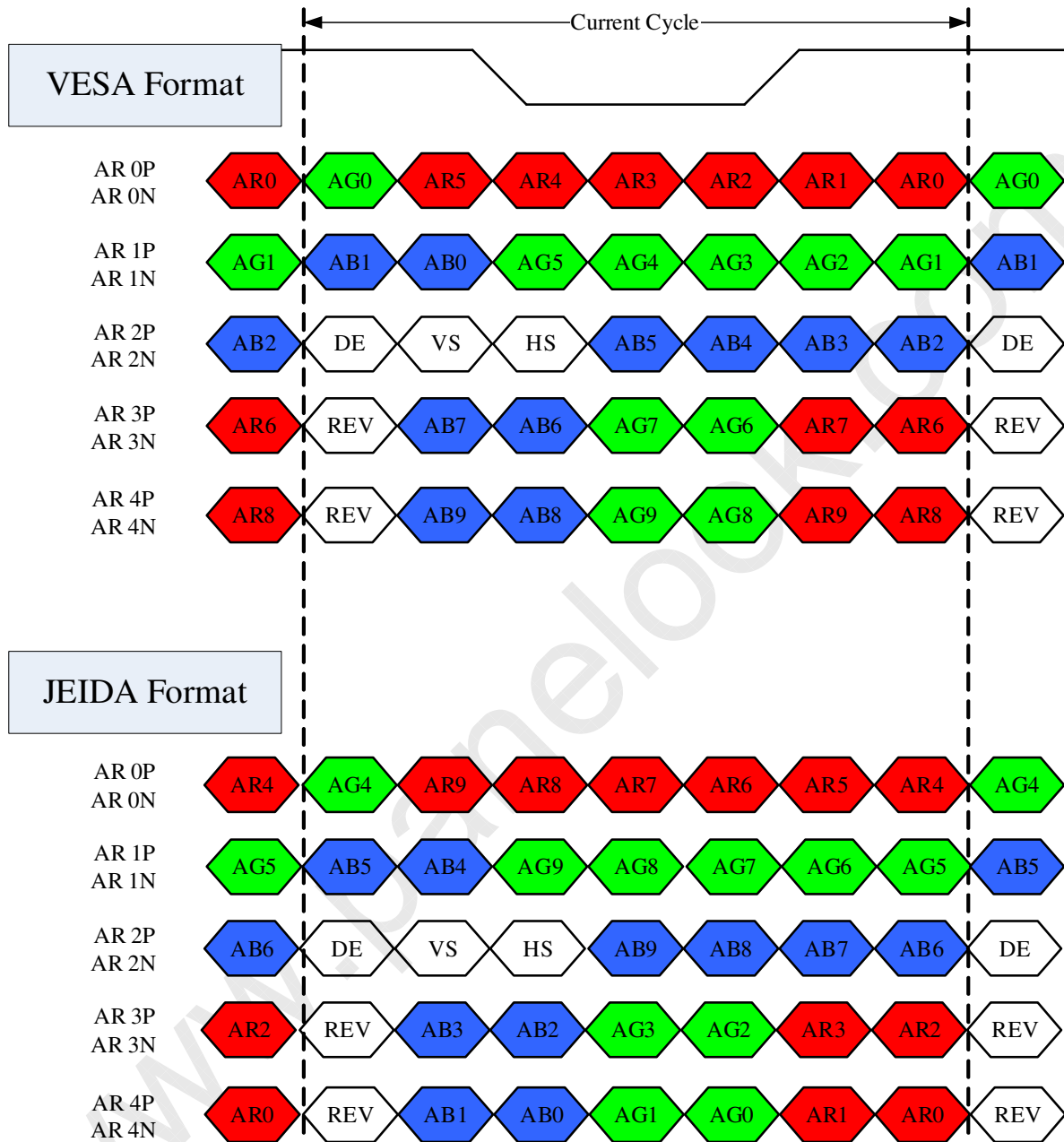

AR0~AR9: First Pixel R Data (9; MSB, 0; LSB)

AG0~AG9: First Pixel G Data (9; MSB, 0; LSB)

AB0~AB9: First Pixel B Data (9; MSB, 0; LSB)

DE : Data enable signal

DCLK : Data clock signal

RSVD : Reserved

6. INTERFACE TIMING

6.1 INPUT SIGNAL TIMING SPECIFICATIONS

($T_a = 25 \pm 2 \text{ }^\circ\text{C}$)

The input signal timing specifications are shown as the following table and timing diagram.

Signal	Item	Symbol	Min.	Typ.	Max.	Unit	Note
LVDS Receiver Clock	Frequency	1/Tc	60	74.25	78	MHz	-
	Input cycle to cycle jitter	Trcl	-	-	200	ps	-
LVDS Receiver Data	Setup Time	Tlvsu	600	-	-	ps	-
	Hold Time	Tlvhd	600	-	-	ps	-
Vertical Active Display Term	Frame Rate		-	120	-	Hz	
	Total	Tv	1115	1125	1135	Th	$T_v = T_{vd} + T_{vb}$
	Display	Tvd	1080	1080	1080	Th	-
	Blank	Tvb	35	45	55	Th	-
Horizontal Active Display Term	Total	Th	1050	1100	1150	Tc	$T_h = T_{hd} + T_{hb}$
	Display	Thd	960	960	960	Tc	-
	Blank	Thb	90	140	190	Tc	-

Note : Since the module is operated in DE only mode, Hsync and Vsync input signals should be set to low logic level. Otherwise, this module would operate

INPUT SIGNAL TIMING DIAGRAM

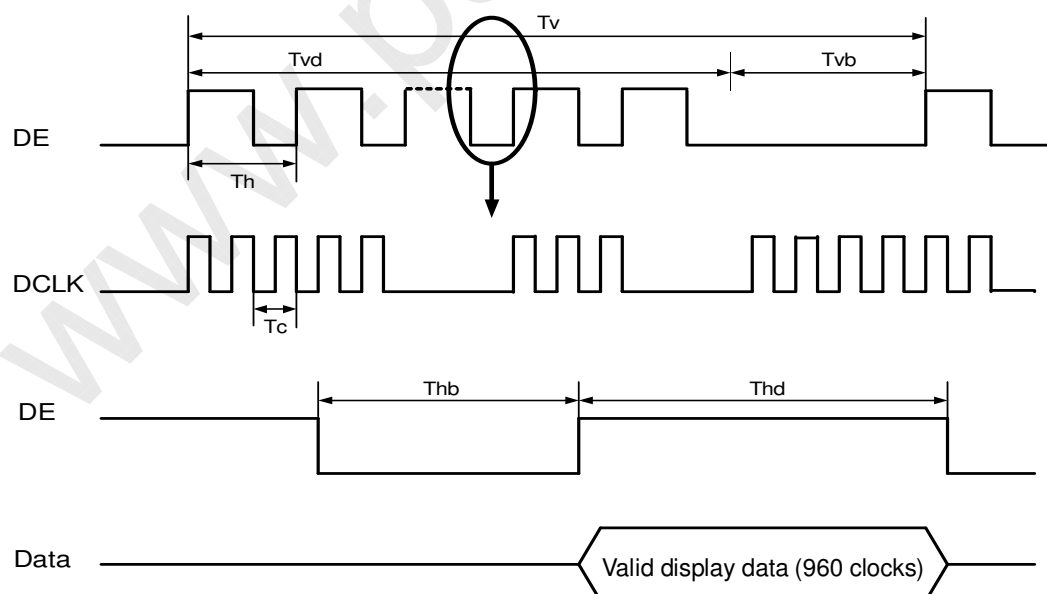

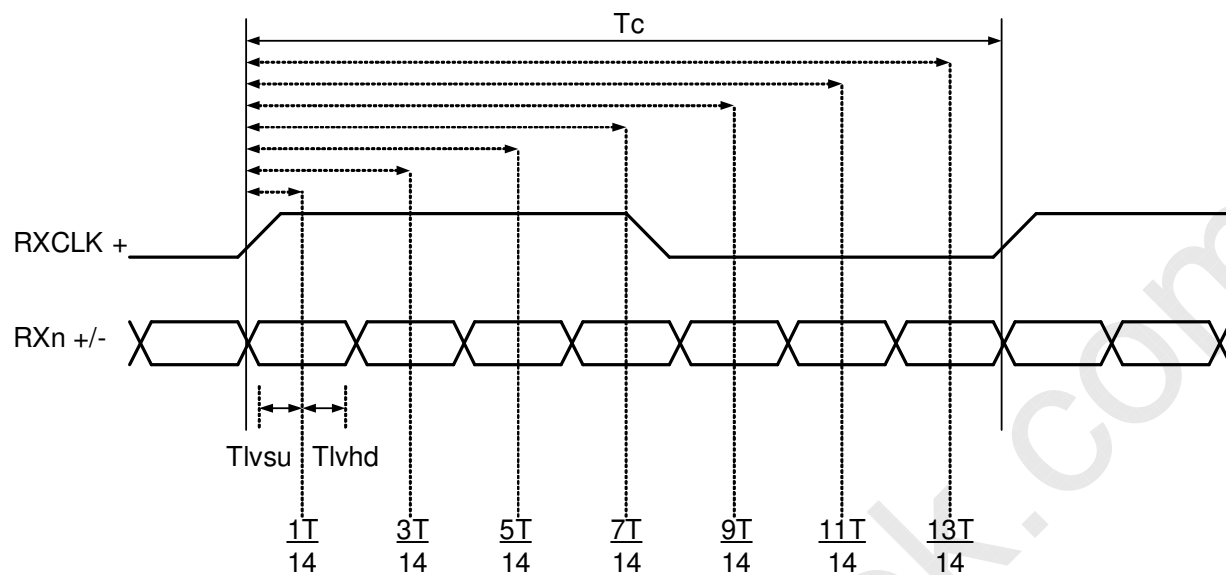
LVDS INPUT INTERFACE TIMING DIAGRAM

6.2 POWER ON/OFF SEQUENCE

($T_a = 25 \pm 2 \text{ }^\circ\text{C}$)

To prevent a latch-up or DC operation of LCD module, the power on/off sequence should follow the diagram below.

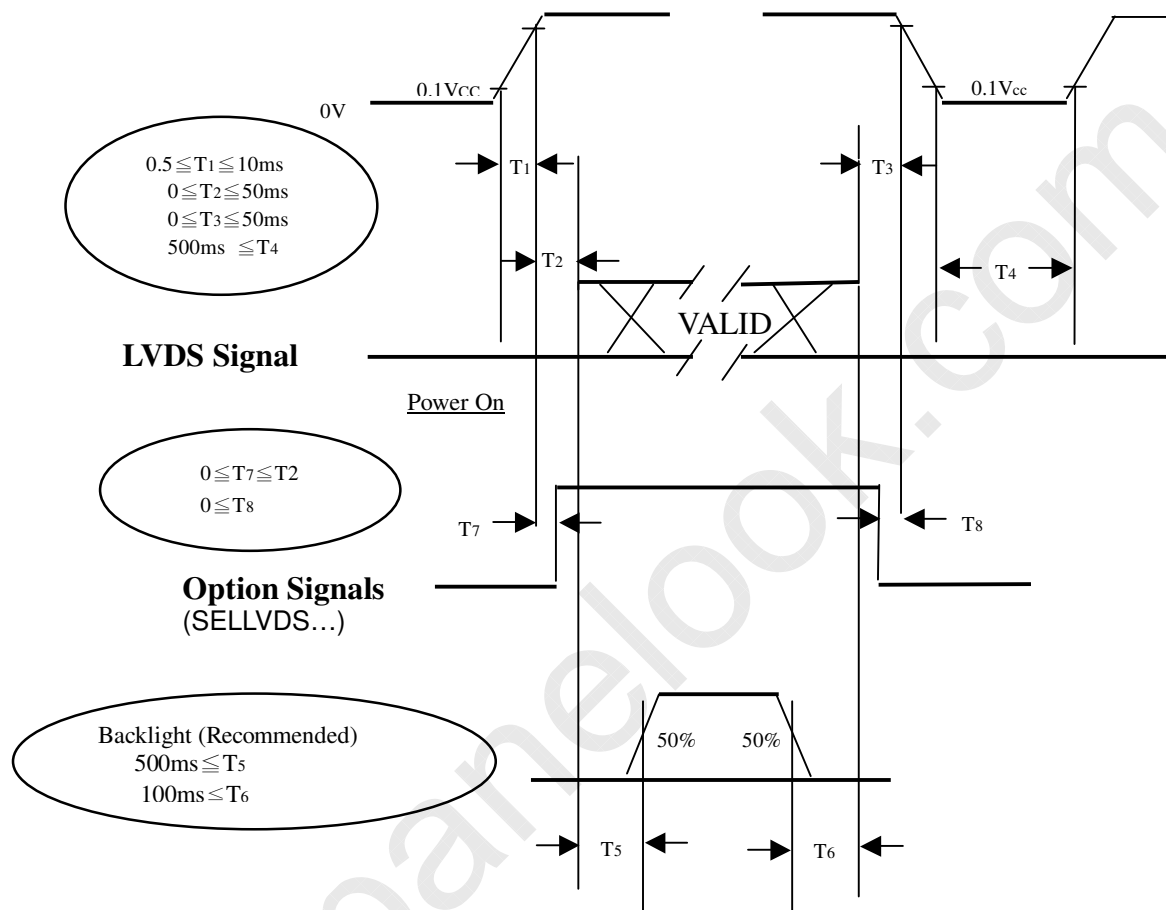

Power ON/OFF Sequence

Note.

- (1) The supply voltage of the external system for the module input should follow the definition of V_{CC}.
- (2) Apply the lamp voltage within the LCD operation range. When the backlight turns on before the LCD operation or the LCD turns off before the backlight turns off, the display may momentarily become abnormal screen.
- (3) In case of V_{CC} is in off level, please keep the level of input signals on the low or high impedance. If $T_2 < 0$, that maybe cause electrical overstress failures.
- (4) T₄ should be measured after the module has been fully discharged between power off and on period. Interface signal shall not be kept at high impedance when the power is on.

7. OPTICAL CHARACTERISTICS

7.1 TEST CONDITIONS

Item	Symbol	Value	Unit
Ambient Temperature	Ta	25±2	°C
Ambient Humidity	Ha	50±10	%RH
Supply Voltage	V _{CC}	12	V
Input Signal	According to typical value in "3. ELECTRICAL CHARACTERISTICS"		
Lamp Current(HV)	I _L	12.0 ± 0.5	mA
Oscillating Frequency (Balance Board)	F _w	63±3	KHz
Frame rate		120	Hz

7.2 OPTICAL SPECIFICATIONS

The relative measurement methods of optical characteristics are shown in 7.2. The following items should be measured under the test conditions described in 7.1 and stable environment shown in Note (6).

Item		Symbol	Condition	Min.	Typ.	Max.	Unit	Note	
Contrast Ratio		CR	$\theta_x=0^\circ, \theta_y=0^\circ$ Viewing angle at Normal direction	4000	5000	-	-	(2)	
Response Time		Gray to gray average		-	(4)	(8)	ms	(3)	
Center Luminance of White		L _C		(TBD)	450	-	cd/	(4)	
White Variation		δW		-	-	1.3	-	(7)	
Cross Talk		CT		-	-	4.0	%	(5)	
Color Chromaticity	Red	R _x		Viewing angle at Normal direction	Typ. - 0.03	(TBD)	Typ. + 0.03	-	(6)
		R _y				(TBD)		-	
	Green	G _x				(TBD)		-	
		G _y				(TBD)		-	
	Blue	B _x				(TBD)		-	
		B _y	(TBD)			-			
	White	W _x	0.280			-			
W _y		0.290	-						
Color Gamut		CG	70	72		%	NTSC		
Viewing Angle	Horizontal	θ_{x+}	CR≥20	80	88	-	Deg	(1)	
		θ_{x-}		80	88	-			
	Vertical	θ_{y+}		80	88	-			
		θ_{y-}		80	88	-			

Note (1) Definition of Viewing Angle (θ_x, θ_y):

Viewing angles are measured by EZ-Contrast 160R (Eldim)

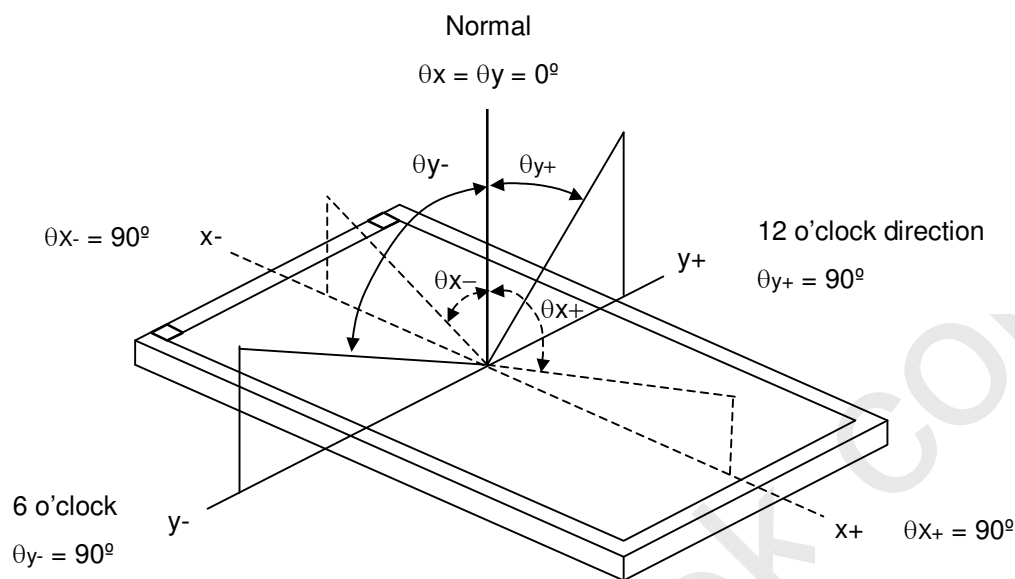

Note (2) Definition of Contrast Ratio (CR):

The contrast ratio can be calculated by the following expression.

$$\text{Contrast Ratio (CR)} = L_{255} / L_0$$

L255: Luminance of gray level 255

L 0: Luminance of gray level 0

CR = CR (5), where CR (X) is corresponding to the Contrast Ratio of the point X at the figure in Note (7).

Note (3) Definition of Gray to Gray Switching Time :

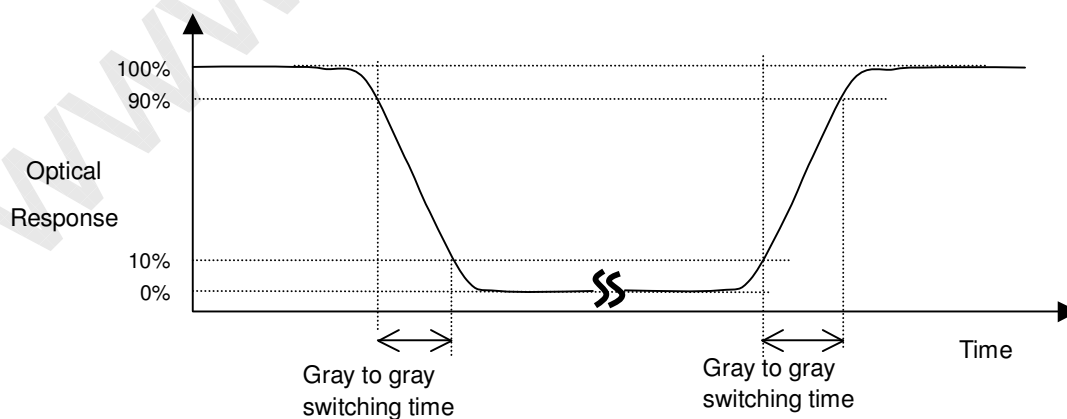

The driving signal means the signal of gray level 0, 63, 127, 191, 255.

Gray to gray average time means the average switching time of gray level 0, 63, 127, 191, 255 to each other.

Note (4) Definition of Luminance of White (L_C , L_{AVE}):

Measure the luminance of gray level 255 at center point and 5 points

$$L_C = L(5)$$

$$L_{AVE} = [L(1) + L(2) + L(3) + L(4) + L(5)] / 5$$

where $L(x)$ is corresponding to the luminance of the point X at the figure in Note (7).

Note (5) Definition of Cross Talk (CT):

$$CT = |Y_B - Y_A| / Y_A \times 100 (\%)$$

Where:

(a)

Y_A = Luminance of measured location without gray level 255 pattern (cd/m^2)

Y_B = Luminance of measured location with gray level 255 pattern (cd/m^2)

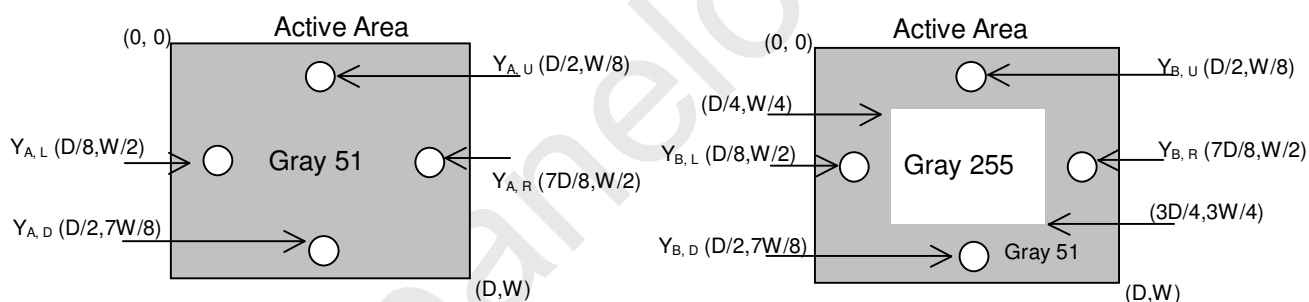

(b)

Y_A = Luminance of measured location without gray level 255 pattern (cd/m^2)

Y_B = Luminance of measured location with gray level 255 pattern (cd/m^2)

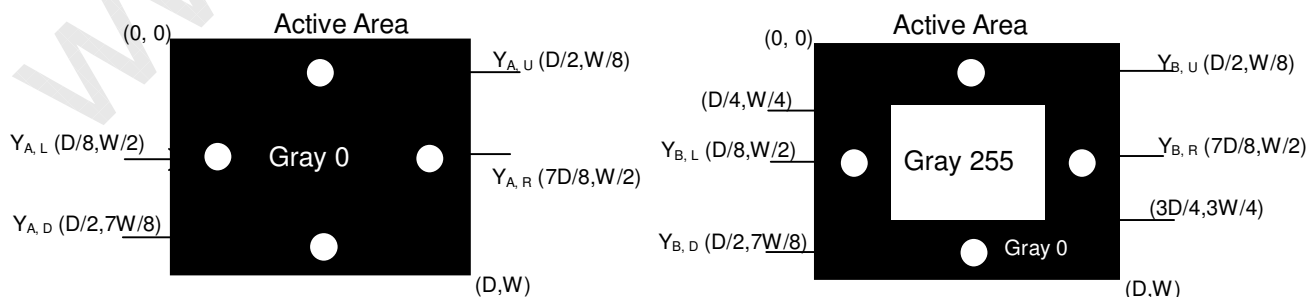

Note (6) Measurement Setup:

The LCD module should be stabilized at given temperature for 1 hour to avoid abrupt temperature change during measuring. In order to stabilize the luminance, the measurement should be executed after lighting Backlight for 1 hour in a windless room.

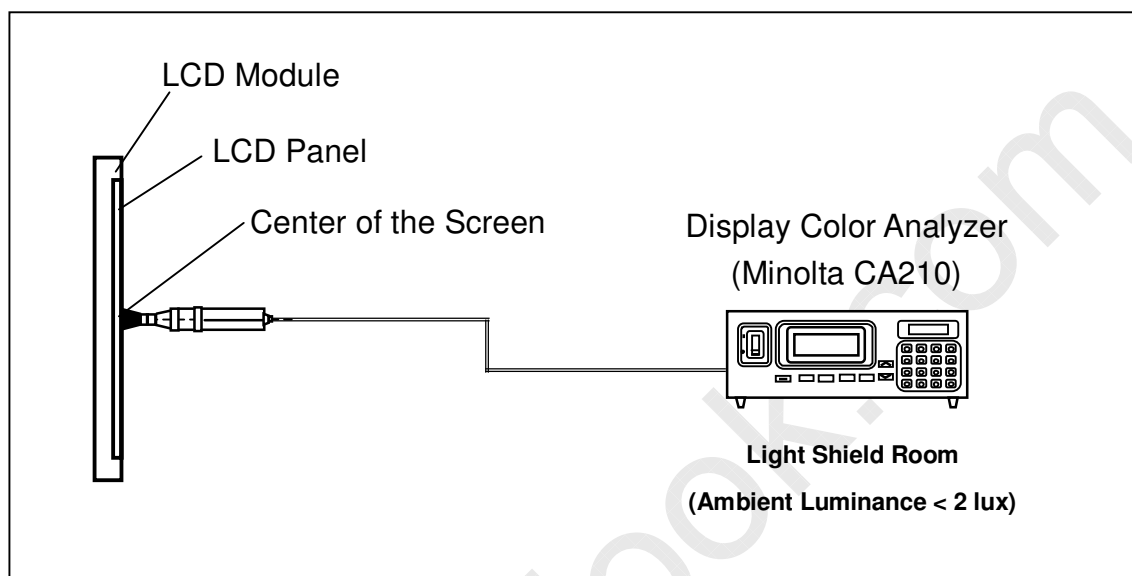
Note (7) Definition of White Variation (δW):

Measure the luminance of gray level 255 at 5 points

$$\delta W = \text{Maximum} [L(1), L(2), L(3), L(4), L(5)] / \text{Minimum} [L(1), L(2), L(3), L(4), L(5)]$$

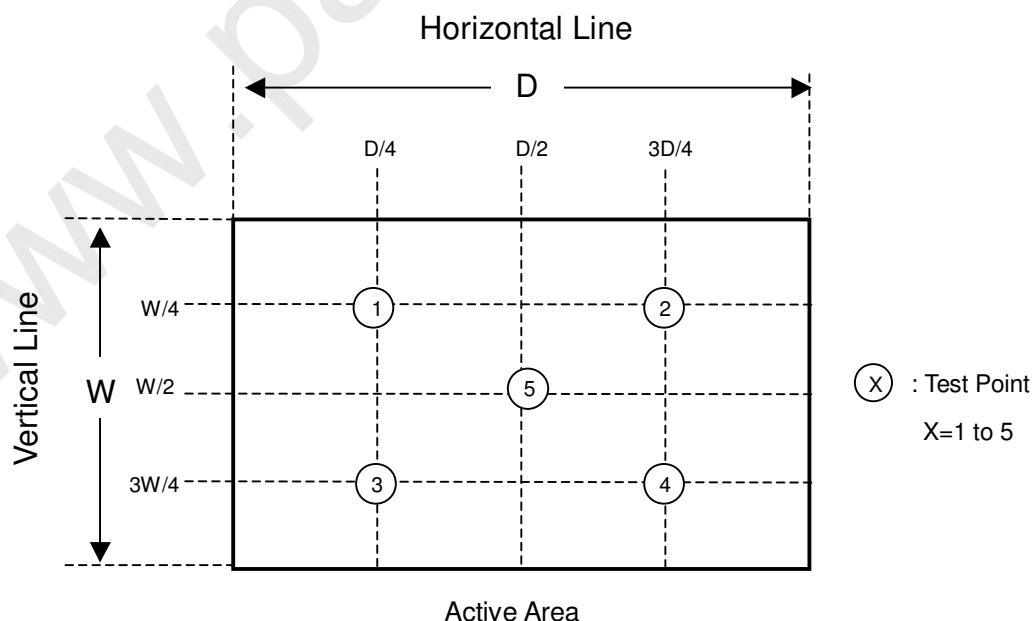

8. DEFINITION OF LABELS

8.1 CMO MODULE LABEL

The barcode nameplate is pasted on each module as illustration, and its definitions are as following explanation.

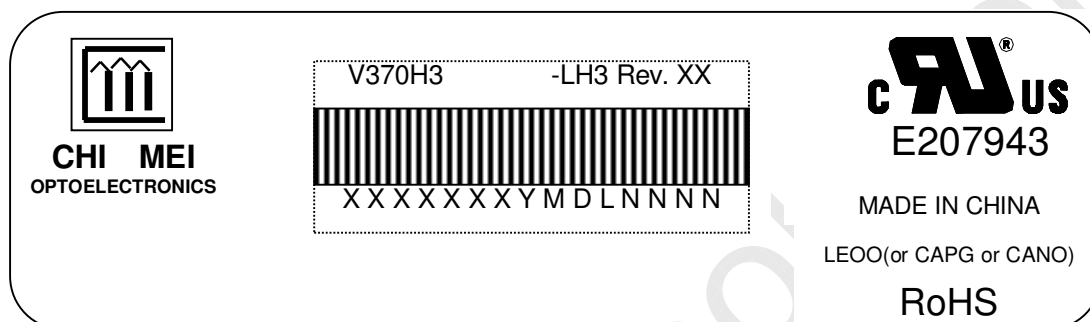
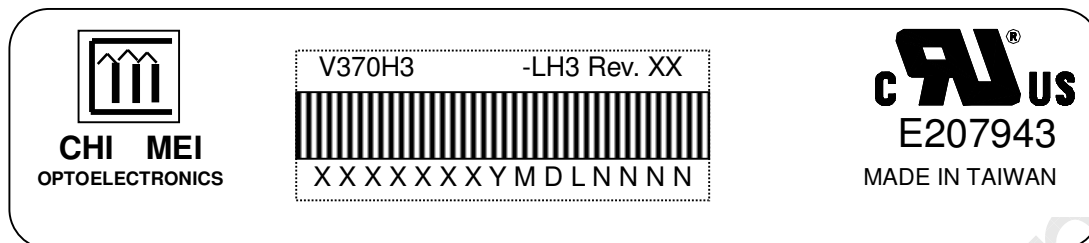

- (a) Model Name: V370H3-LH3
 (b) Revision: Rev. XX, for example: A0, A1... B1, B2... or C1, C2...etc.
 (c) CMO barcode definition:

Serial ID: XX-XX-X-XX-YMD-L-NNNN

Code	Meaning	Description
XX	CMO internal use	-
XX	Revision	Cover all the change
X-XX	CMO internal use	-
YMD	Year, month, day	Year: 2001=1, 2002=2, 2003=3, 2004=4... Month: Jan. ~ Dec.=1, 2, 3, ~, 9, A, B, C Day: 1 st to 31 st =1, 2, 3, ~, 9, A, B, C, ~, W, X, Y, exclude I, O, and U
L	Product line #	Line 1=1, Line 2=2, Line 3=3, ...
NNNN	Serial number	Manufacturing sequence of product

9. PACKAGING

9.1 PACKING SPECIFICATIONS

- (1) 5 LCD TV modules / 1 Box
- (2) Box dimensions : 954(L)x378(W)x602(H)mm
- (3) Weight : approximately 42.5 Kg (5 modules per box)

9.2 PACKING METHOD

Figures 10-1 and 10-2 are the packing method

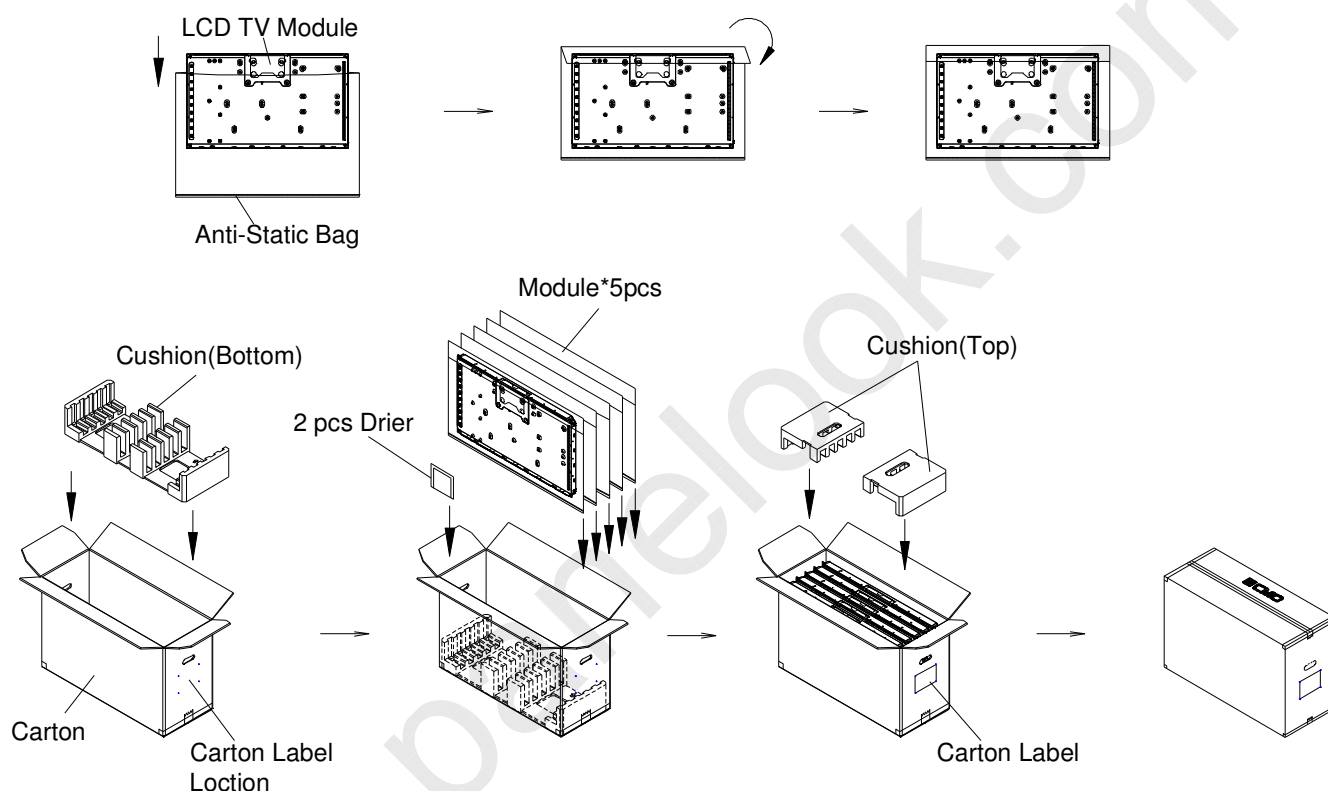
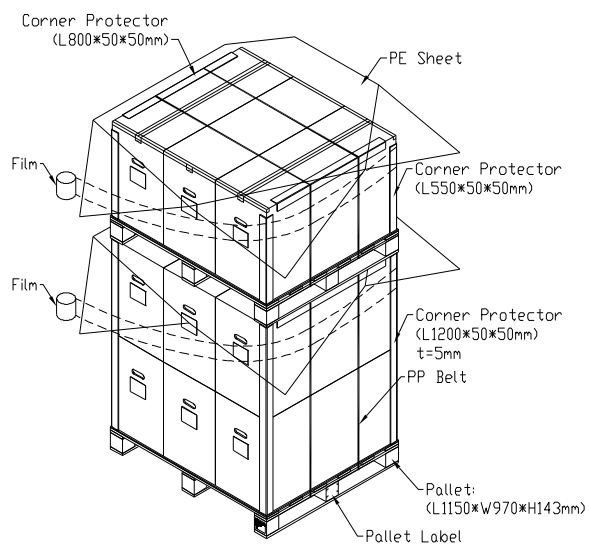

Figure.9-1 packing method

Sea / Land Transportation (40ft Container)



Air Transportation

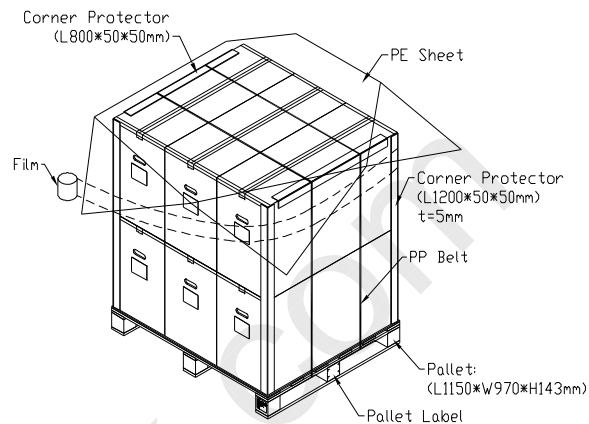

Figure.9-2 Packing method

10. PRECAUTIONS

10.1 ASSEMBLY AND HANDLING PRECAUTIONS

- (1) Do not apply rough force such as bending or twisting to the module during assembly.
- (2) It is recommended to assemble or to install a module into the user's system in clean working areas.
The dust and oil may cause electrical short or worsen the polarizer.
- (3) Do not apply pressure or impulse to the module to prevent the damage of LCD panel and backlight.
- (4) Always follow the correct power-on sequence when the LCD module is turned on. This can prevent the damage and latch-up of the CMOS LSI chips.
- (5) Do not plug in or pull out the I/F connector while the module is in operation.
- (6) Do not disassemble the module.
- (7) Use a soft dry cloth without chemicals for cleaning, because the surface of polarizer is very soft and easily scratched.
- (8) Moisture can easily penetrate into LCD module and may cause the damage during operation.
- (9) High temperature or humidity may deteriorate the performance of LCD module. Please store LCD modules in the specified storage conditions.
- (10) When ambient temperature is lower than 10°C, the display quality might be reduced. For example, the response time will become slow, and the starting voltage of CCFL will be higher than that of room temperature.

10.2 SAFETY PRECAUTIONS

- (1) The startup voltage of a backlight is over 1000 Volts. It may cause an electrical shock while assembling with the inverter. Do not disassemble the module or insert anything into the backlight unit.
- (2) If the liquid crystal material leaks from the panel, it should be kept away from the eyes or mouth. In case of contact with hands, skin or clothes, it has to be washed away thoroughly with soap.
- (3) After the module's end of life, it is not harmful in case of normal operation and storage.

10.3 SAFETY STANDARDS

The LCD module should be certified with safety regulations as follows:

- (1) UL60950-1 or updated standard.
- (2) IEC60950-1 or updated standard.
- (3) UL60065 or updated standard.
- (4) IEC60065 or updated standard.

11. MECHANICAL CHARACTERISTICS

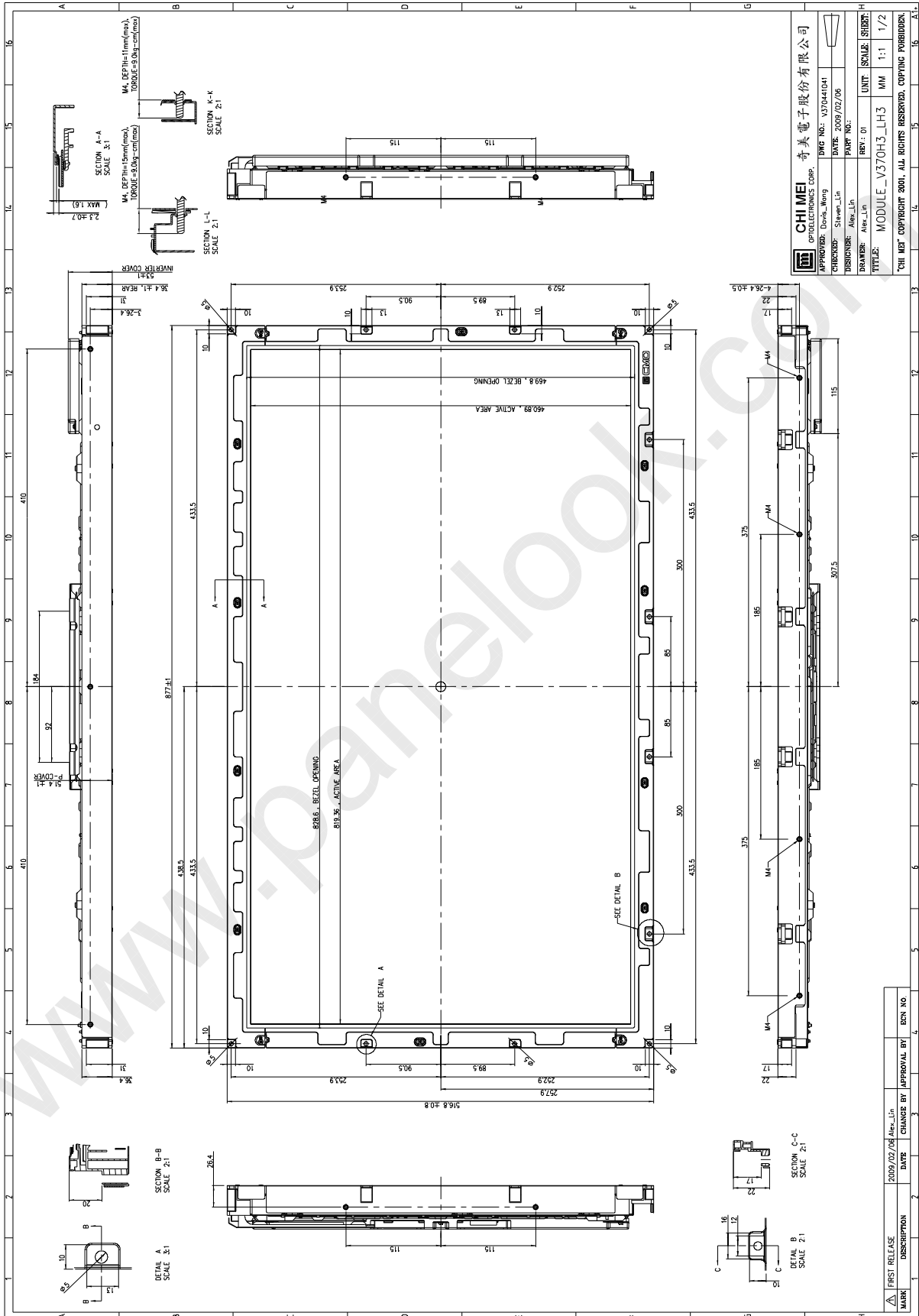

CHI MEI OPTOELECTRONICS CORP.		奇美電子股份有限公司	
APPROVER: Davis, Wang	DATE: 2009/02/05	DWG NO.: V370H41041	UNIT: SCALE: SUBST:
CHECKER: Steven Lin	DATE: 2009/02/05	PAPP NO.:	MM 1:1 1/2
DISPOSER: Alex Lin	DATE: 2009/02/05	REV: 01	MM 1:1 1/2
DRAWER: Alex Lin	DATE: 2009/02/05	TITLE: MODULE_V370H3-LH3	
CHI MEI COPYRIGHT 2001. ALL RIGHTS RESERVED. COPYING PROHIBITED.			

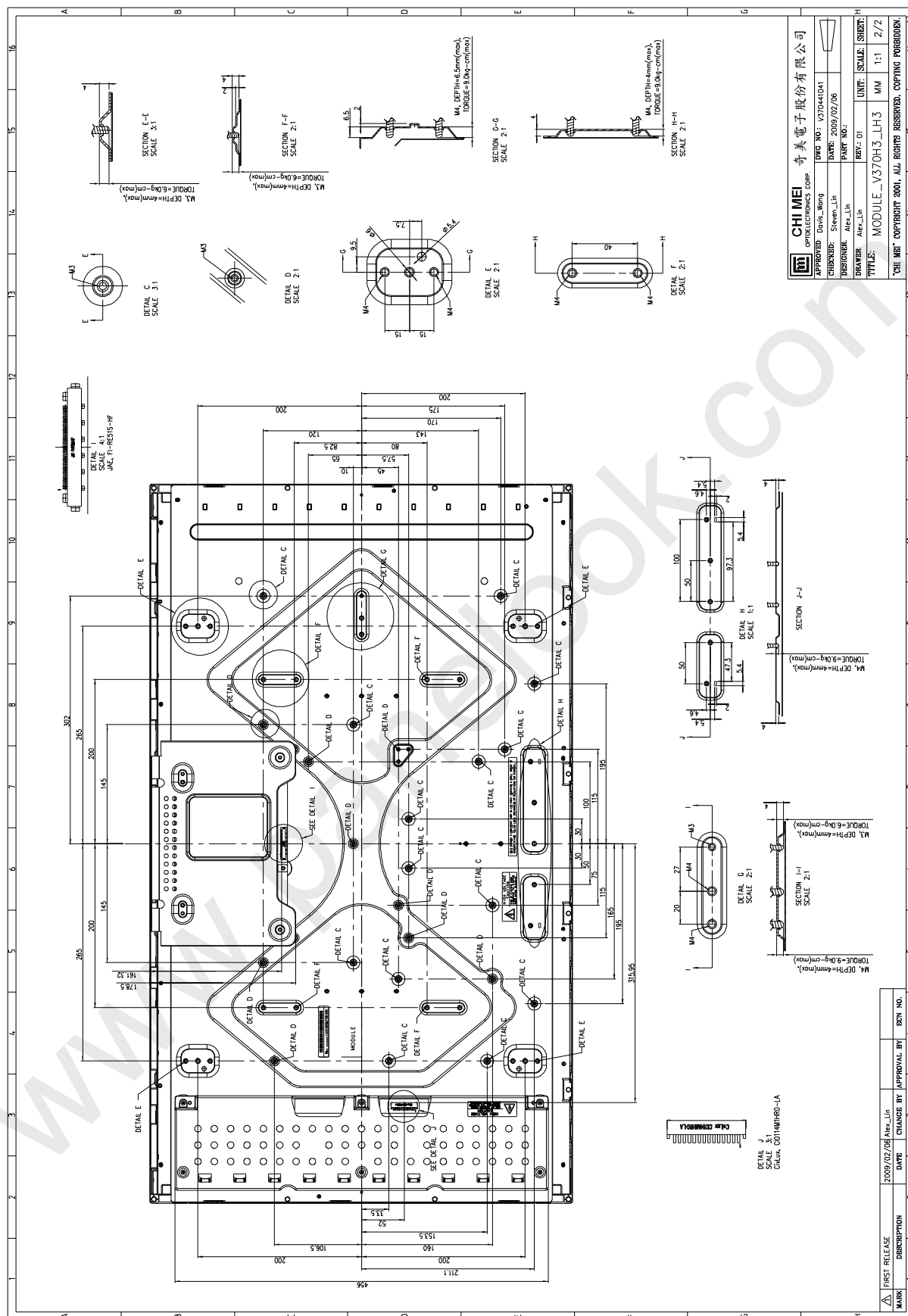

CHI MEI Optoelectronics Corp.		奇美電子股份有限公司	
UPPER/REV: Dava_Wing	DWG. NO.: V370441041	DATE: 2009/02/26	
DESIGNER: Steven_Lin	PART NO.:	REV: 01	
DRAWER: Alex_Lin	UNIT: MM	SCALE: 1:1	SHEET: 2/2
TITLE: MODULE_V370H3_LH3			
CHI MEI COPYRIGHT 2001. ALL RIGHTS RESERVED. COPYING FORBIDDEN.			

MARK	FIRST RELEASE	DATE	CHANGE BY	APPROVAL BY	REV. NO.
△	DISCREPTION	2009/02/26	Alex_Lin		1