

- Tentative Specification
- Preliminary Specification
- Approval Specification

MODEL NO.: V390HJ1
SUFFIX: LE1

Customer:	
APPROVED BY	SIGNATURE
Name / Title _____	_____
Note	
<hr/> Please return 1 copy for your confirmation with your signature and comments.	

Approved By	Checked By	Prepared By
Chao-Chun Chung	Roger Huang	WJ Chang

CONTENTS

1. GENERAL DESCRIPTION	5
1.1 OVERVIEW	5
1.2 FEATURES	5
1.3 APPLICATION	5
1.4 GENERAL SPECIFICATIONS	5
1.5 MECHANICAL SPECIFICATIONS	6
2. ABSOLUTE MAXIMUM RATINGS	7
2.1 ABSOLUTE RATINGS OF ENVIRONMENT	7
2.2 PACKAGE STORAGE	8
2.3 ELECTRICAL ABSOLUTE RATINGS	8
2.3.1 TFT LCD MODULE	8
2.3.2 BACKLIGHT CONVERTER UNIT	8
3. ELECTRICAL CHARACTERISTICS	9
3.1 TFT LCD MODULE (Ta = 25 ± 2 °C)	9
3.2 BACKLIGHT CONVERTER UNIT	12
3.2.1 LED LIGHT BAR CHARACTERISTICS (Ta = 25 ± 2 °C)	12
3.2.2 CONVERTER CHARACTERISTICS (Ta = 25 ± 2 °C)	12
3.2.3 CONVERTER INTERFACE CHARACTERISTICS	13
4. BLOCK DIAGRAM OF INTERFACE	14
4.1 TFT LCD MODULE	15
5. INTERFACE PIN CONNECTION	16
5.1 TFT LCD MODULE	16
5.2 BACKLIGHT UNIT	19
5.3 CONVERTER UNIT	19
5.4 BLOCK DIAGRAM OF INTERFACE	21
5.5 LVDS INTERFACE	23
5.6 COLOR DATA INPUT ASSIGNMENT	24
6. INTERFACE TIMING	25
6.1 INPUT SIGNAL TIMING SPECIFICATIONS (Ta = 25 ± 2 °C)	25
6.2 POWER ON/OFF SEQUENCE	28
7. OPTICAL CHARACTERISTICS	29

7.1 TEST CONDITIONS	29
7.2 OPTICAL SPECIFICATIONS.....	30
8. PRECAUTIONS.....	30
8.1 ASSEMBLY AND HANDLING PRECAUTIONS.....	33
8.2 SAFETY PRECAUTIONS.....	33
9. DEFINITION OF LABELS.....	34
9.1 CMI MODULE LABEL.....	34
10. PACKAGING.....	35
10.1 PACKAGING SPECIFICATIONS.....	35
10.2 PACKAGING METHOD	35
11. MECHANICAL CHARACTERISTIC.....	37

REVISION HISTORY

Version	Date	Page(New)	Section	Description
Ver. 2.0	March 12, 2012	All	All	Approval Specification was first issued.

1. GENERAL DESCRIPTION

1.1 OVERVIEW

V390HJ1-LE1 is a 39" TFT Liquid Crystal Display module with LED Backlight unit and 2ch-LVDS interface. This module supports 1920 x 1080 Full HDTV format and can display 16.7M colors (8-bit). The converter module for backlight is built-in.

1.2 FEATURES

- High brightness (300 nits)
- High contrast ratio (3500:1)
- Fast response time (Gray to gray average 9.5 ms)
- High color saturation (NTSC 68%)
- Full HDTV (1920 x 1080 pixels) resolution, true HDTV format
- LVDS (Low Voltage Differential Signaling) interface
- Ultra wide viewing angle : Super MVA technology
- Viewing Angle : 176(H)/176(V) (CR ≥ 20) VA Technology
- RoHs compliance

1.3 APPLICATION

- Standard Living Room TVs
- Public Display Application
- Home Theater Application
- MFM Application

1.4 GENERAL SPECIFICATIONS

Item	Specification	Unit	Note
Active Area	853.92 (H) x480.33 (V)	mm	(1)
Bezel Opening Area	858.92 (H) x485.33 (V)	mm	
Driver Element	a-si TFT active matrix	-	-
Pixel Number	1920 x R.G.B. x 1080	pixel	-
Pixel Pitch(Sub Pixel)	0.14825 (H) x 0.44475 (V)	mm	-
Pixel Arrangement	RGB vertical stripe	-	-
Power consumption	55.2W	Watt	(2)
Display Colors	16.7M	color	-
Display Operation Mode	Transmissive mode / Normally Black	-	-
Surface Treatment	Anti-Glare coating (Haze 3.5%) Hard Coating (3H)	-	(3)

Note (1) Please refer to the attached drawings in chapter 9 for more information about the front and back outlines.

Note (2) Please refer sec 3.1 and 3.2 for more information of Power consumption

Note (3) The spec. of the surface treatment is temporarily for this phase. CMI reserves the rights to change this feature.

1.5 MECHANICAL SPECIFICATIONS

Item		Min.	Typ.	Max.	Unit	Note
Module Size	Horizontal (H)	877.72	878.72	879.72	mm	(1)
	Vertical (V)	509.23	510.23	511.23	mm	(1)
	Depth (D)	21.3	22.3	23.3	mm	(2)
	Depth (D)	26.4	27.4	28.4	mm	(3)
Weight		7,110	7,470	7,710	g	-

Note (1) Please refer to the attached drawings for more information of front and back outline dimensions.

Note (2) Module Depth is between bezel to T-CON cover.

Note (3) Module Depth is between bezel to Converter cover

2. ABSOLUTE MAXIMUM RATINGS

2.1 ABSOLUTE RATINGS OF ENVIRONMENT

Item	Symbol	Value		Unit	Note
		Min.	Max.		
Storage Temperature	TST	-20	+60	°C	(1)
Operating Ambient Temperature	TOP	0	50	°C	(1), (2)
Shock (Non-Operating)	SNOP	-	50	G	(3), (5)
Vibration (Non-Operating)	VNOP	-	1.0	G	(4), (5)

Note (1) Temperature and relative humidity range is shown in the figure below.

(a) 90 %RH Max. ($T_a \leq 40$ °C).

(b) Wet-bulb temperature should be 39 °C Max. ($T_a > 40$ °C).

(c) No condensation.

Note (2) The maximum operating temperature is based on the test condition that the surface temperature of display area is less than or equal to 65 °C with LCD module alone in a temperature controlled chamber. Thermal management should be considered in final product design to prevent the surface temperature of display area from being over 65 °C. The range of operating temperature may degrade in case of improper thermal management in final product design.

Note (3) 11 ms, half sine wave, 1 time for $\pm X$, $\pm Y$, $\pm Z$.

Note (4) 10 ~ 200 Hz, 10 min, 1 time each X, Y, Z.

Note (5) At testing Vibration and Shock, the fixture in holding the module has to be hard and rigid enough so that the module would not be twisted or bent by the fixture.

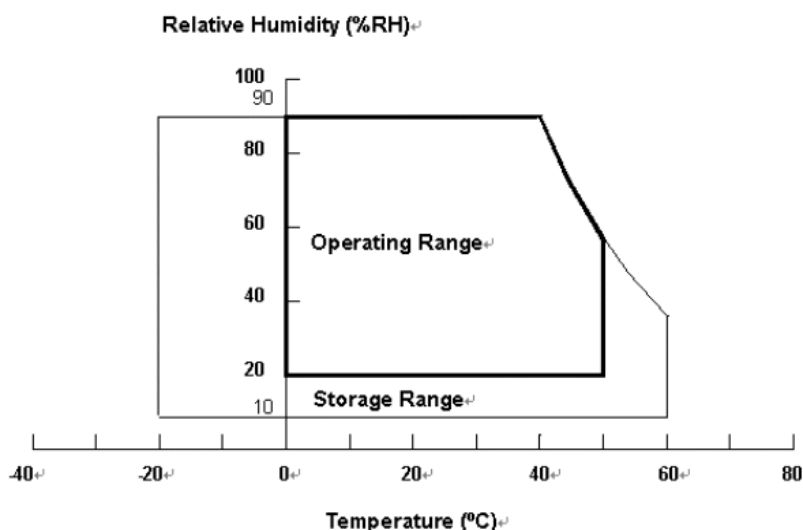

2.2 PACKAGE STORAGE

When storing modules as spares for a long time, the following precaution is necessary.

- (a) Do not leave the module in high temperature, and high humidity for a long time, It is highly recommended to store the module with temperature from 0 to 35 °C at normal humidity without condensation.
- (b) The module shall be stored in dark place. Do not store the TFT-LCD module in direct sunlight or fluorescent light.

2.3 ELECTRICAL ABSOLUTE RATINGS

2.3.1 TFT LCD MODULE

Item	Symbol	Value		Unit	Note
		Min.	Max.		
Power Supply Voltage	VCC	-0.3	13.5	V	(1)
Logic Input Voltage	VIN	-0.3	3.6	V	

2.3.2 BACKLIGHT CONVERTER UNIT

Item	Symbol	Value		Unit	Note
		Min.	Max.		
Light Bar Voltage	VW	—	60	VRMS	
Converter Input Voltage	VBL	0	30	V	(1)
Control Signal Level	—	-0.3	7	V	(1), (3)

Note (1) Permanent damage to the device may occur if maximum values are exceeded. Functional operation should be restricted to the conditions described under normal operating conditions.

Note (2) No moisture condensation or freezing.

Note (3) The control signals include On/Off Control and External PWM Control.

3. ELECTRICAL CHARACTERISTICS

3.1 TFT LCD MODULE

(Ta = 25 ± 2 °C)

Parameter		Symbol	Value			Unit	Note
			Min.	Typ.	Max.		
Power Supply Voltage		V _{CC}	10.8	12	13.2	V	(1)
Rush Current		I _{RUSH}	—	—	2.64	A	(2)
Power Consumption	White Pattern	—	—	4.32	5.68	W	(3)
	Horizontal Stripe	—	—	6.96	9.11	W	
	Black Pattern	—	—	4.2	5.54	W	
Power Supply Current	White Pattern	—	—	0.36	0.43	A	
	Horizontal Stripe	—	—	0.58	0.69	A	
	Black Pattern	—	—	0.35	0.42	A	
LVDS interface	Differential Input High Threshold Voltage	V _{LVTH}	+100	—	—	mV	(4)
	Differential Input Low Threshold Voltage	V _{LVTL}	—	—	-100	mV	
	Common Input Voltage	V _{CM}	1.0	1.2	1.4	V	
	Differential input voltage (single-end)	V _{ID}	200	—	600	mV	
	Terminating Resistor	R _T	—	100	—	ohm	
CMIS interface	Input High Threshold Voltage	V _{IH}	2.7	—	3.3	V	
	Input Low Threshold Voltage	V _{IL}	0	—	0.7	V	

Note (1) The module should be always operated within the above ranges.

Note (2) Measurement Conditions:

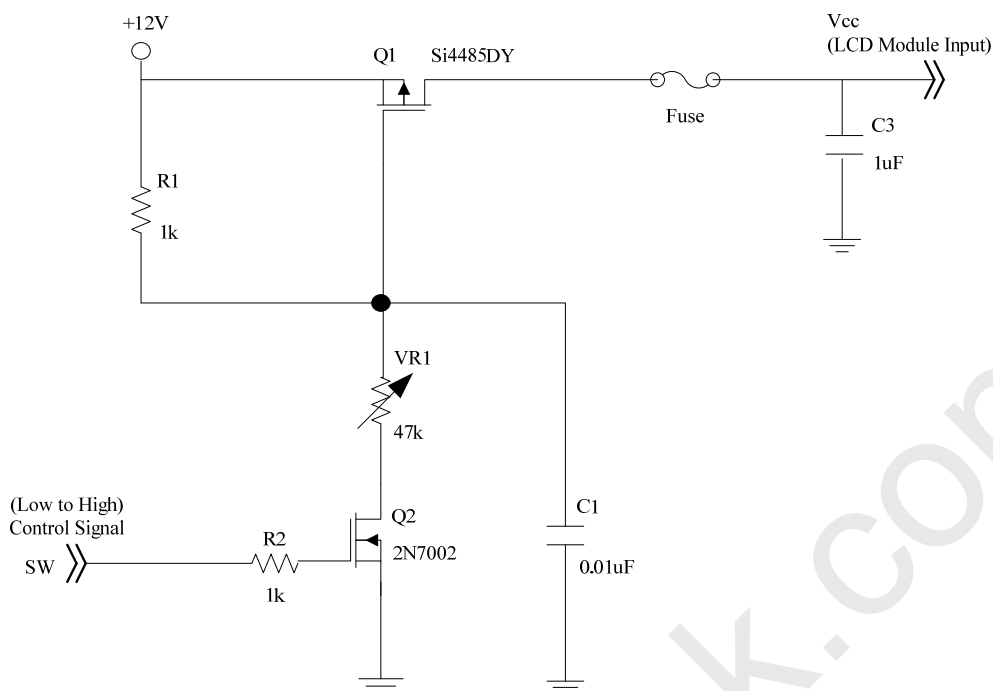

Vcc rising time is 470us

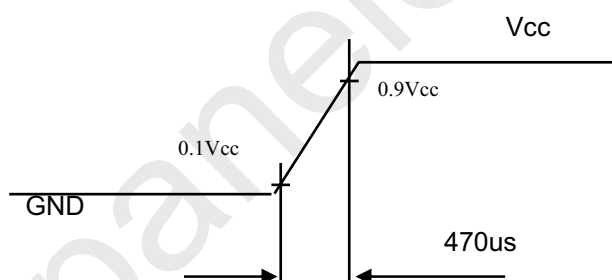

Note (3) The specified power supply current is under the conditions at $V_{cc} = 12\text{ V}$, $T_a = 25 \pm 2\text{ }^\circ\text{C}$, $f_v = 60\text{ Hz}$, whereas a power dissipation check pattern below is displayed.

a. White Pattern



Active Area

b. Black Pattern

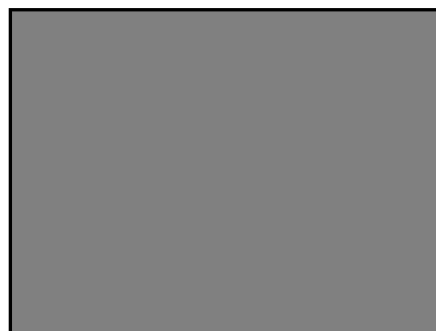

Active Area

c. Horizontal Stripe Pattern

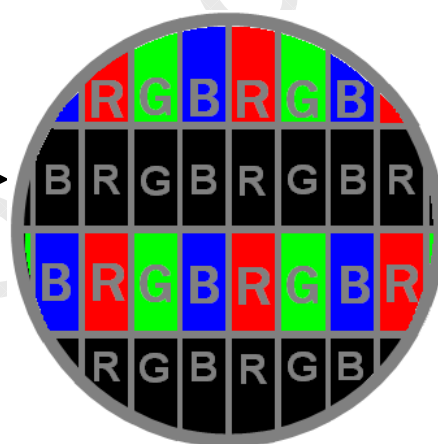
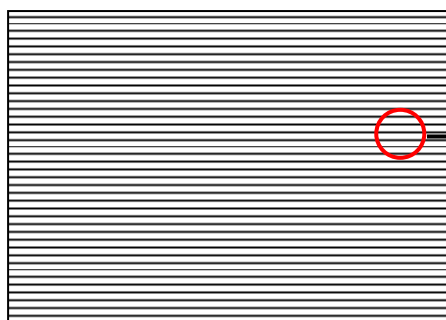

Note (4) The LVDS input characteristics are as follows:

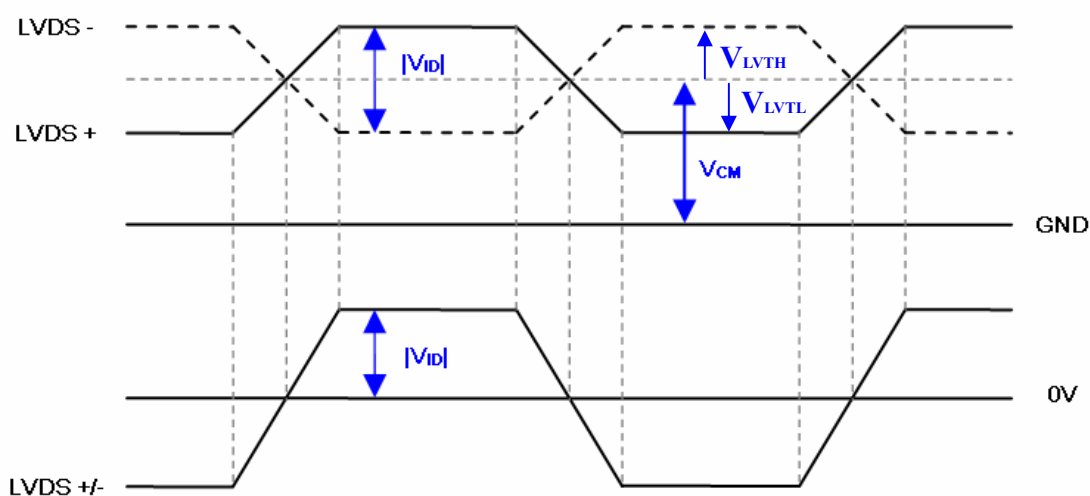

3.2 BACKLIGHT CONVERTER UNIT

3.2.1 LED LIGHT BAR CHARACTERISTICS (Ta = 25 ± 2 °C)

The backlight unit contains 1 pc light bar.

Parameter	Symbol	Value			Unit	Note
		Min.	Typ.	Max.		
Total Current (1 String)	I _L	136.3	145.0	153.7	mA	
One String Voltage	V _W	-	-	39.6	V _{DC}	I _L = 145mA
One String Voltage Variation	ΔV _W	-	-	TBD	V	
Life time	-	30,000	-	-	Hrs	(1)

Note (1) The lifetime is defined as the time which luminance of the LED decays to 50% compared to the initial value, Operating condition: Continuous operating at Ta = 25±2°C, IL = 145mA

3.2.2 CONVERTER CHARACTERISTICS (Ta = 25 ± 2 °C)

Parameter	Symbol	Value			Unit	Note
		Min.	Typ.	Max.		
Power Consumption	P _{BL}	-	48.24	55.68	W	(1), (2) IL = 145 mA
Converter Input Voltage	V _{BL}	22.8	24.0	25.2	V _{DC}	
Converter Input Current	I _{BL}	-	2.01	2.32	A	Non Dimming
Input Inrush Current	I _R	-	-	3.12	A _{peak}	V _{BL} = 22.8V, (IL = typ.) (3), (5)
Dimming Frequency	FB	150	160	170	Hz	
Minimum Duty Ratio	DMIN	5	10	-	%	(4), (5)

Note (1) The power supply capacity should be higher than the total converter power consumption P_{BL}. Since the pulse width modulation (PWM) mode was applied for backlight dimming, the driving current changed as PWM duty on and off. The transient response of power supply should be considered for the changing loading when converter dimming.

Note (2) The measurement condition of Max. value is based on 39" backlight unit under input voltage 24V, average LED current 153.7 mA

Note (3) For input inrush current measure, the V_{BL} rising time from 10% to 90% is about 30ms.

Note (4) 5% minimum duty ratio is only valid for electrical operation.

3.2.3 CONVERTER INTERFACE CHARACTERISTICS

Parameter	Symbol	Test Condition	Value			Unit	Note		
			Min.	Typ.	Max.				
On/Off Control Voltage	ON	VBLON	—	2.0	—	5.0	V		
	OFF		—	0	—	0.8	V		
External PWM Control Voltage	HI	VEPWM	—	2.0	—	5.0	V	Duty on	(5)
	LO		—	0	—	0.8	V	Duty off	
Error Signal		ERR	—	—	—	—	Abnormal: Open collector Normal: GND (4)		
VBL Rising Time		Tr1	—	30	—	—	ms	10%-90%V _{BL}	
Control Signal Rising Time		Tr	—	—	—	100	ms		
Control Signal Falling Time		Tf	—	—	—	100	ms		
PWM Signal Rising Time		TPWMR	—	—	—	50	us		
PWM Signal Falling Time		TPWMF	—	—	—	50	us		
Input Impedance		Rin	—	1	—	—	MΩ		
PWM Delay Time		TPWM	—	100	—	—	ms		
BLON Delay Time		T _{on}	—	300	—	—	ms		
		T _{on1}	—	300	—	—	ms		
BLON Off Time		Toff	—	300	—	—	ms		

Note (1) The Dimming signal should be valid before backlight turns on by BLON signal. It is inhibited to change the external PWM signal during backlight turn on period.

Note (2) The power sequence and control signal timing are shown in the Fig.1. For a certain reason, the converter has a possibility to be damaged with wrong power sequence and control signal timing.

Note (3) While system is turned ON or OFF, the power sequences must follow as below descriptions:

Turn ON sequence: VBL → PWM signal → BLON

Turn OFF sequence: BLOFF → PWM signal → VBL

Note (4) When converter protective function is triggered, ERR will output open collector status. (Fig.2)

Note (5) The EPWM interface that inserts a pull up resistor to 5V in Max Duty (100%), please refers to Fig.3.

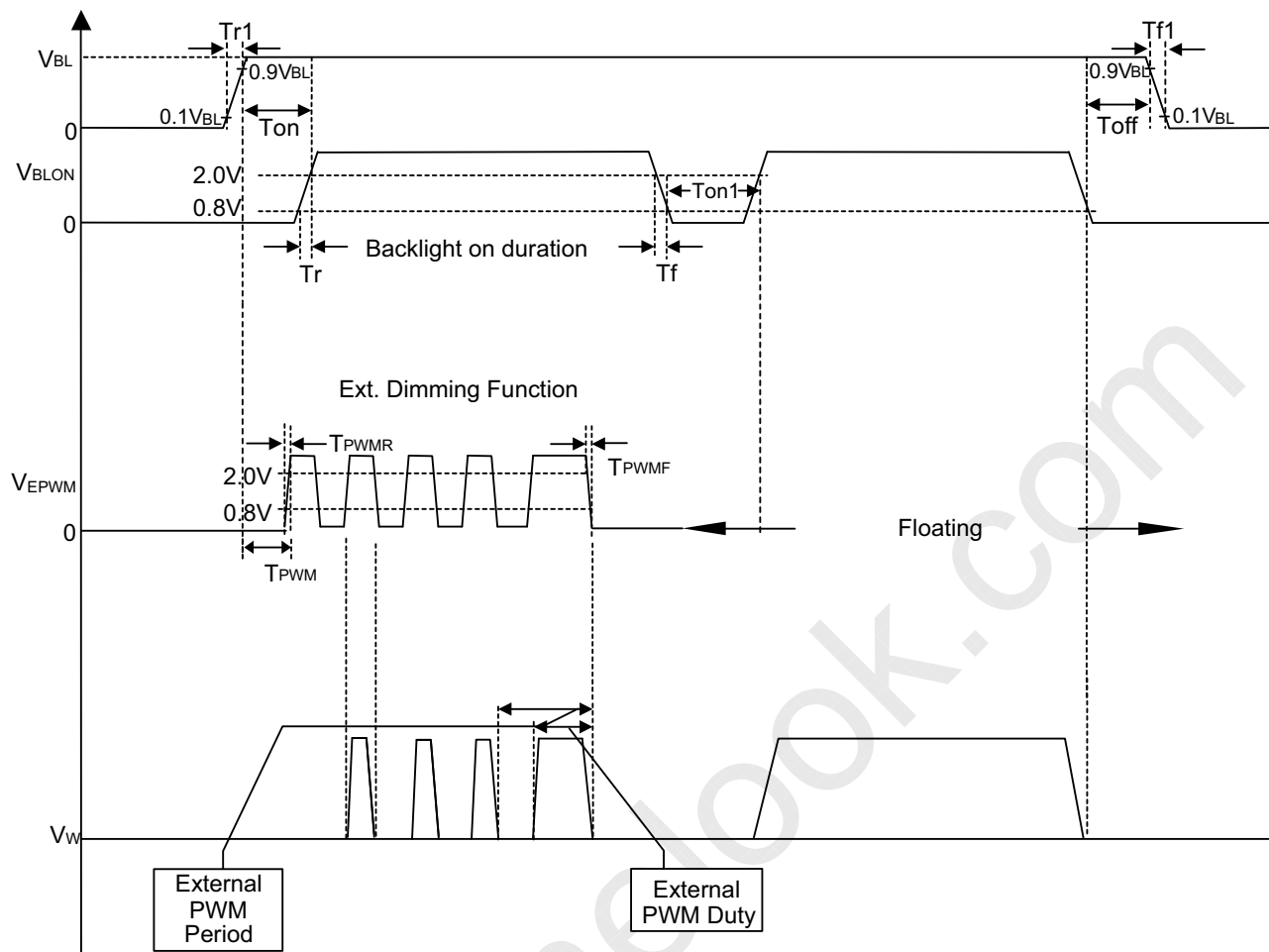

100%

Fig. 1

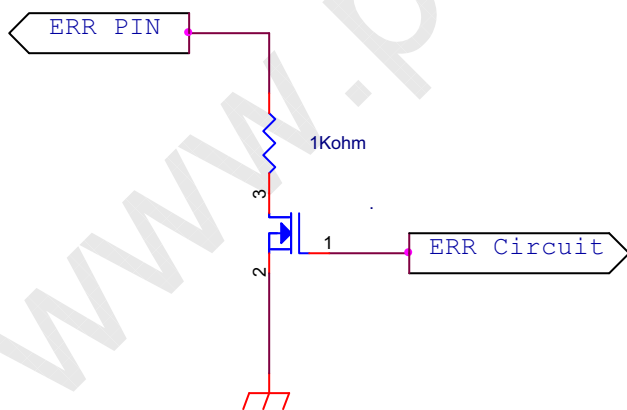

Fig. 2

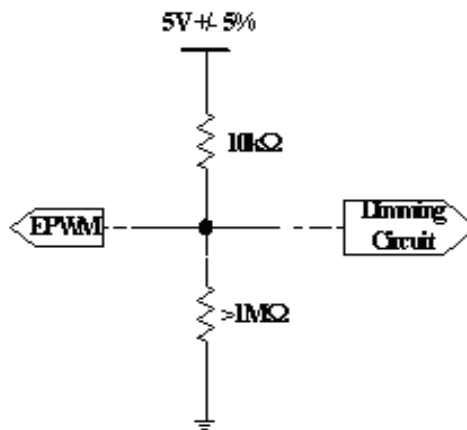
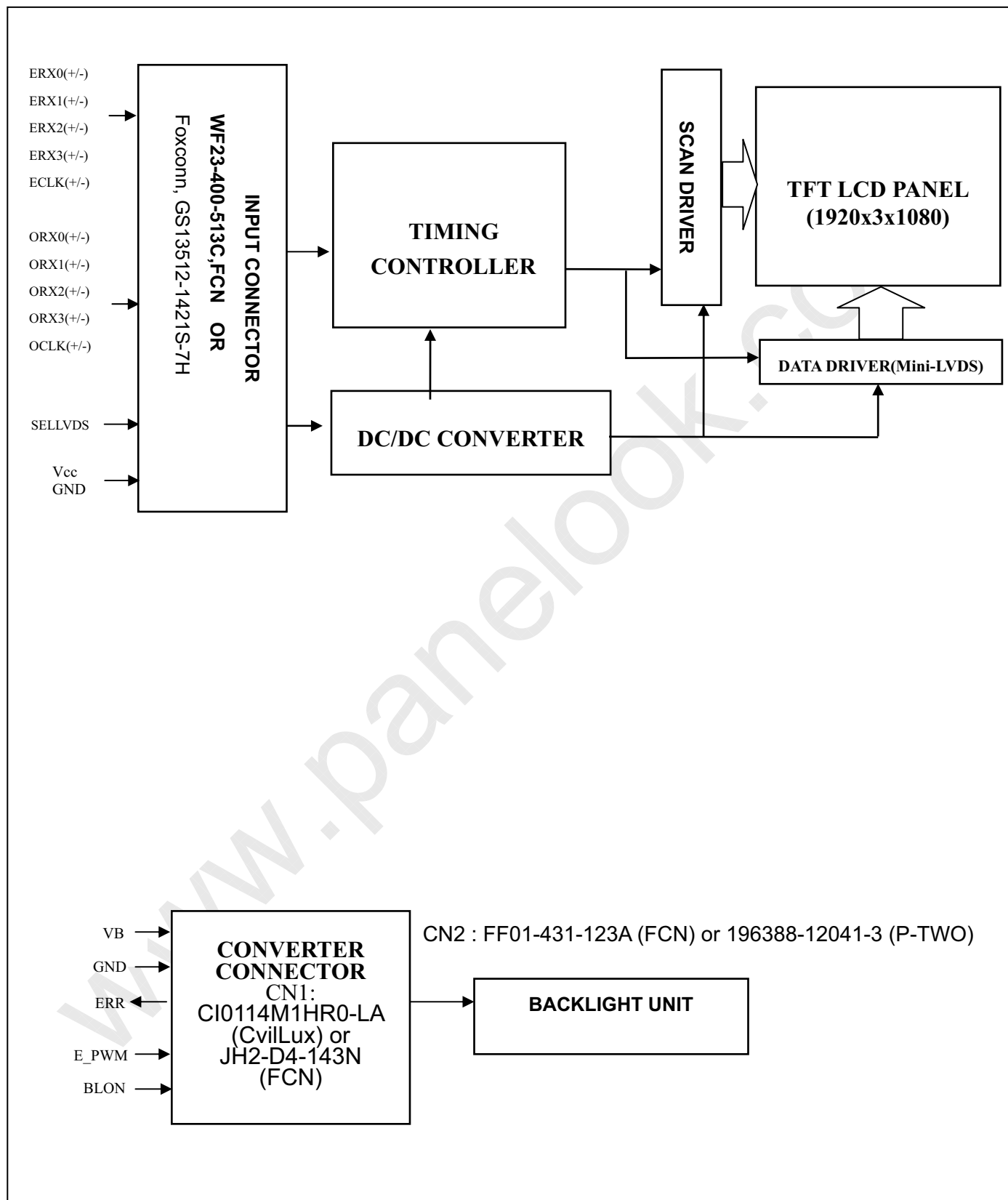

Fig. 3

4. BLOCK DIAGRAM OF INTERFACE
4.1 TFT LCD MODULE

5. INTERFACE PIN CONNECTION

5.1 TFT LCD MODULE

CNF1 Connector Part No.: WF23-400-513C,(FCN) or equivalent or Foxconn,GS13512-1421S-7H

Pin	Name	Description	Note
1	N.C.	No Connection	(2)
2	N.C.	No Connection	
3	N.C.	No Connection	
4	N.C.	No Connection	
5	N.C.	No Connection	
6	N.C.	No Connection	
7	SELLVDS	LVDS data format Selection	(3)(4)
8	N.C.	No Connection	(2)
9	N.C	No Connection	(2)
10	N.C.	No Connection	(2)
11	GND	Ground	
12	ORX0-	Odd pixel Negative LVDS differential data input. Channel 0	(5)
13	ORX0+	Odd pixel Positive LVDS differential data input. Channel 0	
14	ORX1-	Odd pixel Negative LVDS differential data input. Channel 1	
15	ORX1+	Odd pixel Positive LVDS differential data input. Channel 1	
16	ORX2-	Odd pixel Negative LVDS differential data input. Channel 2	
17	ORX2+	Odd pixel Positive LVDS differential data input. Channel 2	
18	GND	Ground	
19	OCLK-	Odd pixel Negative LVDS differential clock input.	(5)
20	OCLK+	Odd pixel Positive LVDS differential clock input.	
21	GND	Ground	
22	ORX3-	Odd pixel Negative LVDS differential data input. Channel 3	(5)
23	ORX3+	Odd pixel Positive LVDS differential data input. Channel 3	
24	N.C.	No Connection	(2)
25	N.C.	No Connection	
26	N.C.	No Connection	
27	N.C.	No Connection	
28	ERX0-	Even pixel Negative LVDS differential data input. Channel 0	(5)
29	ERX0+	Even pixel Positive LVDS differential data input. Channel 0	
30	ERX1-	Even pixel Negative LVDS differential data input. Channel 1	
31	ERX1+	Even pixel Positive LVDS differential data input. Channel 1	
32	ERX2-	Even pixel Negative LVDS differential data input. Channel 2	
33	ERX2+	Even pixel Positive LVDS differential data input. Channel 2	

34	GND	Ground	
35	ECLK-	Even pixel Negative LVDS differential clock input	(5)
36	ECLK+	Even pixel Positive LVDS differential clock input	
37	GND	Ground	
38	ERX3-	Even pixel Negative LVDS differential data input. Channel 3	(5)
39	ERX3+	Even pixel Positive LVDS differential data input. Channel 3	
40	N.C.	No Connection	(2)
41	N.C.	No Connection	
42	GND	Ground	
43	GND	Ground	
44	GND	Ground	
45	GND	Ground	
46	GND	Ground	
47	N.C.	No Connection	(2)
48	VCC	Power input (+12V)	
49	VCC	Power input (+12V)	
50	VCC	Power input (+12V)	
51	VCC	Power input (+12V)	

Note (1) LVDS connector pin order defined as follows

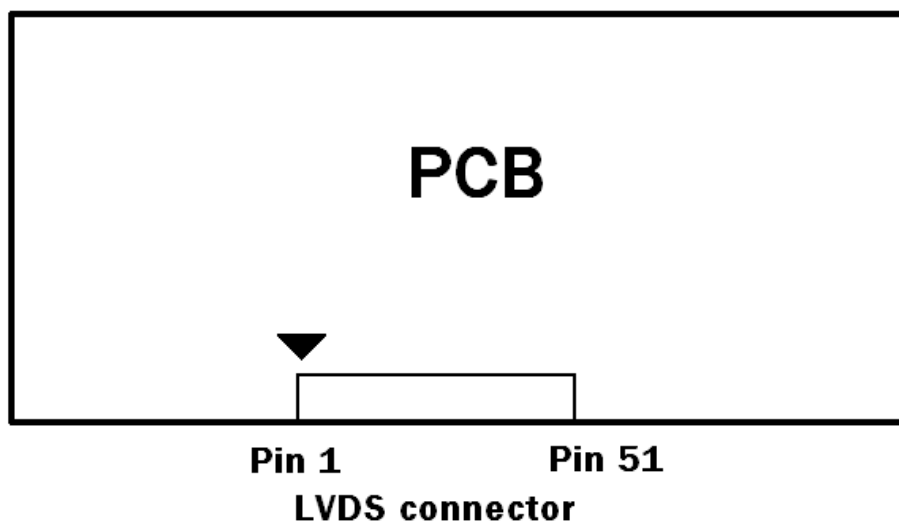

Note (2) Reserved for internal use. Please leave it open.

Note (3)

SELLVDS	Mode
L	JEIDA
H(default)	VESA

L: Connect to GND, H: Connect to Open or +3.3V

Note (4) LVDS signal pin connected to the LCM side has the following diagram. R1 in the system side should be less than 1K Ohm. ($R1 < 1K \text{ Ohm}$)

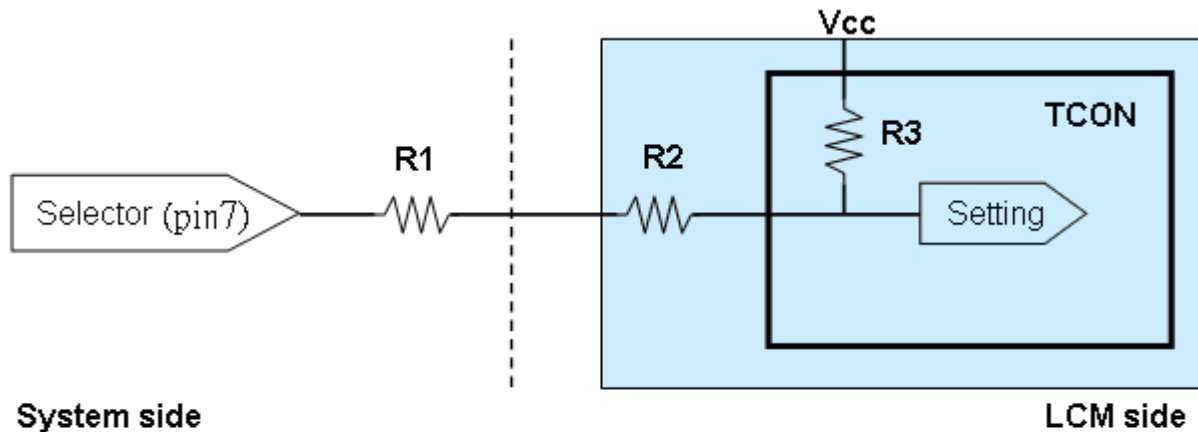

System side
 $R1 < 1K$

Note (5) Two pixel data send into the module for every clock cycle. The first pixel of the frame is odd pixel and the second pixel is even pixel.

Note (6) LVDS connector mating dimension range request is 0.93mm~1.0mm as follow:

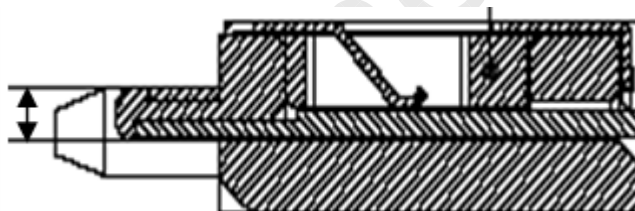

5.2 BACKLIGHT UNIT

The pin configuration for the housing and the leader wire is shown in the table below.

CN2: FF01-431-123A (FCN) or 196388-12041-3 (P-TWO)

Pin No	Symbol	Feature
1	VLED+	Positive of LED String
2	VLED+	
3	VLED+	
4	NC	NC
5	VLED-	Negative of LED String
6	VLED-	
7	VLED-	
8	VLED-	
9	VLED-	
10	VLED-	
11	VLED-	
12	VLED-	

5.3 CONVERTER UNIT

CN1(Header): CI0114M1HR0-LA (CvilLux) or JH2-D4-143N (FCN)

Pin No	Symbol	Feature
1	VBL	+24V
2		
3		
4		
5		
6	GND	GND
7		
8		
9		
10		
11	ERR	Normal (GND) Abnormal (Open collector)
12	BLON	BL ON/OFF
13	NC	NC
14	E_PWM	External PWM Control

Notice :

1. If Pin14 is open, E_PWM is 100% duty.

CN3(Header): FF01-431-123A (FCN) or 196388-12041-3 (P-TWO)

Pin No	Symbol	Feature
1	VLED-	Negative of LED String
2	VLED-	
3	VLED-	
4	VLED-	
5	VLED-	
6	VLED-	
7	VLED-	
8	VLED-	
9	NC	NC
10	VLED+	Positive of LED String
11	VLED+	
12	VLED+	

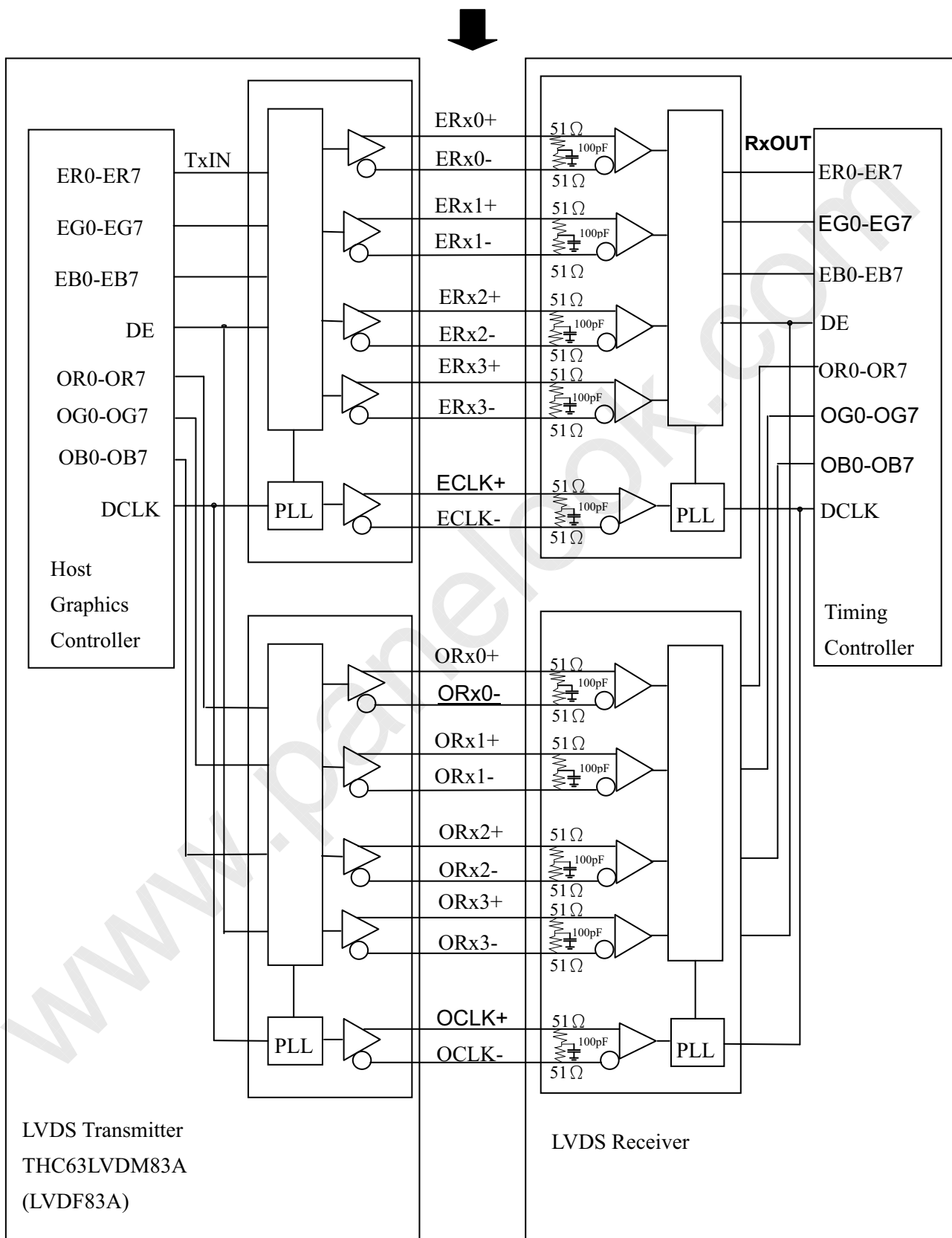
5.4 BLOCK DIAGRAM OF INTERFACE

ER0~ER7: Even pixel R data

EG0~EG7: Even pixel G data

EB0~EB7: Even pixel B data

OR0~OR7: Odd pixel R data

OG0~OG7: Odd pixel G data

OB0~OB7: Odd pixel B data

DE: Data enable signal

DCLK: Data clock signal

Note (1) The system must have the transmitter to drive the module.

Note (2) LVDS cable impedance shall be 50 ohms per signal line or about 100 ohms per twist-pair line when it is used differentially.

Note (3) Two pixel data send into the module for every clock cycle. The first pixel of the frame is odd pixel and the second pixel is even pixel.

5.5 LVDS INTERFACE

VESA Format : SELLVDS = H or Open

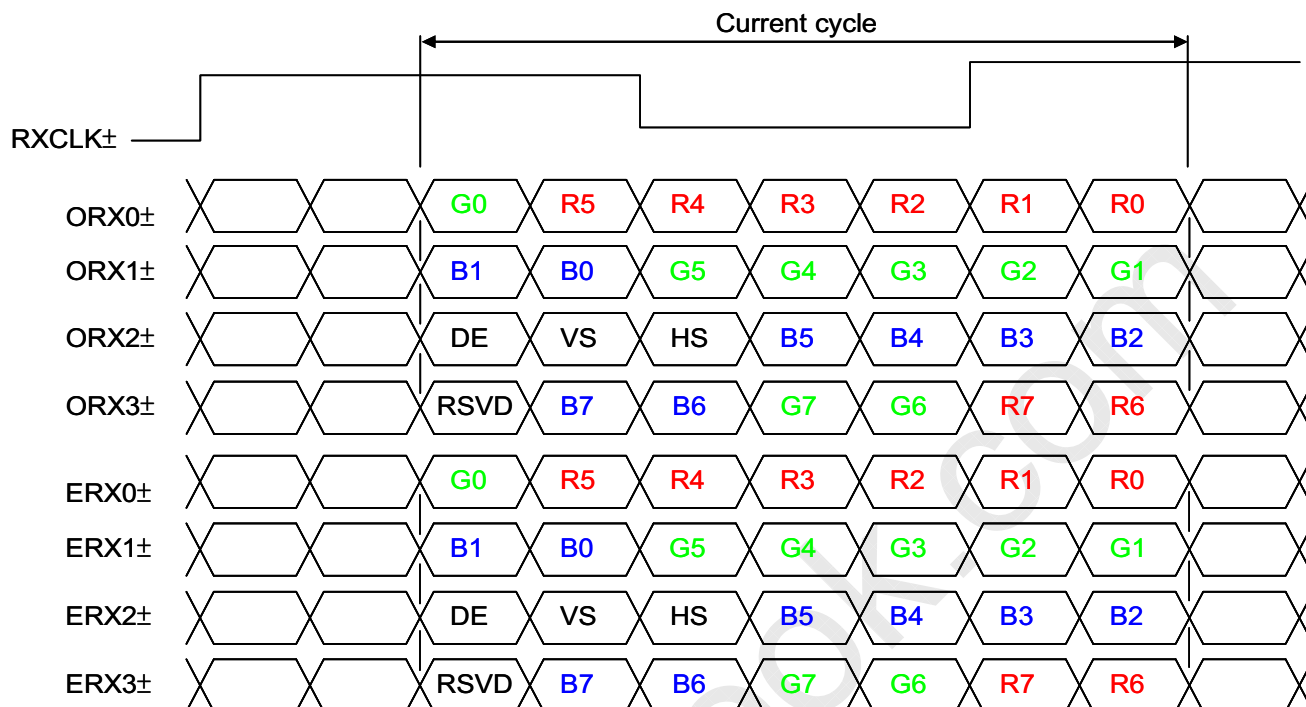

JEIDA Format : SELLVDS = L

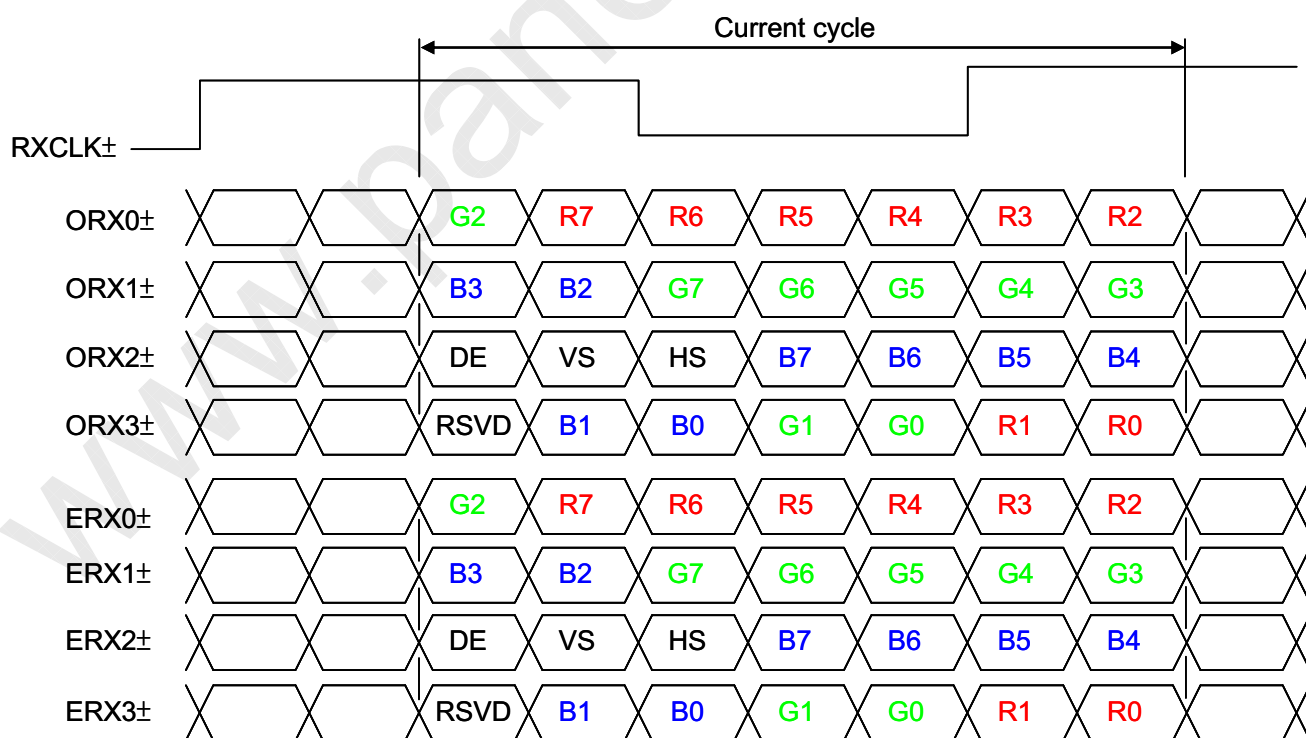

R0~R7: Pixel R Data (7; MSB, 0; LSB)

G0~G7: Pixel G Data (7; MSB, 0; LSB)

B0~B7: Pixel B Data (7; MSB, 0; LSB)

DE: Data enable signal

DCLK : Data clock signal

Note: (1) RSVD (reserved) pins on the transmitter shall be “H” or “L”.

5.6 COLOR DATA INPUT ASSIGNMENT

The brightness of each primary color (red, green and blue) is based on the 8-bit gray scale data input for the color. The higher the binary input, the brighter the color. The table below provides the assignment of the color versus data input.

Color		Data Signal																							
		Red								Green								Blue							
		R7	R6	R5	R4	R3	R2	R1	R0	G7	G6	G5	G4	G3	G2	G1	G0	B7	B6	B5	B4	B3	B2	B1	B0
Basic Colors	Black	0	0	0	0	0	0	0	0	0	0	0	0	0	0	0	0	0	0	0	0	0	0	0	0
	Red	1	1	1	1	1	1	1	1	0	0	0	0	0	0	0	0	0	0	0	0	0	0	0	0
	Green	0	0	0	0	0	0	0	0	1	1	1	1	1	1	1	1	0	0	0	0	0	0	0	0
	Blue	0	0	0	0	0	0	0	0	0	0	0	0	0	0	0	0	1	1	1	1	1	1	1	1
	Cyan	0	0	0	0	0	0	0	0	1	1	1	1	1	1	1	1	1	1	1	1	1	1	1	1
	Magenta	1	1	1	1	1	1	1	1	0	0	0	0	0	0	0	0	1	1	1	1	1	1	1	1
	Yellow	1	1	1	1	1	1	1	1	1	1	1	1	1	1	1	1	0	0	0	0	0	0	0	0
	White	1	1	1	1	1	1	1	1	1	1	1	1	1	1	1	1	1	1	1	1	1	1	1	1
Gray Scale Of Red	Red (0) / Dark	0	0	0	0	0	0	0	0	0	0	0	0	0	0	0	0	0	0	0	0	0	0	0	0
	Red (1)	0	0	0	0	0	0	0	1	0	0	0	0	0	0	0	0	0	0	0	0	0	0	0	0
	Red (2)	0	0	0	0	0	0	1	0	0	0	0	0	0	0	0	0	0	0	0	0	0	0	0	0
	:	:	:	:	:	:	:	:	:	:	:	:	:	:	:	:	:	:	:	:	:	:	:	:	:
	:	:	:	:	:	:	:	:	:	:	:	:	:	:	:	:	:	:	:	:	:	:	:	:	:
	Red (253)	1	1	1	1	1	1	0	1	0	0	0	0	0	0	0	0	0	0	0	0	0	0	0	0
	Red (254)	1	1	1	1	1	1	1	0	0	0	0	0	0	0	0	0	0	0	0	0	0	0	0	0
	Red (255)	1	1	1	1	1	1	1	1	0	0	0	0	0	0	0	0	0	0	0	0	0	0	0	0
Gray Scale Of Green	Green (0) / Dark	0	0	0	0	0	0	0	0	0	0	0	0	0	0	0	0	0	0	0	0	0	0	0	0
	Green (1)	0	0	0	0	0	0	0	0	0	0	0	0	0	0	1	0	0	0	0	0	0	0	0	0
	Green (2)	0	0	0	0	0	0	0	0	0	0	0	0	0	1	0	0	0	0	0	0	0	0	0	0
	:	:	:	:	:	:	:	:	:	:	:	:	:	:	:	:	:	:	:	:	:	:	:	:	:
	:	:	:	:	:	:	:	:	:	:	:	:	:	:	:	:	:	:	:	:	:	:	:	:	:
	Green (253)	0	0	0	0	0	0	0	0	1	1	1	1	1	1	0	1	0	0	0	0	0	0	0	0
	Green (254)	0	0	0	0	0	0	0	0	1	1	1	1	1	1	1	0	0	0	0	0	0	0	0	0
	Green (255)	0	0	0	0	0	0	0	0	1	1	1	1	1	1	1	1	0	0	0	0	0	0	0	0

Note (1) Please make sure the range of frame rate has follow the below equation :

$$F_{clk(in)(max)} \geq F_{r6} \times T_v \times T_h$$

$$F_{r5} \times T_v \times T_h \geq F_{clk(in)(min)}$$

Note (2) This module is operated in DE only mode and please follow the input signal timing diagram below :

INPUT SIGNAL TIMING DIAGRAM

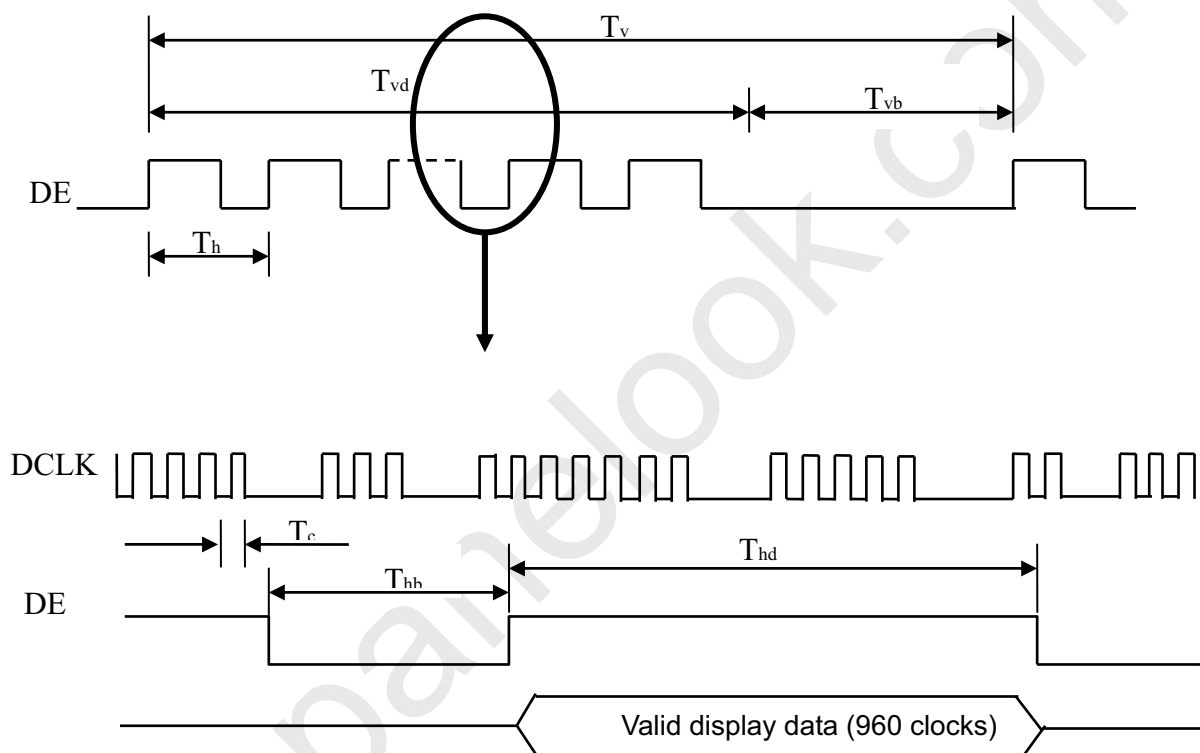

Note (3) The input clock cycle-to-cycle jitter is defined as below figures. $Trcl = |T_1 - T_1|$

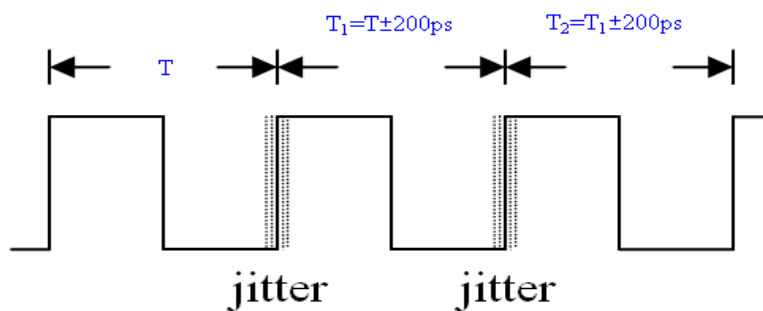

Note (4) The SSCG (Spread spectrum clock generator) is defined as below figures.

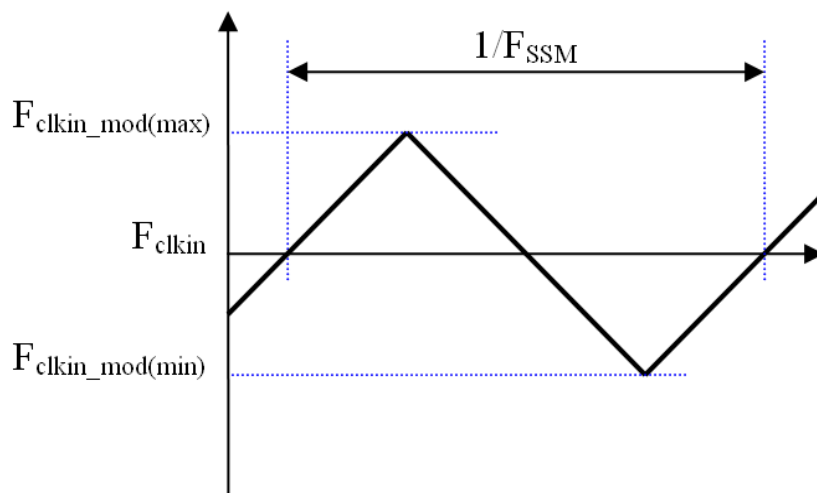

Note (5) The LVDS timing diagram and receiver skew margin is defined and showing as the following figures.

LVDS RECEIVER INTERFACE TIMING DIAGRAM

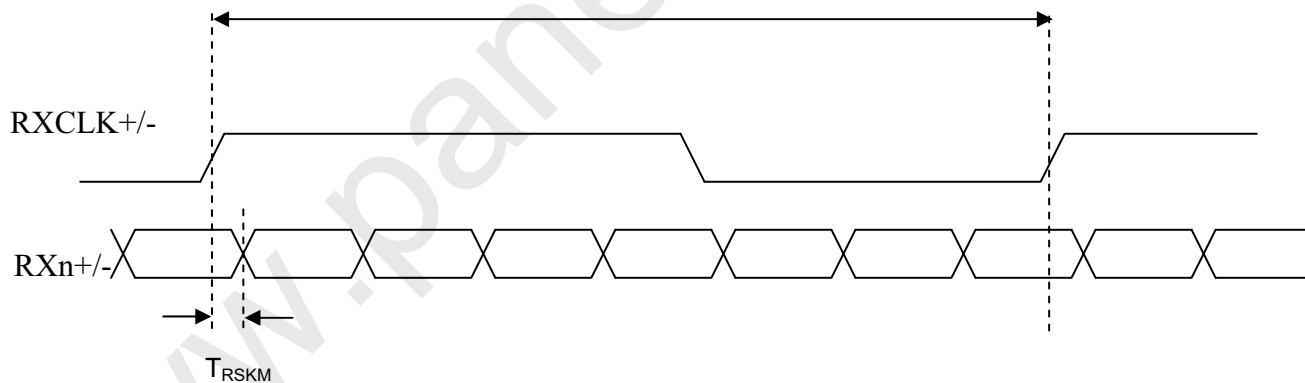

6.2 POWER ON/OFF SEQUENCE

($T_a = 25 \pm 2 \text{ }^\circ\text{C}$)

To prevent a latch-up or DC operation of LCD module, the power on/off sequence should be as the diagram below.

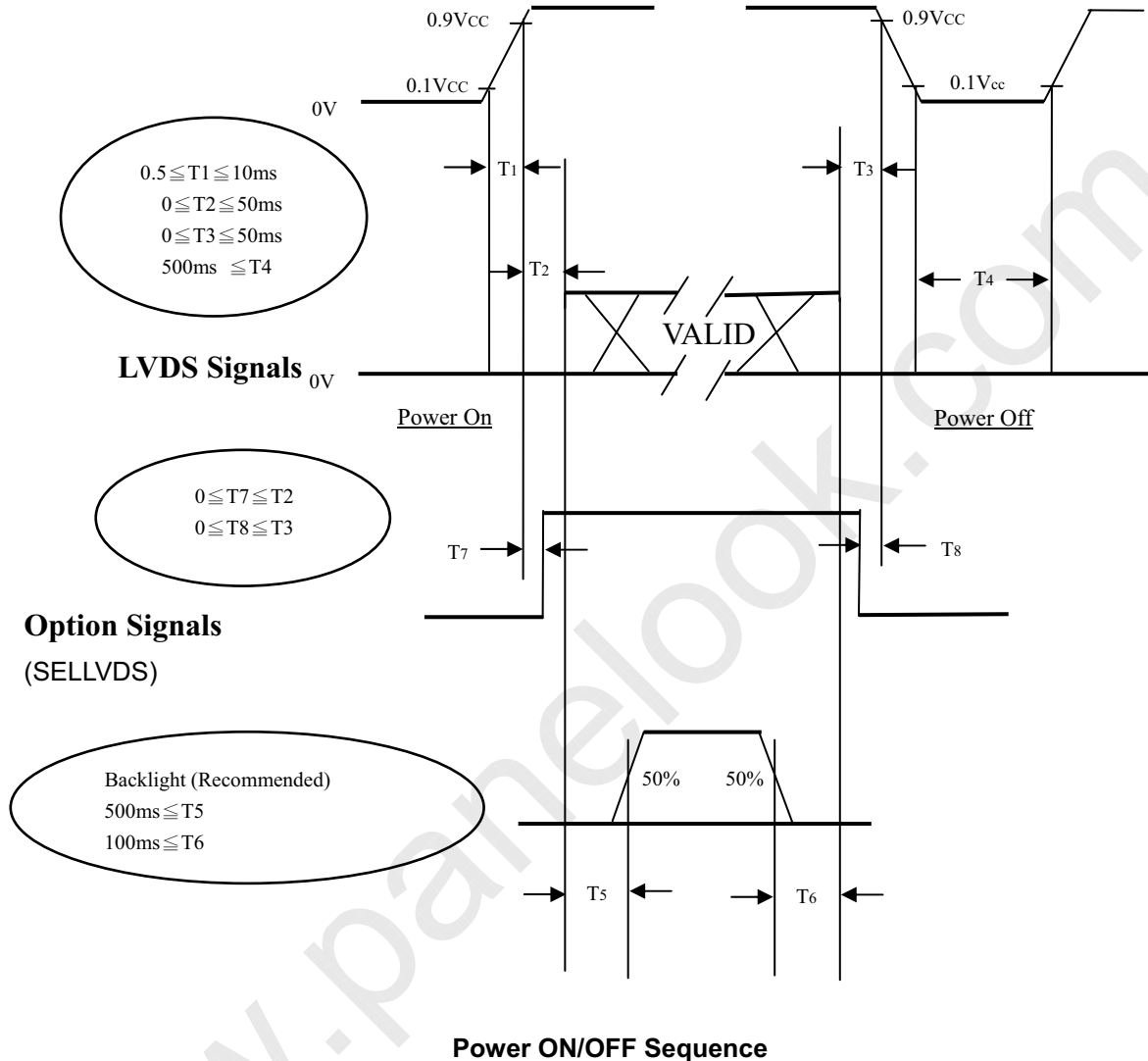

Note (1) The supply voltage of the external system for the module input should follow the definition of V_{CC} .

Note (2) Apply the LED voltage within the LCD operation range. When the backlight turns on before the LCD operation or the LCD turns off before the backlight turns off, the display may momentarily become abnormal screen.

Note (3) In case of V_{CC} is in off level, please keep the level of input signals on the low or high impedance.
If $T_2 < 0$, that maybe cause electrical overstress failure.

Note (4) T_4 should be measured after the module has been fully discharged between power off and on period.

Note (5) Interface signal shall not be kept at high impedance when the power is on.

7. OPTICAL CHARACTERISTICS

7.1 TEST CONDITIONS

Item	Symbol	Value	Unit
Ambient Temperature	Ta	25±2	°C
Ambient Humidity	Ha	50±10	%RH
Supply Voltage	VCC	12	V
Input Signal	According to typical value in "3. ELECTRICAL CHARACTERISTICS"		
LED Current	IL	145±4	mA
Vertical Frame Rate	Fr	60	Hz

The LCD module should be stabilized at given temperature for 1 hour to avoid abrupt temperature change during measuring. In order to stabilize the luminance, the measurement should be executed after lighting backlight for 1 hour in a windless room.

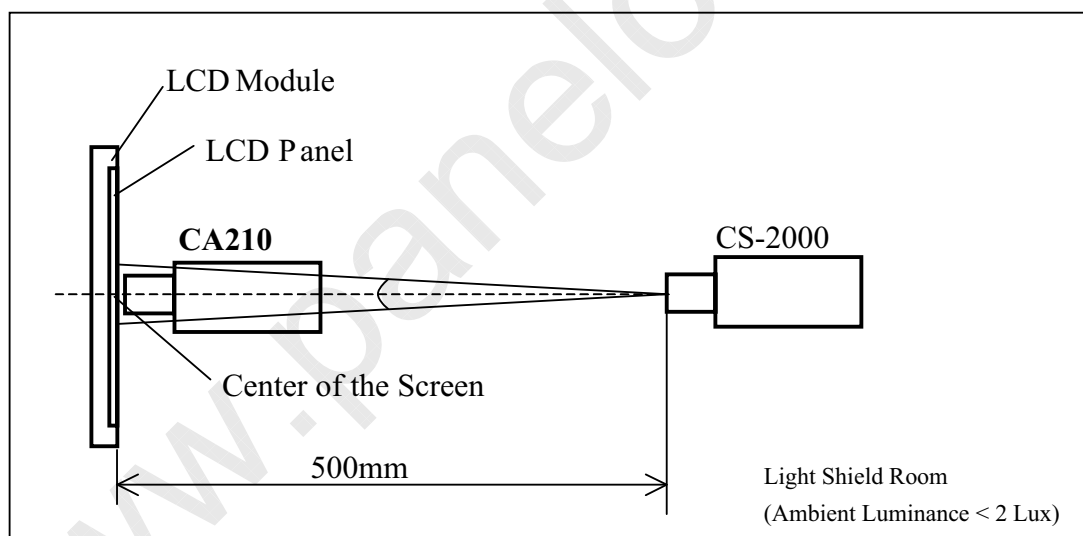

7.2 OPTICAL SPECIFICATIONS

The relative measurement methods of optical characteristics are shown in 7.2. The following items should be measured under the test conditions described in 7.1 and stable environment shown in 7.1.

Item		Symbol	Condition	Min.	Typ.	Max.	Unit	Note			
Contrast Ratio		CR	$\theta_x=0^\circ, \theta_y=0^\circ$ Viewing angle at normal direction	2450	3500		-	(2)			
Response Time (VA)		Gray to gray			9.5	19	ms	(3)			
Center Luminance of White		L_c		240	300		cd/m^2	(4)			
White Variation		δW				1.3	-	(6)			
Cross Talk		CT				4	%	(5)			
Color Chromaticity	Red	R_x		Typ. -0.03	Typ. +0.03	0.622	-	-			
		R_y				0.335	-				
	Green	G_x				0.311	-				
		G_y				0.615	-				
	Blue	B_x				0.149	-				
		B_y	0.058			-					
	White	W_x	0.280			-					
		W_y	0.290			-					
	Correlated color temperature					-	10000		-	K	-
	Color Gamut		C.G.			-	68		-	%	NTSC
Viewing Angle	Horizontal	θ_{x+}	CR \geq 20	80	88	-	Deg.	(1)			
		θ_{x-}									
	Vertical	θ_{y+}									
		θ_{y-}									

Note (1) Definition of Viewing Angle (θ_x , θ_y) :

Viewing angles are measured by Autronic Conoscope Cono-80

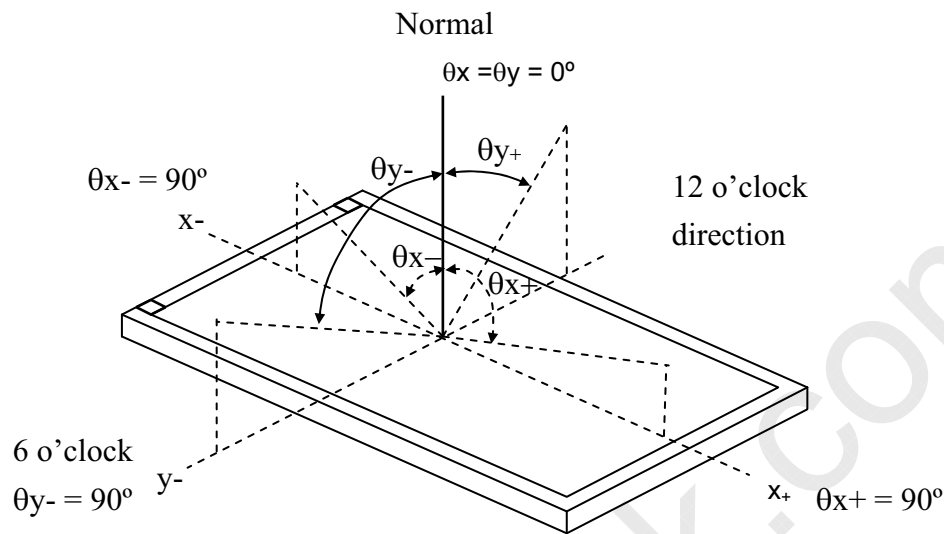

Note (2) Definition of Contrast Ratio (CR) :

The contrast ratio can be calculated by the following expression.

$$\text{Contrast Ratio (CR)} = \frac{\text{Surface Luminance of L255}}{\text{Surface Luminance of L0}}$$

L255: Luminance of gray level 255

L 0: Luminance of gray level 0

CR = CR (5), where CR (X) is corresponding to the Contrast Ratio of the point X at the figure in Note (6).

Note (3) Definition of Gray-to-Gray Switching Time:

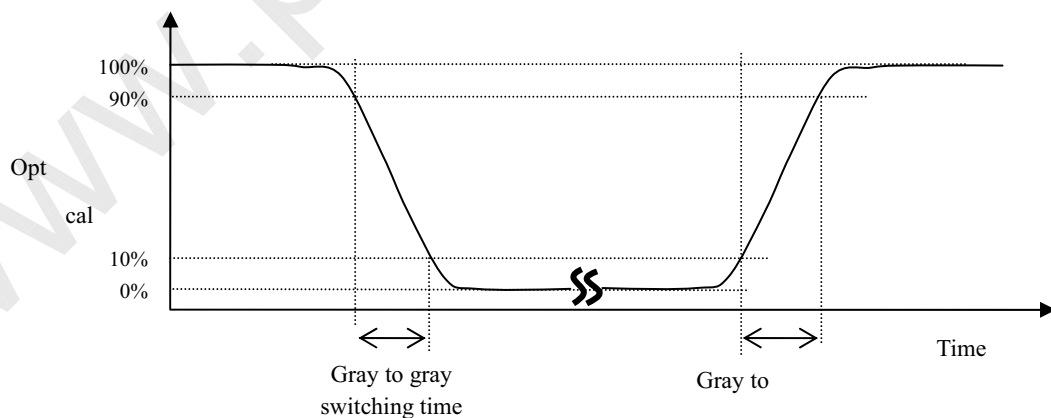

The driving signal means the signal of gray level gray level (0, 63, 127, 191, 255)..Gray to gray average.
 Gray to gray average time means the average switching time of gray level (0, 63, 127, 191, 255)..Gray to gray average

Note (4) Definition of Luminance of White (LC):

Measure the luminance of gray level 255 at center point and 5 points

$L_C = L(5)$, where $L(X)$ is corresponding to the luminance of the point X at the figure in Note (6).

Note (5) Definition of Cross Talk (CT):

$$CT = |Y_B - Y_A| / Y_A \times 100 (\%)$$

Y_A = Luminance of measured location without gray level 255 pattern (cd/m^2)

Y_B = Luminance of measured location with gray level 255 pattern (cd/m^2)

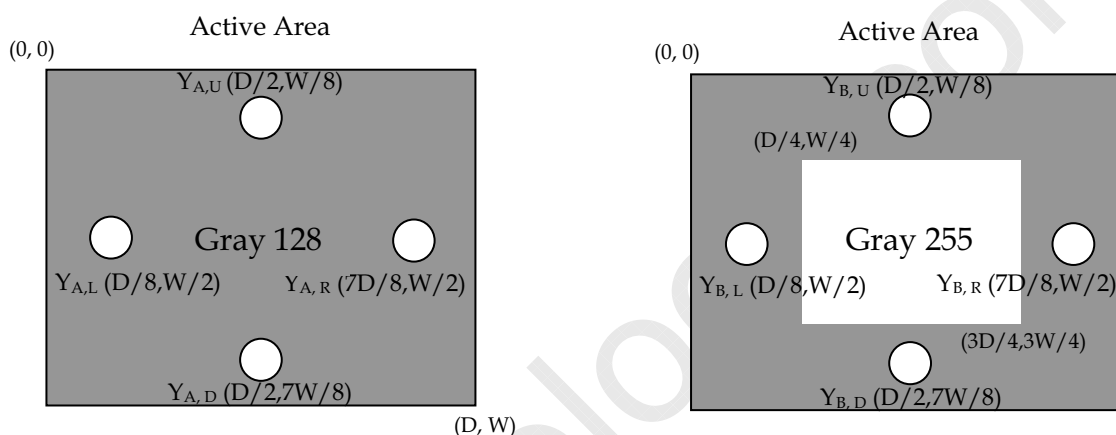

Note (6) Definition of White Variation (δW):

Measure the luminance of gray level 255 at 5 points

$$\delta W = \text{Maximum} [L(1), L(2), L(3), L(4), L(5)] / \text{Minimum} [L(1), L(2), L(3), L(4), L(5)]$$

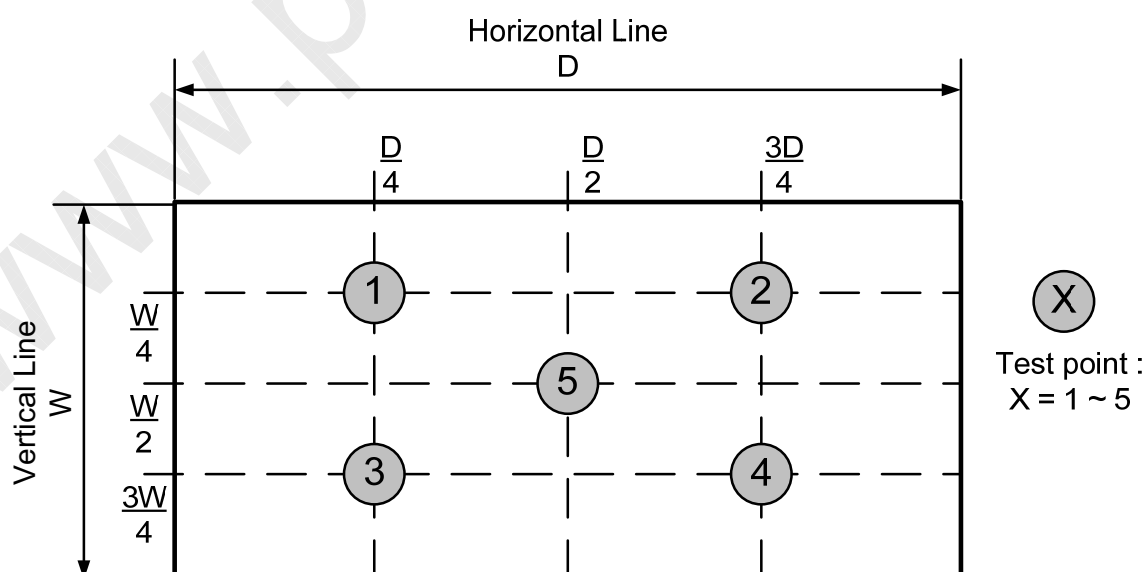

8. PRECAUTIONS

8.1 ASSEMBLY AND HANDLING PRECAUTIONS

- [1] Do not apply rough force such as bending or twisting to the module during assembly.
- [2] It is recommended to assemble or to install a module into the user's system in clean working areas. The dust and oil may cause electrical short or worsen the polarizer.
- [3] Do not apply pressure or impulse to the module to prevent the damage of LCD panel and Backlight.
- [4] Always follow the correct power-on sequence when the LCD module is turned on. This can prevent the damage and latch-up of the CMIS LSI chips.
- [5] Bezel of Set can not press or touch the panel surface. It will make light leakage or scrape.
- [6] Do not plug in or pull out the I/F connector while the module is in operation.
- [7] Do not disassemble the module.
- [8] Use a soft dry cloth without chemicals for cleaning, because the surface of polarizer is very soft and easily scratched.
- [9] Moisture can easily penetrate into LCD module and may cause the damage during operation.
- [10] When storing modules as spares for a long time, the following precaution is necessary.
 - [10.1] Do not leave the module in high temperature, and high humidity for a long time. It is highly recommended to store the module with temperature from 0 to 35°C at normal humidity without condensation.
 - [10.2] The module shall be stored in dark place. Do not store the TFT-LCD module in direct sunlight or fluorescent light.
- [11] When ambient temperature is lower than 10°C, the display quality might be reduced. For example, the response time will become slow, and the starting voltage of CCFL will be higher than that of room temperature.

8.2 SAFETY PRECAUTIONS

- [1] The startup voltage of a Backlight is approximately 1000 Volts. It may cause an electrical shock while assembling with the converter. Do not disassemble the module or insert anything into the Backlight unit.
- [2] If the liquid crystal material leaks from the panel, it should be kept away from the eyes or mouth. In case of contact with hands, skin or clothes, it has to be washed away thoroughly with soap.
- [3] After the module's end of life, it is not harmful in case of normal operation and storage.

9. DEFINITION OF LABELS

9.1 CMI MODULE LABEL

The barcode nameplate is pasted on each module as illustration, and its definitions are as following explanation.



- (a) Model Name: V390HJ1-LE1
- (b) Revision: Rev. XX, for example: A0, A1... B1, B2... or C1, C2...etc.
- (c) Serial ID: XXXXXXXYMDLNNNN

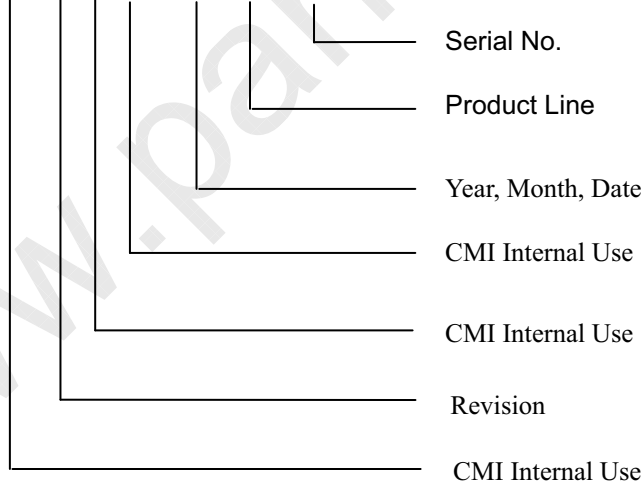

Serial ID includes the information as below:

- (a) Manufactured Date: Year: 0~9, for 2010~2019
Month: 1~9, A~C, for Jan. ~ Dec.
Day: 1~9, A~Y, for 1st to 31st, exclude I, O, and U.
- (b) Revision Code: Cover all the change
- (c) Serial No.: Manufacturing sequence of product
- (d) Product Line: 1 -> Line1, 2 -> Line 2, ...etc.

10. PACKAGING

10.1 PACKAGING SPECIFICATIONS

- (1) 7 LCD TV modules / 1 Box
- (2) Box dimensions : 954(L)x378(W)x602(H)mm
- (3) Weight : Approx. 56Kg(7 modules per carton)

10.2 PACKAGING METHOD

Figures 10-1 and 10-2 are the packing method

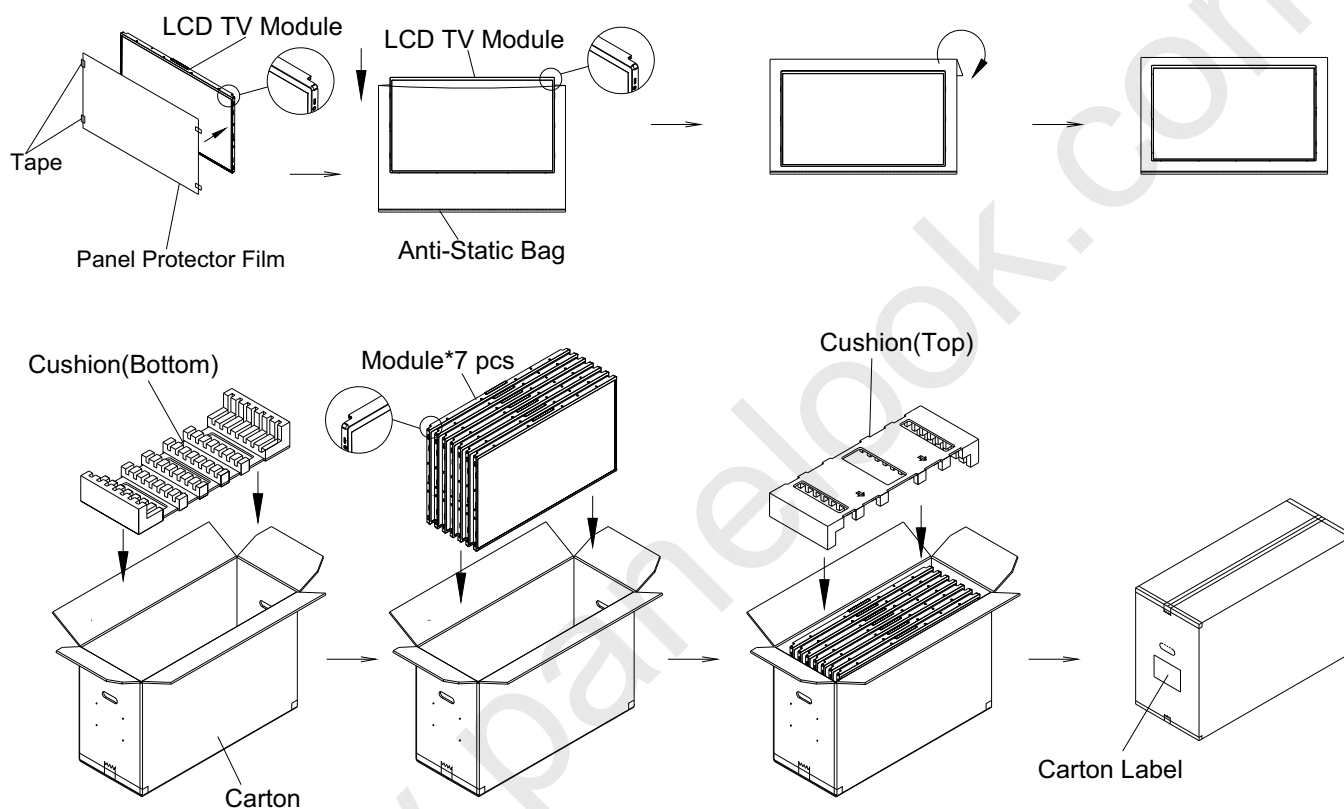
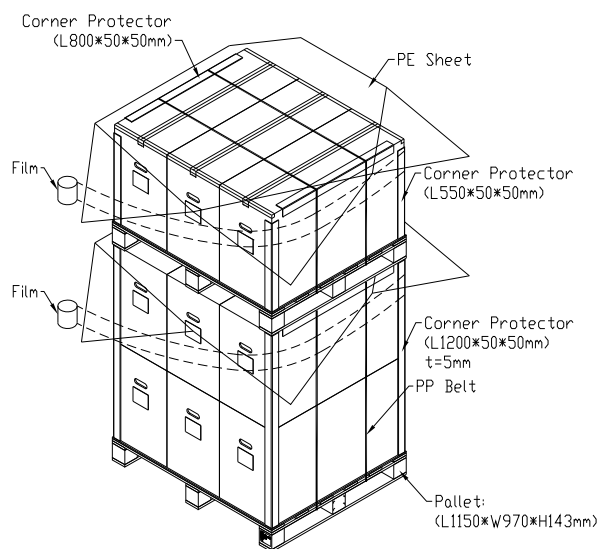

Figure 10-1 packing method

Sea / Land Transportation (40ft HQ / 40ft Container)



Air Transportation

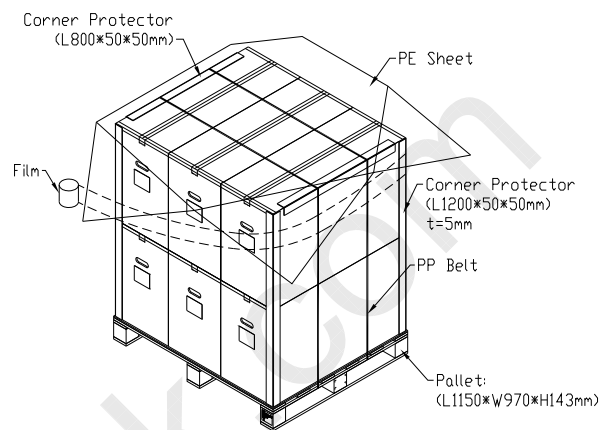

Figure 10-2 packing method

11. MECHANICAL CHARACTERISTIC

