

- Tentative Specification
- Preliminary Specification
- Approval Specification

MODEL NO.: V390HK1
SUFFIX: LS5

Rev. C9

Customer:	
APPROVED BY	SIGNATURE
Name / Title _____	_____
Note	
<hr/> Please return 1 copy for your confirmation with your signature and comments.	

Approved By	Checked By	Prepared By
Chao-Chun Chung	Roger Huang	WJ Chang

CONTENTS

1. GENERAL DESCRIPTION	5
1.1 OVERVIEW	5
1.2 FEATURES.....	5
1.3 APPLICATION	5
1.4 GENERAL SPECIFICATIONS	5
1.5 MECHANICAL SPECIFICATIONS	6
2. ABSOLUTE MAXIMUM RATINGS	7
2.1 ABSOLUTE RATINGS OF ENVIRONMENT	7
2.2 PACKAGE STORAGE.....	8
2.3 ELECTRICAL ABSOLUTE RATINGS	8
2.3.1 TFT LCD MODULE	8
2.3.2 BACKLIGHT CONVERTER UNIT	8
3. ELECTRICAL CHARACTERISTICS	9
3.1 TFT LCD MODULE (Ta = 25 ± 2 °C).....	9
3.2 BACKLIGHT CONVERTER UNIT	12
3.2.1 LED LIGHT BAR CHARACTERISTICS (Ta = 25 ± 2 °C).....	12
3.2.2 CONVERTER CHARACTERISTICS (Ta = 25 ± 2 °C)	12
3.2.3 CONVERTER INTERFACE CHARACTERISTICS	14
4. BLOCK DIAGRAM OF INTERFACE	16
4.1 TFT LCD MODULE	16
5. INTERFACE PIN CONNECTION	17
5.1 TFT LCD MODULE	17
5.2 BACKLIGHT UNIT.....	22
5.3 CONVERTER UNIT	22
5.4 BLOCK DIAGRAM OF INTERFACE	24
5.5 LVDS INTERFACE	26
5.6 COLOR DATA INPUT ASSIGNMENT	27
6. INTERFACE TIMING.....	28
6.1 INPUT SIGNAL TIMING SPECIFICATIONS (Ta = 25 ± 2 °C).....	28
6.1.1 Timing spec for Frame Rate = 50Hz	28
6.1.2 Timing spec for Frame Rate = 60Hz	29
6.2 POWER ON/OFF SEQUENCE.....	33

6.2.1 POWER ON/OFF SEQUENCE(Ta = 25 ± 2 °C).....	33
6.2.1 (2D/3D MODE CHANGE SIGNAL SEQUENCE WITHOUT VCC TURN OFF AND TURN ON)	34
7. OPTICAL CHARACTERISTICS	35
7.1 TEST CONDITIONS.....	35
7.2 OPTICAL SPECIFICATIONS	36
8. PRECAUTIONS.....	41
8.1 ASSEMBLY AND HANDLING PRECAUTIONS	41
8.2 SAFETY PRECAUTIONS	41
9. DEFINITION OF LABELS.....	42
9.1 CMI MODULE LABEL	42
10. PACKAGING.....	43
10.1 PACKAGING SPECIFICATIONS	43
10.2 PACKAGING METHOD.....	43
11. MECHANICAL CHARACTERISTIC.....	45
APPENDIX A	48

REVISION HISTORY

Version	Date	Page(New)	Section	Description
Ver. 2.0	Nov. 21, 2011	All	All	Approval specification was first issued.
Ver. 2.1	Jan. 19, 2012	5	1.2	Fast response time: 8ms -> 8.5ms.
			1.4	Backlight Power consumption : 38.4W -> 48.5W, Total Power consumption : 50.01W -> 60.14W.
		12	3.2.1	Modify "LED LIGHT BAR CHARACTERISTICS".
		12	3.2.2	Modify "CONVERTER CHARACTERISTICS".
		13	3.2.2	Modify the Note(2) average LED current from 159 to 153.7 mA. Renew the diagram of Note(6).
		14	3.2.3	Add External PWM Frequency.
		19	5.1	Modify Note (4) change $V_{IL}=0\sim 0.8$ V, $V_{IH}=2.0\sim 3.3$ V to be $V_{IL}=0\sim 0.7$ V, $V_{IH}=2.7\sim 3.3$ V. Note (5) Local dimming enable selection: H=Connect to +3.3V or Open.
		28	6.1	Modify Setup & Hold Time to be Receiver Skew Margin T_{RSKM} min.= -400 / Max.= 400 ps.
		32	6.1.2	Renew Note(5) and its diagram. Modify the frequency of Note(6).
		35	7.1	Modify LED Current IL from 150 to 145 ± 4 mA.
		36	7.2	Modify "OPTICAL SPECIFICATIONS".
		48	A.1	Modify the Command data, Preamble data, I2C data.
Ver. 3.0	Feb. 23, 2012	6	1.5	Rear material change from AL to SECC, and modify the weight.
		45~47	11	Update ME Drawing.

1. GENERAL DESCRIPTION

1.1 OVERVIEW

V390HK1-LS5 is a 39" TFT Liquid Crystal Display module with LED Backlight unit and 2ch-LVDS interface. This module supports 1920 x 1080 Full HDTV format and can display 16.7M colors (8-bit). The converter module for backlight is built-in.

1.2 FEATURES

- High brightness (350 nits)
- High contrast ratio (5000:1)
- Fast response time (Gray to gray average 8.5 ms)
- High color saturation (NTSC 68%)
- Full HDTV (1920 x 1080 pixels) resolution, true HDTV format
- LVDS (Low Voltage Differential Signaling) interface
- Ultra wide viewing angle : Super MVA technology
- Viewing Angle : 176(H)/176(V) (CR ≥ 20) VA Technology
- RoHs compliance

1.3 APPLICATION

- Standard Living Room TVs
- Public Display Application
- Home Theater Application
- MFM Application

1.4 GENERAL SPECIFICATIONS

Item	Specification	Unit	Note
Active Area	853.92 (H) x480.33 (V)	mm	(1)
Bezel Opening Area	858.92 (H) x485.33 (V)	mm	
Driver Element	a-si TFT active matrix	-	-
Pixel Number	1920 x R.G.B. x 1080	pixel	-
Pixel Pitch(Sub Pixel)	0.14825 (H) x 0.44475 (V)	mm	-
Pixel Arrangement	RGB vertical stripe	-	-
Power consumption	(60.14W (LVDS input Power 11.64W + LED Backlight Power 48.5W))	Watt	(2)
Display Colors	16.7M	color	-
Display Operation Mode	Transmissive mode / Normally Black	-	-
Surface Treatment	Anti-Glare coating (Haze 3.5%) Hard Coating (3H)	-	(3)

Note (1) Please refer to the attached drawings in chapter 9 for more information about the front and back outlines.

Note (2) Please refer sec 3.1 and 3.2 for more information of Power consumption

Note (3) The spec. of the surface treatment is temporarily for this phase. CMI reserves the rights to change this feature.

1.5 MECHANICAL SPECIFICATIONS

Item		Min.	Typ.	Max.	Unit	Note
Module Size	Horizontal (H)	877.72	878.72	879.72	mm	(1)
	Vertical (V)	509.23	510.23	511.23	mm	(1)
	Depth (D)	15.2	16.2	17.2	mm	(2)
	Depth (D)	26	27	28	mm	(3)
Weight		7270	7570	7870	g	-

Note (1) Please refer to the attached drawings for more information of front and back outline dimensions.

Note (2) Module Depth is between bezel to T-CON cover.

Note (3) Module Depth is between bezel to Converter cover.

2. ABSOLUTE MAXIMUM RATINGS

2.1 ABSOLUTE RATINGS OF ENVIRONMENT

Item	Symbol	Value		Unit	Note
		Min.	Max.		
Storage Temperature	TST	-20	+60	°C	(1)
Operating Ambient Temperature	TOP	0	50	°C	(1), (2)
Shock (Non-Operating)	SNOP	-	50	G	(3), (5)
Vibration (Non-Operating)	VNOP	-	1.0	G	(4), (5)

Note (1) Temperature and relative humidity range is shown in the figure below.

(a) 90 %RH Max. ($T_a \leq 40$ °C).

(b) Wet-bulb temperature should be 39 °C Max. ($T_a > 40$ °C).

(c) No condensation.

Note (2) The maximum operating temperature is based on the test condition that the surface temperature of display area is less than or equal to 65 °C with LCD module alone in a temperature controlled chamber. Thermal management should be considered in final product design to prevent the surface temperature of display area from being over 65 °C. The range of operating temperature may degrade in case of improper thermal management in final product design.

Note (3) 11 ms, half sine wave, 1 time for $\pm X$, $\pm Y$, $\pm Z$.

Note (4) 10 ~ 200 Hz, 10 min, 1 time each X, Y, Z.

Note (5) At testing Vibration and Shock, the fixture in holding the module has to be hard and rigid enough so that the module would not be twisted or bent by the fixture.

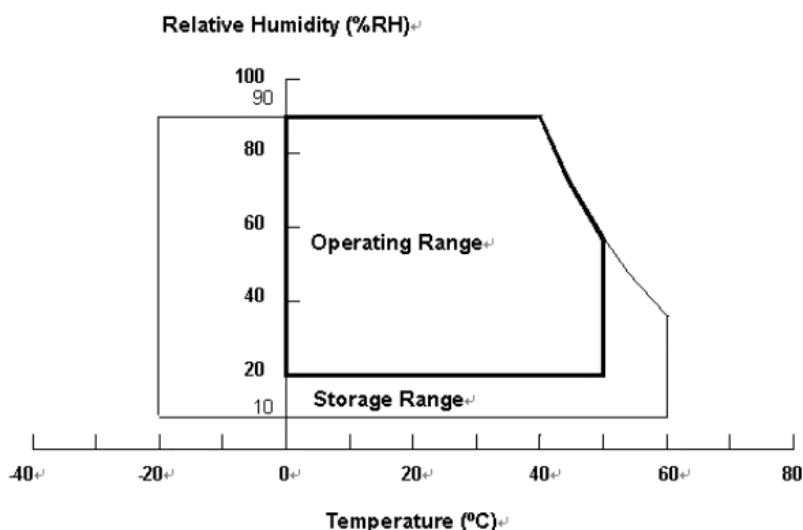

2.2 PACKAGE STORAGE

When storing modules as spares for a long time, the following precaution is necessary.

- (a) Do not leave the module in high temperature, and high humidity for a long time, It is highly recommended to store the module with temperature from 0 to 35 °C at normal humidity without condensation.
- (b) The module shall be stored in dark place. Do not store the TFT-LCD module in direct sunlight or fluorescent light.

2.3 ELECTRICAL ABSOLUTE RATINGS

2.3.1 TFT LCD MODULE

Item	Symbol	Value		Unit	Note
		Min.	Max.		
Power Supply Voltage	VCC	-0.3	13.5	V	(1)
Logic Input Voltage	VIN	-0.3	3.6	V	

2.3.2 BACKLIGHT CONVERTER UNIT

Item	Symbol	Value		Unit	Note
		Min.	Max.		
Light Bar Voltage	VW	—	60	VRMS	3D Mode
Converter Input Voltage	VBL	0	30	V	(1)
Control Signal Level	—	-0.3	7	V	(1), (3)

Note (1) Permanent damage to the device may occur if maximum values are exceeded. Functional operation should be restricted to the conditions described under normal operating conditions.

Note (2) No moisture condensation or freezing.

Note (3) The control signals include On/Off Control and External PWM Control.

3. ELECTRICAL CHARACTERISTICS

3.1 TFT LCD MODULE (Ta = 25 ± 2 °C)

Parameter	Symbol	Value			Unit	Note	
		Min.	Typ.	Max.			
Power Supply Voltage	V _{CC}	10.8	12	13.2	V	(1)	
Rush Current	I _{RUSH}	-	-	2.6	A	(2)	
Power Consumption	White Pattern	-	7.8	9.36	W	(3)	
	Black Pattern	-	7.2	8.64	W		
	Horizontal Stripe	-	11.64	13.68	W		
Power Supply Current	White Pattern	-	0.65	0.78	A	(4)	
	Black Pattern	-	0.6	0.72	A		
	Horizontal Stripe	-	0.97	1.14	A		
LVDS interface	Differential Input High Threshold Voltage	V _{LVTH}	+100	-	-	mV	(4)
	Differential Input Low Threshold Voltage	V _{LVTL}	-	-	-100	mV	
	Common Input Voltage	V _{CM}	1.0	1.2	1.4	V	
	Differential input voltage	V _{ID}	200	-	600	mV	
	Terminating Resistor	R _T	-	100	-	ohm	
CMOS interface	Input High Threshold Voltage	V _{IH}	2.7	-	3.3	V	
	Input Low Threshold Voltage	V _{IL}	0	-	0.7	V	

Note (1) The module should be always operated within the above ranges.

Note (2) Measurement Conditions:

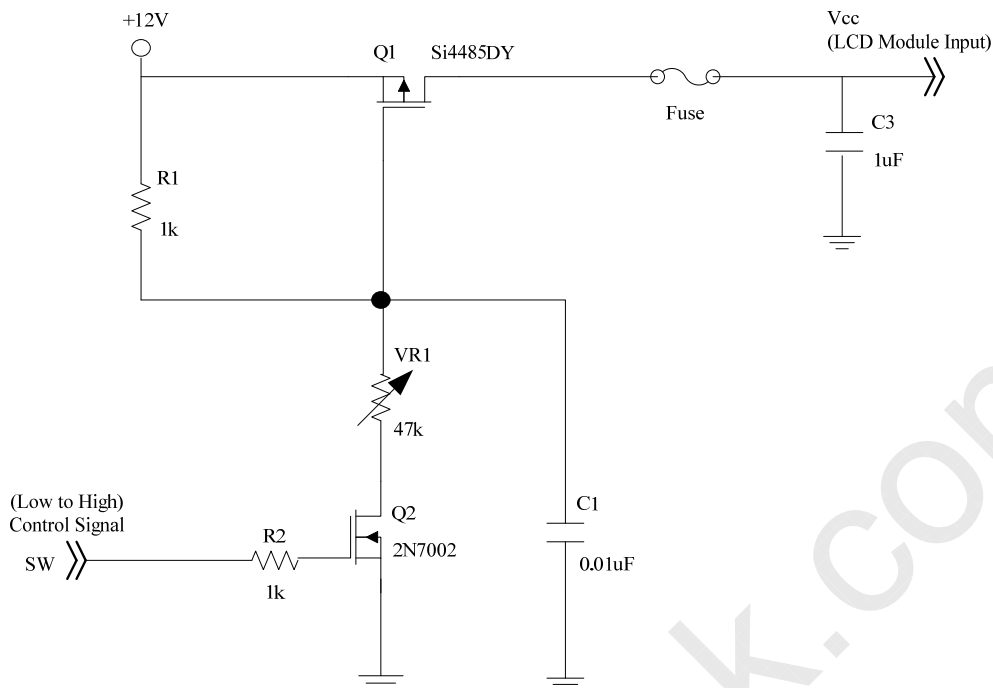

Vcc rising time is 470us

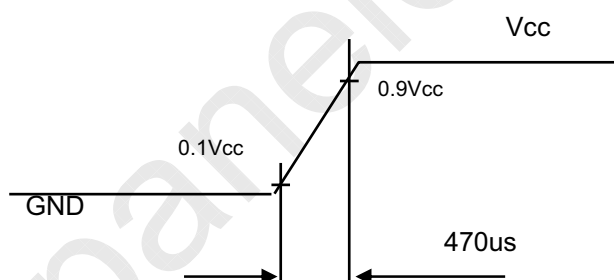

Note (3) The specified power consumption and power supply current is under the conditions at $V_{CC} = 12\text{ V}$, $T_a = 25 \pm 2\text{ }^\circ\text{C}$, $f_v = 120\text{ Hz}$, whereas a power dissipation check pattern below is displayed.

a. White Pattern



Active Area

b. Black Pattern



Active Area

c. Horizontal Stripe Pattern

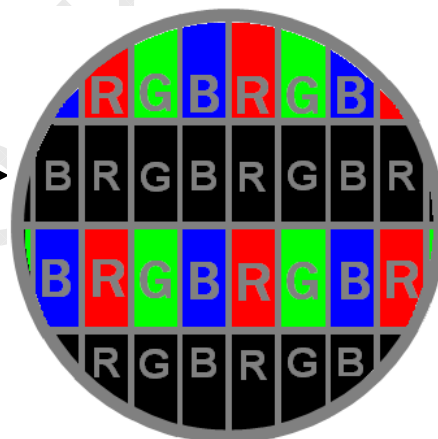
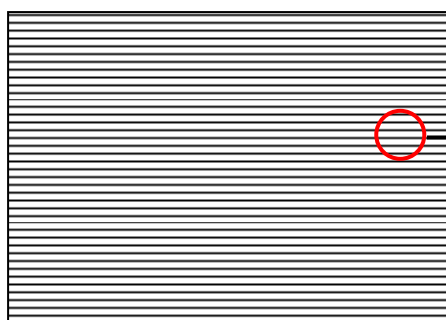

Note (4) The LVDS input characteristics are as follows:

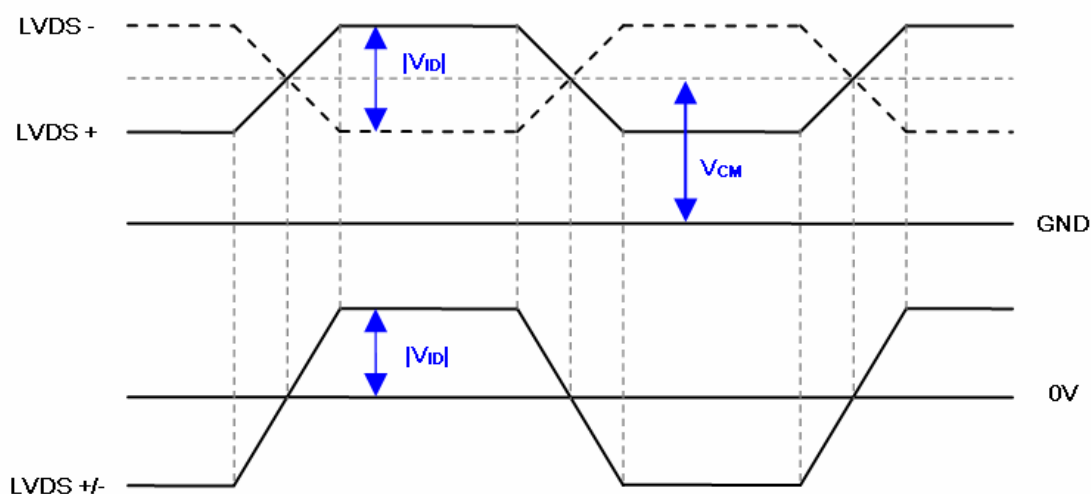

3.2 BACKLIGHT CONVERTER UNIT

3.2.1 LED LIGHT BAR CHARACTERISTICS (Ta = 25 ± 2 °C)

The backlight unit contains 1 pcs light bar.

Parameter	Symbol	Value			Unit	Note
		Min.	Typ.	Max.		
Total Current (1 String)	If	136.3	145.0	153.7	mA	
One String Current	IL(2D)	136.3	145.0	153.7	mA	
	IL(3D)	423	450.0	477	mApeak	3D ENA=ON
One String Voltage	VW	-	-	39.6	VDC	IL =145mA
One String Voltage Variation	ΔVW	-	-	1.5	V	
Life time	-	30,000	-	-	Hrs	(1)

Note (1) The lifetime is defined as the time which luminance of the LED decays to 50% compared to the initial value, Operating condition: Continuous operating at Ta = 25±2°C, IL =145mA

3.2.2 CONVERTER CHARACTERISTICS (Ta = 25 ± 2 °C)

Parameter	Symbol	Value			Unit	Note
		Min.	Typ.	Max.		
Power Consumption	PBL(2D)	-	48.5	55	W	(1), (2) IL = 145 mA
	PBL(3D)	-	36.72	42.23	W	(1), (2) IL=450mA.
Converter Input Voltage	VBL	22.8	24.0	25.2	VDC	
Converter Input Current	IBL(2D)	-	2.017	2.32	A	Non Dimming
	IBL(3D)	-	1.53	1.76	A	
Input Inrush Current	IR(2D)	-	2.3	2.65	Apeak	VBL=22.8V,(IL=typ.) (3), (6)
	IR(3D)	-	2.86	3.29	Apeak	VBL=22.8V,(IL=450mA) (3), (6)
Dimming Frequency	FB	170	180	190	Hz	(5)
Minimum Duty Ratio	DMIN	5	10	-	%	(4), (5)

Note (1) The power supply capacity should be higher than the total converter power consumption PBL. Since the pulse width modulation (PWM) mode was applied for backlight dimming, the driving current changed as PWM duty on and off. The transient response of power supply should be considered for the changing loading when converter dimming.

Note (2) The measurement condition of Max. value is based on 39" backlight unit under input voltage 24V, average LED current 153.7 mA at 2D Mode (LED current 477 mA_{peak} at 3D Mode) and lighting 1 hour later.

Note (3) For input inrush current measure, the VBL rising time from 10% to 90% is about 30ms.

Note (4) 5% minimum duty ratio is only valid for electrical operation.

Note (5) FB and DMIN are available only at 2D Mode.

Note (6) Below diagram is only for power supply design reference.

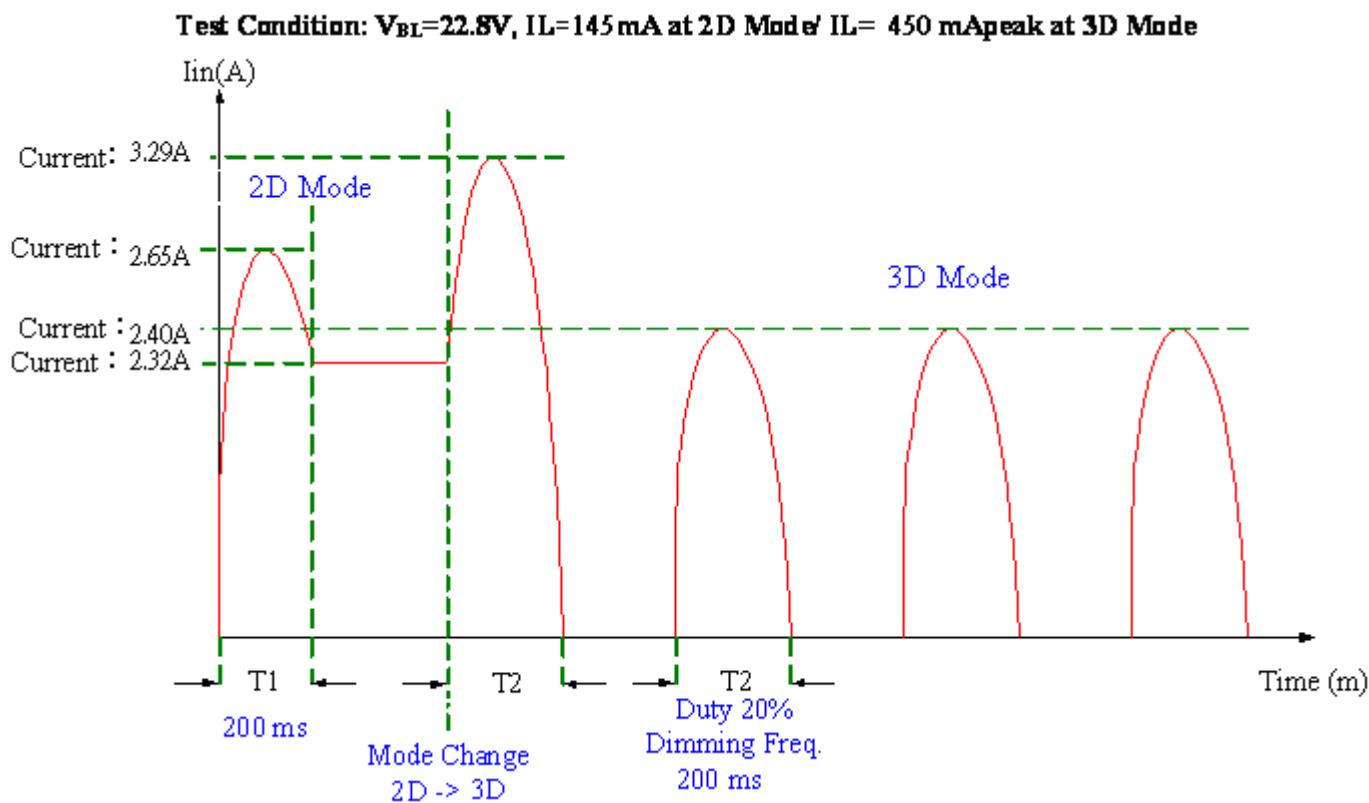

3.2.3 CONVERTER INTERFACE CHARACTERISTICS

Parameter	Symbol	Test Condition	Value			Unit	Note		
			Min.	Typ.	Max.				
On/Off Control Voltage	ON	VBLON	—	2.0	—	5.0	V		
	OFF		—	0	—	0.8	V		
External PWM Control Voltage	HI	VEPWM	—	2.0	—	5.25	V	Duty on	(5), (6)
	LO		—	0	—	0.8	V	Duty off	
External PWM Frequency	F_{EPWM}	—	150	160	170	Hz	Normal mode		
Error Signal	ERR	—	—	—	—	—	Abnormal: Open collector Normal: GND (4)		
VBL Rising Time	Tr1	—	30	—	—	ms	10%-90% V_{BL}		
Control Signal Rising Time	Tr	—	—	—	100	ms			
Control Signal Falling Time	Tf	—	—	—	100	ms			
PWM Signal Rising Time	TPWMR	—	—	—	50	us	(6)		
PWM Signal Falling Time	TPWMF	—	—	—	50	us			
Input Impedance	Rin	—	1	—	—	MΩ	EPWM, BLON		
PWM Delay Time	TPWM	—	100	—	—	ms	(6)		
BLON Delay Time	T_{on}	—	300	—	—	ms			
	T_{on1}	—	300	—	—	ms			
BLON Off Time	Toff	—	300	—	—	ms			

Note (1) The Dimming signal should be valid before backlight turns on by BLON signal. It is inhibited to change the external PWM signal during backlight turn on period.

Note (2) The power sequence and control signal timing are shown in the Fig.1. For a certain reason, the converter has a possibility to be damaged with wrong power sequence and control signal timing.

Note (3) While system is turned ON or OFF, the power sequences must follow as below descriptions:

Turn ON sequence: VBL → PWM signal → BLON

Turn OFF sequence: BLOFF → PWM signal → VBL

Note (4) When converter protective function is triggered, ERR will output open collector status.

Note (5) The EPWM interface that inserts a pull up resistor to 5V in Max Duty (100%), please refers to Fig.2.

Note (6) EPWM is available only at 2D Mode.

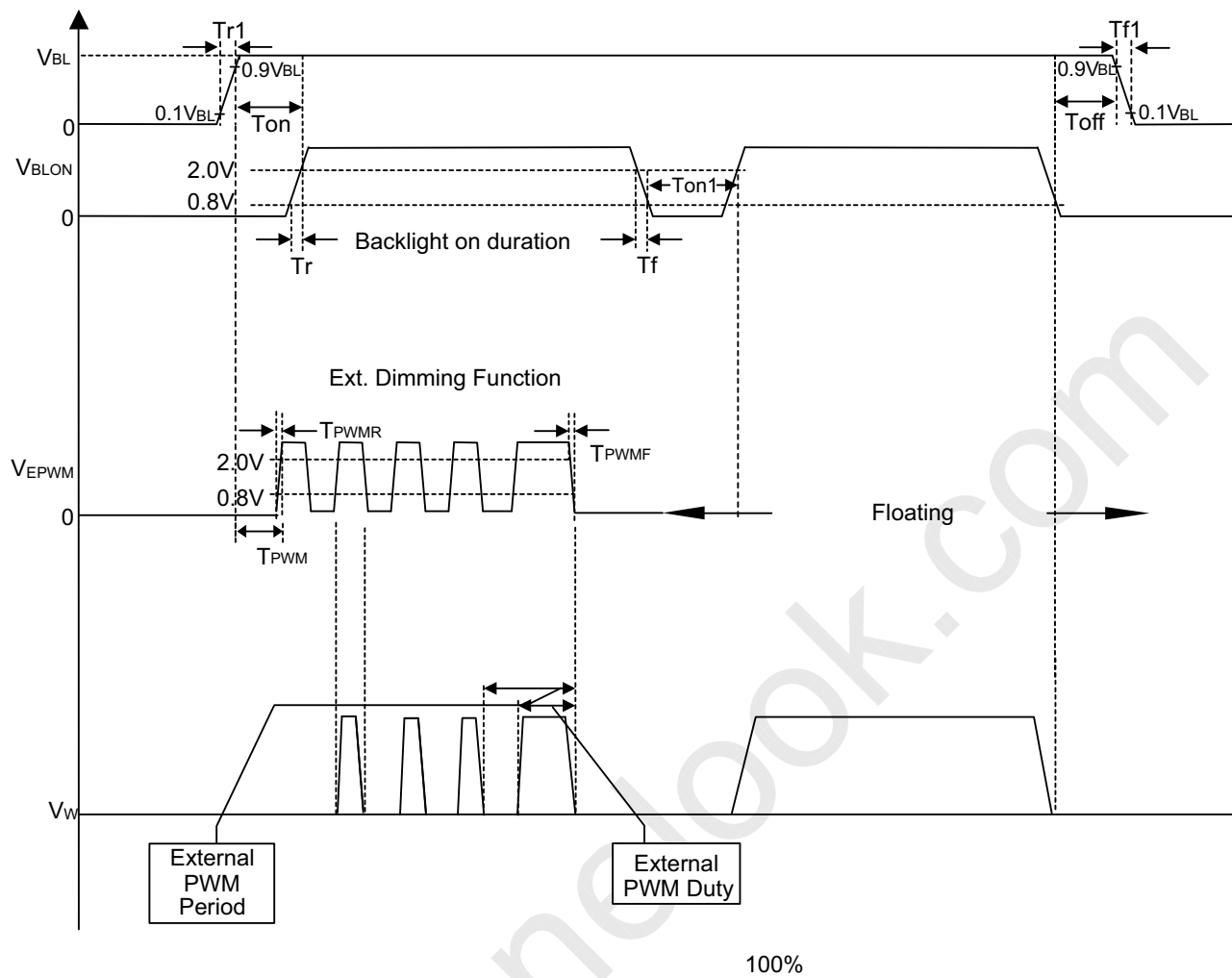

Fig. 1

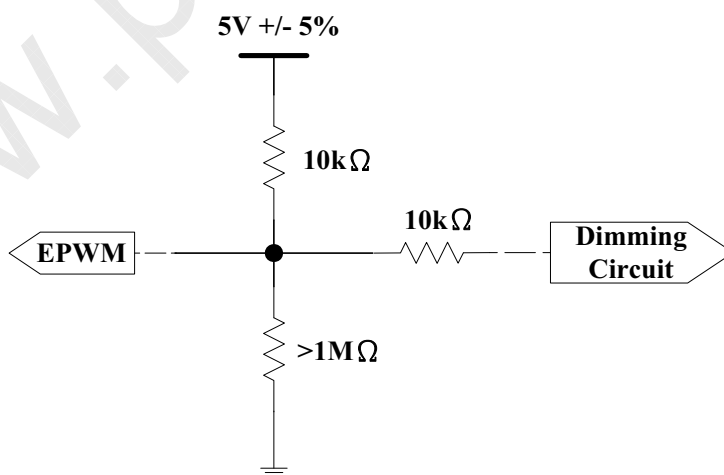
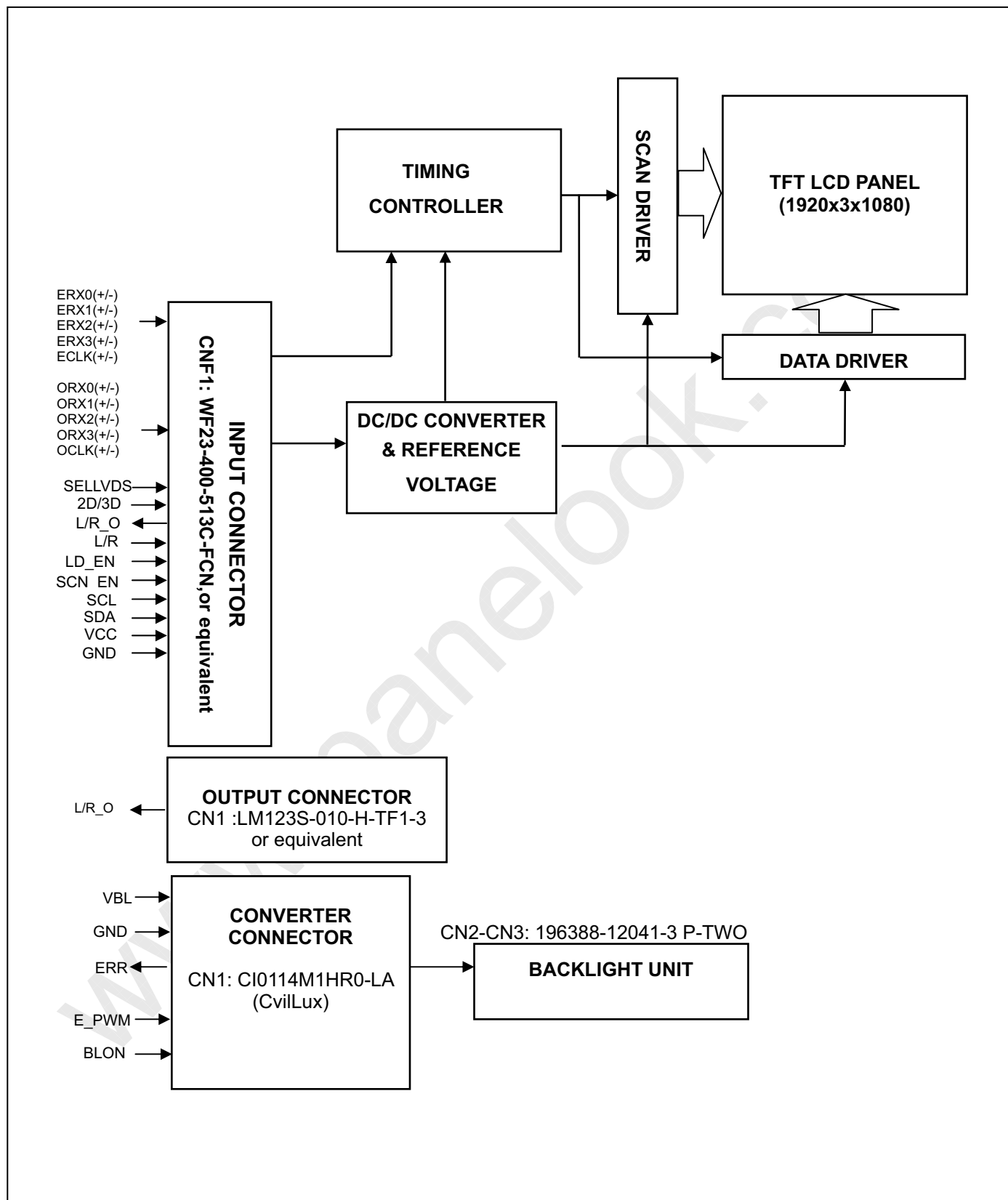

Fig. 2

4. BLOCK DIAGRAM OF INTERFACE
4.1 TFT LCD MODULE

5. INTERFACE PIN CONNECTION

5.1 TFT LCD MODULE

CNF1 Connector Pin Assignment: (WF23-400-513C-FCN or equivalent)

Pin	Name	Description	Note
1	N.C.	No Connection	(1)
2	SCL	I2C Serial Clock (for 3D format selection function)	(11)
3	SDA	I2C Serial Data (for 3D format selection function)	
4	N.C.	No Connection	(1)
5	L/R_O	Output signal for Left Right Glasses control	(10)
6	N.C.	No Connection	(1)
7	SELLVDS	Input signal for LVDS Data Format Selection	(2)(7)
8	N.C.	No Connection	(1)
9	N.C.	No Connection	
10	N.C.	No Connection	
11	GND	Ground	
12	ORX0-	Odd pixel Negative LVDS differential data input. Channel 0	(9)
13	ORX0+	Odd pixel Positive LVDS differential data input. Channel 0	
14	ORX1-	Odd pixel Negative LVDS differential data input. Channel 1	
15	ORX1+	Odd pixel Positive LVDS differential data input. Channel 1	
16	ORX2-	Odd pixel Negative LVDS differential data input. Channel 2	
17	ORX2+	Odd pixel Positive LVDS differential data input. Channel 2	
18	GND	Ground	
19	OCLK-	Odd pixel Negative LVDS differential clock input	(9)
20	OCLK+	Odd pixel Positive LVDS differential clock input	
21	GND	Ground	
22	ORX3-	Odd pixel Negative LVDS differential data input. Channel 3	(9)
23	ORX3+	Odd pixel Positive LVDS differential data input. Channel 3	
24	N.C.	No Connection	(1)
25	N.C.	No Connection	
26	2D/3D	Input signal for 2D/3D Mode Selection	(3)(6)(8)
27	L/R	Input signal for Left Right eye frame synchronous(Frame sequence mode)	(4)(8)
28	ERX0-	Even pixel Negative LVDS differential data input. Channel 0	(9)

29	ERX0+	Even pixel Positive LVDS differential data input. Channel 0	
30	ERX1-	Even pixel Negative LVDS differential data input. Channel 1	
31	ERX1+	Even pixel Positive LVDS differential data input. Channel 1	
32	ERX2-	Even pixel Negative LVDS differential data input. Channel 2	
33	ERX2+	Even pixel Positive LVDS differential data input. Channel 2	
34	GND	Ground	
35	ECLK-	Even pixel Negative LVDS differential clock input.	(9)
36	ECLK+	Even pixel Positive LVDS differential clock input.	
37	GND	Ground	
38	ERX3-	Even pixel Negative LVDS differential data input. Channel 3	(9)
39	ERX3+	Even pixel Positive LVDS differential data input. Channel 3	
40	N.C.	No Connection	(1)
41	N.C.	No Connection	
42	LD_EN	Input signal for Local Dimming Enable	(5)(8)
43	SCN_EN	Input signal for Scanning Enable	(6)(8)
44	GND	Ground	
45	GND	Ground	
46	GND	Ground	
47	N.C.	No Connection	(1)
48	VCC	+12V power supply	
49	VCC	+12V power supply	
50	VCC	+12V power supply	
51	VCC	+12V power supply	

CN1 Connector Pin Assignment (LM123S-010-H-TF1-3 (UNE) or equivalent)

1	N.C.	No Connection	(1)
2	N.C.	No Connection	
3	N.C.	No Connection	
4	GND	Ground	
5	N.C.	No Connection	(1)
6	L/R_O	Output signal for Left Right Glasses control	(10)
7	N.C.	No Connection	(1)
8	N.C.	No Connection	
9	N.C.	No Connection	
10	N.C.	No Connection	

Note (1) Reserved for internal use. Please leave it open.

Note (2) LVDS format selection.

L= Connect to GND, H=Connect to +3.3V or Open

SELLVDS	Note
L	JEIDA Format
H or Open	VESA Format

Note (3) 2D/3D mode selection.

L= Connect to GND or Open, H=Connect to +3.3V

2D/3D	Note
L or Open	2D Mode
H	3D Mode

Note (4) Input signal for Left Right eye frame synchronous

$V_{IL}=0\sim 0.7\text{ V}$, $V_{IH}=2.7\sim 3.3\text{ V}$

L/R	Note
L	Right synchronous signal
H	Left synchronous signal

Note (5) Local dimming enable selection.

L= Connect to GND, H=Connect to +3.3V or Open

LD_EN	Note
L	Local Dimming Disable
H	Local Dimming Enable

Note (6) Scanning enable selection.

L= Connect to GND or Open, H=Connect to +3.3V

SCN_EN	Note
L or Open	Scanning Disable
H	Scanning Enable

Note (7) SELLVDS signal pin connected to the LCM side has the following diagram.

R1 in the system side should be less than 1K Ohm. ($R1 < 1K \text{ Ohm}$)

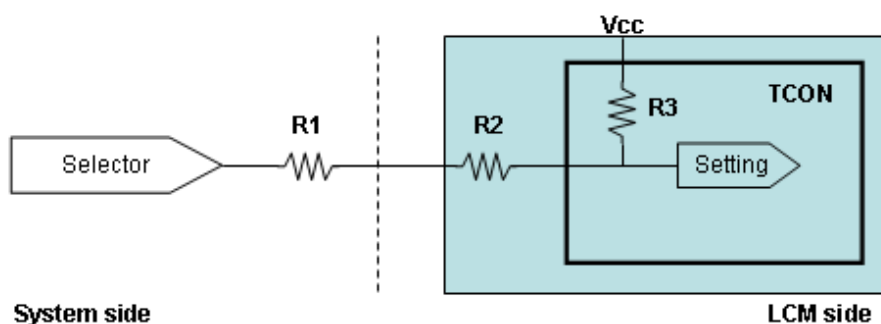

System side
 $R1 < 1K$

Note (8) 2D/3D, L/R, LD_EN and SCN_EN signal pin connected to the LCM side has the following diagram.

R1 in the system side should be less than 1K Ohm. ($R1 < 1K \text{ Ohm}$)

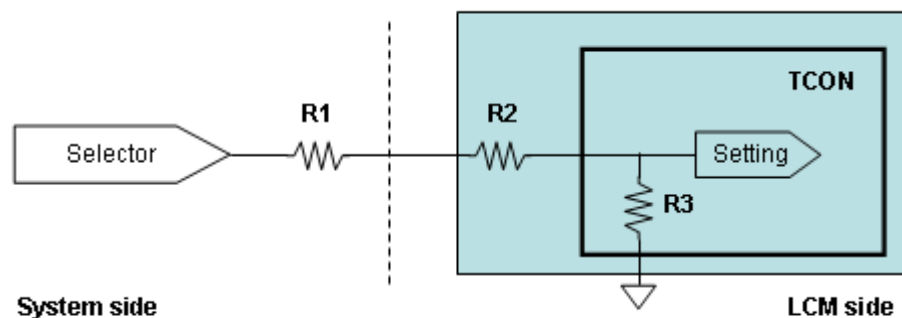

System side: $R1 < 1K$

Note (9) Two pixel data send into the module for every clock cycle. The first pixel of the frame is odd pixel and the second pixel is even pixel.

Note (10) The definition of L/R_O signal as follows

L= 0V , H= +3.3V

L/R_O	Note
L	Right glass turn on
H	Left glass turn on

Note (11) Please reference Appendix A

Note (12) Currently, we only support line alternative format (1st line is left signal), show as the attached block diagram. In the future, we will support other format.

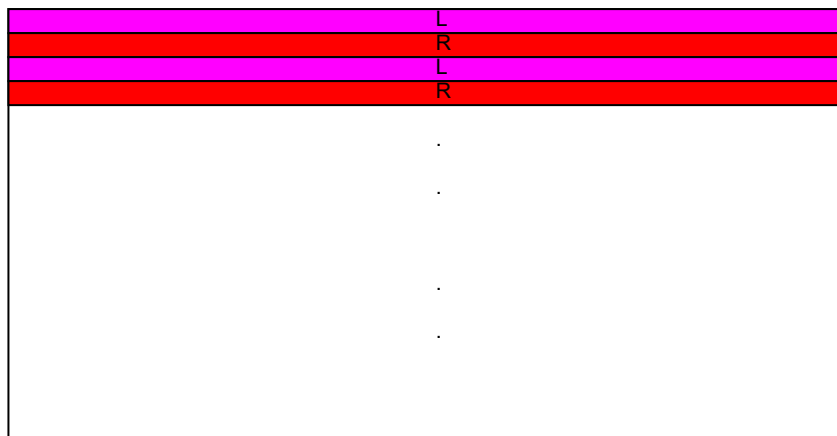

Line alternative format

5.2 BACKLIGHT UNIT

The pin configuration for the housing and the leader wire is shown in the table below.

CN2: 196388-12041-3 (P-TWO)

Pin No	Symbol	Feature
1	VLED+	Positive of LED String
2	VLED+	
3	VLED+	
4	NC	Negative of LED String
5	VLED-	
6	VLED-	
7	VLED-	
8	VLED-	
9	VLED-	
10	VLED-	
11	VLED-	
12	VLED-	

5.3 CONVERTER UNIT

CN1(Header): CI0114M1HRO-LA (CviLux)

Pin No	Symbol	Feature
1	VBL	+24V
2		
3		
4		
5		
6	GND	GND
7		
8		
9		
10		
11	ERR	Normal (GND) Abnormal (Open collector)
12	BLON	BL ON/OFF
13	NC	NC
14	E_PWM	External PWM Control

Notice :

1. If Pin14 is open, E_PWM is 100% duty.

CN3(Header): 196388-12041-3 (P-TWO)

Pin No	Symbol	Feature
1	VLED-	Negative of LED String
2	VLED-	
3	VLED-	
4	VLED-	
5	VLED-	
6	VLED-	
7	VLED-	
8	VLED-	
9	NC	NC
10	VLED+	Positive of LED String
11	VLED+	
12	VLED+	

5.4 BLOCK DIAGRAM OF INTERFACE

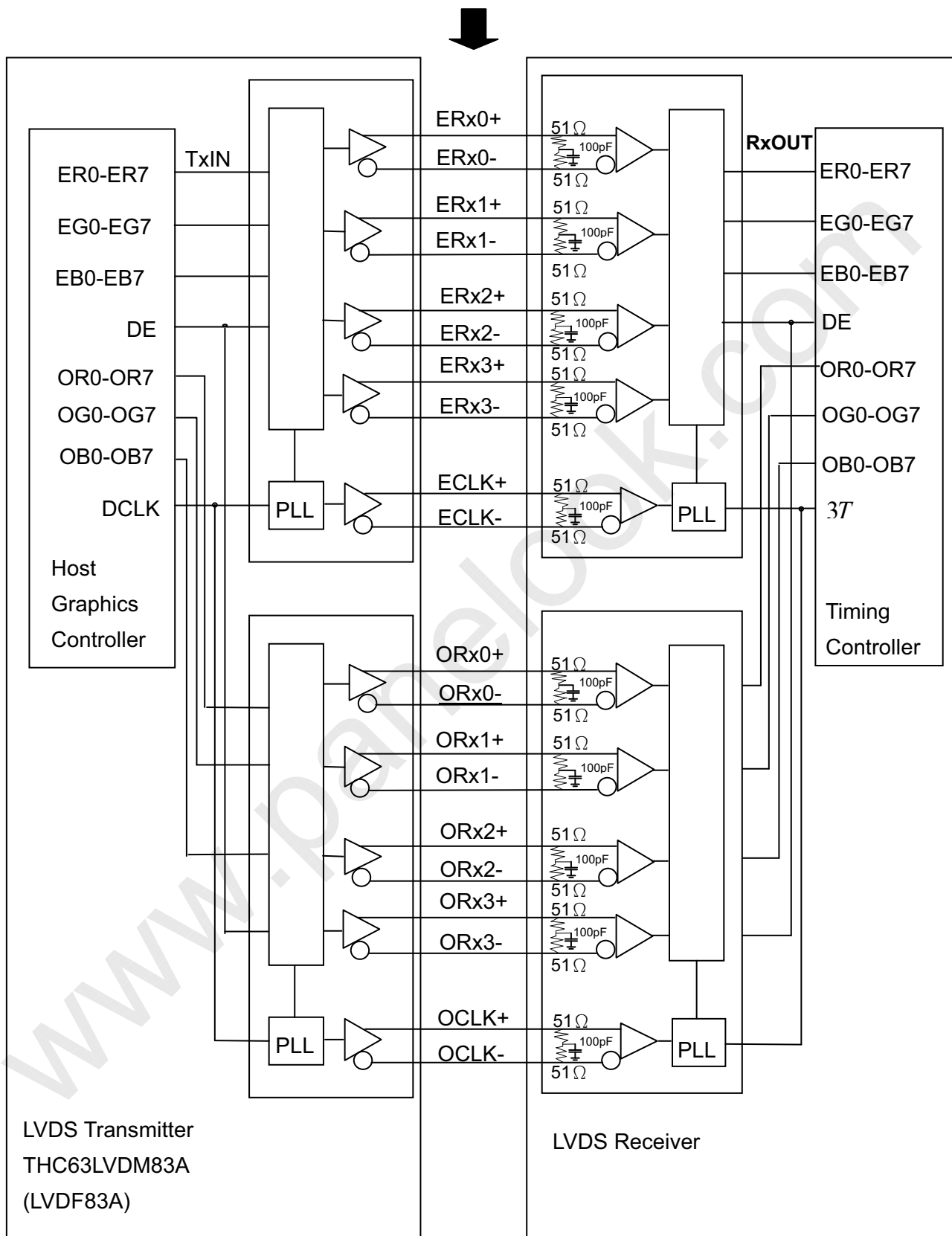

ER0~ER7: Even pixel R data

EG0~EG7: Even pixel G data

EB0~EB7: Even pixel B data

OR0~OR7: Odd pixel R data

OG0~OG7: Odd pixel G data

OB0~OB7: Odd pixel B data

DE: Data enable signal

DCLK: Data clock signal

Notes (1) The system must have the transmitter to drive the module.

Notes (2) LVDS cable impedance shall be 50 ohms per signal line or about 100 ohms per twist-pair line when it is used differentially.

5.5 LVDS INTERFACE

JEIDA Format : SELLVDS = L

VESA Format : SELLVDS = H or Open

VESA LVDS format

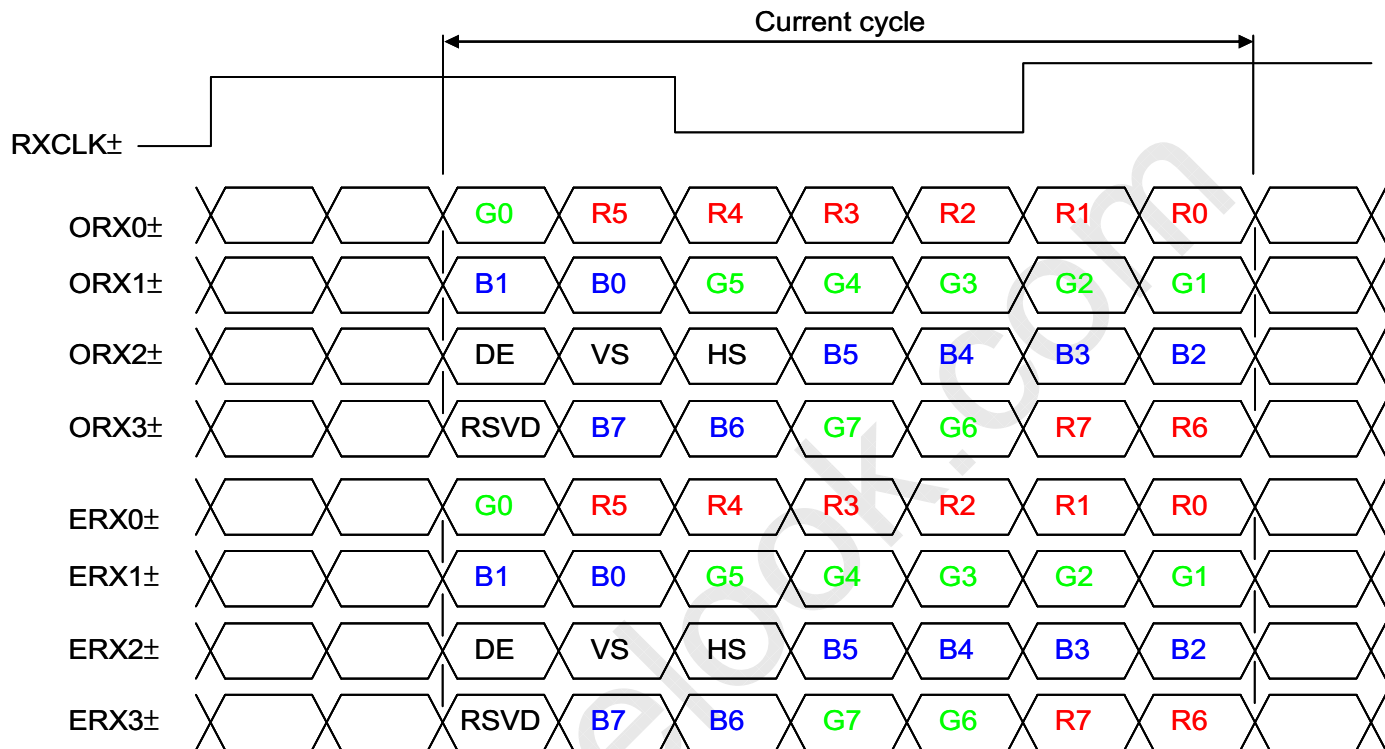

JEDIA LVDS format

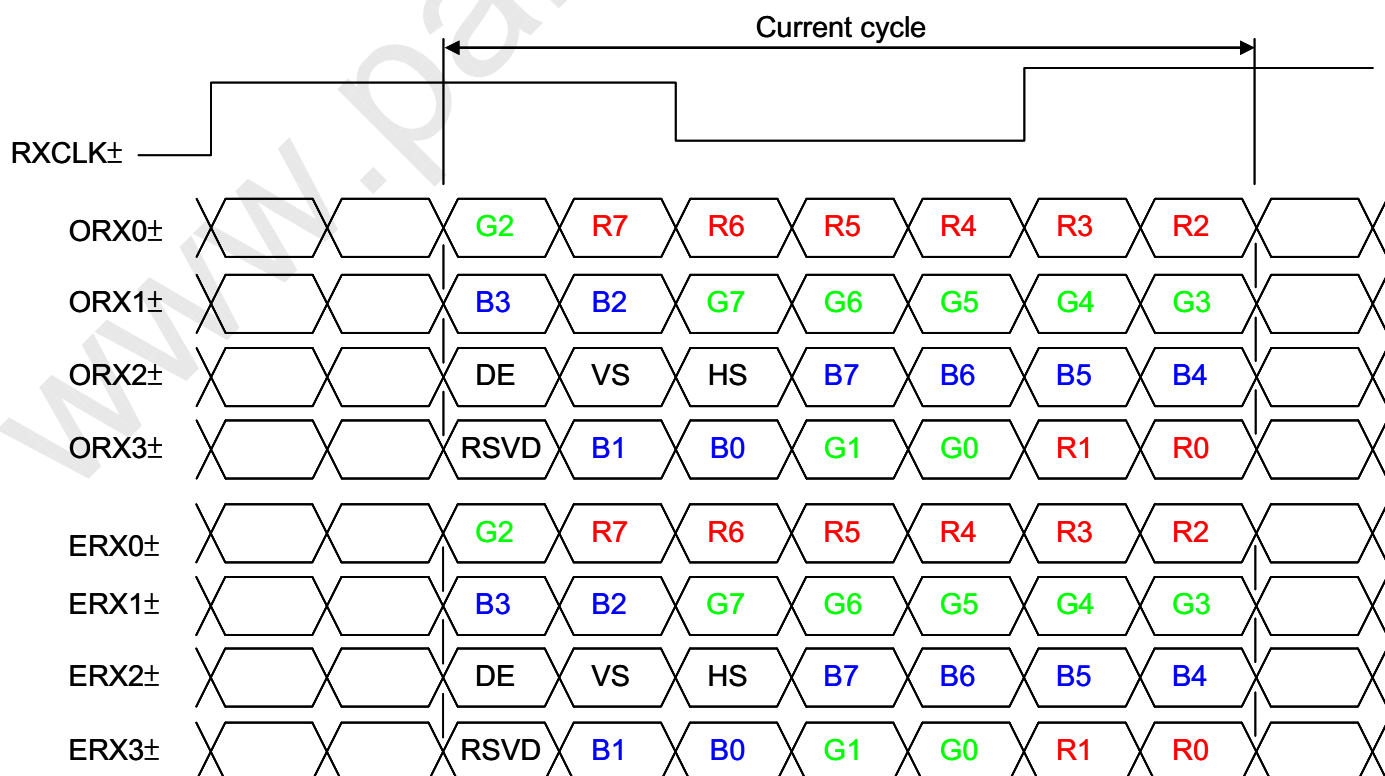

5.6 COLOR DATA INPUT ASSIGNMENT

The brightness of each primary color (red, green and blue) is based on the 8-bit gray scale data input for the color. The higher the binary input, the brighter the color. The table below provides the assignment of the color versus data input.

Color		Data Signal																						
		Red								Green								Blue						
		R7	R6	R5	R4	R3	R2	R1	R0	G7	G6	G5	G4	G3	G2	G1	G0	B7	B6	B5	B4	B3	B2	B1
Basic Colors	Black	0	0	0	0	0	0	0	0	0	0	0	0	0	0	0	0	0	0	0	0	0	0	0
	Red	1	1	1	1	1	1	1	1	0	0	0	0	0	0	0	0	0	0	0	0	0	0	0
	Green	0	0	0	0	0	0	0	0	1	1	1	1	1	1	1	1	0	0	0	0	0	0	0
	Blue	0	0	0	0	0	0	0	0	0	0	0	0	0	0	0	0	1	1	1	1	1	1	1
	Cyan	0	0	0	0	0	0	0	0	1	1	1	1	1	1	1	1	1	1	1	1	1	1	1
	Magenta	1	1	1	1	1	1	1	1	0	0	0	0	0	0	0	0	1	1	1	1	1	1	1
	Yellow	1	1	1	1	1	1	1	1	1	1	1	1	1	1	1	1	0	0	0	0	0	0	0
	White	1	1	1	1	1	1	1	1	1	1	1	1	1	1	1	1	1	1	1	1	1	1	1
Gray Scale Of Red	Red (0) / Dark	0	0	0	0	0	0	0	0	0	0	0	0	0	0	0	0	0	0	0	0	0	0	
	Red (1)	0	0	0	0	0	0	0	1	0	0	0	0	0	0	0	0	0	0	0	0	0	0	
	Red (2)	0	0	0	0	0	0	1	0	0	0	0	0	0	0	0	0	0	0	0	0	0	0	
	⋮	⋮	⋮	⋮	⋮	⋮	⋮	⋮	⋮	⋮	⋮	⋮	⋮	⋮	⋮	⋮	⋮	⋮	⋮	⋮	⋮	⋮	⋮	
	⋮	⋮	⋮	⋮	⋮	⋮	⋮	⋮	⋮	⋮	⋮	⋮	⋮	⋮	⋮	⋮	⋮	⋮	⋮	⋮	⋮	⋮	⋮	
	Red (253)	1	1	1	1	1	1	0	1	0	0	0	0	0	0	0	0	0	0	0	0	0	0	
	Red (254)	1	1	1	1	1	1	1	0	0	0	0	0	0	0	0	0	0	0	0	0	0	0	
	Red (255)	1	1	1	1	1	1	1	1	0	0	0	0	0	0	0	0	0	0	0	0	0	0	
Gray Scale Of Green	Green (0) / Dark	0	0	0	0	0	0	0	0	0	0	0	0	0	0	0	0	0	0	0	0	0	0	
	Green (1)	0	0	0	0	0	0	0	0	0	0	0	0	0	0	1	0	0	0	0	0	0	0	
	Green (2)	0	0	0	0	0	0	0	0	0	0	0	0	0	1	0	0	0	0	0	0	0	0	
	⋮	⋮	⋮	⋮	⋮	⋮	⋮	⋮	⋮	⋮	⋮	⋮	⋮	⋮	⋮	⋮	⋮	⋮	⋮	⋮	⋮	⋮	⋮	
	⋮	⋮	⋮	⋮	⋮	⋮	⋮	⋮	⋮	⋮	⋮	⋮	⋮	⋮	⋮	⋮	⋮	⋮	⋮	⋮	⋮	⋮	⋮	
	Green (253)	0	0	0	0	0	0	0	0	1	1	1	1	1	1	0	1	0	0	0	0	0	0	
	Green (254)	0	0	0	0	0	0	0	0	1	1	1	1	1	1	1	0	0	0	0	0	0	0	
	Green (255)	0	0	0	0	0	0	0	0	1	1	1	1	1	1	1	0	0	0	0	0	0	0	
Gray Scale Of Blue	Blue (0) / Dark	0	0	0	0	0	0	0	0	0	0	0	0	0	0	0	0	0	0	0	0	0	0	
	Blue (1)	0	0	0	0	0	0	0	0	0	0	0	0	0	0	0	0	0	0	0	0	0	1	
	Blue (2)	0	0	0	0	0	0	0	0	0	0	0	0	0	0	0	0	0	0	0	0	0	1	
	⋮	⋮	⋮	⋮	⋮	⋮	⋮	⋮	⋮	⋮	⋮	⋮	⋮	⋮	⋮	⋮	⋮	⋮	⋮	⋮	⋮	⋮	⋮	
	⋮	⋮	⋮	⋮	⋮	⋮	⋮	⋮	⋮	⋮	⋮	⋮	⋮	⋮	⋮	⋮	⋮	⋮	⋮	⋮	⋮	⋮	⋮	
	Blue (253)	0	0	0	0	0	0	0	0	0	0	0	0	0	0	0	1	1	1	1	1	1	0	1
	Blue (254)	0	0	0	0	0	0	0	0	0	0	0	0	0	0	0	1	1	1	1	1	1	1	0
	Blue (255)	0	0	0	0	0	0	0	0	0	0	0	0	0	0	0	1	1	1	1	1	1	1	1

Note (1) 0: Low Level Voltage, 1: High Level Voltage

6. INTERFACE TIMING

6.1 INPUT SIGNAL TIMING SPECIFICATIONS (Ta = 25 ± 2 °C)

The input signal timing specifications are shown as the following table and timing diagram.

Signal	Item	Symbol	Min.	Typ.	Max.	Unit	Note
LVDS Receiver Clock	Frequency	$F_{clk_{in}}$ (=1/TC)	60	74.25	77	MHz	
	Input cycle to cycle jitter	T_{rcj}	-	-	200	ps	(3)
	Spread spectrum modulation range	$F_{clk_{in_mod}}$	$F_{clk_{in}}-2\%$	-	$F_{clk_{in}}+2\%$	MHz	(4)
	Spread spectrum modulation frequency	F_{SSM}	-	-	200	KHz	
LVDS Receiver Data	Receiver Skew Margin	T_{RSKM}	-400	-	400	ps	(5)

6.1.1 Timing spec for Frame Rate = 50Hz

Signal	Item	Symbol	Min.	Typ.	Max.	Unit	Note	
Frame rate	2D mode	F_{r5}	47	50	53	Hz		
	3D mode	F_{r5}	50	50	50	Hz	(7)	
Vertical Active Display Term	2D Mode	Total	T_v	1115	1125	1380	Th	$T_v=T_{vd}+T_{vb}$
		Display	T_{vd}	1080	1080	1080	Th	—
		Blank	T_{vb}	35	45	300	Th	—
	3D Mdoe	Total	T_v	1350			Th	(6), (8)
		Display	T_{vd}	1080			Th	
		Blank	T_{vb}	270			Th	
Horizontal Active Display Term	2D Mode	Total	T_h	1050	1100	1150	T_c	$T_h=T_{hd}+T_{hb}$
		Display	T_{hd}	960	960	960	T_c	—
		Blank	T_{hb}	90	140	190	T_c	—
	3D Mdoe	Total	T_h	1050	1100	1150	T_c	$T_h=T_{hd}+T_{hb}$
		Display	T_{hd}	960	960	960	T_c	—
		Blank	T_{hb}	90	140	190	T_c	—

6.1.2 Timing spec for Frame Rate = 60Hz

Signal	Item	Symbol	Min.	Typ.	Max.	Unit	Note	
Frame rate	2D mode	F_{r6}	57	60	62.5	Hz		
	3D mode	F_{r6}	60	60	60	Hz	(7)	
Vertical Active Display Term	2D Mode	Total	T_v	1115	1125	1380	Th	$T_v=T_{vd}+T_{vb}$
		Display	T_{vd}	1080	1080	1080	Th	—
		Blank	T_{vb}	35	45	300	Th	—
	3D Mdoe	Total	T_v	1125			Th	(6), (8)
		Display	T_{vd}	1080			Th	
		Blank	T_{vb}	45			Th	
Horizontal Active Display Term	2D Mode	Total	T_h	1050	1100	1150	T_c	$T_h=T_{hd}+T_{hb}$
		Display	T_{hd}	960	960	960	T_c	—
		Blank	T_{hb}	90	140	190	T_c	—
	3D Mdoe	Total	T_h	1050	1100	1150	T_c	$T_h=T_{hd}+T_{hb}$
		Display	T_{hd}	960	960	960	T_c	—
		Blank	T_{hb}	90	140	190	T_c	—

Note Please make sure the range of pixel clock has follow the below equation:

$$F_{clk(\max)} \geq F_{r6} \times T_v \times T_h$$

$$F_{r5} \times T_v \times T_h \geq F_{clk(\min)}$$

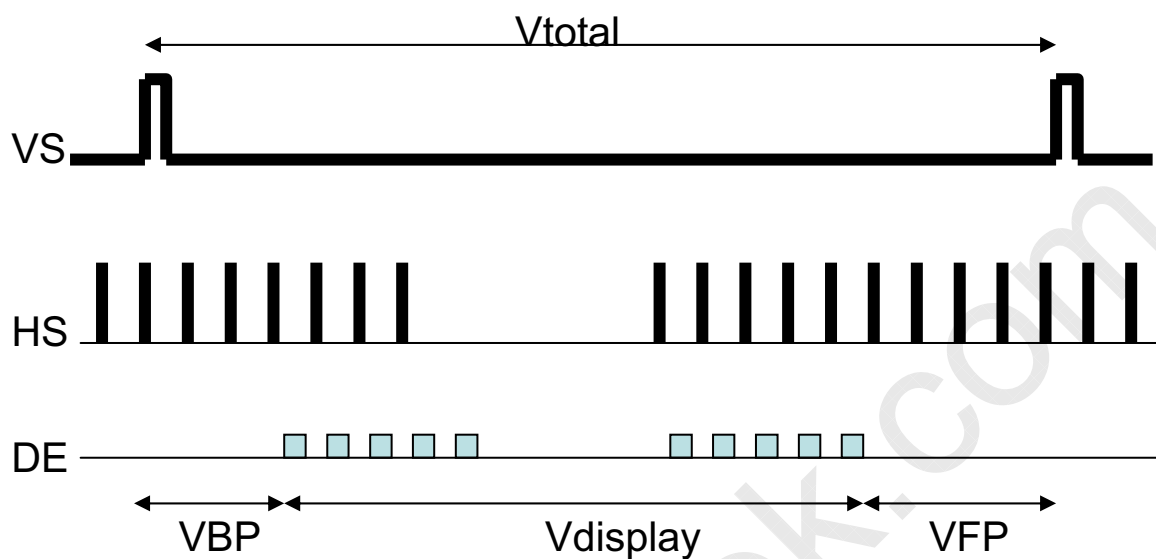
INPUT SIGNAL TIMING DIAGRAM

- VBP max : 150 line

Suggest $VBP = VFP = \frac{1}{2} * (Vtotal - Vdisplay)$

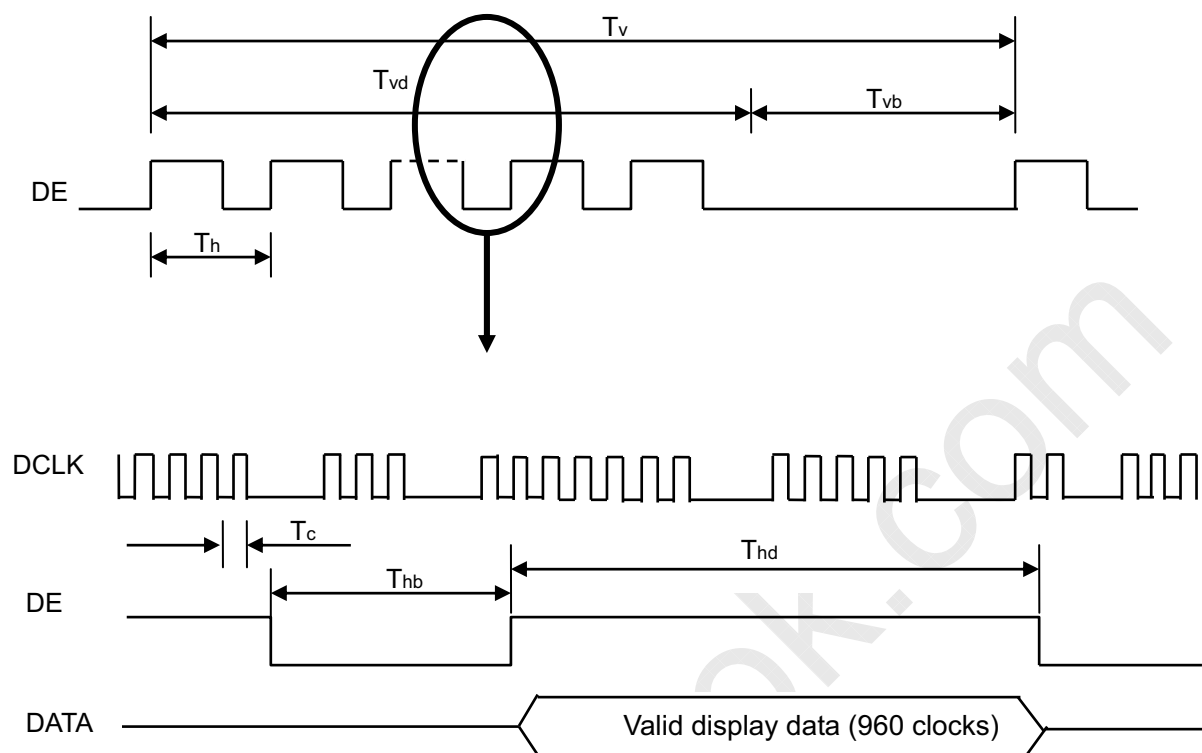
DE timing

Note (3) The input clock cycle-to-cycle jitter is defined as below figures. $Trcl = |T_1 - T_2|$

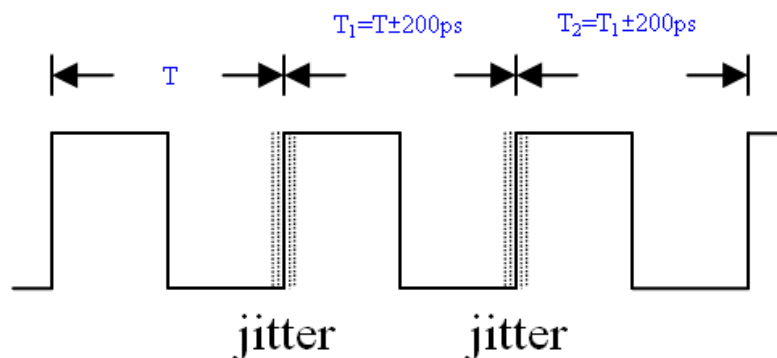

Note (4) The SSCG (Spread spectrum clock generator) is defined as below figures.

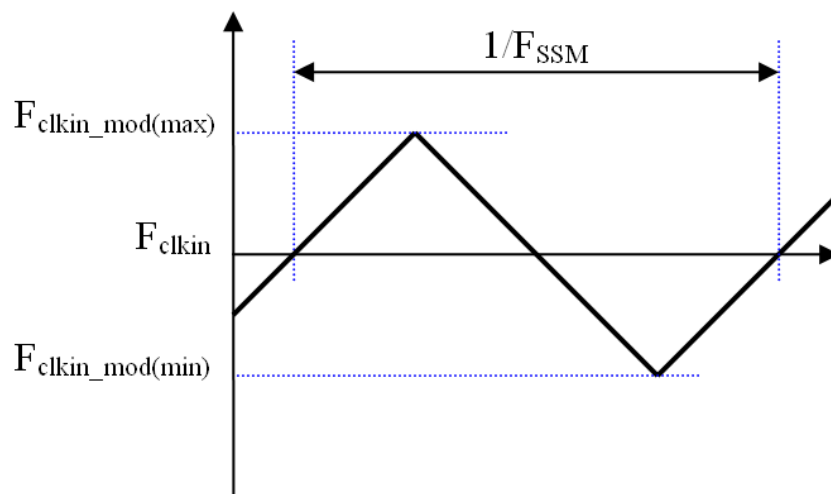

Note (5) LVDS receiver skew margin is defined and shown as below.

LVDS RECEIVER INTERFACE TIMING DIAGRAM

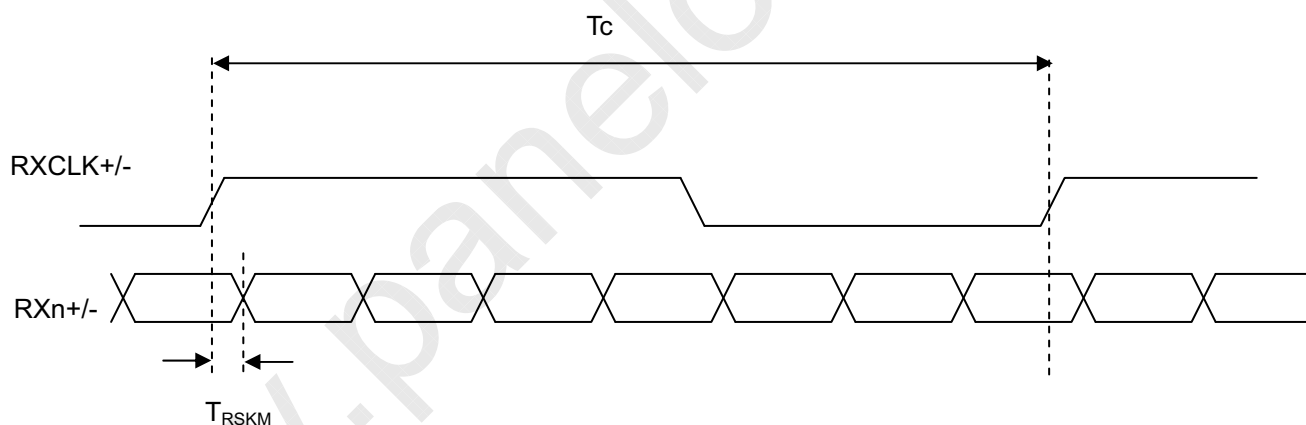

Note (6) Please fix the Vertical timing (Vertical Total = 1350 / Display = 1080 / Blank = 270) in 50Hz 3D mode
and Vertical timing (Vertical Total = 1125 / Display = 1080 / Blank = 45) in 60Hz 3D mode

Note (7) In 3D mode, the set up Fr5 and Fr6 in Typ. ± 3 HZ .In order to ensure that the electric function performance to avoid no display symptom.(Except picture quality symptom.)

Note (8) In 3D mode, the set up Tv and Tvb in Typ. ± 30 .In order to ensure that the electric function performance to avoid no display symptom.(Except picture quality symptom.)

6.2 POWER ON/OFF SEQUENCE
6.2.1 POWER ON/OFF SEQUENCE ($T_a = 25 \pm 2 \text{ }^\circ\text{C}$)

To prevent a latch-up or DC operation of LCD module, the power on/off sequence should be as the diagram below.

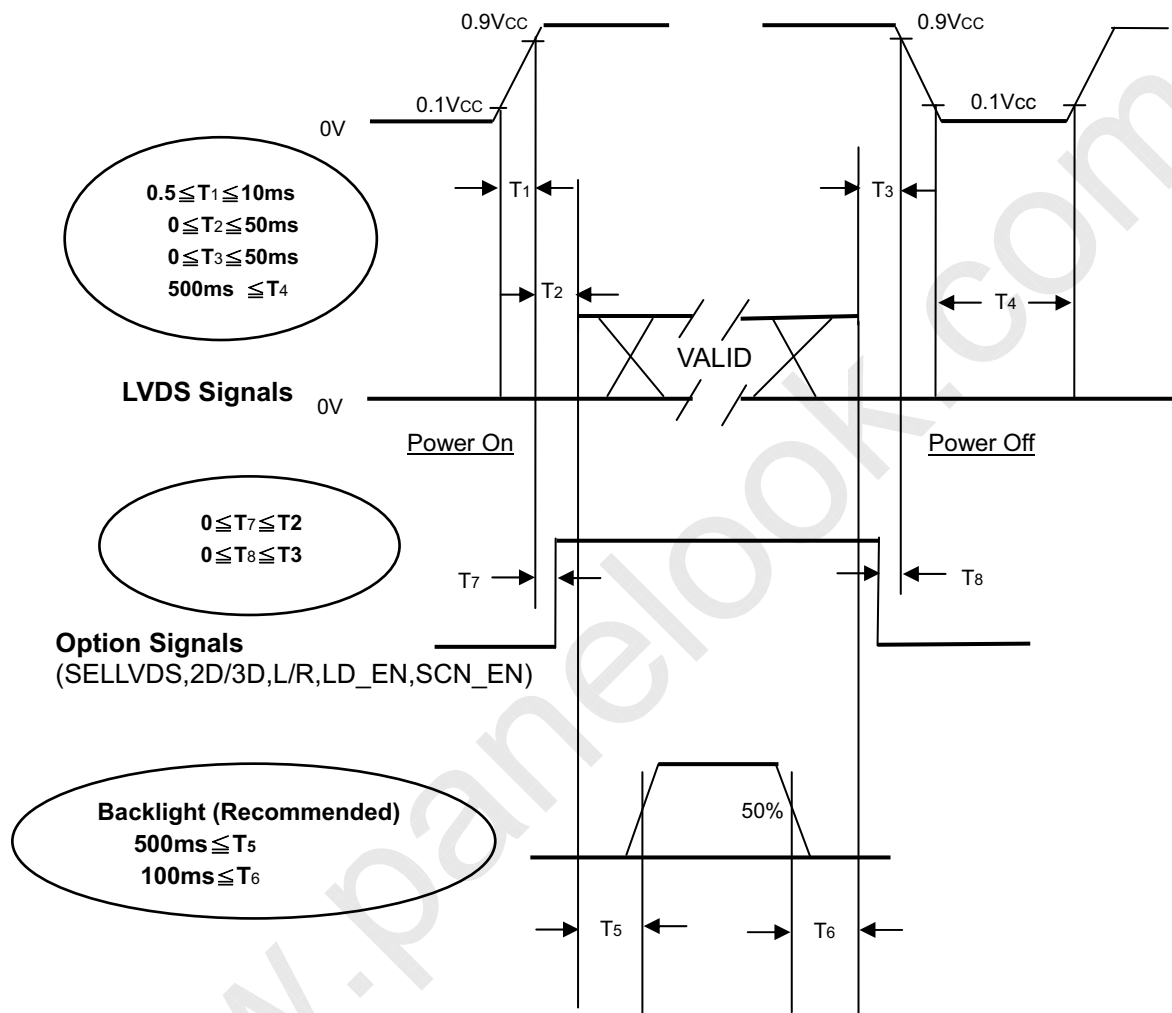
Power ON/OFF Sequence

6.2.1 (2D/3D MODE CHANGE SIGNAL SEQUENCE WITHOUT VCC TURN OFF AND TURN ON)

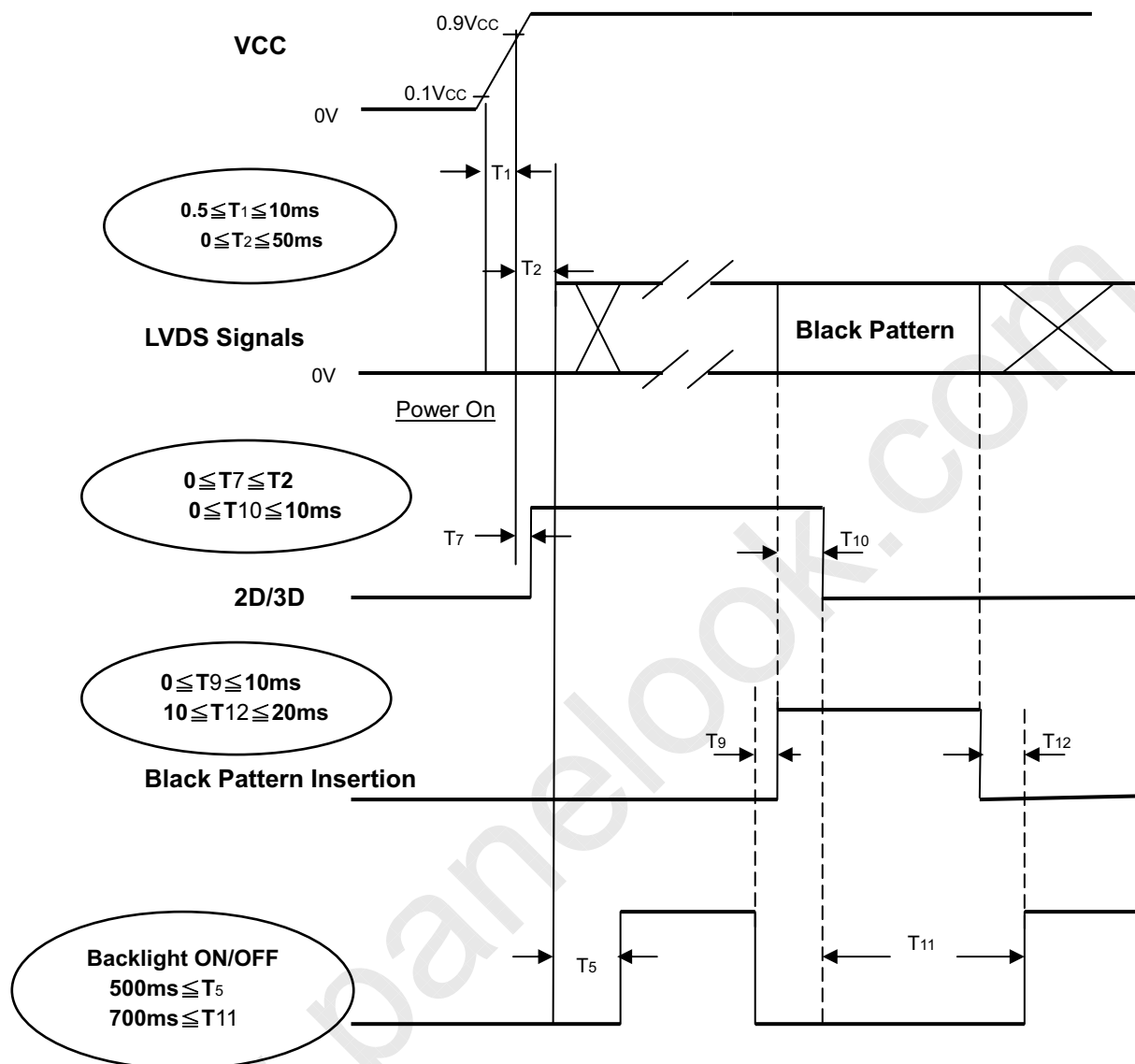

Note (1) The supply voltage of the external system for the module input should follow the definition of V_{cc}.

Note (2) Apply the LED voltage within the LCD operation range. When the backlight turns on before the LCD operation or the LCD turns off before the backlight turns off, the display may momentarily become abnormal screen.

Note (3) In case of V_{cc} is in off level, please keep the level of input signals on the low or high impedance. If $T_2 < 0$, that maybe cause electrical overstress failure.

Note (4) T₄ should be measured after the module has been fully discharged between power off and on period.

Note (5) Interface signal shall not be kept at high impedance when the power is on.

Note (6) When 2D/3D mode is changed, TCON will insert black pattern internally. During black insertion, TCON would load required optical table and TCON parameter setting. The black insertion time should be longer than 650ms because TCON must recognize 2D or 3D format and set the correct parameter.

Note (7) 2D/3D switching time should be larger than 500ms.

7. OPTICAL CHARACTERISTICS

7.1 TEST CONDITIONS

Item	Symbol	Value	Unit
Ambient Temperature	Ta	25±2	°C
Ambient Humidity	Ha	50±10	%RH
Supply Voltage	VCC	12	V
Input Signal	According to typical value in "3. ELECTRICAL CHARACTERISTICS"		
LED Current	IL	145±4	mA
Vertical Frame Rate	Fr	120	Hz

The LCD module should be stabilized at given temperature for 1 hour to avoid abrupt temperature change during measuring. In order to stabilize the luminance, the measurement should be executed after lighting backlight for 1 hour in a windless room.

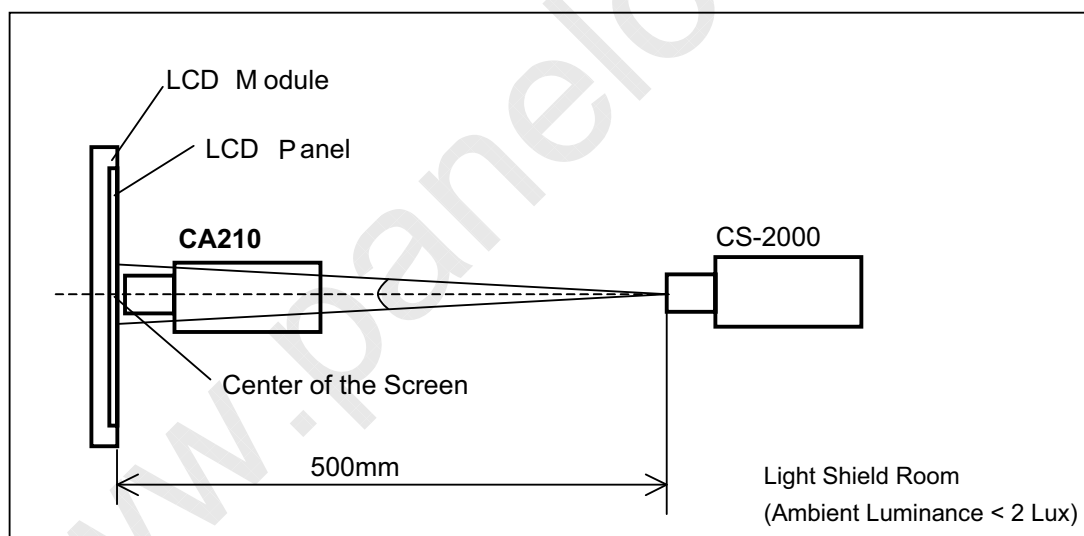

7.2 OPTICAL SPECIFICATIONS

The relative measurement methods of optical characteristics are shown in 7.2. The following items should be measured under the test conditions described in 7.1 and stable environment shown in 7.1.

Item		Symbol	Condition	Min.	Typ.	Max.	Unit	Note	
Contrast Ratio		CR	$\theta_x=0^\circ, \theta_y=0^\circ$ Viewing angle at normal direction	3500	5000		-	(2)	
Response Time (VA)		Gray to gray			8.5		ms	(3)	
Center Luminance of White		L _c		2D	280	350		cd/m ²	(4)
				3D		55		cd/m ²	(8)
White Variation		δW				1.3	-	(6)	
Cross Talk		CT		2D			4	%	(5)
				3D-W	-	4	-	%	(8)
				3D-D	-	11	-	%	(8)
Color Chromaticity	Red	R _x		$\theta_x=0^\circ, \theta_y=0^\circ$ Viewing angle at normal direction	Typ. -0.03	Typ. +0.03			-
		R _y							-
	Green	G _x	-						
		G _y	-						
	Blue	B _x	-						
		B _y	-						
	White	W _x	-						
		W _y	-						
	Correlated color temperature								-
Color Gamut	C.G.	-	68	-	%	NTSC			
Viewing Angle	Horizontal	θ_{x+}	CR \geq 20	80	88	-	Deg.	(1)	
		θ_{x-}		80	88	-			
	Vertical	θ_{y+}		80	88	-			
		θ_{y-}		80	88	-			
Transmission direction of the up polarizer		Φ_{up}	-	-	90	-	Deg.	(7)	

Note (1) Definition of Viewing Angle (θ_x , θ_y) :

Viewing angles are measured by Autronic Conoscope Cono-80

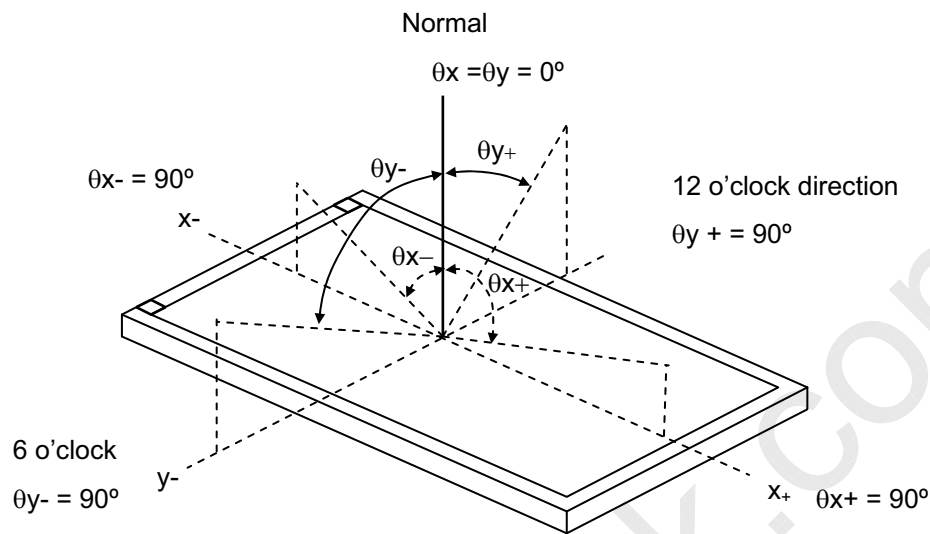

Note (2) Definition of Contrast Ratio (CR) :

The contrast ratio can be calculated by the following expression.

$$\text{Contrast Ratio (CR)} = \frac{\text{Surface Luminance of L255}}{\text{Surface Luminance of L0}}$$

L255: Luminance of gray level 255

L 0: Luminance of gray level 0

CR = CR (5), where CR (X) is corresponding to the Contrast Ratio of the point X at the figure in Note (6).

Note (3) Definition of Gray-to-Gray Switching Time:

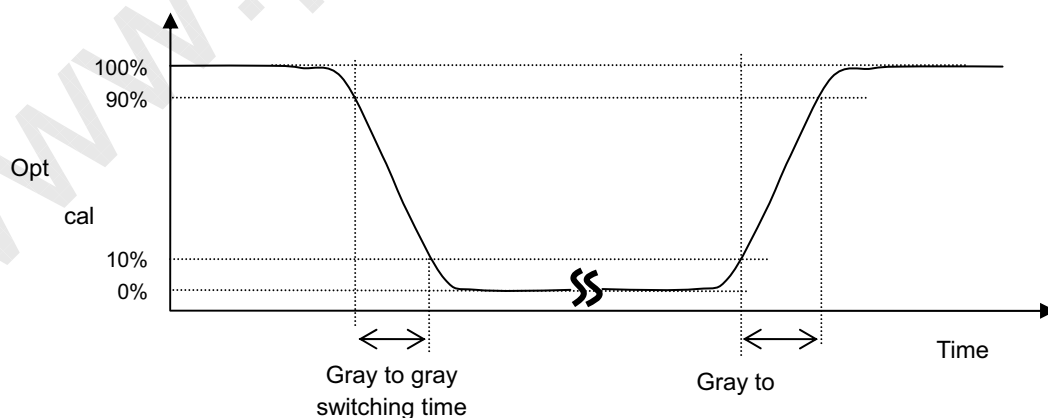

The driving signal means the signal of gray level gray level (0, 63, 127, 191, 255)..Gray to gray average.
 Gray to gray average time means the average switching time of gray level (0, 63, 127, 191, 255)..Gray to gray average

Note (4) Definition of Luminance of White (LC):

Measure the luminance of gray level 255 at center point and 5 points

$L_C = L(5)$, where $L(X)$ is corresponding to the luminance of the point X at the figure in Note (6).

Note (5) Definition of Cross Talk (CT):

$$CT = |Y_B - Y_A| / Y_A \times 100 (\%)$$

Y_A = Luminance of measured location without gray level 255 pattern (cd/m^2)

Y_B = Luminance of measured location with gray level 255 pattern (cd/m^2)

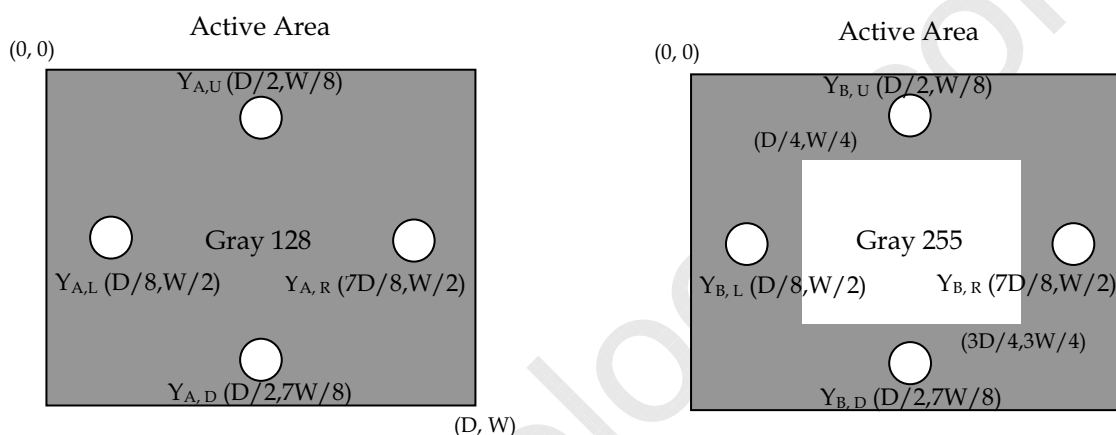

Note (6) Definition of White Variation (δW):

Measure the luminance of gray level 255 at 5 points

$$\delta W = \text{Maximum} [L(1), L(2), L(3), L(4), L(5)] / \text{Minimum} [L(1), L(2), L(3), L(4), L(5)]$$

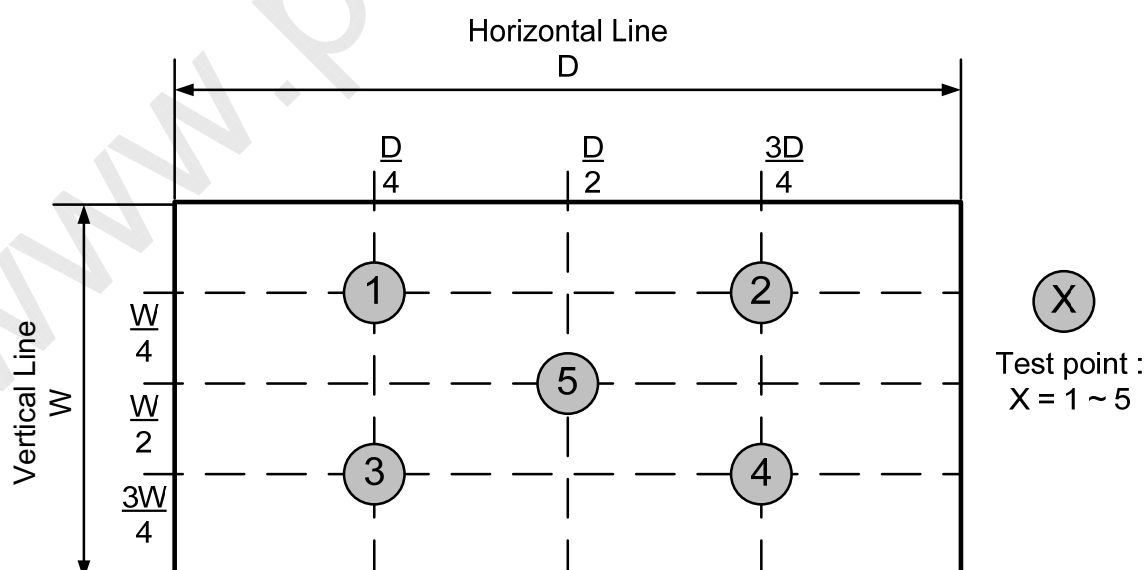

Note (7) This is a reference for designing the shutter glasses of 3D application. (VA)

Definition of the transmission direction of the up polarizer:

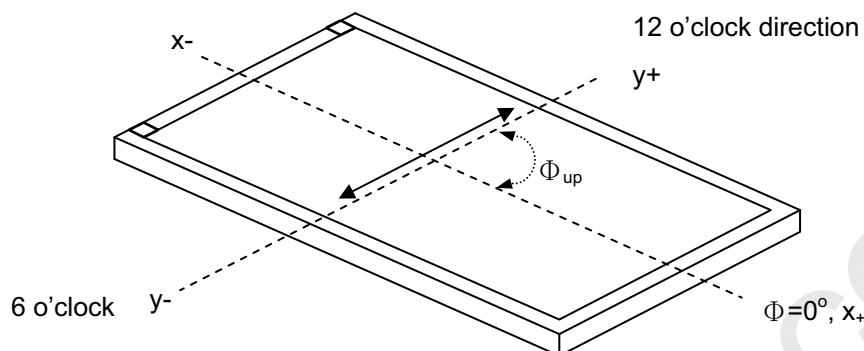

The transmission axis of the front polarizer of the shutter glasses should be parallel to this panel transmission direction to get a maximum 3D mode luminance.

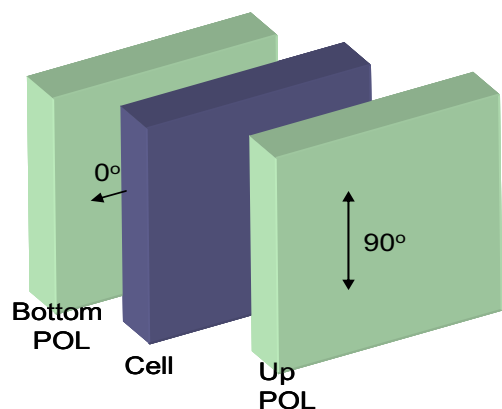

LCD module

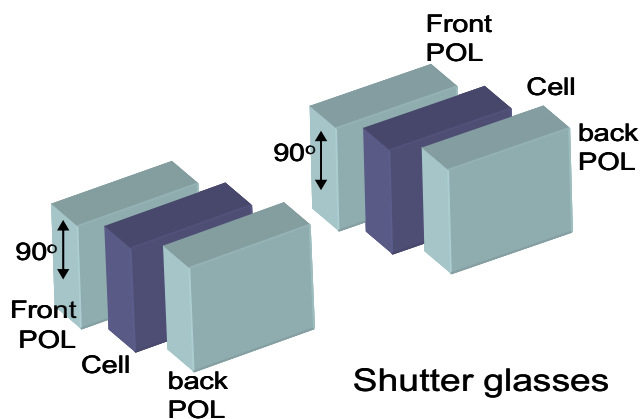





Shutter glasses

Note (8) Definition of the 3D mode performance (measured under 3D mode, use CMI's shutter glass):

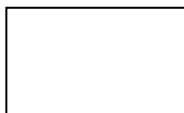
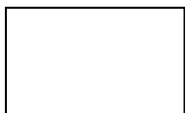
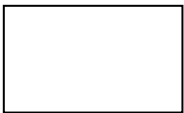
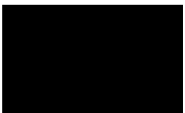
a. Test pattern

Left eye image and right eye image are displayed alternated

		WW Left eye image: W255; Right eye image: W255
		WB Left eye image: W255; Right eye image: W0
		BW Left eye image: W0; Right eye image: W255
		BB Left eye image: W0; Right eye image: W0

b. Measurement setup

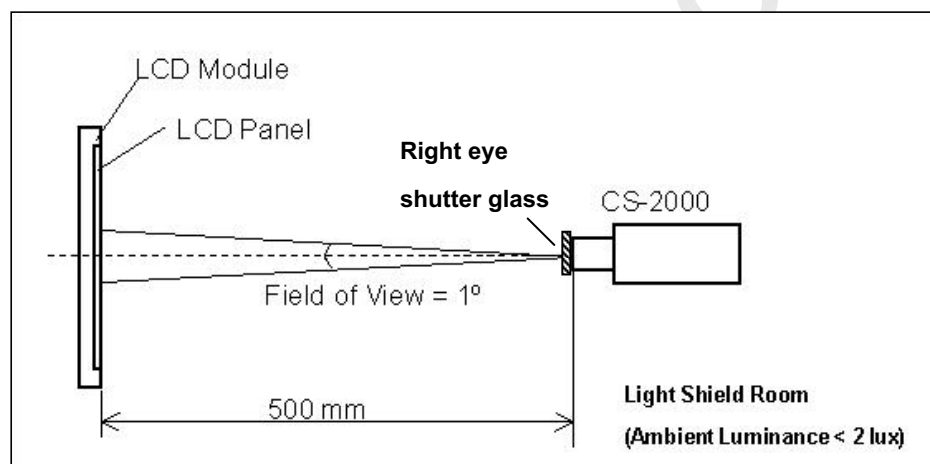

Shutter glasses are well controlled under suitable timing, and measure the luminance of the center point of the panel through the right eye glass. The transmittance of the glass should be larger than 40.0% under 3D mode operation.

The luminance of the test pattern "WW", denoted $L(WW)$; the luminance of the test pattern "WB", denoted $L(WB)$; the luminance of the test pattern "BW", denoted $L(BW)$; the luminance of the test pattern "BB", denoted $L(BB)$

c. Definition of the Center Luminance of White, $L_c(3D)$: $L(WW)$

d. Definition of the 3D mode white crosstalk, $CT(3D-W)$: $CT(3D-W) \equiv \frac{L(WB) - L(BB)}{L(WW) - L(BB)}$

e. Definition of the 3D mode dark crosstalk, $CT(3D-D)$: $CT(3D-D) \equiv \frac{L(WW) - L(BW)}{L(WW) - L(BB)}$

8. PRECAUTIONS

8.1 ASSEMBLY AND HANDLING PRECAUTIONS

- [1] Do not apply rough force such as bending or twisting to the module during assembly.
- [2] It is recommended to assemble or to install a module into the user's system in clean working areas. The dust and oil may cause electrical short or worsen the polarizer.
- [3] Do not apply pressure or impulse to the module to prevent the damage of LCD panel and Backlight.
- [4] Always follow the correct power-on sequence when the LCD module is turned on. This can prevent the damage and latch-up of the CMIS LSI chips.
- [5] Bezel of Set can not press or touch the panel surface. It will make light leakage or scrape.
- [6] Do not plug in or pull out the I/F connector while the module is in operation.
- [7] Do not disassemble the module.
- [8] Use a soft dry cloth without chemicals for cleaning, because the surface of polarizer is very soft and easily scratched.
- [9] Moisture can easily penetrate into LCD module and may cause the damage during operation.
- [10] When storing modules as spares for a long time, the following precaution is necessary.
 - [10.1] Do not leave the module in high temperature, and high humidity for a long time. It is highly recommended to store the module with temperature from 0 to 35°C at normal humidity without condensation.
 - [10.2] The module shall be stored in dark place. Do not store the TFT-LCD module in direct sunlight or fluorescent light.
- [11] When ambient temperature is lower than 10°C, the display quality might be reduced. For example, the response time will become slow, and the starting voltage of CCFL will be higher than that of room temperature.

8.2 SAFETY PRECAUTIONS

- [1] The startup voltage of a Backlight is approximately 1000 Volts. It may cause an electrical shock while assembling with the converter. Do not disassemble the module or insert anything into the Backlight unit.
- [2] If the liquid crystal material leaks from the panel, it should be kept away from the eyes or mouth. In case of contact with hands, skin or clothes, it has to be washed away thoroughly with soap.
- [3] After the module's end of life, it is not harmful in case of normal operation and storage.

9. DEFINITION OF LABELS
9.1 CMI MODULE LABEL

The barcode nameplate is pasted on each module as illustration, and its definitions are as following explanation.

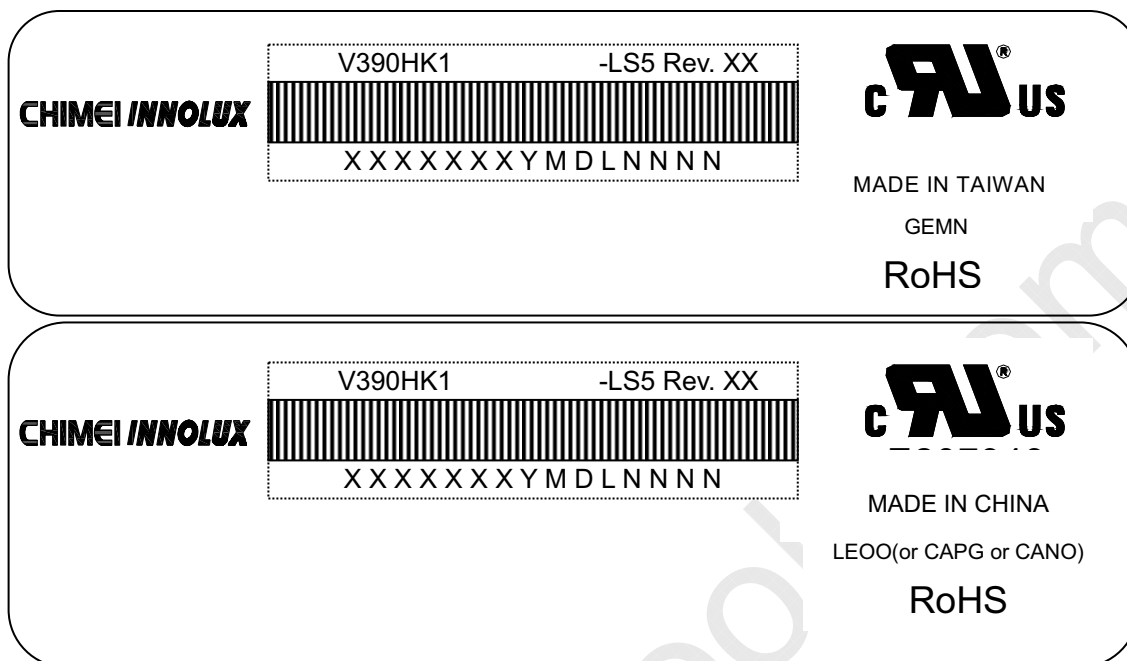

- (a) Model Name: V390HK1-LS5
 (b) Revision: Rev. XX, for example: A0, A1... B1, B2... or C1, C2...etc.
 (c) Serial ID: XXXXXXXYMDLNNNN

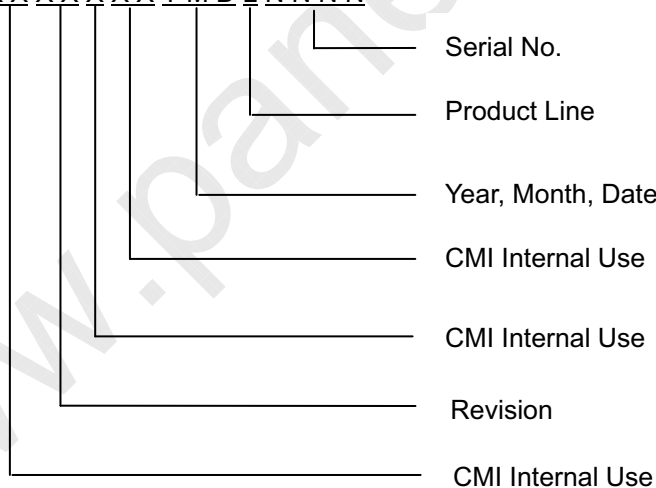

Serial ID includes the information as below:

- (a) **Manufactured Date:** Year: 0~9, for 2010~2019
 Month: 1~9, A~C, for Jan. ~ Dec.
 Day: 1~9, A~Y, for 1st to 31st, exclude I, O, and U.
- (b) **Revision Code:** Cover all the change
- (c) **Serial No.:** Manufacturing sequence of product
- (d) **Product Line:** 1 -> Line1, 2 -> Line 2, ...etc.

10. PACKAGING

10.1 PACKAGING SPECIFICATIONS

- (1) 7 LCD TV modules / 1 Box
- (2) Box dimensions : 954(L)x378(W)x602(H)mm
- (3) Weight : Approx. 57Kg(7 modules per carton)

10.2 PACKAGING METHOD

Figures 10-1 and 10-2 are the packing method

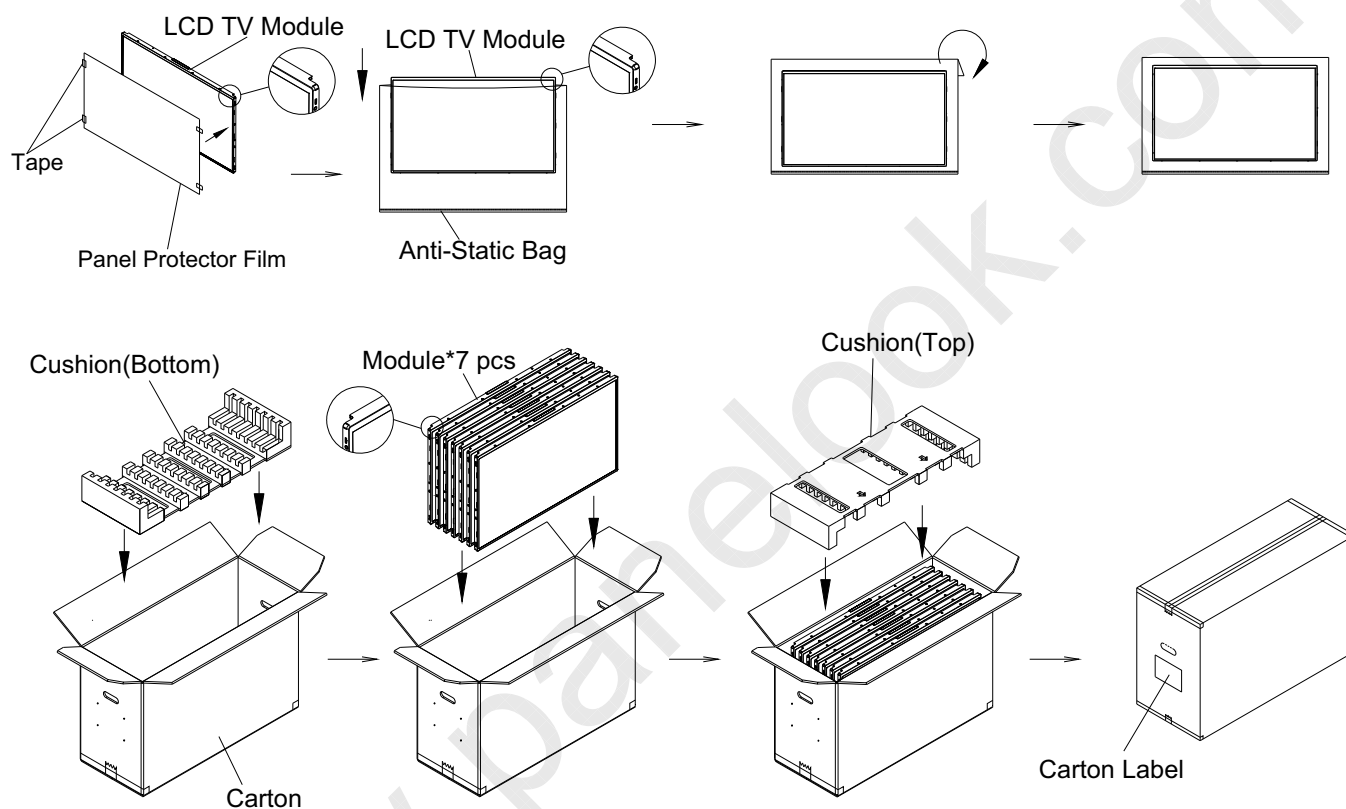
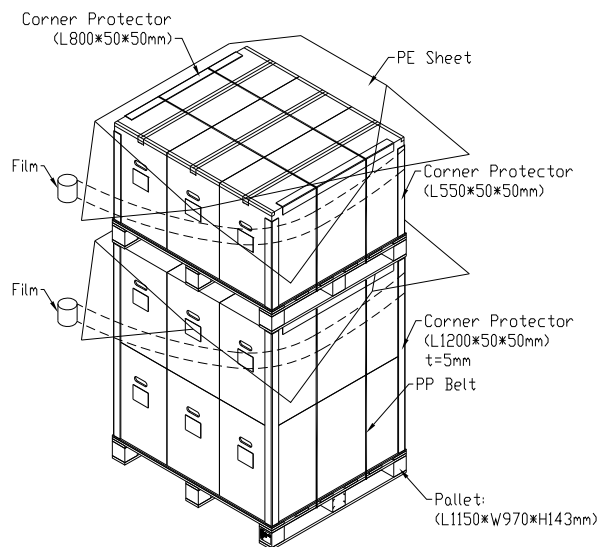

Figure 10-1 packing method

Sea / Land Transportation (40ft HQ / 40ft Container)



Air Transportation

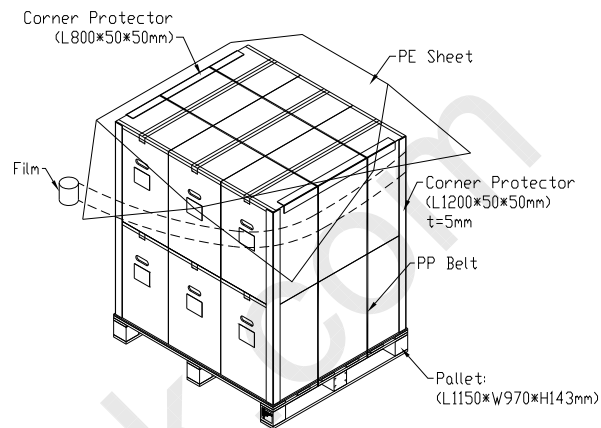
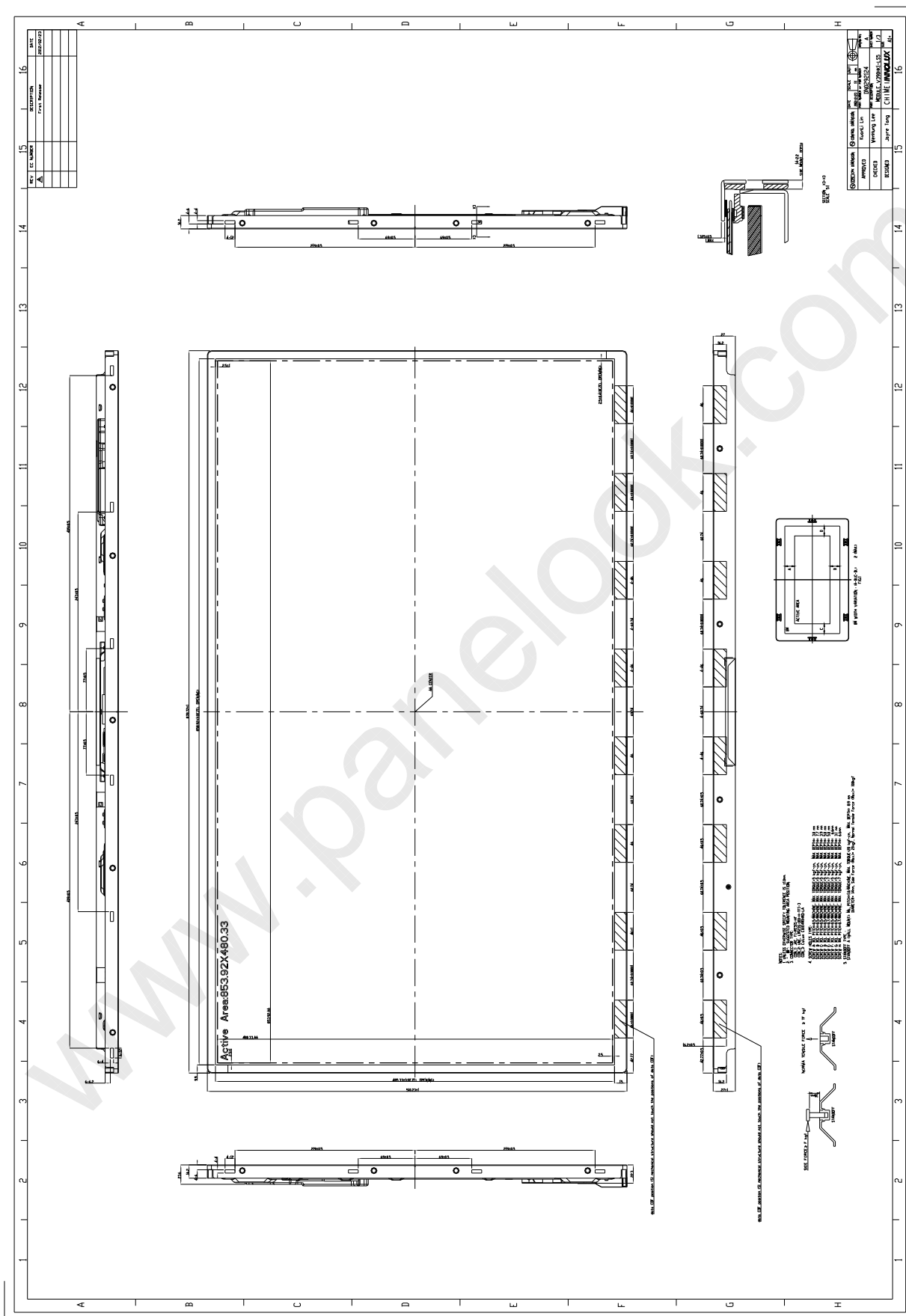
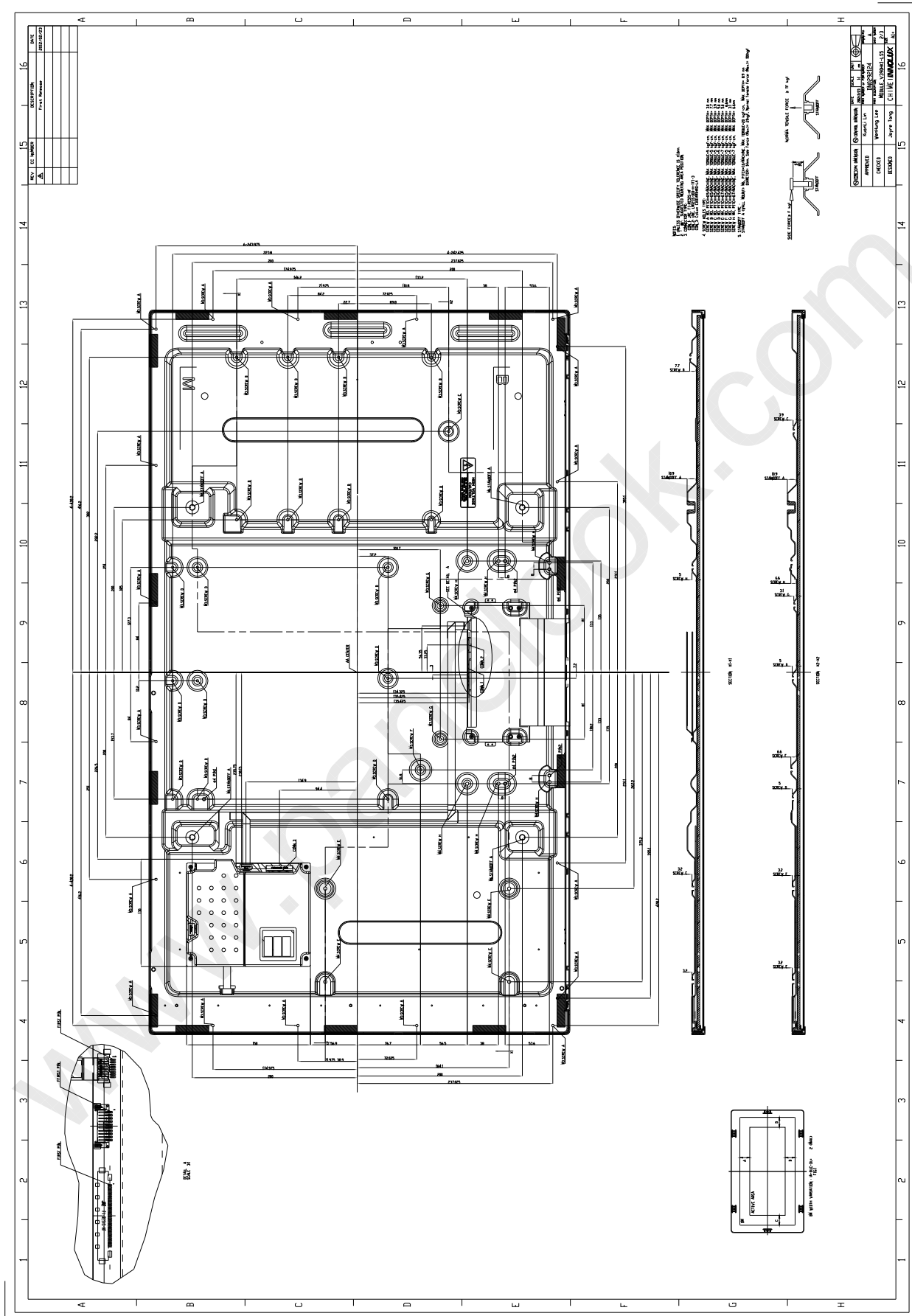
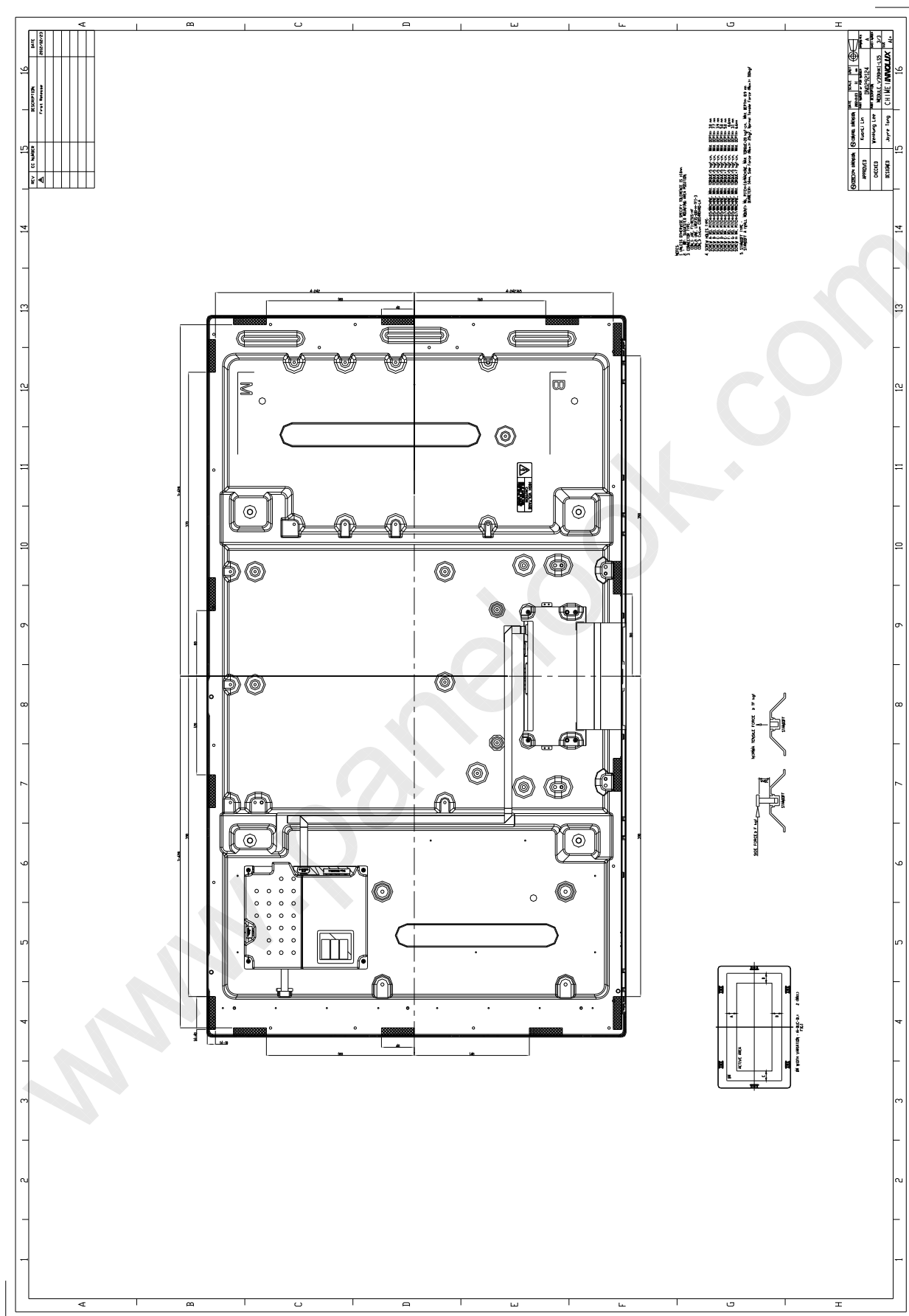

Figure 10-2 packing method

11. MECHANICAL CHARACTERISTIC







APPENDIX A

LOCAL DIMMING DEMO FUCTION

A.1 I2C ADDRESS AND WRITE COMMAND

Device address : 0xe0

Register address: 0x65

Command data: 0x16 0x00 0x00 0x00 0x00 0x00: Local Dimming demo mode OFF (Note 1)

0x16 0x00 0x00 0x00 0x00 0x01 : Local Dimming demo mode ON (Demo in right half screen) (Note 2)

Preamble data: 0x26 0x38

I2C data:

	Device Address		Preamble data		Preamble data	
START	11100000 (0xE0)	ACK	00100110 (0x26)	ACK	00111000 (0x38)	ACK

Register Address		Command Data		Command Data	
01100101 (0x65)	ACK	00010110 (0x16)	ACK	00000000 (0x00)	ACK

Command Data		Command Data		Command Data	
	ACK	00000000 (0x00)	ACK	00000000 (0x00)	ACK

Command Data	
00000001 (0x01)	STOP

Note 1: Local Dimming demo OFF



Note 2: Local Dimming demo ON



A.2 I2C TIMING

Symbol	Parameter	Min.	Max.	Unit
t_{SU-STA}	Start setup time	250	-	ns
t_{HD-STA}	Start hold time	250	-	ns
t_{SU-DAT}	Data setup time	80	-	ns
t_{HD-DAT}	Data hold time	0	-	ns
t_{SU-STO}	Stop setup time	250	-	ns
t_{BUF}	Time between Stop condition and next Start condition	500	-	ns

