

- Tentative Specification
- Preliminary Specification
- Approval Specification

MODEL NO.: V420DK1

SUFFIX: LS1

REV.: C1

Customer:	
APPROVED BY	SIGNATURE
Name / Title _____	
Note _____	
Please return 1 copy for your confirmation with your signature and comments.	

Approved By	Checked By	Prepared By
Chao-Chun Chung	YP Lee	Jim Ho

CONTENTS

CONTENTS..... 2

REVISION HISTORY..... 4

1. GENERAL DESCRIPTION..... 5

 1.1 OVERVIEW 5

 1.2 FEATURES 5

 1.3 APPLICATION..... 5

 1.4 GENERAL SPECIFICATIONS 5

 1.5 MECHANICAL SPECIFICATIONS..... 6

2. ABSOLUTE MAXIMUM RATINGS 7

 2.1 ABSOLUTE RATINGS OF ENVIRONMENT 7

 2.2 PACKAGE STORAGE..... 8

 2.3 ELECTRICAL ABSOLUTE RATINGS 8

 2.3.1 TFT LCD MODULE 8

 2.3.2 BACKLIGHT CONVERTER UNIT..... 8

3. ELECTRICAL CHARACTERISTICS 9

 3.1 TFT LCD MODULE 9

 3.2 BACKLIGHT UNIT..... 12

 3.2.1 CONVERTER CHARACTERISTICS 12

 3.2.2 CONVERTER INTERFACE CHARACTERISTICS 14

4. BLOCK DIAGRAM OF INTERFACE 16

 4.1 TFT LCD MODULE 16

5. INPUT TERMINAL PIN ASSIGNMENT 17

 5.1 TFT LCD MODULE 17

 5.2 BACKLIGHT UNIT..... 23

 5.3 CONVERTER UNIT 24

 5.4 LVDS INTERFACE 25

 5.5 COLOR DATA INPUT ASSIGNMENT 26

6. INTERFACE TIMING..... 27

 6.1 INPUT SIGNAL TIMING SPECIFICATIONS 27

 6.1.1 Input Timing Spec for FHD, Frame Rate = 50Hz 27

6.1.2 Input Timing Spec for FHD, Frame Rate = 60Hz	28
6.1.3 Input Timing Spec for FHD, Frame Rate = 100Hz	28
6.1.4 Input Timing Spec for FHD, Frame Rate = 120Hz	29
6.1.5 Input Timing spec for QFHD, Frame Rate = 24Hz.....	30
6.1.6 Input Timing spec for QFHD, Frame Rate = 30Hz.....	30
6.2 POWER ON/OFF SEQUENCE	33
7. OPTICAL CHARACTERISTICS	34
7.1 TEST CONDITIONS.....	34
7.2 OPTICAL SPECIFICATIONS	35
8. PRECAUTIONS.....	40
8.1 ASSEMBLY AND HANDLING PRECAUTIONS	40
8.2 SAFETY PRECAUTIONS	40
8.3 SAFETY STANDARDS	40
9. DEFINITION OF LABELS.....	41
9.1 INX MODULE LABEL.....	41
9.2 CARTON LABEL	42
10. PACKAGING.....	43
10.1 PACKAGING SPECIFICATIONS	43
10.2 PACKAGING METHOD.....	43
10.3 UN-PACKAGING METHOD	45
11. MECHANICAL CHARACTERISTIC.....	46

REVISION HISTORY

Version	Date	Page (New)	Section	Description
Ver. 2.0	May.07, 2013	All	All	The approval specification was first issued.

1. GENERAL DESCRIPTION

1.1 OVERVIEW

V420DK1-LS1 is a 42" TFT Liquid Crystal Display module with LED Backlight unit and 4ch-LVDS interface.

This module supports 3840 x 2160 Quad Full HDTV format and can display true 1.07G colors (8-bit+FRC).

The driving board module for backlight is built-in.

1.2 FEATURES

- High brightness 350 nits
- High contrast ratio 5000:1
- Fast response time Gray to Gray typical : 6.5 ms
- High color saturation NTSC 72%
- Quad Full HDTV (3840 x 2160 pixels) resolution, true HDTV format
- LVDS (Low Voltage Differential Signaling) interface
- Optimized response time for 100Hz/120Hz frame rate
- Viewing Angle : 176(H)/176(V) (CR>20) VA Technology
- Ultra wide viewing angle: Super MVA technology
- RoHs compliance
- T-con input frame rate : FHD 50/60Hz, FHD 100/120Hz or QFHD 24/30Hz
- Output frame rate: QFHD 50/60Hz, QFHD 100/120Hz or QFHD 48/60Hz

1.3 APPLICATION

- Standard Living Room TVs
- Public Display Application
- Home Theater Application
- MFM Application

1.4 GENERAL SPECIFICATIONS

Item	Specification	Unit	Note
Active Area	919.296 (H) x 517.104 (V)	mm	(1)
Bezel Opening Area	924.296 (H) x 522.104 (V)	mm	
Driver Element	a-si TFT active matrix	-	-
Pixel Number	3840 x R.G.B. x 2160	pixel	-
Pixel Pitch(Sub Pixel)	0.0798 (H) x 0.2394 (V)	mm	-
Pixel Arrangement	RGB vertical stripe	-	-
Display Colors	1.07G colors (8-bit+FRC)	color	-
Display Operation Mode	Transmissive mode / Normally black	-	-
Surface Treatment	Anti-Glare coating (Haze 1%)	-	(2)
Rotation Function	Achievable		(3)
Display Orientation	Signal input with "INX"		(3)

Note (1) Please refer to the attached drawings in chapter 11 for more information about the front and back outlines.

Note (2) The spec of the surface treatment is temporarily for this phase. INX reserves the rights to change this feature.

Note (3)

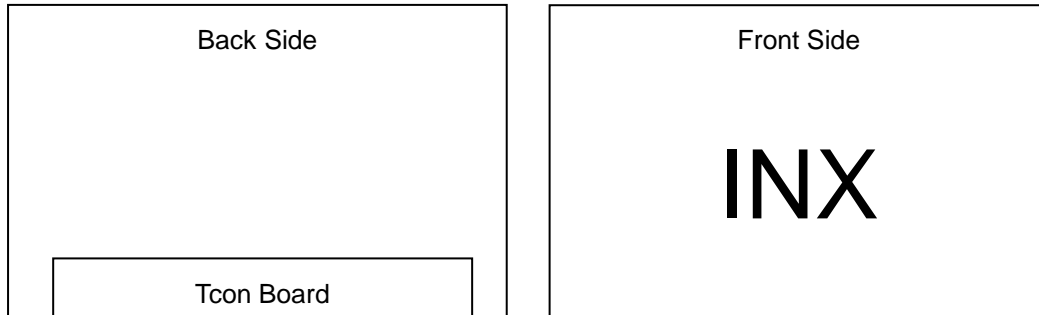

1.5 MECHANICAL SPECIFICATIONS

Item		Min.	Typ.	Max.	Unit	Note
Module Size	Horizontal (H)	935.3	936.3	937.3	mm	(1),(2)
	Vertical (V)	537.1	538.1	539.1	mm	(1),(2)
	Depth (D)	15.2	16.2	17.2	mm	To Rear
24.6		25.6	26.6	mm	To converter cover	
Weight		8170	8600	9030	g	

Note (1) Please refer to the attached drawings for more information of front and back outline dimensions.

Note (2) Module Depth does not include connectors.

2. ABSOLUTE MAXIMUM RATINGS

2.1 ABSOLUTE RATINGS OF ENVIRONMENT

Item	Symbol	Value		Unit	Note
		Min.	Max.		
Storage Temperature	T _{ST}	-20	+60	°C	(1)
Operating Ambient Temperature	T _{OP}	0	50	°C	(1), (2)
Shock (Non-Operating)	S _{NOP}	-	50	G	(3), (5)
Vibration (Non-Operating)	V _{NOP}	-	1.0	G	(4), (5)

Note (1) Temperature and relative humidity range is shown in the figure below.

- (a) 90 %RH Max. (Ta ≤ 40 °C).
- (b) Wet-bulb temperature should be 39 °C Max. (Ta > 40 °C).
- (c) No condensation.

Note (2) The maximum operating temperature is based on the test condition that the surface temperature of display area is less than or equal to 65 °C with LCD module alone in a temperature controlled chamber. Thermal management should be considered in final product design to prevent the surface temperature of display area from being over 65 °C. The range of operating temperature may degrade in case of improper thermal management in final product design.

Note (3) 11 ms, half sine wave, 1 time for ± X, ± Y, ± Z.

Note (4) 10 ~ 200 Hz, 30 min, 1 time each X, Y, Z.

Note (5) At testing Vibration and Shock, the fixture in holding the module has to be hard and rigid enough so that the module would not be twisted or bent by the fixture.

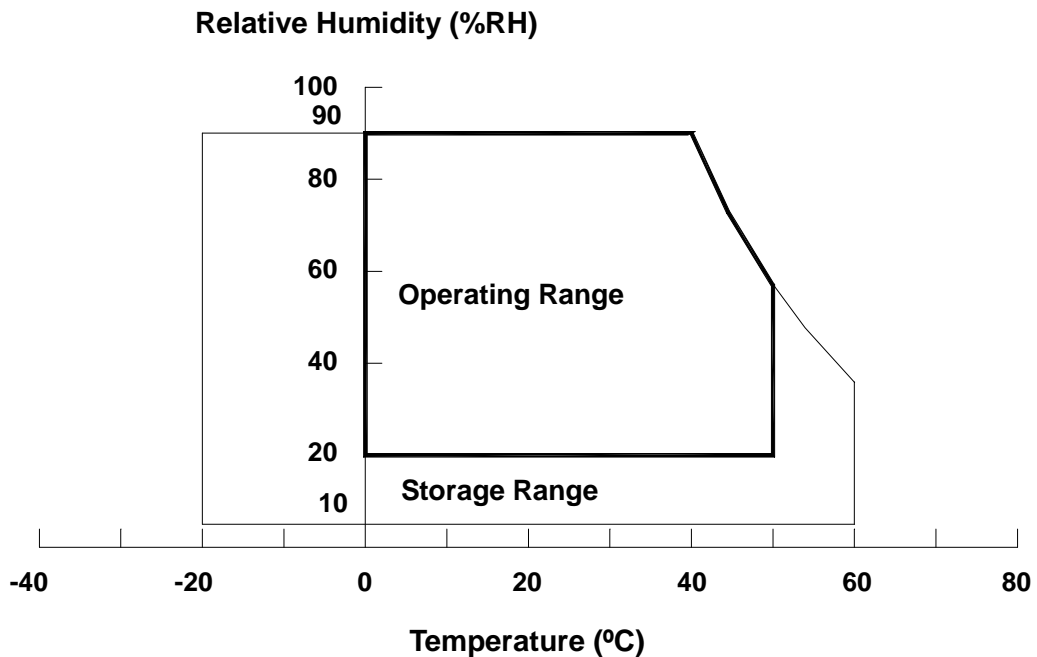

2.2 PACKAGE STORAGE

When storing modules as spares for a long time, the following precaution is necessary.

- (a) Do not leave the module in high temperature, and high humidity for a long time, It is highly recommended to store the module with temperature from 0 to 35 °C at normal humidity without condensation.
- (b) The module shall be stored in dark place. Do not store the TFT-LCD module in direct sunlight or fluorescent light.

2.3 ELECTRICAL ABSOLUTE RATINGS

2.3.1 TFT LCD MODULE

Item	Symbol	Value		Unit	Note
		Min.	Max.		
Power Supply Voltage	V _{CC}	-0.3	13.5	V	(1)
Logic Input Voltage	V _{IN}	-0.3	3.6	V	

2.3.2 BACKLIGHT CONVERTER UNIT

Item	Symbol	Test Condition	Min.	Type	Max.	Unit	Note
Light Bar Voltage	V _W	Ta = 25 °C	-	-	60	V _{RMS}	3D Mode
Converter Input Voltage	V _{BL}	-	0	-	30	V	
Control Signal Level	-	-	-0.3	-	6	V	

Note (1) Permanent damage to the device may occur if maximum values are exceeded. Function operation should be restricted to the conditions described under Normal Operating Conditions.

Note (2) No moisture condensation or freezing.

Note (3) The control signals include On/Off Control and External PWM Control.

3. ELECTRICAL CHARACTERISTICS

3.1 TFT LCD MODULE

(Ta = 25 ± 2 °C)

Parameter		Symbol	Value			Unit	Note
			Min.	Typ.	Max.		
Power Supply Voltage		V _{CC}	10.8	12	13.2	V	(1)
Rush Current		I _{RUSH}	—	—	2.8	A	(2)
QFHD 120Hz Output Power Consumption	White Pattern	P _T	—	9.48	11.28	W	(3)
	Horizontal Stripe	P _T	—	20.88	25.20	W	
	Black Pattern	P _T	—	9.36	11.04	W	
QFHD 120Hz Output Power Supply Current	White Pattern	—	—	0.79	0.94	A	
	Horizontal Stripe	—	—	1.74	2.10	A	
	Black Pattern	—	—	0.78	0.92	A	
QFHD 60Hz Output Power Consumption	White Pattern	P _T	—	9.00	10.80	W	
	Horizontal Stripe	P _T	—	20.16	23.52	W	
	Black Pattern	P _T	—	8.88	10.20	W	
QFHD 60Hz Output Power Supply Current	White Pattern	—	—	0.75	0.90	A	
	Horizontal Stripe	—	—	1.68	1.96	A	
	Black Pattern	—	—	0.74	0.85	A	
LVDS interface	Differential Input High Threshold Voltage	V _{LVTH}	+100	—	+300	mV	(4)
	Differential Input Low Threshold Voltage	V _{LVTL}	-300	—	-100	mV	
	Common Input Voltage	V _{CM}	1.0	1.2	1.4	V	
	Differential input voltage (single-end)	V _{ID}	200	—	600	mV	
	Terminating Resistor	R _T	—	100	—	ohm	
CMOS interface	Input High Threshold Voltage	V _{IH}	2.7	—	3.3	V	
	Input Low Threshold Voltage	V _{IL}	0	—	0.7	V	

Note (1) The module should be always operated within the above ranges. The ripple voltage should be controlled under 10% of V_{CC} (Typ.)

Note (2) Measurement condition :

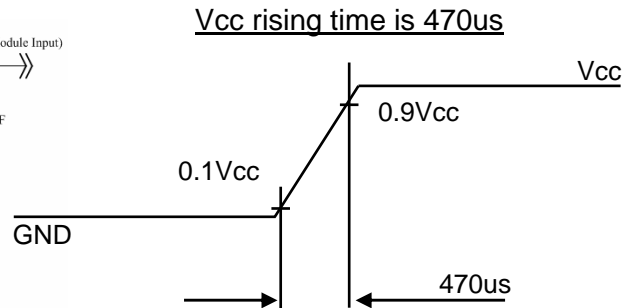
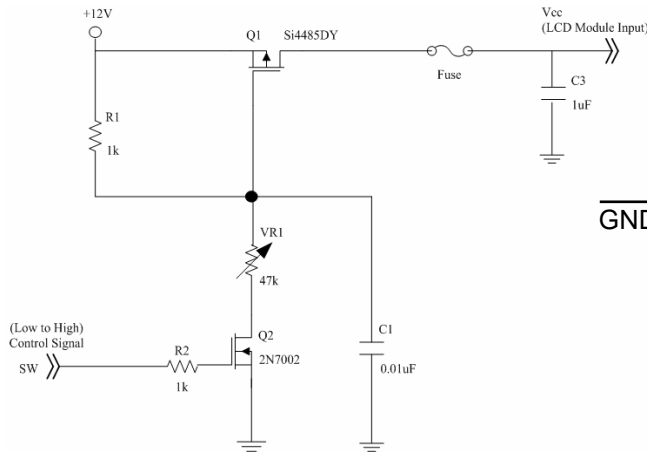

Note (3) The specified power supply current is under the conditions at $V_{cc} = 12\text{ V}$, $T_a = 25 \pm 2\text{ }^\circ\text{C}$, $f_v = 60/120\text{ Hz}$, whereas a power dissipation check pattern below is displayed.

a. White Pattern

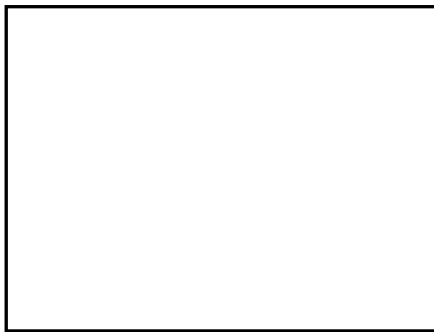

Active Area

b. Black Pattern



Active Area

c. Horizontal Pattern

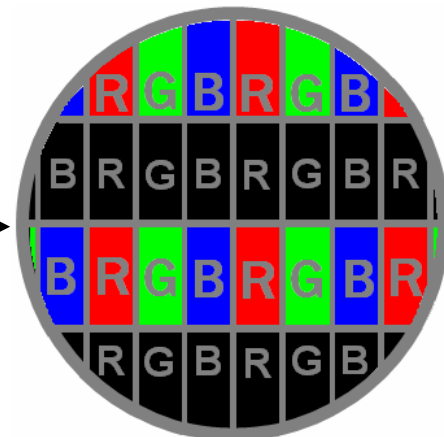
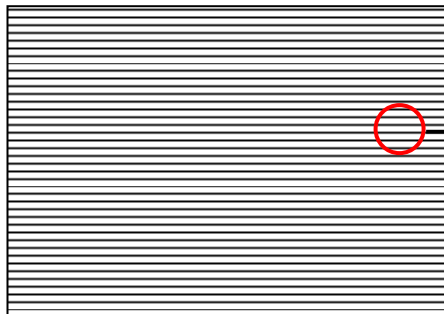

Note (4) The LVDS input characteristics is shown as below :

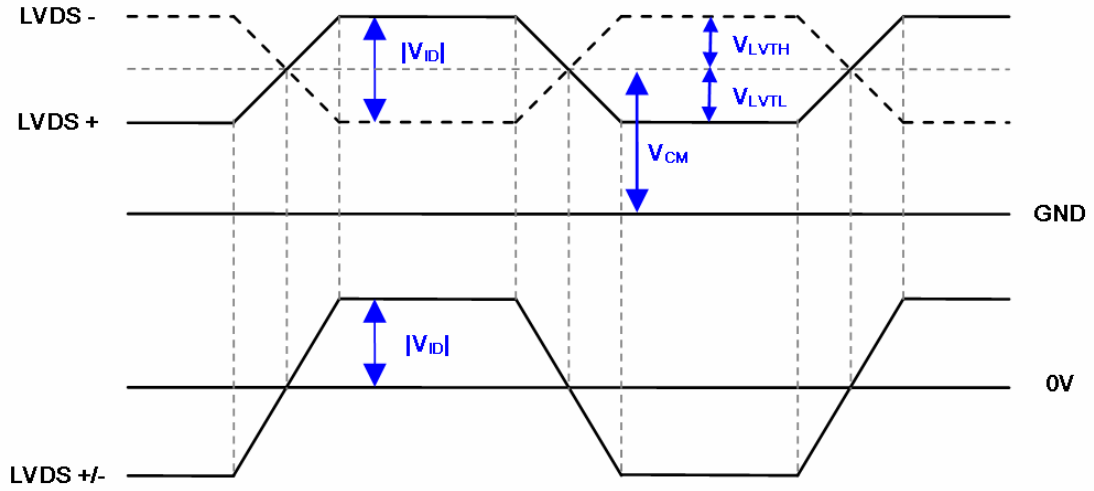

3.2 BACKLIGHT UNIT

3.2.1 CONVERTER CHARACTERISTICS

Parameter	Symbol	Value			Unit	Note
		Min.	Typ.	Max.		
Power Consumption	$P_{BL(2D)}$	—	44.9	51.7	W	(1), (2)
	$P_{BL(3D)}$	—	36.3	40.7	W	(1), (2)
Converter Input Voltage	VBL	22.8	24.0	25.2	VDC	
Converter Input Current	$I_{BL(2D)}$	—	1.87	2.2	A	Non Dimming
	$I_{BL(3D)}$	—	1.63	1.73	A	
Input Inrush Current	$I_{R(2D)}$	—	—	3.9	Apeak	$V_{BL}=22.8V$ (3), (6)
	$I_{R(3D)}$	—	—	5.4	Apeak	$V_{BL}=22.8V$ (3), (6)
Dimming Frequency	FB	170	180	190	Hz	(5)
Dimming Duty Ratio	DDR	5	-	100	%	(4), (5)
Life Time	-	30,000	-	-	Hrs	(7)

Note (1) The power supply capacity should be higher than the total converter power consumption P_{BL} . Since the pulse width modulation (PWM) mode was applied for backlight dimming, the driving current changed as PWM duty on and off. The transient response of power supply should be considered for the changing loading when converter dimming.

Note (2) The measurement condition of Max. value is based on 39" backlight unit under input voltage 24V, at 2D/3D Mode and lighting 1 hour later.

Note (3) For input inrush current measure, the VBL rising time from 10% to 90% is about 20ms.

Note (4) EPWM signal have to input available duty range. Between 97% and 100% duty (DDR) have to be avoided. (97% < DDR < 100%) But 100% duty(DDR) is possible. 5% duty (DDR) is only valid for electrical operation.

Note (5) FB and DDR are available only at 2D Mode.

Note (6) Below diagram is only for power supply design reference.

Test Condition : $V_{BL}=22.8V$, at 2D Mode / at 3D Mode

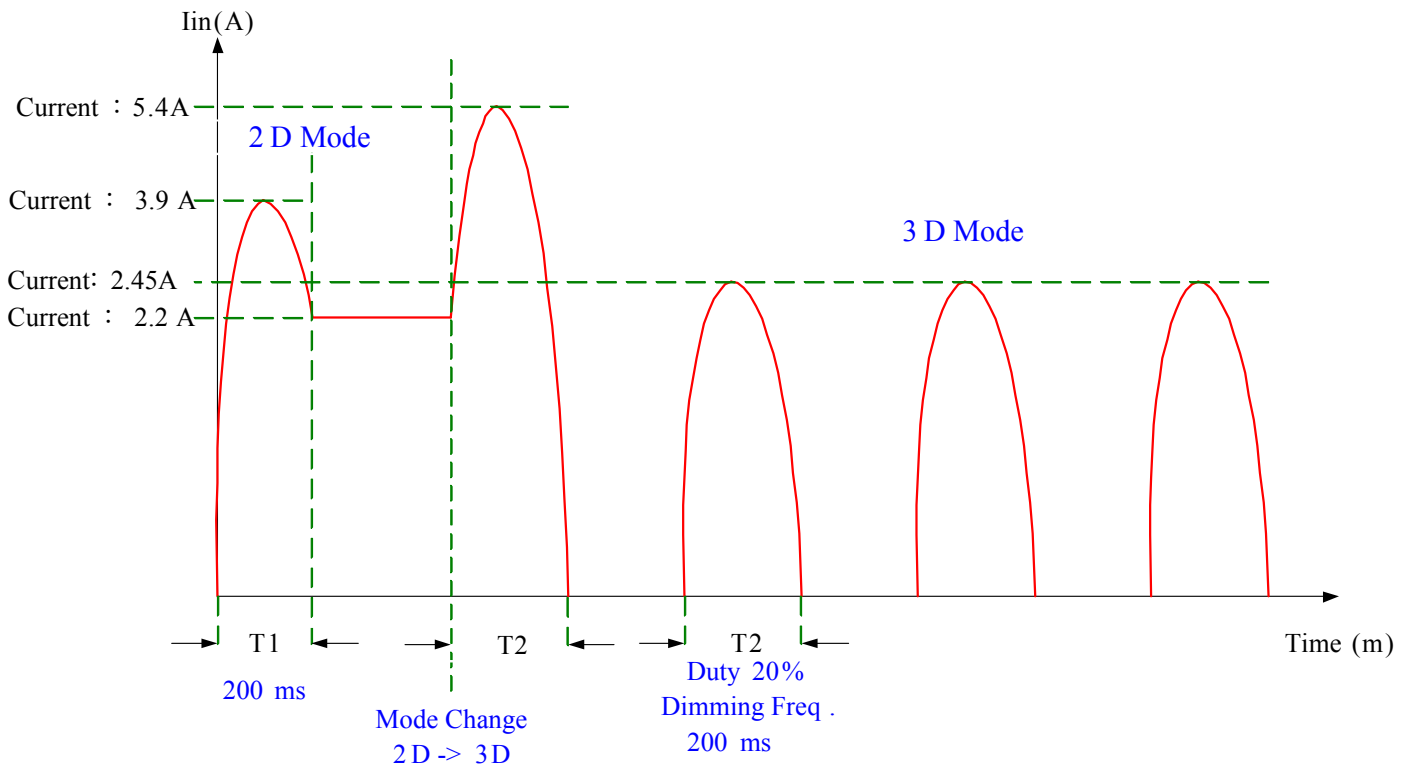

Note (7) The lifetime is defined as the time which luminance of the LED decays to 50% compared to the initial value,
Operating condition: Continuous operating at $T_a = 25\pm 2^\circ\text{C}$

3.2.2 CONVERTER INTERFACE CHARACTERISTICS

Parameter	Symbol	Test Condition	Value			Unit	Note		
			Min.	Typ.	Max.				
On/Off Control Voltage	ON	VBLON	—	2.0	—	5.0	V		
	OFF		—	0	—	0.8	V		
External PWM Control Voltage	HI	VEPWM	—	2.0	—	5.25	V	Duty on	(5), (6)
	LO		—	0	—	0.8	V	Duty off	
External PWM Frequency	F_{EPWM}	—	150	160	170	Hz	Normal mode (7)		
Error Signal	ERR	—	—	—	—	—	Abnormal: Open		
VBL Rising Time	T_{r1}	—	20	—	—	ms	10%-90% V_{BL}		
Control Signal Rising Time	T_r	—	—	—	100	ms			
Control Signal Falling Time	T_f	—	—	—	100	ms			
PWM Signal Rising Time	TPWMR	—	—	—	50	us	(6)		
PWM Signal Falling Time	TPWMF	—	—	—	50	us			
Input Impedance	R_{in}	—	1	—	—	MΩ	EPWM, BLON		
PWM Delay Time	TPWM	—	100	—	—	ms	(6)		
BLON Delay Time	T_{on}	—	300	—	—	ms			
	T_{on1}	—	300	—	—	ms			
BLON Off Time	T_{off}	—	300	—	—	ms			

Note (1) The Dimming signal should be valid before backlight turns on by BLON signal. It is inhibited to change the external PWM signal during backlight turn on period.

Note (2) The power sequence and control signal timing are shown in the Fig.1. For a certain reason, the converter has a possibility to be damaged with wrong power sequence and control signal timing.

Note (3) While system is turned ON or OFF, the power sequences must follow as below descriptions:

Turn ON sequence: VBL → PWM signal → BLON

Turn OFF sequence: BLOFF → PWM signal → VBL

Note (4) When converter protective function is triggered, ERR will output open collector status. Please refers to Fig.2.

Note (5) The EPWM interface that inserts a pull up resistor to 5V in Max Duty (100%), please refers to Fig.3.

Note (6) EPWM is available only at 2D Mode.

Note (7) EPWM signal have to input available frequency range.

Note (8) [Recommend] EPWM duty ratio is set at 100%(Max. Brightness) in 3D Mode.

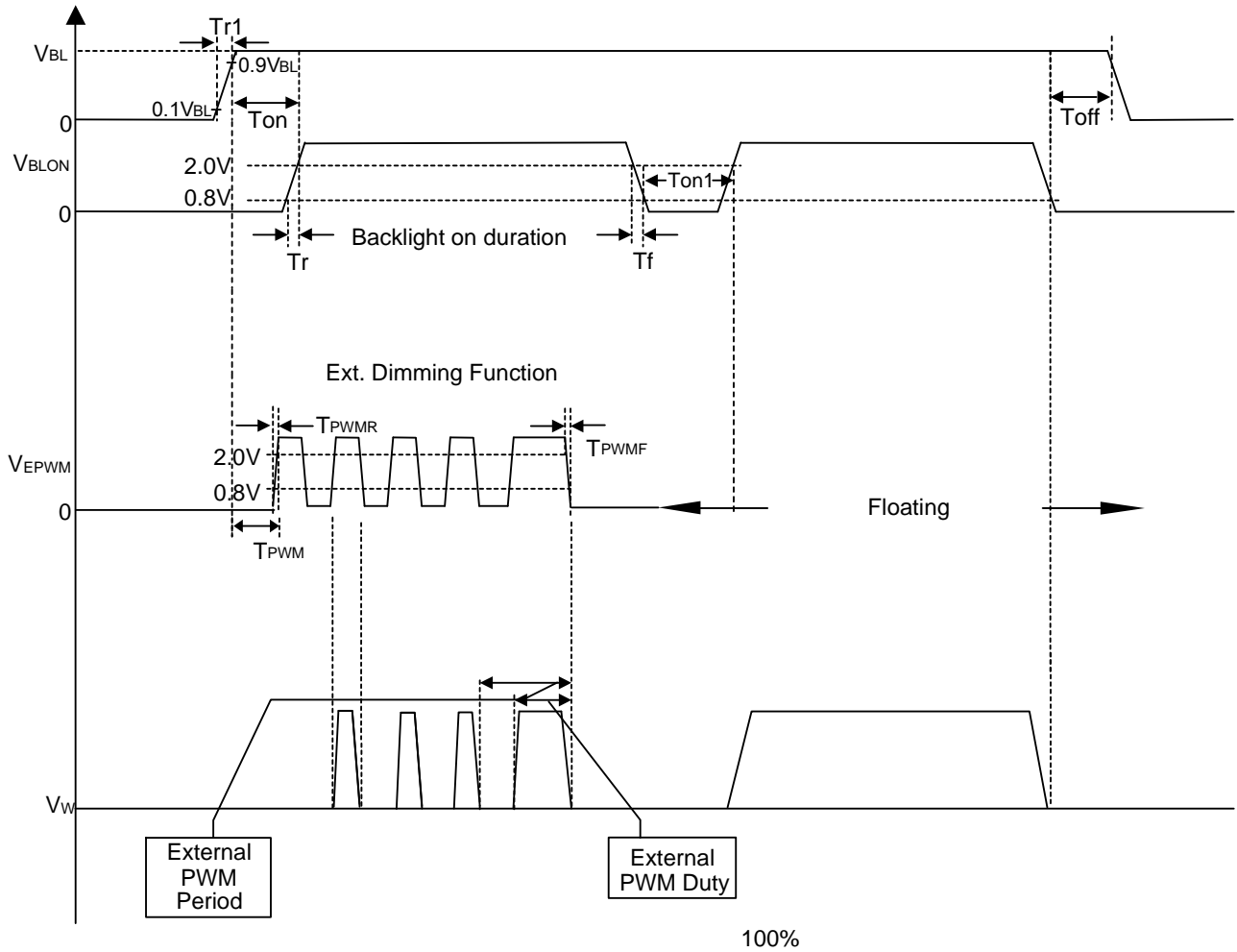

Fig. 1

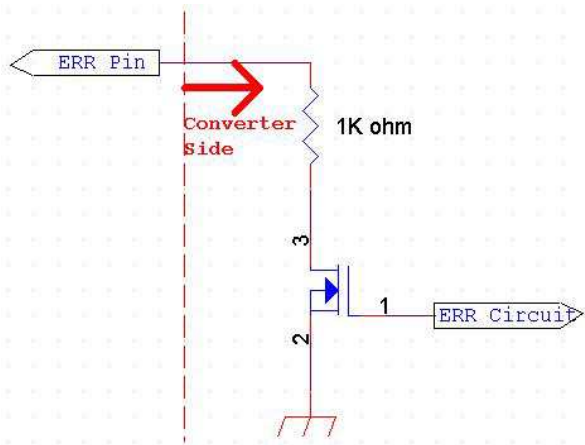

Fig. 2

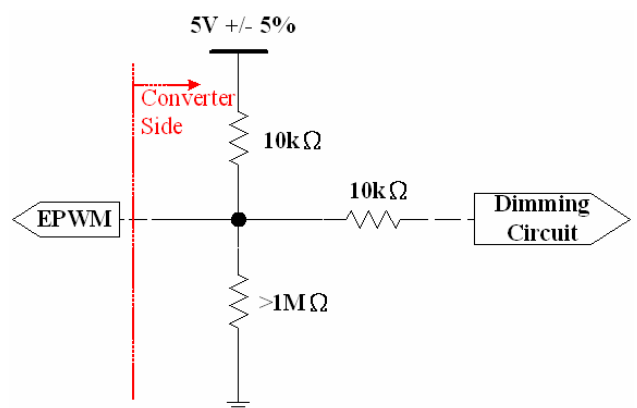
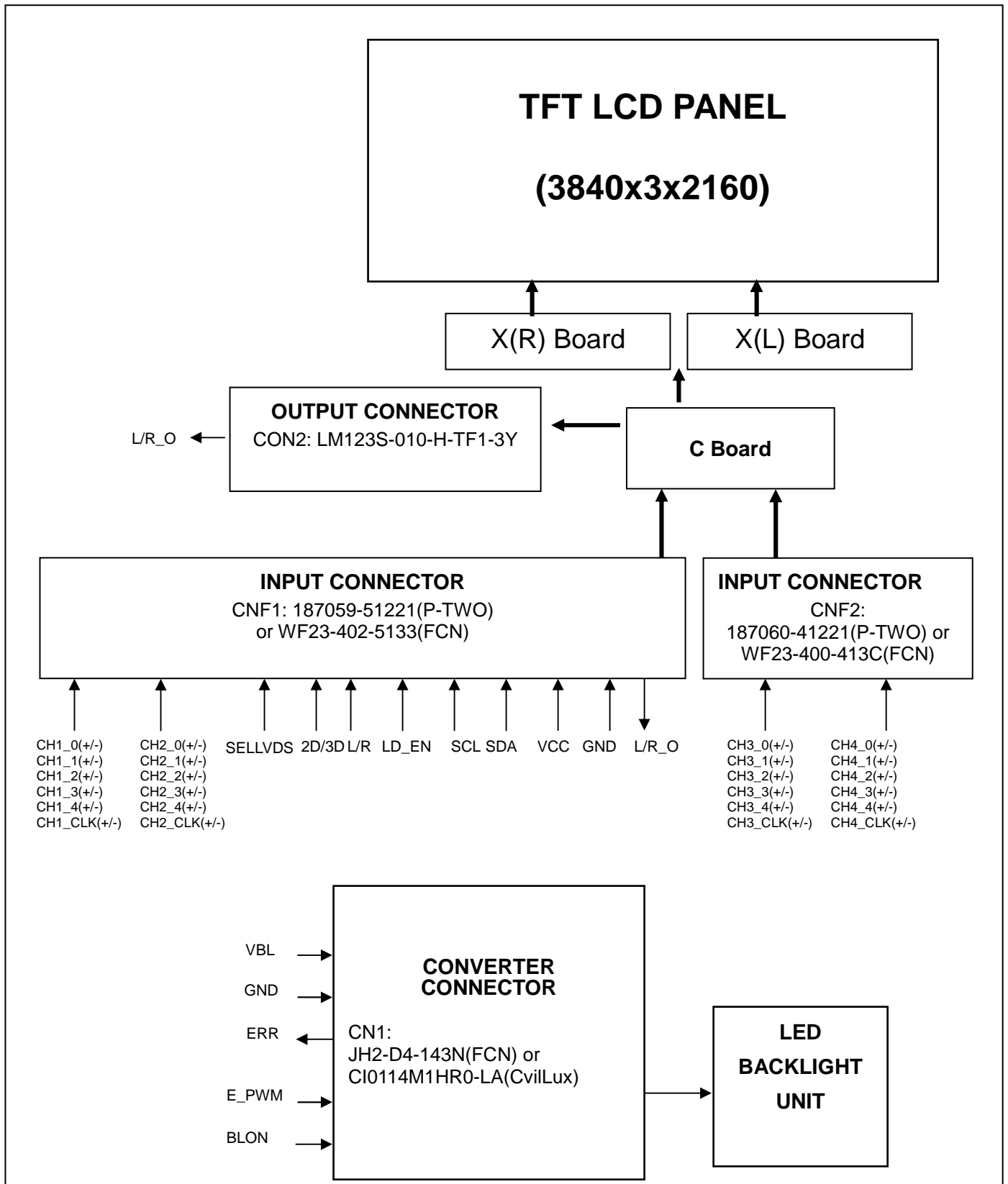

Fig. 3

4. BLOCK DIAGRAM OF INTERFACE

4.1 TFT LCD MODULE



5 .INPUT TERMINAL PIN ASSIGNMENT

5.1 TFT LCD MODULE

CNF1 Connector Pin Assignment (187059-51221(P-TWO) or WF23-402-5133 (FCN))

Matting connector: FI-RE51HL (JAE)

Pin	Name	Description	Note
1	N.C.	No Connection	(1)
2	SCL	I2C Clock (for mode selection & function setting)	
3	SDA	I2C Data (for mode selection & function setting)	
4	N.C.	No Connection	(1)
5	L/R_O	Output signal for Left Right Glasses control	(2)
6	N.C.	No Connection	(1)
7	SELLVDS	Input signal for LVDS Data Format Selection	(3)(9)
8	N.C.	No Connection	(1)
9	N.C.	No Connection	
10	N.C.	No Connection	
11	GND	Ground	
12	CH1[0]-	First pixel Negative LVDS differential data input. Pair 0	(4)
13	CH1[0]+	First pixel Positive LVDS differential data input. Pair 0	
14	CH1[1]-	First pixel Negative LVDS differential data input. Pair 1	
15	CH1[1]+	First pixel Positive LVDS differential data input. Pair 1	
16	CH1[2]-	First pixel Negative LVDS differential data input. Pair 2	
17	CH1[2]+	First pixel Positive LVDS differential data input. Pair 2	
18	GND	Ground	
19	CH1CLK-	First pixel Negative LVDS differential clock input.	(4)
20	CH1CLK+	First pixel Positive LVDS differential clock input.	
21	GND	Ground	
22	CH1[3]-	First pixel Negative LVDS differential data input. Pair 3	(4)
23	CH1[3]+	First pixel Positive LVDS differential data input. Pair 3	
24	CH1[4]-	First pixel Negative LVDS differential data input. Pair 4	
25	CH1[4]+	First pixel Positive LVDS differential data input. Pair 4	
26	2D/3D	Input signal for 2D/3D Mode Selection	(5)(10)
27	L/R	Input signal for Left Right eye frame synchronous	(6)
28	CH2[0]-	Second pixel Negative LVDS differential data input. Pair 0	(4)

29	CH2[0]+	Second pixel Positive LVDS differential data input. Pair 0	
30	CH2[1]-	Second pixel Negative LVDS differential data input. Pair 1	
31	CH2[1]+	Second pixel Positive LVDS differential data input. Pair 1	
32	CH2[2]-	Second pixel Negative LVDS differential data input. Pair 2	
33	CH2[2]+	Second pixel Positive LVDS differential data input. Pair 2	
34	GND	Ground	
35	CH2CLK-	Second pixel Negative LVDS differential clock input.	(4)
36	CH2CLK+	Second pixel Positive LVDS differential clock input.	
37	GND	Ground	
38	CH2[3]-	Second pixel Negative LVDS differential data input. Pair 3	(4)
39	CH2[3]+	Second pixel Positive LVDS differential data input. Pair 3	
40	CH2[4]-	Second pixel Negative LVDS differential data input. Pair 4	
41	CH2[4]+	Second pixel Positive LVDS differential data input. Pair 4	
42	LD_EN	Input signal for Local Dimming Enable	(7)(9)
43	N.C.	No Connection	(8)
44	GND	Ground	
45	GND	Ground	
46	GND	Ground	
47	N.C.	No Connection	(1)
48	VCC	+12V power supply	
49	VCC	+12V power supply	
50	VCC	+12V power supply	
51	VCC	+12V power supply	

CNF2 Connector pin assignment (187060-41221 (P-TWO) or WF23-400-413C (FCN))

Matting connector: FI-RE41HL (JAE)

Pin	Name	Description	Note
1	N.C.	No Connection	(1)
2	N.C.	No Connection	
3	N.C.	No Connection	
4	N.C.	No Connection	
5	N.C.	No Connection	
6	N.C.	No Connection	

7	N.C.	No Connection	
8	N.C.	No Connection	
9	GND	Ground	
10	CH3[0]-	Third pixel Negative LVDS differential data input. Pair 0	(4)
11	CH3[0]+	Third pixel Positive LVDS differential data input. Pair 0	
12	CH3[1]-	Third pixel Negative LVDS differential data input. Pair 1	
13	CH3[1]+	Third pixel Positive LVDS differential data input. Pair 1	
14	CH3[2]-	Third pixel Negative LVDS differential data input. Pair 2	
15	CH3[2]+	Third pixel Positive LVDS differential data input. Pair 2	
16	GND	Ground	
17	CH3CLK-	Third pixel Negative LVDS differential clock input.	(4)
18	CH3CLK+	Third pixel Positive LVDS differential clock input.	
19	GND	Ground	
20	CH3[3]-	Third pixel Negative LVDS differential data input. Pair 3	(4)
21	CH3[3]+	Third pixel Positive LVDS differential data input. Pair 3	
22	CH3[4]-	Third pixel Negative LVDS differential data input. Pair 4	
23	CH3[4]+	Third pixel Positive LVDS differential data input. Pair 4	
24	GND	Ground	
25	GND	Ground	
26	CH4[0]-	Fourth pixel Negative LVDS differential data input. Pair 0	(4)
27	CH4[0]+	Fourth pixel Positive LVDS differential data input. Pair 0	
28	CH4[1]-	Fourth pixel Negative LVDS differential data input. Pair 1	
29	CH4[1]+	Fourth pixel Positive LVDS differential data input. Pair 1	
30	CH4[2]-	Fourth pixel Negative LVDS differential data input. Pair 2	
31	CH4[2]+	Fourth pixel Positive LVDS differential data input. Pair 2	
32	GND	Ground	
33	CH4CLK-	Fourth pixel Negative LVDS differential clock input.	(4)
34	CH4CLK+	Fourth pixel Positive LVDS differential clock input.	
35	GND	Ground	
36	CH4[3]-	Fourth pixel Negative LVDS differential data input. Pair 3	(4)
37	CH4[3]+	Fourth pixel Positive LVDS differential data input. Pair 3	
38	CH4[4]-	Fourth pixel Negative LVDS differential data input. Pair 4	

39	CH4[4]+	Fourth pixel Positive LVDS differential data input. Pair 4	
40	GND	Ground	
41	GND	Ground	

CON2 Connector Pin Assignment (LM123S010HTF13Y)

1	N.C.	No Connection	(1)
2	N.C.	No Connection	
3	N.C.	No Connection	
4	GND	Ground	—
5	N.C.	No Connection	(1)
6	L/R_O	Output signal for Left Right Glasses control	(2)
7	N.C.	No Connection	(1)
8	N.C.	No Connection	
9	N.C.	No Connection	
10	N.C.	No Connection	

Note (1) Reserved for internal use. Please leave it open.

Note (2) The definition of L/R_O signal as follows

L= 0V, H=+3.3V

L/R_O	Note
L	Right glass turn on
H	Left glass turn on

Note (3) LVDS format selection.

L= Connect to GND, H=Connect to +3.3V or Open

SELLVDS	Note
L	JEIDA Format
H or Open	VESA Format

Note (4) LVDS Data Mapping

LVDS 4-port FHD 100/120Hz Input

Port	Channel of LVDS	Data Stream
1st Port	First Pixel	1, 5, 9,1913, 1917
2nd Port	Second Pixel	2, 6, 10,1914, 1918
3rd Port	Third Pixel	3, 7, 11,1915, 1919
4th Port	Fourth Pixel	4, 8, 12,1916, 1920

LVDS 2port FHD 50/60Hz Input

Port	Channel of LVDS	Data Stream
1st Port	First Pixel	1, 3, 5,1917, 1919
2nd Port	Second Pixel	2, 4, 6,1918, 1920

LVDS 4-port QFHD 24/30Hz Input

Port	Channel of LVDS	Data Stream
1st Port	First Pixel	1, 5, 9,3833, 3837
2nd Port	Second Pixel	2, 6, 10,3834, 3838
3rd Port	Third Pixel	3, 7, 11,3835, 3839
4th Port	Fourth Pixel	4, 8, 12,3836, 3840

Note (5) 2D/3D mode selection.

L= Connect to GND or Open, H=Connect to +3.3V

2D/3D	Note
L or Open	2D Mode
H	3D Mode

Note (6) Input signal for left and right eye frame synchronous

$V_{IL}=0-0.7\text{ V}$, $V_{IH}=2.7-3.3\text{ V}$

L/R	Note
L	Right synchronous signal
H	Left synchronous signal

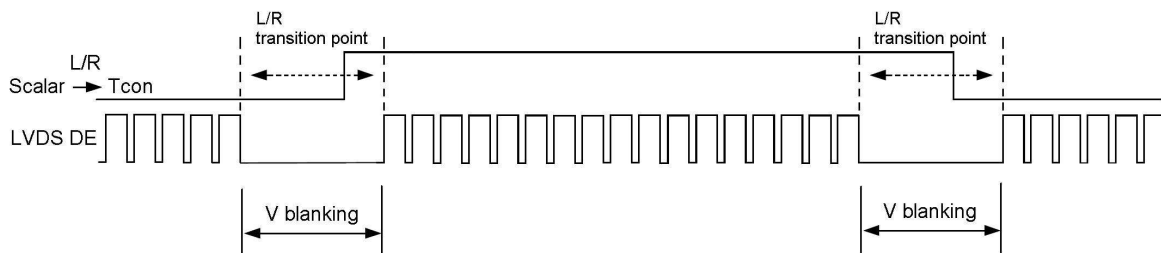

Note (7) Local dimming enable selection.

L= Connect to GND · H=Connect to +3.3V or Open

LD_EN	Note
L	Local Dimming Disable
H or Open	Local Dimming Enable

Note (8) Reserved for internal use. Open is preferred. However, it is also acceptable to reserve the wire connecting with specific High/Low voltage level.

Note (9) Interface optional pin has internal scheme as following diagram. Customer should keep the interface voltage level requirement which including panel board loading as below.

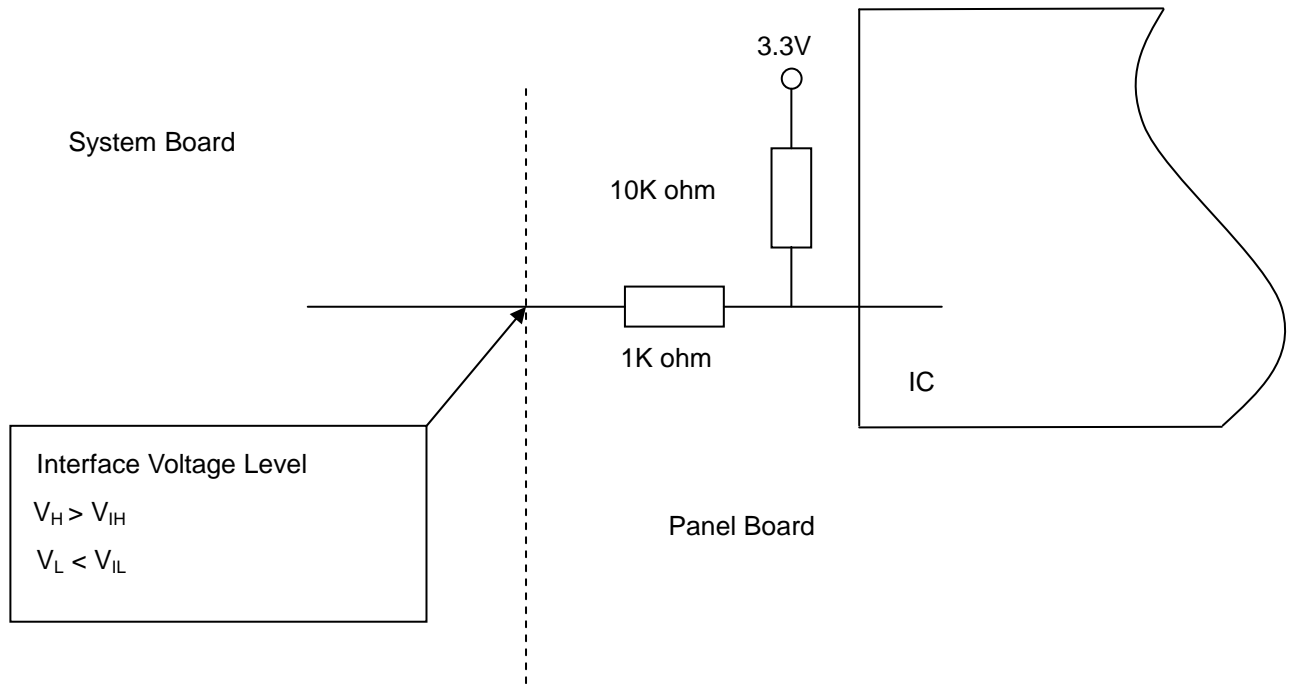

Note (10) Interface optional pin has internal scheme as following diagram. Customer should keep the interface voltage level requirement which including panel board loading as below.

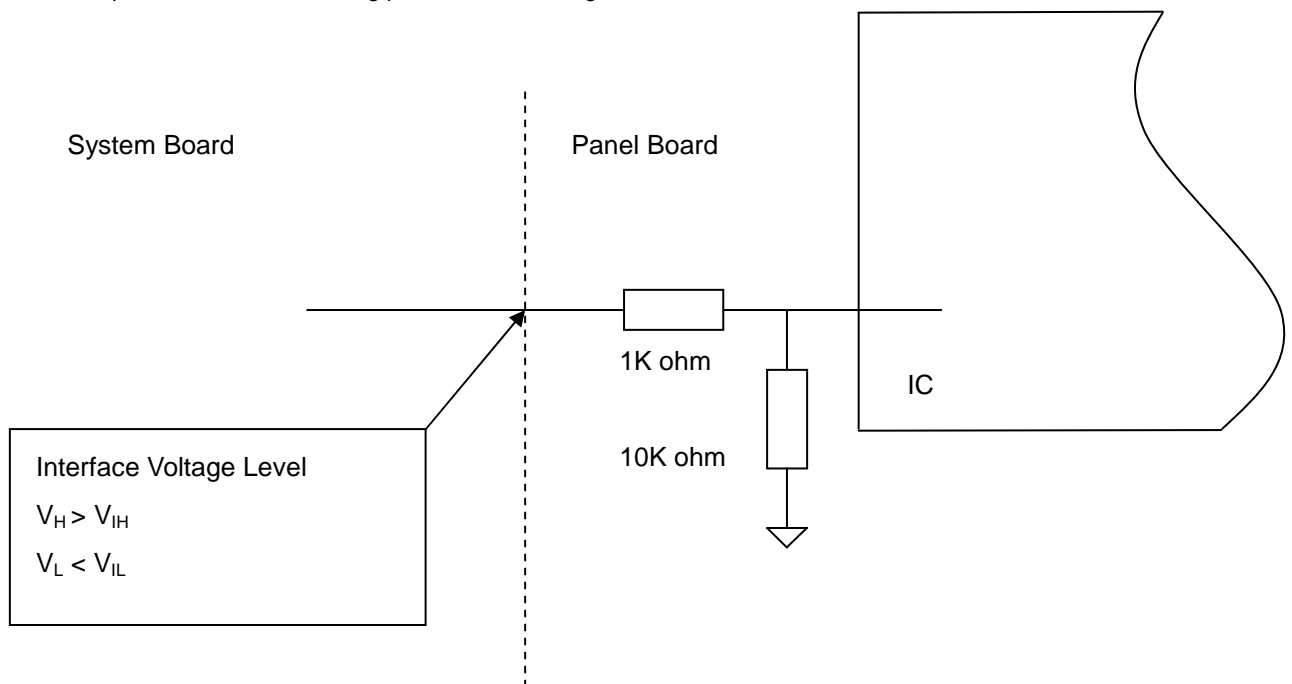

Note (11) LVDS connector pin order defined as follows

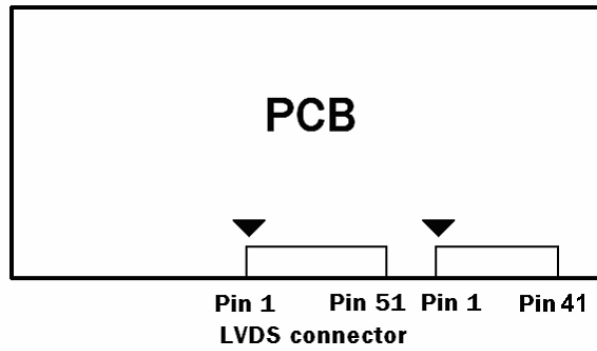

Note (12) LVDS connector mating dimension range request is 0.93mm~1.0mm as below

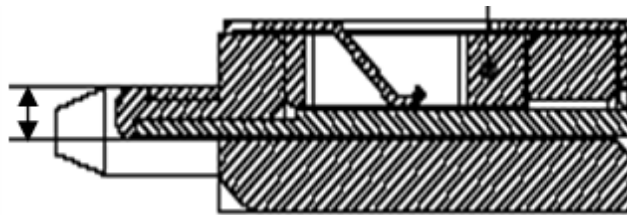

5.2 BACKLIGHT UNIT

The pin configuration for the housing and leader wire is shown in the table below.

CN2: FF01-430-123A(FCN) or 196388-12041-3(P-TWO).

Pin No	Symbol	Feature
1	VLED+	Positive of LED String
2	VLED+	
3	VLED+	
4	NC	NC
5	VLED-	Negative of LED String
6	VLED-	
7	VLED-	
8	VLED-	
9	VLED-	
10	VLED-	
11	VLED-	
12	VLED-	

5.3 CONVERTER UNIT

CN1 (Header) : JH2-D4-143N(FCN) or CI0114M1HR0-LA (CvilLux)

Pin No.	Symbol	Feature
1	VBL	+24V
2		
3		
4		
5		
6	GND	GND
7		
8		
9		
10		
11	ERR	Normal (GND) ; Abnormal (Open collector)
12	BLON	BL ON/OFF
13	NC	NC
14	E_PWM	External PWM Control

Note (1) If Pin14 is open, E_PWM is 100% duty.

Note (2) Input connector pin order defined as follows

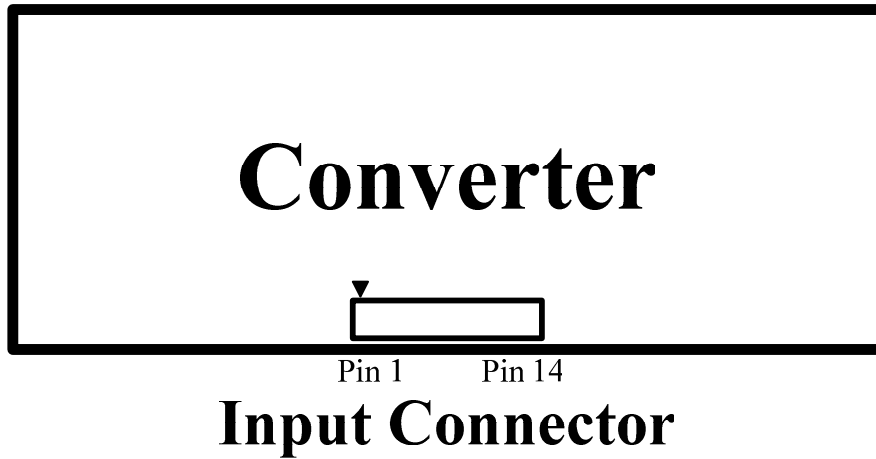

5.4 LVDS INTERFACE

JEIDA Format : SELLVDS = L

VESA Format : SELLVDS = H or Open

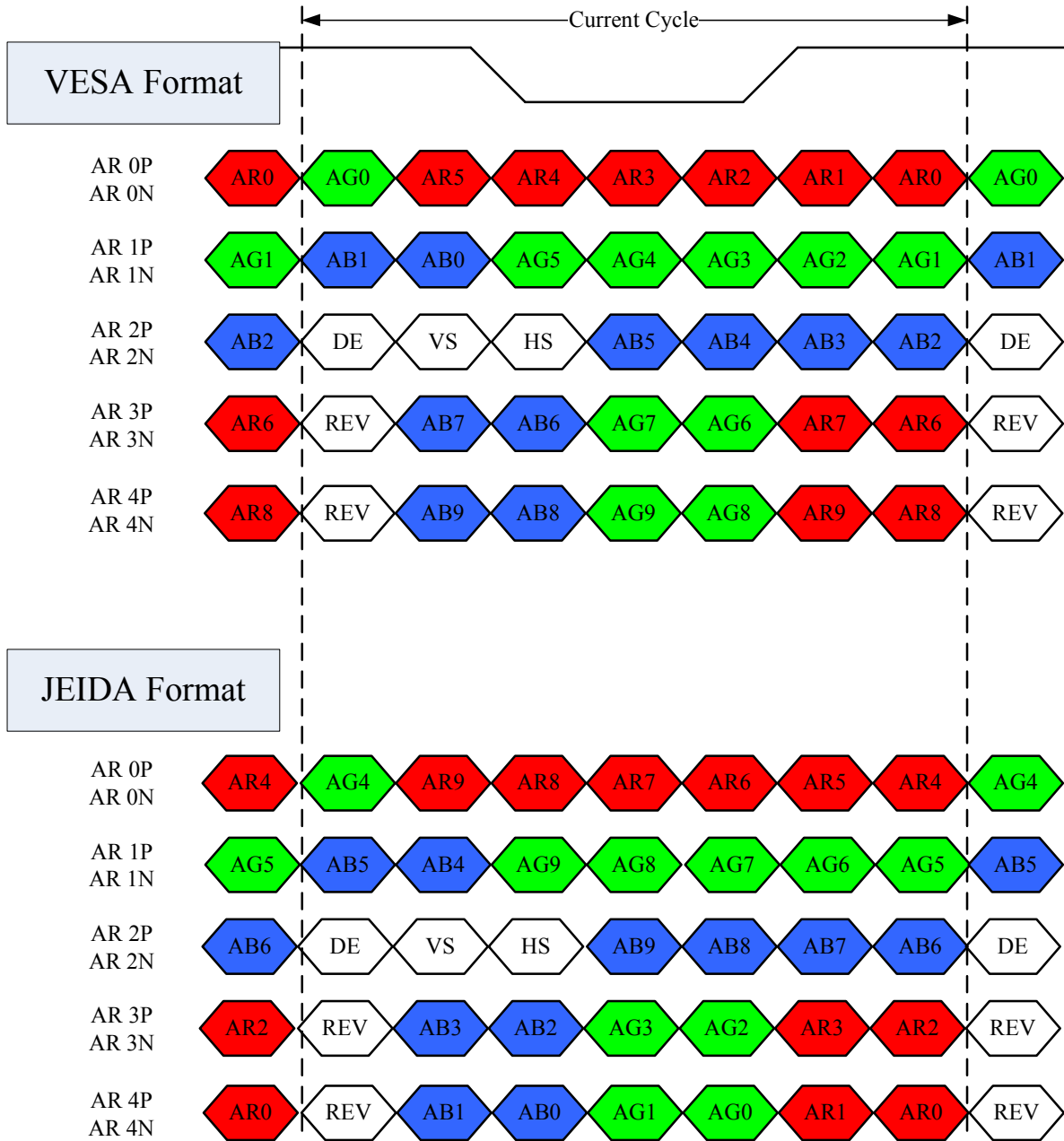

R0~R9: Pixel R Data (9; MSB, 0; LSB)

G0~G9: Pixel G Data (9; MSB, 0; LSB)

B0~B9: Pixel B Data (9; MSB, 0; LSB)

DE : Data enable signal

DCLK : Data clock signal

Notes: (1) RSVD (reserved) pins on the transmitter shall be "H" or "L".

5.5 COLOR DATA INPUT ASSIGNMENT

The brightness of each primary color (red, green and blue) is based on the 10-bit gray scale data input for the color. The higher the binary input the brighter the color. The table below provides the assignment of color versus data input.

Color		Data Signal																																						
		Red										Green										Blue																		
		R9	R8	R7	R6	R5	R4	R3	R2	R1	R0	G9	G8	G7	G6	G5	G4	G3	G2	G1	G0	B9	B8	B7	B6	B5	B4	B3	B2	B1	B0									
Basic Colors	Black	0	0	0	0	0	0	0	0	0	0	0	0	0	0	0	0	0	0	0	0	0	0	0	0	0	0	0	0	0	0	0	0	0	0	0	0	0	0	0
	Red	1	1	1	1	1	1	1	1	1	1	0	0	0	0	0	0	0	0	0	0	0	0	0	0	0	0	0	0	0	0	0	0	0	0	0	0	0	0	0
	Green	0	0	0	0	0	0	0	0	0	0	1	1	1	1	1	1	1	1	1	0	0	0	0	0	0	0	0	0	0	0	0	0	0	0	0	0	0	0	0
	Blue	0	0	0	0	0	0	0	0	0	0	0	0	0	0	0	0	0	0	0	1	1	1	1	1	1	1	1	1	1	0	0	0	0	0	0	0	0	0	0
	Cyan	0	0	0	0	0	0	0	0	0	0	1	1	1	1	1	1	1	1	1	1	1	1	1	1	1	1	1	1	1	0	0	0	0	0	0	0	0	0	0
	Magenta	1	1	1	1	1	1	1	1	1	1	0	0	0	0	0	0	0	0	0	0	0	0	0	0	0	0	0	0	0	1	1	1	1	1	1	1	1	1	1
	Yellow	1	1	1	1	1	1	1	1	1	1	1	1	1	1	1	1	1	1	1	0	0	0	0	0	0	0	0	0	0	1	1	1	1	1	1	1	1	1	1
	White	1	1	1	1	1	1	1	1	1	1	1	1	1	1	1	1	1	1	1	1	1	1	1	1	1	1	1	1	1	1	1	1	1	1	1	1	1	1	1
Gray Scale Of Red	Red (0) / Dark	0	0	0	0	0	0	0	0	0	0	0	0	0	0	0	0	0	0	0	0	0	0	0	0	0	0	0	0	0	0	0	0	0	0	0	0	0	0	
	Red (1)	0	0	0	0	0	0	0	0	0	1	0	0	0	0	0	0	0	0	0	0	0	0	0	0	0	0	0	0	0	0	0	0	0	0	0	0	0	0	
	Red (2)	0	0	0	0	0	0	0	0	1	0	0	0	0	0	0	0	0	0	0	0	0	0	0	0	0	0	0	0	0	0	0	0	0	0	0	0	0	0	
	⋮	⋮	⋮	⋮	⋮	⋮	⋮	⋮	⋮	⋮	⋮	⋮	⋮	⋮	⋮	⋮	⋮	⋮	⋮	⋮	⋮	⋮	⋮	⋮	⋮	⋮	⋮	⋮	⋮	⋮	⋮	⋮	⋮	⋮	⋮	⋮	⋮	⋮	⋮	
	⋮	⋮	⋮	⋮	⋮	⋮	⋮	⋮	⋮	⋮	⋮	⋮	⋮	⋮	⋮	⋮	⋮	⋮	⋮	⋮	⋮	⋮	⋮	⋮	⋮	⋮	⋮	⋮	⋮	⋮	⋮	⋮	⋮	⋮	⋮	⋮	⋮	⋮	⋮	⋮
	Red (1021)	1	1	1	1	1	1	1	1	0	1	0	0	0	0	0	0	0	0	0	0	0	0	0	0	0	0	0	0	0	0	0	0	0	0	0	0	0	0	
	Red (1022)	1	1	1	1	1	1	1	1	1	0	0	0	0	0	0	0	0	0	0	0	0	0	0	0	0	0	0	0	0	0	0	0	0	0	0	0	0	0	
	Red (1023)	1	1	1	1	1	1	1	1	1	1	0	0	0	0	0	0	0	0	0	0	0	0	0	0	0	0	0	0	0	0	0	0	0	0	0	0	0	0	
Gray Scale Of Green	Green (0) / Dark	0	0	0	0	0	0	0	0	0	0	0	0	0	0	0	0	0	0	0	0	0	0	0	0	0	0	0	0	0	0	0	0	0	0	0	0	0	0	
	Green (1)	0	0	0	0	0	0	0	0	0	0	0	0	0	0	0	0	0	1	0	0	0	0	0	0	0	0	0	0	0	0	0	0	0	0	0	0	0	0	
	Green (2)	0	0	0	0	0	0	0	0	0	0	0	0	0	0	0	0	1	0	0	0	0	0	0	0	0	0	0	0	0	0	0	0	0	0	0	0	0	0	
	⋮	⋮	⋮	⋮	⋮	⋮	⋮	⋮	⋮	⋮	⋮	⋮	⋮	⋮	⋮	⋮	⋮	⋮	⋮	⋮	⋮	⋮	⋮	⋮	⋮	⋮	⋮	⋮	⋮	⋮	⋮	⋮	⋮	⋮	⋮	⋮	⋮	⋮	⋮	
	⋮	⋮	⋮	⋮	⋮	⋮	⋮	⋮	⋮	⋮	⋮	⋮	⋮	⋮	⋮	⋮	⋮	⋮	⋮	⋮	⋮	⋮	⋮	⋮	⋮	⋮	⋮	⋮	⋮	⋮	⋮	⋮	⋮	⋮	⋮	⋮	⋮	⋮	⋮	
	Green (1021)	0	0	0	0	0	0	0	0	0	0	1	1	1	1	1	1	1	0	1	0	0	0	0	0	0	0	0	0	0	0	0	0	0	0	0	0	0	0	
	Green (1022)	0	0	0	0	0	0	0	0	0	0	1	1	1	1	1	1	1	1	0	0	0	0	0	0	0	0	0	0	0	0	0	0	0	0	0	0	0	0	
	Green (1023)	0	0	0	0	0	0	0	0	0	0	1	1	1	1	1	1	1	1	0	0	0	0	0	0	0	0	0	0	0	0	0	0	0	0	0	0	0	0	
Gray Scale Of Blue	Blue (0) / Dark	0	0	0	0	0	0	0	0	0	0	0	0	0	0	0	0	0	0	0	0	0	0	0	0	0	0	0	0	0	0	0	0	0	0	0	0	0	0	
	Blue (1)	0	0	0	0	0	0	0	0	0	0	0	0	0	0	0	0	0	0	0	0	0	0	0	0	0	0	0	0	0	0	0	0	0	0	0	0	0	1	
	Blue (2)	0	0	0	0	0	0	0	0	0	0	0	0	0	0	0	0	0	0	0	0	0	0	0	0	0	0	0	0	0	0	0	0	0	0	0	0	0	1	
	⋮	⋮	⋮	⋮	⋮	⋮	⋮	⋮	⋮	⋮	⋮	⋮	⋮	⋮	⋮	⋮	⋮	⋮	⋮	⋮	⋮	⋮	⋮	⋮	⋮	⋮	⋮	⋮	⋮	⋮	⋮	⋮	⋮	⋮	⋮	⋮	⋮	⋮	⋮	
	⋮	⋮	⋮	⋮	⋮	⋮	⋮	⋮	⋮	⋮	⋮	⋮	⋮	⋮	⋮	⋮	⋮	⋮	⋮	⋮	⋮	⋮	⋮	⋮	⋮	⋮	⋮	⋮	⋮	⋮	⋮	⋮	⋮	⋮	⋮	⋮	⋮	⋮	⋮	
	Blue (1021)	0	0	0	0	0	0	0	0	0	0	0	0	0	0	0	0	0	0	1	1	1	1	1	1	1	1	1	1	0	0	0	0	0	0	0	0	0	0	
	Blue (1022)	0	0	0	0	0	0	0	0	0	0	0	0	0	0	0	0	0	0	1	1	1	1	1	1	1	1	1	1	0	0	0	0	0	0	0	0	0	0	
	Blue (1023)	0	0	0	0	0	0	0	0	0	0	0	0	0	0	0	0	0	0	1	1	1	1	1	1	1	1	1	1	0	0	0	0	0	0	0	0	0	0	

Note (1) 0: Low Level Voltage , 1: High Level Voltage

6. INTERFACE TIMING

6.1 INPUT SIGNAL TIMING SPECIFICATIONS

The input signal timing specifications are shown as the following table and timing diagram. (Ta = 25 ± 2 °C)

Signal	Item	Symbol	Min.	Typ.	Max.	Unit	Note
LVDS Receiver Clock	Input cycle to cycle jitter	T _{rcl}	-	-	200	ps	(1)
	Spread spectrum modulation range	F _{clkin_mod}	F _{clkin} -1.5%	-	F _{clkin} +1.5%	MHz	(2)
	Spread spectrum modulation frequency	F _{SSM}	-	-	66	KHz	
LVDS Receiver Data	Receiver skew margin	T _{RSKM}	-400	-	400	ps	(3)

6.1.1 Input Timing Spec for FHD, Frame Rate = 50Hz

Signal	Item	Symbol	Min.	Typ.	Max.	Unit	Note	
LVDS Clock	Frequency	F _{clkin} (=1/TC)	60	74.25	79	MHz	(4)	
Frame Rate	2D Mode	F _r	47	50	53	Hz	(5)	
Vertical Active Display Term	2D Mode	Total	Tv	1104	1350	1395	Th	Tv=Tvd+Tvb
		Display	Tvd	1080			Th	
		Blank	Tvb	24	270	315	Th	
		Front porch	Tvfp	10	-	-	Th	(6)
		Back porch	Tvbp	10	-	-	Th	
		Vsync	Tvswid	4	-	-	Th	
Horizontal Active Display Term	2D Mode	Total	Th	1060	1100	1340	Tc	Th=Thd+Thb
		Display	Thd	960			Tc	
		Blank	Thb	100	140	380	Tc	
		Front porch	Thfp	5	-	-	Tc	(6)
		Back porch	Thbp	5	-	-	Tc	
		Hsync	Thswid	2	-	-	Tc	

6.1.2 Input Timing Spec for FHD, Frame Rate = 60Hz

Signal	Item	Symbol	Min.	Typ.	Max.	Unit	Note	
LVDS Clock	Frequency	$F_{clk_{in}}$ (=1/TC)	60	74.25	79	MHz	(4)	
Frame Rate	2D Mode	F_r	57	60	63	Hz	(5)	
Vertical Active Display Term	2D Mode	Total	Tv	1104	1125	1395	Th	Tv=Tvd+Tvb
		Display	Tvd	1080			Th	
		Blank	Tvb	24	45	315	Th	
		Front porch	Tvfp	10	—	—	Th	(6)
		Back porch	Tvbp	10	—	—	Th	
		Vsync	Tvswid	4	—	—	Th	
Horizontal Active Display Term	2D Mode	Total	Th	1060	1100	1340	Tc	Th=Thd+Thb
		Display	Thd	960			Tc	
		Blank	Thb	100	140	380	Tc	
		Front porch	Thfp	5	—	—	Tc	(6)
		Back porch	Thbp	5	—	—	Tc	
		Hsync	Thswid	2	—	—	Tc	

6.1.3 Input Timing Spec for FHD, Frame Rate = 100Hz

Signal	Item	Symbol	Min.	Typ.	Max.	Unit	Note	
LVDS Clock	Frequency	$F_{clk_{in}}$ (=1/TC)	60	74.25	79	MHz	(4)	
Frame Rate	2D Mode	F_r	97	100	103	Hz	(5)	
Vertical Active Display Term	2D Mode	Total	Tv	1104	1350	1395	Th	Tv=Tvd+Tvb
		Display	Tvd	1080			Th	
		Blank	Tvb	24	270	315	Th	
		Front porch	Tvfp	10	—	—	Th	(6)
		Back porch	Tvbp	10	—	—	Th	
		Vsync	Tvswid	4	—	—	Th	
Horizontal Active	2D Mode	Total	Th	530	550	670	Tc	Th=Thd+Thb
		Display	Thd	480			Tc	

Display Term	Blank	Thb	50	70	190	Tc	(6)
	Front porch	Thfp	5	—	—	Tc	
	Back porch	Thbp	5	—	—	Tc	
	Hsync	Thswid	2	—	—	Tc	

6.1.4 Input Timing Spec for FHD, Frame Rate = 120Hz

Signal	Item	Symbol	Min.	Typ.	Max.	Unit	Note	
LVDS Clock	2D Mode	$F_{clk_{in}}$	60	74.25	79	MHz	(4)	
	3D Mode	(=1/TC)	74.25			MHz		
Frame Rate	2D Mode	F_r	117	120	123	Hz	(5)	
	3D Mode		120			Hz		
Vertical Active Display Term	2D Mode	Total	Tv	1104	1125	1395	Th	Tv=Tvd+Tvb
		Display	Tvd	1080			Th	
		Blank	Tvb	24	45	315	Th	
		Front porch	Tvfp	10	—	—	Th	(6)
		Back porch	Tvbp	10	—	—	Th	
		Vsync	Tvswid	4	—	—	Th	
	3D Mode	Total	Tv	1125			Th	
		Display	Tvd	1080			Th	
		Blank	Tvb	45			Th	
		Front porch	Tvfp	10	—	—	—	(6)
		Back porch	Tvbp	10	—	—	—	
		Vsync	Tvswid	4	—	—	—	
Horizontal Active Display Term	2D Mode	Total	Th	530	550	670	Tc	Th=Thd+Thb
		Display	Thd	480			Tc	
		Blank	Thb	50	70	190	Tc	
		Front porch	Thfp	5	—	—	Tc	(6)
		Back porch	Thbp	5	—	—	Tc	
		Hsync	Thswid	2	—	—	Tc	
	3D Mode	Total	Th	530	550	670	Tc	Th=Thd+Thb

		Display	Thd	480			Tc	
		Blank	Thb	50	70	190	Tc	
		Front porch	Thfp	5	—	—	Tc	(6)
		Back porch	Thbp	5	—	—	Tc	
		Hsync	Thswid	2	—	—	Tc	

6.1.5 Input Timing spec for QFHD, Frame Rate = 24Hz

Signal	Item	Symbol	Min.	Typ.	Max.	Unit	Note	
LVDS Clock	Frequency	$F_{clk_{in}}$ (=1/TC)	60	74.25	79	MHz	(4)	
Frame Rate	2D Mode	F_r	23	24	25	Hz	(5)	
Vertical Active Display Term	2D Mode	Total	Tv	2208	2250	2450	Th	Tv=Tvd+Tvb
		Display	Tvd	2160			Th	
		Blank	Tvb	48	90	290	Th	
		Front porch	Tvfp	20	—	—	Th	(6)
		Back porch	Tvbp	20	—	—	Th	
		Vsync	Tvswid	8	—	—	Th	
Horizontal Active Display Term	2D Mode	Total	Th	992	1375	1440	Tc	Th=Thd+Thb
		Display	Thd	960			Tc	
		Blank	Thb	32	415	480	Tc	
		Front porch	Thfp	12	—	—	Tc	(6)
		Back porch	Thbp	10	—	—	Tc	
		Hsync	Thswid	4	—	—	Tc	

6.1.6 Input Timing spec for QFHD, Frame Rate = 30Hz

Signal	Item	Symbol	Min.	Typ.	Max.	Unit	Note	
LVDS Clock	Frequency	$F_{clk_{in}}$ (=1/TC)	60	74.25	79	MHz	(4)	
Frame Rate	2D Mode	F_r	29	30	31	Hz	(5)	
Vertical Active	2D Mode	Total	Tv	2208	2250	2450	Th	Tv=Tvd+Tvb
		Display	Tvd	2160			Th	

Display Term	Blank	Tvb	48	90	290	Th	(6)
	Front porch	Tvfp	20	—	—	Th	
	Back porch	Tvbp	20	—	—	Th	
	Vsync	Tvswid	8	—	—	Th	
Horizontal Active Display Term	Total	Th	992	1100	1340	Tc	Th=Thd+Thb
	Display	Thd	960			Tc	
	Blank	Thb	32	140	380	Tc	(6)
	Front porch	Thfp	12	—	—	Tc	
	Back porch	Thbp	10	—	—	Tc	
	Hsync	Thswid	4	—	—	Tc	

Note (1) The input clock cycle-to-cycle jitter is defined as below figures. $Trcl = |T_1 - T_2|$

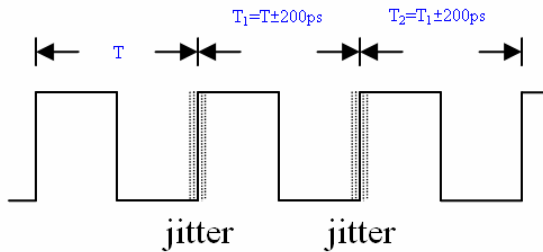

Note (2) The SSCG (Spread spectrum clock generator) is defined as below figures.

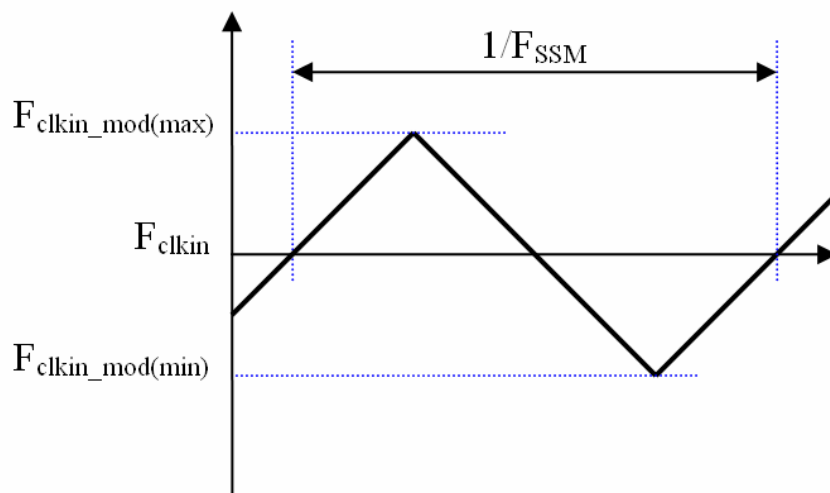

Note (3) The LVDS timing diagram and the receiver skew margin is defined and shown in following figure.

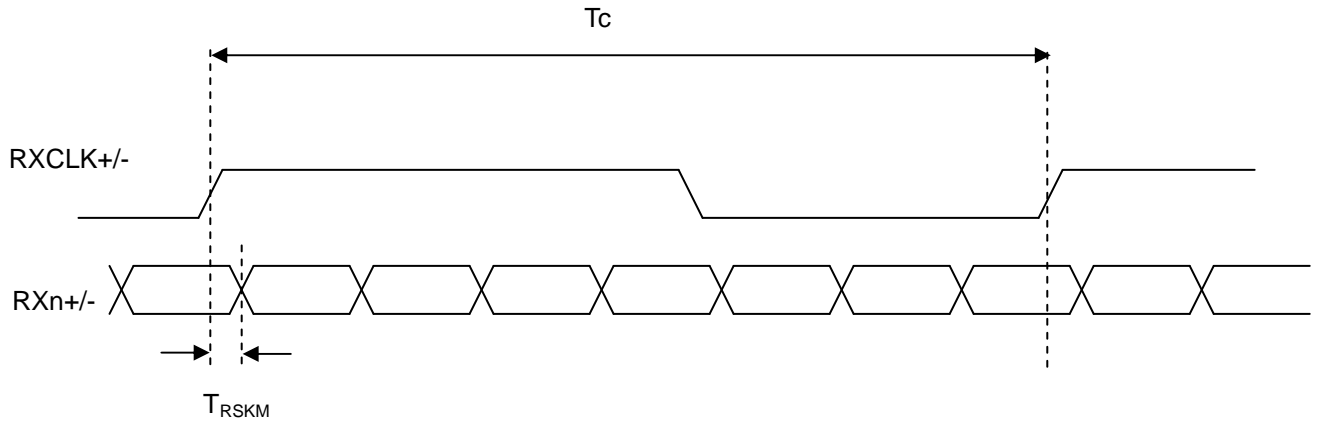

Note (4) Please make sure the range of pixel clock has follow the below equations.

$$F_{clkin}(\max) \geq (F_r \times T_v \times T_h) \geq F_{clkin}(\min)$$

Note (5)

- The frame-to-frame jitter of the input frame rate is defined as the following figure.
- $FR_n = FR_{n-1} \pm 1.8\%$.

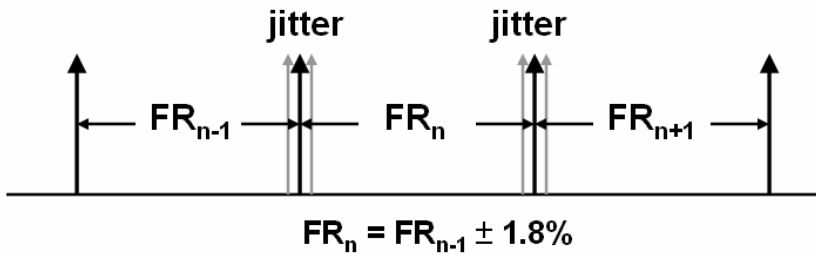

Note (6)

- Hsync and Vsync signals are necessary for this module.
- The polarity of Hsync & Vsync should be positive.
- Please follow the input signal timing diagram as below :

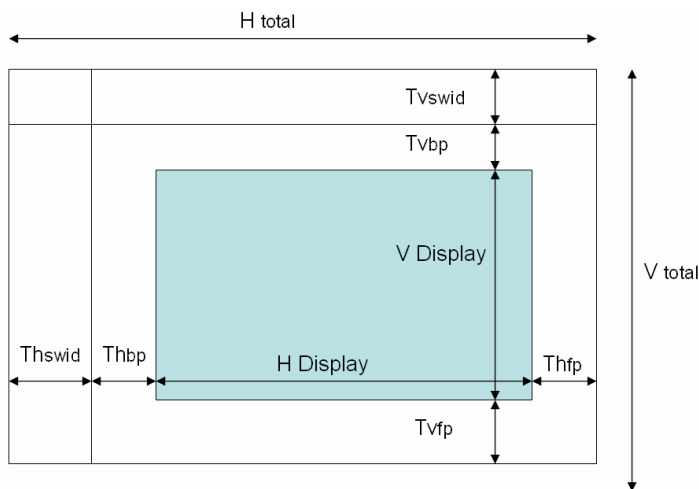

$$H \text{ blank} = H \text{ total} - H \text{ Display}$$

$$V \text{ blank} = V \text{ total} - V \text{ Display}$$

6.2 POWER ON/OFF SEQUENCE

(Ta = 25 ± 2 °C)

To prevent a latch-up or DC operation of LCD module, the power on/off sequence should be as the diagram below.

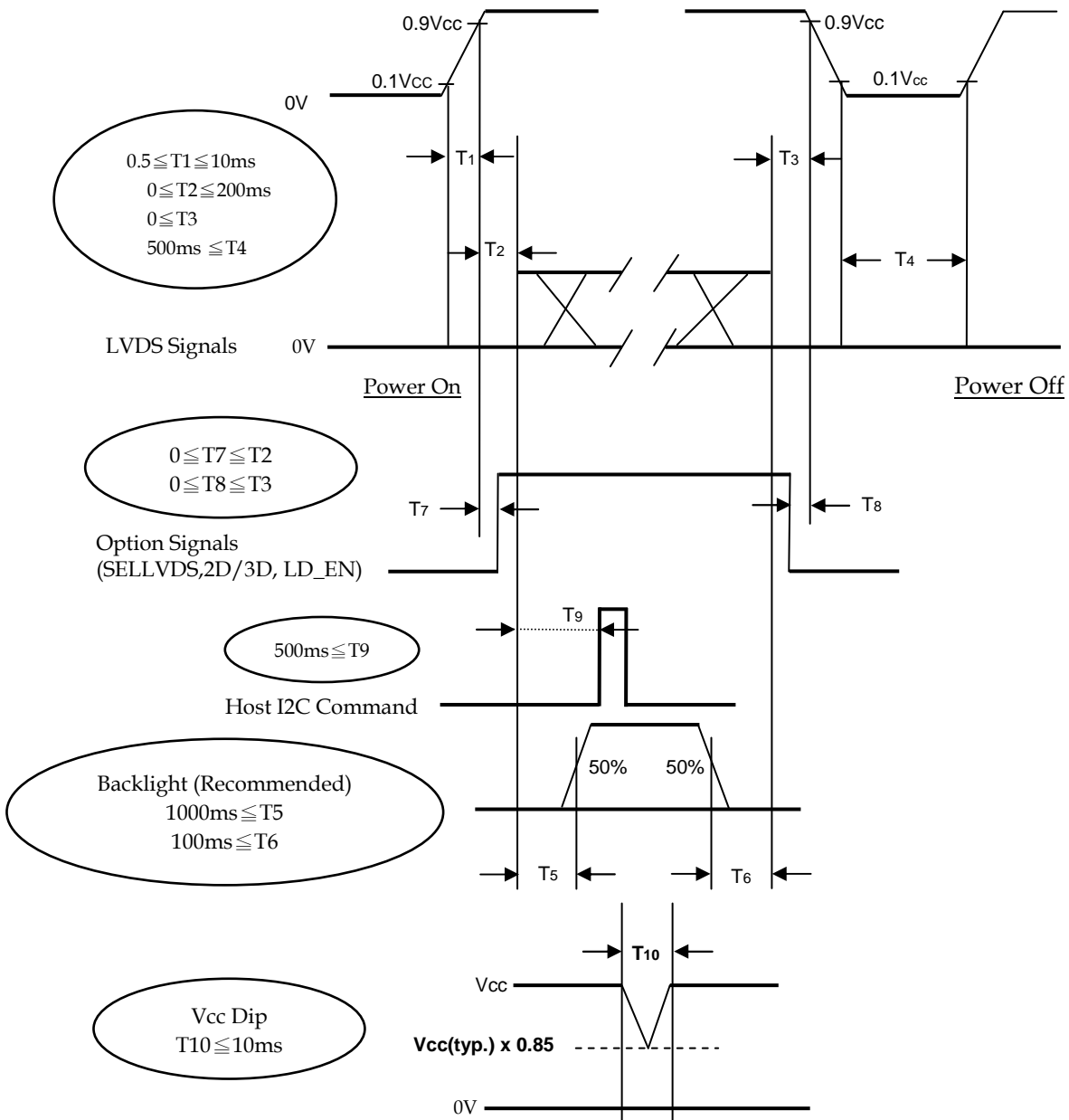

Note (1) The supply voltage of external system for the module input should follow the definition of Vcc.

Note (2) Apply the lamp voltage within the LCD operation range. When the backlight turns on before the LCD operation or the LCD turns off before the backlight turns off, the display may momentarily become abnormal screen.

Note (3) In case of VCC=off, please keep the level of input signals on the low or high impedance.

Note (4) T4 should be measured after the module has been fully discharged between power off and on period.

Note (5) Interface signal shall not be kept at high impedance when the power is on.

Note (6) Vcc must decay smoothly when power-off.

7. OPTICAL CHARACTERISTICS

7.1 TEST CONDITIONS

Item	Symbol	Value	Unit
Ambient Temperature	Ta	25±2	°C
Ambient Humidity	Ha	50±10	%RH
Supply Voltage	V _{CC}	12±1.2	V
Input Signal	According to typical value in "3. ELECTRICAL CHARACTERISTICS"		
Vertical Frame Rate	Fr	120	Hz

The LCD module should be stabilized at given temperature for 1 hour to avoid abrupt temperature change during measuring in a windless room.

Local Dimming Function should be Disable before testing to get the steady optical characteristics (According to 5.1 CNF1 Connector Pin Assignment, Pin no. "42")

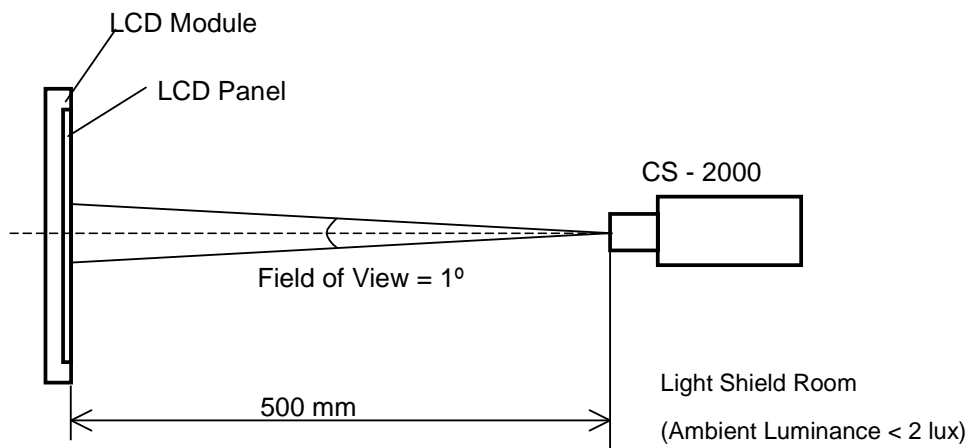

7.2 OPTICAL SPECIFICATIONS

The relative measurement methods of optical characteristics are shown in 7.2. The following items should be measured under the test conditions described in 7.1 and stable environment shown in 7.1.

Item		Symbol		Condition	Min.	Typ.	Max.	Unit	Note	
Contrast Ratio		CR		$\theta_x=0^\circ, \theta_y=0^\circ$ Viewing angle at normal direction	3500	5000	-	-	Note (2)	
Response Time		Gray to gray				6.5	13	ms	Note (3)	
Center Luminance of White	L _c	2D			280	350	-	cd/m ²	Note (4)	
		3D				60	-	cd/m ²	Note (8)	
White Variation		δW					1.3	-	Note (6)	
Cross Talk	CT	2D			-		4	%	Note (5)	
		3D-W				4	-	%	Note (8)	
		3D-D				11	-	%	Note (8)	
Color Chromaticity	Red	R _x			$\theta_x=0^\circ, \theta_y=0^\circ$ Viewing angle at normal direction	Typ.- 0.03	Typ.+ 0.03	-	-	
		R _y						0.639		
	Green	G _x		0.334				-		
		G _y		0.312				-		
	Blue	B _x		0.615				-		
		B _y		0.151				-		
	White	W _x		0.058				-		
		W _y		0.280				-		
	Correlated color temperature							0.290		
Color Gamut		C.G.		-	72	-	%	NTSC		
Viewing Angle	Horizontal	θ_{x+}		CR≥20	80	88	-	Deg.	(1)	
		θ_{x-}								
	Vertical	θ_{y+}								
		θ_{y-}								
Transmission direction of the up polarizer		Φ_{up}		-	-	90	-	Deg.	(7)	

Note (1) Definition of Viewing Angle (θ_x, θ_y) :

Viewing angles are measured by Autronic Conoscope Cono-80 (or Eldim EZ-Contrast 160R).

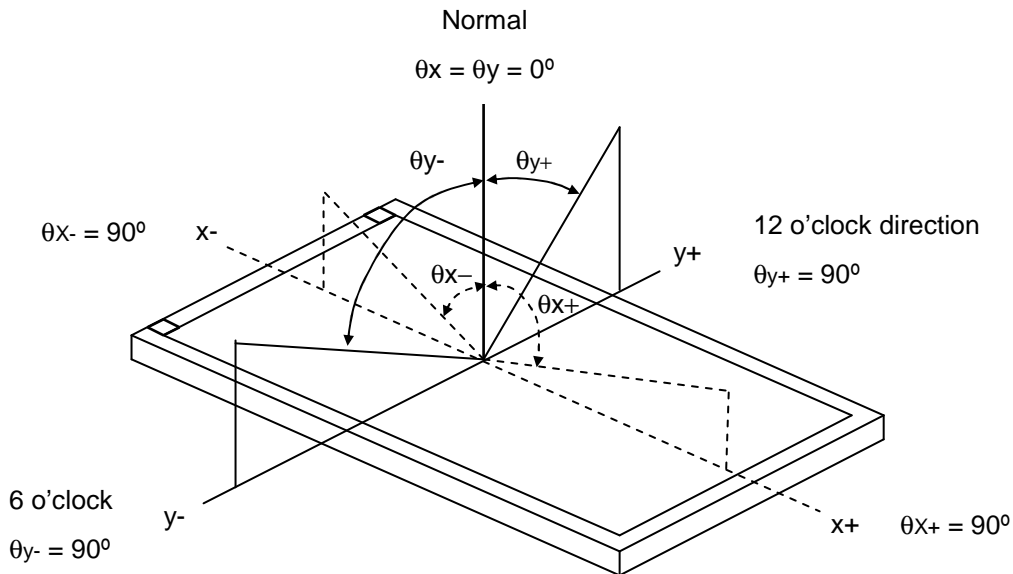

Note (2) Definition of Contrast Ratio (CR) :

The contrast ratio can be calculated by the following expression.

$$\text{Contrast Ratio (CR)} = \frac{\text{Surface Luminance of L1023}}{\text{Surface Luminance of L0}}$$

L1023: Luminance of gray level 1023

L 0: Luminance of gray level 0

CR = CR (X), where CR (X) is corresponding to the Contrast Ratio of the point X at the figure in Note (6).

Note (3) Definition of Gray-to-Gray Switching Time :

Optical Response

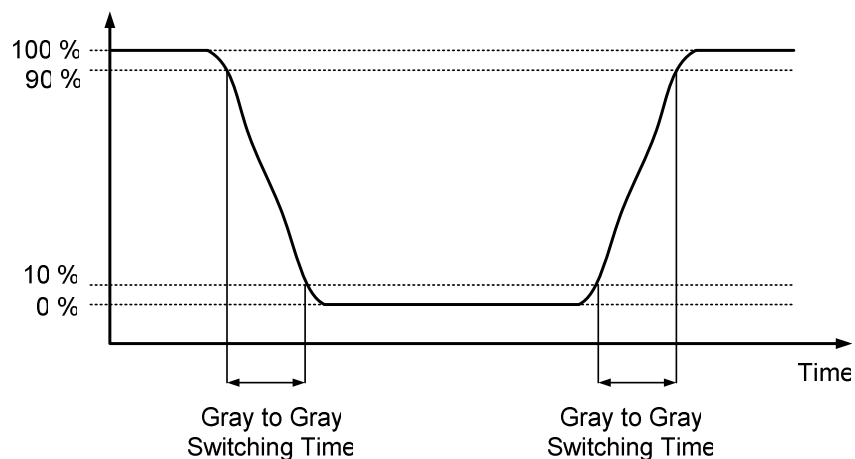

The driving signal means the signal of gray level 0, 124, 252, 380, 508, 636, 764, 892 and 1023.

Gray to gray average time means the average switching time of gray level 0, 124, 252, 380, 508, 636, 764, 892 and 1023 to each other.

Note (4) Definition of Luminance of White (L_C) :

Measure the luminance of gray level 1023 at center point.

$L_C = L(5)$, where $L(x)$ is corresponding to the luminance of the point X at the figure in Note (6).

Note (5) Definition of Cross Talk (CT) :

$$CT = |Y_B - Y_A| / Y_A \times 100 (\%)$$

Where :

Y_A = Luminance of measured location without gray level 1023 pattern (cd/m²)

Y_B = Luminance of measured location with gray level 1023 pattern (cd/m²)

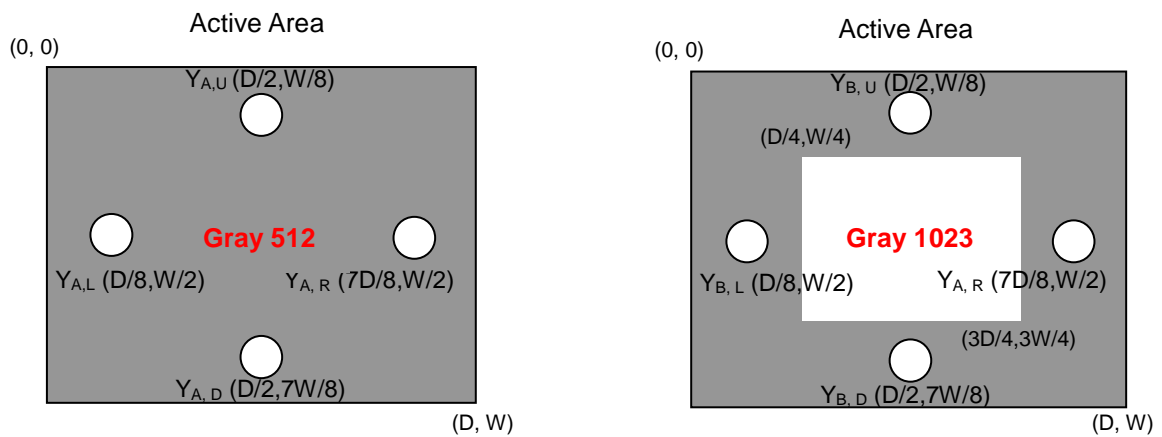

Note (6) Definition of White Variation (δW):

Measure the luminance of gray level 1023 at 5 points

$$\delta W = \frac{\text{Maximum } [L(1), L(2), L(3), L(4), L(5)]}{\text{Minimum } [L(1), L(2), L(3), L(4), L(5)]}$$

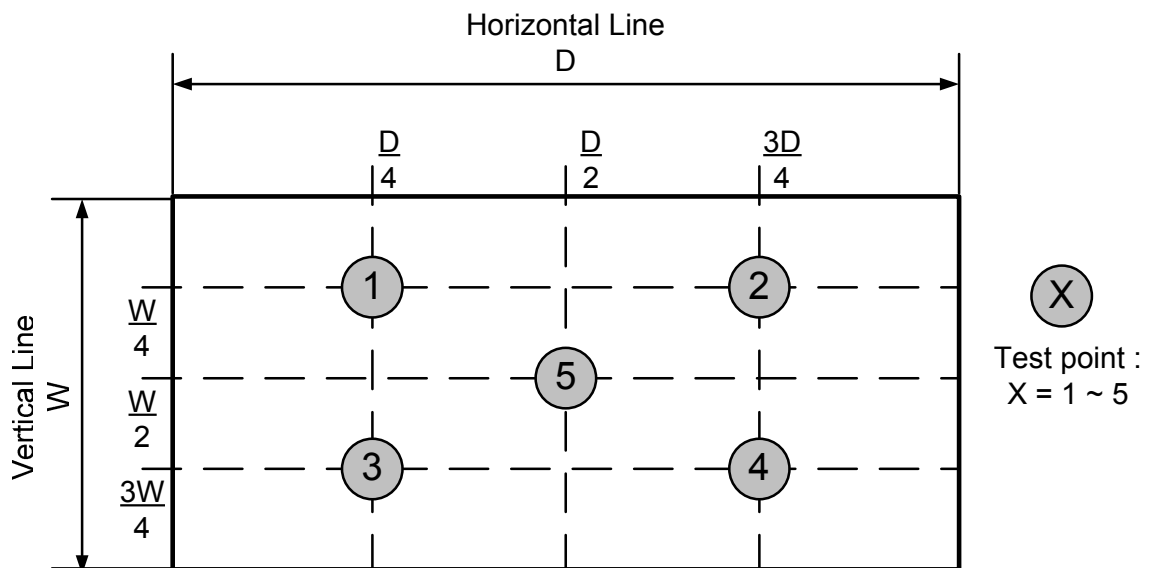

Note (7) This is a reference for designing the shutter glasses of 3D application. Definition of the transmission direction of the up polarizer (Φ_{up-P}) on LCD Module :

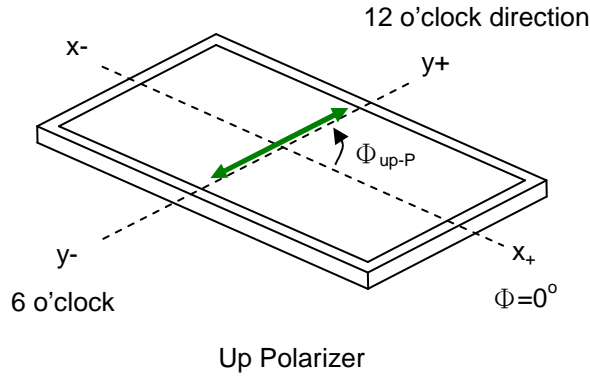

The transmission axis of the front polarizer of the shutter glasses should be parallel to this panel transmission direction to get a maximum 3D mode luminance.

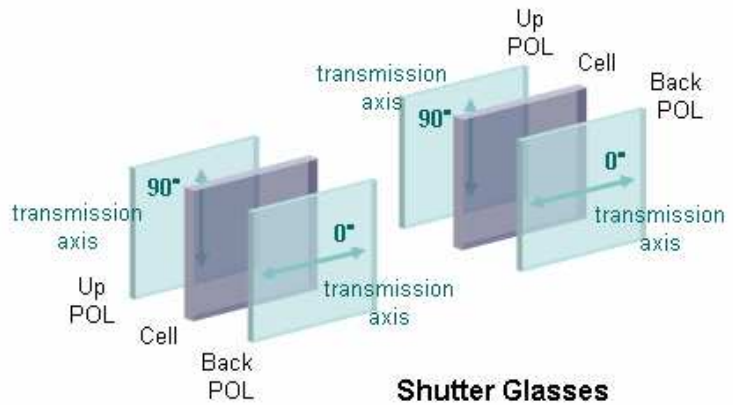
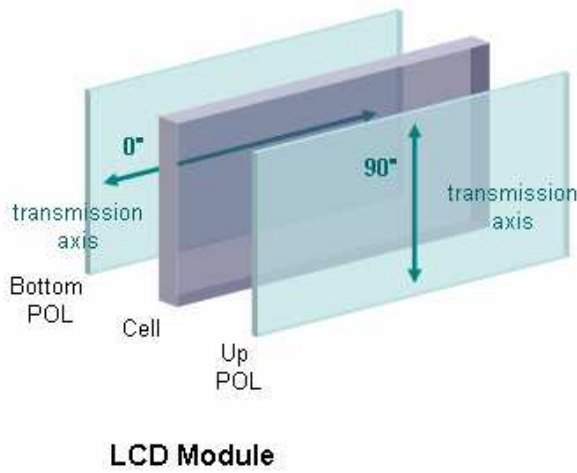

Note (8) Definition of the 3D mode performance (measured under 3D mode, use INX's shutter glass) :

a. Test pattern

Left eye image and right eye image are displayed alternated

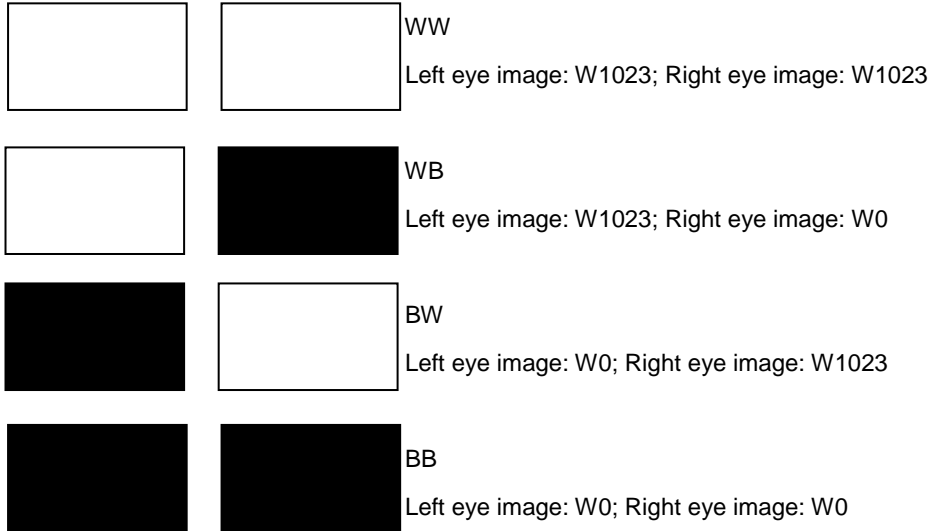

b. Measurement setup

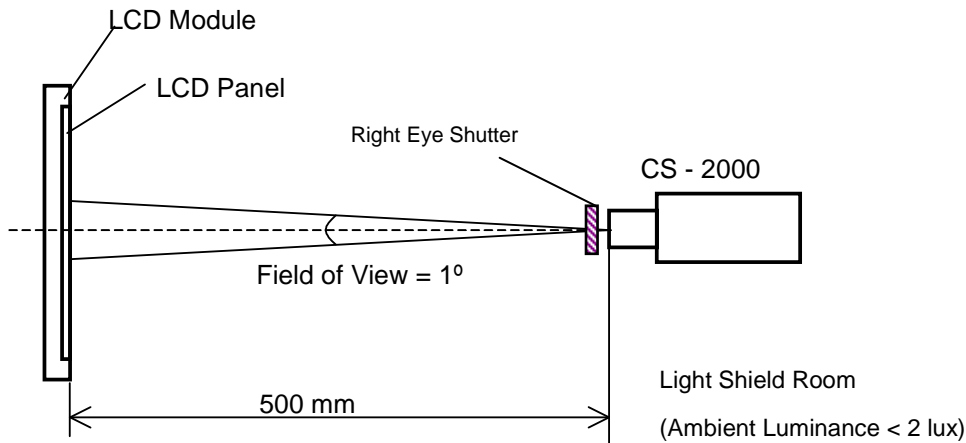

Shutter glasses are well controlled under suitable timing, and measure the luminance of the center point of the panel through the right eye glass. The transmittance of the glass should be larger than 40.0% under 3D mode operation. The luminance of the test pattern "WW", denoted L(WW); the luminance of the test pattern "WB", denoted L(WB) ; the luminance of the test pattern "BW", denoted L(BW); the luminance of the test pattern "BB", denoted "L(BB)

c. Definition of the Center Luminance of White, Lc (3D) : L(WW)

d. Definition of the 3D mode white crosstalk, CT (3D-W) : $CT(3D - W) \equiv \frac{L(WB) - L(BB)}{L(WW) - L(BB)}$

e. Definition of the 3D mode dark crosstalk, CT (3D-D) : $CT(3D - D) \equiv \frac{L(WW) - L(BW)}{L(WW) - L(BB)}$

8. PRECAUTIONS

8.1 ASSEMBLY AND HANDLING PRECAUTIONS

- (1) Do not apply rough force such as bending or twisting to the module during assembly.
- (2) It is recommended to assemble or to install a module into the user's system in clean working areas. The dust and oil may cause electrical short or worsen the polarizer.
- (3) Do not apply pressure or impulse to the module to prevent the damage of LCD panel and backlight.
- (4) Always follow the correct power-on sequence when the LCD module is turned on. This can prevent the damage and latch-up of the CMOS LSI chips.
- (5) Do not plug in or pull out the I/F connector while the module is in operation.
- (6) Do not disassemble the module.
- (7) Use a soft dry cloth without chemicals for cleaning, because the surface of polarizer is very soft and easily scratched.
- (8) Moisture can easily penetrate into LCD module and may cause the damage during operation.
- (9) High temperature or humidity may deteriorate the performance of LCD module. Please store LCD modules in the specified storage conditions.
- (10) When ambient temperature is lower than 10°C, the display quality might be reduced. For example, the response time will become slow, and the starting voltage of LED will be higher than that of room temperature.

8.2 SAFETY PRECAUTIONS

- (1) The startup voltage of a backlight is over 1000 Volts. It may cause an electrical shock while assembling with the inverter. Do not disassemble the module or insert anything into the backlight unit.
- (2) If the liquid crystal material leaks from the panel, it should be kept away from the eyes or mouth. In case of contact with hands, skin or clothes, it has to be washed away thoroughly with soap.
- (3) After the module's end of life, it is not harmful in case of normal operation and storage.

8.3 SAFETY STANDARDS

The LCD module should be certified with safety regulations as follows:

Regulatory	Item	Standard
Information Technology equipment	UL	UL60950-1 Ed.2:2007
	cUL	CAN/CSA C22.2 No. 60950-1-07
	CB	IEC60950-1:2005+ A1:2009 EN60950-1:2006+ A11:2009+ A1:2010+ A12:2011
Audio/Video Apparatus	UL	UL60065 Ed.7:2007
	cUL	CAN/CSA C22.2 No.60065-03:2006 + A1:2006
	CB	IEC60065:2001+ A1:2005+ A2:2010 EN60065:2002 + A1:2006+ A11:2008 +A2:2010+ A12:2011

If the module displays the same pattern for a long period of time, the phenomenon of image sticking may be occurred.

9. DEFINITION OF LABELS

9.1 INX MODULE LABEL

The barcode nameplate is pasted on each module as illustration, and its definitions are as following explanation.



Model Name : V420DK1-LS1

Revision : Rev. XX, for example: A0, A1... B1, B2... or C1, C2...etc.

Serial ID : X X X X X X Y M D L N N N N

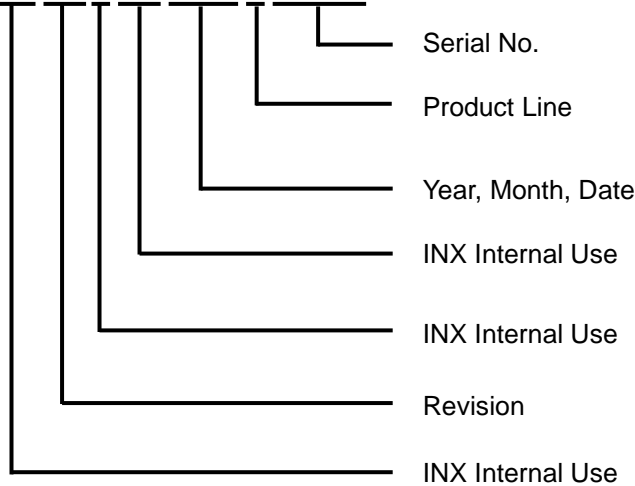

Serial ID includes the information as below:

Manufactured Date:

Year : 2001=1, 2002=2, 2003=3, 2004=4...2010=0, 2011=1, 2012=2...

Month: 1~9, A~C, for Jan. ~ Dec.

Day: 1~9, A~Y, for 1st to 31st, exclude I ,O, and U.

Revision Code : Cover all the change

Serial No. : Manufacturing sequence of product

Product Line : 1→Line1, 2→Line 2, ...etc.

9.2 CARTON LABEL

The barcode nameplate is pasted on each box as illustration, and its definitions are as following explanation.

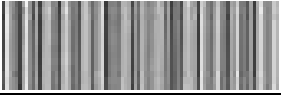
P.O. NO.	_____
Parts ID.	_____
Model Name	V420DK1-LS1 _____
Carton ID.	 _____ Quantities _____ XXXXXXXXXXXXXXXX
Made In Taiwan (Made In China)	

Model Name: V420DK1- LS1

Carton ID: X X X X X X Y M D X X X X

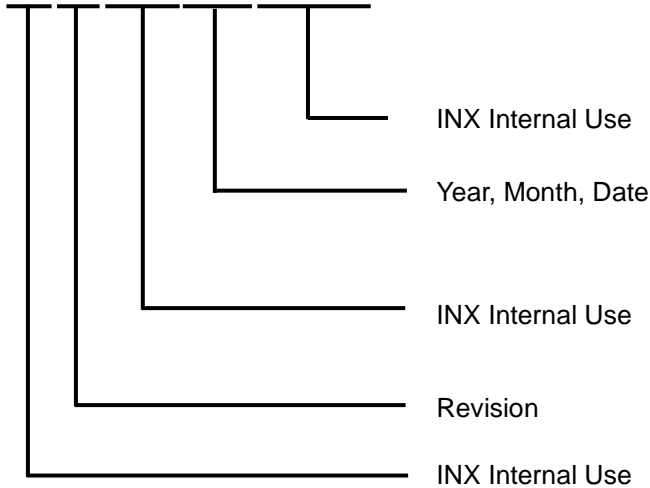

Serial ID includes the information as below :

Manufactured Date:

Year: 2010=0, 2011=1, 2012=2...etc.

Month: 1~9, A~C, for Jan. ~ Dec.

Day: 1~9, A~Y, for 1st to 31st, exclude I ,O, and U.

Revision Code: Cover all the change

10. PACKAGING

10.1 PACKAGING SPECIFICATIONS

- (1) 6 LCD TV modules / 1 Box
- (2) Box dimensions : 1035(L) X 309 (W) X 625 (H)
- (3) Weight: approximately 48 Kg (modules per box)

10.2 PACKAGING METHOD

Packaging method is shown in following figures.

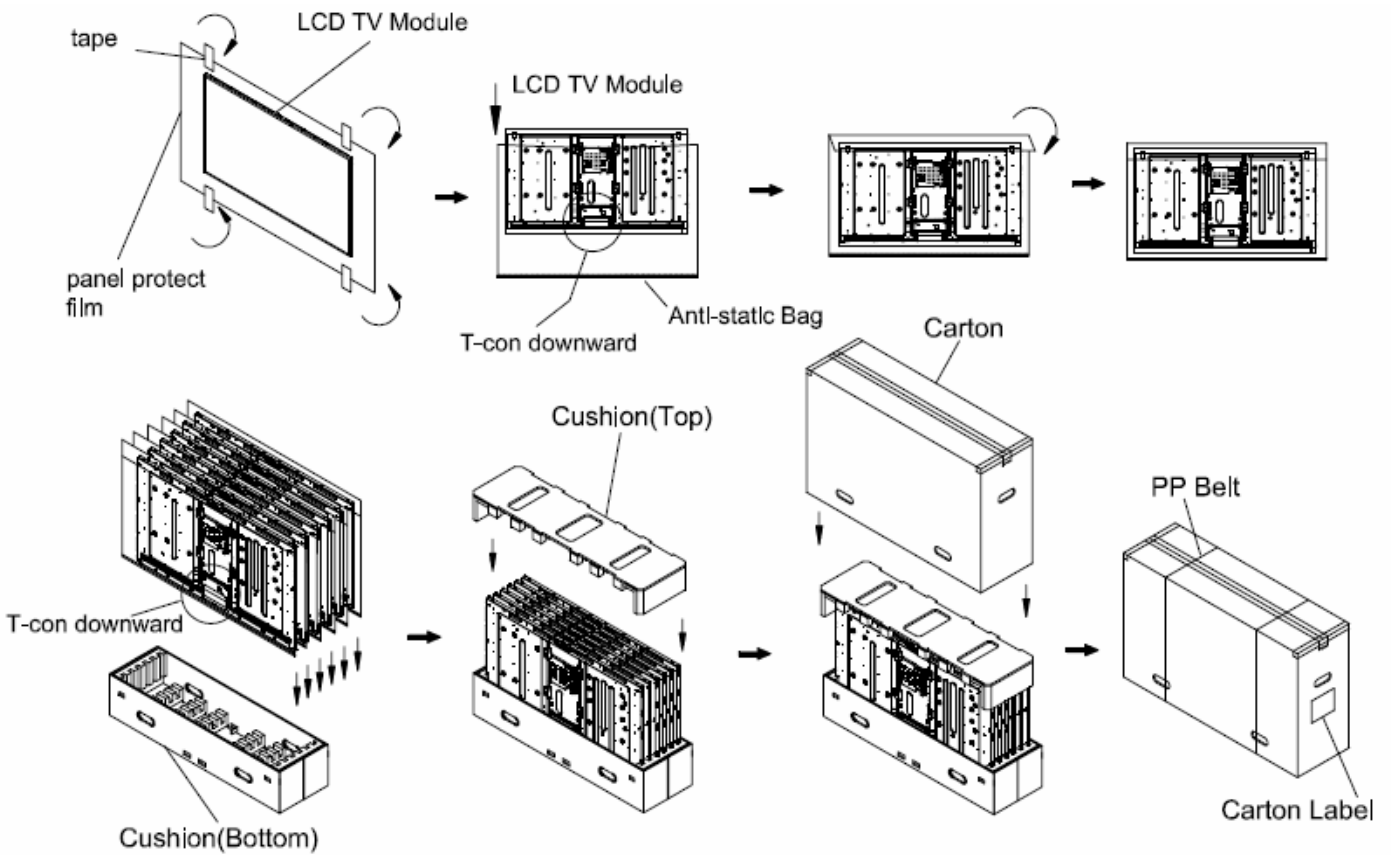

Sea / Land Transportatlon
(40ft & 40ft HQ Container)

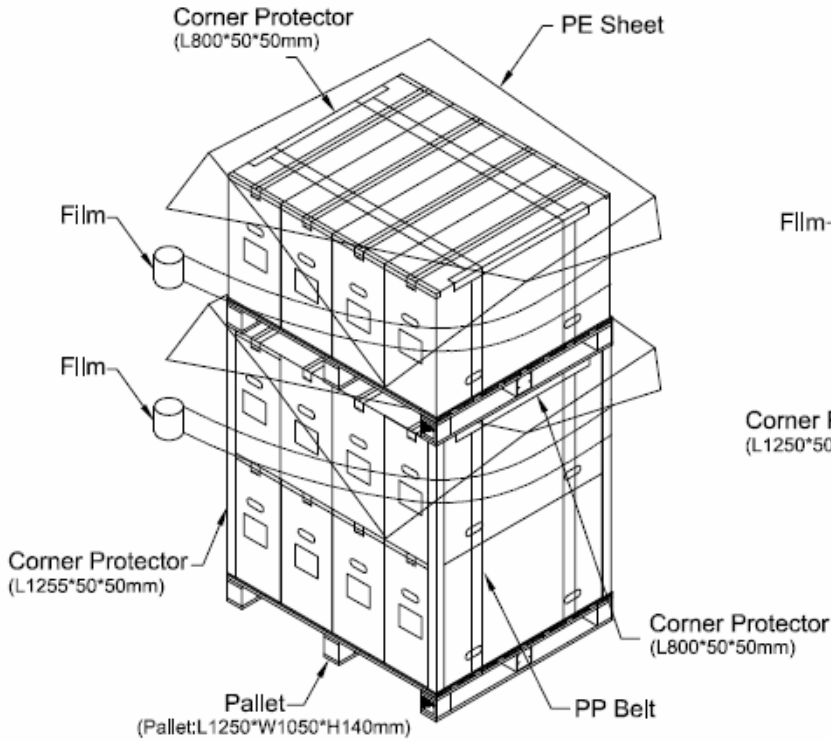

Air Transportatlon

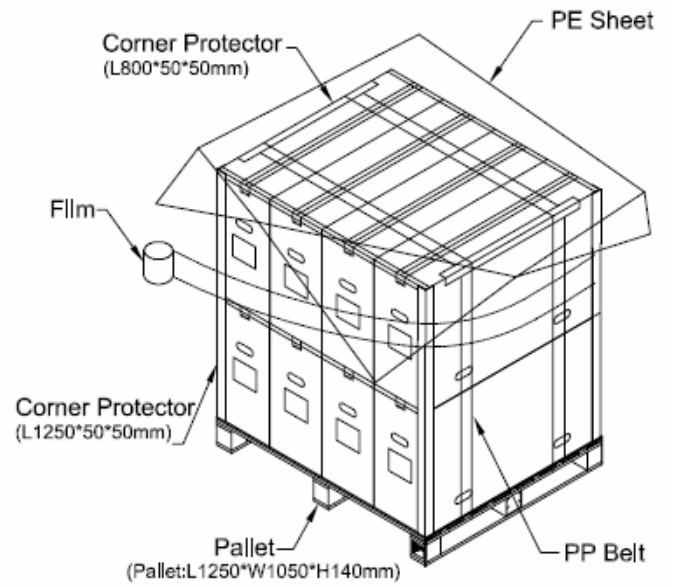

10.3 UN-PACKAGING METHOD

Un-packaging method is shown as following figures.

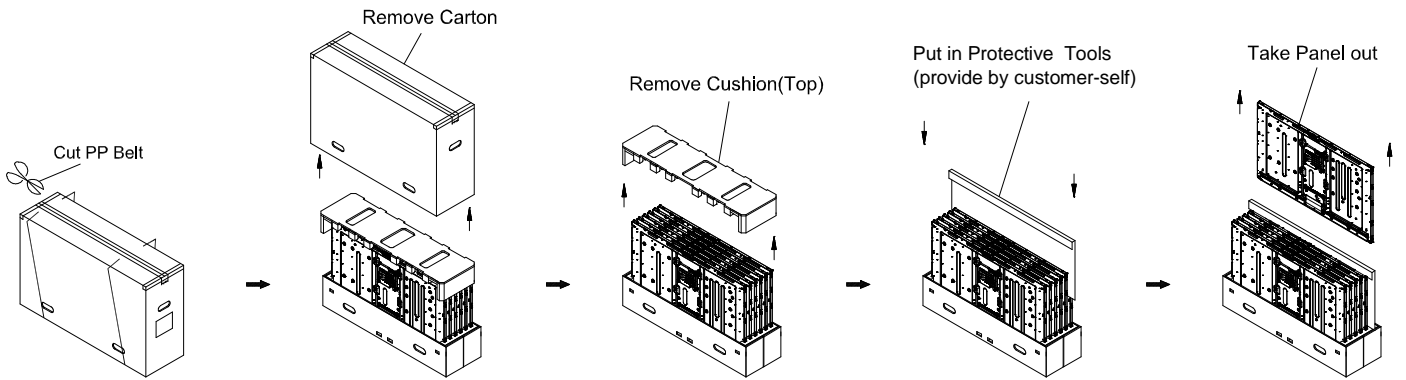

11. MECHANICAL CHARACTERISTIC

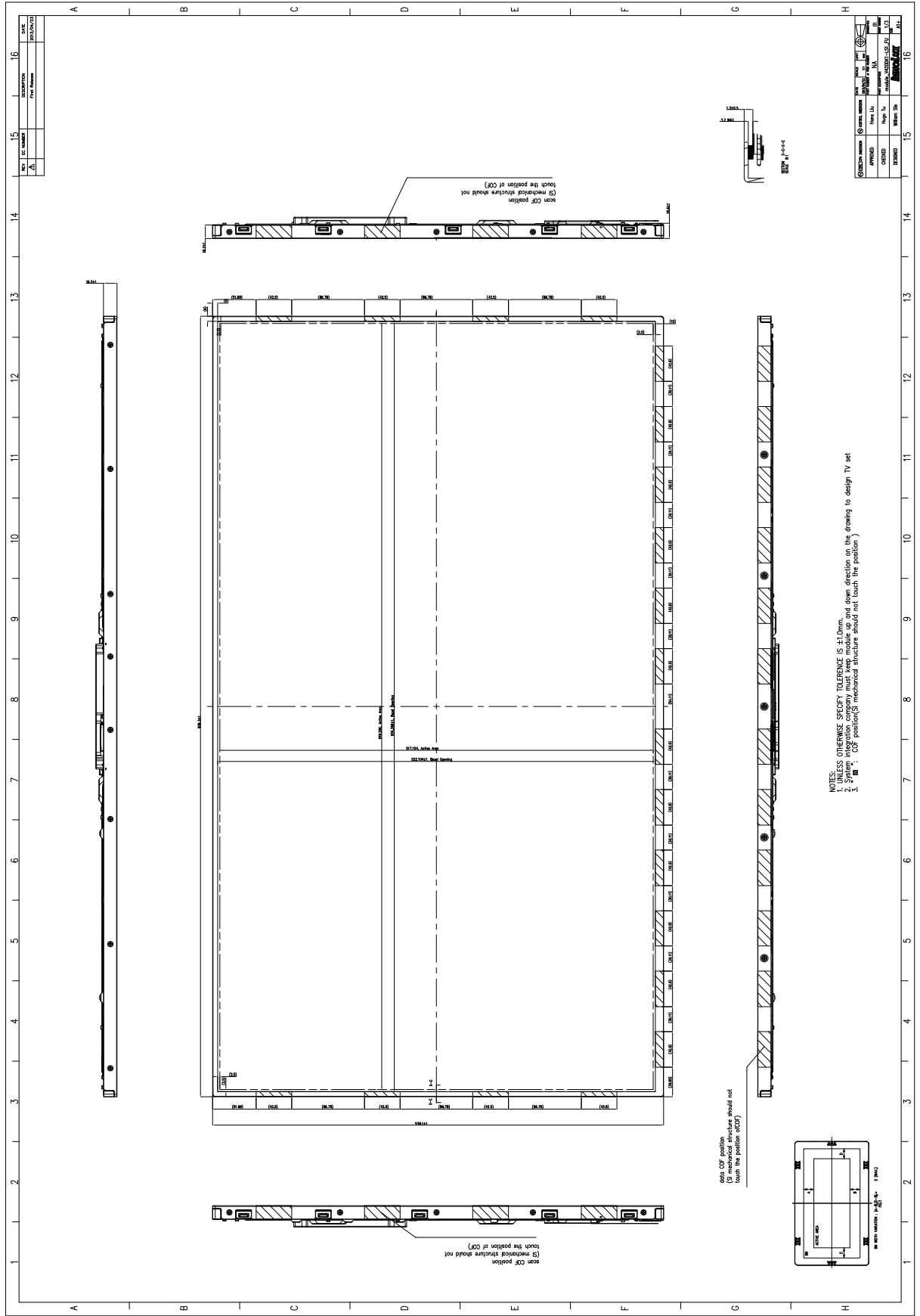

NOTES:
 1. UNLESS OTHERWISE SPECIFY TOLERANCE IS ± 1.0 mm.
 2. System integration company must keep module up and down direction on this drawing to design TV set.
 3. [S] : COP position (S) mechanical structure should not touch the position.

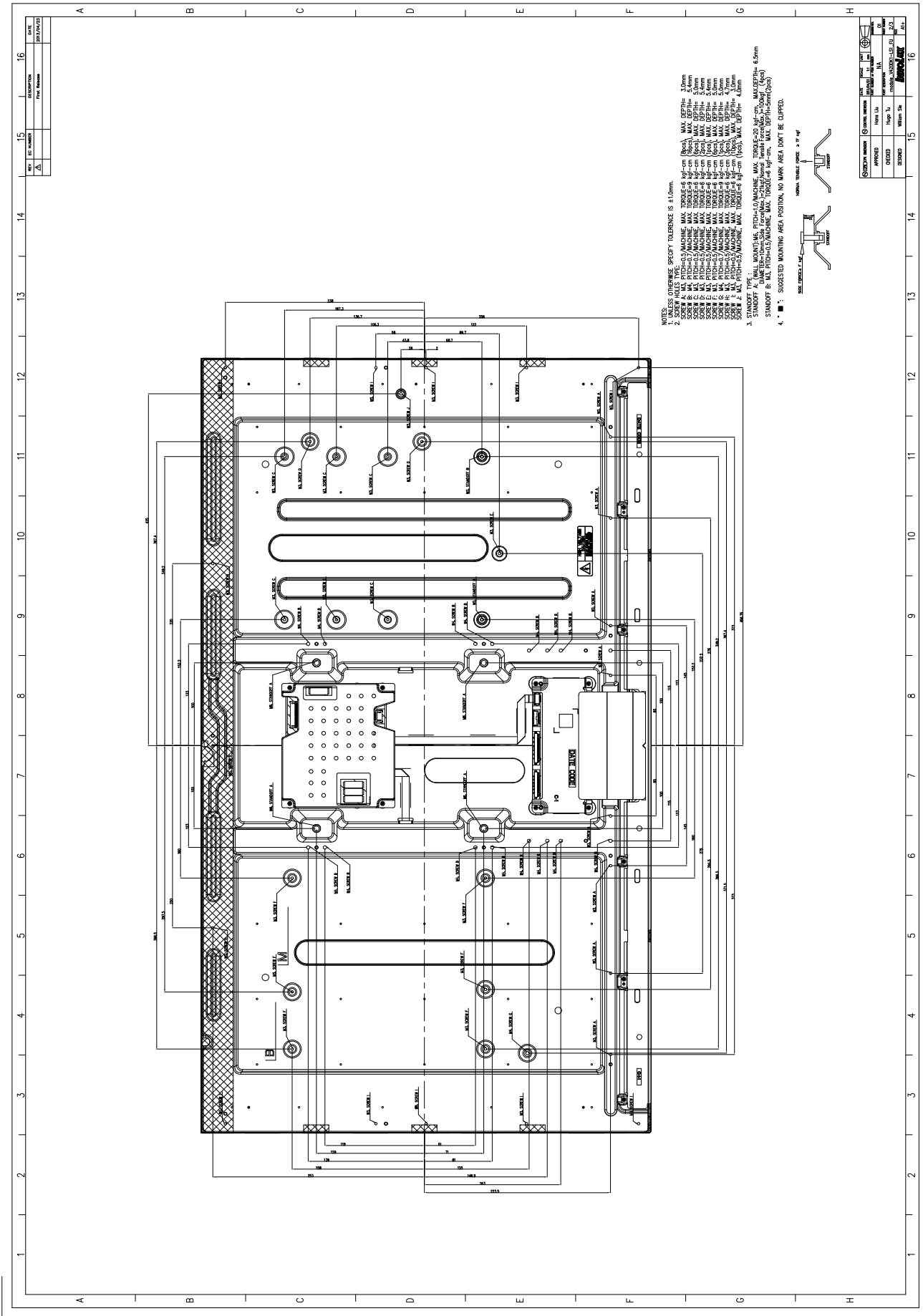

- NOTES:
- SIZES AND DIMENSIONS SPECIFY TOLERANCE IS ±0.1mm.
 - SCREW A: ALL PITCHES/MACHINE MAX. TORQUE=48 kgf-cm (4800g)
SCREW B: ALL PITCHES/MACHINE MAX. TORQUE=48 kgf-cm (4800g)
SCREW C: ALL PITCHES/MACHINE MAX. TORQUE=48 kgf-cm (4800g)
SCREW D: ALL PITCHES/MACHINE MAX. TORQUE=48 kgf-cm (4800g)
SCREW E: ALL PITCHES/MACHINE MAX. TORQUE=48 kgf-cm (4800g)
SCREW F: ALL PITCHES/MACHINE MAX. TORQUE=48 kgf-cm (4800g)
SCREW G: ALL PITCHES/MACHINE MAX. TORQUE=48 kgf-cm (4800g)
SCREW H: ALL PITCHES/MACHINE MAX. TORQUE=48 kgf-cm (4800g)
 - STANDOFF A: SMALL MOUNTING PITCH=20 kgf-cm, MAX DEPTH=6.5mm
STANDOFF B: SMALL MOUNTING PITCH=20 kgf-cm, MAX DEPTH=6.5mm
STANDOFF C: SMALL MOUNTING PITCH=20 kgf-cm, MAX DEPTH=6.5mm
STANDOFF D: SMALL MOUNTING PITCH=20 kgf-cm, MAX DEPTH=6.5mm
 - ★ SUGGESTED MOUNTING AREA POSITION, NO MARK AREA DON'T BE CUTTED.



REVISION	DATE	DESCRIPTION
16	2013/07/23	GROUP DESIGN
15		GROUP DESIGN
14		GROUP DESIGN
13		GROUP DESIGN
12		GROUP DESIGN
11		GROUP DESIGN
10		GROUP DESIGN
9		GROUP DESIGN
8		GROUP DESIGN
7		GROUP DESIGN
6		GROUP DESIGN
5		GROUP DESIGN
4		GROUP DESIGN
3		GROUP DESIGN
2		GROUP DESIGN
1		GROUP DESIGN

