

TFT LCD Preliminary Specification

MODEL NO.: V420H1 – LH4

Customer: _____
Approved by: _____
Note:

Approved By	TV Head Division	
	LY Chen	

Reviewed By	QRA Dept.	Product Development Div.
	Tomy Chen	WT Lin

Prepared By	LCD TV Marketing and Product Management Div.	
	Ken Wu	CY Chang

CONTENTS

REVISION HISTORY.....	4
1. GENERAL DESCRIPTION.....	5
1.1 OVERVIEW.....	5
1.2 FEATURES.....	5
1.3 APPLICATION.....	5
1.4 GENERAL SPECIFICATIONS.....	5
1.5 MECHANICAL SPECIFICATIONS.....	6
2. ABSOLUTE MAXIMUM RATINGS.....	7
2.1 ABSOLUTE RATINGS OF ENVIRONMENT.....	7
2.2 PACKAGE STORAGE.....	7
2.3 ELECTRICAL ABSOLUTE RATINGS.....	8
2.3.1 TFT LCD MODULE.....	8
2.3.2 BACKLIGHT INVERTER UNIT.....	8
3. ELECTRICAL CHARACTERISTICS.....	9
3.1 TFT LCD MODULE.....	9
3.2 BACKLIGHT CONNECTOR PIN CONFIGURATION.....	11
3.2.1 LAMP SPECIFICATION.....	11
3.2.2 ELECTRICAL SPECIFICATION.....	11
3.2.3 INVERTER INTERFACE CHARACTERISTICS.....	13
4. BLOCK DIAGRAM OF INTERFACE.....	15
4.1 TFT LCD MODULE.....	15
5. INPUT TERMINAL PIN ASSIGNMENT.....	16
5.1 TFT LCD Module Input.....	16
5.2 BACKLIGHT UNIT.....	20
5.3 INVERTER UNIT.....	20
5.4 BLOCK DIAGRAM OF INTERFACE.....	22
5.5 LVDS INTERFACE.....	24
5.5 COLOR DATA INPUT ASSIGNMENT.....	25
6. INTERFACE TIMING.....	26
6.1 INPUT SIGNAL TIMING SPECIFICATIONS.....	26

6.2 POWER ON/OFF SEQUENCE.....	28
7. OPTICAL CHARACTERISTICS	30
7.1 TEST CONDITIONS.....	30
7.2 OPTICAL SPECIFICATIONS	31
8. PRECAUTIONS.....	34
8.1 ASSEMBLY AND HANDLING PRECAUTIONS	34
8.2 SAFETY PRECAUTIONS	34
9. DEFINITION OF LABELS.....	35
9.1 CMO MODULE LABEL	35
10. PACKAGING.....	36
10.1 PACKAGING SPECIFICATIONS	36
10.2 PACKAGING METHOD.....	36
11. MECHANICAL CHARACTERISTICS	38

REVISION HISTORY

Version	Date	Page (New)	Section	Description
Ver.1.0	Jun, 25,'08	All	All	Preliminary Specification was first issued.

1. GENERAL DESCRIPTION

1.1 OVERVIEW

V420H1-LH4 is a 42" TFT Liquid Crystal Display module with 24-CCFL Backlight unit and 4ch-LVDS interface.

This module supports 1920 x 1080 Full HDTV format and can display true 1.07G colors (10-bit/color). The inverter module for backlight is built-in.

1.2 FEATURES

- High brightness (500 nits)
- High contrast ratio (4000:1)
- Fast response time (Gray to gray average 4.0 ms)
- High color saturation (NTSC 92%)
- Full HDTV (1920 x 1080 pixels) resolution, true HDTV format
- DE (Data Enable) only mode
- LVDS (Low Voltage Differential Signaling) interface
- Optimized response time for 120 Hz frame rate
- Ultra wide viewing angle : Super MVA technology
- RoHS compliance

1.3 APPLICATION

- Standard Living Room TVs.
- Public Display Application.
- Home Theater Application.
- MFM Application.

1.4 GENERAL SPECIFICATIONS

Item	Specification	Unit	Note
Active Area	930.24(H) x 523.26 (V) (42.02" diagonal)	mm	(1)
Bezel Opening Area	937.24 (H) x 530.26 (V)	mm	
Driver Element	a-si TFT active matrix	-	-
Pixel Number	1920 x R.G.B. x 1080	pixel	-
Pixel Pitch(Sub Pixel)	0.1615 (H) x 0.4845 (V)	mm	-
Pixel Arrangement	RGB vertical stripe	-	-
Display Colors	1.07G	color	-
Display Operation Mode	Transmissive mode / Normally black	-	-
Surface Treatment	Hot Coating Low Reflection	-	(2)

Note (1) Please refer to the attached drawings in chapter 9 for more information about the front and back outlines.

Note (2) The spec. of the surface treatment is temporarily for this phase. CMO reserves the rights to change this feature.

1.5 MECHANICAL SPECIFICATIONS

Item		Min.	Typ.	Max.	Unit	Note
Module Size	Horizontal (H)	-	957.24	-	mm	(1), (2)
	Vertical (V)	-	550.26	-	mm	
	Depth (D)	-	32.0	-	mm	
Weight		-	11600	-	g	-

Note (1) Please refer to the attached drawings for more information of front and back outline dimensions.

Note (2) Module Depth is between bezel to T-CON cover.

2. ABSOLUTE MAXIMUM RATINGS

2.1 ABSOLUTE RATINGS OF ENVIRONMENT

Item	Symbol	Value		Unit	Note
		Min.	Max.		
Storage Temperature	TST	-20	+60	°C	(1)
Operating Ambient Temperature	TOP	0	50	°C	(1), (2)
Shock (Non-Operating)	SNOP	-	50	G	(3), (5)
Vibration (Non-Operating)	VNOP	-	1.0	G	(4), (5)

Note (1) Temperature and relative humidity range is shown in the figure below.

- (a) 90 %RH Max. ($T_a \leq 40\text{ }^\circ\text{C}$).
- (b) Wet-bulb temperature should be 39 °C Max. ($T_a > 40\text{ }^\circ\text{C}$).
- (c) No condensation.

Note (2) The maximum operating temperature is based on the test condition that the surface temperature of display area is less than or equal to 65 °C with LCD module alone in a temperature controlled chamber. Thermal management should be considered in final product design to prevent the surface temperature of display area from being over 65 °C. The range of operating temperature may degrade in case of improper thermal management in final product design.

Note (3) 11 ms, half sine wave, 1 time for $\pm X$, $\pm Y$, $\pm Z$.

Note (4) 10 ~ 200 Hz, 10 min, 1 time each X, Y, Z.

Note (5) At testing Vibration and Shock, the fixture in holding the module has to be hard and rigid enough so that the module would not be twisted or bent by the fixture.

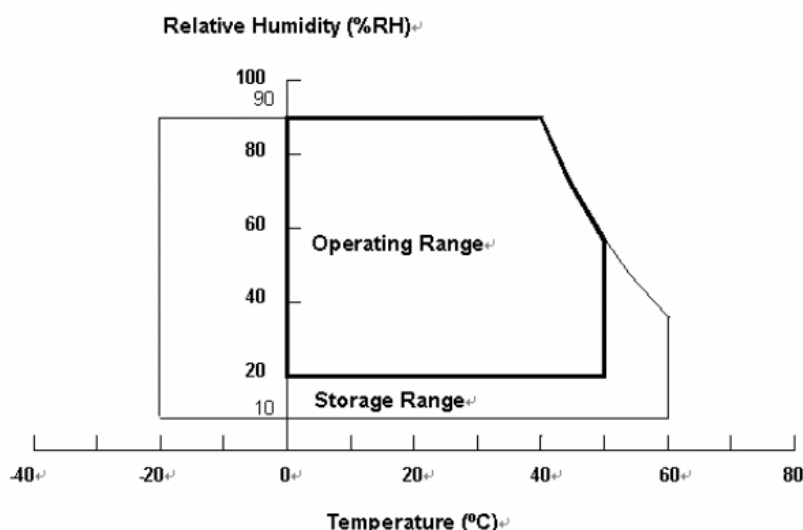

2.2 PACKAGE

STORAGE

When storing modules as spares for a long time, the following precaution is necessary.

- (a) Do not leave the module in high temperature, and high humidity for a long time, It is highly recommended to store the module with temperature from 0 to 35 °C at normal humidity without condensation.
- (b) The module shall be stored in dark place. Do not store the TFT-LCD module in direct sunlight or fluorescent

light.

2.3 ELECTRICAL ABSOLUTE RATINGS

2.3.1 TFT LCD MODULE

Item	Symbol	Value		Unit	Note
		Min.	Max.		
Power Supply Voltage	VCC	-0.3	13.5	V	(1)
Logic Input Voltage	VIN	-0.3	3.6	V	

2.3.2 BACKLIGHT INVERTER UNIT

Item	Symbol	Value		Unit	Note
		Min.	Max.		
Lamp Voltage	VW	—	3000	VRMS	
Power Supply Voltage	VBL	0	30	V	(1)
Control Signal Level	—	-0.3	7	V	(1), (3)

Note (1) Permanent damage to the device may occur if maximum values are exceeded. Function operation should be restricted to the conditions described under Normal Operating Conditions.

Note (2) No moisture condensation or freezing.

Note (3) The control signals include On/Off Control and Internal PWM Control.

3. ELECTRICAL CHARACTERISTICS

3.1 TFT LCD MODULE

(Ta = 25 ± 2 °C)

Parameter	Symbol	Value			Unit	Note	
		Min.	Typ.	Max.			
Power Supply Voltage	VCC	10.8	12	13.2	V	(1)	
Power Supply Ripple Voltage	VRP	-	-	350	mV		
Rush Current	IRUSH	-	-	6.0	A	(2)	
Power Supply Current	White Pattern	-	-	1.6	2.0	A	(3)
	Vertical Stripe	-	-	1.5	-	A	
	Black Pattern	-	-	1.0	-	A	
LVDS interface	Common Input Voltage	VLVC	1.125	1.25	1.375	V	
	Terminating Resistor	RT	-	100	-	ohm	
CMOS interface	Input High Threshold Voltage	VIH	2.7	-	3.3	V	
	Input Low Threshold Voltage	VIL	0	-	0.7	V	

Note (1) The module should be always operated within the above ranges.

Note (2) Measurement condition:

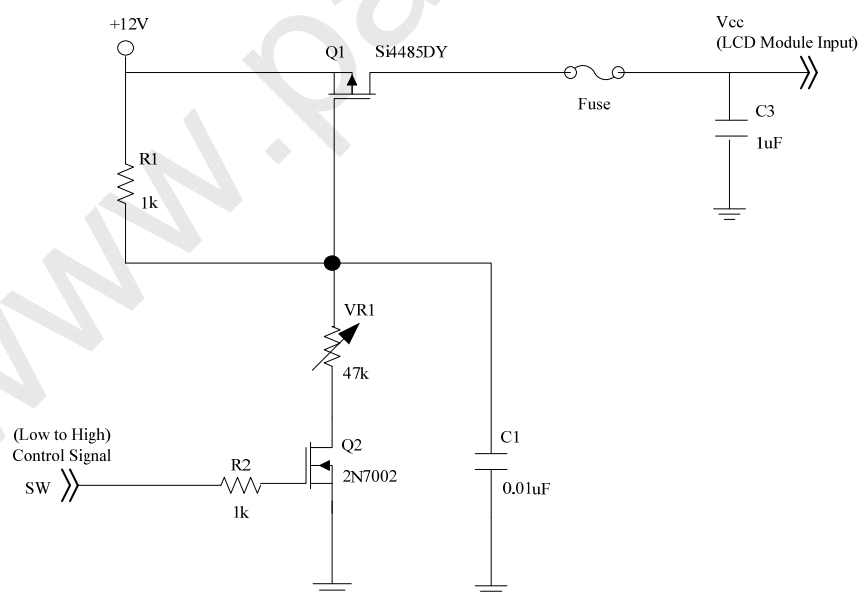

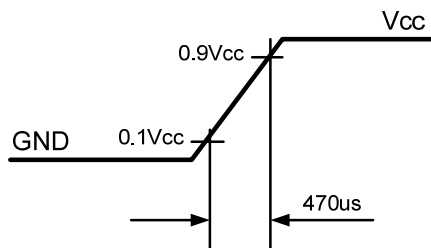
Vcc rising time is 470us

Note (3) The specified power supply current is under the conditions at $V_{cc} = 12\text{ V}$, $T_a = 25 \pm 2\text{ }^\circ\text{C}$, $f_v = 120\text{ Hz}$, whereas a power dissipation check pattern below is displayed.

a. White Pattern

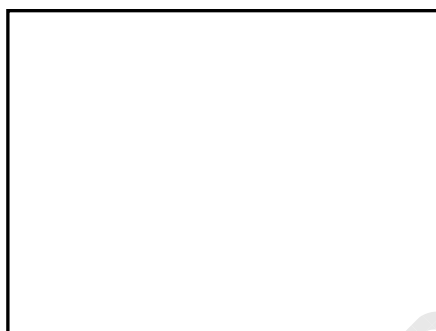

Active Area

b. Black Pattern

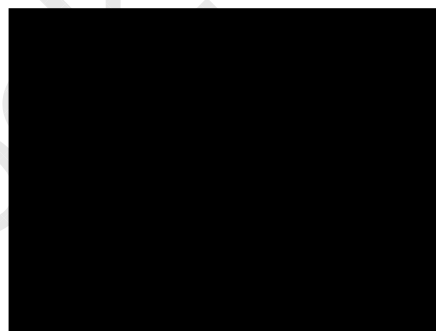

Active Area

c. Vertical Stripe Pattern

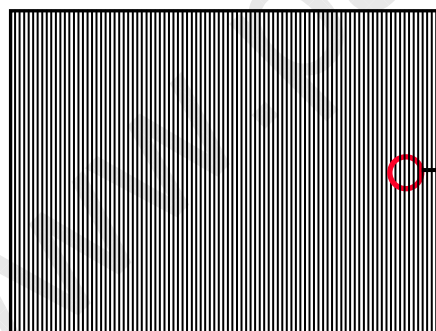

Active Area

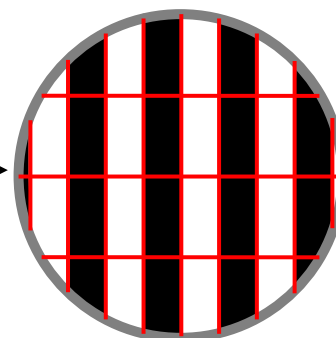

3.2 BACKLIGHT CONNECTOR PIN CONFIGURATION

3.2.1 LAMP SPECIFICATION

(Ta = 25 ± 2 °C)

Parameter	Symbol	Value			Unit	Note
		Min.	Typ.	Max.		
Lamp Input Voltage	VL	-	(1490)	-	VRMS	-
Lamp Current	IL	4.5	5.0	5.5	mARMS	(1)
Lamp Turn On Voltage	VS	-	-	(2370)	VRMS	Ta = 0 °C
		-	-	(2160)	VRMS	Ta = 25 °C
Operating Frequency	FL	40	-	70	KHz	
Lamp Life Time	LBL	50,000	60,000	-	Hrs	(2)

3.2.2 ELECTRICAL SPECIFICATION

(Ta = 25 ± 2 °C)

Parameter	Symbol	Value			Unit	Note
		Min.	Typ.	Max.		
Power Consumption	P _{BL}	-	170	-	W	(5), IL = 5.0mA
Power Supply Voltage	VBL	22.8	24.0	25.2	VDC	
Power Supply Current	IBL	-	7.1	-	A	Non Dimming
Input Ripple Noise	-	-	-	912	mVP-P	VBL=22.8V
Oscillating Frequency	FW	40	43	46	kHz	
Dimming frequency	FB	150	160	170	Hz	
Minimum Duty Ratio	DMIN	-	10	-	%	

Note (1) Lamp current is measured by utilizing AC current probe and its value is average by measuring master and slave board.

Note (2) The lamp starting voltage VS should be applied to the lamp for more than 1 second after startup. Otherwise the lamp may not be turned on.

Note (3) The lamp frequency may produce interference with horizontal synchronous frequency of the display input signals, and it may result in line flow on the display. In order to avoid interference, the lamp frequency should be detached from the horizontal synchronous frequency and its harmonics as far as possible.

Note (4) The life time of a lamp is defined as when the brightness is larger than 50% of its original value and the effective discharge length is longer than 80% of its original length (Effective discharge length is defined as an area that has equal to or more than 70% brightness compared to the brightness at the center point of lamp.) as the time in which it continues to operate under the condition at Ta = 25 ± 2°C and IL = 4.5~5.5mArms.

Note (5) The measurement condition of Max. value is based on 42" backlight unit under input voltage 24V, average lamp current 5.5 mA and lighting 30 minutes later.

Note (6)

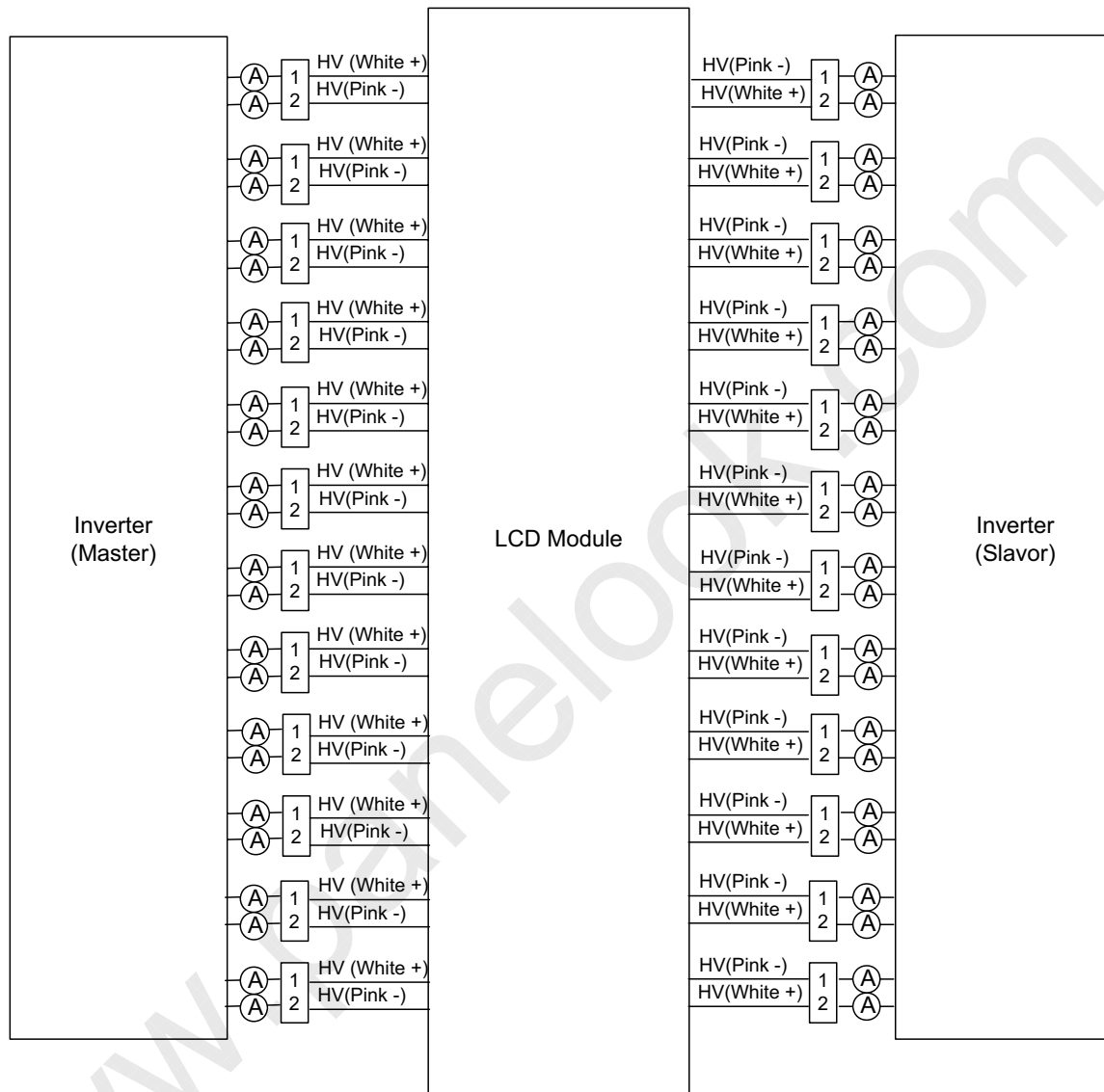

3.2.3 INVERTER INTERFACE CHARACTERISTICS

Parameter	Symbol	Test Condition	Value			Unit	Note	
			Min.	Typ.	Max.			
On/Off Control Voltage	ON	VBLON	—	2.0	—	5.0	V	
	OFF		—	0	—	0.8	V	
Internal PWM Control Voltage	MAX	VIPWM	—	2.85	3.0	3.15	V	Max. Duty Ratio
	MIN		—	—	0	—	V	Min. Duty Ratio
External PWM Control Voltage	HI	VEPWM	—	2.0	—	5.0	V	Duty on
	LO		—	0	—	0.8	V	Duty off
Status Signal	HI	Status	—	3.0	3.3	3.6	V	Normal
	LO		—	0	—	0.8	V	Abnormal
VBL Rising Time	Tr1	—	30	—	50	ms	See as below	
VBL Falling Time	Tf1	—	30	—	50	ms		
Control Signal Rising Time	Tr	—	—	—	100	ms		
Control Signal Falling Time	Tf	—	—	—	100	ms		
PWM Signal Rising Time	TPWMR	—	—	—	50	us		
PWM Signal Falling Time	TPWMF	—	—	—	50	us		
Input Impedance	Rin	—	1	—	—	MΩ		
PWM Delay Time	TPWM	—	100	—	300	ms		
BLON Delay Time	Ton	—	300	—	500	ms		
BLON Off Time	Toff	—	300	—	500	ms		

Note (1) The dimming signal should be valid before backlight turns on by BLON signal. It is inhibited to change the internal/external PWM signal during backlight turn on period.

Note (2) The power sequence and control signal timing are shown in the following figure.

Note (3) The power sequence and control signal timing must follow the figure below. For a certain reason, the inverter has a possibility to be damaged with wrong power sequence and control signal timing.

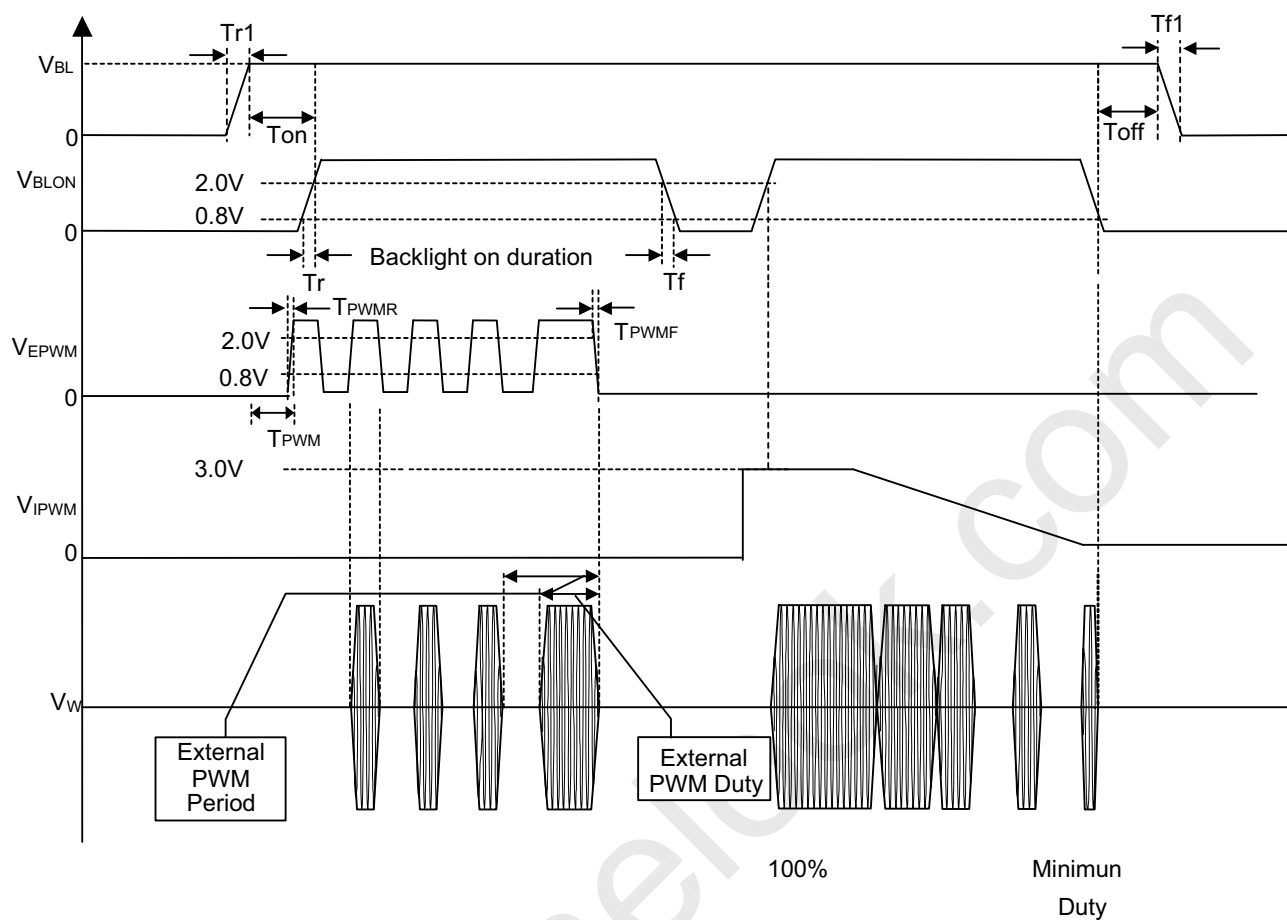

4. BLOCK DIAGRAM OF INTERFACE

4.1 TFT LCD MODULE

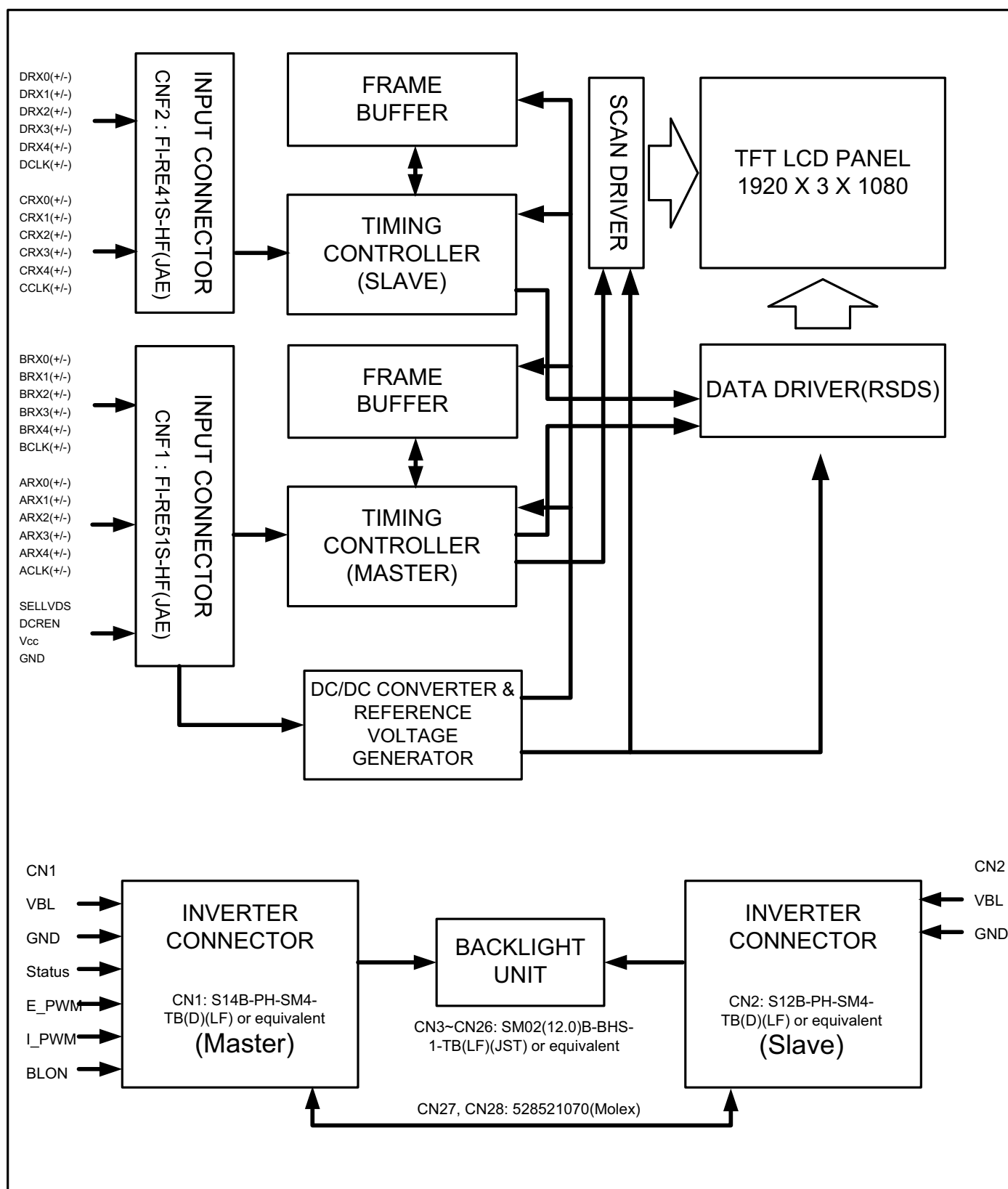

5. INPUT TERMINAL PIN ASSIGNMENT

5.1 TFT LCD Module Input

CNF1 Connector Pin Assignment (FI-RE51S-HF(JAE) or equivalent)

Pin	Name	Description	Note
1	GND	Ground	
2	N.C.	No Connection	(1)
3	N.C.	No Connection	(1)
4	N.C.	No Connection	(1)
5	N.C.	No Connection	(1)
6	N.C.	No Connection	(1)
7	SELLVDS	LVDS Data Format Selection	(2)
8	N.C.	No Connection	(1)
9	N.C.	No Connection	(1)
10	N.C.	No Connection	(1)
11	GND	Ground	
12	ARX0-	First pixel Negative LVDS differential data input. Channel 0	
13	ARX0+	First pixel Positive LVDS differential data input. Channel 0	
14	ARX1-	First pixel Negative LVDS differential data input. Channel 1	
15	ARX1+	First pixel Positive LVDS differential data input. Channel 1	
16	ARX2-	First pixel Negative LVDS differential data input. Channel 2	
17	ARX2+	First pixel Positive LVDS differential data input. Channel 2	
18	GND	Ground	
19	ACLK-	First pixel Negative LVDS differential clock input.	
20	ACLK+	First pixel Positive LVDS differential clock input.	
21	GND	Ground	
22	ARX3-	First pixel Negative LVDS differential data input. Channel 3	
23	ARX3+	First pixel Positive LVDS differential data input. Channel 3	
24	ARX4-	First pixel Negative LVDS differential data input. Channel 4	
25	ARX4+	First pixel Positive LVDS differential data input. Channel 4	
26	N.C.	No Connection	(1)
27	N.C.	No Connection	(1)
28	BRX0-	Second pixel Negative LVDS differential data input. Channel 0	

29	BRX0+	Second pixel Positive LVDS differential data input. Channel 0	
30	BRX1-	Second pixel Negative LVDS differential data input. Channel 1	
31	BRX1+	Second pixel Positive LVDS differential data input. Channel 1	
32	BRX2-	Second pixel Negative LVDS differential data input. Channel 2	
33	BRX2+	Second pixel Positive LVDS differential data input. Channel 2	
34	GND	Ground	
35	BCLK-	Second pixel Negative LVDS differential clock input.	
36	BCLK+	Second pixel Positive LVDS differential clock input.	
37	GND	Ground	
38	BRX3-	Second pixel Negative LVDS differential data input. Channel 3	
39	BRX3+	Second pixel Positive LVDS differential data input. Channel 3	
40	BRX4-	Second pixel Negative LVDS differential data input. Channel 4	
41	BRX4+	Second pixel Positive LVDS differential data input. Channel 4	
42	N.C.	No Connection	(1)
43	N.C.	No Connection	(1)
44	GND	Ground	
45	GND	Ground	
46	GND	Ground	
47	N.C.	No Connection	(1)
48	VCC	+12V power supply	
49	VCC	+12V power supply	
50	VCC	+12V power supply	
51	VCC	+12V power supply	

CNF2 Connector Pin Assignment (FI-RE41S(JAE) or equivalent)

Pin	Name	Description	Note
1	GND	Ground	
2	N.C.	No Connection	(1)
3	N.C.	No Connection	(1)
4	N.C.	No Connection	(1)
5	N.C.	No Connection	(1)
6	N.C.	No Connection	(1)

7	N.C.	No Connection	(1)
8	N.C.	No Connection	(1)
9	GND	Ground	
10	CRX0-	Third pixel Negative LVDS differential data input. Channel 0	
11	CRX0+	Third pixel Positive LVDS differential data input. Channel 0	
12	CRX1-	Third pixel Negative LVDS differential data input. Channel 1	
13	CRX1+	Third pixel Positive LVDS differential data input. Channel 1	
14	CRX2-	Third pixel Negative LVDS differential data input. Channel 2	
15	CRX2+	Third pixel Positive LVDS differential data input. Channel 2	
16	GND	Ground	
17	CCLK-	Third pixel Negative LVDS differential clock input.	
18	CCLK+	Third pixel Positive LVDS differential clock input.	
19	GND	Ground	
20	CRX3-	Third pixel Negative LVDS differential data input. Channel 3	
21	CRX3+	Third pixel Positive LVDS differential data input. Channel 3	
22	CRX4-	Third pixel Negative LVDS differential data input. Channel 4	
23	CRX4+	Third pixel Positive LVDS differential data input. Channel 4	
24	N.C.	No Connection	(1)
25	N.C.	No Connection	(1)
26	DRX0-	Fourth pixel Negative LVDS differential data input. Channel 0	
27	DRX0+	Fourth pixel Positive LVDS differential data input. Channel 0	
28	DRX1-	Fourth pixel Negative LVDS differential data input. Channel 1	
29	DRX1+	Fourth pixel Positive LVDS differential data input. Channel 1	
30	DRX2-	Fourth pixel Negative LVDS differential data input. Channel 2	
31	DRX2+	Fourth pixel Positive LVDS differential data input. Channel 2	
32	GND	Ground	
33	DCLK-	Fourth pixel Negative LVDS differential clock input.	
34	DCLK+	Fourth pixel Positive LVDS differential clock input.	
35	GND	Ground	
36	DRX3-	Fourth pixel Negative LVDS differential data input. Channel 3	
37	DRX3+	Fourth pixel Positive LVDS differential data input. Channel 3	

38	DRX4-	Fourth pixel Negative LVDS differential data input. Channel 4	
39	DRX4+	Fourth pixel Positive LVDS differential data input. Channel 4	
40	N.C.	No Connection	(1)
41	N.C.	No Connection	(1)

Note (1) Please be reserved to open.

Note (2) Low or Open: VESA Format (Default), High: JEIDA Format.

Note (3) LVDS 4-port Data Mapping

Port	Channel of LVDS	Data Stream
1st Port	First Pixel	1, 5, 9,1913, 1917
2nd Port	Second Pixel	2, 6, 10,1914, 1918
3rd Port	Third Pixel	3, 7, 11,1915, 1919
4th Port	Fourth Pixel	4, 8, 12,1916, 1920

5.2 BACKLIGHT UNIT

The pin configuration for the housing and the leader wire is shown in the table below.

CN3~CN26: BHR-04VS-1 (JST).

Pin	Name	Description	Wire Color
1	HV	High Voltage	Pink
2	HV	High Voltage	White

Note (1) The backlight interface housing for high voltage side is a model BHR-04VS-1, manufactured by JST. The mating header on inverter part number is SM02(12.0)B-BHS-1-TB(LF).

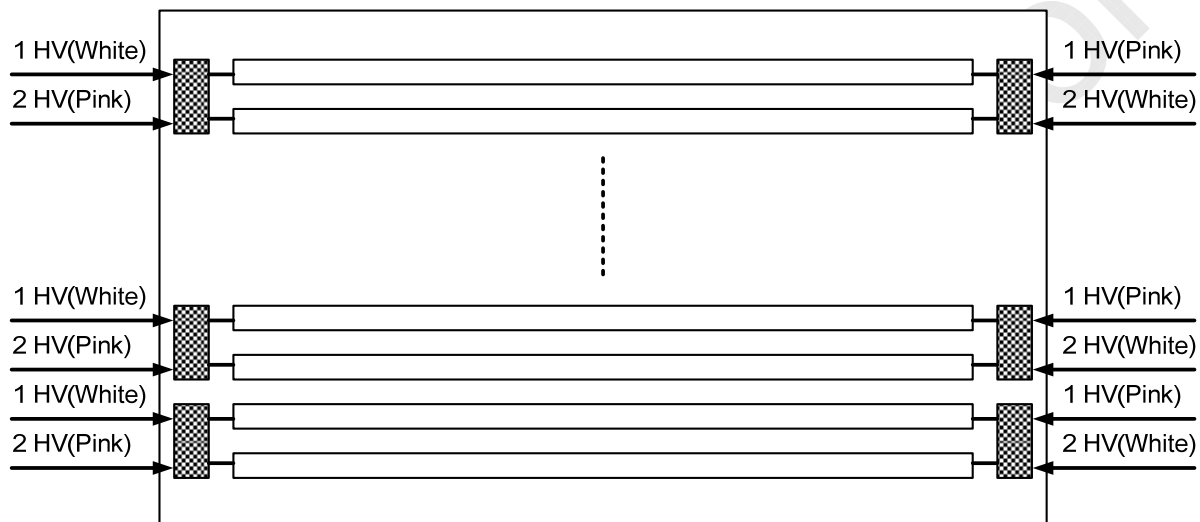

5.3 INVERTER UNIT

CN1: S14B-PH-SM4-TB(D)(LF)(JST) or equivalent

Pin No	Symbol	Feature
1	VBL	+24V
2		
3		
4		
5		
6	GND	GND
7		
8		
9		
10		
11	STATUS	Normal (3.3V) Abnormal(GND)
12	E_PWM	External PWM Control Signal
13	I_PWM	Internal PWM Control Signal
14	BLON	BL ON/OFF

Note (1) Pin 12: External PWM control (use pin 12): Pin 13 must open.

Note (2) Pin 13: Internal PWM control (use pin 13): 0~3.0V and pin 12 must open.

Note (3) Pin 12 and Pin 13 can't open in the same period.

CN2: S12B-PH-SM4-TB(D)(LF)(JST) or equivalent

Pin №	Symbol	Feature
1	VBL	+24V
2		
3		
4		
5		
6	GND	GND
7		
8		
9		
10		
11	NC	NC
12	NC	NC

CN3~CN26: SM02(12.0)B-BHS-1-TB(LF)(JST) or equivalent

Pin №	Symbol	Description
1	CCFL HOT	CCFL high voltage
2	CCFL HOT	CCFL high voltage

CN27, CN28: 528521070 (Molex)

Pin №	Symbol	Description
1	Control Signal	Board to Board
2		Board to Board
3		Board to Board
4		Board to Board
5		Board to Board
6		Board to Board
7		Board to Board
8		Board to Board
9		Board to Board
10		Board to Board

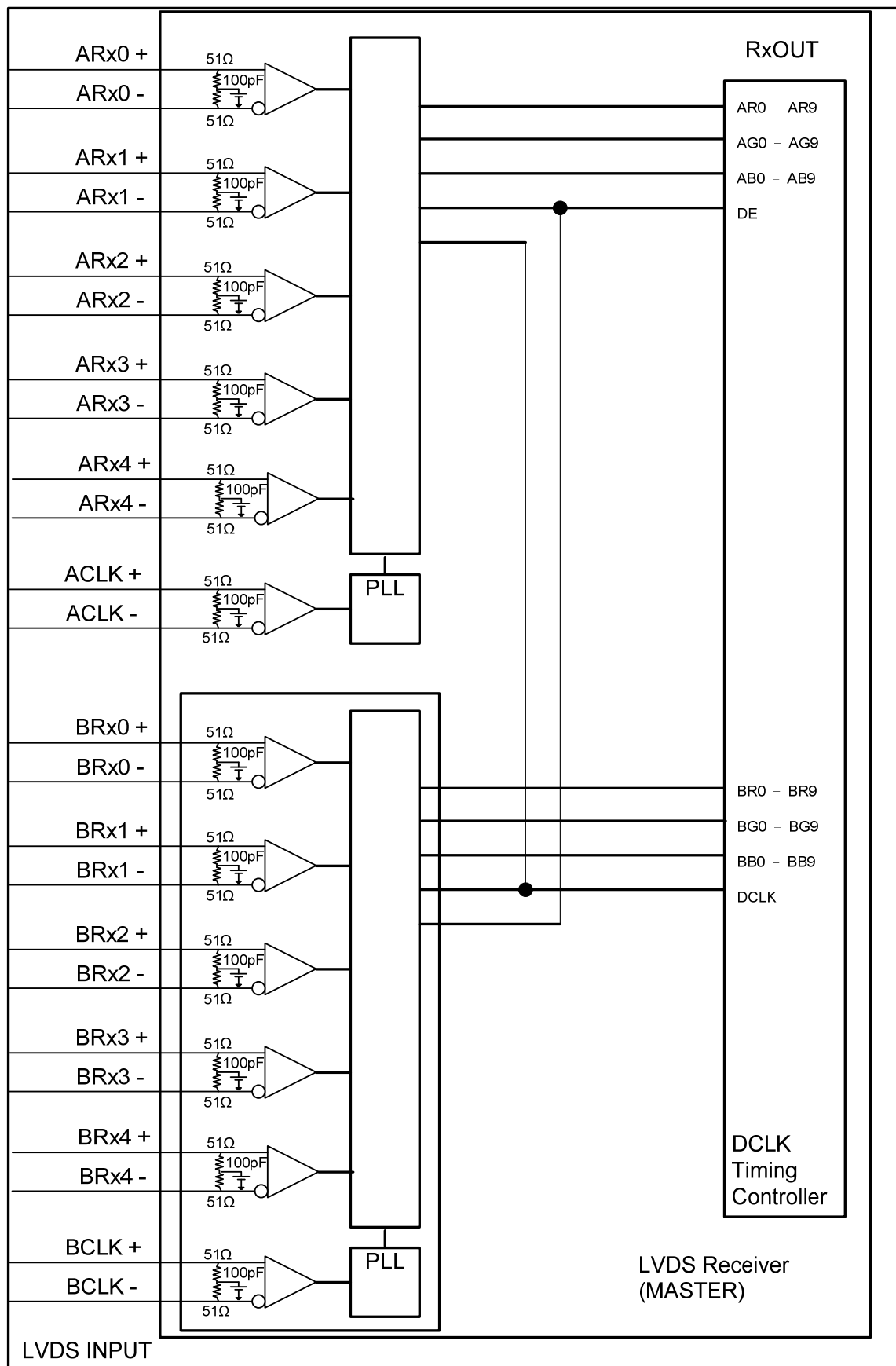
5.4 BLOCK DIAGRAM OF INTERFACE

AR0~AR9: First pixel R data

AG0~AG9: First pixel G data

AB0~AB9: First pixel B data

BR0~BR9: Second pixel R data

BG0~BG9: Second pixel G data

BB0~BB9: Second pixel B data

DE: Data enable signal

DCLK: Data clock signal

The third and fourth pixel are followed the same rules.

CR0~CR9: Third pixel R data

CG0~CG9: Third pixel G data

CB0~CB9: Third pixel B data

DR0~DR9: Fourth pixel R data

DG0~DG9: Fourth pixel G data

DB0~DB9: Fourth pixel B data

Note (1) A ~ D channel are first, second, third and fourth pixel respectively.

Note (2) The system must have the transmitter to drive the module.

Note (3) LVDS cable impedance shall be 50 ohms per signal line or about 100 ohms per twist-pair line when it is used differentially.

5.5 LVDS INTERFACE

VESA Format : SELLVDS = L or Open

JEIDA Format : SELLVDS = H

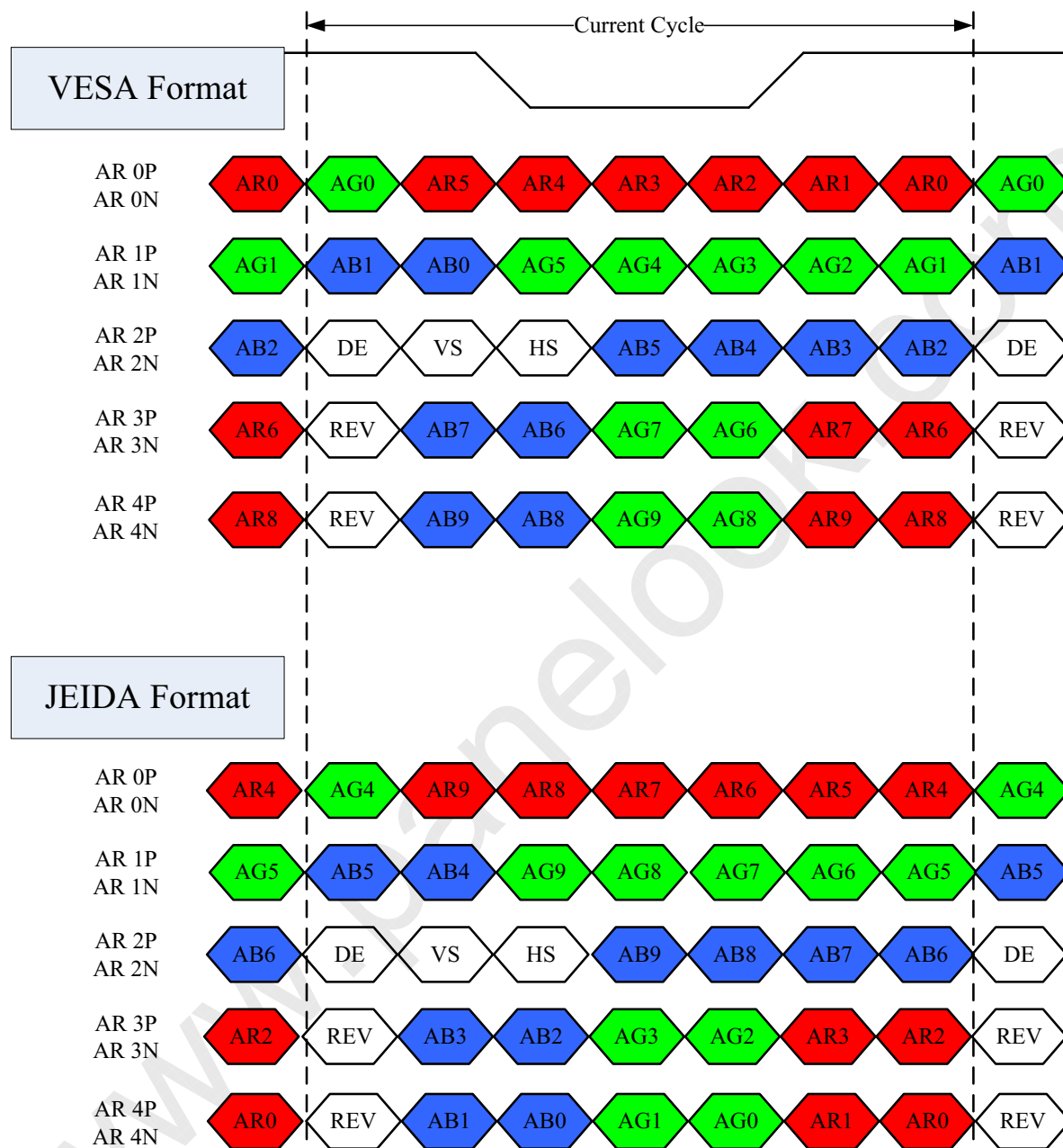

AR0~AR9: First Pixel R Data (9; MSB, 0; LSB)

AG0~AG9: First Pixel G Data (9; MSB, 0; LSB)

AB0~AB9: First Pixel B Data (9; MSB, 0; LSB)

DE : Data enable signal

DCLK : Data clock signal

RSVD : Reserved



Preliminary

5.5 COLOR DATA INPUT ASSIGNMENT

The brightness of each primary color (red, green and blue) is based on the 10-bit gray scale data input for the color. The higher the binary input, the brighter the color. The table below provides the assignment of the color versus data input.

Color		Data Signal																																						
		Red										Green										Blue																		
		R9	R8	R7	R6	R5	R4	R3	R2	R1	R0	G9	G8	G7	G6	G5	G4	G3	G2	G1	G0	B9	B8	B7	B6	B5	B4	B3	B2	B1	B0									
Basic Colors	Black	0	0	0	0	0	0	0	0	0	0	0	0	0	0	0	0	0	0	0	0	0	0	0	0	0	0	0	0	0	0	0	0	0	0	0	0	0	0	0
	Red	1	1	1	1	1	1	1	1	1	1	0	0	0	0	0	0	0	0	0	0	0	0	0	0	0	0	0	0	0	0	0	0	0	0	0	0	0	0	0
	Green	0	0	0	0	0	0	0	0	0	0	1	1	1	1	1	1	1	1	1	0	0	0	0	0	0	0	0	0	0	0	0	0	0	0	0	0	0	0	0
	Blue	0	0	0	0	0	0	0	0	0	0	0	0	0	0	0	0	0	0	0	0	0	0	0	0	0	0	0	0	0	1	1	1	1	1	1	1	1	1	1
	Cyan	0	0	0	0	0	0	0	0	0	0	1	1	1	1	1	1	1	1	1	1	1	1	1	1	1	1	1	1	1	0	0	0	0	0	0	0	0	0	0
	Magenta	1	1	1	1	1	1	1	1	1	1	0	0	0	0	0	0	0	0	0	0	0	0	0	0	0	0	0	0	0	1	1	1	1	1	1	1	1	1	1
	Yellow	1	1	1	1	1	1	1	1	1	1	1	1	1	1	1	1	1	1	1	1	1	1	1	1	1	1	1	1	1	0	0	0	0	0	0	0	0	0	0
	White	1	1	1	1	1	1	1	1	1	1	1	1	1	1	1	1	1	1	1	1	1	1	1	1	1	1	1	1	1	1	1	1	1	1	1	1	1	1	1
Gray Scale Of Red	Red (0) / Dark	0	0	0	0	0	0	0	0	0	0	0	0	0	0	0	0	0	0	0	0	0	0	0	0	0	0	0	0	0	0	0	0	0	0	0	0	0	0	
	Red (1)	0	0	0	0	0	0	0	0	0	1	0	0	0	0	0	0	0	0	0	0	0	0	0	0	0	0	0	0	0	0	0	0	0	0	0	0	0	0	
	Red (2)	0	0	0	0	0	0	0	0	1	0	0	0	0	0	0	0	0	0	0	0	0	0	0	0	0	0	0	0	0	0	0	0	0	0	0	0	0	0	
	...	:	:	:	:	:	:	:	:	:	:	:	:	:	:	:	:	:	:	:	:	:	:	:	:	:	:	:	:	:	:	:	:	:	:	:	:	:	:	
	Red (1021)	1	1	1	1	1	1	1	1	0	1	0	0	0	0	0	0	0	0	0	0	0	0	0	0	0	0	0	0	0	0	0	0	0	0	0	0	0	0	
	Red (1022)	1	1	1	1	1	1	1	1	1	0	0	0	0	0	0	0	0	0	0	0	0	0	0	0	0	0	0	0	0	0	0	0	0	0	0	0	0	0	
	Red (1023)	1	1	1	1	1	1	1	1	1	1	0	0	0	0	0	0	0	0	0	0	0	0	0	0	0	0	0	0	0	0	0	0	0	0	0	0	0	0	
Gray Scale Of Green	Green (0) / Dark	0	0	0	0	0	0	0	0	0	0	0	0	0	0	0	0	0	0	0	0	0	0	0	0	0	0	0	0	0	0	0	0	0	0	0	0	0	0	
	Green (1)	0	0	0	0	0	0	0	0	0	1	0	0	0	0	0	0	0	0	0	0	0	0	0	0	0	0	0	0	0	0	0	0	0	0	0	0	0	0	
	Green (2)	0	0	0	0	0	0	0	0	0	0	0	0	0	0	0	0	0	1	0	0	0	0	0	0	0	0	0	0	0	0	0	0	0	0	0	0	0	0	
	...	:	:	:	:	:	:	:	:	:	:	:	:	:	:	:	:	:	:	:	:	:	:	:	:	:	:	:	:	:	:	:	:	:	:	:	:	:	:	
	Green (1021)	0	0	0	0	0	0	0	0	0	0	1	1	1	1	1	1	1	0	1	0	0	0	0	0	0	0	0	0	0	0	0	0	0	0	0	0	0	0	
	Green (1022)	0	0	0	0	0	0	0	0	0	0	1	1	1	1	1	1	1	0	0	0	0	0	0	0	0	0	0	0	0	0	0	0	0	0	0	0	0	0	
	Green (1023)	0	0	0	0	0	0	0	0	0	0	1	1	1	1	1	1	1	1	0	0	0	0	0	0	0	0	0	0	0	0	0	0	0	0	0	0	0	0	
Gray Scale Of Blue	Blue (0) / Dark	0	0	0	0	0	0	0	0	0	0	0	0	0	0	0	0	0	0	0	0	0	0	0	0	0	0	0	0	0	0	0	0	0	0	0	0	0	0	
	Blue (1)	0	0	0	0	0	0	0	0	0	0	0	0	0	0	0	0	0	0	0	0	0	0	0	0	0	0	0	0	0	0	0	0	0	0	0	0	0	1	
	Blue (2)	0	0	0	0	0	0	0	0	0	0	0	0	0	0	0	0	0	0	0	0	0	0	0	0	0	0	0	0	0	0	0	0	0	0	0	0	1	0	
	...	:	:	:	:	:	:	:	:	:	:	:	:	:	:	:	:	:	:	:	:	:	:	:	:	:	:	:	:	:	:	:	:	:	:	:	:	:	:	
	Blue (1021)	0	0	0	0	0	0	0	0	0	0	0	0	0	0	0	0	0	0	1	1	1	1	1	1	1	1	1	1	1	1	1	1	1	1	1	0	1	1	
	Blue (1022)	0	0	0	0	0	0	0	0	0	0	0	0	0	0	0	0	0	0	0	1	1	1	1	1	1	1	1	1	1	1	1	1	1	1	1	1	1	0	
	Blue (1023)	0	0	0	0	0	0	0	0	0	0	0	0	0	0	0	0	0	0	0	1	1	1	1	1	1	1	1	1	1	1	1	1	1	1	1	1	1	1	

Note (1) 0: Low Level Voltage, 1: High Level Voltage

6. INTERFACE TIMING

6.1 INPUT SIGNAL TIMING SPECIFICATIONS

($T_a = 25 \pm 2 \text{ }^\circ\text{C}$)

The input signal timing specifications are shown as the following table and timing diagram.

Signal	Item	Symbol	Min.	Typ.	Max.	Unit	Note
LVDS Receiver Clock	Frequency	1/Tc	60	74.25	80	MHz	-
	Input cycle to cycle jitter	Trcl	-	-	200	ps	-
LVDS Receiver Data	Setup Time	Tlvsu	600	-	-	ps	-
	Hold Time	Tlvhd	600	-	-	ps	-
Vertical Active Display Term	Frame Rate		-	120	-	Hz	
	Total	Tv	1115	1125	1139	Th	Tv=Tvd+Tvb
	Display	Tvd	1080	1080	1080	Th	-
	Blank	Tvb	35	45	59	Th	-
Horizontal Active Display Term	Total	Th	540	550	575	Tc	Th=Thd+Thb
	Display	Thd	480	480	480	Tc	-
	Blank	Thb	45	70	95	Tc	-

Note : Since the module is operated in DE only mode, Hsync and Vsync input signals should be set to low logic level. Otherwise, this module would operate abnormally.

INPUT SIGNAL TIMING DIAGRAM

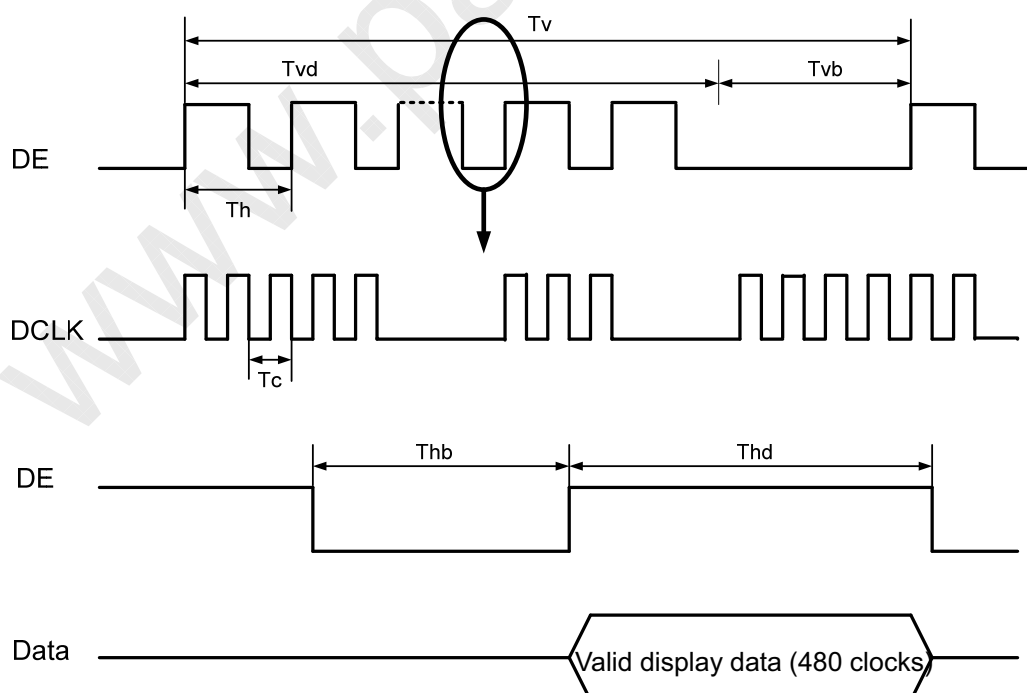

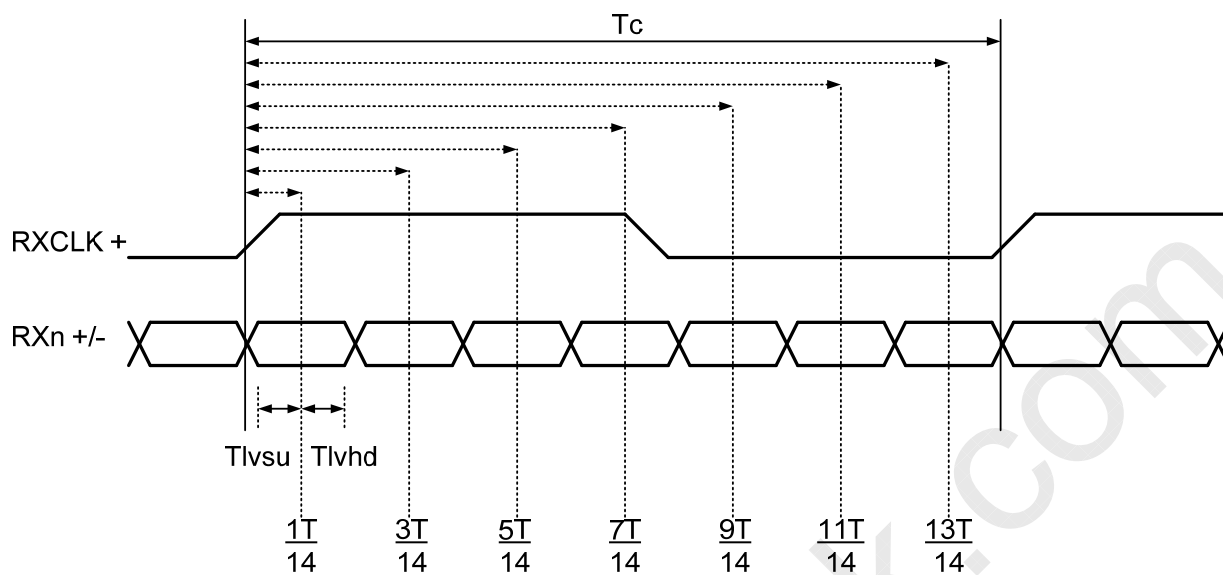
LVDS INPUT INTERFACE TIMING DIAGRAM

6.2 POWER ON/OFF SEQUENCE

($T_a = 25 \pm 2 \text{ }^\circ\text{C}$)

To prevent a latch-up or DC operation of LCD module, the power on/off sequence should follow the diagram below.

POWER ON/OFF SEQUENCE

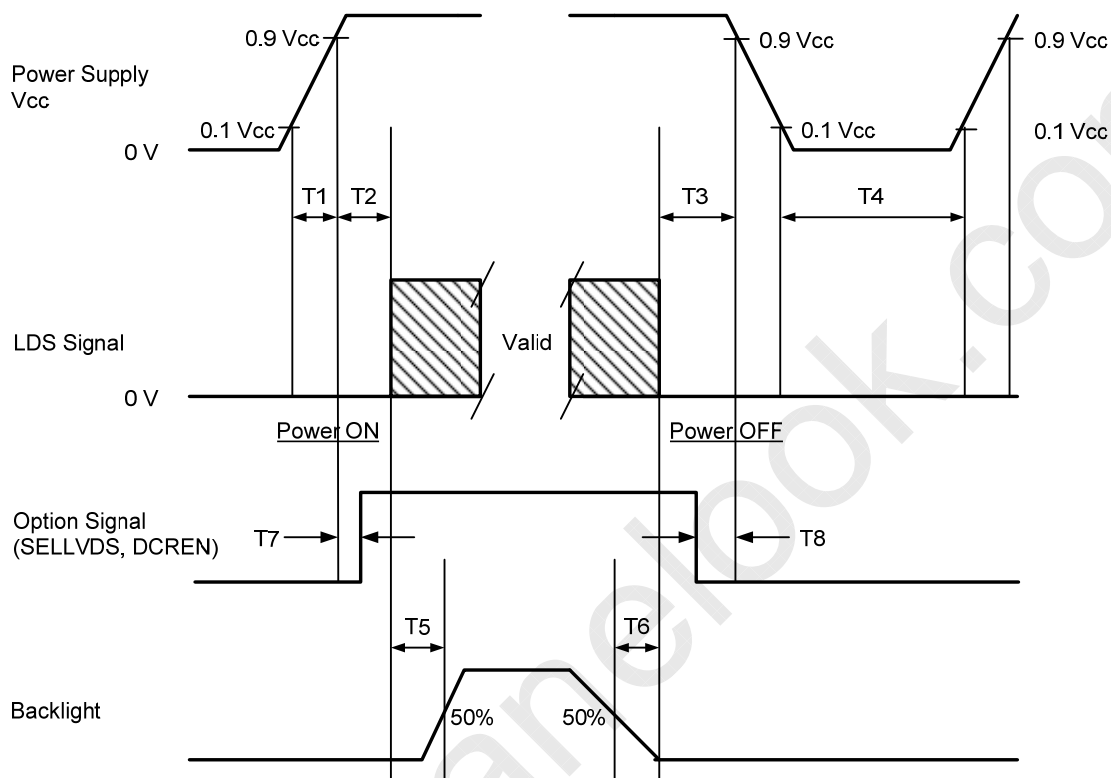

Signal	Min.	Typ.	Max.	Unit	Note
T1	0.5	-	10	ms	-
T2	0	-	50	ms	-
T3	0	-	50	ms	-
T4	500	-	-	ms	-
T5	500	-	-	ms	-
T6	100	-	-	ms	-
T7	0	-	T2	-	-
T8	0	-	-	-	-

Note.

- (a) The supply voltage of the external system for the module input should follow the definition of Vcc.
- (b) Apply the lamp voltage within the LCD operation range. When the backlight turns on before the LCD operation or the LCD turns off before the backlight turns off, the display may momentarily become abnormal screen.
- (c) In case of VCC is in off level, please keep the level of input signals on the low or high impedance.
- (d) T4 should be measured after the module has been fully discharged between power off and on period.
- (e) Interface signal shall not be kept at high impedance when the power is on.

7. OPTICAL CHARACTERISTICS

7.1 TEST CONDITIONS

Item	Symbol	Value	Unit
Ambient Temperature	Ta	25±2	°C
Ambient Humidity	Ha	50±10	%RH
Supply Voltage	VCC	12	V
Input Signal	According to typical value in "3. ELECTRICAL CHARACTERISTICS"		
Lamp Current	IL	5.0±0.5	mA
Oscillating Frequency (Inverter)	FW	43±3	KHz
Vertical Frame Rate	Fr	120	Hz

The LCD module should be stabilized at given temperature for 1 hour to avoid abrupt temperature change during measuring. In order to stabilize the luminance, the measurement should be executed after lighting backlight for 1 hour in a windless room.

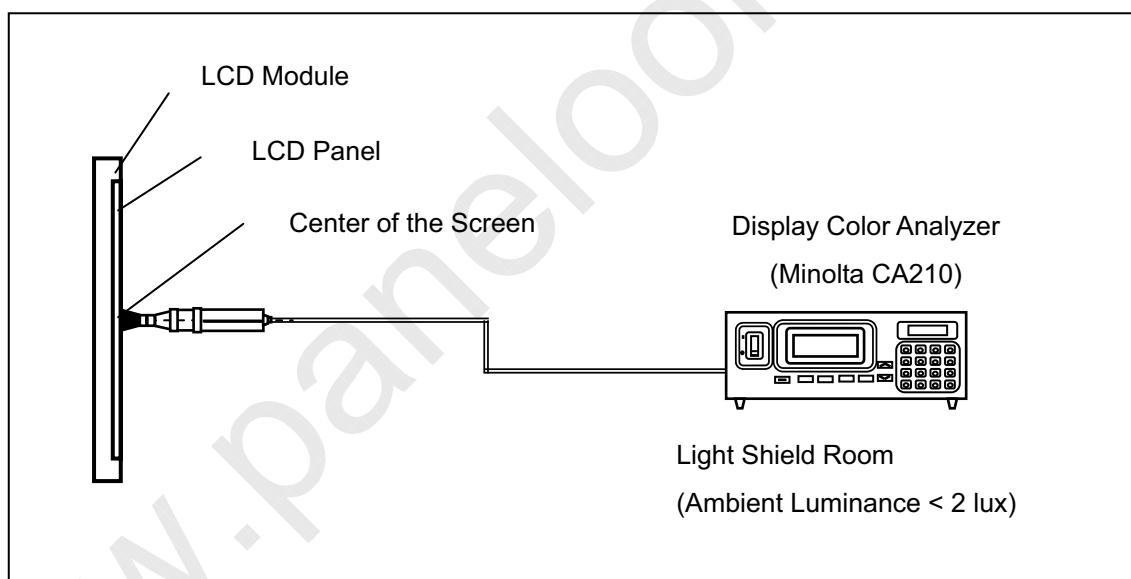

7.2 OPTICAL SPECIFICATIONS

The relative measurement methods of optical characteristics are shown in 7.2. The following items should be measured under the test conditions described in 7.1 and stable environment shown in Note (6).

Item	Symbol	Condition	Min.	Typ.	Max.	Unit	Note	
Contrast Ratio	CR	$\theta_x=0^\circ, \theta_y=0^\circ$ Viewing angle at normal direction	(3000)	(4000)	-	-	Note (2)	
Response Time	Gray to gray		-	(4.0)	(8.0)	ms	Note (3)	
Center Luminance of White	LC		(400)	(500)	-	cd/m^2	Note (4)	
White Variation	δW		-	-	(1.3)	-	Note (7)	
Cross Talk	CT		-	-	(4)	%	Note (5)	
Color Chromaticity	Red		Rx	Typ. -0.03	(0.658)	Typ. +0.03	-	-
			Ry		(0.328)		-	
	Green		Gx		(0.190)		-	
			Gy		(0.675)		-	
	Blue		Bx		(0.151)		-	
		By	(0.061)		-			
	White	Wx	(0.280)		-			
Wy	(0.285)	-						
	Color Gamut	C.G	-	(92)	-	%	NTSC	
Viewing Angle	Horizontal	θ_{x+}	80	88	-	Deg.	Note (1)	
		θ_{x-}	80	88	-			
	Vertical	θ_{y+}	80	88	-			
		θ_{y-}	80	88	-			
Gamma			-	(2.2)	-	-	-	

Note (1) Definition of Viewing Angle (θ_x, θ_y):

Viewing angles are measured by Eldim EZ-Contrast 160R

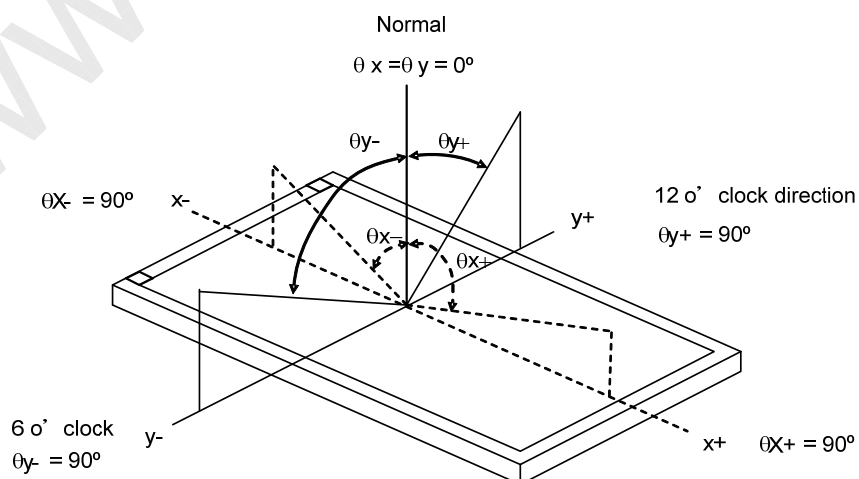

Note (2) Definition of Contrast Ratio (CR):

The contrast ratio can be calculated by the following expression.

$$\text{Contrast Ratio (CR)} = \frac{\text{Surface Luminance with all white pixels}}{\text{Surface Luminance with all black pixels}}$$

CR = CR (5), where CR (X) is corresponding to the Contrast Ratio of the point X at the figure in Note (7).

Note (3) Definition of Gray-to-Gray Switching Time:

Optical Response

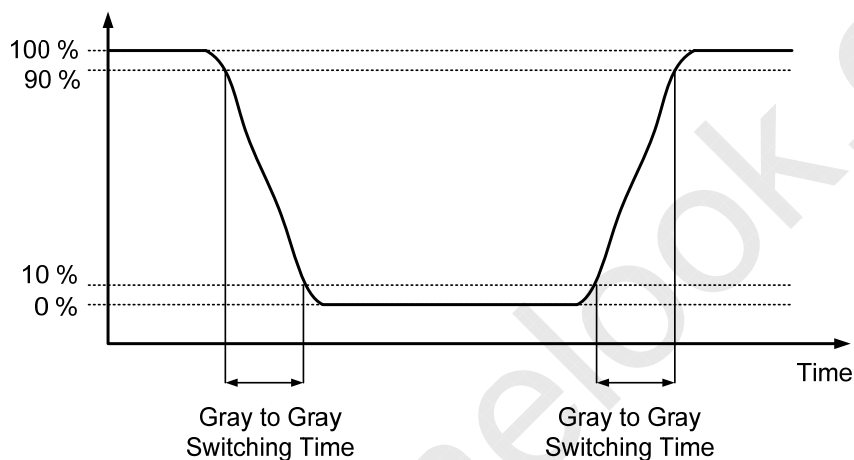

The driving signal means the signal of gray level 0, 124, 252, 380, 508, 636, 764, 892 and 1023.

Gray to gray average time means the average switching time of gray level 0, 124, 252, 380, 508, 636, 764, 892, 1023 to each other.

Note (4) Definition of Luminance of White (LC, LAVE):

Measure the luminance of gray level 1023 at center point and 5 points

LC = L (5), where L (X) is corresponding to the luminance of the point X at the figure in Note (7).

Note (5) Definition of Cross Talk (CT):

$$\text{CT} = |YB - YA| / YA \times 100 (\%)$$

Where:

YA = Luminance of measured location without gray level 0 pattern (cd/m²)

YB = Luminance of measured location with gray level 0 pattern (cd/m²)

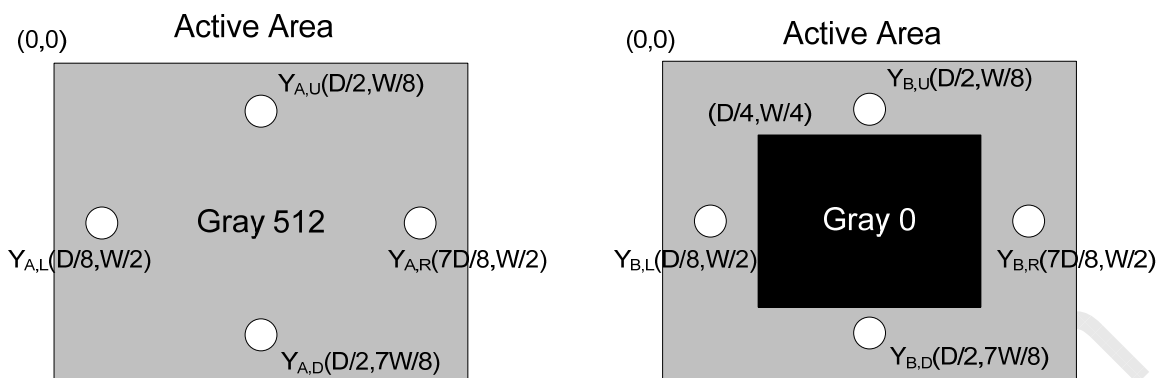

Note (6) Definition of White Variation (δW):

Measure the luminance of gray level 1023 at 5 points

$$\delta W = \text{Maximum} [L (1), L (2), L (3), L (4), L (5)] / \text{Minimum} [L (1), L (2), L (3), L (4), L (5)]$$

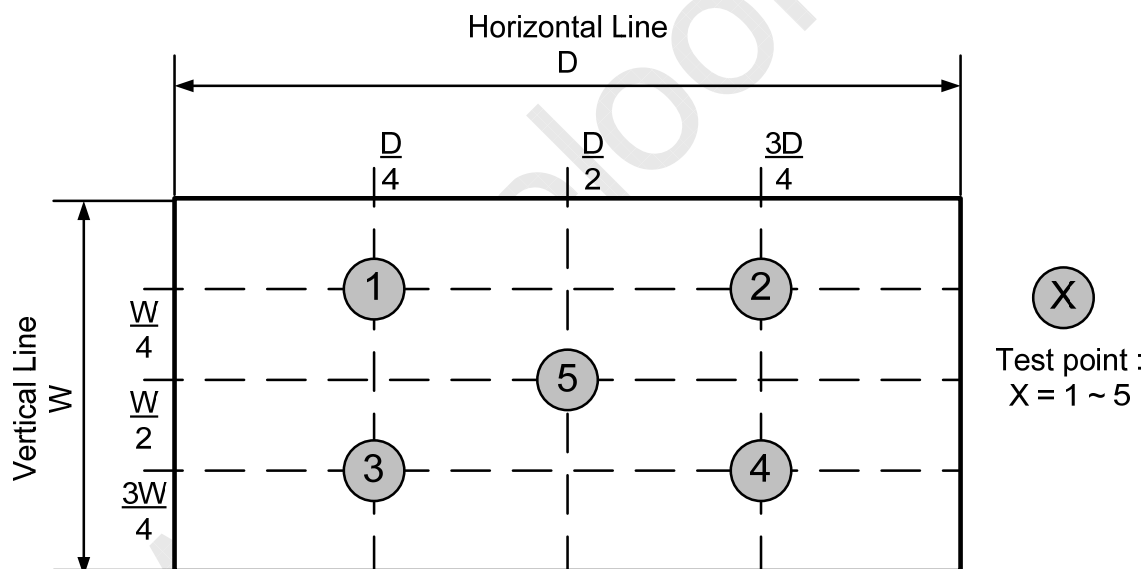

8. PRECAUTIONS

8.1 ASSEMBLY AND HANDLING PRECAUTIONS

- [1] Do not apply rough force such as bending or twisting to the module during assembly.
- [2] It is recommended to assemble or to install a module into the user's system in clean working areas. The dust and oil may cause electrical short or worsen the polarizer.
- [3] Do not apply pressure or impulse to the module to prevent the damage of LCD panel and Backlight.
- [4] Always follow the correct power-on sequence when the LCD module is turned on. This can prevent the damage and latch-up of the CMOS LSI chips.
- [5] Do not plug in or pull out the I/F connector while the module is in operation.
- [6] Do not disassemble the module.
- [7] Use a soft dry cloth without chemicals for cleaning, because the surface of polarizer is very soft and easily scratched.
- [8] Moisture can easily penetrate into LCD module and may cause the damage during operation.
- [9] When storing modules as spares for a long time, the following precaution is necessary.
 - [9.1] Do not leave the module in high temperature, and high humidity for a long time. It is highly recommended to store the module with temperature from 0 to 35°C at normal humidity without condensation.
 - [9.2] The module shall be stored in dark place. Do not store the TFT-LCD module in direct sunlight or fluorescent light.
- [10] When ambient temperature is lower than 10°C, the display quality might be reduced. For example, the response time will become slow, and the starting voltage of CCFL will be higher than that of room temperature.

8.2 SAFETY PRECAUTIONS

- [1] The startup voltage of a Backlight is approximately 1000 Volts. It may cause an electrical shock while assembling with the inverter. Do not disassemble the module or insert anything into the Backlight unit.
- [2] If the liquid crystal material leaks from the panel, it should be kept away from the eyes or mouth. In case of contact with hands, skin or clothes, it has to be washed away thoroughly with soap.
- [3] After the module's end of life, it is not harmful in case of normal operation and storage.

9. DEFINITION OF LABELS

9.1 CMO MODULE LABEL

The barcode nameplate is pasted on each module as illustration, and its definitions are as following explanation.

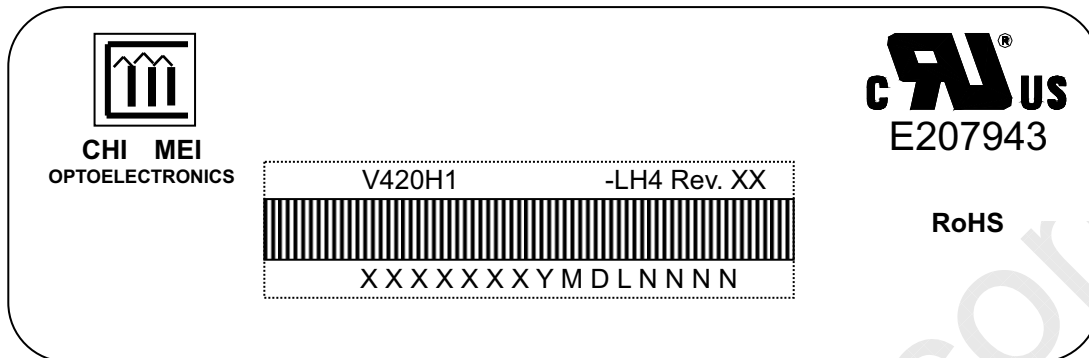

Model Name: V420H1-LH4

Revision: Rev. XX, for example: A0, A1... B1, B2... or C1, C2...etc.

Serial ID: X X X X X X Y M D L N N N N

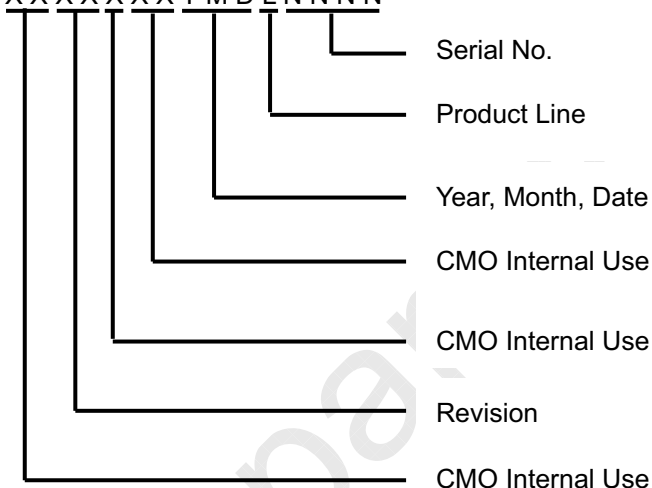

Serial ID includes the information as below:

Manufactured Date:

Year: 0~9, for 2000~2009

Month: 1~9, A~C, for Jan. ~ Dec.

Day: 1~9, A~Y, for 1st to 31st, exclude I, O, and U.

Revision Code: Cover all the change

Serial No.: Manufacturing sequence of product

Product Line: 1 -> Line1, 2 -> Line 2, ...etc.

10. PACKAGING

10.1 PACKAGING SPECIFICATIONS

5 LCD TV modules / 1 Box

Box dimensions: 1040(L) X 310 (W) X 640(H)

Weight: approximately 60 Kg (5 modules per box)

10.2 PACKAGING METHOD

Figures 10-1 and 10-2 are the packing method.

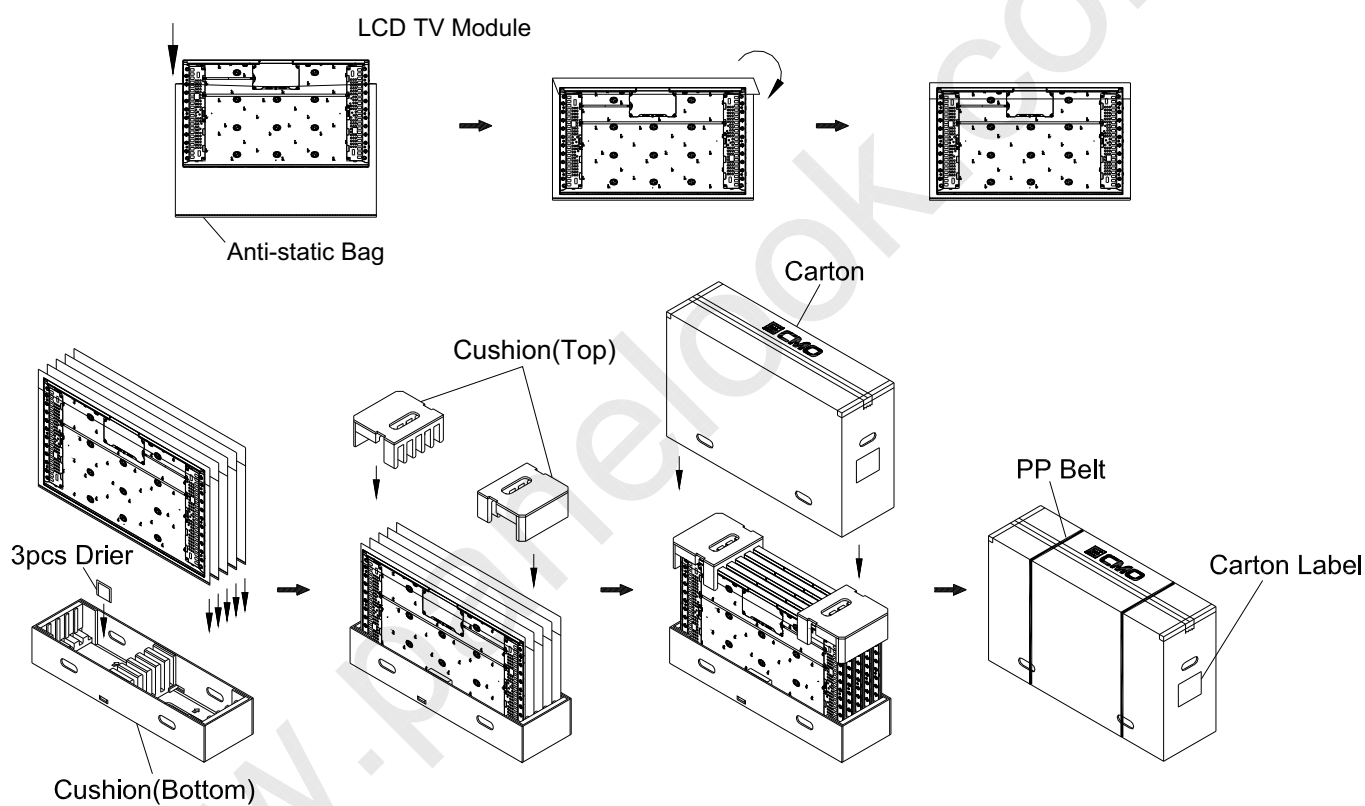
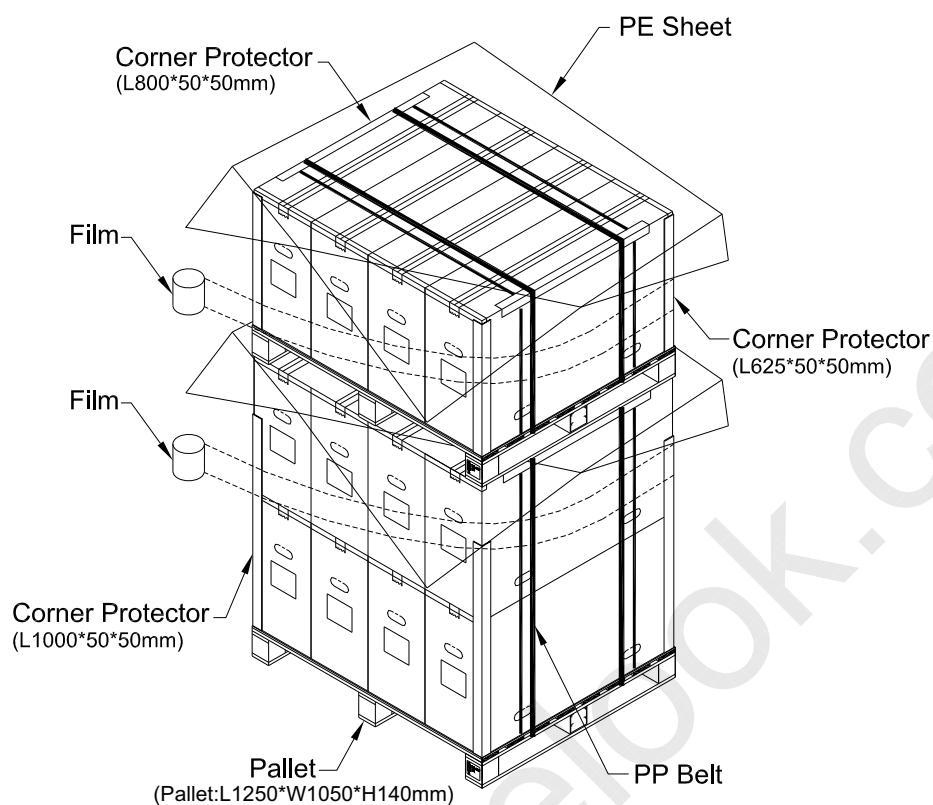

Figure.10-1 Packing method

Sea / Land Transportation (40ft Container)



Air Transportation

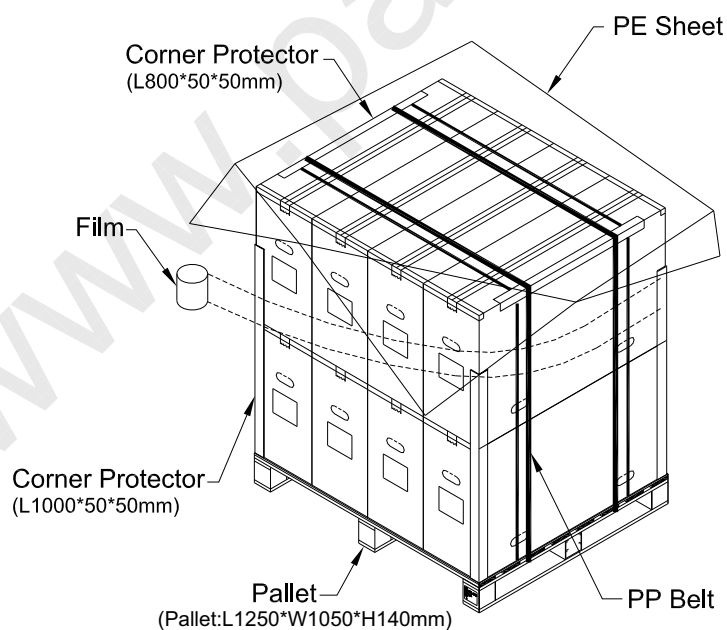
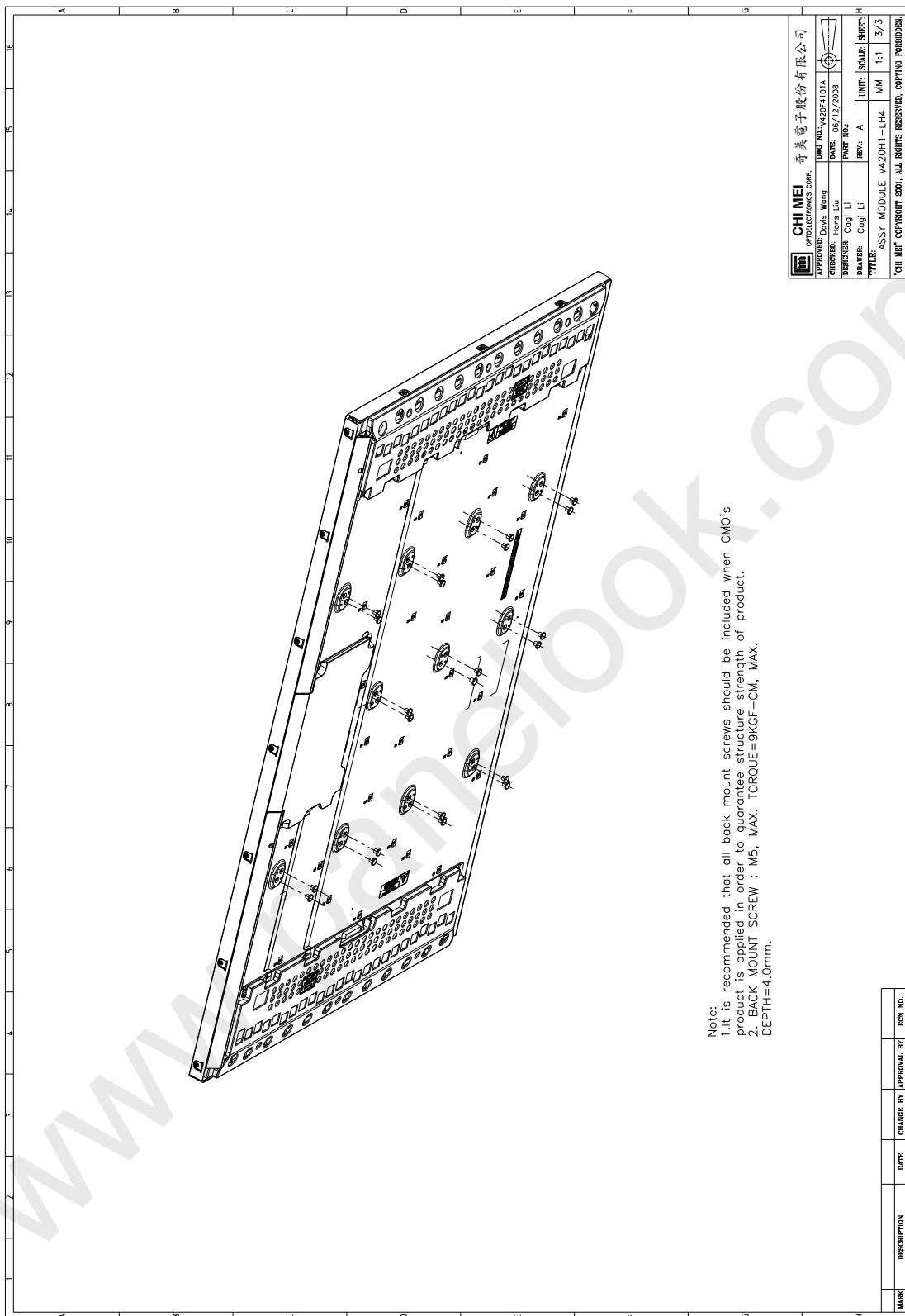

Figure.10-2 Packing method



Note:
1. It is recommended that all back mount screws should be included when CMO's product is applied in order to guarantee structure strength of product.
2. BACK MOUNT SCREW : M5, MAX. TORQUE=9KGF-CM, MAX. DEPTH=4.0mm.

CHI MEI OPTOELECTRONICS CORP. 奇美電子股份有限公司	
APPROVER: Denis Wang	DWG NO.: V420H1-LH4
DESIGNER: Hsueh Li	DATE: 06/12/2008
DRAWER: Csp Lj	PART NO.:
	REV.: A
UNIT: SI/INCH	SHEET: 3/3
TITLE: ASSY MODULE V420H1-LH4	
MM 1:1	
"CHI MEI" COPYRIGHT 2001. ALL RIGHTS RESERVED. COPYING FORBIDDEN.	

MARK	DESCRIPTION	DATE	CHANGE BY	APPROVAL BY	ECN NO.