

TFT LCD Approval Specification

MODEL NO.: V420H1 – LH5

Customer: _____
Approved by: _____
Note:

Approved By	TV Head Division
	Chao-Chun Chung

Reviewed By	QA Dept.	Product Development Div.
	Hsin-Nan Chen	WT Lin

Prepared By	LCD TV Marketing and Product Management Div.	
	CY Chang	Justin Wang

CONTENTS

REVISION HISTORY.....	4
1. GENERAL DESCRIPTION.....	5
1.1 OVERVIEW.....	5
1.2 FEATURES.....	5
1.3 APPLICATION.....	5
1.4 GENERAL SPECIFICATIONS.....	5
1.5 MECHANICAL SPECIFICATIONS.....	6
2. ABSOLUTE MAXIMUM RATINGS.....	7
2.1 ABSOLUTE RATINGS OF ENVIRONMENT.....	7
2.2 PACKAGE STORAGE.....	8
2.3 ELECTRICAL ABSOLUTE RATINGS.....	8
2.3.1 TFT LCD MODULE.....	8
2.3.2 BACKLIGHT INVERTER UNIT.....	8
3. ELECTRICAL CHARACTERISTICS.....	9
3.1 TFT LCD MODULE.....	9
3.2 BACKLIGHT CONNECTOR PIN CONFIGURATION.....	122
3.2.1 LAMP SPECIFICATION.....	12
3.2.2 ELECTRICAL SPECIFICATION.....	122
3.2.3 INVERTER INTERFACE CHARACTERISTICS.....	14
4. BLOCK DIAGRAM OF INTERFACE.....	116
4.1 TFT LCD MODULE.....	16
5. INPUT TERMINAL PIN ASSIGNMENT.....	17
5.1 TFT LCD Module Input.....	17
5.2 BACKLIGHT UNIT.....	18
5.3 INVERTER UNIT.....	20
5.4 BLOCK DIAGRAM OF INTERFACE.....	21
5.5 LVDS INTERFACE.....	24
5.6 COLOR DATA INPUT ASSIGNMENT.....	25
6. INTERFACE TIMING.....	26
6.1 INPUT SIGNAL TIMING SPECIFICATIONS.....	26



6.2 POWER ON/OFF SEQUENCE..... 錯誤! 尚未定義書籤。

7. OPTICAL CHARACTERISTICS 26

 7.1 TEST CONDITIONS..... 29

 7.2 OPTICAL SPECIFICATIONS..... 30

8. PRECAUTIONS..... 33

 8.1 ASSEMBLY AND HANDLING PRECAUTIONS..... 33

 8.2 SAFETY PRECAUTIONS 33

9. DEFINITION OF LABELS..... 34

 9.1 CMO MODULE LABEL 34

10. PACKAGING..... 35

 10.1 PACKAGING SPECIFICATIONS..... 35

 10.2 PACKAGING METHOD 錯誤! 尚未定義書籤。

11. MECHANICAL CHARACTERISTICS 37

REVISION HISTORY

Version	Date	Page(New)	Section	Description
Ver. 0.0	Oct. 15, 2008	All	All	The tentative specification was first issued.
Ver. 1.0	Dec. 19, 2008	5 6 9 11 11-12 13 16-17 18-19 24 26 29 34-35 36-38	1.2 1.5 3.1 3.2.1 3.2.2 3.2.3 5.1 5.3 6.1 6.2 7.2 10 11	Revised fast response time Revised weight Updated TFT LCD module parameter Updated Lamp specification Updated BL electrical specification Updated inverter interface characteristics Updated TFT LCD module input Updated inverter unit Updated input signal timing specifications Updated Power ON/OFF sequence Updated optical specifications Updated packing Updated mechanical characteristics
Ver. 1.0	Dec. 23, 2008	18	5.3	Updated inverter pin 12 define
Ver. 1.0	Dec. 24, 2008	5 29-31	1.1 7.2	Modified "8-bit + FRC" to "10-bit" Updated Center Luminance of White spec
Ver. 1.1	Dec. 31, 2008	13 14 17	3.2.3 3.2.3 5.1	Add note(4) Updated power sequence and control signal timing fig. Updated pin define
Ver. 2.0	Feb. 12, 2009	11 16 17-19 29 30 35 35 37-39	3.2.1 3.2.2 5.1 5.1 7.1 7.2 10.1 10.2 11	Updated BLU connector pin configure. Updated BLU connector pin configure. Updated TFT LCD Module Input Updated LVDS pin assignment. Updated optical measurement condition. Updated optical specification. Updated package specification. Updated package specification. Updated ME specification.
Ver. 2.1	Apr. 8, 2009	13 13 14 15 26 38	3.2.3 3.2.3 3.2.3 4.1 6.1 11	Modified Internal PWM Control Voltage Max. value Deleted Note 4 Modified the V_{IPWM} value Modified the Block Diagram of the BLU Modified Vertical Active Display Term and Horizontal Active Display Term Modified Mechanical Characteristics (Removed FFC)
Ver. 2.2	Apr. 18, 2009	11 13 14	3.2.2 3.2.3 3.2.3	Updated Max Values of Power Consumption Deleted Max Values of VBL Rising/Falling Time, PWM Delay Time, BLON Delay Time, and BLON Off Time Modified the V_{IPWM} value
Ver. 2.3	Apr. 23, 2009	13 25	3.2.3 6.1	Modified BLON Delay Time and BLON Off Time Updated Frame Rate
Ver. 2.4	Jun. 4, 2009	30	7.1	Modified Oscillating Frequency
Ver. 2.5	Aug. 6, 2009	9-11 16 17-19 28 40-47 35-36	3.1 4.1 5.1 6.2 Appendix 10	TFT LCD MODULE TFT LCD MODULE TFT LCD Module Input POWER ON/OFF SEQUENCE

1. GENERAL DESCRIPTION

1.1 OVERVIEW

V420H1-LH5 is a 42" TFT Liquid Crystal Display module with 12-CCFL Backlight unit and 2ch-LVDS interface. This module supports 1920 x 1080 Full HDTV format and can display 1.07G colors (10-bit/color). The inverter module for backlight is built-in.

1.2 FEATURES

- High brightness (500 nits)
- High contrast ratio (4000:1)
- Fast response time (Gray to gray average 4.0 ms)
- High color saturation (NTSC 72%)
- Full HDTV (1920 x 1080 pixels) resolution, true HDTV format
- DE (Data Enable) only mode
- LVDS (Low Voltage Differential Signaling) interface
- Optimized response time for 120 Hz frame rate with MEMC
- Ultra wide viewing angle : Super MVA technology
- RoHS compliance

1.3 APPLICATION

- Standard Living Room TVs.
- Public Display Application.
- Home Theater Application.
- MFM Application.

1.4 GENERAL SPECIFICATIONS

Item	Specification	Unit	Note
Active Area	930.24(H) x 523.26 (V) (42.02" diagonal)	mm	(1)
Bezel Opening Area	937.24 (H) x 530.26 (V)	mm	
Driver Element	a-si TFT active matrix	-	-
Pixel Number	1920 x R.G.B. x 1080	pixel	-
Pixel Pitch(Sub Pixel)	0.1615 (H) x 0.4845 (V)	mm	-
Pixel Arrangement	RGB vertical stripe	-	-
Display Colors	1.07G	color	-
Display Operation Mode	Transmissive mode / Normally black	-	-
Surface Treatment	Anti-Glare coating (Haze 11%) Hard coating (3H)	-	(2)

Note (1) Please refer to the attached drawings in chapter 9 for more information about the front and back outlines.

Note (2) The spec. of the surface treatment is temporarily for this phase. CMO reserves the rights to change this feature.

1.5 MECHANICAL SPECIFICATIONS

Item		Min.	Typ.	Max.	Unit	Note
Module Size	Horizontal (H)	-	983.0	-	mm	(1), (2)
	Vertical (V)	-	576.0	-	mm	
	Depth (D)	-	50.8	-	mm	
Weight		-	10400	-	g	-

Note (1) Please refer to the attached drawings for more information of front and back outline dimensions.

Note (2) Module Depth is between bezel to T-CON cover.

2. ABSOLUTE MAXIMUM RATINGS

2.1 ABSOLUTE RATINGS OF ENVIRONMENT

Item	Symbol	Value		Unit	Note
		Min.	Max.		
Storage Temperature	TST	-20	+60	°C	(1)
Operating Ambient Temperature	TOP	0	50	°C	(1), (2)
Shock (Non-Operating)	SNOP	-	50	G	(3), (5)
Vibration (Non-Operating)	VNOP	-	1.0	G	(4), (5)

Note (1) Temperature and relative humidity range is shown in the figure below.

(a) 90 %RH Max. ($T_a \leq 40\text{ }^\circ\text{C}$).

(b) Wet-bulb temperature should be 39 °C Max. ($T_a > 40\text{ }^\circ\text{C}$).

(c) No condensation.

Note (2) The maximum operating temperature is based on the test condition that the surface temperature of display area is less than or equal to 65 °C with LCD module alone in a temperature controlled chamber. Thermal management should be considered in final product design to prevent the surface temperature of display area from being over 65 °C. The range of operating temperature may degrade in case of improper thermal management in final product design.

Note (3) 11 ms, half sine wave, 1 time for $\pm X$, $\pm Y$, $\pm Z$.

Note (4) 10 ~ 200 Hz, 10 min, 1 time each X, Y, Z.

Note (5) At testing Vibration and Shock, the fixture in holding the module has to be hard and rigid enough so that the module would not be twisted or bent by the fixture.

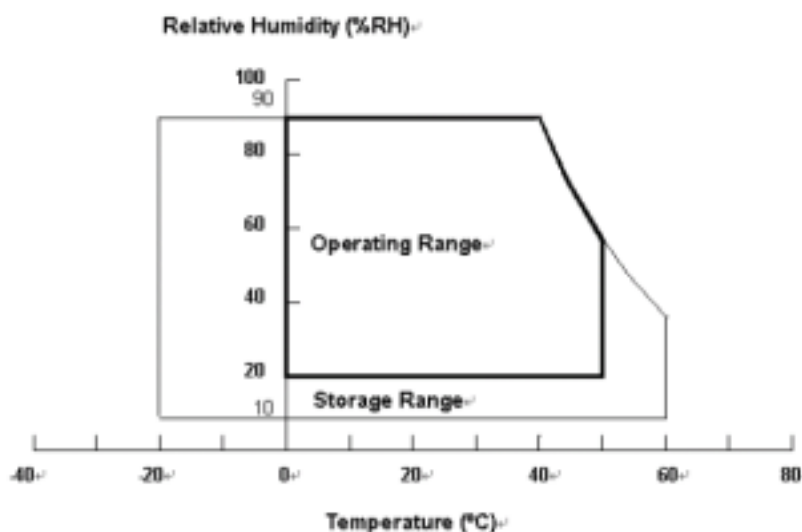

2.2 PACKAGE STORAGE

When storing modules as spares for a long time, the following precaution is necessary.

- (a) Do not leave the module in high temperature, and high humidity for a long time, It is highly recommended to store the module with temperature from 0 to 35 °C at normal humidity without condensation.
- (b) The module shall be stored in dark place. Do not store the TFT-LCD module in direct sunlight or fluorescent light.

2.3 ELECTRICAL ABSOLUTE RATINGS

2.3.1 TFT LCD MODULE

Item	Symbol	Value		Unit	Note
		Min.	Max.		
Power Supply Voltage	VCC	-0.3	13.5	V	(1)
Logic Input Voltage	VIN	-0.3	3.6	V	

2.3.2 BACKLIGHT INVERTER UNIT

Item	Symbol	Value		Unit	Note
		Min.	Max.		
Lamp Voltage	VW	—	3000	VRMS	
Power Supply Voltage	VBL	0	30	V	(1)
Control Signal Level	—	-0.3	7	V	(1), (3)

Note (1) Permanent damage to the device may occur if maximum values are exceeded. Function operation should be restricted to the conditions described under Normal Operating Conditions.

Note (2) No moisture condensation or freezing.

Note (3) The control signals include On/Off Control and Internal PWM Control.

3. ELECTRICAL CHARACTERISTICS**3.1 TFT LCD MODULE (Ta = 25 ± 2 °C)**

Parameter		Symbol	Value			Unit	Note
			Min.	Typ.	Max.		
Power Supply Voltage		V _{CC}	10.8	12	13.2	V	(1)
Rush Current		I _{RUSH}	—	—	5.0	A	(2)
Power Supply Current	White Pattern	—	—	2.3	2.7	A	(3)
	Vertical Stripe	—	—	2.0	—	A	
	Black Pattern	—	-	1.7	—	A	
LVDS interface	Differential Input High Threshold Voltage	V _{LVTH}	+100	—	—	mV	(4)
	Differential Input Low Threshold Voltage	V _{LVTL}	—	—	-100	mV	
	Common Input Voltage	V _{CM}	1.0	1.2	1.4	V	
	Differential input voltage	V _{ID}	100	—	600	mV	
	Terminating Resistor	R _T	—	100	—	ohm	
CMOS interface	Input High Threshold Voltage	V _{IH}	2.7	—	3.3	V	
	Input Low Threshold Voltage	V _{IL}	0	—	0.7	V	

Note (1) The module should be always operated within the above ranges.

Note (2) Measurement condition:

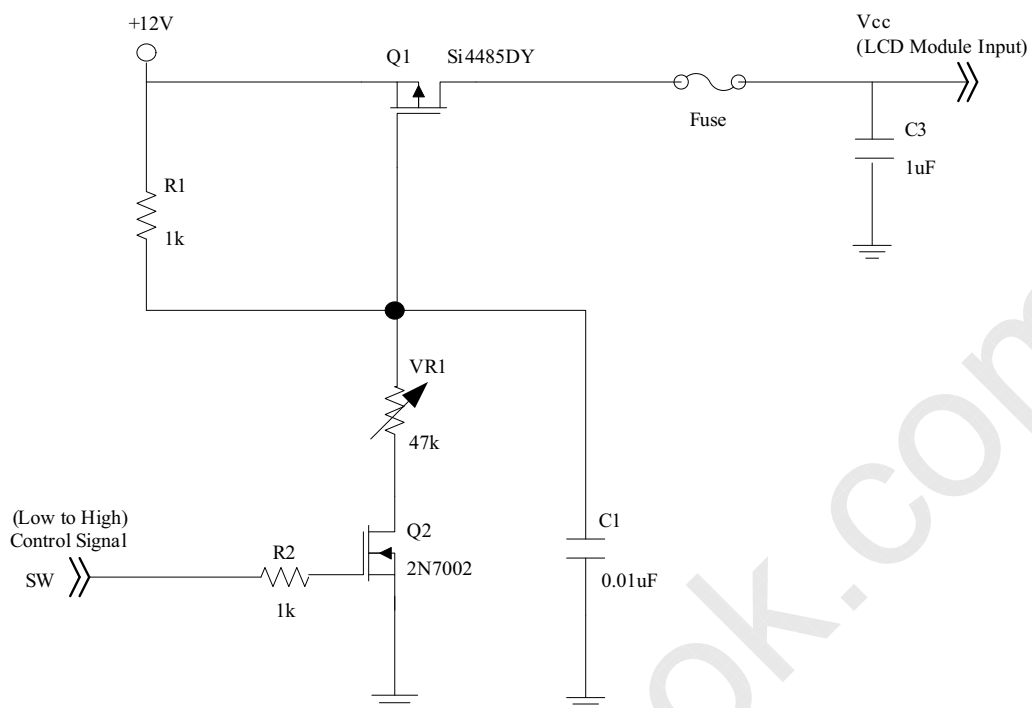

Vcc rising time is 470us

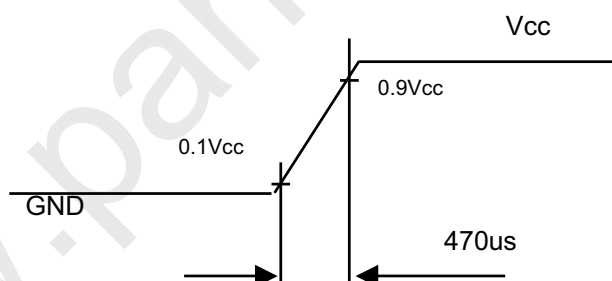

Note (3) The specified power supply current is under the conditions at $V_{CC} = 12\text{ V}$, $T_a = 25 \pm 2\text{ }^\circ\text{C}$, $f_v = 60\text{ Hz}$, whereas a power dissipation check pattern below is displayed.

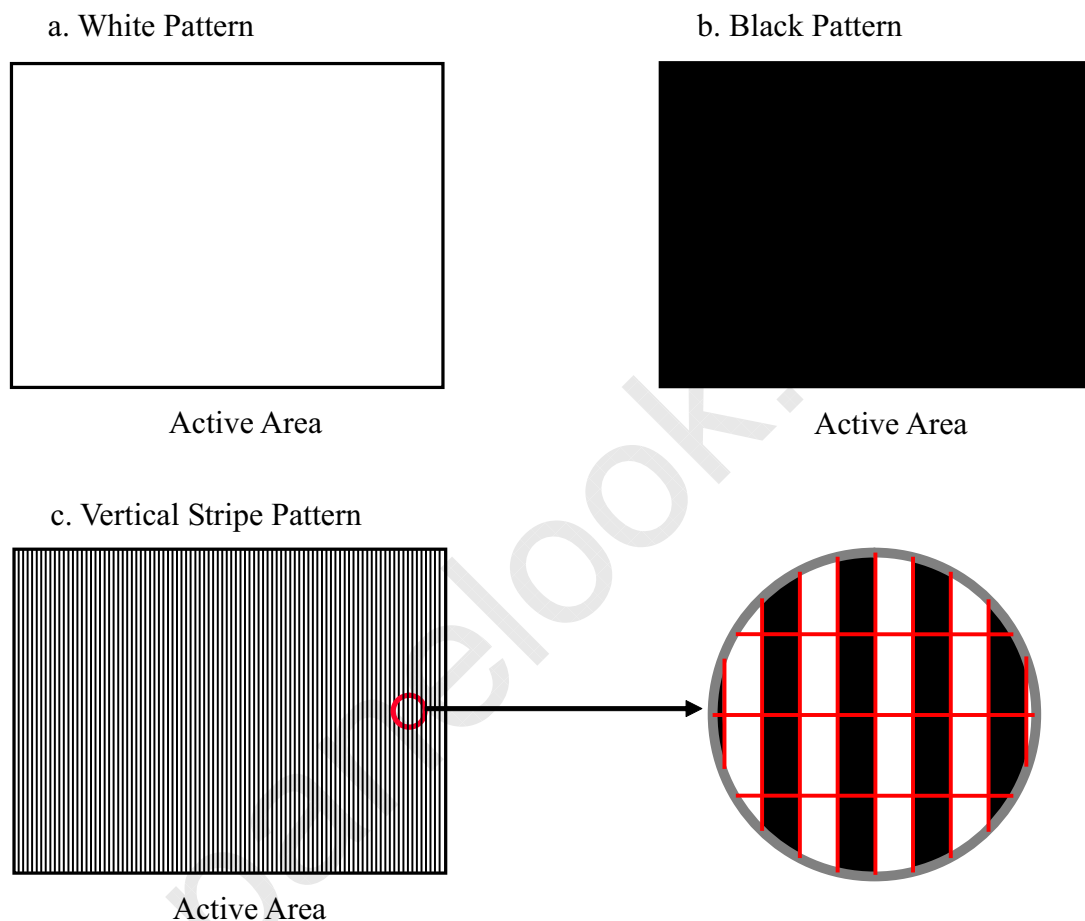

Note (4) The LVDS input characteristics are as follows:

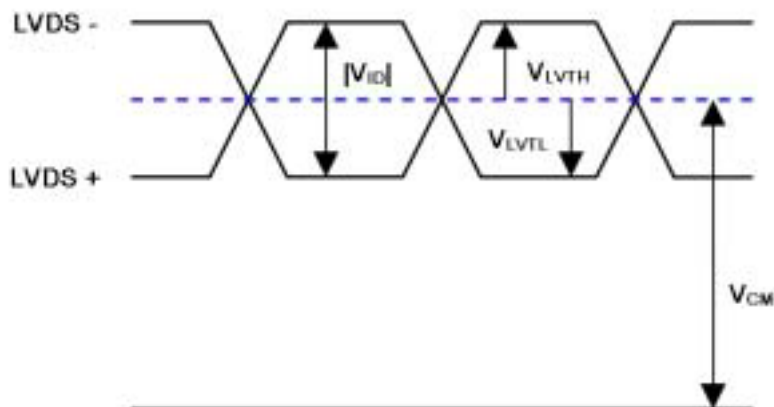

3.2 BACKLIGHT CONNECTOR PIN CONFIGURATION

3.2.1 LAMP SPECIFICATION

(Ta = 25 ± 2 °C)

Parameter	Symbol	Value			Unit	Note
		Min.	Typ.	Max.		
Lamp Input Voltage	VL	-	1090	-	VRMS	-
Lamp Current	IL	9.7	10.2	10.7	mARMS	(1)
Lamp Turn On Voltage	VS	-	-	1910	VRMS	Ta = 0 °C
		-	-	1560	VRMS	Ta = 25 °C
Operating Frequency	FL	35	-	70	KHz	
Lamp Life Time	LBL	50,000	-	-	Hrs	(2)

3.2.2 ELECTRICAL SPECIFICATION

(Ta = 25 ± 2 °C)

Parameter	Symbol	Value			Unit	Note
		Min.	Typ.	Max.		
Power Consumption	P _{BL}	-	130	133	W	(5), IL = 10.2 mA
		-	110	112		(5), IL = 8.7 mA
Power Supply Voltage	V _{BL}	22.8	24.0	25.2	VDC	
Power Supply Current	I _{BL}	-	5.4	-	A	Non Dimming
			4.6			
Input Ripple Noise	-	-	-	912	mVP-P	VBL=22.8V
Oscillating Frequency	F _w	39.5	42.5	45.5	kHz	
Dimming Frequency	F _B	150	160	170	Hz	
Minimum Duty Ratio	D _{MIN}	10	20	-	%	(6)

Note (1) Lamp current is measured by utilizing AC current probe and its value is average by measuring master and slave board. VIPWM : 3V is 100%, V_{ADIM} = HI : Lamp current is 10.2mA; V_{ADIM} = LO : Lamp current is 8.7mA.

Note (2) The lamp starting voltage V_S should be applied to the lamp for more than 1 second after startup. Otherwise the lamp may not be turned on.

Note (3) The lamp frequency may produce interference with horizontal synchronous frequency of the display input signals, and it may result in line flow on the display. In order to avoid interference, the lamp frequency

should be detached from the horizontal synchronous frequency and its harmonics as far as possible.

Note (4) The life time of a lamp is defined as when the brightness is larger than 50% of its original value and the effective discharge length is longer than 80% of its original length (Effective discharge length is defined as an area that has equal to or more than 70% brightness compared to the brightness at the center point of lamp.) as the time in which it continues to operate under the condition at $T_a = 25 \pm 2^\circ\text{C}$ and $I_L = 9.7 \sim 10.7 \text{ mA}$.

Note (5) The measurement condition of Max. value is based on 42" backlight unit under input voltage 24V, average lamp current 10.2 mA and 8.7 mA, lighting 30 minutes later.

Note (6) 10% minimum duty ratio is only valid for electrical operation.

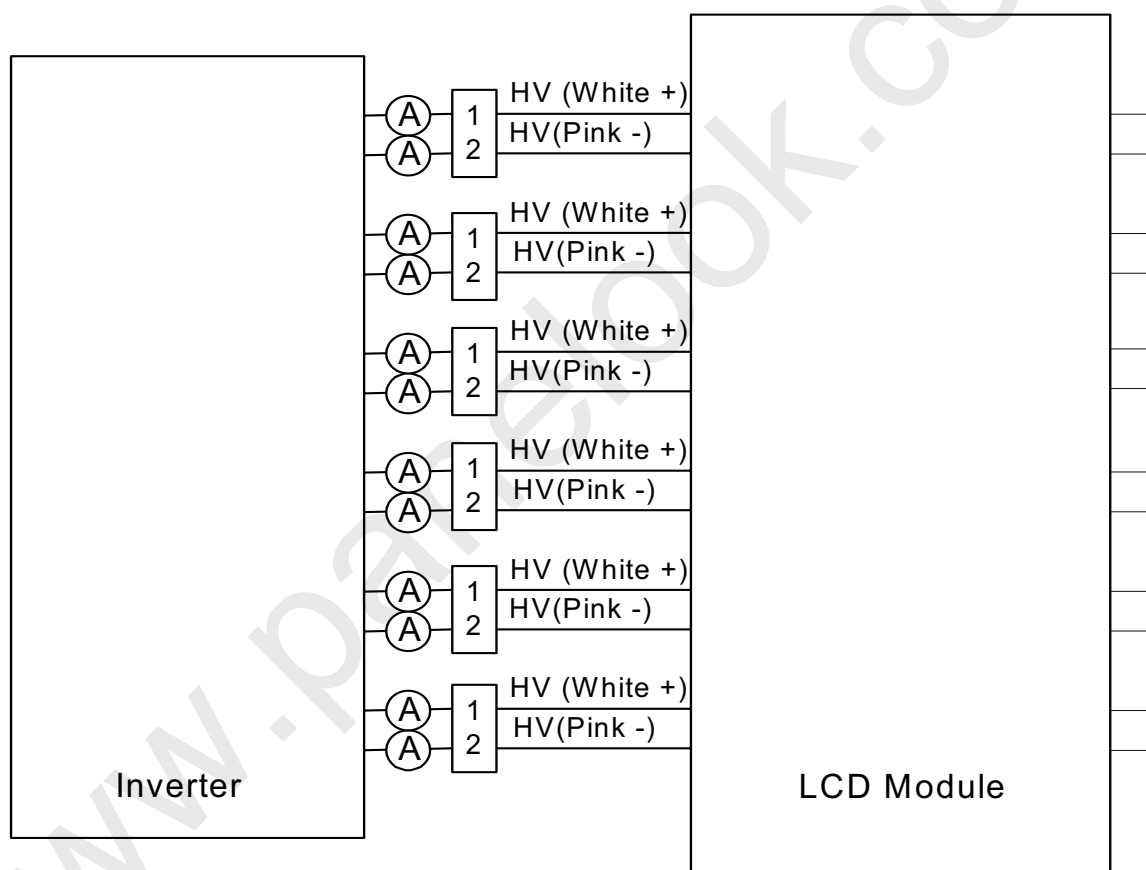

3.2.3 INVERTER INTERFACE CHARACTERISTICS

Parameter		Symbol	Test Condition	Value			Unit	Note
				Min.	Typ.	Max.		
On/Off Control Voltage	ON	V_{BLON}	—	2.0	—	5.0	V	
	OFF		—	0	—	0.8	V	
Internal PWM Control Voltage	MAX	V_{IPWM}	—	2.85	3.0	3.15	V	Max. Duty Ratio
	MIN		—	—	0	—	V	Min. Duty Ratio
Status Signal	HI	Status	—	3.0	3.3	3.6	V	Normal
	LO		—	0	—	0.8	V	Abnormal
VBL Rising Time		$Tr1$	—	30	—	—	ms	10%-90% V_{BL} See as below
VBL Falling Time		$Tf1$	—	30	—	—	ms	
Control Signal Rising Time		Tr	—	—	—	100	ms	
Control Signal Falling Time		Tf	—	—	—	100	ms	
PWM Signal Rising Time		T_{PWMR}	—	—	—	50	us	
PWM Signal Falling Time		T_{PWMF}	—	—	—	50	us	
Input Impedance		R_{IN}	—	1	—	—	MΩ	
PWM Delay Time		T_{PWM}	—	100	—	—	ms	
BLON Delay Time	T_{on}	—	—	300	—	—	ms	
	T_{on1}	—	—	300	—	—		
BLON Off Time		T_{off}	—	300	—	—	ms	

Note (1) The dimming signal should be valid before backlight turns on by BLON signal. It is inhibited to change the internal/external PWM signal during backlight turn on period.

Note (2) The power sequence and control signal timing are shown in the following figure.

Note (3) The power sequence and control signal timing must follow the figure below. For a certain reason, the inverter has a possibility to be damaged with wrong power sequence and control signal timing.

Turn ON sequence: VBL → PWM signal → BLON

Turn OFF sequence: BLOFF → PWM signal → VBL

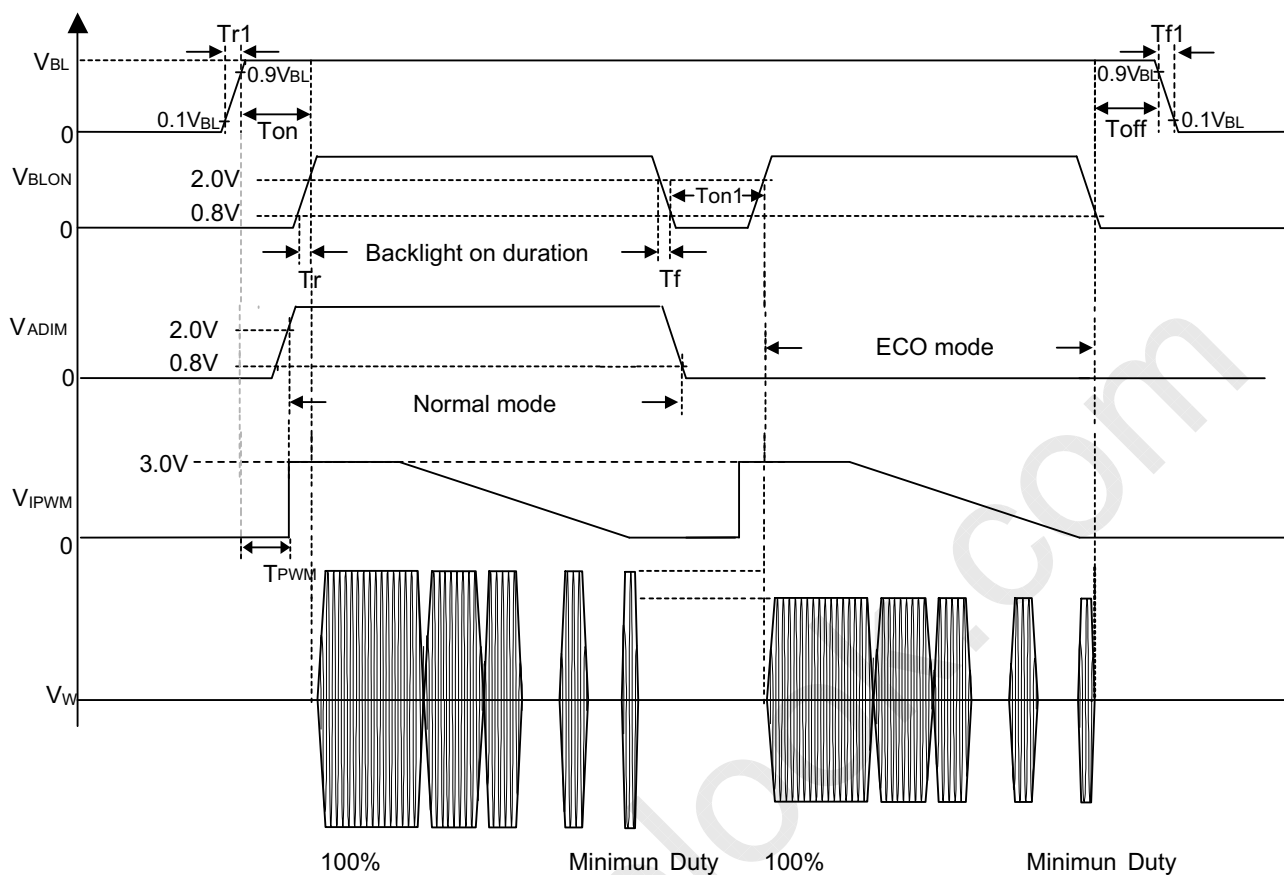

4. BLOCK DIAGRAM OF INTERFACE

4.1 TFT LCD MODULE

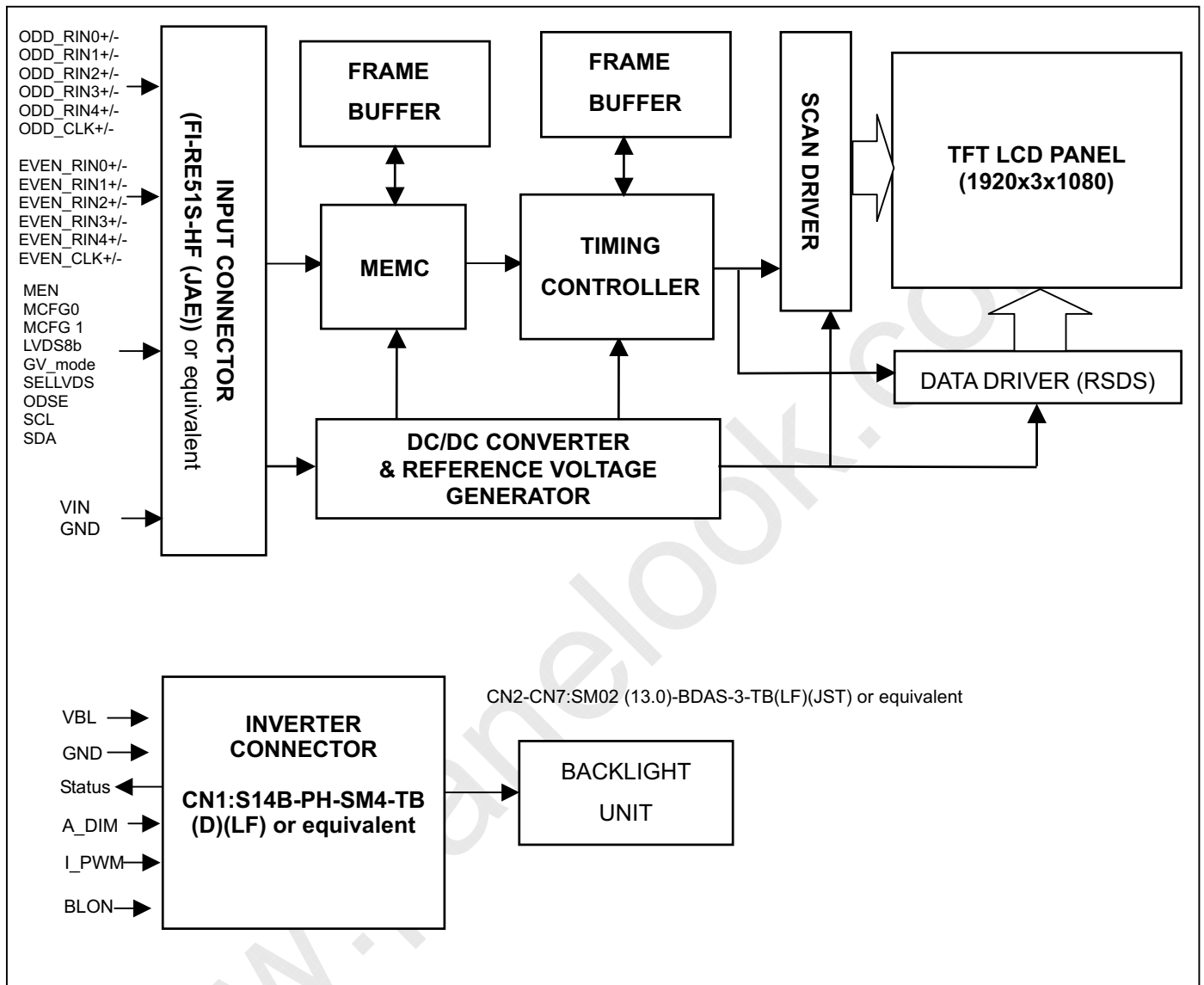

5. INPUT TERMINAL PIN ASSIGNMENT

5.1 TFT LCD Module Input

CNF1 Connector Part No.: JAE Taiwan (台灣航空電子) FI-RE51S-HF or equivalent.

Pin	Name	Description	Note
1	GND	Ground	
2	MEN	MEMC function selection	5
3	MCFG0	MEMC function selection	5
4	MCFG1	MEMC function selection	5
5	LVDS8b	8bit/10bit LVDS input selection	6
6	GV_mode	Graphic / Video mode selection	7
7	SELLVDS	LVDS data format Selection	3
8	SCL	I2C CLK Signal	
9	SDA.	I2C Data Signal	
10	ODSEL	Overdrive Lookup Table Selection	4
11	GND	Ground	
12	ERX0-	2nd pixel Negative LVDS differential data input. Channel 0	
13	ERX0+	2nd pixel Positive LVDS differential data input. Channel 0	
14	ERX1-	2nd pixel Negative LVDS differential data input. Channel 1	
15	ERX1+	2nd pixel Positive LVDS differential data input. Channel 1	
16	ERX2-	2nd pixel Negative LVDS differential data input. Channel 2	
17	ERX2+	2nd pixel Positive LVDS differential data input. Channel 2	
18	GND	Ground	
19	ECLK-	2nd pixel Negative LVDS differential clock input.	
20	ECLK+	2nd pixel Positive LVDS differential clock input.	
21	GND	Ground	
22	ERX3-	2nd pixel Negative LVDS differential data input. Channel 3	
23	ERX3+	2nd pixel Positive LVDS differential data input. Channel 3	
24	ERX4-	2nd pixel Negative LVDS differential data input. Channel 4	
25	ERX4+	2nd pixel Positive LVDS differential data input. Channel 4	
26	N.C.	No Connection	2
27	N.C.	No Connection	2
28	ORX0-	1st pixel Negative LVDS differential data input. Channel 0	
29	ORX0+	1st pixel Positive LVDS differential data input. Channel 0	
30	ORX1-	1st pixel Negative LVDS differential data input. Channel 1	
31	ORX1+	1st pixel Positive LVDS differential data input. Channel 1	
32	ORX2-	1st pixel Negative LVDS differential data input. Channel 2	
33	ORX2+	1st pixel Positive LVDS differential data input. Channel 2	
34	GND	Ground	
35	OCLK-	1st pixel Negative LVDS differential clock input.	
36	OCLK+	1st pixel Positive LVDS differential clock input.	
37	GND	Ground	
38	ORX3-	1st pixel Negative LVDS differential data input. Channel 3	
39	ORX3+	1st pixel Positive LVDS differential data input. Channel 3	
40	ORX4-	1st pixel Negative LVDS differential data input. Channel 4	

41	ORX4+	1st pixel Positive LVDS differential data input. Channel 4	
42	N.C.	No Connection	2
43	N.C.	No Connection	2
44	GND	Ground	
45	GND	Ground	
46	GND	Ground	
47	N.C.	No Connection	2
48	VCC	+12V power supply	
49	VCC	+12V power supply	
50	VCC	+12V power supply	
51	VCC	+12V power supply	

Note (1) LVDS connector pin order defined as follows

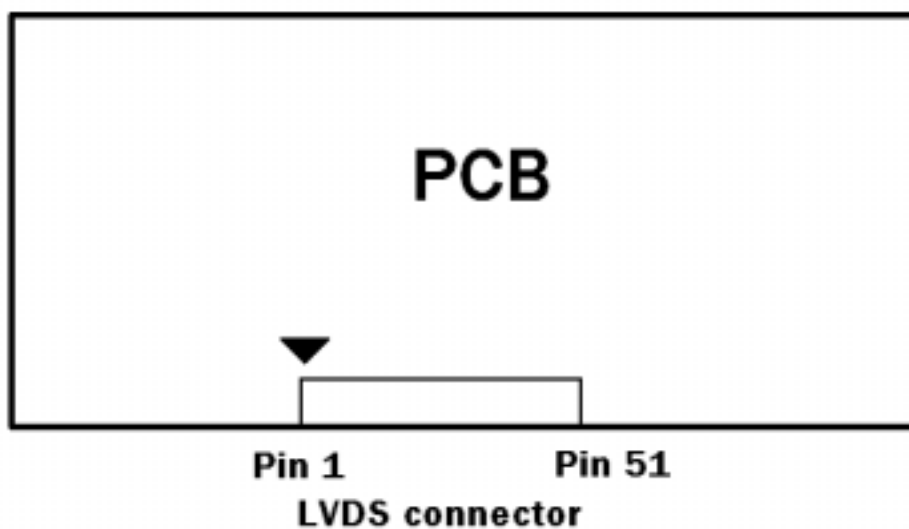

Note (2) Reserved for internal use. Please leave it open

Note (3)

SELLVDS	Mode
L(default)	VESA
H	JEIDA

L: Connect to GND, H: Connect to +3.3V

Note (4) Overdrive lookup table selection. The overdrive lookup table should be selected in accordance with the frame rate to optimize image quality.

ODSEL	Description
L(default)	Lookup table was optimized for 60 Hz frame rate input.
H	Lookup table was optimized for 50 Hz frame rate input.

L: Connect to GND, H: Connect to +3.3V

Note (5) Motion Engine (ME) Level & Demo Function Table

Motion engine level must be adjusted after video mode is selected (or entered).

Adjusting the motion engine level in graphic mode has no effect

		MEN	MCFG1	MCFG0	Notes		
Blanking	Blanking disable	0	0	0	(a)		
	Auto blanking	0	0	1	(b)		
	Blanking enable	0	1	0	(c)		
Effect of ME →					De blur	De judder	Halo
Demo mode (d)		0	1	1	Demo Window		
ME Level	Strong	1	0	0	Enable	Strong	Strong
	Medium(Default)	1	0	1	Enable	Normal	Normal
	Weak	1	1	0	Enable	×	×
	OFF	1	1	1	×	×	×
		(e) (f) (g)					

(a) Module re-starts processing video signals from Frontend scaler control board.

(b) During sync unstable period such as format change, 60Hz <-> 50Hz .

MCFG0 can be used to insert blanking of 500ms. This signal is toggled.

(c) Module continues to insert blanking until blanking disable signal is received from frontend scaler board.

(d) Demo window mode: Demo Window appears to the left half of display area. Left side with frame is 120Hz with MEMC, and right side is 120Hz w/o motion compensation.

(e) GPIO (General Purpose I/O) sequence of ME Level: (1) MEN; (2) MCFG1; (3) MCFG0.

GPIO sequence of Blanking Enable, Blanking Disable and Demo window: (1) MCFG1; (2) MCFG0; (3) MEN.

(f) Each scaler command must be maintained the same voltage level at least 100ms.

(g) 0 : Connect to GND, 1 : +3.3V

Note (6) 8bit/10bit LVDS input selection

LVDS8b	Bit depth
H(default)	8bit
L	10bit

L : Connect to GND, H : Connect to +3.3V

Note (7) Graphic / Video mode selection

There is no prohibited time period for switching between Graphic mode and Video mode.

When this switching signal is input, LCD will be reset and will re-start selected mode.

GV_mode	Mode select	MEMC ON/OFF
H(default)	Graphic mode	MEMC OFF
L	Video mode	MEMC ON

L : Connect to GND, H : Connect to +3.3V

5.2 BACKLIGHT UNIT

The pin configuration for the housing and the leader wire is shown in the table below.

Pin	Name	Description	Wire Color
1	HV	High Voltage	White
2	HV	High Voltage	Pink

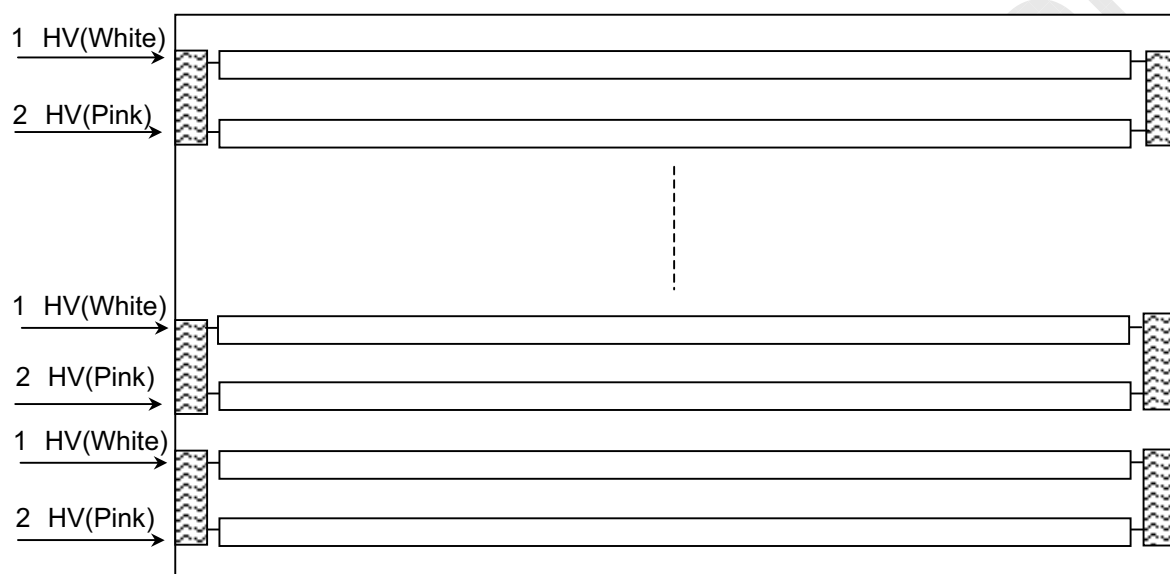

5.3 INVERTER UNIT

CN1: S14B-PH-SM4-TB(D)(LF)(JST) or equivalent

Pin No	Symbol	Feature
1	VBL	+24V
2		
3		
4		
5		
6	GND	GND
7		
8		
9		
10		
11	STATUS	Normal (3.3V) Abnormal(GND)
12	A_DIM	Amplitude Dimming Control HI (2.0V ~ 5.0V) LO(0~0.8V)
13	I_PWM	Internal PWM Control Signal
14	BLON	BL ON/OFF

CN2-CN7: SM02 -BDAS-3-TB(JST) or equivalent

Pin No.	Symbol	Description
1	CCFL HOT	CCFL high voltage
2	CCFL HOT	CCFL high voltage

CN8: 528520870 (Molex) or equivalent

Pin No.	Symbol	Description
1	Control Signal	Board to Board
2		Board to Board
3		Board to Board
4		Board to Board
5		Board to Board
6		Board to Board
7		Board to Board
8		Board to Board

Note (1) Floating of any control signal is not allowed.

5.4 BLOCK DIAGRAM OF INTERFACE

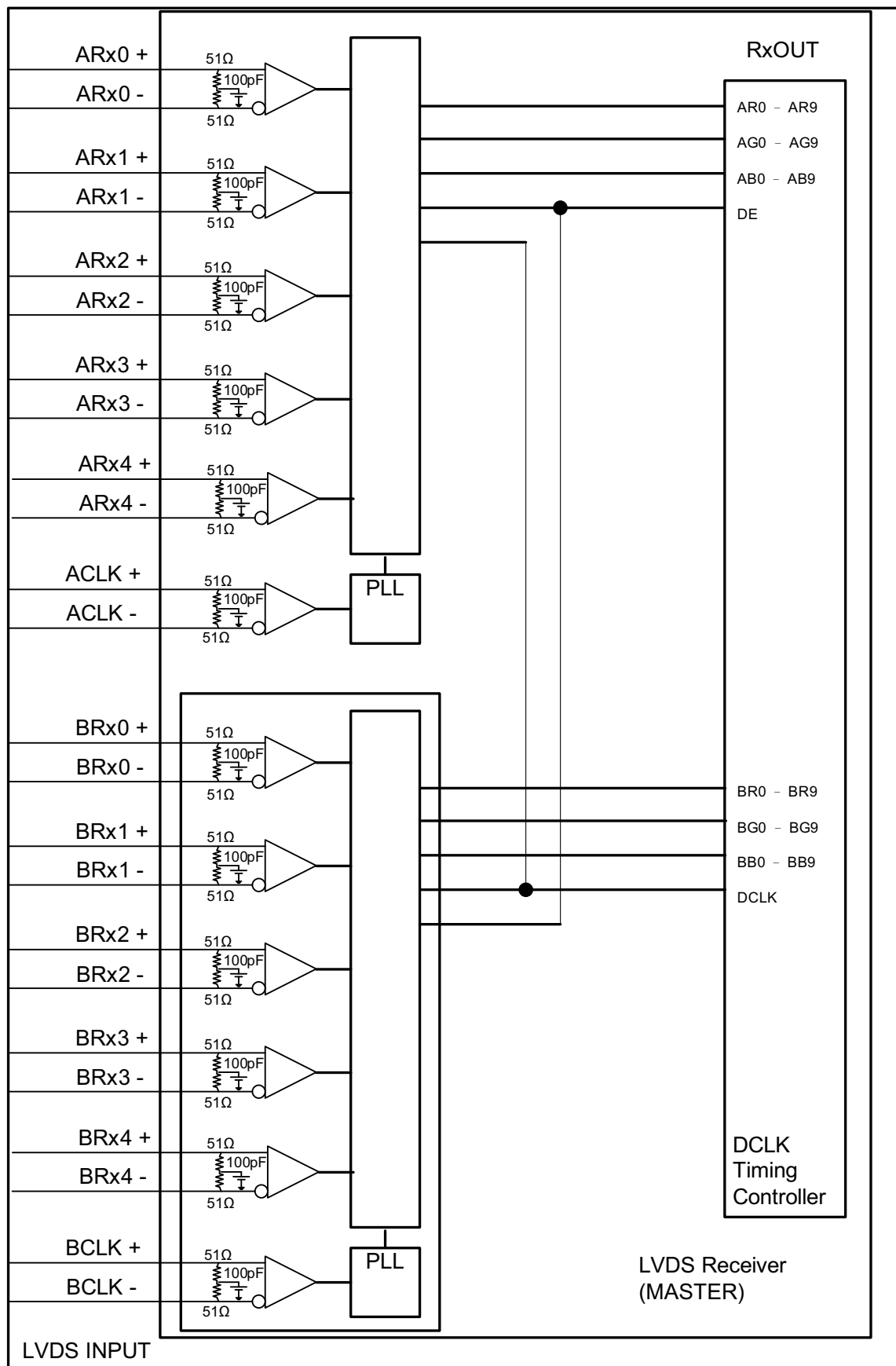

AR0~AR9: First pixel R data

AG0~AG9: First pixel G data

AB0~AB9: First pixel B data

BR0~BR9: Second pixel R data

BG0~BG9: Second pixel G data

BB0~BB9: Second pixel B data

DE: Data enable signal

DCLK: Data clock signal

Notes (1) The system must have the transmitter to drive the module.

Notes (2) LVDS cable impedance shall be 50 ohms per signal line or about 100 ohms per twist-pair line when it is used differentially.

Notes (3) Two pixel data send into the module for every clock cycle. The first pixel of the frame is odd pixel and the second pixel is even pixel.

5.5 LVDS INTERFACE

VESA Format : SELLVDS = L or Open

JEIDA Format : SELLVDS = H

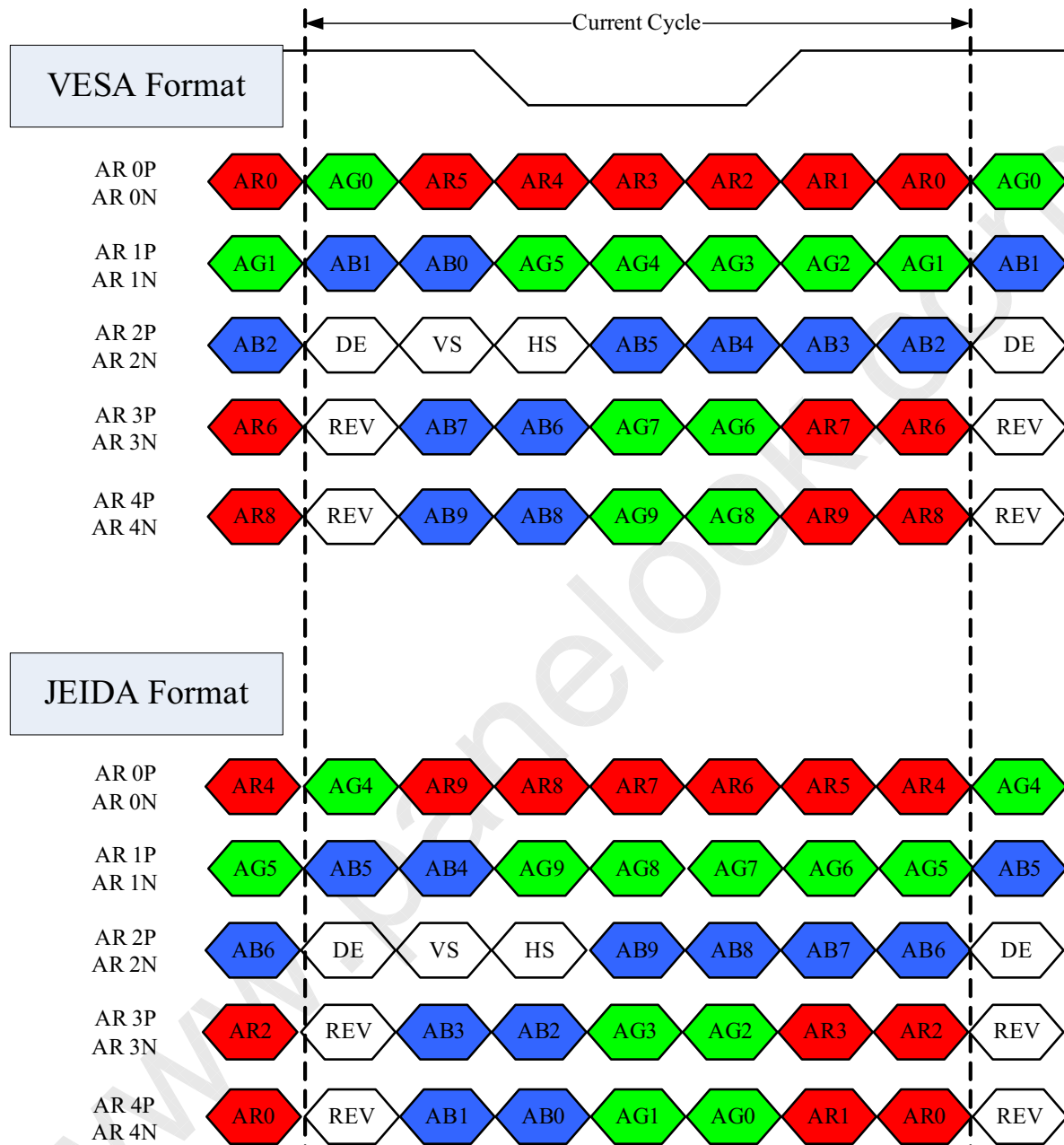

AR0~AR9: First Pixel R Data (9; MSB, 0; LSB)

AG0~AG9: First Pixel G Data (9; MSB, 0; LSB)

AB0~AB9: First Pixel B Data (9; MSB, 0; LSB)

DE : Data enable signal

DCLK : Data clock signal

RSVD : Reserved



5.6 COLOR DATA INPUT ASSIGNMENT

The brightness of each primary color (red, green and blue) is based on the 10-bit gray scale data input for the color. The higher the binary input, the brighter the color. The table below provides the assignment of the color versus data input.

Color		Data Signal																																						
		Red										Green										Blue																		
		R9	R8	R7	R6	R5	R4	R3	R2	R1	R0	G9	G8	G7	G6	G5	G4	G3	G2	G1	G0	B9	B8	B7	B6	B5	B4	B3	B2	B1	B0									
Basic Colors	Black	0	0	0	0	0	0	0	0	0	0	0	0	0	0	0	0	0	0	0	0	0	0	0	0	0	0	0	0	0	0	0	0	0	0	0	0	0	0	0
	Red	1	1	1	1	1	1	1	1	1	1	0	0	0	0	0	0	0	0	0	0	0	0	0	0	0	0	0	0	0	0	0	0	0	0	0	0	0	0	0
	Green	0	0	0	0	0	0	0	0	0	0	1	1	1	1	1	1	1	1	1	0	0	0	0	0	0	0	0	0	0	0	0	0	0	0	0	0	0	0	0
	Blue	0	0	0	0	0	0	0	0	0	0	0	0	0	0	0	0	0	0	0	0	0	0	0	0	0	0	0	0	0	1	1	1	1	1	1	1	1	1	1
	Cyan	0	0	0	0	0	0	0	0	0	0	1	1	1	1	1	1	1	1	1	1	1	1	1	1	1	1	1	1	1	0	0	0	0	0	0	0	0	0	0
	Magenta	1	1	1	1	1	1	1	1	1	1	0	0	0	0	0	0	0	0	0	0	0	0	0	0	0	0	0	0	0	1	1	1	1	1	1	1	1	1	1
	Yellow	1	1	1	1	1	1	1	1	1	1	1	1	1	1	1	1	1	1	1	1	1	1	1	1	1	1	1	1	1	0	0	0	0	0	0	0	0	0	0
White	1	1	1	1	1	1	1	1	1	1	1	1	1	1	1	1	1	1	1	1	1	1	1	1	1	1	1	1	1	1	1	1	1	1	1	1	1	1	1	
Gray Scale Of Red	Red (0) / Dark	0	0	0	0	0	0	0	0	0	0	0	0	0	0	0	0	0	0	0	0	0	0	0	0	0	0	0	0	0	0	0	0	0	0	0	0	0	0	
	Red (1)	0	0	0	0	0	0	0	0	0	1	0	0	0	0	0	0	0	0	0	0	0	0	0	0	0	0	0	0	0	0	0	0	0	0	0	0	0	0	
	Red (2)	0	0	0	0	0	0	0	0	1	0	0	0	0	0	0	0	0	0	0	0	0	0	0	0	0	0	0	0	0	0	0	0	0	0	0	0	0	0	
	⋮	⋮	⋮	⋮	⋮	⋮	⋮	⋮	⋮	⋮	⋮	⋮	⋮	⋮	⋮	⋮	⋮	⋮	⋮	⋮	⋮	⋮	⋮	⋮	⋮	⋮	⋮	⋮	⋮	⋮	⋮	⋮	⋮	⋮	⋮	⋮	⋮	⋮	⋮	
	Red (1021)	1	1	1	1	1	1	1	1	0	1	0	0	0	0	0	0	0	0	0	0	0	0	0	0	0	0	0	0	0	0	0	0	0	0	0	0	0	0	
	Red (1022)	1	1	1	1	1	1	1	1	1	0	0	0	0	0	0	0	0	0	0	0	0	0	0	0	0	0	0	0	0	0	0	0	0	0	0	0	0	0	
	Red (1023)	1	1	1	1	1	1	1	1	1	1	0	0	0	0	0	0	0	0	0	0	0	0	0	0	0	0	0	0	0	0	0	0	0	0	0	0	0	0	
Gray Scale Of Green	Green (0) / Dark	0	0	0	0	0	0	0	0	0	0	0	0	0	0	0	0	0	0	0	0	0	0	0	0	0	0	0	0	0	0	0	0	0	0	0	0	0	0	
	Green (1)	0	0	0	0	0	0	0	0	0	0	0	0	0	0	0	0	0	0	0	0	0	0	0	0	0	0	0	0	0	0	0	0	0	0	0	0	0	0	
	Green (2)	0	0	0	0	0	0	0	0	0	0	0	0	0	0	0	0	0	0	0	0	0	0	0	0	0	0	0	0	0	0	0	0	0	0	0	0	0	0	
	⋮	⋮	⋮	⋮	⋮	⋮	⋮	⋮	⋮	⋮	⋮	⋮	⋮	⋮	⋮	⋮	⋮	⋮	⋮	⋮	⋮	⋮	⋮	⋮	⋮	⋮	⋮	⋮	⋮	⋮	⋮	⋮	⋮	⋮	⋮	⋮	⋮	⋮	⋮	
	Green (1021)	0	0	0	0	0	0	0	0	0	0	1	1	1	1	1	1	1	1	0	0	0	0	0	0	0	0	0	0	0	0	0	0	0	0	0	0	0	0	
	Green (1022)	0	0	0	0	0	0	0	0	0	0	1	1	1	1	1	1	1	1	0	0	0	0	0	0	0	0	0	0	0	0	0	0	0	0	0	0	0	0	
	Green (1023)	0	0	0	0	0	0	0	0	0	0	1	1	1	1	1	1	1	1	0	0	0	0	0	0	0	0	0	0	0	0	0	0	0	0	0	0	0	0	
Gray Scale Of Blue	Blue (0) / Dark	0	0	0	0	0	0	0	0	0	0	0	0	0	0	0	0	0	0	0	0	0	0	0	0	0	0	0	0	0	0	0	0	0	0	0	0	0	0	
	Blue (1)	0	0	0	0	0	0	0	0	0	0	0	0	0	0	0	0	0	0	0	0	0	0	0	0	0	0	0	0	0	0	0	0	0	0	0	0	0	1	
	Blue (2)	0	0	0	0	0	0	0	0	0	0	0	0	0	0	0	0	0	0	0	0	0	0	0	0	0	0	0	0	0	0	0	0	0	0	0	0	0	1	
	⋮	⋮	⋮	⋮	⋮	⋮	⋮	⋮	⋮	⋮	⋮	⋮	⋮	⋮	⋮	⋮	⋮	⋮	⋮	⋮	⋮	⋮	⋮	⋮	⋮	⋮	⋮	⋮	⋮	⋮	⋮	⋮	⋮	⋮	⋮	⋮	⋮	⋮	⋮	
	Blue (1021)	0	0	0	0	0	0	0	0	0	0	0	0	0	0	0	0	0	0	0	0	0	0	0	0	0	0	0	0	1	1	1	1	1	1	1	1	1	0	
	Blue (1022)	0	0	0	0	0	0	0	0	0	0	0	0	0	0	0	0	0	0	0	0	0	0	0	0	0	0	0	0	1	1	1	1	1	1	1	1	1	0	
	Blue (1023)	0	0	0	0	0	0	0	0	0	0	0	0	0	0	0	0	0	0	0	0	0	0	0	0	0	0	0	0	1	1	1	1	1	1	1	1	1	1	

Note (1) 0: Low Level Voltage, 1: High Level Voltage

6. INTERFACE TIMING

6.1 INPUT SIGNAL TIMING SPECIFICATIONS

The input signal timing specifications are shown as the following table and timing diagram.

Signal	Item	Symbol	Min.	Typ.	Max.	Unit	Note
LVDS Receiver Clock	Frequency	$F_{clk_{in}}$ ($=1/TC$)	60	74.25	78	MHz	
	Input cycle to cycle jitter	T_{rc1}	—	—	200	ps	(2)
	Spread spectrum modulation range	$F_{clk_{in_mod}}$	$F_{clk_{in}}-2\%$	—	$F_{clk_{in}}+2\%$	MHz	(3)
	Spread spectrum modulation frequency	F_{SSM}	30	—	50	KHz	
LVDS Receiver Data	Setup Time	T_{lvsu}	600	—	—	ps	
	Hold Time	T_{lvhd}	600	—	—	ps	
Vertical Active Display Term	Frame Rate	F_{r5}	47	50	53	Hz	
		F_{r6}	57	60	62	Hz	
	Total	T_v	1110	1125	1135	Th	$T_v=T_{vd}+T_{vb}$
	Display	T_{vd}	1080	1080	1080	Th	
	Blank	T_{vb}	30	45	55	Th	
Horizontal Active Display Term	Total	T_h	1050	1100	1150	Tc	$T_h=T_{hd}+T_{hb}$
	Display	T_{hd}	960	960	960	Tc	
	Blank	T_{hb}	90	140	190	Tc	

Note (1) Please make sure the range of frame rate has follow the below equation :

$$Fr(\max) \geq F_{clk_{in}} / T_v \times T_h \leq Fr(\min)$$

Note (2) The input clock cycle-to-cycle jitter is defined as below figures. $Trc1 = |T_1 - T_2|$

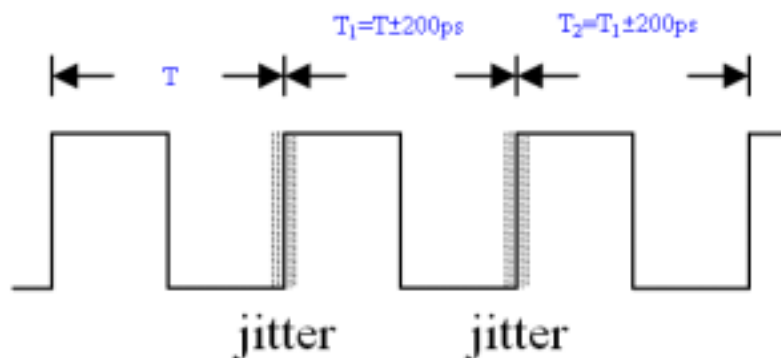

Note (3) The SSCG (Spread spectrum clock generator) is defined as below figures.

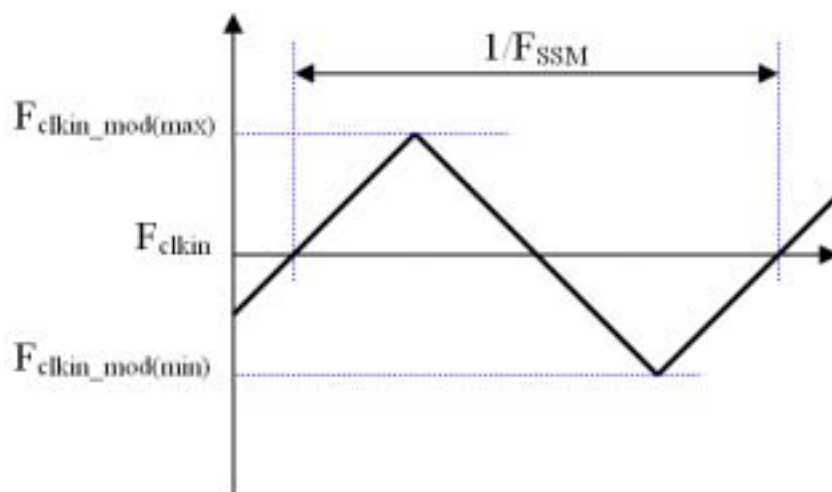

www.panelook.com

6.2 POWER ON/OFF SEQUENCE

To prevent a latch-up or DC operation of LCD module, the power on/off sequence should follow the diagram below.

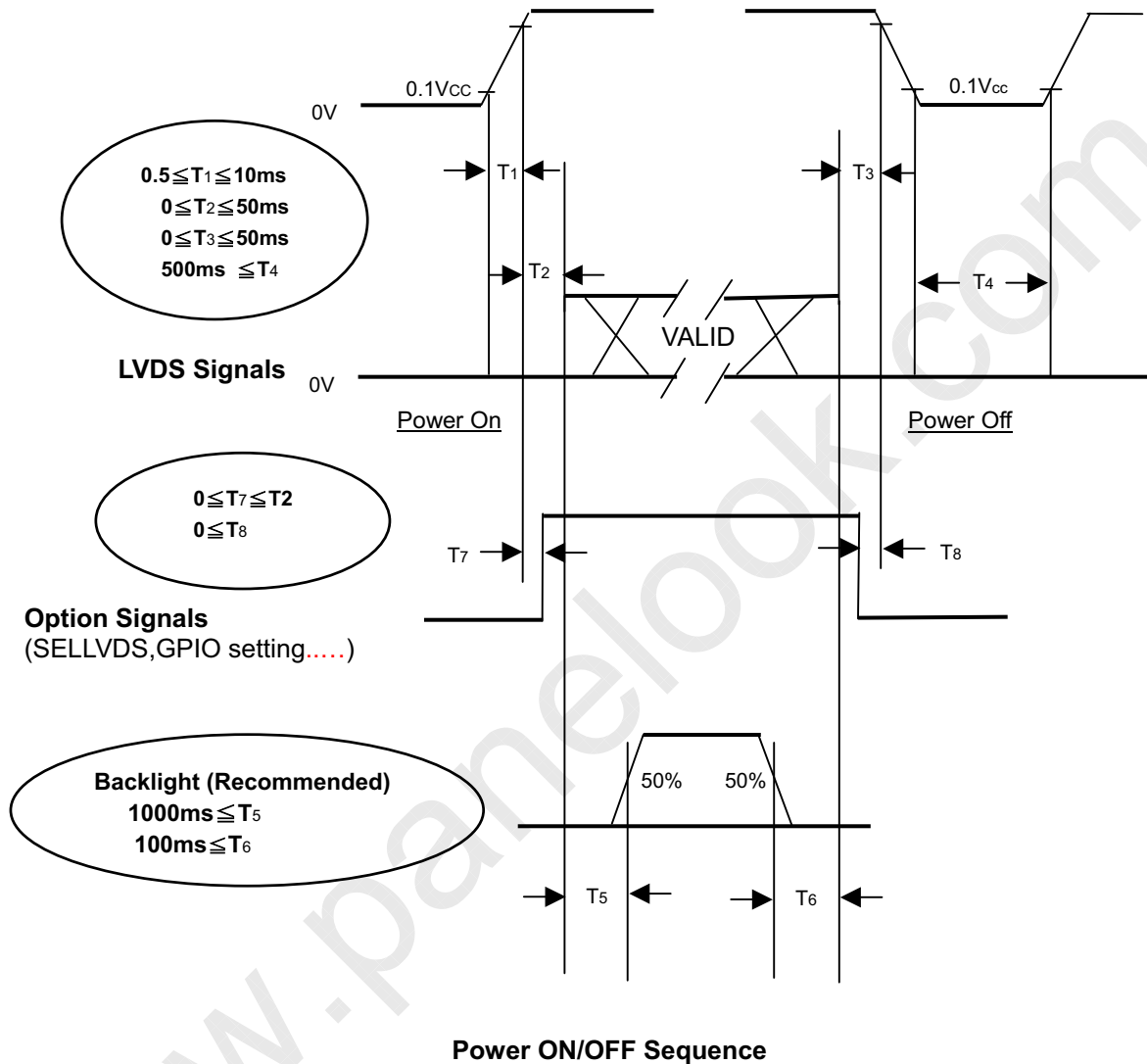

Note:

- (1) The supply voltage of the external system for the module input should follow the definition of Vcc.
- (2) Apply the lamp voltage within the LCD operation range. When the backlight turns on before the LCD operation or the LCD turns off before the backlight turns off, the display may momentarily become abnormal screen.
- (3) In case of VCC is in off level, please keep the level of input signals on the low or high impedance.
- (4) T4 should be measured after the module has been fully discharged between power off and on period.
- (5) Interface signal shall not be kept at high impedance when the power is on.

7. OPTICAL CHARACTERISTICS

7.1 TEST CONDITIONS

Item	Symbol	Value	Unit
Ambient Temperature	Ta	25±2	oC
Ambient Humidity	Ha	50±10	%RH
Supply Voltage	VCC	12	V
Input Signal	According to typical value in "3. ELECTRICAL CHARACTERISTICS"		
Lamp Current	IL	8.7/10.2	mA
Oscillating Frequency (Inverter)	FW	42±3	KHz
Vertical Frame Rate	Fr	120	Hz

The LCD module should be stabilized at given temperature for 1 hour to avoid abrupt temperature change during measuring. In order to stabilize the luminance, the measurement (CS-1000 or CA-210 calibrated by CS-1000) should be executed after lighting backlight for 1 hour in a windless room.

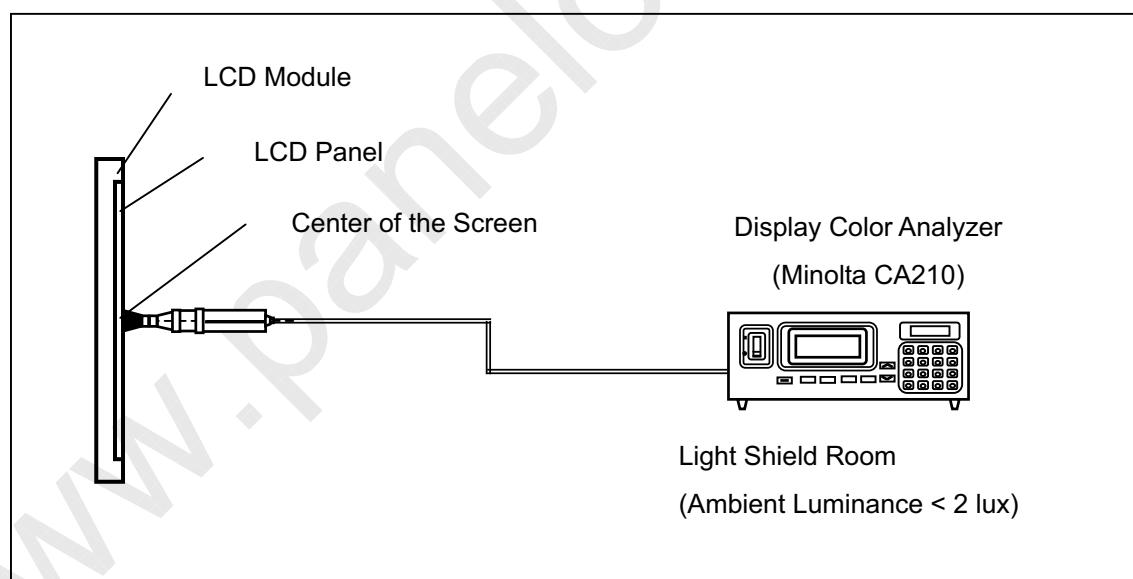

7.2 OPTICAL SPECIFICATIONS

The relative measurement methods of optical characteristics are shown in 7.2. The following items should be measured under the test conditions described in 7.1 and stable environment shown in 7.1.

Item		Symbol	Condition	Min.	Typ.	Max.	Unit	Note
Contrast Ratio		CR		3000	4000	-	-	Note (2)
Response Time		Gray to gray		-	4.0	8.0	ms	Note (3)
Center Luminance of White	Noraml mode	LC		400	500	-	cd/m ²	Note (4)
	ECO mode	LC		350	450	-	cd/m ²	Note (4), (7)
White Variation		δW		-	-	1.3	-	Note (6)
Cross Talk		CT		-	-	4	%	Note (5)
Color Chromaticity	Red	Rx	$\theta x=0^\circ, \theta y=0^\circ$ Viewing angle at normal direction	Typ. -0.03	0.649	Typ. +0.03	-	-
		Ry			0.334		-	
	Green	Gx			0.267		-	
		Gy			0.610		-	
	Blue	Bx			0.149		-	
		By			0.060		-	
	White	Wx			0.280		-	
		Wy			0.285		-	
	Color Gamut				C.G		-	
Viewing Angle	Horizontal	$\theta x+$	CR \geq 20	80	88	-	Deg.	Note (1)
		$\theta x-$		80	88	-		
	Vertical	$\theta Y+$		80	88	-		
		$\theta Y-$		80	88	-		

Note (1) Definition of Viewing Angle ($\theta x, \theta y$):

Viewing angles are measured by Eldim EZ-Contrast 160R

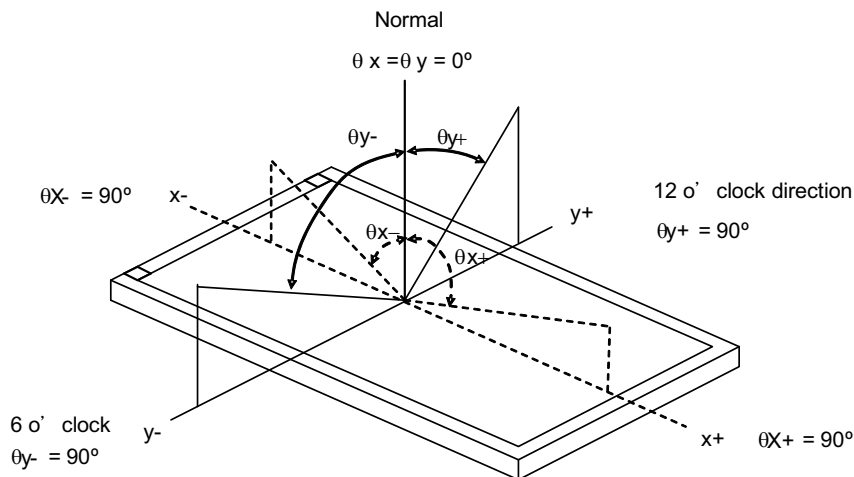
**Note (2) Definition of Contrast Ratio (CR):**

The contrast ratio can be calculated by the following expression.

$$\text{Contrast Ratio (CR)} = \frac{\text{Surface Luminance with all white pixels}}{\text{Surface Luminance with all black pixels}}$$

CR = CR (X), where CR (X) is corresponding to the Contrast Ratio of the point X at the figure in Note (6).

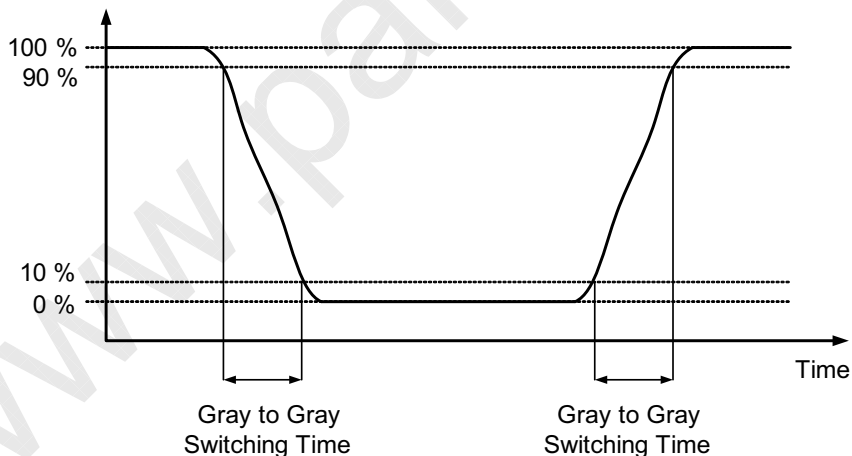
Note (3) Definition of Gray-to-Gray Switching Time:**Optical Response**

The driving signal means the signal of gray level 0, 124, 252, 380, 508, 636, 764, 892 and 1023.

Gray to gray average time means the average switching time of gray level 0, 124, 252, 380, 508, 636, 764, 892, 1023 to each other.

Note (4) Definition of Luminance of White (L_C , L_{AVE}):

Measure the luminance of gray level 1023 at center point and 5 points

$L_C = L (5)$, where $L (X)$ is corresponding to the luminance of the point X at the figure in Note (6).

Note (5) Definition of Cross Talk (CT):

$$CT = |Y_B - Y_A| / Y_A \times 100 (\%)$$

Where:

Y_A = Luminance of measured location without gray level 0 pattern (cd/m²)

Y_B = Luminance of measured location with gray level 0 pattern (cd/m²)

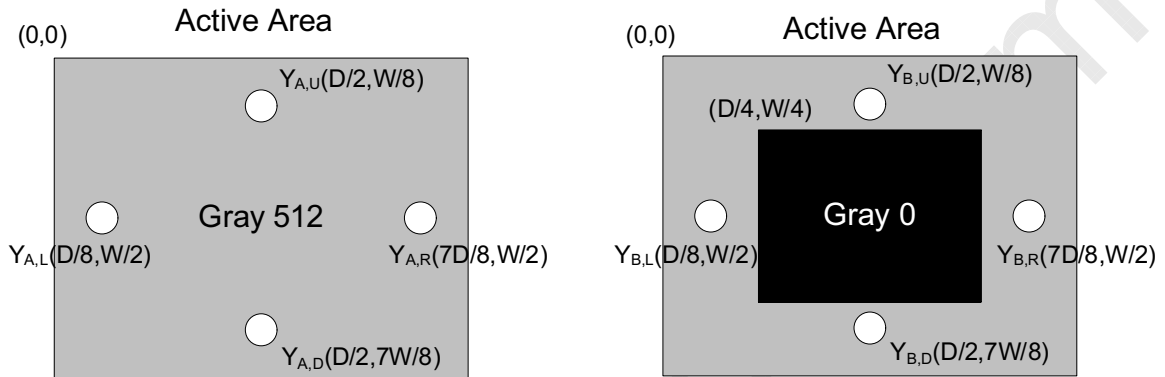

Note (6) Definition of White Variation (δW):

Measure the luminance of gray level 1023 at 5 points

$$\delta W = \text{Maximum} [L(1), L(2), L(3), L(4), L(5)] / \text{Minimum} [L(1), L(2), L(3), L(4), L(5)]$$

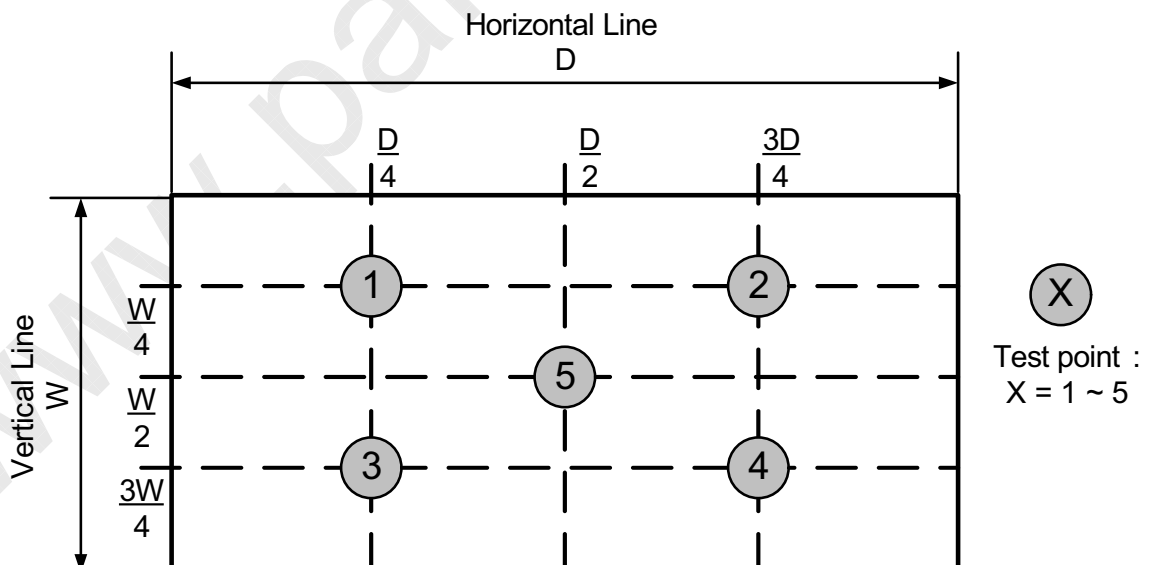

Note (7) ECO mode:

ECO mode was selected by inverter pin: A_DIM.

8. PRECAUTIONS

8.1 ASSEMBLY AND HANDLING PRECAUTIONS

- [1] Do not apply rough force such as bending or twisting to the module during assembly.
- [2] It is recommended to assemble or to install a module into the user's system in clean working areas. The dust and oil may cause electrical short or worsen the polarizer.
- [3] Do not apply pressure or impulse to the module to prevent the damage of LCD panel and Backlight.
- [4] Always follow the correct power-on sequence when the LCD module is turned on. This can prevent the damage and latch-up of the CMOS LSI chips.
- [5] Do not plug in or pull out the I/F connector while the module is in operation.
- [6] Do not disassemble the module.
- [7] Use a soft dry cloth without chemicals for cleaning, because the surface of polarizer is very soft and easily scratched.
- [8] Moisture can easily penetrate into LCD module and may cause the damage during operation.
- [9] When storing modules as spares for a long time, the following precaution is necessary.
 - [9.1] Do not leave the module in high temperature, and high humidity for a long time. It is highly recommended to store the module with temperature from 0 to 35°C at normal humidity without condensation.
 - [9.2] The module shall be stored in dark place. Do not store the TFT-LCD module in direct sunlight or fluorescent light.
- [10] When ambient temperature is lower than 10°C, the display quality might be reduced. For example, the response time will become slow, and the starting voltage of CCFL will be higher than that of room temperature.

8.2 SAFETY PRECAUTIONS

- [1] The startup voltage of a Backlight is approximately 1000 Volts. It may cause an electrical shock while assembling with the inverter. Do not disassemble the module or insert anything into the Backlight unit.
- [2] If the liquid crystal material leaks from the panel, it should be kept away from the eyes or mouth. In case of contact with hands, skin or clothes, it has to be washed away thoroughly with soap.
- [3] After the module's end of life, it is not harmful in case of normal operation and storage.

9. DEFINITION OF LABELS

9.1 CMO MODULE LABEL

The barcode nameplate is pasted on each module as illustration, and its definitions are as following explanation.

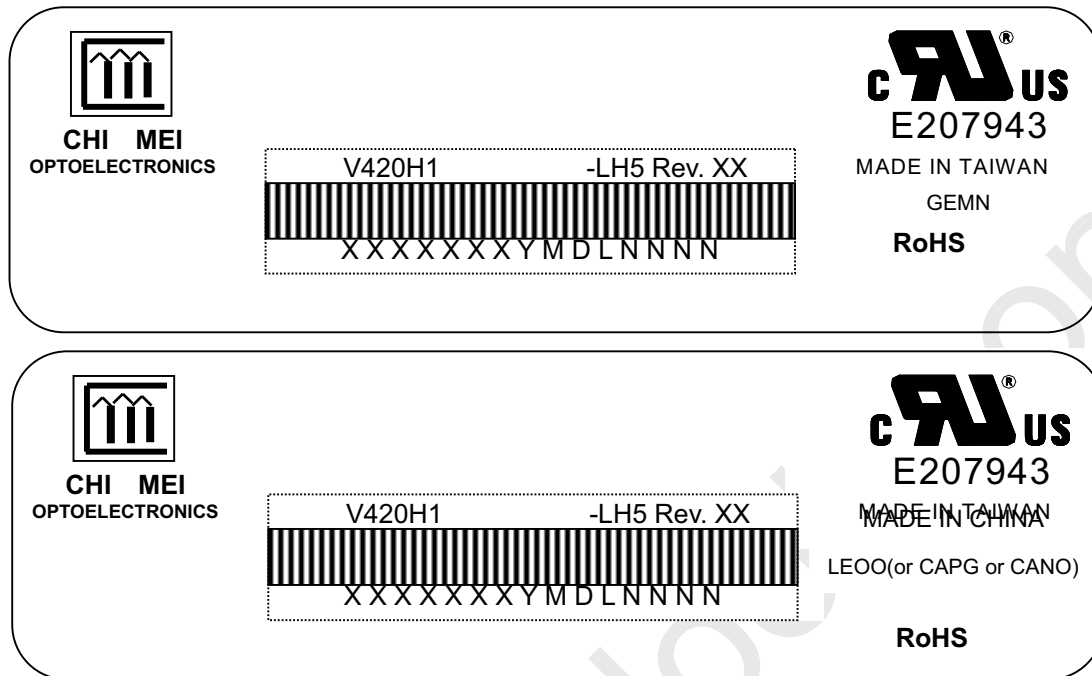

Model Name: V420H1-LH5

Revision: Rev. XX, for example: A0, A1... B1, B2... or C1, C2...etc.

Serial ID: X X X X X X Y M D L N N N N

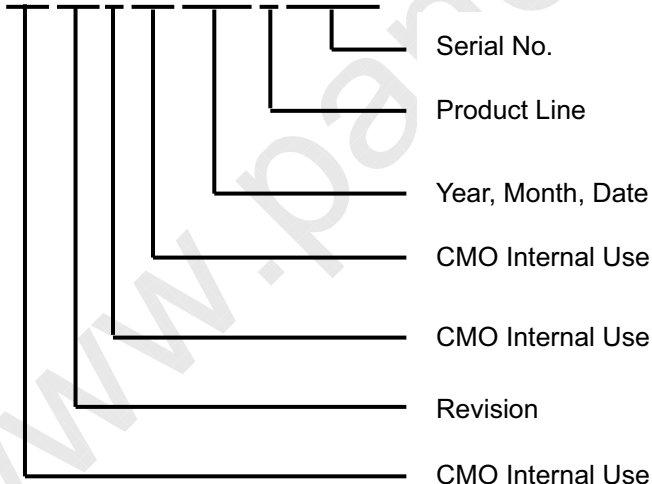

Serial ID includes the information as below:

Manufactured Date:

Year: 0~9, for 2000~2009

Month: 1~9, A~C, for Jan. ~ Dec.

Day: 1~9, A~Y, for 1st to 31st, exclude I, O, and U.

Revision Code: Cover all the change

Serial No.: Manufacturing sequence of product

Product Line: 1 -> Line1, 2 -> Line 2, ...etc.

10. PACKAGING

10.1 PACKAGING SPECIFICATIONS

- (1) 4 LCD TV modules / 1 Box
- (2) Box dimensions : 1085(L)x296(W)x653(H)mm
- (3) Weight : Approx. 45.3Kg(4 modules per carton)

10.2 PACKING METHOD

Figures 10-1 and 10-2 are the packing method

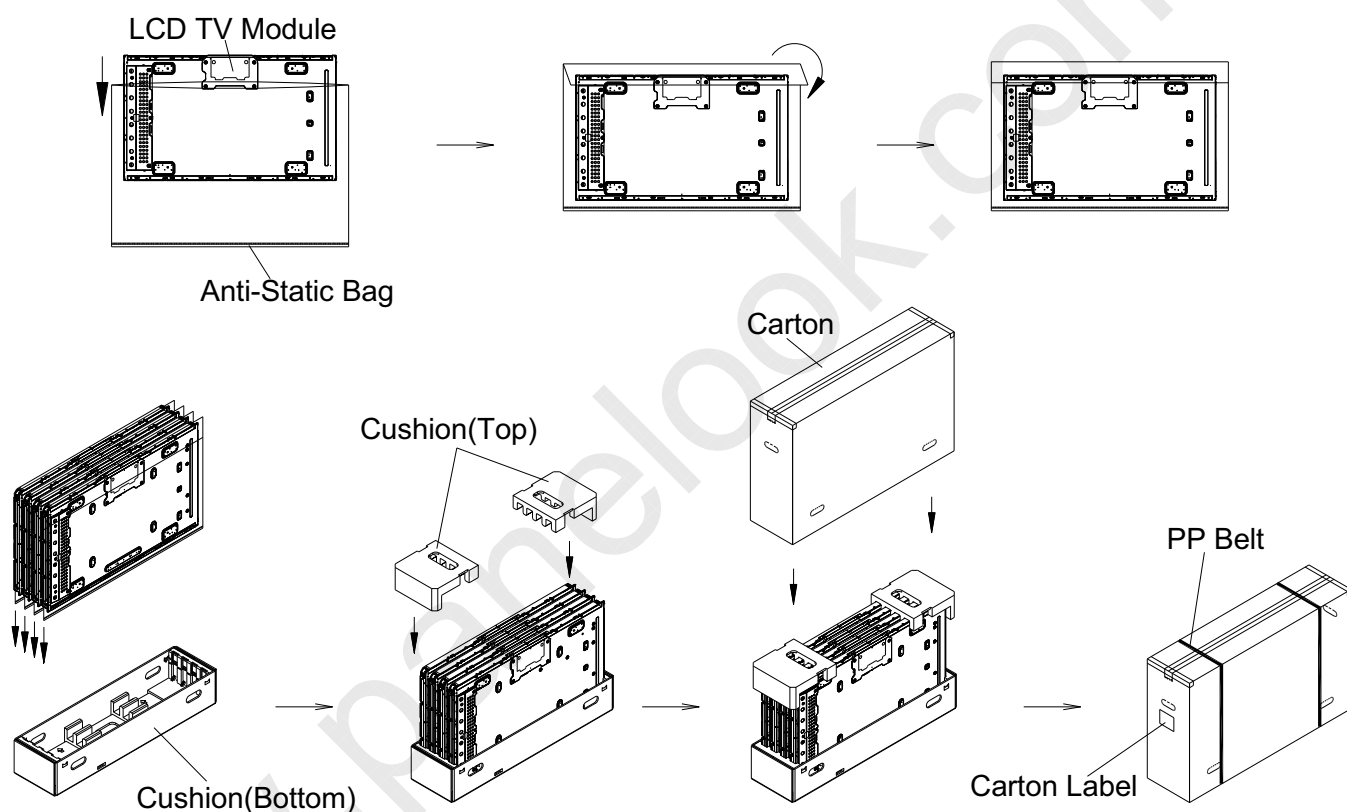

Figure.10-1 packing method



Sea / Land Transportation
(40ft Container)

Air Transportation

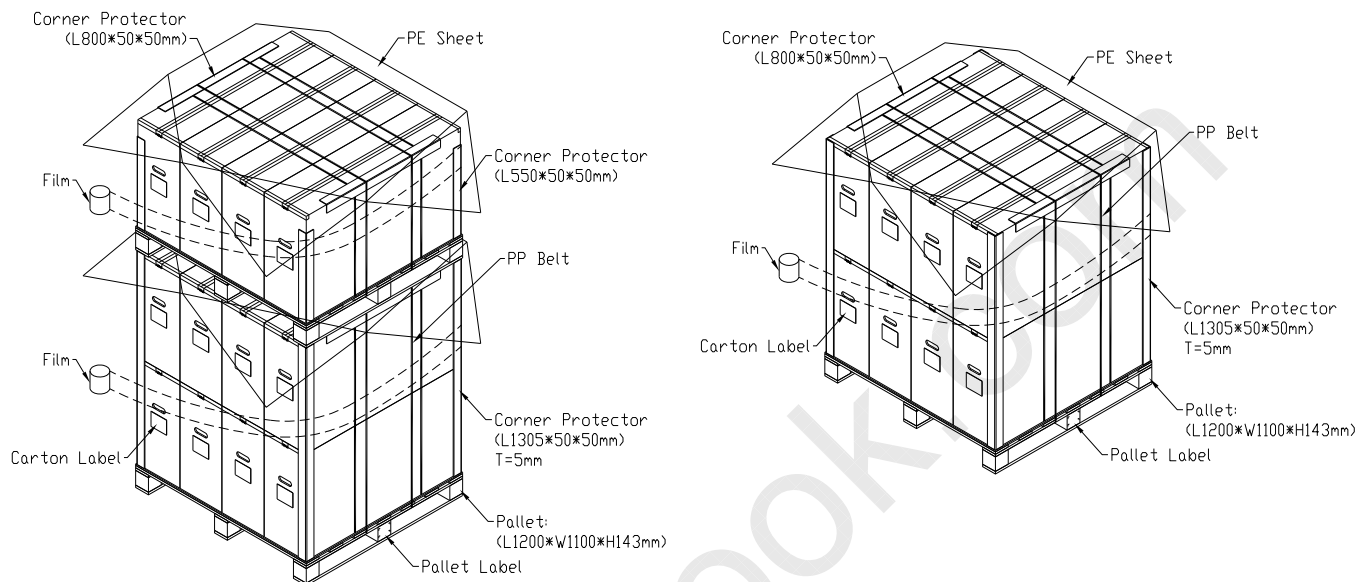
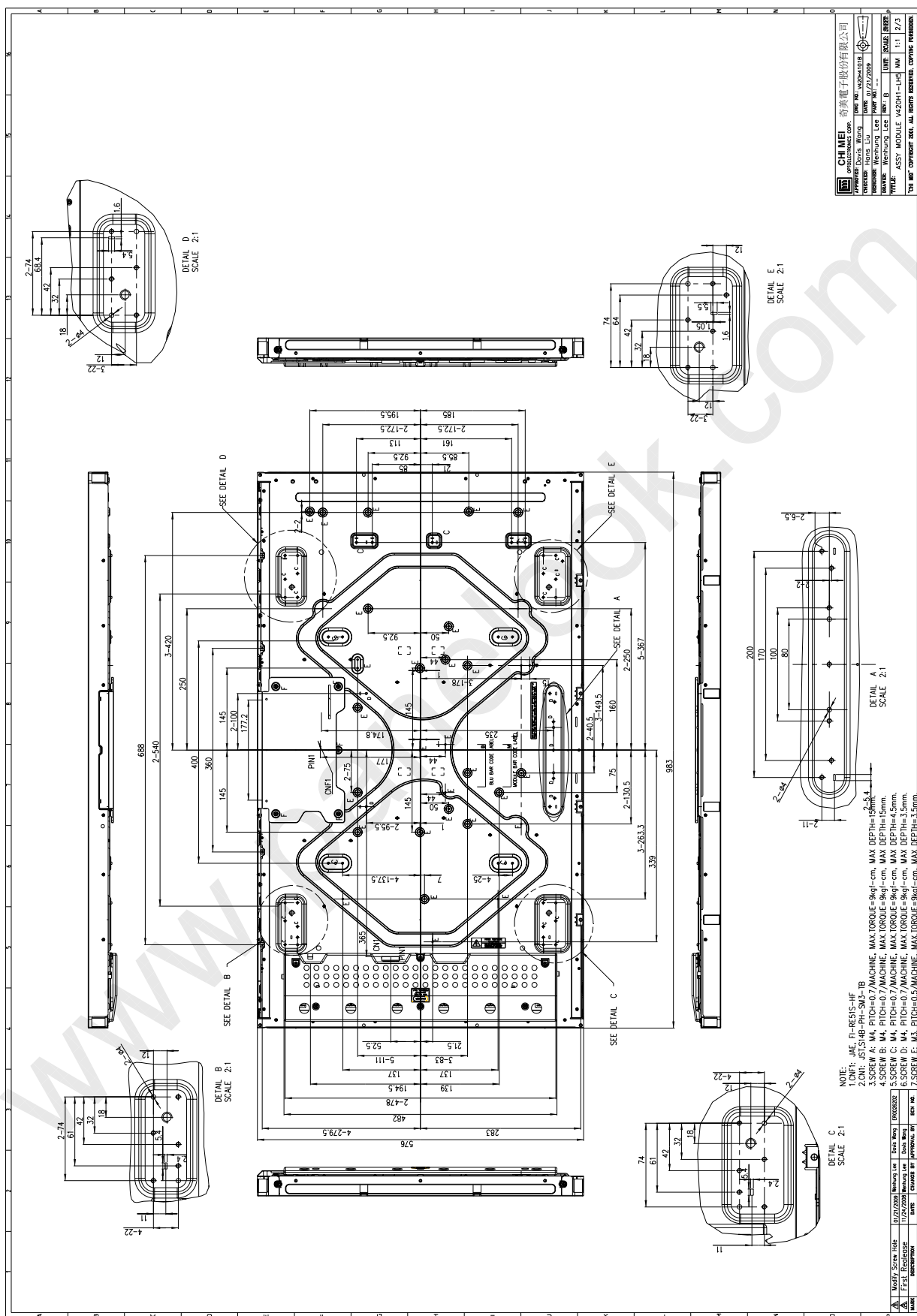
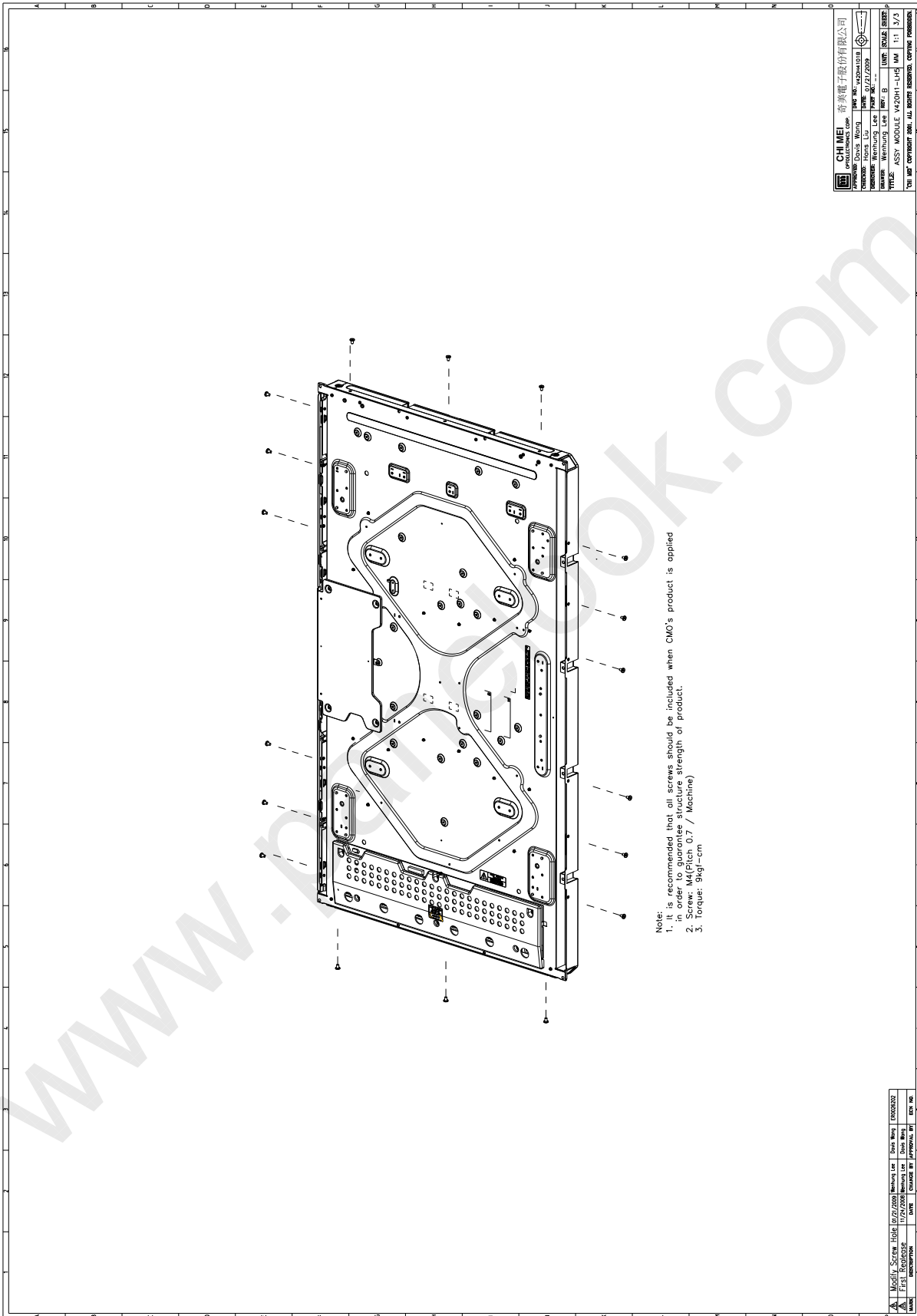

Figure.10-2 packing method



CHI MEI	奇美电子股份有限公司
optoelectronics corp.	
DAVID WANG	王大为
CHENG CHANG	程彰
WANG WENHONG	王文红
WANG WENHONG	王文红
DATE	06/22/2009
DRW	王大为
CHK	程彰
APP	王大为
SCALE	1:1
PAGE	1/1
DESCRIPTION	ASSY MODULE V420H1-LH5
DATE	06/22/2009
DRW	王大为
CHK	程彰
APP	王大为
SCALE	1:1
PAGE	1/1
DESCRIPTION	ASSY MODULE V420H1-LH5

- NOTE:
- 1.ONF1: M&E, FI-RE51S-HF
 - 2.ON1: S1S16-PH-SM-S-B
 - 3.ON1: M&A, PITCH=0.7/MACHINE, MAX.TORQUE=8kgf-cm, MAX.DEPH=15mm
 - 4.SCREW A: M&A, PITCH=0.7/MACHINE, MAX.TORQUE=8kgf-cm, MAX.DEPH=15mm
 - 5.SCREW B: M&A, PITCH=0.7/MACHINE, MAX.TORQUE=8kgf-cm, MAX.DEPH=4.5mm
 - 6.SCREW C: M&A, PITCH=0.7/MACHINE, MAX.TORQUE=8kgf-cm, MAX.DEPH=3.5mm
 - 7.SCREW E: M&A, PITCH=0.5/MACHINE, MAX.TORQUE=8kgf-cm, MAX.DEPH=3.5mm
- | | | | |
|--------------------|------------|---------------|----------|
| Modifi. Screw Hole | 01/22/2009 | Wang Wen Hong | 10020202 |
| PREP | 01/22/2009 | Wang Wen Hong | 10020202 |
| DATE | 06/22/2009 | Wang Wen Hong | 10020202 |
| DRW | 06/22/2009 | Wang Wen Hong | 10020202 |
| CHK | 06/22/2009 | Cheng Chang | 10020202 |
| APP | 06/22/2009 | Wang Wen Hong | 10020202 |



Appendix – TWO Wire BUS INTRODUCTION

A.1 PIN ASSIGNMENT

51pins LVDS connector

Pin8: SCL

Pin9: SDA

A.2 I2C BUS APPLICATION NOTE

I2C bus: (The I2C bus must for MEMC only or prevent the I2C bus voltage drop down in initial state)

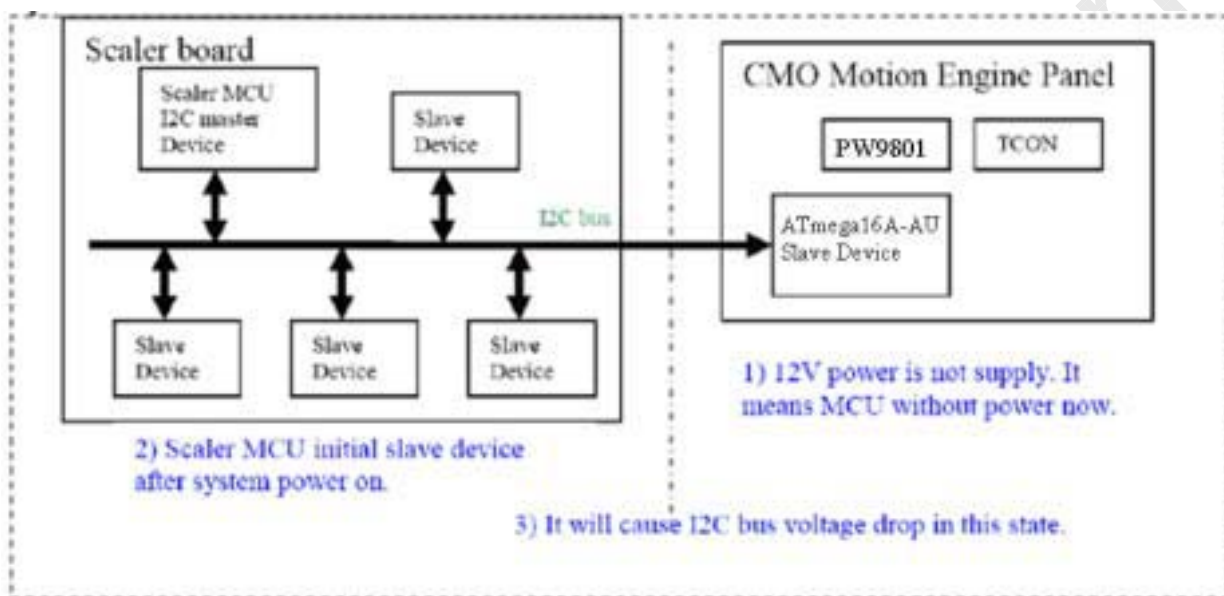

A.3 TWO WIRE BUS DEVICE ADDRESS

Two wire device address: default is 0x40, 1 byte

Two wire command: the range is 0x00 to 0xFF, 1 byte, see the two wire command table.

Two wire bus format:

Device Address : 0x40 default								Command							
D7	D6	D5	D4	D3	D2	D1	D0	D7	D6	D5	D4	D3	D2	D1	D0
0	1	0	0	0	0	0	W/R	L	x	x	x	x	x	x	x

W/R	write : 0; Read : 1
L	1 : 1Byte Data Length; 0: 4Byte Data Length
S	TWI-Bus Start condition from master
Sr	TWI-Bus Start condition from master
A	TWI-Bus Acknowledge bit from master
VA	TWI-Bus Not Acknowledge bit from slave
P	TWI-Bus Stop condition from master
Data	TWI Bus Data from master
Data	TWI Bus Data from slave

A.4 TWO WAY TO CONTROL THE TWO WIRE BUS

There are two options to control the two wires bus command.

Two wire bus 6 bytes format

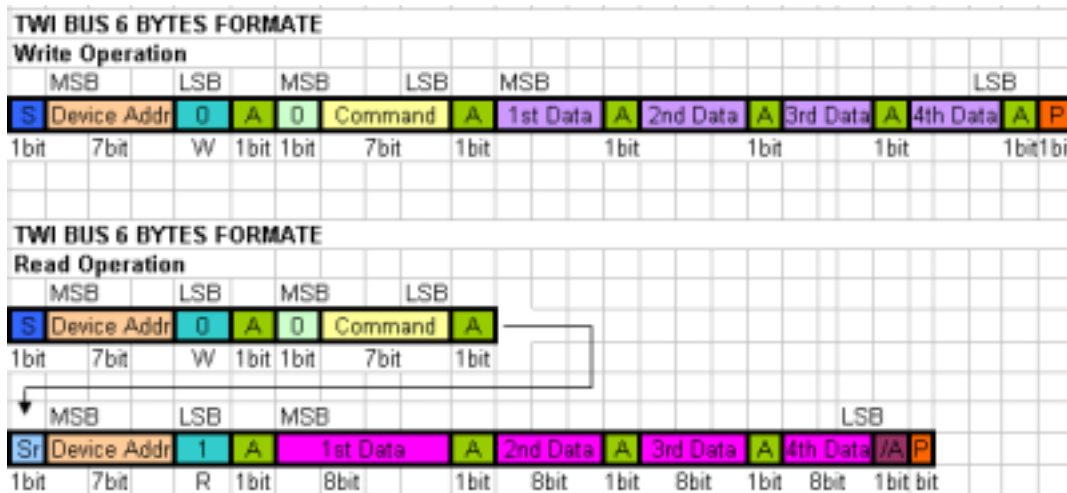

Two wire bus 3 bytes format

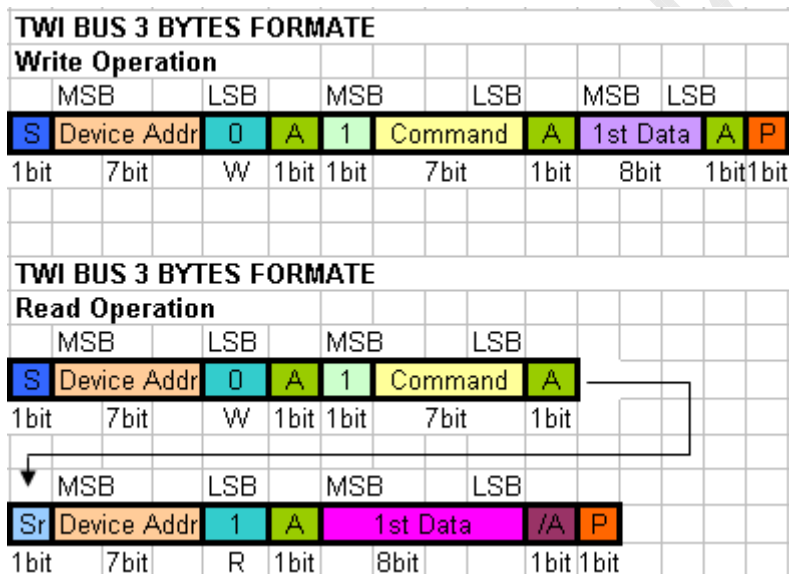

Note:

A transmission basically consists of a START condition, a SLA+R/W, one or more data packets and a STOP condition. An empty message, consisting of a START followed by a STOP condition, is illegal. Note that the wired-ANDing of the SCL line can be used to implement handshaking between the master and the slave. The slave can extend the SCL low period by pulling the SCL line low. This is useful if the clock speed set up by the master is too fast for the slave, or the slave needs extra time for processing between the data transmissions. The slave extending the SCL low period will not affect the SCL high period, which is determined by the master. As a consequence, the slave can reduce the TWI data transfer speed by prolonging the SCL duty cycle.

A.5 TWO WIRE BUS COMMAND TABLE

There is two wire bus command table.

Command Name		Access Mode	Description
All OSD Protection	0x00	R/W	OSDx Enable Flag Control
OSD1_Start_Protection	0x01	R/W	OSD1 Protection Start Position
OSD2_Start_Protection	0x02	R/W	OSD2 Protection Start Position
OSD3_Start_Protection	0x03	R/W	OSD3 Protection Start Position
OSD4_Start_Protection	0x04	R/W	OSD4 Protection Start Position
OSD1_End_Protection	0x05	R/W	OSD1 Protection End Position
OSD2_End_Protection	0x06	R/W	OSD2 Protection End Position
OSD3_End_Protection	0x07	R/W	OSD3 Protection End Position
OSD4_End_Protection	0x08	R/W	OSD4 Protection End Position
Demo Window	0x09	R/W	ME Performance Demo
MEMC Level	0x0A	R/W	ME Performance
GV Mode	0x0B	R/W	ME Operation
Blanking	0x0C	R/W	Blinking the screen

(x1, y1)

OSD protection is rectangle. Please locate the position as below,

(x1-Left, y1-Top) (x2-Right, y2-Bottom)

Motion engine is not active in this blue area.

(x2, y2)

Enable All OSD Protection

AllOSD Protection : 0x00											
4 Bytes Data Length											
1st BYTE DATA	D31	D30	D29	D28	D27	D26	D25	D24	D31~D28	Unused	
	Unused				OSDx				D27	OSD4 flag 1 : On ; 0 : Off	
2nd BYTE DATA	D23	D22	D21	D20	D19	D18	D17	D16	D26	OSD3 flag 1 : On ; 0 : Off	
	Unused								D25	OSD2 flag 1 : On ; 0 : Off	
3rd BYTE DATA	D15	D14	D13	D12	D11	D10	D9	D8	D24	OSD1 flag 1 : On ; 0 : Off	
	Unused								D23~D0	Unused	
4th BYTE DATA	D7	D6	D5	D4	D3	D2	D1	D0			
	Unused										
AllOSD Protection : 0x80											
1 Byte Data Length											
1st BYTE DATA	D7	D6	D5	D4	D3	D2	D1	D0	D7~D4	Unused	
	Unused				OSDx				D3	OSD4 flag 1 : On ; 0 : Off	
									D2	OSD3 flag 1 : On ; 0 : Off	
									D1	OSD2 flag 1 : On ; 0 : Off	
									D0	OSD1 flag 1 : On ; 0 : Off	

OSD # 1~4 Start Protection

OSD1_Start Protection : 0x01											
OSD2_Start Protection : 0x02											
OSD3_Start Protection : 0x03											
OSD4_Start Protection : 0x04											
4 Bytes Data Length											
1st BYTE DATA	D31	D30	D29	D28	D27	D26	D25	D24	D31	OSDx flag 1 : On ; 0 : Off	
	Unused								D30~D27	Unused	
2nd BYTE DATA	D23	D22	D21	D20	D19	D18	D17	D16	D26~D16	OSDx Left position	
	OSD Left								D15~D11	Unused	
3rd BYTE DATA	D15	D14	D13	D12	D11	D10	D9	D8	D10~D0	OSDx Top position	
4th BYTE DATA	D7	D6	D5	D4	D3	D2	D1	D0			
	OSDx Top								Left position Max : 1919 Top position Max : 1079		

OSD # 1~4 End Protection

OSD1_End Protection : 0x05											
OSD2_End Protection : 0x06											
OSD3_End Protection : 0x07											
OSD4_End Protection : 0x08											
4 Bytes Data Length											
1st BYTE DATA	D31	D30	D29	D28	D27	D26	D25	D24	D31~D27	Unused	
	Unused								D26~D16	OSDx Right position	
2nd BYTE DATA	D23	D22	D21	D20	D19	D18	D17	D16	D15~D11	Unused	
	OSD Right								D10~D0	OSDx Bottom position	
3rd BYTE DATA	D15	D14	D13	D12	D11	D10	D9	D8			
	Unused										
4th BYTE DATA	D7	D6	D5	D4	D3	D2	D1	D0	Right position Max : 1919 Bottom position Max : 1079		
	OSD Bottom										

Demo Window

Demo Window : 0x09													
4 Bytes Data Length													
1st BYTE DATA	D31	D30	D29	D28	D27	D26	D25	D24	D31-D25	Unused			
	Unused							D24	Demo Window 1 : On ; 0 : Off				
2nd BYTE DATA	D23	D22	D21	D20	D19	D18	D17	D16	D23-D0	Unused			
	Unused												
3rd BYTE DATA	D15	D14	D13	D12	D11	D10	D9	D8					
	Unused												
4th BYTE DATA	D7	D6	D5	D4	D3	D2	D1	D0					
	Unused												
Demo Window : 0x89													
1 Byte Data Length													
1st BYTE DATA	D7	D6	D5	D4	D3	D2	D1	D0	D7-D1	Unused			
	Unused							D0	Demo Window 1 : On ; 0 : Off				

MEMC Level

ME Level : 0x0A													
4 Bytes Data Length													
1st BYTE DATA	D31	D30	D29	D28	D27	D26	D25	D24	D31-D29	Unused			
	Unused			ME Level				D28-24	ME Level 0-16				
2nd BYTE DATA	D23	D22	D21	D20	D19	D18	D17	D16					
	Unused							0: Strong					
3rd BYTE DATA	D15	D14	D13	D12	D11	D10	D9	D8					
	Unused							1: Normal					
4th BYTE DATA	D7	D6	D5	D4	D3	D2	D1	D0					
	Unused							2: Weak					
	Unused							3: Off					
	Unused							D23-D0	Unused				
ME Level : 0x8A													
1 Byte Data Length													
1st BYTE DATA	D7	D6	D5	D4	D3	D2	D1	D0	D7-D5	Unused			
	Unused			ME Level				D4-D0	ME Level 0-16				
								0: Strong					
								1: Normal					
								2: Weak					
								3: Off					

GV Mode

GV Mode : 0x0B													
4 Bytes Data Length													
1st BYTE DATA	D31	D30	D29	D28	D27	D26	D25	D24	D31-D25	Unused			
	Unused							D24	1: Graphic ; 0: Video				
2nd BYTE DATA	D23	D22	D21	D20	D19	D18	D17	D16	D23-D0	Unused			
	Unused												
3rd BYTE DATA	D15	D14	D13	D12	D11	D10	D9	D8					
	Unused												
4th BYTE DATA	D7	D6	D5	D4	D3	D2	D1	D0					
	Unused												
GV Mode : 0x8B													
1 Byte Data Length													
1st BYTE DATA	D7	D6	D5	D4	D3	D2	D1	D0	D7-D1	Unused			
	Unused							D0	1: Graphic ; 0: Video				

Blanking (Enable/Disable)

Blanking : 0x0C											
4 Bytes Data Length											
1st BYTE DATA	D31	D30	D29	D28	D27	D26	D25	D24	D31~D26	Unused	
	Unused							D24	Blanking; 1 : On ; 0 : Off		
2nd BYTE DATA	D23	D22	D21	D20	D19	D18	D17	D16	D23~D0	Unused	
	Unused							When the input signal is unstable, the screen should be blanked.			
3rd BYTE DATA	D15	D14	D13	D12	D11	D10	D9				D8
	Unused										
4th BYTE DATA	D7	D6	D5	D4	D3	D2	D1	D0			
	Unused										
Blanking : 0x8C											
1 Byte Data Length											
1st BYTE DATA	D7	D6	D5	D4	D3	D2	D1	D0	D7~D1	Unused	
	Unused							D0	Blanking; 1 : On ; 0 : Off		

A.6 TWO WIRE BUS REQUIREMENT

Symbol	Parameter	Condition	Min	Max	Units
V_L	Input Low-voltage		0	0.7	V
V_H	Input High-voltage		2.7	3.3	V
$V_{hyp}^{(1)}$	Hysteresis of Schmitt Trigger Inputs		0.16	–	V
$V_{OL}^{(1)}$	Output Low-voltage	3 mA sink current	0	0.4	V
$t_r^{(1)}$	Rise Time for both SDA and SCL		$20 + 0.1C_b^{(3)(2)}$	900	ns
$t_{of}^{(1)}$	Output Fall Time from V_{IHmin} to V_{ILmax}	$10 \text{ pF} < C_b < 400 \text{ pF}^{(1)}$	$20 + 0.1C_b^{(3)(2)}$	250	ns
$t_{sp}^{(1)}$	Spikes Suppressed by Input Filter		0	$50^{(2)}$	ns
I_i	Input Current each I/O Pin	$0.1V_{CC} < V_i < 0.9V_{CC}$	-10	10	μA
$C_i^{(1)}$	Capacitance for each I/O Pin		–	10	pF
f_{SCL}	SCL Clock Frequency	$f_{CK}^{(4)} > \max(16f_{SCL}, 250\text{kHz})^{(5)}$	0	400	KHz
R_p	Value of Pull-up resistor	$f_{SCL} \leq 100 \text{ kHz}$	3000	$\frac{1000\text{ns}}{C_b}$	Ω
		$f_{SCL} > 100 \text{ kHz}$	3000	$\frac{900\text{ns}}{C_b}$	Ω
$t_{HD,STA}$	Hold Time (repeated) START Condition	$f_{SCL} \leq 100 \text{ kHz}$	4.0	–	μs
		$f_{SCL} > 100 \text{ kHz}$	0.6	–	μs
t_{LOW}	Low Period of the SCL Clock	$f_{SCL} \leq 100 \text{ kHz}^{(6)}$	4.7	–	μs
		$f_{SCL} > 100 \text{ kHz}^{(7)}$	1.3	–	μs
t_{HIGH}	High period of the SCL clock	$f_{SCL} \leq 100 \text{ kHz}$	4.0	–	μs
		$f_{SCL} > 100 \text{ kHz}$	0.6	–	μs
$t_{SU,STA}$	Set-up time for a repeated START condition	$f_{SCL} \leq 100 \text{ kHz}$	4.7	–	μs
		$f_{SCL} > 100 \text{ kHz}$	0.6	–	μs
$t_{HD,DAT}$	Data hold time	$f_{SCL} \leq 100 \text{ kHz}$	0	3.45	μs
		$f_{SCL} > 100 \text{ kHz}$	0	0.0	μs
$t_{SU,DAT}$	Data setup time	$f_{SCL} \leq 100 \text{ kHz}$	250	–	ns
		$f_{SCL} > 100 \text{ kHz}$	100	–	ns
$t_{SU,STO}$	Setup time for STOP condition	$f_{SCL} \leq 100 \text{ kHz}$	4.0	–	μs
		$f_{SCL} > 100 \text{ kHz}$	0.6	–	μs
t_{BFC}	Bus free time between a STOP and START condition	$f_{SCL} \leq 100 \text{ kHz}$	4.7	–	μs
		$f_{SCL} > 100 \text{ kHz}$	1.3	–	μs

A.7 THE TWO WIRE BUS SEQUENCE

Two Wire command can be initialized during 20ms to 60ms.

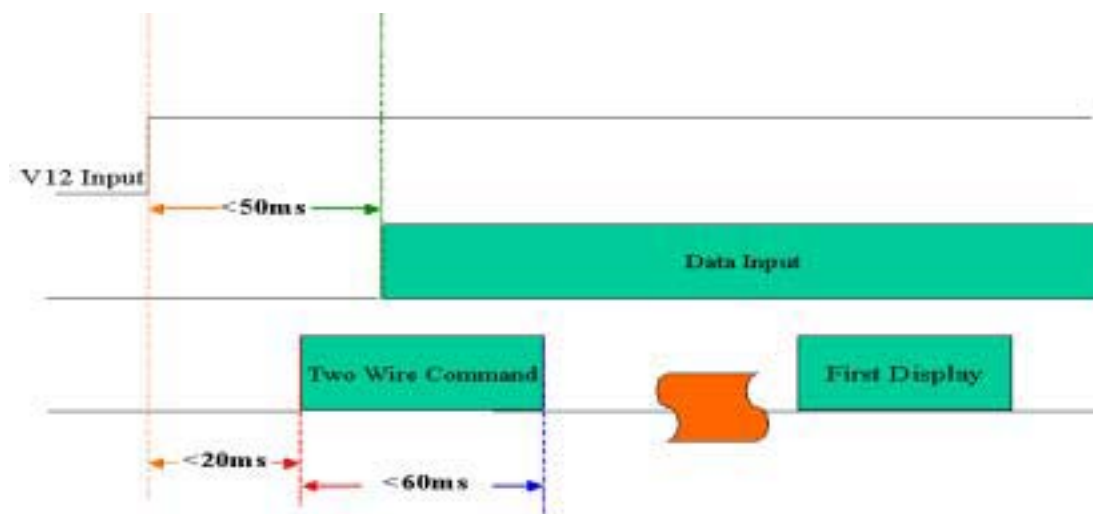

Example:

The previous state is strong mode, and the power is reset. The two wire command (strong mode command) must be initialized during 20ms to 60ms.