



## CONTENTS

<b>1. GENERAL DESCRIPTION</b> .....	4
<b>1.1 OVERVIEW</b> .....	4
<b>1.2 FEATURES</b> .....	4
<b>1.3 MECHANICAL SPECIFICATIONS</b> .....	4
<b>2. ABSOLUTE MAXIMUM RATINGS</b> .....	5
<b>2.1 ABSOLUTE RATINGS OF ENVIRONMENT</b> .....	5
<b>2.2 PACKAGE STORAGE</b> .....	6
<b>2.3 ELECTRICAL ABSOLUTE RATINGS</b> .....	6
<b>3. ELECTRICAL CHARACTERISTICS</b> .....	7
<b>3.1 TFT LCD MODULE</b> .....	7
<b>4. BLOCK DIAGRAM OF INTERFACE</b> .....	10
<b>4.1 TFT LCD MODULE</b> .....	10
<b>5. INTERFACE PIN CONNECTION</b> .....	11
<b>5.1 TFT LCD MODULE</b> .....	11
<b>5.2 LVDS INTERFACE</b> .....	14
<b>5.3 COLOR DATA INPUT ASSIGNMENT</b> .....	11
<b>5.4 FLICKER(Vcom) ADJUSTMENT</b> .....	14
<b>6. INTERFACE TIMING</b> .....	17
<b>6.1 INPUT SIGNAL TIMING SPECIFICATIONS</b> .....	17
<b>6.2 POWER ON/OFF SEQUENCE</b> .....	20
<b>7. OPTICAL CHARACTERISTICS</b> .....	21
<b>7.1 TEST CONDITIONS</b> .....	21
<b>7.2 OPTICAL SPECIFICATIONS</b> .....	21
<b>8. DEFINITION OF LABELS</b> .....	24
<b>8.1 CMO MODULE LABEL</b> .....	24
<b>9. PACKAGING</b> .....	25
<b>9.1 PACKING SPECIFICATIONS</b> .....	25
<b>9.2 PACKING METHOD</b> .....	26
<b>10. PRECAUTIONS</b> .....	27
<b>10.1 ASSEMBLY AND HANDLING PRECAUTIONS</b> .....	27
<b>10.2 SAFETY PRECAUTIONS</b> .....	27
<b>11. MECHANICAL CHARACTERISTICS</b> .....	28



## REVISION HISTORY

Version	Date	Page(New)	Section	Description
Ver. 2.0	Jul 08, 2010	All	All	The specification was first issued.

## 1. GENERAL DESCRIPTION

### 1.1 OVERVIEW

V420H2-PE1 is a 42" TFT Liquid Crystal Display product with driver ICs and 4ch-LVDS interface. This product supports 1920 x 1080 Full HDTV format and can display 1.07G (8-bit + Hi-FRC) colors.

### 1.2 FEATURES

CHARACTERISTICS ITEMS	SPECIFICATIONS
Screen Diagonal [in]	42.02
Pixels [lines]	1920 × 1080
Active Area [mm]	930.24(H) × 523.26(V) (42" diagonal)
Sub-Pixel Pitch [mm]	0.1615(H) × 0.4845(V)
Pixel Arrangement	RGB vertical stripe
Weight [g]	TYP. 2155 g
Physical Size [mm]	955.04(W) × 545.66(H) × 2.00(D) Typ.
Display Mode	Transmissive mode / Normally black
Contrast Ratio	6000:1 Typ. (Typical value measure at CMO's module)
Glass thickness (Array / CF) [mm]	0.7 / 0.7
Viewing Angle (CR>20)	+88/-88(H), +88/-88(V) Typ. (CR ≥ 20) (Typical value measure at CMO's module)
Color Chromaticity	R=(0.650, 0.327) G=(0.297, 0.594) B=(0.134, 0.106) W=(0.310, 0.357) (Light source is the standard light source "C" which is defined by CIE and driving voltages are based on suitable gamma voltages.)
Cell Transparency [%]	4.8%
Polarizer Surface Treatment	Anti-Glare coating (Haze 11%), Hard coating (3H)

### 1.3 MECHANICAL SPECIFICATIONS

Item	Min.	Typ.	Max.	Unit	Note
Weight	2105	2155	2205	g	-
I/F connector mounting position	The mounting inclination of the connector makes the screen center within ± 0.5mm as the horizontal.				(2)

Note (1) Please refer to the attached drawings for more information of front and back outline dimensions.

Note (2) Connector mounting position

## 2. ABSOLUTE MAXIMUM RATINGS

### 2.1 ABSOLUTE RATINGS OF ENVIRONMENT

Item	Symbol	Value		Unit	Note
		Min.	Max.		
Storage Temperature	T <sub>ST</sub>	-20	+60	°C	(1)
Operating Ambient Temperature	T <sub>OP</sub>	0	+50	°C	(1), (2)
Vibration (Non-Operating)	V <sub>NOF</sub>	-	1.0	G	(3), (4)

Note (1) Temperature and relative humidity range is shown in the figure below.

(a) 90 %RH Max. ( $T_a \leq 40$  °C).

(b) Wet-bulb temperature should be 39 °C Max. ( $T_a > 40$  °C).

(c) No condensation.

Note (2) The maximum operating temperature is based on the test condition that the surface temperature of display area is less than or equal to 65 °C with LCD module alone in a temperature controlled chamber. Thermal management should be considered in final product design to prevent the surface temperature of display area from being over 65 °C. The range of operating temperature may degrade in case of improper thermal management in final product design.

Note (3) 10 ~ 200 Hz, 10 min, 1 time each X, Y, Z.

Note (4) At testing Vibration and Shock, the fixture in holding the module has to be hard and rigid enough so that the module would not be twisted or bent by the fixture.

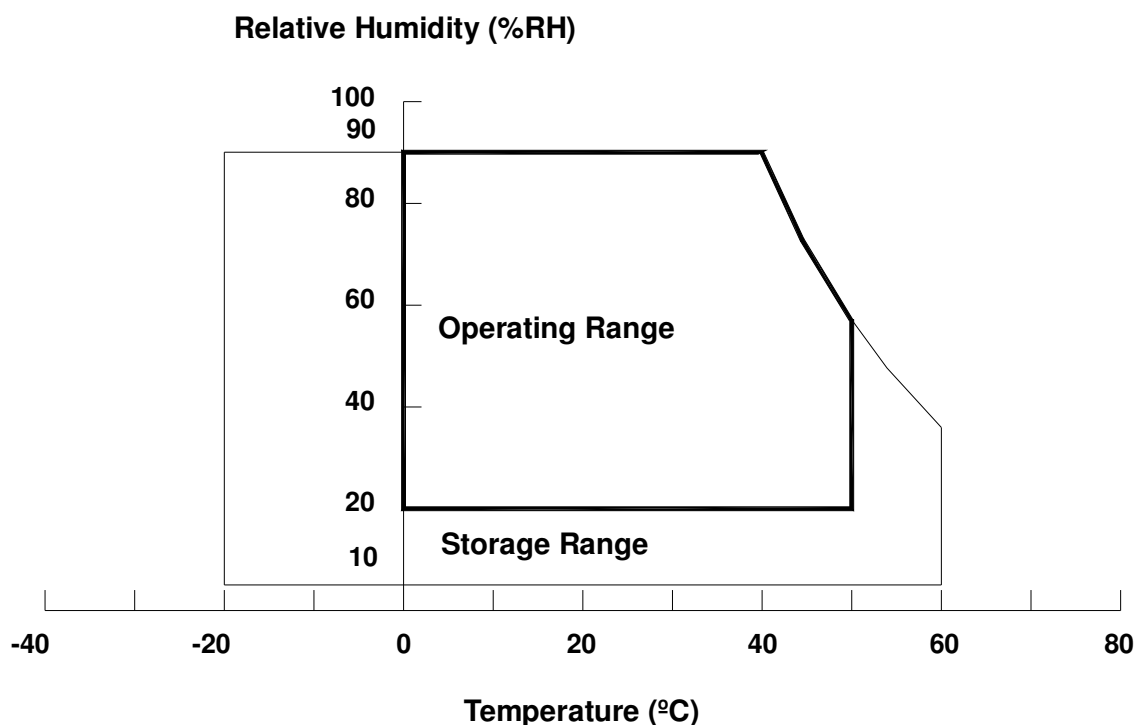

## 2.2 PACKAGE STORAGE

When storing modules as spares for a long time, the following precaution is necessary.

- (a) Do not leave the module in high temperature, and high humidity for a long time. It is highly recommended to store the module with temperature from 0 to 35°C at normal humidity without condensation.
- (b) The module shall be stored in dark place. Do not store the TFT-LCD module in direct sunlight or fluorescent light.

## 2.3 ELECTRICAL ABSOLUTE RATINGS

### 2.3.1 TFT LCD MODULE

Item	Symbol	Value		Unit	Note
		Min.	Max.		
Power Supply Voltage	V <sub>CC</sub>	-0.3	13.5	V	
Input Signal Voltage	V <sub>IN</sub>	-0.3	3.6	V	

### 2.3.2 BACKLIGHT CONVERTER UNIT

Item	Symbol	Value		Unit	Note
		Min.	Max.		
Lamp Voltage	V <sub>W</sub>	—	3000	VRMS	
Power Supply Voltage	V <sub>BL</sub>	0	30	V	(1)
Control Signal Level	—	-0.3	7	V	(1), (3)

Note (1) Permanent damage to the device may occur if maximum values are exceeded. Functional operation should be restricted to the conditions described under normal operating conditions.

Note (2) No moisture condensation or freezing.

Note (3) The control signals include On/Off Control and Internal PWM Control.

### 3. ELECTRICAL CHARACTERISTICS

#### 3.1 TFT LCD MODULE

Ta = 25 ± 2 °C

Parameter		Symbol	Value			Unit	Note
			Min.	Typ.	Max.		
Power Supply Voltage		V <sub>CC</sub>	10.8	12	13.2	V	(1)
Rush Current		I <sub>RUSH</sub>	-	-	4.17	A	(2)
Power Supply Current	White Pattern	-	-	1.27	1.65	A	(3)
	Horizontal Stripe	-	-	1.32	1.72	A	
	Black Pattern	-	-	0.58	-	A	
LVDS interface	Differential Input High Threshold Voltage	V <sub>LVTH</sub>	+100	-	-	mV	(4)
	Differential Input Low Threshold Voltage	V <sub>LVTL</sub>	-	-	-100	mV	
	Common Input Voltage	V <sub>CM</sub>	1.0	1.2	1.4	V	
	Differential input voltage	V <sub>ID</sub>	200	-	600	mV	
	Terminating Resistor	R <sub>T</sub>	-	100	-	ohm	
CMOS interface	Input High Threshold Voltage	V <sub>IH</sub>	2.7	-	3.3	V	
	Input Low Threshold Voltage	V <sub>IL</sub>	0	-	0.7	V	

Note (1) The module should be always operated within above ranges.

Note (2) Measurement Conditions:

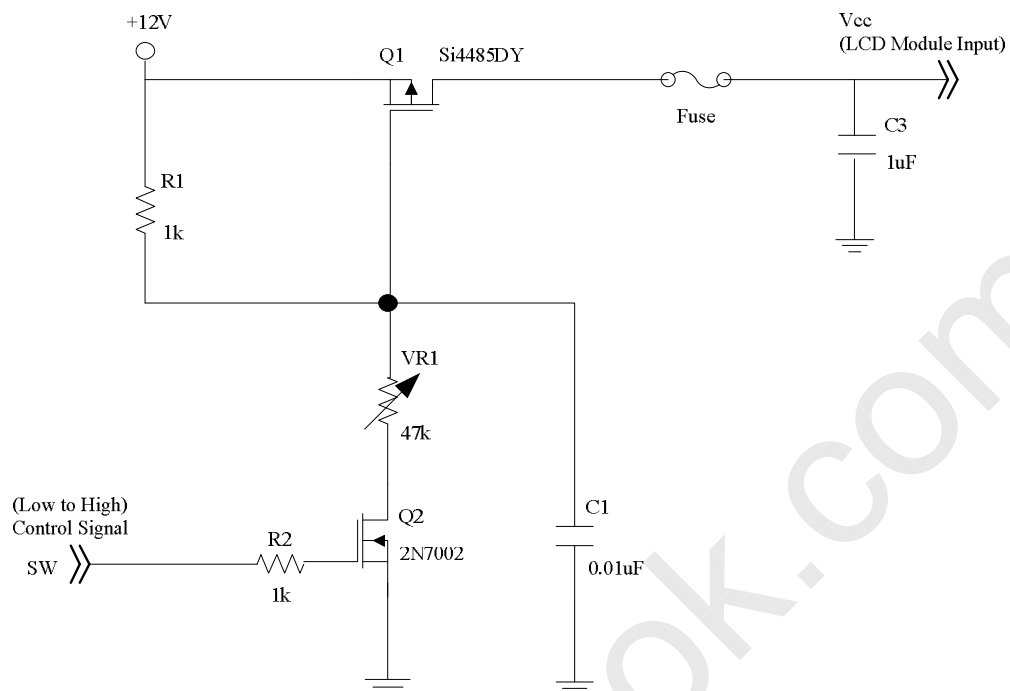

**Vcc rising time is 470us**

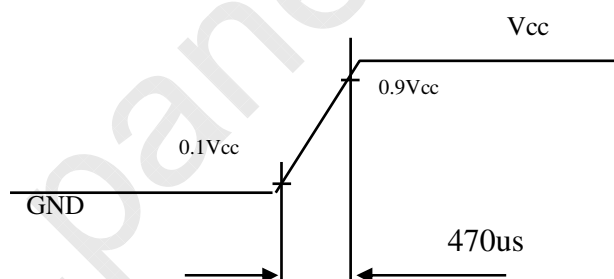



Note (3) The specified power supply current is under the conditions at  $V_{CC} = 12V$ ,  $T_a = 25 \pm 2 \text{ }^\circ\text{C}$ ,  $f_v = 120 \text{ Hz}$ , whereas a power dissipation check pattern below is displayed.

a. White Pattern

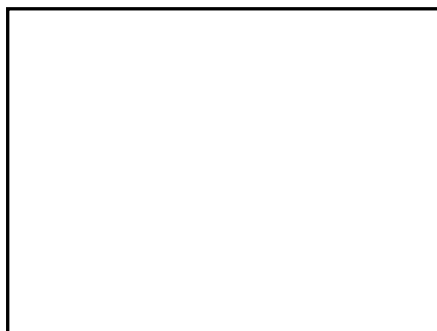

Active Area

b. Black Pattern



Active Area

c. Horizontal Pattern

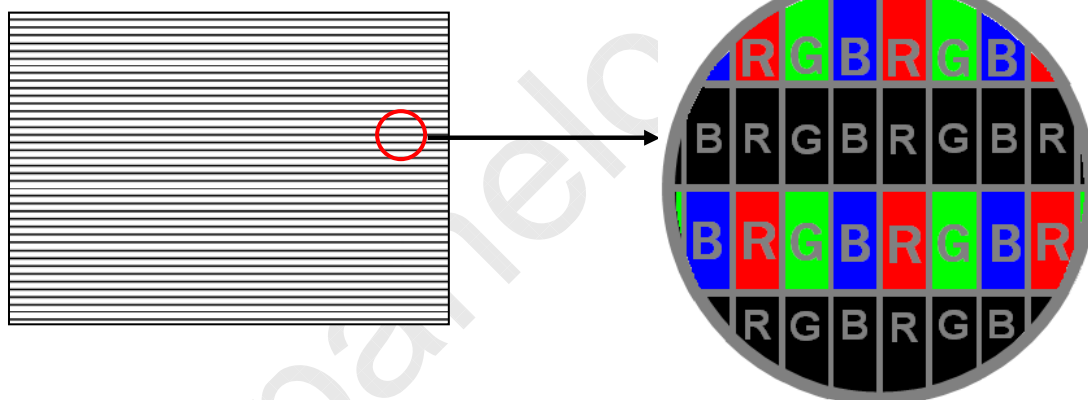

Note (4) The LVDS input characteristics are as follows:

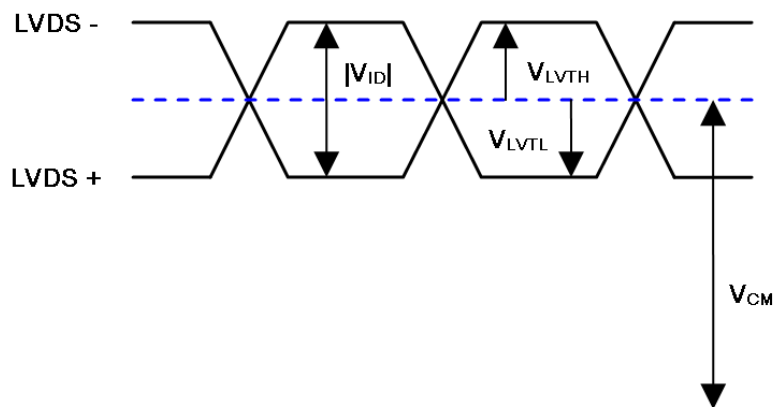

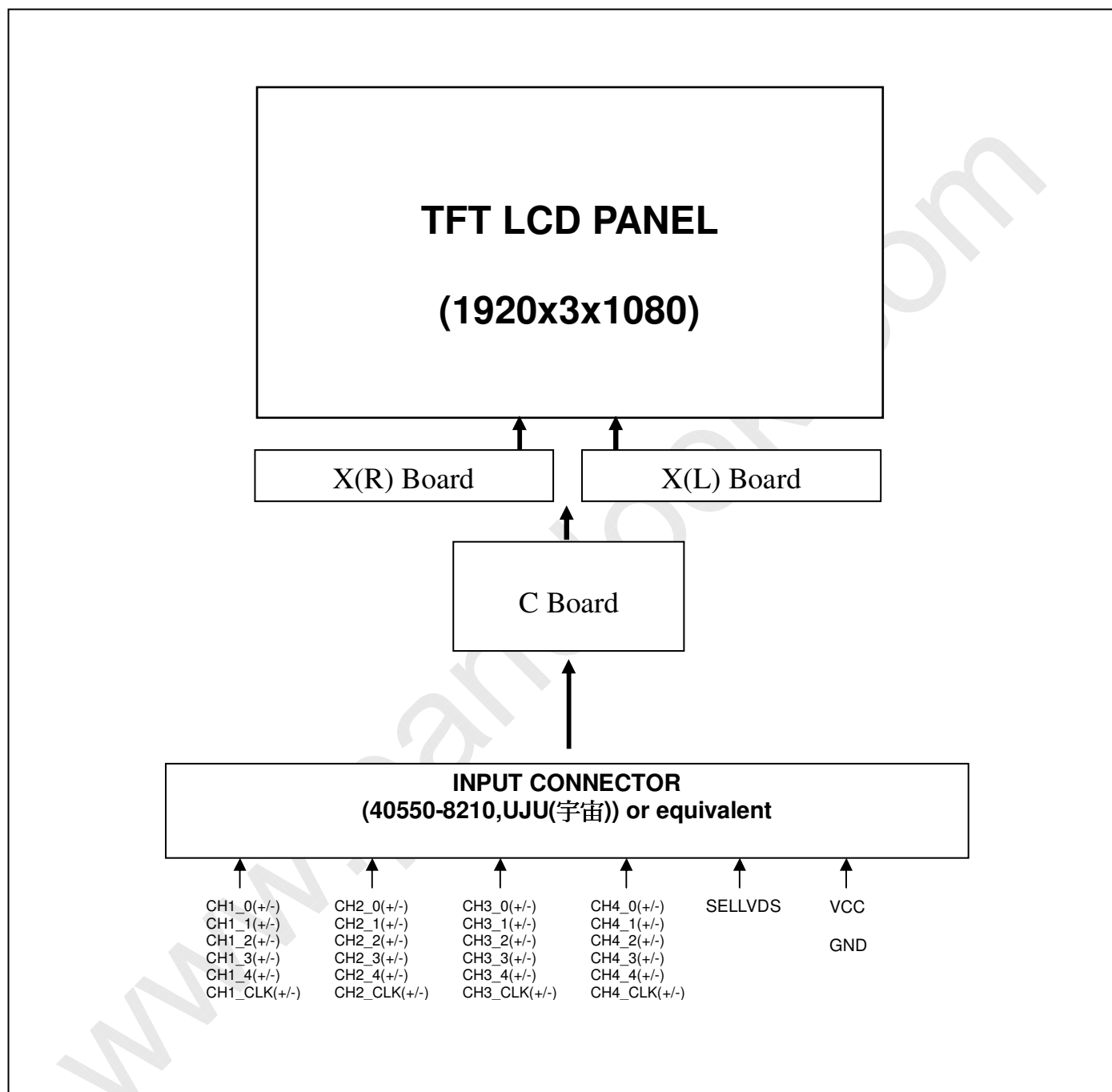
**4. BLOCK DIAGRAM OF INTERFACE**
**4.1 TFT LCD MODULE**

## 5. INTERFACE PIN CONNECTION

### 5.1 TFT LCD MODULE

#### CN1(XL) Connector Pin Assignment

Pin	Symbol	Description	Pin	Symbol	Description
1	GND	Ground	41	N.C.	No connection
2	MLB6N	B-Path mini-LVDS data	42	STV	Scan driver start pulse
3	MLB6P	B-Path mini-LVDS data	43	TP1	Mini-LVDS data latch
4	MLB5N	B-Path mini-LVDS data	44	EIO3	Data driver start pulse
5	MLB5P	B-Path mini-LVDS data	45	EIO4	Data driver start pulse
6	MLB4N	B-Path mini-LVDS data	46	VDASEL	Switch for half-VDDA
7	MLB4P	B-Path mini-LVDS data	47	GND	Ground
8	GND	Ground	48	GM18	Gamma power supply
9	MLBCKN	Data driver clock	49	GM17	Gamma power supply
10	MLBCKP	Data driver clock	50	GM16	Gamma power supply
11	GND	Ground	51	GM15	Gamma power supply
12	MLB2N	B-Path mini-LVDS data	52	GM14	Gamma power supply
13	MLB2P	B-Path mini-LVDS data	53	GM13	Gamma power supply
14	MLB1N	B-Path mini-LVDS data	54	GM12	Gamma power supply
15	MLB1P	B-Path mini-LVDS data	55	GM10	Gamma power supply
16	MLB0N	B-Path mini-LVDS data	56	GM9	Gamma power supply
17	MLB0P	B-Path mini-LVDS data	57	GM7	Gamma power supply
18	GND	Ground	58	GM6	Gamma power supply
19	MLA6N	A-Path mini-LVDS data	59	GM5	Gamma power supply
20	MLA6P	A-Path mini-LVDS data	60	GM4	Gamma power supply
21	MLA5N	A-Path mini-LVDS data	61	GM3	Gamma power supply
22	MLA5P	A-Path mini-LVDS data	62	GM2	Gamma power supply
23	MLA4N	A-Path mini-LVDS data	63	GM1	Gamma power supply
24	MLA4P	A-Path mini-LVDS data	64	GND	Ground
25	GND	Ground	65	VDDAH	Data driver power supply
26	MLACKN	Data driver clock	66	VDDAL	Data driver power supply
27	MLACKP	Data driver clock	67	GND	Ground
28	GND	Ground	68	VCM	Vcom power supply
29	MLA2N	A-Path mini-LVDS data	69	VCM	Vcom power supply
30	MLA2P	A-Path mini-LVDS data	70	GND	Ground
31	MLA1N	A-Path mini-LVDS data	71	VDDA	Data driver power supply
32	MLA1P	A-Path mini-LVDS data	72	VDDA	Data driver power supply
33	MLA0N	A-Path mini-LVDS data	73	GND	Ground
34	MLA0P	A-Path mini-LVDS data	74	VDD	Logic power supply
35	GND	Ground	75	VDD	Logic power supply
36	GND	Ground	76	VGL	Scan driver power supply
37	OE1	Scan driver output	77	VGL	Scan driver power supply
38	OE2	Scan driver output	78	VGH	Scan driver power supply
39	CKV	Scan driver clock	79	VGH	Scan driver power supply
40	POL	Polarity inverting input	80	GND	Ground

## CN1(XR) Connector Pin Assignment

Pin	Symbol	Description	Pin	Symbol	Description
1	GND	Ground	41	MLD2P	D-Path mini-LVDS data
2	VGH	Scan driver power supply	42	MLD1N	D-Path mini-LVDS data
3	VGH	Scan driver power supply	43	MLD1P	D-Path mini-LVDS data
4	VGL	Scan driver power supply	44	MLD0N	D-Path mini-LVDS data
5	VGL	Scan driver power supply	45	MLD0P	D-Path mini-LVDS data
6	VDD	Logic power supply	46	GND	Ground
7	VDD	Logic power supply	47	MLC6N	C-Path mini-LVDS data
8	GND	Ground	48	MLC6P	C-Path mini-LVDS data
9	VDDA	Data driver power supply	49	MLC5N	C-Path mini-LVDS data
10	VDDA	Data driver power supply	50	MLC5P	C-Path mini-LVDS data
11	GND	Ground	51	MLC4N	C-Path mini-LVDS data
12	VCM	Vcom power supply	52	MLC4P	C-Path mini-LVDS data
13	VCM	Vcom power supply	53	GND	Ground
14	GND	Ground	54	MLCCKN	Data driver clock
15	VDDAL	Data driver power supply	55	MLCCKP	Data driver clock
16	VDDAH	Data driver power supply	56	GND	Ground
17	GND	Ground	57	MLC2N	C-Path mini-LVDS data
18	VSCM	VSCM Power supply	58	MLC2P	C-Path mini-LVDS data
19	VDASEL	Switch for half-VDDA	59	MLC1N	C-Path mini-LVDS data
20	EIO4	Data driver start pulse	60	MLC1P	C-Path mini-LVDS data
21	EIO3	Data driver start pulse	61	MLC0N	C-Path mini-LVDS data
22	TP1	Mini-LVDS data latch	62	MLC0P	C-Path mini-LVDS data
23	STV	Scan driver start pulse	63	GND	Ground
24	N.C.	No connection	64	GM18	Gamma power supply
25	POL	Polarity inverting input	65	GM17	Gamma power supply
26	CKV	Scan driver clock	66	GM16	Gamma power supply
27	OE2	Scan driver output	67	GM15	Gamma power supply
28	OE1	Scan driver output	68	GM14	Gamma power supply
29	GND	Ground	69	GM13	Gamma power supply
30	MLD6N	D-Path mini-LVDS data	70	GM12	Gamma power supply
31	MLD6P	D-Path mini-LVDS data	71	GM10	Gamma power supply
32	MLD5N	D-Path mini-LVDS data	72	GM9	Gamma power supply
33	MLD5P	D-Path mini-LVDS data	73	GM7	Gamma power supply
34	MLD4N	D-Path mini-LVDS data	74	GM6	Gamma power supply
35	MLD4P	D-Path mini-LVDS data	75	GM5	Gamma power supply
36	GND	Ground	76	GM4	Gamma power supply
37	MLDCKN	Data driver clock	77	GM3	Gamma power supply
38	MLDCKP	Data driver clock	78	GM2	Gamma power supply
39	GND	Ground	79	GM1	Gamma power supply
40	MLD2N	D-Path mini-LVDS data	80	GND	Ground

Note (1) CN1 Connector Part No.: B-F,196225-80041,P-TWO(禾昌)

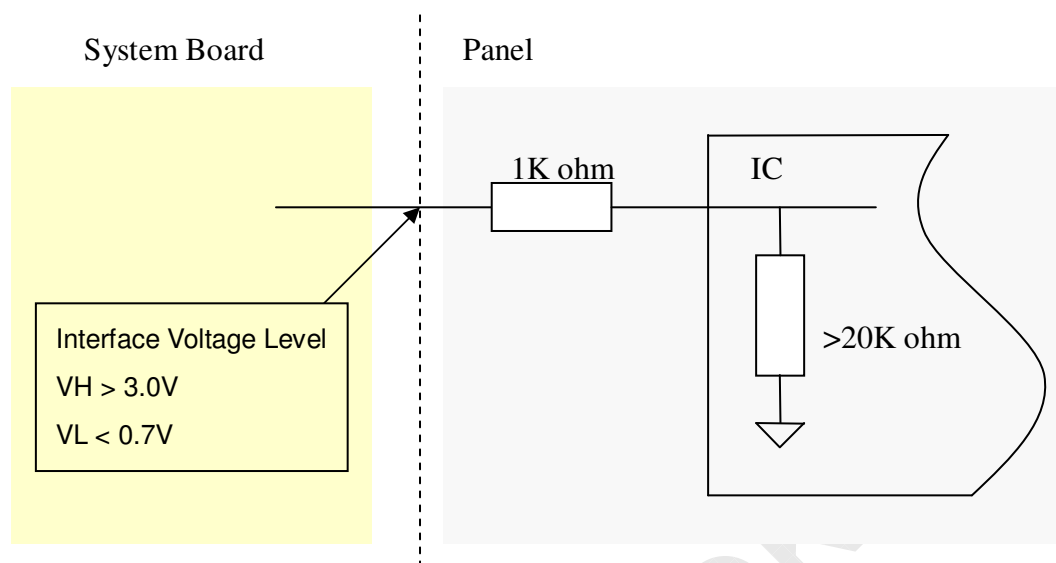

Note (2) LVDS 4-port Data Mapping

Port	Channel of LVDS	Data Stream
1st Port	First Pixel	1, 5, 9, .....1913, 1917
2nd Port	Second Pixel	2, 6, 10, ....1914, 1918
3rd Port	Third Pixel	3, 7, 11, ....1915, 1919
4th Port	Fourth Pixel	4, 8, 12, ....1916, 1920

**5.2 LVDS INTERFACE**

VESA Format : SELLVDS = L or Open

JEIDA Format : SELLVDS = H

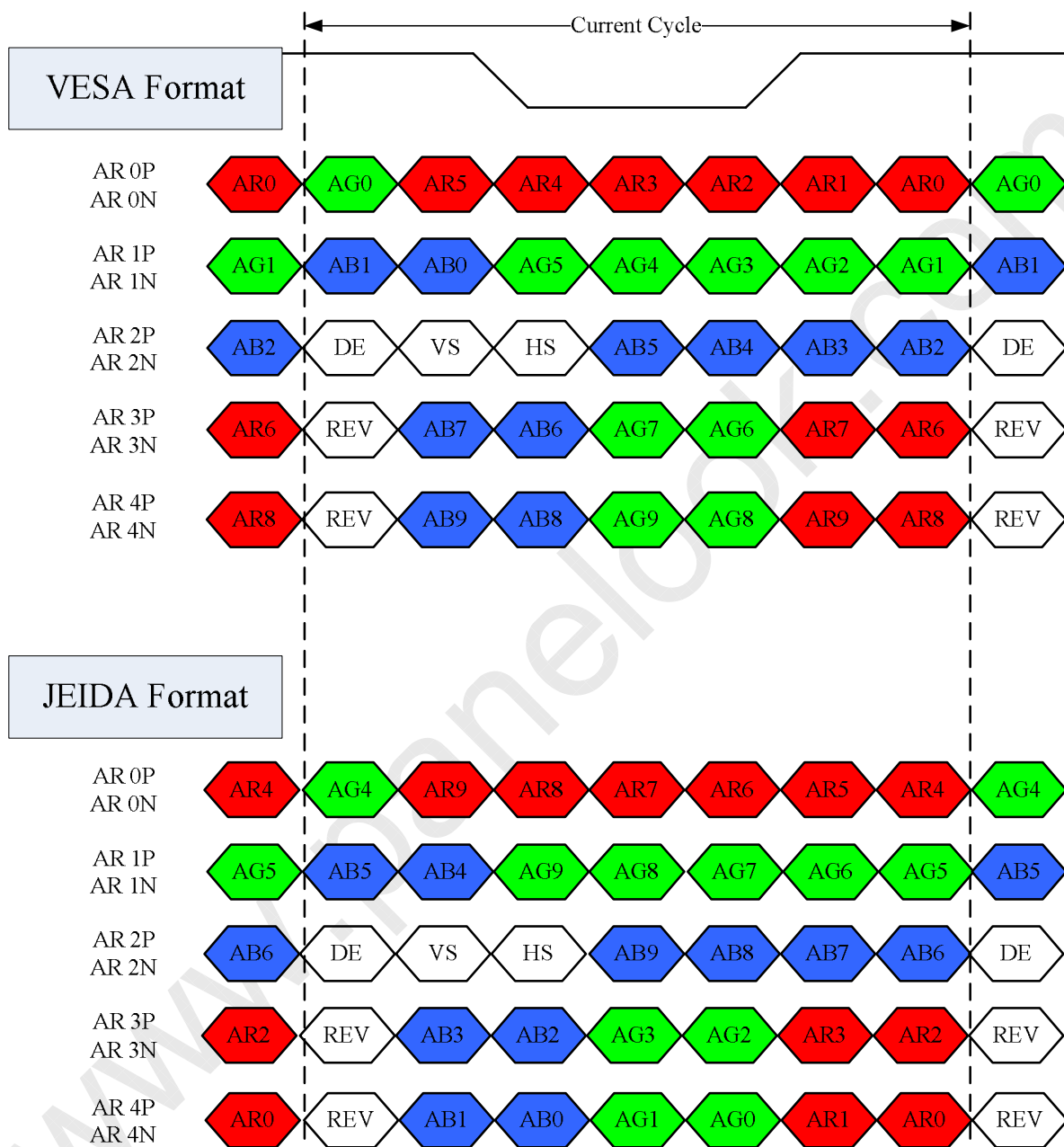

AR0~AR9: First Pixel R Data (9; MSB, 0; LSB)

AG0~AG9: First Pixel G Data (9; MSB, 0; LSB)

AB0~AB9: First Pixel B Data (9; MSB, 0; LSB)

DE : Data enable signal

DCLK : Data clock signal

RSV : Reserved

**5.3 COLOR DATA INPUT ASSIGNMENT**

The brightness of each primary color (red, green and blue) is based on the 10-bit gray scale data input for the color. The higher the binary input, the brighter the color. The table below provides the assignment of the color versus data input.

Color		Data Signal																											
		Red										Green										Blue							
		R	R	R	R	R	R	R	R	R	R	G	G	G	G	G	G	G	G	G	G	B	B	B	B	B	B	B	B
9	8	7	6	5	4	3	2	1	0	9	8	7	6	5	4	3	2	1	0	9	8	7	6	5	4	3	2	1	0
Basic Colors	Black	0	0	0	0	0	0	0	0	0	0	0	0	0	0	0	0	0	0	0	0	0	0	0	0	0	0	0	
	Red	1	1	1	1	1	1	1	1	1	0	0	0	0	0	0	0	0	0	0	0	0	0	0	0	0	0	0	
	Green	0	0	0	0	0	0	0	0	0	1	1	1	1	1	1	1	1	1	1	0	0	0	0	0	0	0	0	
	Blue	0	0	0	0	0	0	0	0	0	0	0	0	0	0	0	0	0	0	0	1	1	1	1	1	1	1	1	
	Cyan	0	0	0	0	0	0	0	0	0	1	1	1	1	1	1	1	1	1	1	1	1	1	1	1	1	1	1	
	Magenta	1	1	1	1	1	1	1	1	1	0	0	0	0	0	0	0	0	0	0	1	1	1	1	1	1	1	1	
	Yellow	1	1	1	1	1	1	1	1	1	1	1	1	1	1	1	1	1	1	1	0	0	0	0	0	0	0	0	
	White	1	1	1	1	1	1	1	1	1	1	1	1	1	1	1	1	1	1	1	1	1	1	1	1	1	1	1	
Gray Scale Of Red	Red (0) / Dark	0	0	0	0	0	0	0	0	0	0	0	0	0	0	0	0	0	0	0	0	0	0	0	0	0	0		
	Red (1)	0	0	0	0	0	0	0	0	1	0	0	0	0	0	0	0	0	0	0	0	0	0	0	0	0	0		
	Red (2)	0	0	0	0	0	0	0	1	0	0	0	0	0	0	0	0	0	0	0	0	0	0	0	0	0	0		
	:	:	:	:	:	:	:	:	:	:	:	:	:	:	:	:	:	:	:	:	:	:	:	:	:	:	:		
	:	:	:	:	:	:	:	:	:	:	:	:	:	:	:	:	:	:	:	:	:	:	:	:	:	:	:		
	Red (1021)	1	1	1	1	1	1	1	0	1	0	0	0	0	0	0	0	0	0	0	0	0	0	0	0	0	0		
	Red (1022)	1	1	1	1	1	1	1	0	0	0	0	0	0	0	0	0	0	0	0	0	0	0	0	0	0	0		
	Red (1023)	1	1	1	1	1	1	1	1	1	0	0	0	0	0	0	0	0	0	0	0	0	0	0	0	0	0		
Gray Scale Of Green	Green(0) / Dark	0	0	0	0	0	0	0	0	0	0	0	0	0	0	0	0	0	0	0	0	0	0	0	0	0	0		
	Green (1)	0	0	0	0	0	0	0	0	0	0	0	0	0	0	0	0	0	0	1	0	0	0	0	0	0	0		
	Green (2)	0	0	0	0	0	0	0	0	0	0	0	0	0	0	0	0	0	1	0	0	0	0	0	0	0	0		
	:	:	:	:	:	:	:	:	:	:	:	:	:	:	:	:	:	:	:	:	:	:	:	:	:	:	:		
	:	:	:	:	:	:	:	:	:	:	:	:	:	:	:	:	:	:	:	:	:	:	:	:	:	:	:		
	Green (1021)	0	0	0	0	0	0	0	0	0	1	1	1	1	1	1	1	1	0	1	0	0	0	0	0	0	0		
	Green (1022)	0	0	0	0	0	0	0	0	0	1	1	1	1	1	1	1	1	0	0	0	0	0	0	0	0	0		
	Green (1023)	0	0	0	0	0	0	0	0	0	1	1	1	1	1	1	1	1	1	0	0	0	0	0	0	0	0		
Gray Scale Of Blue	Blue (0) / Dark	0	0	0	0	0	0	0	0	0	0	0	0	0	0	0	0	0	0	0	0	0	0	0	0	0	0		
	Blue (1)	0	0	0	0	0	0	0	0	0	0	0	0	0	0	0	0	0	0	0	0	0	0	0	0	0	1		
	Blue (2)	0	0	0	0	0	0	0	0	0	0	0	0	0	0	0	0	0	0	0	0	0	0	0	0	1	0		
	:	:	:	:	:	:	:	:	:	:	:	:	:	:	:	:	:	:	:	:	:	:	:	:	:	:	:		
	:	:	:	:	:	:	:	:	:	:	:	:	:	:	:	:	:	:	:	:	:	:	:	:	:	:	:		
	:	:	:	:	:	:	:	:	:	:	:	:	:	:	:	:	:	:	:	:	:	:	:	:	:	:	:		

Blue (1021)	0	0	0	0	0	0	0	0	0	0	0	0	0	0	0	0	0	0	0	0	1	1	1	1	1	1	1	1	1	0	1
Blue (1022)	0	0	0	0	0	0	0	0	0	0	0	0	0	0	0	0	0	0	0	0	1	1	1	1	1	1	1	1	1	1	0
Blue (1023)	0	0	0	0	0	0	0	0	0	0	0	0	0	0	0	0	0	0	0	0	1	1	1	1	1	1	1	1	1	1	1

Note (1) 0: Low Level Voltage, 1: High Level Voltage

## 5.4 FLICKER (Vcom) ADJUSTMENT

(1) Adjustment Pattern:

2n line-inversion pattern was shown as below. If customer need below pattern, please directly contact with Account FAE.

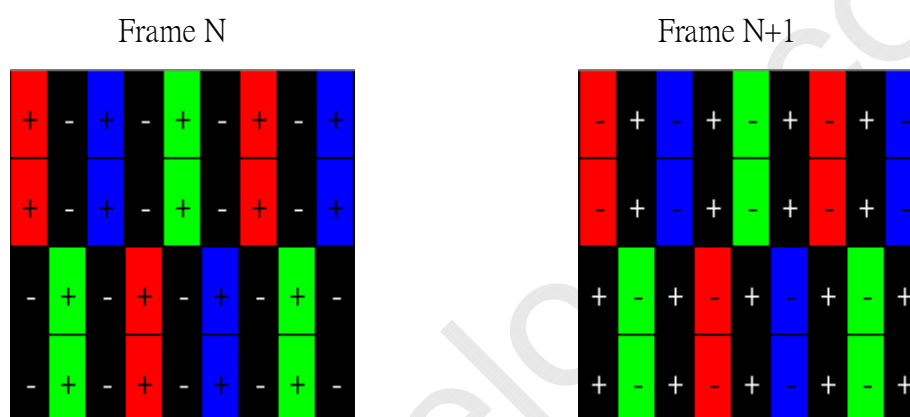

(2) Adjustment method: (Digital V-com)

Programmable memory IC is used for Digital V-com adjustment in this model. CMI provide Auto Vcom tools to adjust Digital V-com. The detail connection and setting instruction, please directly contact with Account FAE or refer CMI Auto V-com adjustment OI. Below items is suggested to be ready before Digital V-com adjustment in customer LCM line.

- USB Sensor Board. (CMI Part number: 35-D044998)
- Programmable software. (Multi Auto Vcom 1.0.6)
- Document: Auto V-com adjustment suggestion OI. (CMI DCC number: 300019662)



## 6. INTERFACE TIMING

### 6.1 INPUT SIGNAL TIMING SPECIFICATIONS

(Ta = 25 ± 2 °C)

The input signal timing specifications are shown as the following table and timing diagram.

Signal	Item	Symbol	Min.	Typ.	Max.	Unit	Note
LVDS Receiver Clock	Frequency	$F_{clk_{in}}$ (=1/TC)	60	74.25	80	MHz	
	Input cycle to cycle jitter	$T_{rcj}$	-	-	200	ps	(3)
	Spread spectrum modulation range	$F_{clk_{in\_mod}}$	$F_{clk_{in}}-2\%$	-	$F_{clk_{in}}+2\%$	MHz	(4)
	Spread spectrum modulation frequency	$F_{SSM}$	-	-	200	KHz	
LVDS Receiver Data	Setup Time	$T_{lvsu}$	600	-	-	ps	(5)
	Hold Time	$T_{lvhd}$	600	-	-	ps	
Vertical Active Display Term	Frame Rate	$F_{r5}$	TBD	100	TBD	Hz	(6)
		$F_{r6}$	TBD	120	TBD	Hz	
	Total	$T_v$	1115	1125	1135	Th	$T_v=T_{vd}+T_{vb}$
	Display	$T_{vd}$	1080	1080	1080	Th	—
	Blank	$T_{vb}$	35	45	55	Th	—
Horizontal Active Display Term	Total	$T_h$	540	550	575	$T_c$	$T_h=T_{hd}+T_{hb}$
	Display	$T_{hd}$	480	480	480	$T_c$	—
	Blank	$T_{hb}$	60	70	95	$T_c$	—

Note (1) Since the module is operated in DE only mode, Hsync and Vsync input signals should be set to low logic level. Otherwise, this module would operate abnormally.

Note (2) Please make sure the range of pixel clock has follow the below equation:

$$F_{clk_{in}(max)} \geq F_{r6} \times T_v \times T_h$$

$$F_{r5} \times T_v \times T_h \geq F_{clk_{in}(min)}$$

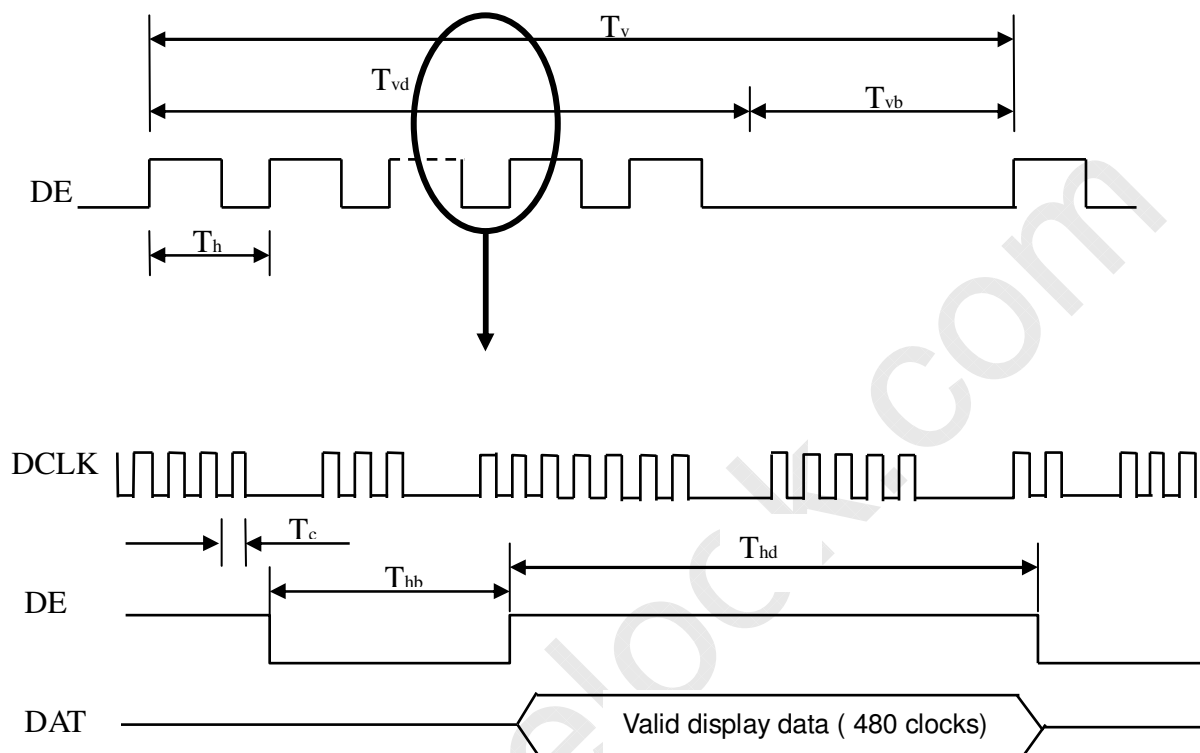
**INPUT SIGNAL TIMING DIAGRAM**

Note (3) The input clock cycle-to-cycle jitter is defined as below figures.  $Trcl = |T_1 - T_1|$

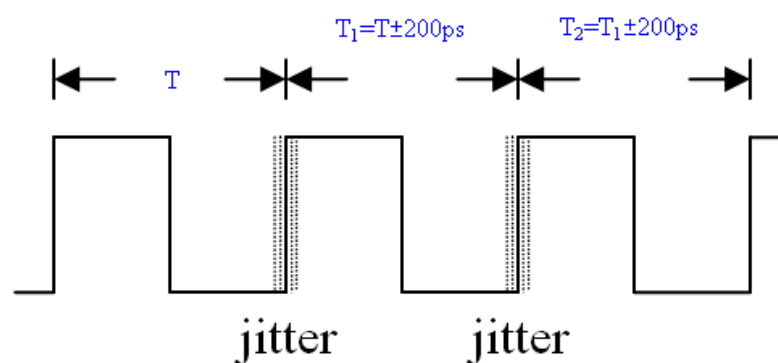

Note (4) The SSCG (Spread spectrum clock generator) is defined as below figures.

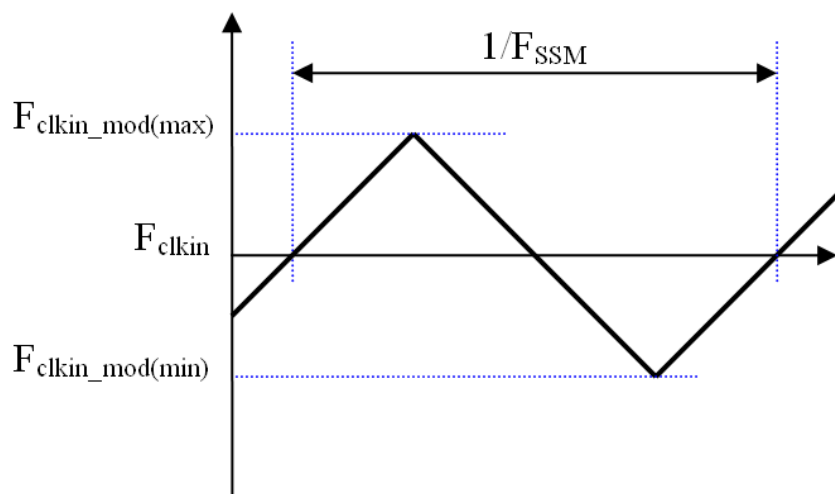

Note (5) The LVDS timing diagram and setup/hold time is defined and showing as the following figures.

### LVDS RECEIVER INTERFACE TIMING DIAGRAM

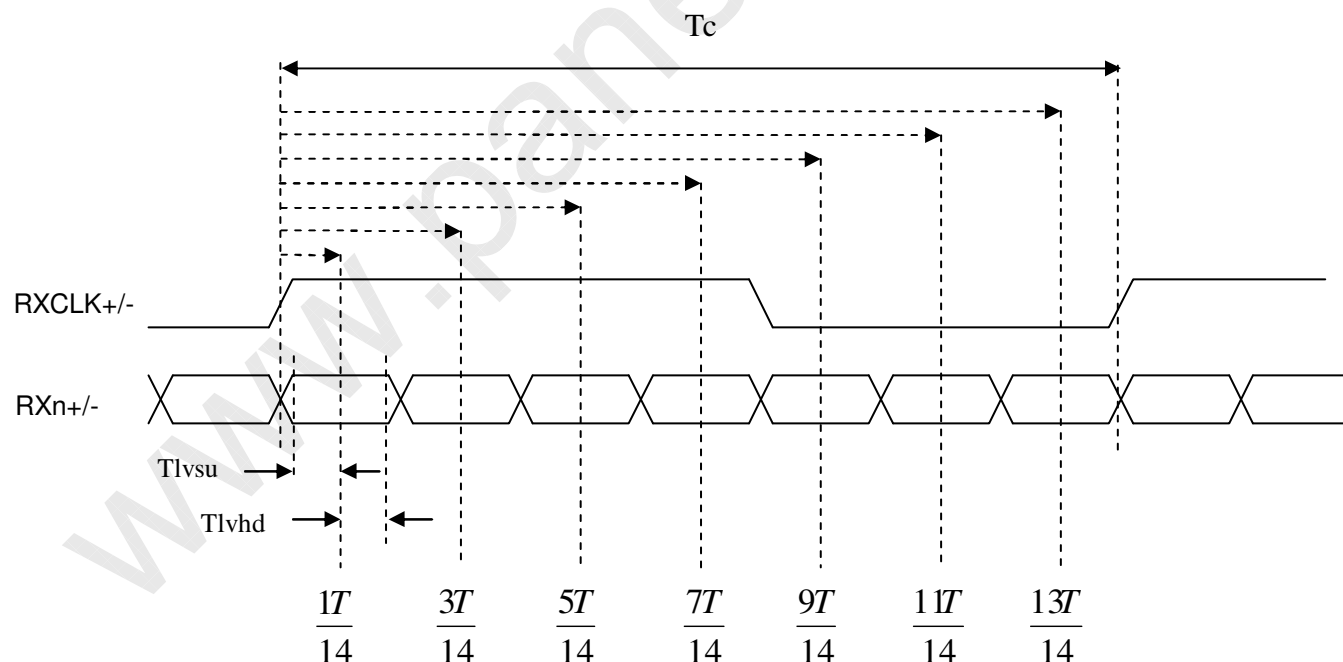

Note (6) : (ODSEL) = H/L or open for 100/120 Hz frame rate. Please refer to 5.1 for detail information

## 6.2 POWER ON/OFF SEQUENCE

( $T_a = 25 \pm 2 \text{ }^\circ\text{C}$ )

To prevent a latch-up or DC operation of LCD module, the power on/off sequence should be as the diagram below.

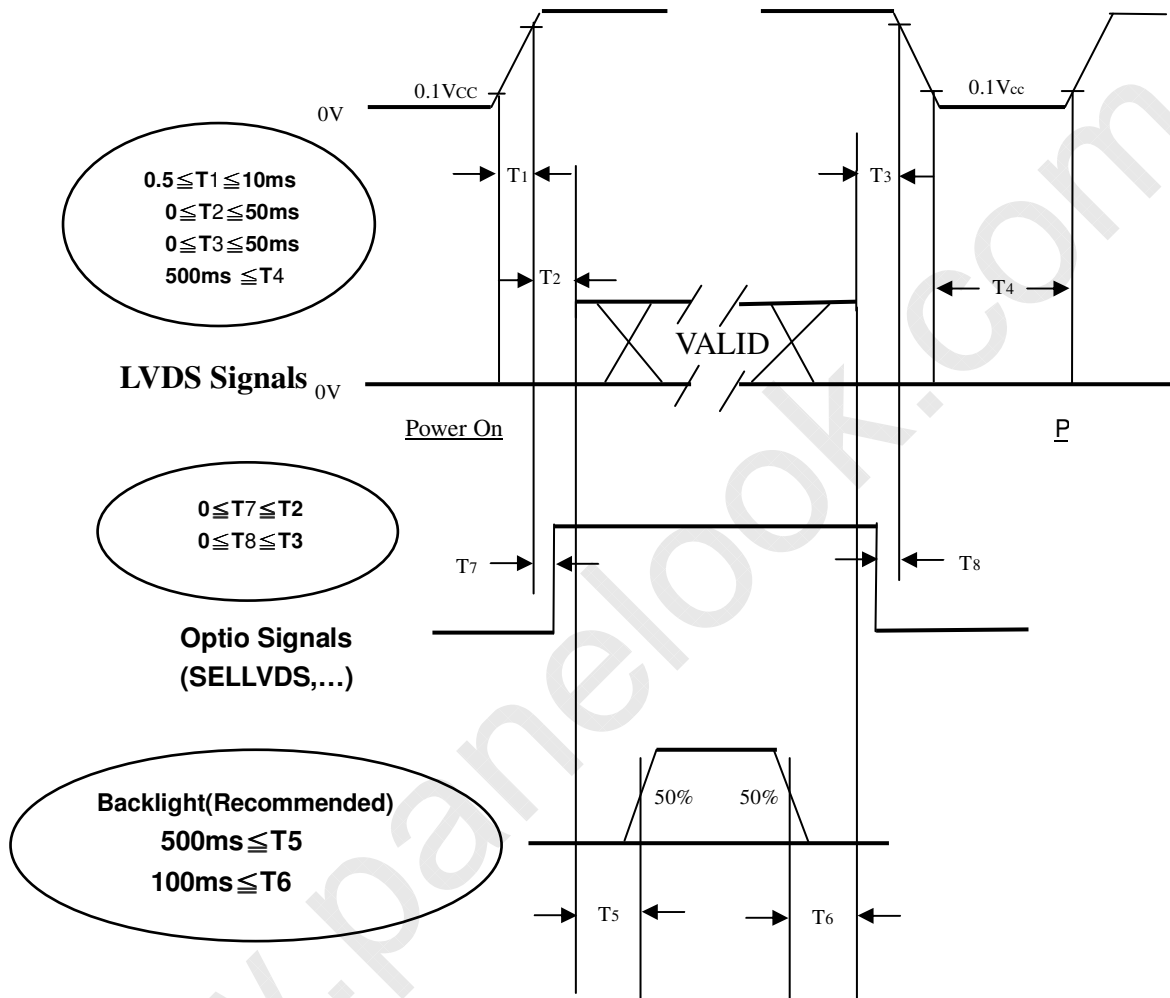

**Power ON/OFF Sequence**

Note (1) The supply voltage of the external system for the module input should follow the definition of Vcc.

Note (2) Apply the lamp voltage within the LCD operation range. When the backlight turns on before the LCD operation or the LCD turns off before the backlight turns off, the display may momentarily become abnormal screen.

Note (3) In case of Vcc is in off level, please keep the level of input signals on the low or high impedance. If  $T2 < 0$ , that maybe cause electrical overstress failure.

Note (4) T4 should be measured after the module has been fully discharged between power off and on period.

Note (5) Interface signal shall not be kept at high impedance when the power is on.

## 7. OPTICAL CHARACTERISTICS

### 7.1 TEST CONDITIONS

The LCD module should be stabilized at given temperature for 1 hour to avoid abrupt temperature change during measuring. In order to stabilize the luminance, the measurement should be executed after lighting backlight for 1 hour in a windless room.

Item	Symbol	Value	Unit
Ambient Temperature	Ta	25±2	°C
Ambient Humidity	Ha	50±10	%RH
Supply Voltage	V <sub>CC</sub>	12	V
Input Signal	According to typical value in "3. ELECTRICAL CHARACTERISTICS"		
Vertical Frame Rate	Fr	120	Hz

### 7.2 OPTICAL SPECIFICATIONS

The relative measurement methods of optical characteristics are shown in 7.2. The following items should be measured under the test conditions described in 7.1 and stable environment shown in 7.1.

Item	Symbol	Condition	Min.	Typ.	Max.	Unit	Note
Contrast Ratio	CR		4000	6000	-	-	(2), (4)
Response Time	Gray to gray	$\theta_x=0^\circ, \theta_y=0^\circ$ With CMO Module	-	5.5	10	ms	(5)
Center Transmittance	T%		-	4.8	-	%	(2), (8)
White Variation	$\delta W$		-	-	1.3	-	(2), (7)
Color Chromaticity	Red	Rcx	Typ - 0.03	0.650	Typ + 0.03	-	(1),(6)
		Rcy		0.327		-	
	Green	Gcx		0.297		-	
		Gcy		0.594		-	
	Blue	Bcx		0.134		-	
		Bcy		0.106		-	
	White	Wcx		0.310		-	
		Wcy		0.357		-	
Viewing Angle	Horizontal	$\theta_{x+}$	80	88	-	Deg.	(2), (3)
		$\theta_{x-}$	80	88	-		
	Vertical	$\theta_{y+}$	80	88	-		
		$\theta_{y-}$	80	88	-		

Note (1) Light source is the standard light source "C" which is defined by CIE and driving voltages are based on suitable gamma voltages. The calculating method is as following :

1. Measure Module's and BLU's spectrums. W, R, G, B are with signal input. BLU(for V420H2\_LE3) is supplied by CMO.
2. Calculate cell's spectrum.
3. Calculate cell's chromaticity by using the spectrum of standard light source "C"

Note (2) Light source is the BLU which is supplied by CMO and driving voltages are based on suitable gamma voltages.

Note (3) Definition of Viewing Angle ( $\theta_x, \theta_y$ ):

Viewing angles are measured by Conoscope Cono-80

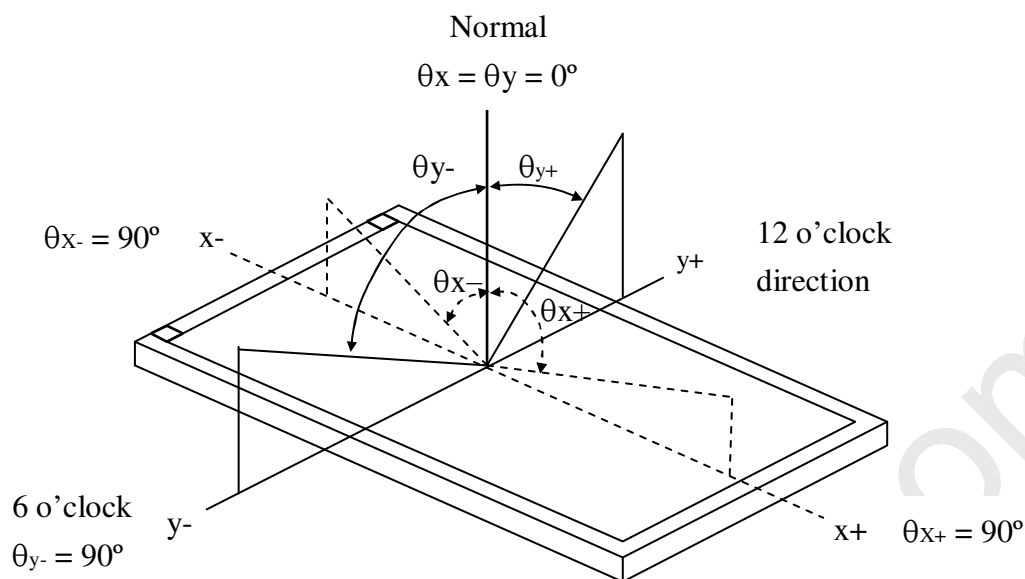
**Note (4) Definition of Contrast Ratio (CR):**

The contrast ratio can be calculated by the following expression.

$$\text{Contrast Ratio (CR)} = L_{255} / L_0$$

L 255: Luminance of gray level 255

L 0: Luminance of gray level 0

CR = CR (1), where CR (X) is corresponding to the Contrast Ratio of the point X at Figure in Note (7).

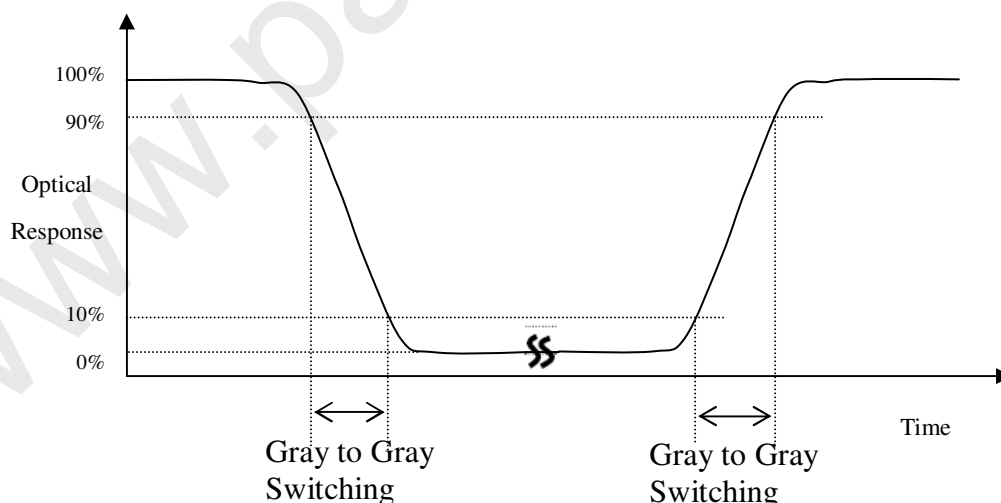
**Note (5) Definition of Gray to Gray Switching Time:**

The driving signal means the signal of gray level 0, 31, 63, 95, 127, 159, 191, 223 and 255.

Gray to gray average time means the average switching time of gray level 0, 31, 63, 95, 127, 159, 191, 223 and 255 to each other.

## Note (6) Measurement Setup:

The LCD module should be stabilized at given temperature for 1 hour to avoid abrupt temperature change during measuring. In order to stabilize the luminance, the measurement should be executed after lighting backlight for 1 hour in a windless room.

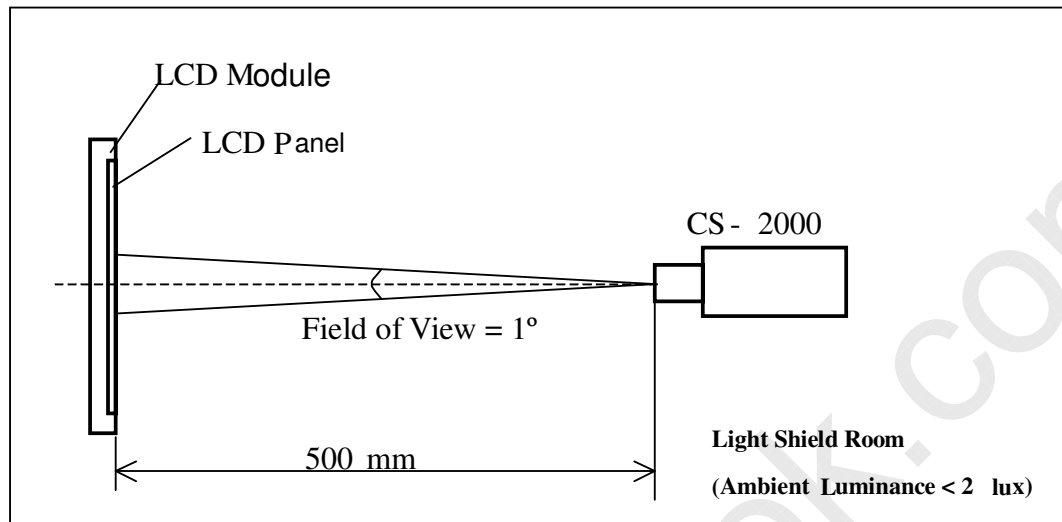

## Note (7) Definition of White Variation ( $\delta W$ ):

Measure the luminance of gray level 255 at 5 points

$$\delta W = \text{Maximum} [L(1), L(2), L(3), L(4), L(5)] / \text{Minimum} [L(1), L(2), L(3), L(4), L(5)]$$

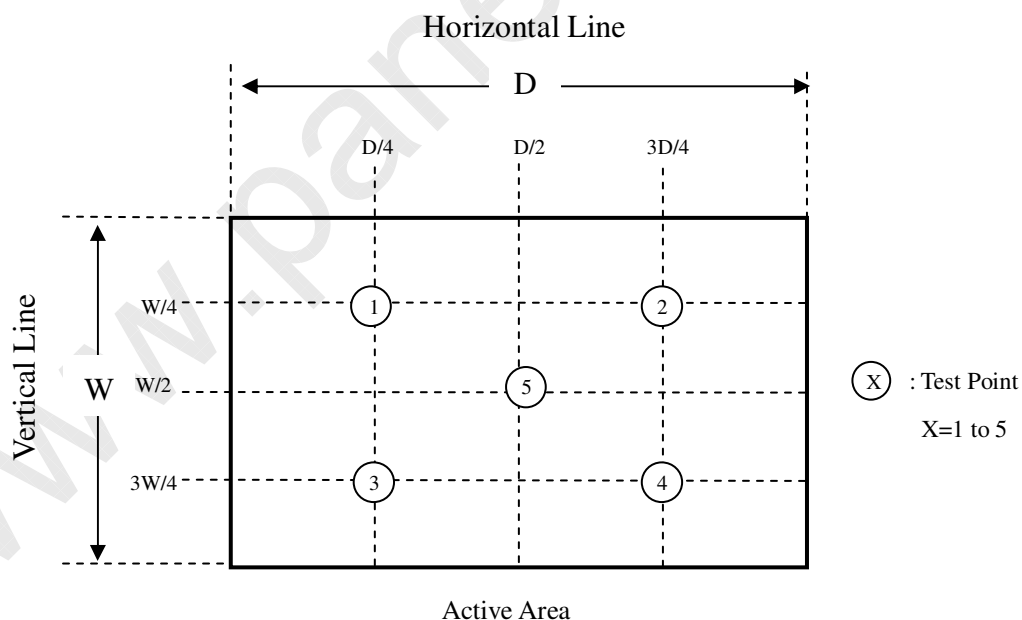

## Note (8) Definition of Transmittance (T%):

The measurement based on BLU (for V420H2\_LE3) with Three diffuser film.

$$\text{Transmittance} = \frac{\text{Luminance of LCD module}}{\text{Luminance of backlight}} * 100\%$$

## 8. DEFINITION OF LABELS

### 8.1 CMO MODULE LABEL

The barcode nameplate is pasted on each module as illustration, and its definitions are as following explanation.

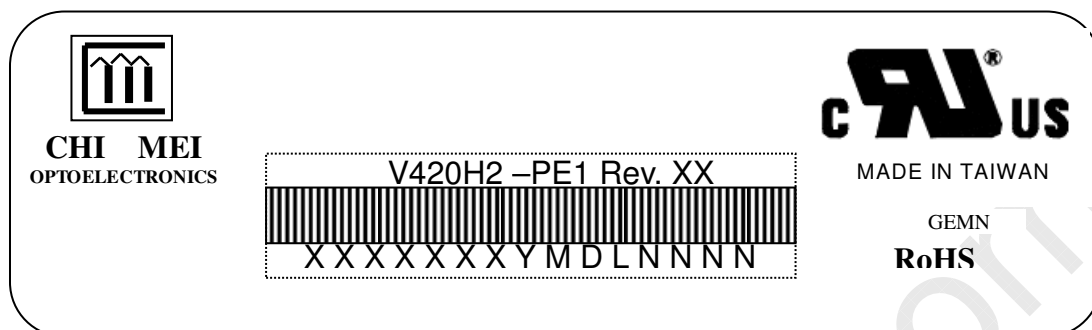

- (a) Model Name: V420H2-PE1  
 (b) Revision: Rev. XX, for example: A0, A1... B1, B2... or C1, C2...etc.  
 (c) Serial ID: XXXXXXXXXYMDLNNNN

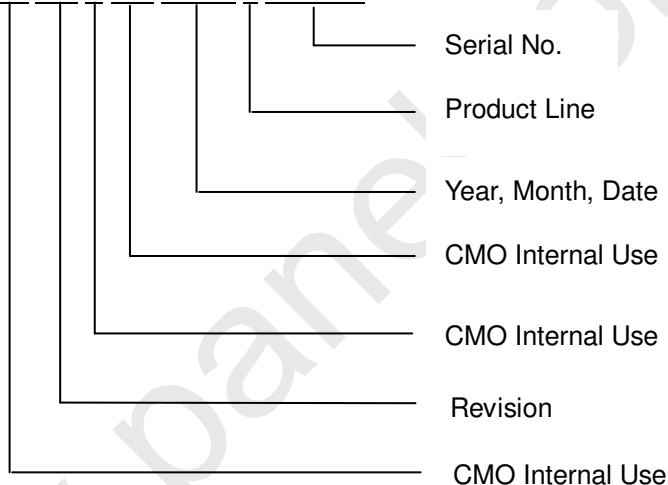

Serial ID includes the information as below:

- (a) Manufactured Date: Year: 2001=1, 2002=2, 2003=3, 2004=4...2010=0, 2011=1, 2012=2....  
 Month: 1~9, A~C, for Jan. ~ Dec.  
 Day: 1~9, A~Y, for 1<sup>st</sup> to 31<sup>st</sup>, exclude I ,O, and U.
- (b) Revision Code: Cover all the change  
 (c) Serial No.: Manufacturing sequence of product  
 (d) Product Line: 1 -> Line1, 2 -> Line 2, ...etc.



## 9. PACKAGING

### 9.1 PACKING SPECIFICATIONS

- (1) 9 LCD TV modules / 1 Box
- (2) Box dimensions : 1225 (L) X 801 (W) X 234 (H)mm
- (3) Weight : Approx. 34 Kg

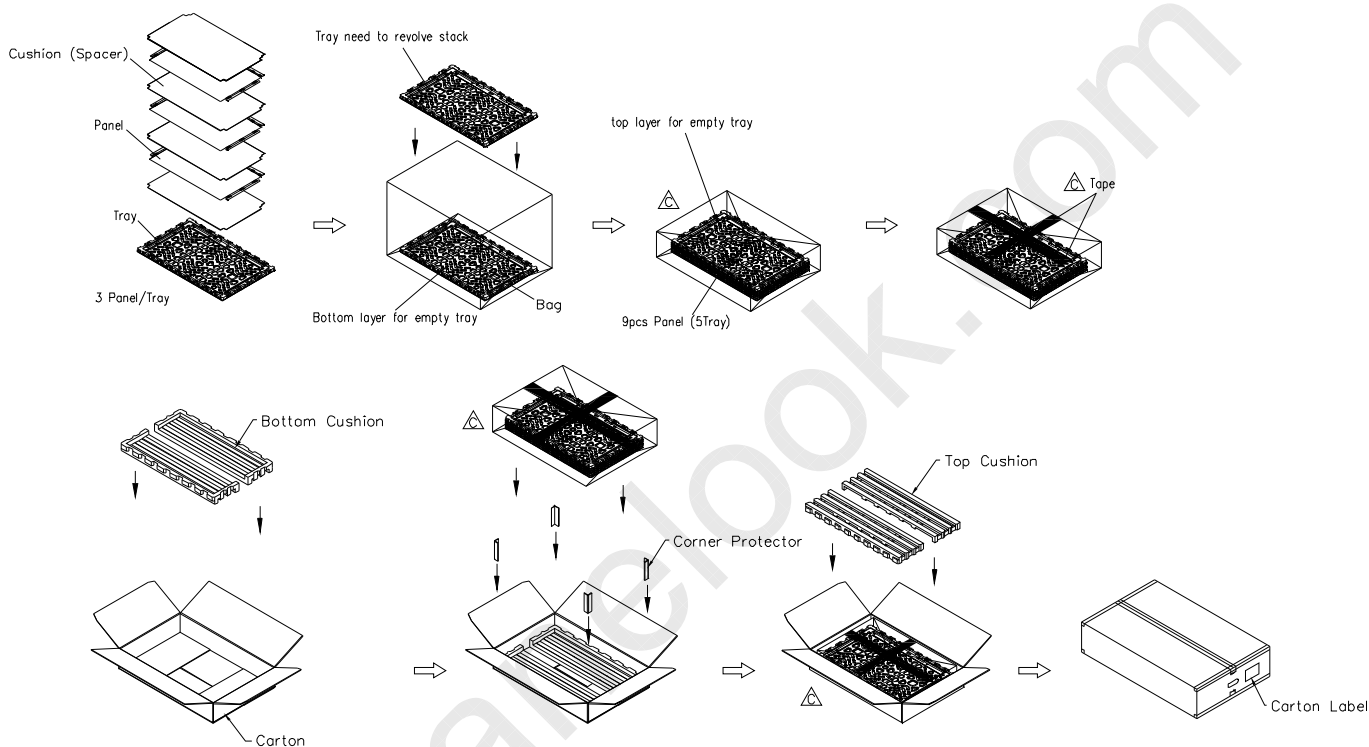



## 10. PRECAUTIONS

### 10.1 ASSEMBLY AND HANDLING PRECAUTIONS

- (1) Do not apply rough force such as bending or twisting to the module during assembly.
- (2) It is recommended to assemble or to install a module into the user's system in clean working areas. The dust and oil may cause electrical short or worsen the polarizer.
- (3) Do not apply pressure or impulse to the module to prevent the damage of LCD panel and backlight.
- (4) Always follow the correct power-on sequence when the LCD module is turned on. This can prevent the damage and latch-up of the CMOS LSI chips.
- (5) Do not plug in or pull out the I/F connector while the module is in operation.
- (6) Do not disassemble the module.
- (7) Use a soft dry cloth without chemicals for cleaning, because the surface of polarizer is very soft and easily scratched.
- (8) Moisture can easily penetrate into LCD module and may cause the damage during operation.
- (9) High temperature or humidity may deteriorate the performance of LCD module. Please store LCD modules in the specified storage conditions.
- (10) When ambient temperature is lower than 10°C, the display quality might be reduced. For example, the response time will become slow, and the starting voltage of LED light bar will be higher than that of room temperature.

### 10.2 SAFETY PRECAUTIONS

- (1) The startup voltage of a backlight is over 1000 Volts. It may cause an electrical shock while assembling with the converter. Do not disassemble the module or insert anything into the backlight unit.
- (2) If the liquid crystal material leaks from the panel, it should be kept away from the eyes or mouth. In case of contact with hands, skin or clothes, it has to be washed away thoroughly with soap.
- (3) After the module's end of life, it is not harmful in case of normal operation and storage.

