

**Features**

- JEDEC-standard 144 pin, Small-Outline, Dual in line Memory Module (SODIMM)
- Serial Presence Detect with E<sup>2</sup>PROM
- Nonbuffered
- Fully Synchronous, All Signals Registered on Positive Edge of System Clock
- Single +3.3V (± 0.3V) Power Supply
- All Device Pins are LVTTTL Compatible
- 4096 Refresh Cycles every 64 ms
- Self-Refresh Mode
- Internal Pipelined Operation; Column Address can be changed every System Clock
- Programmable Burst Lengths: 1, 2, 4, or 8
- Auto Precharge and Precharge all Banks by A10
- Data Mask Function by DQM
- Mode Register Set Programming
- Programmable (CAS Latency: 2, 3 Clocks)

The V43658Y04VATG-75 memory module is organized 8,388,608 x 64 bits in a 144 pin SODIMM. The 8M x 64 memory module uses 4 Mosel-Vitellic 8M x 16 SDRAM. The x64 modules are ideal for use in high performance computer systems where increased memory density and fast access times are required.

Part Number	Speed Grade	Configuration
V43658Y04VATG-75	-75 (133 MHz)	8M x 64

**Description**

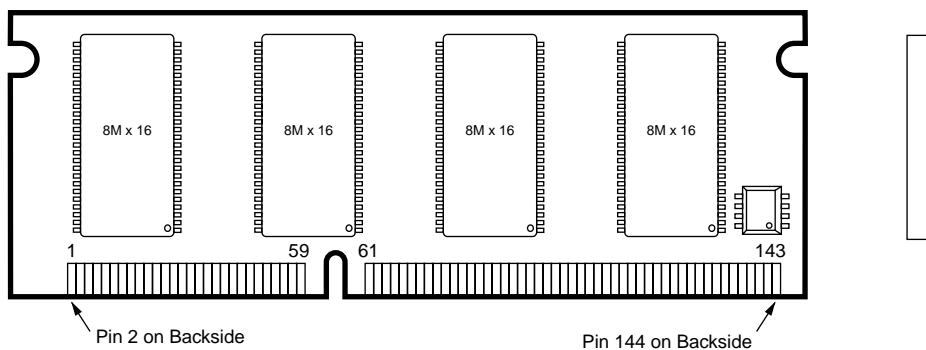

**Pin Configurations (Front Side/Back Side)**

Pin	Front	Pin	Front	Pin	Front	Pin	Back	Pin	Back	Pin	Back
1	VSS	25	DQMB1	49	DQ13	73	NC	97	DQ22	121	DQ24
2	VSS	26	DQMB5	50	DQ45	74	CLK1	98	DQ54	122	DQ56
3	DQ0	27	VDD	51	DQ14	75	VSS	99	DQ23	123	DQ25
4	DQ32	28	VDD	52	DQ46	76	VSS	100	DQ55	124	DQ57
5	DQ1	29	A0	53	DQ15	77	NC	101	VDD	125	DQ26
6	DQ33	30	A3	54	DQ47	78	NC	102	VDD	126	DQ58
7	DQ2	31	A1	55	VSS	79	NC	103	A6	127	DQ27
8	DQ34	32	A4	56	VSS	80	NC	104	A7	128	DQ59
9	DQ3	33	A2	57	NC	81	VDD	105	A8	129	VDD
10	DQ35	34	A5	58	NC	82	VDD	106	BA0	130	VDD
11	VDD	35	VSS	59	NC	83	DQ16	107	VSS	131	DQ28
12	VDD	36	VSS	60	NC	84	DQ48	108	VSS	132	DQ60
13	DQ4	37	DQ8	61	CLK0	85	DQ17	109	A9	133	DQ29
14	DQ36	38	DQ40	62	CKE0	86	DQ49	110	BA1	134	DQ61
15	DQ5	39	DQ9	63	VDD	87	DQ18	111	A10	135	DQ30
16	DQ37	40	DQ41	64	VDD	88	DQ50	112	A11	136	DQ62
17	DQ6	41	DQ10	65	$\overline{\text{RAS}}$	89	DQ19	113	VDD	137	DQ31
18	DQ38	42	DQ42	66	$\overline{\text{CAS}}$	90	DQ51	114	VDD	138	DQ63
19	DQ7	43	DQ11	67	$\overline{\text{WE}}$	91	VSS	115	DQMB2	139	VSS
20	DQ39	44	DQ43	68	CKE1	92	VSS	116	DQMB6	140	VSS
21	VSS	45	VDD	69	$\overline{\text{CS0}}$	93	DQ20	117	DQMB3	141	SDA
22	VSS	46	VDD	70	NC	94	DQ52	118	DQMB7	142	SCL
23	DQMB0	47	DQ12	71	$\overline{\text{CS1}}$	95	DQ21	119	VSS	143	VDD
24	DQMB4	48	DQ44	72	NC	96	DQ53	120	VSS	144	VDD

**Note:**

1.  $\overline{\text{RAS}}$ ,  $\overline{\text{CAS}}$ ,  $\overline{\text{WE}}$ ,  $\overline{\text{CASx}}$ ,  $\overline{\text{CSx}}$  are active low signals.

**Pin Names**

A0–A11, BA0, BA1	Address, Bank Select
DQ0–DQ63	Data Inputs/Outputs
$\overline{\text{RAS}}$	Row Address Strokes
$\overline{\text{CAS}}$	Column Address Strokes
$\overline{\text{WE}}$	Write Enable
$\overline{\text{CS0}}$ , $\overline{\text{CS1}}$	Chip Select
DQMB0–DQMB7	Output Enable
CKE0, CKE1	Clock Enable
CLK0–CLK1	Clock
SDA	Serial Input/Output
SCL	Serial Clock
VDD	Power Supply
VSS	Ground
NC	No Connect (Open)

**Part Number Information**

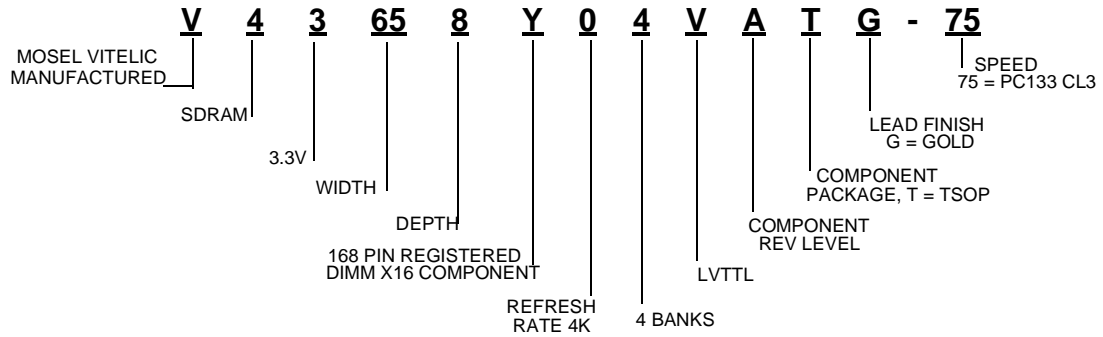

**Block Diagram**

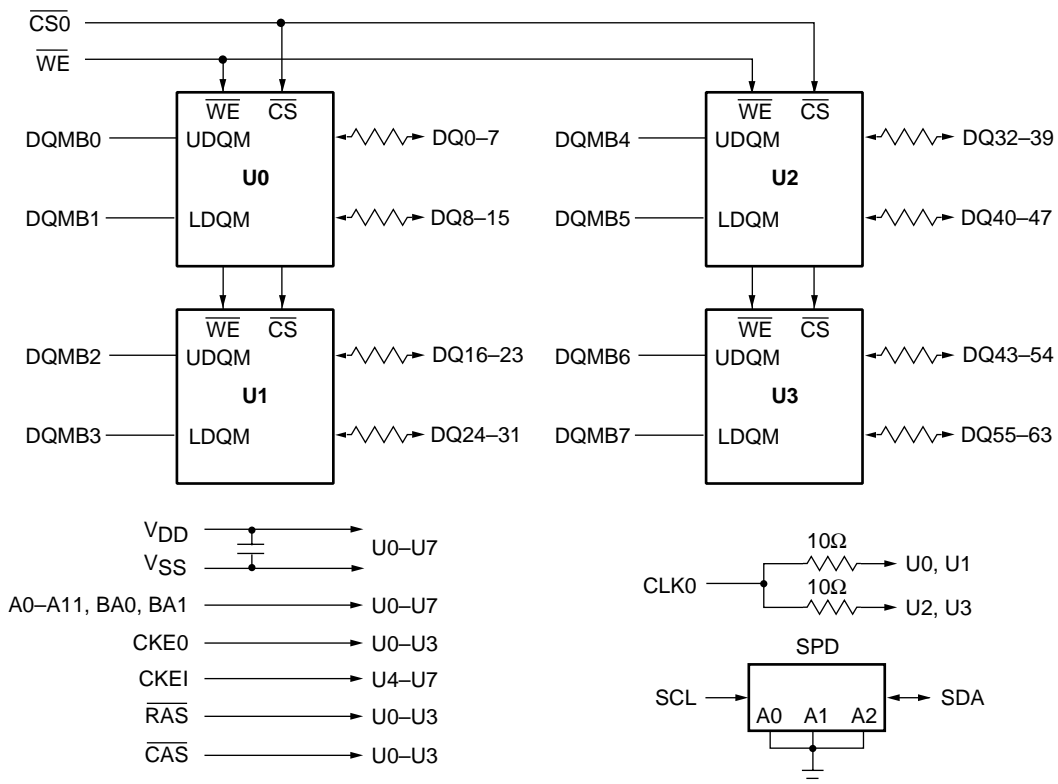

**Serial Presence Detect Information**

A serial presence detect storage device – E<sup>2</sup>PROM – is assembled onto the module. Information about the module configuration, speed, etc. is

written into the E<sup>2</sup>PROM device during module production using a serial presence detect protocol (I<sup>2</sup>C synchronous 2-wire bus)

**SPD-Table for -10 PC modules:**

Byte Number	Function Described	SPD Entry Value	Hex Value
			133 MHz -75
0	Number of SPD bytes	128	80
1	Total bytes in Serial PD	256	08
2	Memory Type	SDRAM	04
3	Number of Row Addresses (without BS bits)	12	0C
4	Number of Column Addresses (for x16 SDRAM)	9	09
5	Number of DIMM Banks	1	01
6	Module Data Width	64	40
7	Module Data Width (continued)	0	00
8	Module Interface Levels	LVTTTL	01
9	SDRAM Cycle Time at CL=3	7.5 ns	75
10	SDRAM Access Time from Clock at CL=3	5.4 ns	54
11	Dimm Config (Error Det/Corr.)	none	00
12	Refresh Rate/Type	Self-Refresh, 15.6µs	80
13	SDRAM width, Primary	x16	10
14	Error Checking SDRAM Data Width	n/a / x8	00
15	Minimum Clock Delay from Back to Back Random Column Address	t <sub>ccd</sub> = 1 CLK	01
16	Burst Length Supported	1, 2, 4, 8	0F
17	Number of SDRAM Banks	4	04
18	Supported $\overline{\text{CAS}}$ Latencies	CL = 3	04
19	$\overline{\text{CS}}$ Latencies	$\overline{\text{CS}}$ Latency = 0	01
20	$\overline{\text{WE}}$ Latencies	WL = 0	01
21	SDRAM DIMM Module Attributes	Non Buffered/Non Reg.	00
22	SDRAM Device Attributes: General	Vcc tol ± 10%	0E
23	Minimum Clock Cycle Time at $\overline{\text{CAS}}$ Latency = 2	Not Supported	00
24	Maximum Data Access Time from Clock for CL = 2	Not Supported	00
25	Minimum Clock Cycle Time at CL = 1	Not Supported	00
26	Maximum Data Access Time from Clock at CL = 1	Not Supported	00
27	Minimum Row Precharge Time t <sub>RP</sub>	20 ns	14
28	Minimum Row Active to Row Active Delay t <sub>RRD</sub>	15 ns	0F
29	Minimum RAS to $\overline{\text{CAS}}$ Delay t <sub>RCD</sub>	20 ns	14

**SPD-Table for -10 PC modules: (Continued)**

Byte Number	Function Described	SPD Entry Value	Hex Value
			133 MHz -75
30	Minimum RAS Pulse Width $t_{RAS}$	45 ns	2D
31	Module Bank Density (Per Bank)	64 MByte	10
32	SDRAM Input Setup Time	1.5 ns	15
33	SDRAM Input Hold Time	0.8 ns	08
34	SDRAM Data Input Setup Time	1.5 ns	15
35	SDRAM Data Input Hold Time	0.8 ns	08
36-61	Superset Information (May be used in Future)		00
62	SPD Revision	Revision 1.2	12
63	Checksum for Bytes 0 - 62		14
64	Manufacturer's JEDEC ID Code	Mosel Vitelic	40
65-71	Manufacturer's JEDEC ID Code (cont.)		00
72	Manufacturing Location	1 = US, 2 = Taiwan	
73-90	Module Part Number (ASCII)	V43658Y04VATG-75	
91-92	PCB Identification Code	Current PCB Revision	
93	Assembly Manufacturing Date (Year)	Binary Coded year (BCD)	
94	Assembly Manufacturing Date (Week)	Binary Coded week (BCD)	
95-98	Assembly Serial Number	byte 95 = LSB, byte 98 = MSB	
99-125	Reserved		00
126	Intel Specification for Frequency		64
127	Supported frequency		8D
128+	Unused Storage Location		00

**Absolute Maximum Ratings**

Parameter	Max.	Units
Voltage on VDD Supply Relative to $V_{SS}$	-1 to 4.6	V
Voltage on Input Relative to $V_{SS}$	-1 to 4.6	V
Operating Temperature	0 to +70	°C
Storage Temperature	-55 to 125	°C
Power Dissipation	1.5	W

**DC Characteristics**
 $T_A = 0^\circ\text{C to } 70^\circ\text{C}; V_{SS} = 0\text{ V}; V_{DD}, V_{DDQ} = 3.3\text{V} \pm 0.3\text{V}$ 

Symbol	Parameter	Limit Values		Unit
		Min.	Max.	
$V_{IH}$	Input High Voltage	2.0	$V_{CC}+0.3$	V
$V_{IL}$	Input Low Voltage	-0.5	0.8	V
$V_{OH}$	Output High Voltage ( $I_{OUT} = -2.0\text{ mA}$ )	2.4	—	V
$V_{OL}$	Output Low Voltage ( $I_{OUT} = 2.0\text{ mA}$ )	—	0.4	V
$I_{I(L)}$	Input Leakage Current, any input ( $0\text{ V} < V_{IN} < 3.6\text{ V}$ , all other inputs = 0V)	-10	10	$\mu\text{A}$
$I_{O(L)}$	Output leakage current (DQ is disabled, $0\text{V} < V_{OUT} < V_{CC}$ )	-10	10	$\mu\text{A}$

**Capacitance**
 $T_A = 0^\circ\text{C to } 70^\circ\text{C}; V_{DD} = 3.3\text{V} \pm 0.3\text{V}, f = 1\text{ MHz}$ 

Symbol	Parameter	Limit Values	Unit
$C_{I1}$	Input Capacitance (A0 to A11, $\overline{\text{RAS}}$ , $\overline{\text{CAS}}$ , $\overline{\text{WE}}$ )	105	pF
$C_{I2}$	Input Capacitance ( $\overline{\text{CS0}}$ , $\overline{\text{CS1}}$ )	32	pF
$C_{ICL}$	Input Capacitance (CLK0-CLK1)	40	pF
$C_{I3}$	Input Capacitance (CKE0, CKE1)	65	pF
$C_{I4}$	Input Capacitance (DQMB0-DQMB7)	20	pF
$C_{SC}$	Input Capacitance (SCL, SA0-2)	8	pF
$C_{IO}$	Input/Output Capacitance	10	pF

**Standby and Refresh Currents<sup>1</sup>**
 $T_A = 0^\circ\text{C to } 70^\circ\text{C}, V_{CC} = 3.3\text{V} \pm 0.3\text{V}$ 

Symbol	Parameter	Test Conditions	8M x 64	Unit	Note
$I_{CC1}$	Operating Current	Burst length = 4, CL = 3 $t_{RC} > t_{RC}(\text{min}), t_{CK} > t_{CK}(\text{min})$	680	mA	1,2
$I_{CC2P}$	Precharged Standby Current in Power Down Mode	$\text{CKE} < V_{IL}(\text{max}), t_{CK} > t_{CK}(\text{min})$	6	mA	
$I_{CC2N}$	Precharged Standby Current in Non-Power Down Mode	$\text{CKE} > V_{IH}(\text{min}), t_{CK} > t_{CK}(\text{min})$ , Input changed once in 3 cycles	180	mA	$\overline{\text{CS}} = \text{High}$
$I_{CC3P}$	Active Standby Current in Power Down Mode	$\text{CKE} < V_{IL}(\text{max}), t_{CK} > t_{CK}(\text{min})$	40	mA	
$I_{CC3N}$	Active Standby Current in Non-Power Down Mode	$\text{CKE} > V_{IH}(\text{min}), t_{CK} > t_{CK}(\text{min})$ , Input changed one time	220	mA	$\overline{\text{CS}} = \text{High}$
$I_{CC4}$	Burst Operating Current	$t_{RC} = \text{Infinite}, \text{CL} = 3, t_{CK} > t_{CK}(\text{min})$	440	mA	1, 2
$I_{CC5}$	Auto Refresh Current	$t_{RC} > t_{RC}(\text{min})$	1000	mA	1,2
$I_{CC6}$	Self Refresh Current	$\text{CKE} = < 0,2\text{ V}$	6	mA	1,2
		L-Version	3.2	mA	

**AC Characteristics** <sup>3,4</sup>

$T_A = 0^\circ$  to  $70^\circ\text{C}$ ;  $V_{SS} = 0\text{V}$ ;  $V_{CC} = 3.3\text{V} \pm 0.3\text{V}$ ,  $t_T = 1\text{ ns}$

#	Symbol	Parameter	Limit Values		Unit	Note
			-75			
			Min.	Max.		
<b>Clock and Clock Enable</b>						
1	$t_{CK}$	Clock Cycle Time CAS Latency = 3 CAS Latency = 2	7.5 10	– –	s ns ns	
2	$t_{CK}$	Clock Frequency CAS Latency = 3 CAS Latency = 2	– –	133 100	MHz MHz	
3	$t_{AC}$	Access Time from Clock CAS Latency = 3 CAS Latency = 2	– –	5.4 6	ns ns	2, 4
4	$t_{CH}$	Clock High Pulse Width	2.5	–	ns	
5	$t_{CL}$	Clock Low Pulse Width	2.5	–	ns	
6	$t_T$	Transition Tim	0.3	1.2	ns	
<b>Setup and Hold Times</b>						
7	$t_{IS}$	Input Setup Time	1.5	–	ns	5
8	$t_{IH}$	Input Hold Time	0.8	–	ns	5
9	$t_{CKS}$	Input Setup Time	1.5	–	ns	5
10	$t_{CKH}$	CKE Hold Time	0.8	–	ns	5
11	$t_{RSC}$	Mode Register Set-up Time	15	–	ns	
12	$t_{SB}$	Power Down Mode Entry Time	0	7.5	ns	
<b>Common Parameters</b>						
13	$t_{RCD}$	Row to Column Delay Time	20	–	ns	6
14	$t_{RP}$	Row Precharge Time	20	–	ns	6
15	$t_{RAS}$	Row Active Time	45	100K	ns	6
16	$t_{RC}$	Row Cycle Time	60	–	ns	6
17	$t_{RRD}$	Activate(a) to Activate(b) Command Period	15	–	ns	6
18	$t_{CCD}$	CAS(a) to CAS(b) Command Period	1	–	CLK	
<b>Refresh Cycle</b>						
19	$t_{REF}$	Refresh Period (4096 cycles)	–	64	ms	
20	$t_{SREX}$	Self Refresh Exit Time	10	–	ns	
<b>Read Cycle</b>						
21	$t_{OH}$	Data Out Hold Time	2.7	–	ns	2
22	$t_{LZ}$	Data Out to Low Impedance Time	1	–	ns	
23	$t_{HZ}$	Data Out to High Impedance Time	–	5.4	ns	7
24	$t_{DQZ}$	DQM Data Out Disable Latency	–	2	CLK	
<b>Write Cycle</b>						
25	$t_{WR}$	Write Recovery Time	1	–	CLK	
26	$t_{DQW}$	DQM Write Mask Latency	0	–	CLK	

**Notes:**

1. The specified values are valid when addresses are changed no more than once during  $t_{CK}(\text{min.})$  and when No Operation commands are registered on every rising clock edge during  $t_{RC}(\text{min.})$ . Values are shown per module bank.
2. The specified values are valid when data inputs (DQ's) are stable during  $t_{RC}(\text{min.})$ .
3. All AC characteristics are shown for device level.  
An initial pause of 100  $\mu\text{s}$  is required after power-up, then a Precharge All Banks command must be given followed by 8 Auto Refresh (CBR) cycles before the Mode Register Set Operation can begin.
4. AC timing tests have  $V_{IL} = 0.4\text{V}$  and  $V_{IH} = 2.4\text{V}$  with the timing referenced to the 1.4V crossover point. The transition time is measured between  $V_{IH}$  and  $V_{IL}$ . All AC measurements assume  $t_T = 1 \text{ ns}$  with the AC output load circuit shown. Specific  $t_{ac}$  and  $t_{oh}$  parameters are measured with a 50 pF only, without any resistive termination and with a input signal of 1V / ns edge rate between 0.8V and 2.0V.

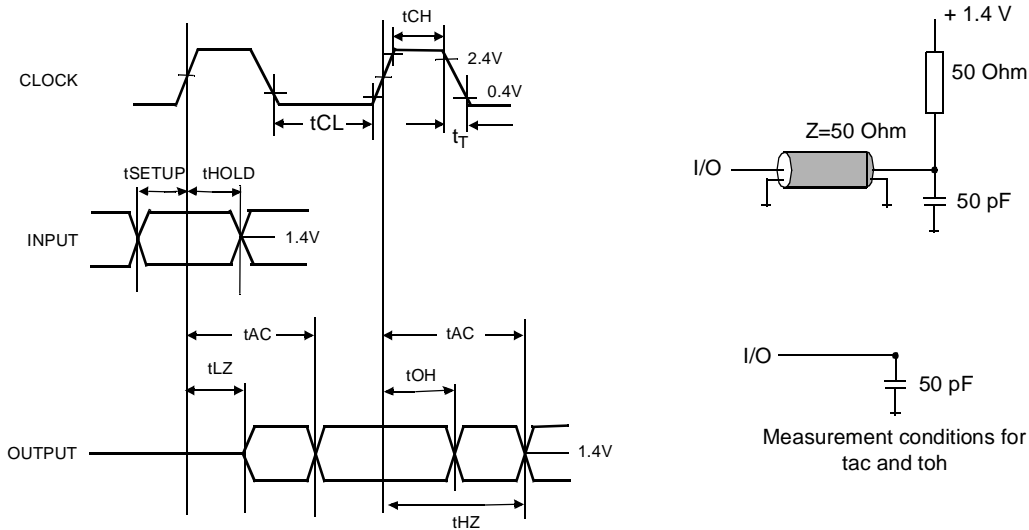

5. If clock rising time is longer than 1 ns, a time  $(t_T/2 - 0.5)$  ns has to be added to this parameter.
6. Rated at 1.5V
7. If  $t_T$  is longer than 1 ns, a time  $(t_T - 1)$  ns has to be added to this parameter.
8. Any time that the refresh Period has been exceeded, a minimum of two Auto (CBR) Refresh commands must be given to "wake-up" the device.
9. Self Refresh Exit is a synchronous operation and begins on the 2nd positive clock edge after CKE returns high. Self Refresh Exit is not complete until a time period equal to  $t_{RC}$  is satisfied once the Self Refresh Exit command is registered.
10. Referenced to the time which the output achieves the open circuit condition, not to output voltage levels.
11.  $t_{DAL}$  is equivalent to  $t_{DPL} + t_{RP}$ .

**Package Diagram**



*Package Diagram*

**144 Pin SODIMM**

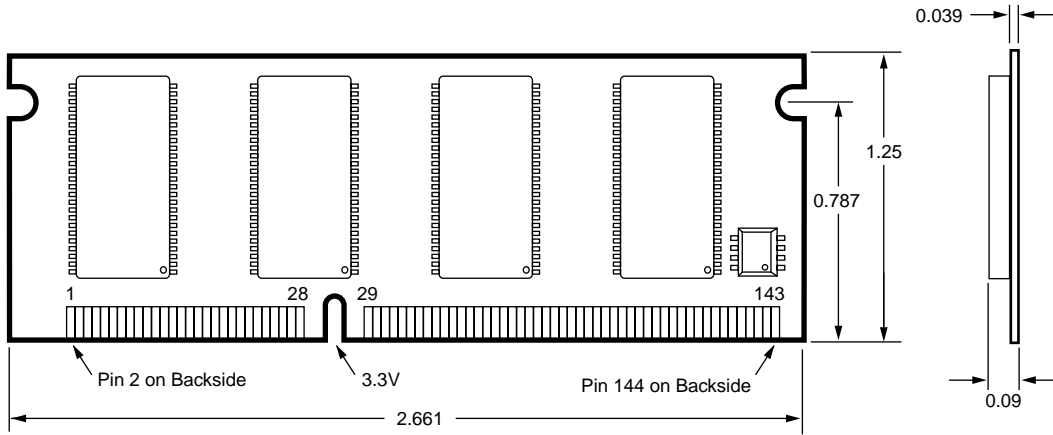

**NOTE:**

- 1. All dimensions in inches.  
Tolerances  $\pm 0.005$  unless otherwise specified.

**Label Information**

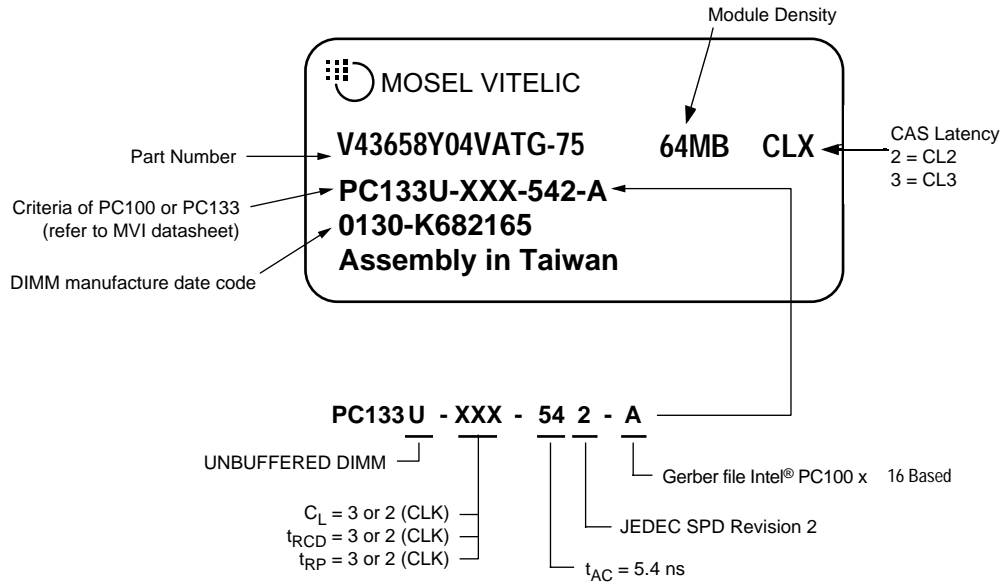

**U.S.A.**

3910 NORTH FIRST STREET  
SAN JOSE, CA 95134  
PHONE: 408-433-6000  
FAX: 408-433-0952

**TAIWAN**

7F, NO. 102  
MIN-CHUAN E. ROAD, SEC. 3  
TAIPEI  
PHONE: 886-2-2545-1213  
FAX: 886-2-2545-1209

NO 19 LI HSIN ROAD  
SCIENCE BASED IND. PARK  
HSIN CHU, TAIWAN, R.O.C.  
PHONE: 886-3-579-5888  
FAX: 886-3-566-5888

**SINGAPORE**

10 ANSON ROAD #23-13  
INTERNATIONAL PLAZA  
SINGAPORE 079903  
PHONE: 65-3231801  
FAX: 65-3237013

**JAPAN**

ONZE 1852 BUILDING 6F  
2-14-6 SHINTOMI, CHUO-KU  
TOKYO 104-0041  
PHONE: 03-3537-1400  
FAX: 03-3537-1402

**UK & IRELAND**

SUITE 50, GROVEWOOD  
BUSINESS CENTRE  
STRATHCLYDE BUSINESS  
PARK  
BELLSHILL, LANARKSHIRE,  
SCOTLAND, ML4 3NQ  
PHONE: 44-1698-748515  
FAX: 44-1698-748516

**GERMANY  
(CONTINENTAL  
EUROPE & ISRAEL)**

BENZSTRASSE 32  
71083 HERRENBERG  
GERMANY  
PHONE: +49 7032 2796-0  
FAX: +49 7032 2796 22

**U.S. SALES OFFICES****NORTHWESTERN**

3910 NORTH FIRST STREET  
SAN JOSE, CA 95134  
PHONE: 408-433-6000  
FAX: 408-433-0952

**SOUTHWESTERN**

302 N. EL CAMINO REAL #200  
SAN CLEMENTE, CA 92672  
PHONE: 949-361-7873  
FAX: 949-361-7807

**CENTRAL,  
NORTHEASTERN &  
SOUTHEASTERN**

604 FIELDWOOD CIRCLE  
RICHARDSON, TX 75081  
PHONE: 214-352-3775  
FAX: 214-904-9029

---

The information in this document is subject to change without notice.

MOSEL VITELIC makes no commitment to update or keep current the information contained in this document. No part of this document may be copied or reproduced in any form or by any means without the prior written consent of MOSEL-VITELIC.

MOSEL VITELIC subjects its products to normal quality control sampling techniques which are intended to provide an assurance of high quality products suitable for usual commercial applications. MOSEL VITELIC does not do testing appropriate to provide 100% product quality assurance and does not assume any liability for consequential or incidental arising from any use of its products. If such products are to be used in applications in which personal injury might occur from failure, purchaser must do its own quality assurance testing appropriate to such applications.