

**Features**

- 168 Pin Unbuffered ECC 33,554,432 x 72 bit Organization SDRAM Modules
- Utilizes High Performance 32M x 8 SDRAM in TSOPII-54 Packages
- Fully PC Board Layout Compatible to INTEL'S Rev 1.0 Module Specification
- Single +3.3V (± 0.3V) Power Supply
- Programmable  $\overline{\text{CAS}}$  Latency, Burst Length, and Wrap Sequence (Sequential & Interleave)
- Auto Refresh (CBR) and Self Refresh
- All Inputs, Outputs are LVTTTL Compatible
- 8192 Refresh Cycles every 64 ms
- Serial Present Detect (SPD)
- SDRAM Performance

**Description**

The V437432S24V memory module is organized 33,554,432 x 72 bits in a 168 pin dual in line memory module (DIMM). The 32M x 72 unbuffered DIMM uses 9 Mosel-Vitellic 32M x 8 ECC SDRAM. The x72 modules are ideal for use in high performance computer systems where increased memory density and fast access times are required.

Key Component Timing Parameters		-7PC	Units
$t_{CK}$	Clock Frequency (max.)	143	MHz
$t_{AC}$	Clock Access Time $\overline{\text{CAS}}$ Latency = 3	5.4	ns
$t_{CK}$	Clock Frequency (max.)	133	MHz
$t_{AC}$	Clock Access Time $\overline{\text{CAS}}$ Latency = 2	5.4	ns

■ Module Frequency vs AC Parameter

Frequency	$\overline{\text{CL}}$ (CAS Latency)	$t_{RCD}$	$t_{RP}$	$t_{RC}$	Unit
V437432S24V 133 MHz (PC)	2	2	2	8	CLK

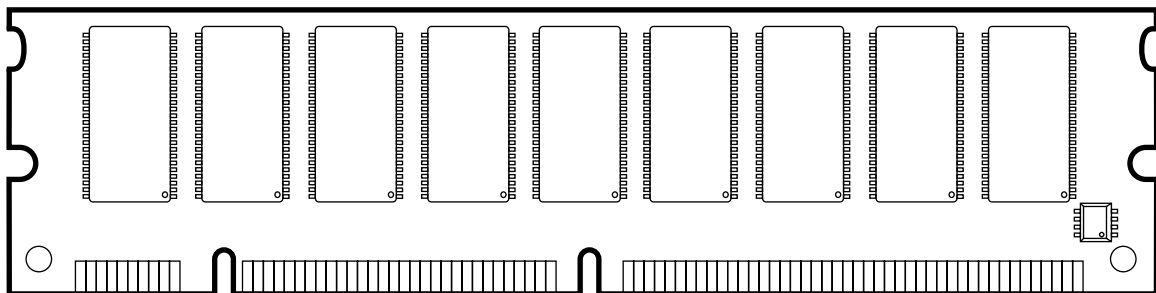

**Pin Configurations (Front Side/Back Side)**

Pin	Front	Pin	Front	Pin	Front	Pin	Back	Pin	Back	Pin	Back
1	VSS	29	DQM1	57	I/O19	85	VSS	113	DQM5	141	I/O51
2	I/O1	30	$\overline{\text{CS}}0$	58	I/O20	86	I/O33	114	$\overline{\text{CS}}1$	142	I/O52
3	I/O2	31	DU	59	VCC	87	I/O34	115	RAS	143	VCC
4	I/O3	32	VSS	60	I/O21	88	I/O35	116	VSS	144	I/O53
5	I/O4	33	A0	61	NC	89	I/O36	117	A1	145	NC
6	VCC	34	A2	62	DU	90	VCC	118	A3	146	DU
7	I/O5	35	A4	63	CKE1	91	I/O37	119	A5	147	NC
8	I/O6	36	A6	64	VSS	92	I/O38	120	A7	148	VSS
9	I/O7	37	A8	65	I/O22	93	I/O39	121	A9	149	I/O54
10	I/O8	38	A10(AP)	66	I/O23	94	I/O40	122	BA0	150	I/O55
11	I/O9	39	BA1	67	I/O24	95	I/O41	123	A11	151	I/O56
12	VSS	40	VCC	68	VSS	96	VSS	124	VCC	152	VSS
13	I/O10	41	VCC	69	I/O25	97	I/O42	125	CLK1	153	I/O57
14	I/O11	42	CLK0	70	I/O26	98	I/O43	126	A12	154	I/O58
15	I/O12	43	VSS	71	I/O27	99	I/O44	127	VSS	155	I/O59
16	I/O13	44	DU	72	I/O28	100	I/O45	128	$\overline{\text{CKE}}0$	156	I/O60
17	I/O14	45	$\overline{\text{CS}}2$	73	VCC	101	I/O46	129	$\overline{\text{CS}}3$	157	VCC
18	VCC	46	DQM2	74	I/O29	102	VCC	130	DQM6	158	I/O61
19	I/O15	47	DQM3	75	I/O30	103	I/O47	131	DQM7	159	I/O62
20	I/O16	48	DU	76	I/O31	104	I/O48	132	DU	160	I/O63
21	CBO*	49	VCC	77	I/O32	105	CB4*	133	VCC	161	I/O64
22	CB1*	50	NC	78	VSS	106	CB5*	134	NC	162	VSS
23	VSS	51	NC	79	CLK2	107	VSS	135	NC	163	CLK3
24	NC	52	CB2*	80	NC	108	NC	136	CB6*	164	NC
25	NC	53	CB3*	81	WP	109	NC	137	CB7*	165	SA0
26	VCC	54	VSS	82	SDA	110	VCC	138	VSS	166	SA1
27	$\overline{\text{WE}}$	55	I/O17	83	SCL	111	CAS	139	I/O49	167	SA2
28	DQM0	56	I/O18	84	VCC	112	DQM4	140	I/O50	168	VCC

**Notes:**

\* These pins are not used in this module.

**Pin Names**

A0–A12	Address Inputs
I/O1–I/O64	Data Inputs/Outputs
$\overline{\text{RAS}}$	Row Address Strobe
$\overline{\text{CAS}}$	Column Address Strobe
$\overline{\text{WE}}$	Read/Write Input
BA0, BA1	Bank Selects
$\overline{\text{CKE}}0, \overline{\text{CKE}}1$	Clock Enable
$\overline{\text{CS}}0$ – $\overline{\text{CS}}3$	Chip Select
CLK0–CLK3	Clock Input
DQM0–DQM7	Data Mask
VCC	Power (+3.3 Volts)
VSS	Ground
SCL	Clock for Presence Detect

SDA	Serial Data OUT for Presence Detect
SA0–A2	Serial Data IN for Presence Detect
CB0–CB7	Check Bits (x72 Organization)
NC	No Connection
DU	Don't Use

**Module Part Number Information**

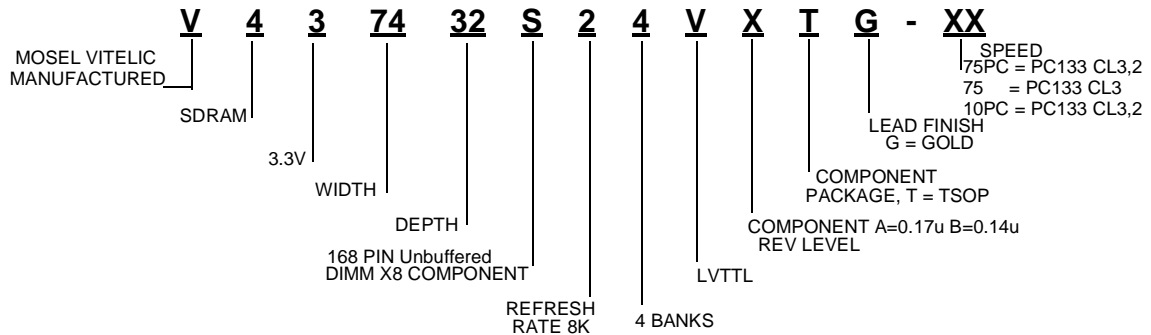

**Block Diagram**

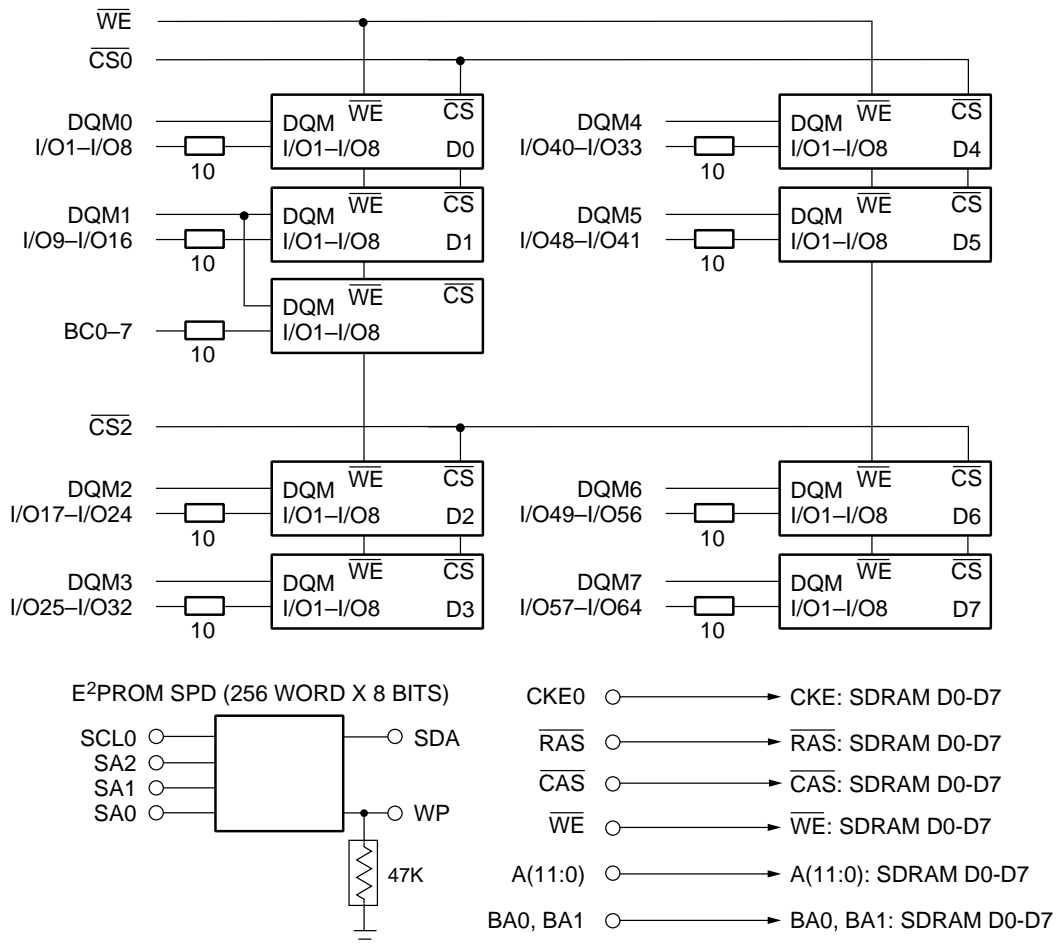

CLOCK WIRING	
CLOCK INPUT	LOAD
CLK0	5 SDRAM
CLK1	Termination
CLK2	4 SDRAMS +3.3pF Cap
CLK3	Termination

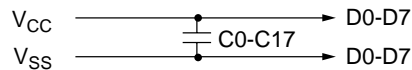

**Serial Presence Detect Information**

A serial presence detect storage device – E<sup>2</sup>PROM – is assembled onto the module. Information about the module configuration, speed, etc. is

written into the E<sup>2</sup>PROM device during module production using a serial presence detect protocol (I<sup>2</sup>C synchronous 2-wire bus)

**SPD-Table for 75 modules:**

Byte Number	Function Described	SPD Entry Value	Hex Value
			32Mx72
0	Number of SPD bytes	128	80
1	Total bytes in Serial PD	256	08
2	Memory Type	SDRAM	04
3	Number of Row Addresses (without BS bits)	13	0D
4	Number of Column Addresses (for x8 SDRAM)	10	0A
5	Number of DIMM Banks	1	01
6	Module Data Width	72	48
7	Module Data Width (continued)	0	00
8	Module Interface Levels	LVTTL	01
9	SDRAM Cycle Time at CL=3	7.5 ns	75
10	SDRAM Access Time from Clock at CL=3	5.4 ns	54
11	Dimm Config (Error Det/Corr.)	ECC	02
12	Refresh Rate/Type	Self-Refresh, 7.8µs	82
13	SDRAM width, Primary	x8	08
14	Error Checking SDRAM Data Width	n/a / x8	08
15	Minimum Clock Delay from Back to Back Random Column Address	t <sub>ccd</sub> = 1 CLK	01
16	Burst Length Supported	1, 2, 4, 8	0F
17	Number of SDRAM Banks	4	04
18	Supported $\overline{\text{CAS}}$ Latencies	CL = 2,3	06
19	$\overline{\text{CS}}$ Latencies	$\overline{\text{CS}}$ Latency = 0	01
20	$\overline{\text{WE}}$ Latencies	WL = 0	01
21	SDRAM DIMM Module Attributes	Non Buffered/Non Reg.	00
22	SDRAM Device Attributes: General	V <sub>cc</sub> tol ± 10%	0E
23	Minimum Clock Cycle Time at $\overline{\text{CAS}}$ Latency = 2	7.5 ns	75
24	Maximum Data Access Time from Clock for CL = 2	5.4 ns	54
25	Minimum Clock Cycle Time at CL = 1	Not Supported	00
26	Maximum Data Access Time from Clock at CL = 1	Not Supported	00
27	Minimum Row Precharge Time	15 ns	0F
28	Minimum Row Active to Row Active Delay t <sub>RRD</sub>	14 ns	0E
29	Minimum RAS to $\overline{\text{CAS}}$ Delay t <sub>RCD</sub>	15 ns	0F
30	Minimum RAS Pulse Width t <sub>RAS</sub>	42 ns	2A

**SPD-Table for 75 modules: (Continued)**

Byte Number	Function Described	SPD Entry Value	Hex Value
			32Mx72
31	Module Bank Density (Per Bank)	256 MByte	40
32	SDRAM Input Setup Time	1.5 ns	15
33	SDRAM Input Hold Time	0.8 ns	08
34	SDRAM Data Input Setup Time	1.5 ns	15
35	SDRAM Data Input Hold Time	0.8 ns	08
62-61	Superset Information (May be used in Future)		00
62	SPD Revision	Revision 2	02
63	Checksum for Bytes 0 - 62		0F
64	Manufacturer's JEDEC ID Code	Mosel Vitelic	40
65-71	Manufacturer's JEDEC ID Code (cont.)		00
72	Manufacturing Location		
73-90	Module Part Number (ASCII)	V437432S24V	
91-92	PCB Identification Code		
93	Assembly Manufacturing Date (Year)		
94	Assembly Manufacturing Date (Week)		
95-98	Assembly Serial Number		
99-125	Reserved		00
126	Intel Specification for Frequency		64
127	Reserved		AF
128+	Unused Storage Location		00

**DC Characteristics**

$T_A = 0^{\circ}\text{C}$  to  $70^{\circ}\text{C}$ ;  $V_{SS} = 0\text{ V}$ ;  $V_{DD}, V_{DDQ} = 3.3\text{V} \pm 0.3\text{V}$

Symbol	Parameter	Limit Values		Unit
		Min.	Max.	
$V_{IH}$	Input High Voltage	2.0	$V_{CC}+0.3$	V
$V_{IL}$	Input Low Voltage	-0.5	0.8	V
$V_{OH}$	Output High Voltage ( $I_{OUT} = -4.0\text{ mA}$ )	2.4	—	V
$V_{OL}$	Output Low Voltage ( $I_{OUT} = 4.0\text{ mA}$ )	—	0.4	V
$I_{I(L)}$	Input Leakage Current, any input ( $0\text{ V} < V_{IN} < 3.6\text{ V}$ , all other inputs = 0V)	-10	10	$\mu\text{A}$
$I_{O(L)}$	Output leakage current (DQ is disabled, $0\text{V} < V_{OUT} < V_{CC}$ )	-10	10	$\mu\text{A}$

**Capacitance**
 $T_A = 0^\circ\text{C to } 70^\circ\text{C}; V_{DD} = 3.3\text{V} \pm 0.3\text{V}, f = 1\text{ MHz}$ 

Symbol	Parameter	Limit Values	Unit
C <sub>I1</sub>	Input Capacitance (A0 to A11, $\overline{\text{RAS}}$ , $\overline{\text{CAS}}$ , $\overline{\text{WE}}$ )	85	pF
C <sub>I2</sub>	Input Capacitance ( $\overline{\text{CS0}}$ - $\overline{\text{CS3}}$ )	30	pF
C <sub>ICL</sub>	Input Capacitance (CLK0-CLK3)	22	pF
C <sub>I3</sub>	Input Capacitance (CKE0, CKE1)	50	pF
C <sub>I4</sub>	Input Capacitance (DQM0-DQM7)	20	pF
C <sub>IO</sub>	Input/Output Capacitance (I/O1-I/O64)	20	pF
C <sub>SC</sub>	Input Capacitance (SCL, SA0-2)	8	pF
C <sub>SD</sub>	Input/Output Capacitance	18	pF

**Absolute Maximum Ratings**

Parameter	Max.	Units
Voltage on VDD Supply Relative to V <sub>SS</sub>	-1 to 4.6	V
Voltage on Input Relative to V <sub>SS</sub>	-1 to 4.6	V
Operating Temperature	0 to +70	°C
Storage Temperature	-55 to 125	°C
Power Dissipation	7	W

**Standby and Refresh Currents<sup>1</sup>**
 $T_A = 0^{\circ}\text{C to } 70^{\circ}\text{C}, V_{CC} = 3.3\text{V} \pm 0.3\text{V}$ 

Symbol	Parameter	Test Conditions	32M x 72	Unit	Note	
$I_{CC1}$	Operating Current	Burst length = 4, CL = 3 $t_{RC} > t_{RC}(\text{min})$ , $t_{CK} > t_{CK}(\text{min})$ , IO = 0 mA 2 Bank Interleave Operation	2070	mA	1,2	
$I_{CC2P}$	Precharged Standby Current in Power Down Mode	$\text{CKE} < = V_{IL}(\text{max})$ , $t_{CK} > = t_{CK}(\text{min})$	18	mA		
$I_{CC2N}$	Precharged Standby Current in Non-Power Down Mode	$\text{CKE} > = V_{IH}(\text{min})$ , $t_{CK} > = t_{CK}(\text{min})$ , Input changed once in 3 cycles	360	mA	$\overline{\text{CS}} = \text{High}$	
$I_{CC3P}$	Active Standby Current in Power Down Mode	$\text{CKE} < = V_{IL}(\text{max})$ , $t_{CK} > = t_{CK}(\text{min})$	90	mA		
$I_{CC3N}$	Active Standby Current in Non-Power Down Mode	$\text{CKE} > = V_{IH}(\text{min})$ , $t_{CK} > = t_{CK}(\text{min})$ , Input changed one time	450	mA	$\overline{\text{CS}} = \text{High}$	
$I_{CC4}$	Burst Operating Current	$t_{RC} = \text{Infinite}$ , CL = 3, $t_{CK} > = t_{CK}(\text{min})$ , IO = 0 mA 2 Banks Activated	1530	mA	1, 2	
$I_{CC5}$	Auto Refresh Current	$t_{RC} > = t_{RC}(\text{min})$	2160	mA	1,2	
$I_{CC6}$	Self Refresh Current	CKE = <0,2 V	Standard	27	mA	1,2
			L-version	13.5		

**AC Characteristics** <sup>3,4</sup>

$T_A = 0^\circ$  to  $70^\circ\text{C}$ ;  $V_{SS} = 0\text{V}$ ;  $V_{CC} = 3.3\text{V} \pm 0.3\text{V}$ ,  $t_T = 1\text{ ns}$

#	Symbol	Parameter	Limit Values		Unit	Note
			-75PC			
			Min.	Max.		
<b>Clock and Clock Enable</b>						
1	$t_{CK}$	Clock Cycle Time $\overline{\text{CAS}}$ Latency = 3 $\overline{\text{CAS}}$ Latency = 2	7.5 7.5		ns ns	
2	$f_{CK}$	System frequency $\overline{\text{CAS}}$ Latency = 3 $\overline{\text{CAS}}$ Latency = 2	– –	133 133	MHz MHz	
3	$t_{AC}$	Clock Access Time $\overline{\text{CAS}}$ Latency = 3 $\overline{\text{CAS}}$ Latency = 2	– –	5.4 6	ns ns	4,5
4	$t_{CH}$	Clock High Pulse Width	2.5	–	ns	6
5	$t_{CL}$	Clock Low Pulse Width	2.5	–	ns	6
6	$t_{CS}$	Input Setup time	1.5	–	ns	7
7	$t_{CH}$	Input Hold Time	0.8	–	ns	7
8	$t_{CKSP}$	CKE Setup Time (Power down mode)	2.5	–	ns	8
9	$t_{CKSR}$	CKE Setup Time (Self Refresh Exit)	8	–	ns	9
10	$t_T$	Transition time (rise and fall)	1	–	ns	
<b>Common Parameters</b>						
11	$t_{RCD}$	$\overline{\text{RAS}}$ to $\overline{\text{CAS}}$ delay	15	–	ns	
12	$t_{RC}$	Cycle Time	60	120k	ns	
13	$t_{RAS}$	Active Command Period	42	–	ns	
14	$t_{RP}$	Precharge Time	20	–	ns	
15	$t_{RRD}$	Bank to Bank Delay Time	16	–	ns	
16	$t_{CCD}$	$\overline{\text{CAS}}$ to $\overline{\text{CAS}}$ delay time (same bank)	1	–	CLK	
<b>Refresh Cycle</b>						
17	$t_{SREX}$	Self Refresh Exit Time	10	–	ns	9
18	$t_{REF}$	Refresh Period (8192 cycles)	64	–	ms	8
<b>Read Cycle</b>						
19	$t_{OH}$	Data Out Hold Time	3	–	ns	4
20	$t_{LZ}$	Data Out to Low Impedance Time	0	–	ns	
21	$t_{HZ}$	Data Out to High Impedance Time	3	7.5	ns	10
22	$t_{DQZ}$	DQM Data Out Disable Latency	2	–	CLK	
<b>Write Cycle</b>						
23	$t_{DPL}$	Data input to Precharge (write recovery)	2	–	CLK	
24	$t_{DAL}$	Data In to Active/refresh	5	–	CLK	11
25	$t_{DQW}$	DQM Write Mask Latency	0	–	CLK	



**Notes:**

1. The specified values are valid when addresses are changed no more than once during  $t_{CK}(\text{min.})$  and when No Operation commands are registered on every rising clock edge during  $t_{RC}(\text{min.})$ . Values are shown per module bank.
2. The specified values are valid when data inputs (DQ's) are stable during  $t_{RC}(\text{min.})$ .
3. All AC characteristics are shown for device level.  
An initial pause of 100  $\mu\text{s}$  is required after power-up, then a Precharge All Banks command must be given followed by 8 Auto Refresh (CBR) cycles before the Mode Register Set Operation can begin.
4. AC timing tests have  $V_{IL} = 0.4\text{V}$  and  $V_{IH} = 2.4\text{V}$  with the timing referenced to the 1.4V crossover point. The transition time is measured between  $V_{IH}$  and  $V_{IL}$ . All AC measurements assume  $t_T = 1 \text{ ns}$  with the AC output load circuit shown. Specific  $t_{ac}$  and  $t_{oh}$  parameters are measured with a 50 pF only, without any resistive termination and with a input signal of 1V / ns edge rate between 0.8V and 2.0V.

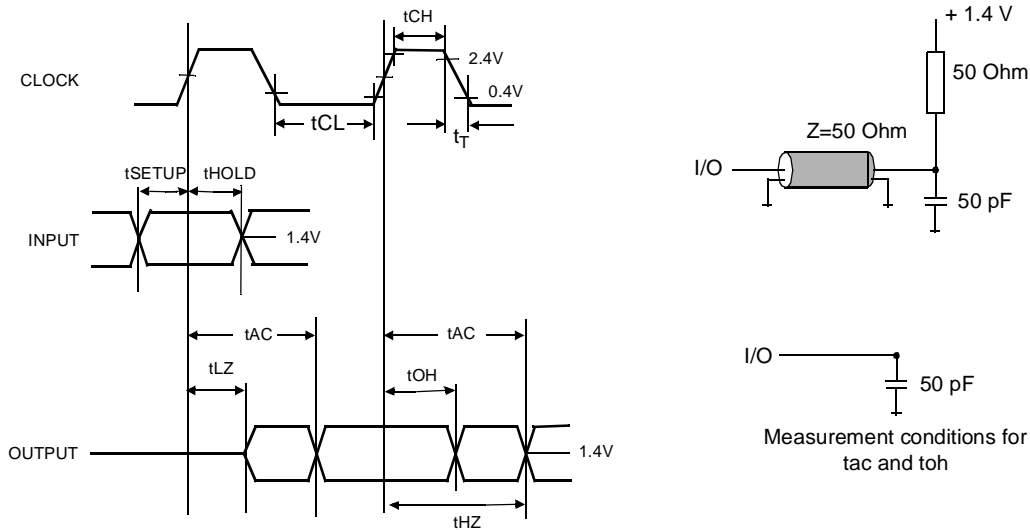

5. If clock rising time is longer than 1 ns, a time  $(t_T/2 - 0.5)$  ns has to be added to this parameter.
6. Rated at 1.5V
7. If  $t_T$  is longer than 1 ns, a time  $(t_T - 1)$  ns has to be added to this parameter.
8. Any time that the refresh Period has been exceeded, a minimum of two Auto (CBR) Refresh commands must be given to "wake-up" the device.
9. Self Refresh Exit is a synchronous operation and begins on the 2nd positive clock edge after CKE returns high. Self Refresh Exit is not complete until a time period equal to  $t_{RC}$  is satisfied once the Self Refresh Exit command is registered.
10. Referenced to the time which the output achieves the open circuit condition, not to output voltage levels.
11.  $t_{DAL}$  is equivalent to  $t_{DPL} + t_{RP}$ .

**Package Diagram**

**L-DIM-168-30**

**SDRAM DIMM Module Package**

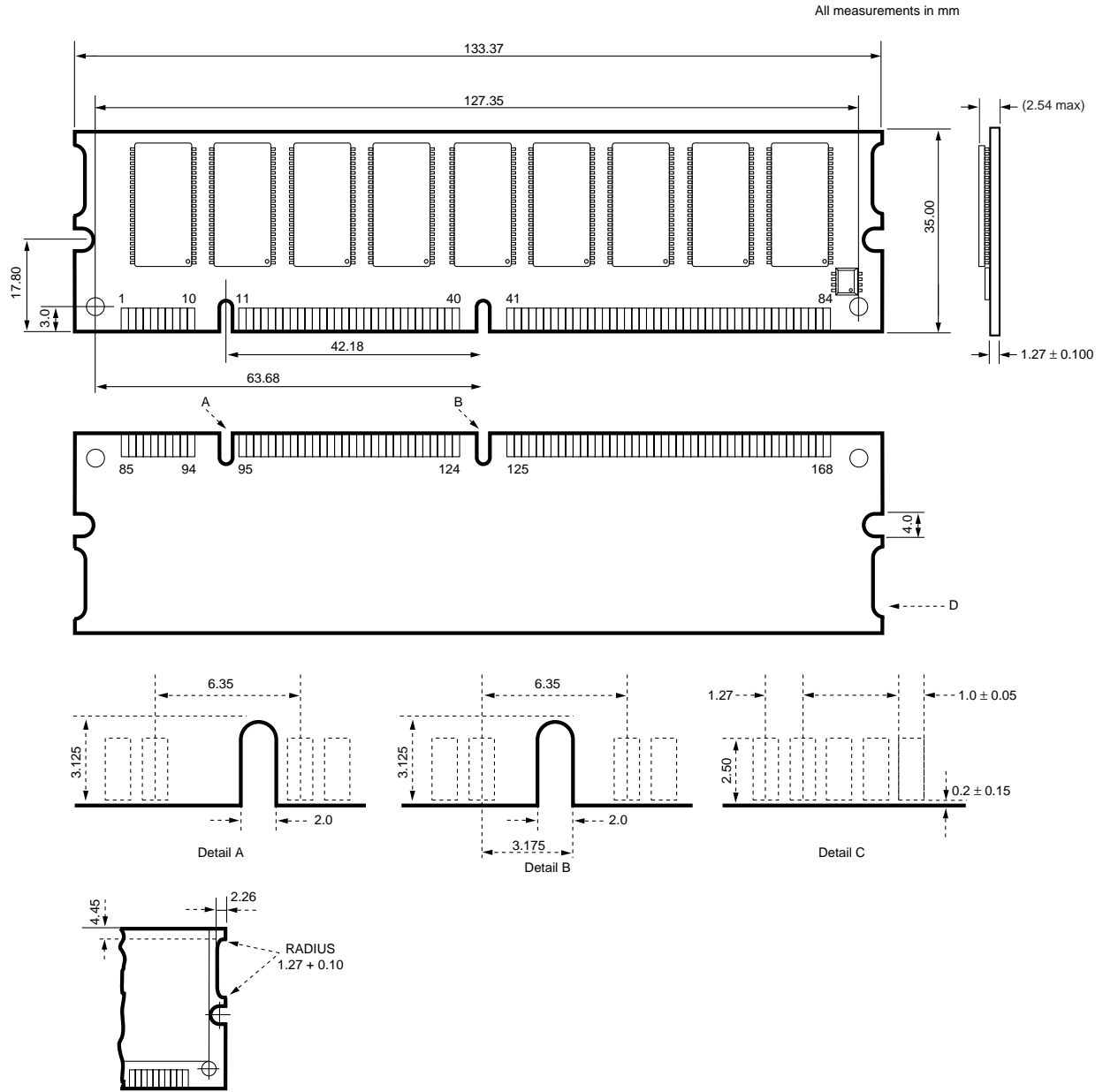

**Label Information**

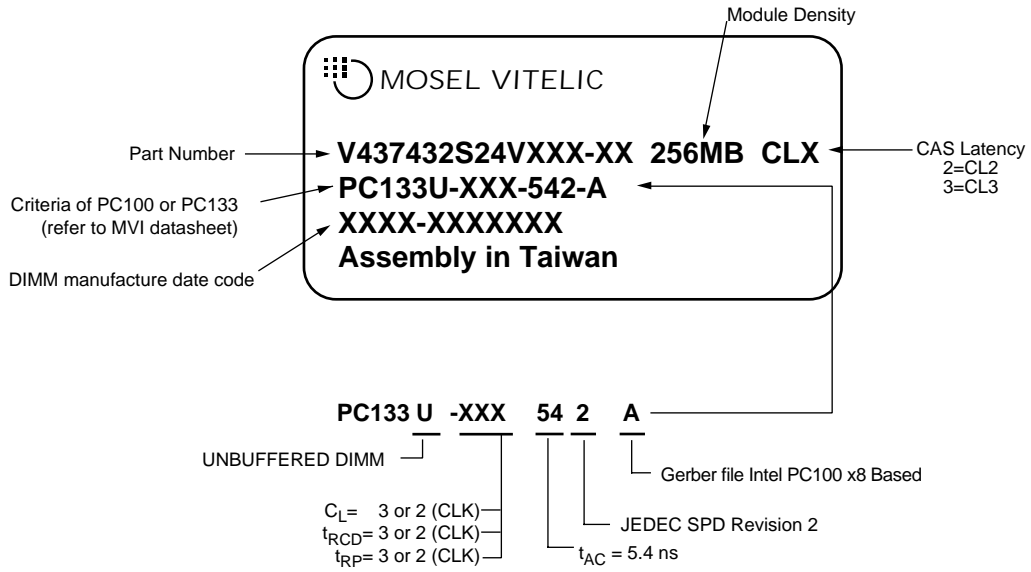

**WORLDWIDE OFFICES****U.S.A.**

3910 NORTH FIRST STREET  
SAN JOSE, CA 95134  
PHONE: 408-433-6000  
FAX: 408-433-0952

**TAIWAN**

7F, NO. 102  
MIN-CHUAN E. ROAD, SEC. 3  
TAIPEI  
PHONE: 886-2-2545-1213  
FAX: 886-2-2545-1209

NO 19 LI HSIN ROAD  
SCIENCE BASED IND. PARK  
HSIN CHU, TAIWAN, R.O.C.  
PHONE: 886-3-579-5888  
FAX: 886-3-566-5888

**SINGAPORE**

10 ANSON ROAD #23-13  
INTERNATIONAL PLAZA  
SINGAPORE 079903  
PHONE: 65-3231801  
FAX: 65-3237013

**JAPAN**

ONZE 1852 BUILDING 6F  
2-14-6 SHINTOMI, CHUO-KU  
TOKYO 104-0041  
PHONE: 03-3537-1400  
FAX: 03-3537-1402

**UK & IRELAND**

SUITE 50, GROVEWOOD  
BUSINESS CENTRE  
STRATHCLYDE BUSINESS  
PARK  
BELLSHILL, LANARKSHIRE,  
SCOTLAND, ML4 3NQ  
PHONE: 44-1698-748515  
FAX: 44-1698-748516

**GERMANY  
(CONTINENTAL  
EUROPE & ISRAEL)**

BENZSTRASSE 32  
71083 HERRENBERG  
GERMANY  
PHONE: +49 7032 2796-0  
FAX: +49 7032 2796 22

**U.S. SALES OFFICES****WEST**

3910 NORTH FIRST STREET  
SAN JOSE, CA 95134  
PHONE: 408-433-6000  
FAX: 408-433-0952

**CENTRAL / EAST**

604 FIELDWOOD CIRCLE  
RICHARDSON, TX 75081  
PHONE: 214-352-3775  
FAX: 214-904-9029

---

The information in this document is subject to change without notice.

MOSEL VITELIC makes no commitment to update or keep current the information contained in this document. No part of this document may be copied or reproduced in any form or by any means without the prior written consent of MOSEL-VITELIC.

MOSEL VITELIC subjects its products to normal quality control sampling techniques which are intended to provide an assurance of high quality products suitable for usual commercial applications. MOSEL VITELIC does not do testing appropriate to provide 100% product quality assurance and does not assume any liability for consequential or incidental arising from any use of its products. If such products are to be used in applications in which personal injury might occur from failure, purchaser must do its own quality assurance testing appropriate to such applications.