

## TFT LCD Approval Specification

# MODEL NO.: V460H1 - L05

Customer: _____  Approved by: _____  Note:
--

Approved By	TVHD	
	LY Chen	

Reviewed By	QA Dept.	Product Development Div.
	Tomy Chen	WT Lin

Prepared By	LCD TV Marketing and Product Management Div.	
	WY Li	Jim Ho

## CONTENTS -

REVISION HISTORY	-----	3
1. GENERAL DESCRIPTION	-----	4
1.1 OVERVIEW		
1.2 FEATURES		
1.3 APPLICATION		
1.4 GENERAL SPECIFICATIONS		
1.5 MECHANICAL SPECIFICATIONS		
2. ABSOLUTE MAXIMUM RATINGS	-----	5
2.1 ABSOLUTE RATINGS OF ENVIRONMENT		
2.2 PACKAGE STORAGE		
2.3 ELECTRICAL ABSOLUTE RATINGS		
2.3.1 TFT LCD MODULE		
2.3.2 BACKLIGHT UNIT		
3. ELECTRICAL CHARACTERISTICS	-----	7
3.1 TFT LCD MODULE		
3.2 BACKLIGHT UNIT		
3.2.1 CCFL(Cold Cathode Fluorescent Lamp) CHARACTERISTICS		
3.2.2 BALANCE BOARD CHARACTERISTICS		
4. BLOCK DIAGRAM	-----	12
4.1 TFT LCD MODULE		
5. INTERFACE PIN CONNECTION	-----	13
5.1 TFT LCD MODULE		
5.2 BACKLIGHT UNIT		
5.3 BALANCE BOARD UNIT		
5.4 BLOCK DIAGRAM OF INTERFACE		
5.5 LVDS INTERFACE		
5.6 COLOR DATA INPUT ASSIGNMENT		
6. INTERFACE TIMING	-----	21
6.1 INPUT SIGNAL TIMING SPECIFICATIONS		
6.2 POWER ON/OFF SEQUENCE		
7. OPTICAL CHARACTERISTICS	-----	24
7.1 TEST CONDITIONS		
7.2 OPTICAL SPECIFICATIONS		
8. DEFINITION OF LABELS	-----	28
8.1 CMO MODULE LABEL		
9. PACKAGING	-----	29
9.1 PACKING SPECIFICATIONS		
9.2 PACKING METHOD		
10. PRECAUTIONS	-----	31
10.1 ASSEMBLY AND HANDLING PRECAUTIONS		
10.2 SAFETY PRECAUTIONS		
10.3 SAFETY STANDARDS		
11. MECHANICAL CHARACTERISTICS	-----	32

**REVISION HISTORY**

Version	Date	Page (New)	Section	Description
Ver 2.0	Jul. 11,'08	All	All	Approval Specification was first issued.

## 1. GENERAL DESCRIPTION

### 1.1 OVERVIEW

V460H1-L05 is a 46" TFT Liquid Crystal Display module with 24-CCFL Backlight unit and 2ch-LVDS interface. This module supports 1920 x 1080 HDTV format and can display true 16.7M colors (8-bit/color).

The inverter module for backlight is built-in.

### 1.2 FEATURES

- High brightness (500nits)
- High contrast ratio (4000:1)
- Fast response time (Gray to Gray average 6.5 ms)
- High color saturation (72% NTSC)
- Full HDTV (1920 x 1080 pixels) resolution, true HDTV format
- DE (Data Enable) only mode
- LVDS (Low Voltage Differential Signaling) interface
- Optimized response time for 50/60 Hz frame rate
- Ultra wide viewing angle: Super MVA technology

### 1.3 APPLICATION

- Standard Living Room TVs.
- Public Display Application.
- Home Theater Application.
- MFM Application.

### 1.4 GENERAL SPECIFICATIONS

Item	Specification	Unit	Note
Active Area	1018.08(H) x 572.67(V) (46" diagonal)	mm	(1)
Bezel Opening Area	1024.4(H) x 578.6(V)	mm	
Driver Element	a-si TFT active matrix	-	-
Pixel Number	1920x R.G.B. x 1080	pixel	-
Pixel Pitch(Sub Pixel)	0.17675(H) x 0.53025(V)	mm	-
Pixel Arrangement	RGB vertical stripe	-	-
Display Colors	16.7M	color	-
Display Operation Mode	Transmissive mode / Normally black	-	-
Surface Treatment	Anti-Glare coating (Haze 17%) Hardness (3H)	-	(2)

Note (1) Please refer to the attached drawings in chapter 9 for more information about the front and back outlines.

Note (2) The spec of the surface treatment is temporarily for this phase. CMO reserves the rights to change this feature.

### 1.5 MECHANICAL SPECIFICATIONS

Item	Min.	Typ.	Max.	Unit	Note
Module Size	Horizontal (H)	-	1083	mm	(1), (2)
	Vertical (V)	-	627	mm	
	Depth (D)	-	50.6	mm	
Weight	-	15000	-	g	-

Note (1) Please refer to the attached drawings for more information of front and back outline dimensions.

Note (2) Module Depth does not include connectors.

## 2. ABSOLUTE MAXIMUM RATINGS

### 2.1 ABSOLUTE RATINGS OF ENVIRONMENT

Item	Symbol	Value		Unit	Note
		Min.	Max.		
Storage Temperature	$T_{ST}$	-20	+60	°C	(1)
Operating Ambient Temperature	$T_{OP}$	0	50	°C	(1), (2)
Shock (Non-Operating)	$S_{NOP}$	X, Y axis	50	G	(3), (5)
		Z axis	35	G	(3), (5)
Vibration (Non-Operating)	$V_{NOP}$	-	1.0	G	(4), (5)

Note (1) Temperature and relative humidity range is shown in the figure below.

- (a) 90 %RH Max. ( $T_a \leq 40$  °C).
- (b) Wet-bulb temperature should be 39 °C Max. ( $T_a > 40$  °C).
- (c) No condensation.

Note (2) The maximum operating temperature is based on the test condition that the surface temperature of display area is less than or equal to 65 °C with LCD module alone in a temperature controlled chamber. Thermal management should be considered in your product design to prevent the surface temperature of display area from being over 65 °C. The range of operating temperature may degrade in case of improper thermal management in your product design.

Note (3) 11 ms, half sine wave, 1 time for  $\pm X$ ,  $\pm Y$ , and  $\pm Z$ .

Note (4) 10 ~ 200 Hz, 10 min, 1 time each X, Y, Z.

Note (5) At testing Vibration and Shock, the fixture in holding the module has to be hard and rigid enough so that the module would not be twisted or bent by the fixture. The module would not be twisted or bent by the fixture.

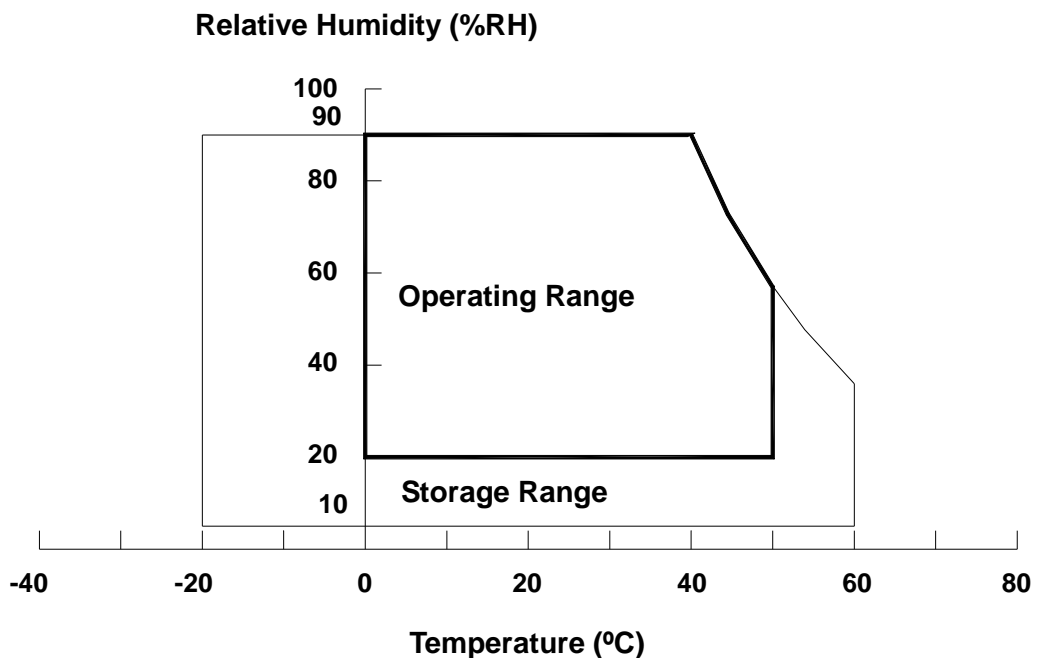

## 2.2 ELECTRICAL ABSOLUTE RATINGS

### 2.2.1 TFT LCD MODULE

Item	Symbol	Value		Unit	Note
		Min.	Max.		
Power Supply Voltage	$V_{CC}$	-0.3	13.5	V	(1)
Logic Input Voltage	$V_{IN}$	-0.3	3.6	V	

### 2.2.2 BACKLIGHT INVERTER UNIT

Item	Symbol	Value		Unit	Note
		Min.	Max.		
Lamp Voltage	$V_W$	—	3000	$V_{RMS}$	

Note (1) Permanent damage to the device may occur if maximum values are exceeded. Function operation should be restricted to the conditions described under Normal Operating Conditions.

### 3. ELECTRICAL CHARACTERISTICS

#### 3.1 TFT LCD MODULE (Ta = 25 ± 2 °C)

Parameter		Symbol	Value			Unit	Note
			Min.	Typ.	Max.		
Power Supply Voltage		V <sub>CC</sub>	10.8	12	13.2	V	(1)
Rush Current		I <sub>RUSH</sub>	-	-	4.5	A	(2)
Power Supply Current	White	I <sub>CC</sub>	-	1.3	2.0	A	(3)
	Black		-	0.6	-	A	
	Vertical Stripe		-	1.1	-	A	
LVDS Interface	Differential Input High Threshold Voltage	V <sub>LVTH</sub>	-	-	+100	mV	
	Differential Input Low Threshold Voltage	V <sub>LVTL</sub>	-100	-	-	mV	
	Common Input Voltage	V <sub>LVC</sub>	1.125	1.25	1.375	V	
	Terminating Resistor	R <sub>T</sub>	-	100	-	ohm	
CMOS interface	Input High Threshold Voltage	V <sub>IH</sub>	2.7	-	3.3	V	
	Input Low Threshold Voltage	V <sub>IL</sub>	0	-	0.7	V	

Note (1) The module should be always operated within the above ranges.

Note (2) Measurement condition:

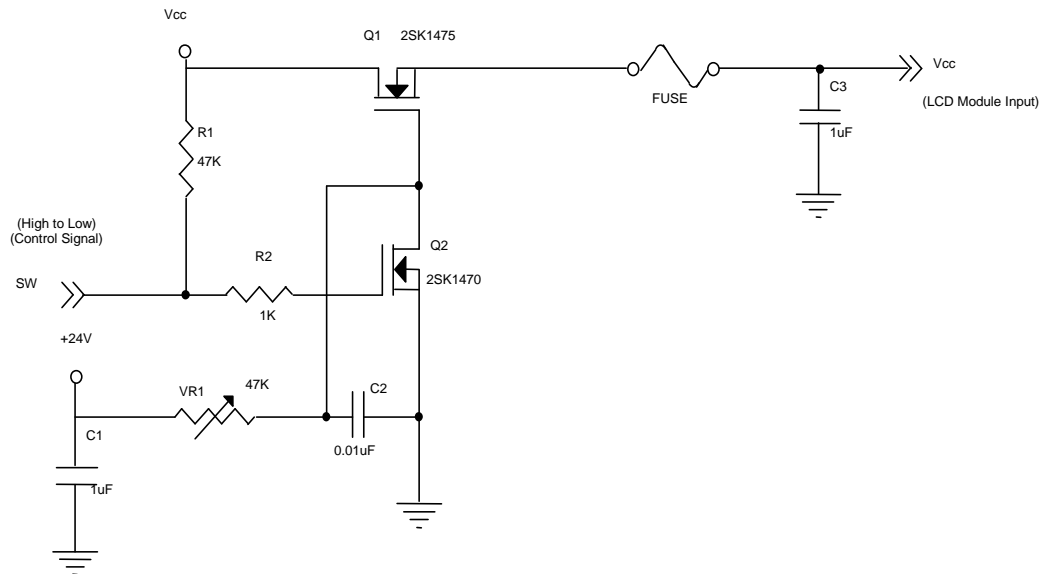

**Vcc rising time is 470us**

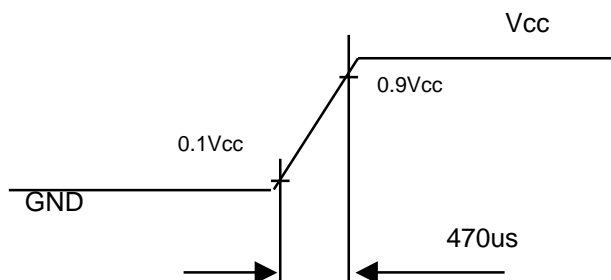

Note (3) The specified power supply current is under the conditions at  $V_{cc} = 12V$ ,  $T_a = 25 \pm 2 \text{ }^\circ\text{C}$ ,  $f_v = 60 \text{ Hz}$ , whereas a power dissipation check pattern below is displayed.

a. White Pattern

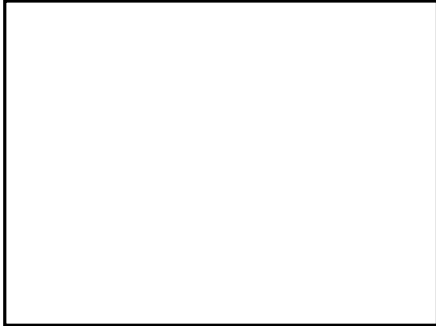

Active Area

b. Black Pattern

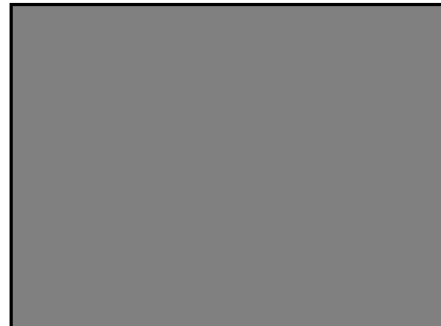

Active Area

c. Vertical Stripe Pattern

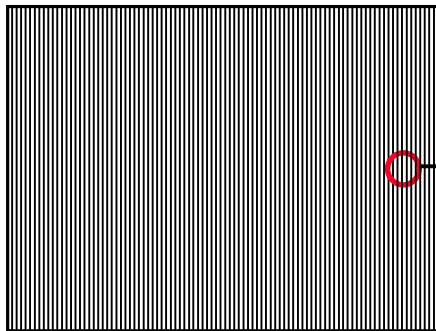

Active Area

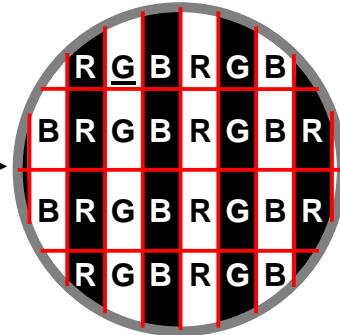



### 3.2 BACKLIGHT UNIT

#### 3.2.1 CCFL (Cold Cathode Fluorescent Lamp) CHARACTERISTICS (Ta = 25 ± 2 °C)

Parameter	Symbol	Value			Unit	Note
		Min.	Typ.	Max.		
Lamp Input Voltage	V <sub>L</sub>	-	1500	-	V <sub>RMS</sub>	-
Lamp Current	I <sub>L</sub>	5.7	6.0	6.3	mA <sub>RMS</sub>	(1)
Lamp Turn On Voltage	V <sub>S</sub>	-	-	2360	V <sub>RMS</sub>	(2), Ta = 0 °C
		-	-	2220	V <sub>RMS</sub>	(2), Ta = 25 °C
Operating Frequency	F <sub>L</sub>	40	-	80	KHz	(3)
Lamp Life Time	L <sub>BL</sub>	50,000	-	-	Hrs	(4)

Note (1) Lamp current is measured by utilizing AC current probe and its value is average by measuring master and slave board.:

Note (2) The lamp starting voltage V<sub>S</sub> should be applied to the lamp for more than 1 second after startup. Otherwise the lamp may not be turned on.

Note (3) The lamp frequency may produce interference with horizontal synchronous frequency of the display input signals, and it may result in line flow on the display. In order to avoid interference, the lamp frequency should be detached from the horizontal synchronous frequency and its harmonics as far as possible.

Note (4) The life time of a lamp is defined as when the brightness is larger than 50% of its original value and the effective discharge length is longer than 80% of its original length (Effective discharge length is defined as an area that has equal to or more than 70% brightness compared to the brightness at the center point of lamp.) as the time in which it continues to operate under the condition at Ta = 25 ± 2°C and I<sub>L</sub> = 5.7~6.3 mA<sub>RMS</sub>.

#### 3.2.2 BALANCE BOARD CHARACTERISTICS (Ta = 25 ± 2 °C)

Parameter	Symbol	Value			Unit	Note
		Min.	Typ.	Max.		
Input High Voltage	V <sub>HV</sub>	-	1590	-	V	(6)
Protection Circuit Supply Voltage	V <sub>CC</sub>	10	12	15	v	
Input Current	I <sub>BL(HV)</sub>		300		mA <sub>RMS</sub>	No Dimming
Oscillating Frequency	F <sub>W</sub>	45	48	51	kHz	
Individual Lamp Current	I <sub>L</sub>	5.7	6.0	6.3	mA	H.V (5)
Lamp Detection	High (LD)	LD	5		V	Normal Operation
	Low (LD)	LD		1.5	V	Lamp Connector Open
Dimming frequency	F <sub>B</sub>	135	150	165	Hz	
Minimum Duty Ratio	D <sub>MIN</sub>	-	15	-	%	

Note (5) Lamp current is measured master board by utilizing high frequency current meters as shown below:

Note (6) Input voltage Hv based on spec. +-7% tolerance.

Note (7) Asymmetric ratio must be from 90% to 110% ( $0.9 < I_p / I_{rms@T/2X\sqrt{2}} < 1.1$ )

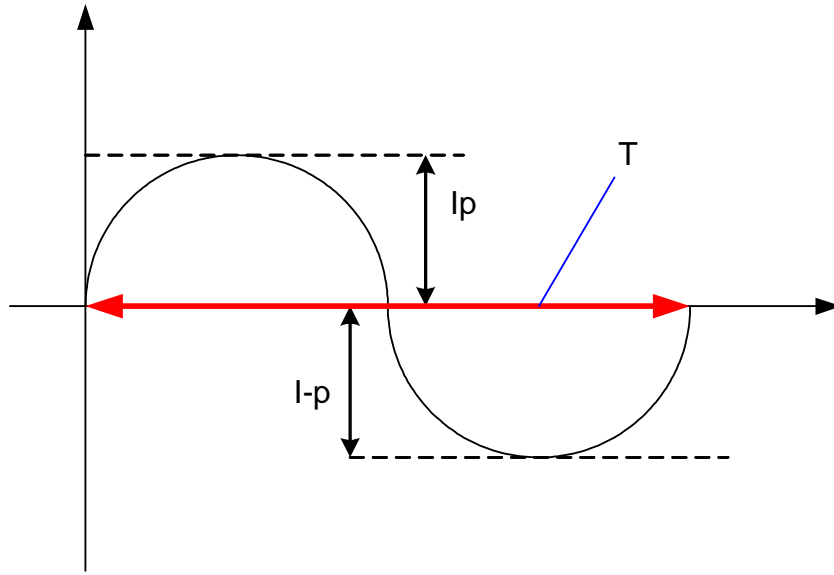

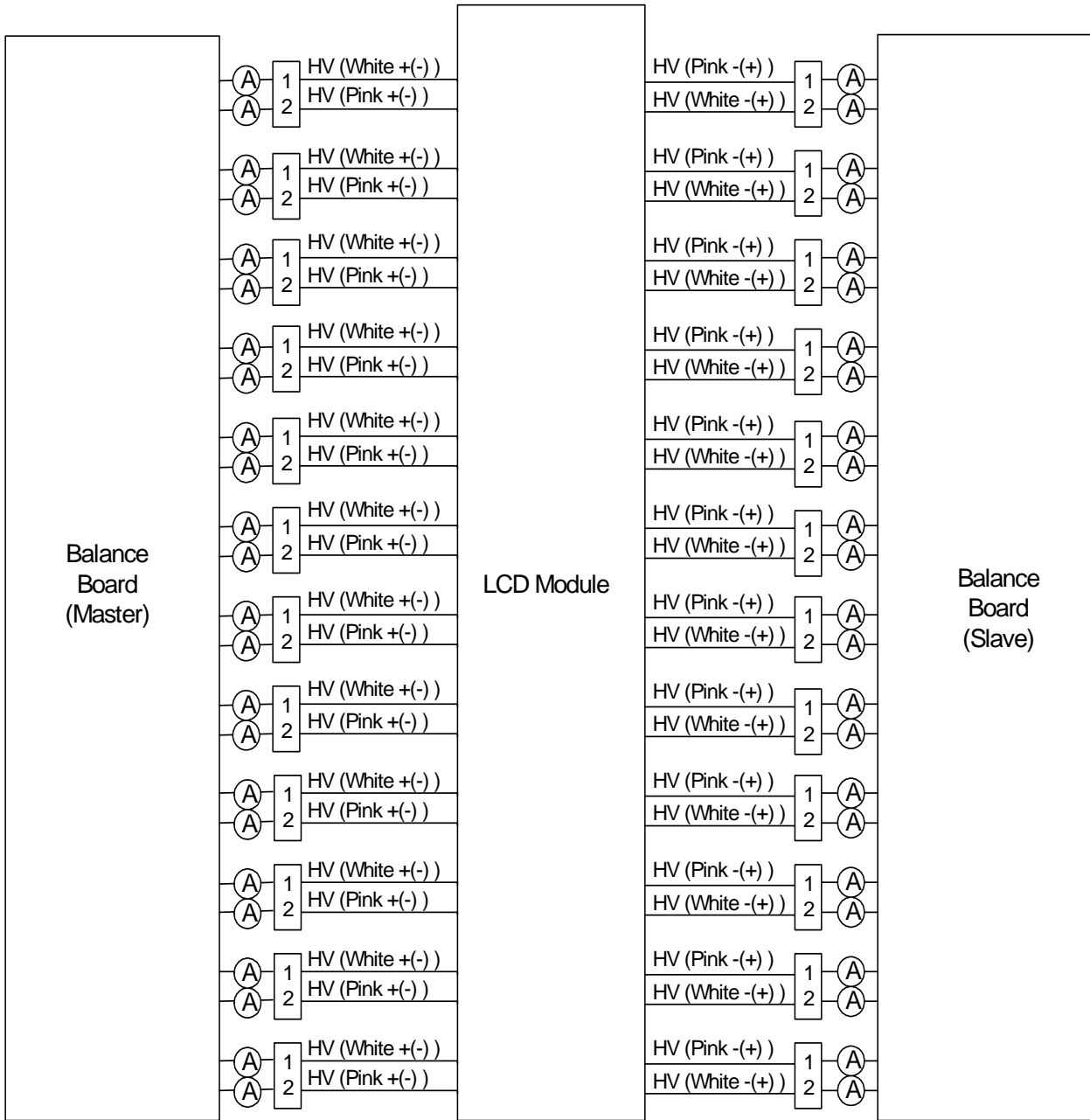

**4. BLOCK DIAGRAM OF INTERFACE**

**4.1 TFT LCD MODULE**

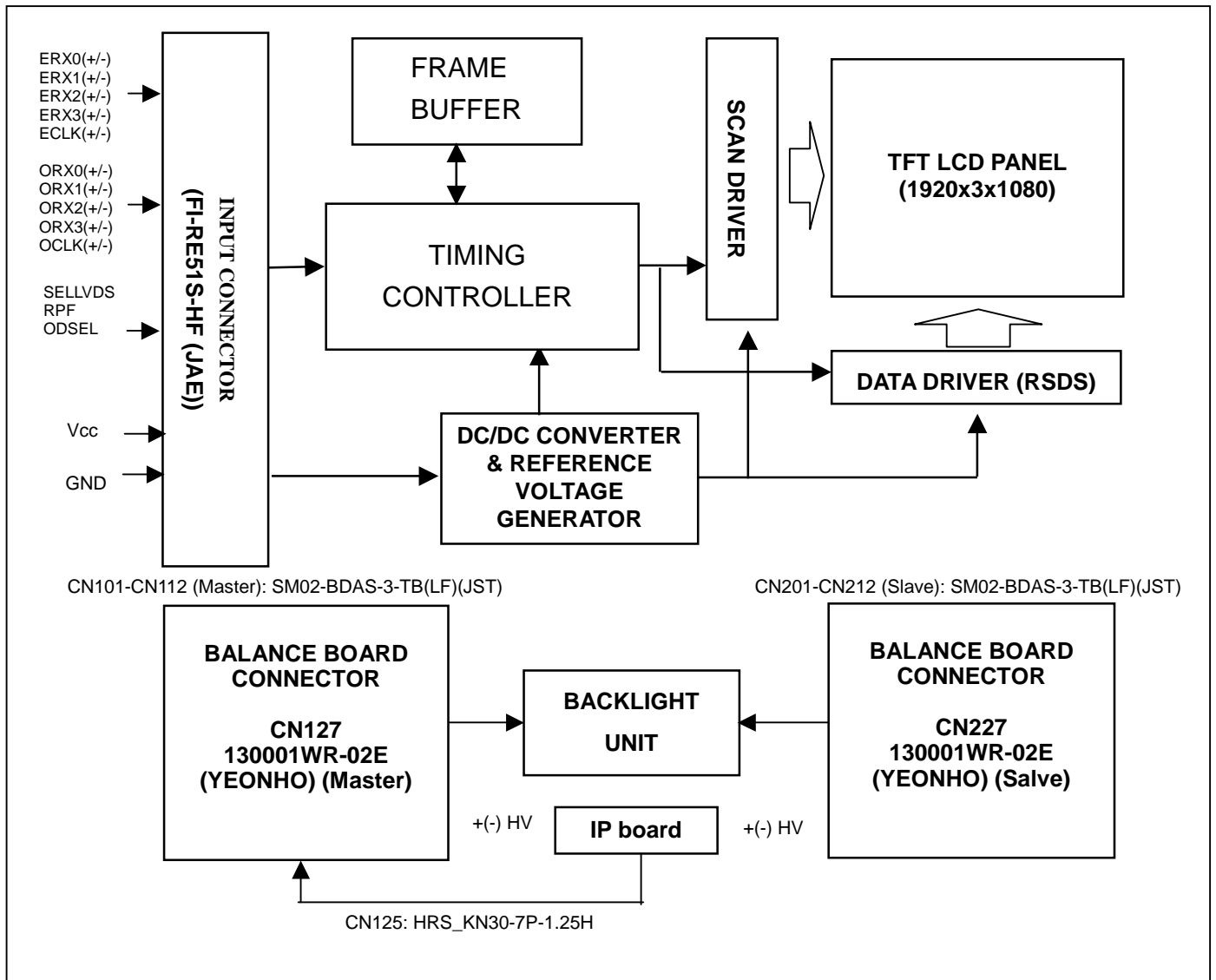

## 5 .INPUT TERMINAL PIN ASSIGNMENT

### 5.1 TFT LCD Module

Pin	Name	Description	Note
1	VCC	+12V power supply	
2	VCC	+12V power supply	
3	VCC	+12V power supply	
4	VCC	+12V power supply	
5	VCC	+12V power supply	
6	GND	Ground	
7	GND	Ground	
8	GND	Ground	
9	GND	Ground	
10	ORX0-	Odd pixel Negative LVDS differential data input. Channel 0	
11	ORX0+	Odd pixel Positive LVDS differential data input. Channel 0	
12	ORX1-	Odd pixel Negative LVDS differential data input. Channel 1	
13	ORX1+	Odd pixel Positive LVDS differential data input. Channel 1	
14	ORX2-	Odd pixel Negative LVDS differential data input. Channel 2	
15	ORX2+	Odd pixel Positive LVDS differential data input. Channel 2	
16	GND	Ground	
17	OCLK-	Odd pixel Negative LVDS differential clock input.	
18	OCLK+	Odd pixel Positive LVDS differential clock input.	
19	GND	Ground	
20	ORX3-	Odd pixel Negative LVDS differential data input. Channel 3	
21	ORX3+	Odd pixel Positive LVDS differential data input. Channel 3	
22	N.C.	No Connection	(1)
23	N.C.	No Connection	
24	GND	Ground	
25	ERX0-	Even pixel, Negative LVDS differential data input. Channel 0	
26	ERX0+	Even pixel, Positive LVDS differential data input. Channel 0	
27	ERX1-	Even pixel, Negative LVDS differential data input. Channel 1	
28	ERX1+	Even pixel, Positive LVDS differential data input. Channel 1	
29	ERX2-	Even pixel, Negative LVDS differential data input. Channel 2	
30	ERX2+	Even pixel, Positive LVDS differential data input. Channel 2	
31	GND	Ground	
32	ECLK-	Even pixel, Negative LVDS differential clock input	
33	ECLK+	Even pixel, Positive LVDS differential clock input.	
34	GND	Ground	
35	ERX3-	Even pixel, Negative LVDS differential data input. Channel 3	
36	ERX3+	Even pixel, Positive LVDS differential data input. Channel 3	
37	N.C.	No Connection	(1)
38	N.C.	No Connection	
39	GND	Ground	
40	ODSEL	Overdrive Lookup Table Selection	(3)
41	N.C.	No Connection	(1)
42	N.C.	No Connection	(1)
43	N.C.	No Connection	
44	N.C.	No Connection	(1)
45	SELLVDS	LVDS Data Format Selection	(2)
46	N.C.	No Connection	(1)
47	N.C.	No Connection	
48	N.C.	No Connection	

49	N.C.	No Connection	(1)
50	N.C.	No Connection	
51	N.C.	No Connection	

Note (1) Reserved for internal use. Please leave it open.

Note (2) Low : JEIDA LVDS Format (default), High : VESA Format.

Note (3) Overdrive lookup table selection. The overdrive lookup table should be selected in accordance with the frame rate to optimize image quality.

ODSEL	Note
L	Lookup table was optimized for 60 Hz frame rate
H	Lookup table was optimized for 50 Hz frame rate.

Note (4) Low =Open or Connect to GND, High = Connect to +3.3V

### 5.2 BACKLIGHT UNIT

The pin configuration for the housing and the leader wire is shown in the table below.

CN3-CN26: BDAMR-02VAS-3 (JST).

Pin	Name	Description	Wire Color
1	HV	High Voltage	Pink
2	HV	High Voltage	White

Note (1) The backlight interface housing for high voltage side is a model BDAMR-02VAS-3, manufactured by JST. The mating header on inverter part number is SM02-BDAS-3-TB (LF)(JST)

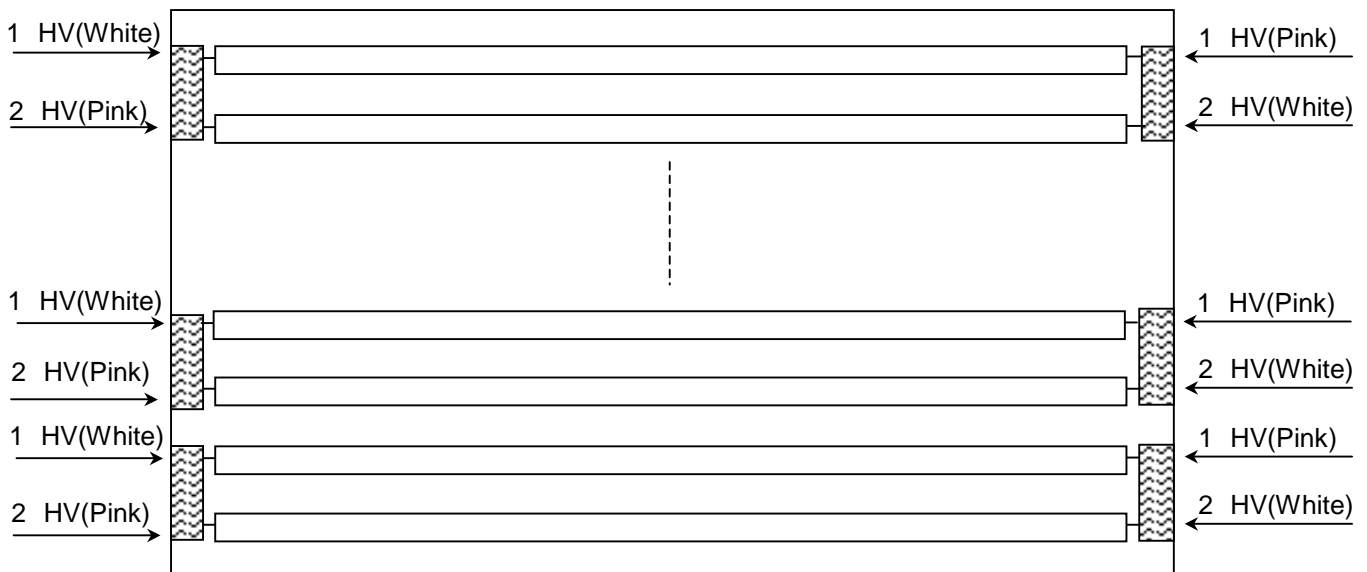

### 5.3 BALANCE BOARD UNIT

CN127 (Header) (Master): 130001WR-02E (YEONHO)

Pin No.	Symbol	Description
1	HV	High Voltage
2	HV	High Voltage

CN227 (Header) (Slave): 130001WR-02E (YEONHO)

Pin No.	Symbol	Description
1	HV	High Voltage
2	HV	High Voltage

CN101-CN112 (Header) (Master): SM02-BDAS-3-TB (LF)(JST)

Pin No.	Symbol	Description
1	HV+(-)	CCFL high voltage
2	HV+(-)	CCFL high voltage

CN201-CN212 (Header) (Slave): SM02-BDAS-3-TB (LF)(JST)

Pin No.	Symbol	Description
1	HV+(-)	CCFL high voltage
2	HV+(-)	CCFL high voltage

CN125 (Header): KN30-7P-1.25H (Hirose).

Pin No.	Symbol	Description
1	VCC	Power Supply for Protection Circuit
2	FB	Lamp Current Detected Voltage
3	FB	Lamp Current Detected Voltage
4	GND	Signal Ground
5	GND	Signal Ground
6	LD	CCFL Connector Open & Non-lighting signal
7	LD	CCFL Connector Open & Non-lighting signal



**5.4 BLOCK DIAGRAM OF INTERFACE**

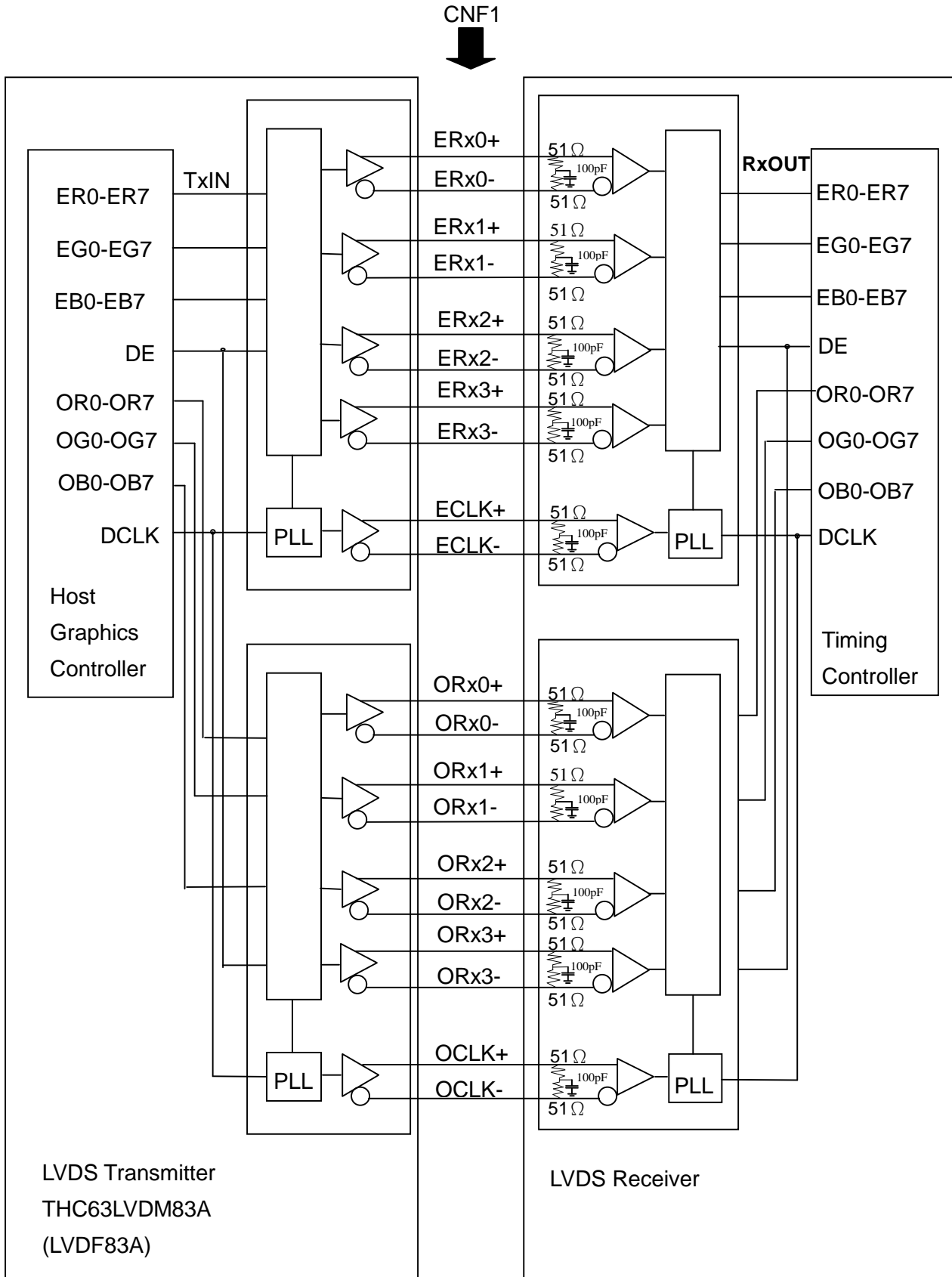

ER0~ER7 : Even pixel R data

EG0~EG7 : Even pixel G data

EB0~EB7 : Even pixel B data

OR0~OR7 : Odd pixel R data

OG0~OG7 : Odd pixel G data

OB0~OB7 : Odd pixel B data

DE : Data enable signal

DCLK : Data clock signal

Notes:

- (1) The system must have the transmitter to drive the module.
- (2) LVDS cable impedance shall be 50 ohms per signal line or about 100 ohms per twist-pair line when it is used differentially.
- (3) Two pixel data send into the module for every clock cycle. The first pixel of the frame is odd pixel and the second pixel is even pixel.

### 5.5 LVDS INTERFACE

	SIGNAL		TRANSMITTER THC63LVDM83A		INTERFACE CONNECTOR		RECEIVER THC63LVDF84A		TFT CONTROL INPUT	
	LVDS_SEL =H	LVDS_SEL = L or OPEN	PIN	INPUT	Host	TFT-LCD	PIN	OUTPUT	LVDS_SEL =H	LVDS_SEL = L or OPEN
24bit	R0	R2	51	TxIN0	TA OUT0+	Rx 0+	27	Rx OUT0	R0	R2
	R1	R3	52	TxIN1			29	Rx OUT1	R1	R3
	R2	R4	54	TxIN2			30	Rx OUT2	R2	R4
	R3	R5	55	TxIN3			32	Rx OUT3	R3	R5
	R4	R6	56	TxIN4	TA OUT0-	Rx 0-	33	Rx OUT4	R4	R6
	R5	R7	3	TxIN6			35	Rx OUT6	R5	R7
	G0	G2	4	TxIN7			37	Rx OUT7	G0	G2
	G1	G3	6	TxIN8			38	Rx OUT8	G1	G3
	G2	G4	7	TxIN9	TA OUT1+	Rx 1+	39	Rx OUT9	G2	G4
	G3	G5	11	TxIN12			43	Rx OUT12	G3	G5
	G4	G6	12	TxIN13			45	Rx OUT13	G4	G6
	G5	G7	14	TxIN14			46	Rx OUT14	G5	G7
	B0	B2	15	TxIN15	TA OUT1-	Rx 1-	47	Rx OUT15	B0	B2
	B1	B3	19	TxIN18			51	Rx OUT18	B1	B3
	B2	B4	20	TxIN19			53	Rx OUT19	B2	B4
	B3	B5	22	TxIN20			54	Rx OUT20	B3	B5
	B4	B6	23	TxIN21	TA OUT2+	Rx 2+	55	Rx OUT21	B4	B6
	B5	B7	24	TxIN22			1	Rx OUT22	B5	B7
	DE	DE	30	TxIN26			6	Rx OUT26	DE	DE
	R6	R0	50	TxIN27			TA OUT2-	Rx 2-	7	Rx OUT27
	R7	R1	2	TxIN5	34	Rx OUT5			R7	R1
	G6	G0	8	TxIN10	41	Rx OUT10			G6	G0
	G7	G1	10	TxIN11	42	Rx OUT11			G7	G1
	B6	B0	16	TxIN16	TA OUT3+	Rx 3+	49	Rx OUT16	B6	B0
	B7	B1	18	TxIN17			50	Rx OUT17	B7	B1
	RSVD 1	RSVD 1	25	TxIN23			2	Rx OUT23	NC	NC
	RSVD 2	RSVD 2	27	TxIN24			TA OUT3-	Rx 3-	3	Rx OUT24
	RSVD 3	RSVD 3	28	TxIN25	5	Rx OUT25			NC	NC
DCLK			31	TxCLK IN	TxCLK OUT+	RxCLK IN+	26	RxCLK OUT	DCLK	
					TxCLK OUT-	RxCLK IN-				

R0~R7: Pixel R Data (7; MSB, 0; LSB)

G0~G7: Pixel G Data (7; MSB, 0; LSB)

B0~B7: Pixel B Data (7; MSB, 0; LSB)

DE : Data enable signal

DCLK : Data clock signal

Notes (1) RSVD (reserved) pins on the transmitter shall be "H" or "L".

### 5.6 COLOR DATA INPUT ASSIGNMENT

The brightness of each primary color (red, green and blue) is based on the 8-bit gray scale data input for the color. The higher the binary input, the brighter the color. The table below provides the assignment of the color versus data input.

Color		Data Signal																						
		Red								Green								Blue						
		R7	R6	R5	R4	R3	R2	R1	R0	G7	G6	G5	G4	G3	G2	G1	G0	B7	B6	B5	B4	B3	B2	B1
Basic Colors	Black	0	0	0	0	0	0	0	0	0	0	0	0	0	0	0	0	0	0	0	0	0	0	0
	Red	1	1	1	1	1	1	1	1	0	0	0	0	0	0	0	0	0	0	0	0	0	0	0
	Green	0	0	0	0	0	0	0	0	1	1	1	1	1	1	1	1	0	0	0	0	0	0	0
	Blue	0	0	0	0	0	0	0	0	0	0	0	0	0	0	0	0	1	1	1	1	1	1	1
	Cyan	0	0	0	0	0	0	0	0	1	1	1	1	1	1	1	1	1	1	1	1	1	1	1
	Magenta	1	1	1	1	1	1	1	1	0	0	0	0	0	0	0	0	1	1	1	1	1	1	1
	Yellow	1	1	1	1	1	1	1	1	1	1	1	1	1	1	1	1	0	0	0	0	0	0	0
	White	1	1	1	1	1	1	1	1	1	1	1	1	1	1	1	1	1	1	1	1	1	1	1
Gray Scale Of Red	Red (0) / Dark	0	0	0	0	0	0	0	0	0	0	0	0	0	0	0	0	0	0	0	0	0	0	
	Red (1)	0	0	0	0	0	0	0	1	0	0	0	0	0	0	0	0	0	0	0	0	0	0	
	Red (2)	0	0	0	0	0	0	1	0	0	0	0	0	0	0	0	0	0	0	0	0	0	0	
	⋮	⋮	⋮	⋮	⋮	⋮	⋮	⋮	⋮	⋮	⋮	⋮	⋮	⋮	⋮	⋮	⋮	⋮	⋮	⋮	⋮	⋮	⋮	
	⋮	⋮	⋮	⋮	⋮	⋮	⋮	⋮	⋮	⋮	⋮	⋮	⋮	⋮	⋮	⋮	⋮	⋮	⋮	⋮	⋮	⋮	⋮	
	Red (253)	1	1	1	1	1	1	0	1	0	0	0	0	0	0	0	0	0	0	0	0	0	0	0
	Red (254)	1	1	1	1	1	1	1	0	0	0	0	0	0	0	0	0	0	0	0	0	0	0	0
Red (255)	1	1	1	1	1	1	1	1	0	0	0	0	0	0	0	0	0	0	0	0	0	0	0	
Gray Scale Of Green	Green (0) / Dark	0	0	0	0	0	0	0	0	0	0	0	0	0	0	0	0	0	0	0	0	0	0	
	Green (1)	0	0	0	0	0	0	0	0	0	0	0	0	0	0	1	0	0	0	0	0	0	0	
	Green (2)	0	0	0	0	0	0	0	0	0	0	0	0	0	1	0	0	0	0	0	0	0	0	
	⋮	⋮	⋮	⋮	⋮	⋮	⋮	⋮	⋮	⋮	⋮	⋮	⋮	⋮	⋮	⋮	⋮	⋮	⋮	⋮	⋮	⋮	⋮	
	⋮	⋮	⋮	⋮	⋮	⋮	⋮	⋮	⋮	⋮	⋮	⋮	⋮	⋮	⋮	⋮	⋮	⋮	⋮	⋮	⋮	⋮	⋮	
	Green (253)	0	0	0	0	0	0	0	0	1	1	1	1	1	1	0	1	0	0	0	0	0	0	0
	Green (254)	0	0	0	0	0	0	0	0	1	1	1	1	1	1	1	0	0	0	0	0	0	0	0
Green (255)	0	0	0	0	0	0	0	0	1	1	1	1	1	1	1	1	0	0	0	0	0	0	0	
Gray Scale Of Blue	Blue (0) / Dark	0	0	0	0	0	0	0	0	0	0	0	0	0	0	0	0	0	0	0	0	0	0	
	Blue (1)	0	0	0	0	0	0	0	0	0	0	0	0	0	0	0	0	0	0	0	0	0	1	
	Blue (2)	0	0	0	0	0	0	0	0	0	0	0	0	0	0	0	0	0	0	0	0	0	1	
	⋮	⋮	⋮	⋮	⋮	⋮	⋮	⋮	⋮	⋮	⋮	⋮	⋮	⋮	⋮	⋮	⋮	⋮	⋮	⋮	⋮	⋮	⋮	
	⋮	⋮	⋮	⋮	⋮	⋮	⋮	⋮	⋮	⋮	⋮	⋮	⋮	⋮	⋮	⋮	⋮	⋮	⋮	⋮	⋮	⋮	⋮	
	Blue (253)	0	0	0	0	0	0	0	0	0	0	0	0	0	0	0	0	1	1	1	1	1	1	0
	Blue (254)	0	0	0	0	0	0	0	0	0	0	0	0	0	0	0	0	1	1	1	1	1	1	0
Blue (255)	0	0	0	0	0	0	0	0	0	0	0	0	0	0	0	0	1	1	1	1	1	1	1	

Note (1) 0: Low Level Voltage, 1: High Level Voltage

## 6. INTERFACE TIMING

### 6.1 INPUT SIGNAL TIMING SPECIFICATIONS

The input signal timing specifications are shown as the following table and timing diagram.

Signal	Item	Symbol	Min.	Typ.	Max.	Unit	Note
LVDS Receiver Clock	Frequency	1/Tc	(60)	74	(80)	MHz	-
	Input cycle to cycle jitter	Trcl	-	-	200	ps	-
LVDS Receiver Data	Setup Time	Tlvsu	600	-	-	ps	-
	Hold Time	Tlvhd	600	-	-	ps	-
Vertical Active Display Term	Frame Rate	Fr5	47	50	53	Hz	(1)
		Fr6	57	60	63	Hz	(1)
	Total	Tv	1115	1125	1135	Th	Tv=Tvd+Tvb
	Display	Tvd	1080	1080	1080	Th	-
	Blank	Tvb	35	45	55	Th	-
Horizontal Active Display Term	Total	Th	1050	1100	1150	Tc	Th=Thd+Thb
	Display	Thd	960	960	960	Tc	-
	Blank	Thb	90	140	190	Tc	-

Note (1) (ODSEL) = (H), (L). Please refer to 5.1 for detail information.

Note (2) Since the module is operated in DE only mode, Hsync and Vsync input signals should be set to low logic level. Otherwise, this module would operate abnormally.

#### INPUT SIGNAL TIMING DIAGRAM

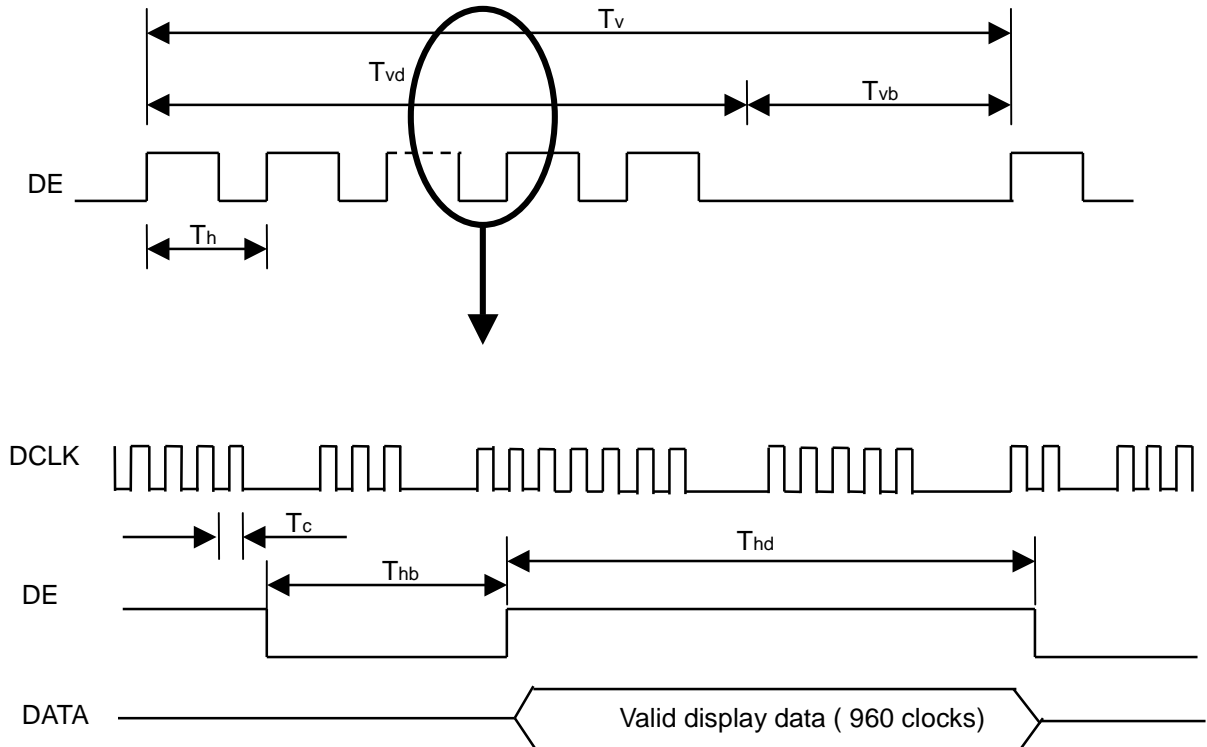

**LVDS INPUT INTERFACE TIMING DIAGRAM**

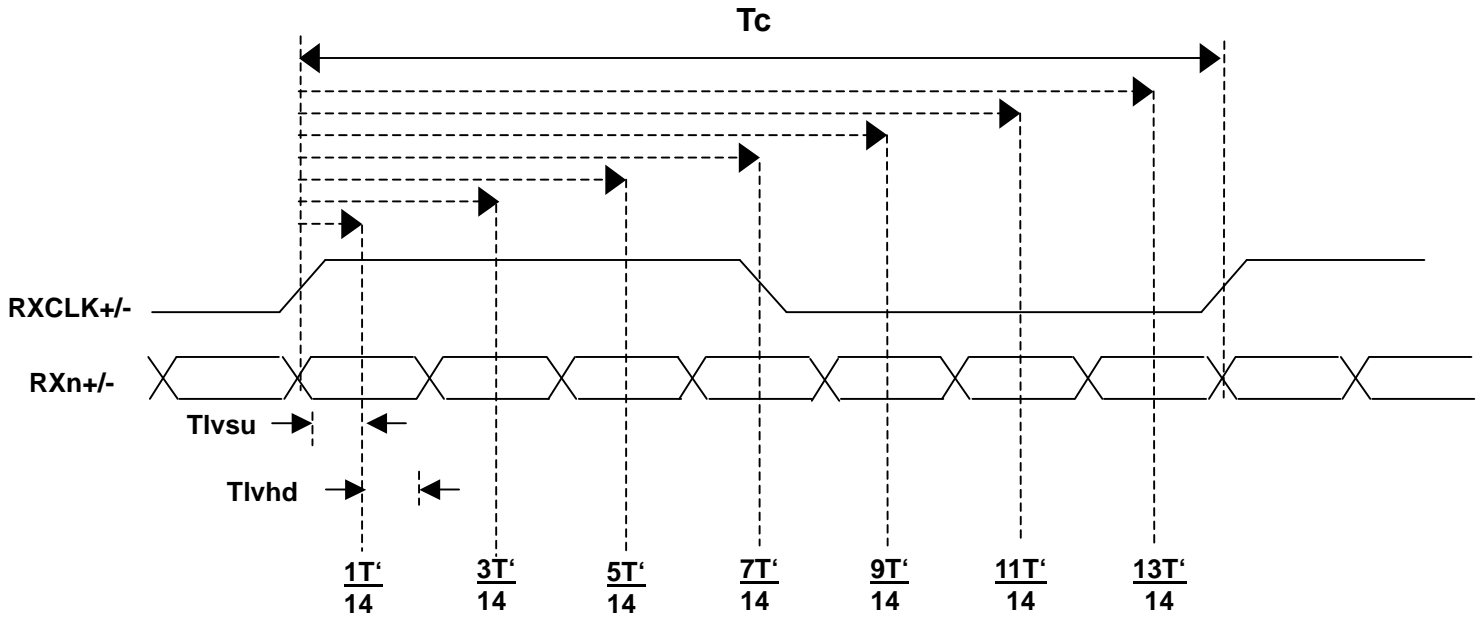

### 6.2 POWER ON/OFF SEQUENCE

To prevent a latch-up or DC operation of LCD module, the power on/off sequence should follow the diagram below.

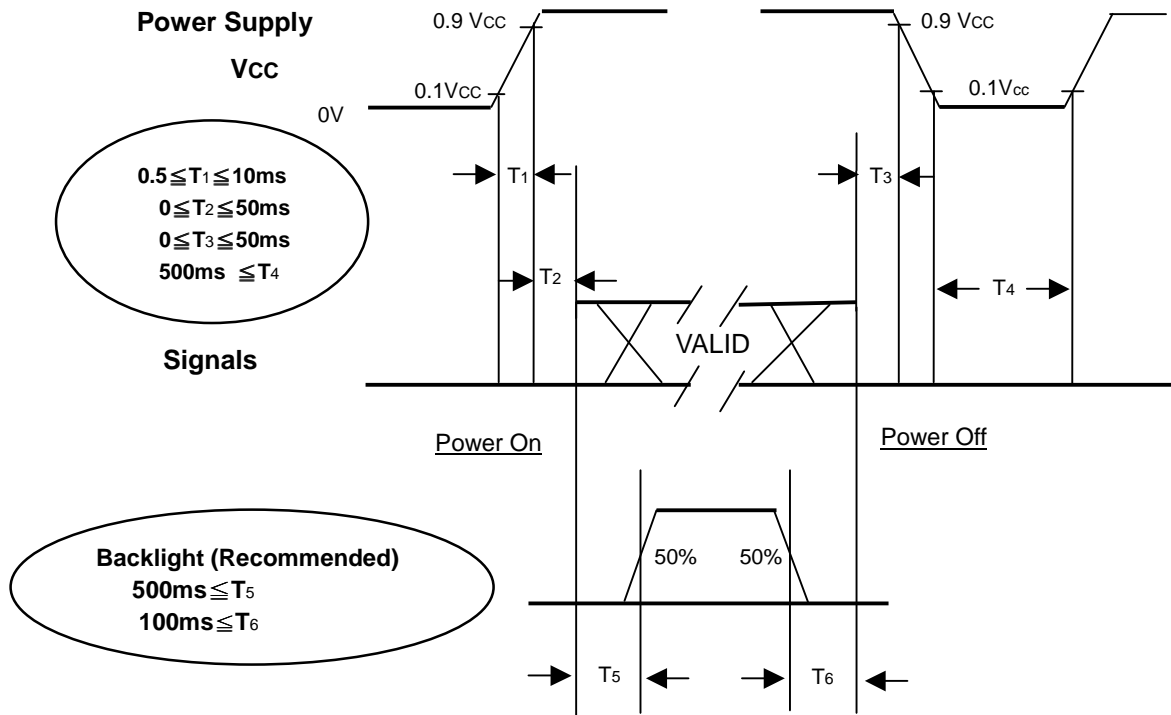

**Power ON/OFF Sequence**

Note :

- (1) The supply voltage of the external system for the module input should follow the definition of V<sub>CC</sub>.
- (2) Apply the lamp voltage within the LCD operation range. When the backlight turns on before the LCD operation or the LCD turns off before the backlight turns off, the display may momentarily become abnormal screen.
- (3) In case of V<sub>CC</sub> is in off level, please keep the level of input signals on the low or high impedance.
- (4) T<sub>4</sub> should be measured after the module has been fully discharged between power off and on period.
- (5) Interface signal shall not be kept at high impedance when the power is on.

## 7. OPTICAL CHARACTERISTICS

### 7.1 TEST CONDITIONS

Item	Symbol	Value	Unit
Ambient Temperature	Ta	25±2	°C
Ambient Humidity	Ha	50±10	%RH
Supply Voltage	V <sub>CC</sub>	12V	V
Input Signal	According to typical value in "3. ELECTRICAL CHARACTERISTICS"		
Lamp Current	I <sub>L</sub>	6.0±0.2	mA
Oscillating Frequency (Inverter)	F <sub>W</sub>	44±3	KHz
Vertical Frame Rate	Fr	60	Hz

### 7.2 OPTICAL SPECIFICATIONS

The relative measurement methods of optical characteristics are shown in 7.2. The following items should be measured under the test conditions described in 7.1 and stable environment shown in Note (6).

Item		Symbol	Condition	Min.	Typ.	Max.	Unit	Note	
Contrast Ratio		CR	$\theta_x=0^\circ, \theta_y=0^\circ$ Viewing angle at normal direction	3000	4000	-	-	Note (2)	
Response Time		Gray to gray		-	6.5	12	ms	Note (3)	
Center Luminance of White		L <sub>C</sub>		450	500	-	cd/m <sup>2</sup>	Note (4)	
White Variation		$\delta W$		-	-	1.3	-	Note (7)	
Cross Talk		CT		-	-	4	%	Note (5)	
Color Chromaticity	Red	R <sub>x</sub>		Typ.- 0.03	Typ.+ 0.03	0.643	-	-	Note (6)
		R <sub>y</sub>				0.334		-	
	Green	G <sub>x</sub>				0.266		-	
		G <sub>y</sub>				0.607		-	
	Blue	B <sub>x</sub>				0.150		-	
		B <sub>y</sub>	0.060			-			
	White	W <sub>x</sub>	0.280			-			
		W <sub>y</sub>	0.290			-			
Color Gamut				72	-	%	NTSC		
Viewing Angle	Horizontal	$\theta_{x+}$	CR≥20	80	88	-	Deg.	Note (1)	
		$\theta_{x-}$							
	Vertical	$\theta_{y+}$							
		$\theta_{y-}$							



Note (1) Definition of Viewing Angle ( $\theta_x, \theta_y$ ):

Viewing angles are measured by Eldim EZ-Contrast 160R

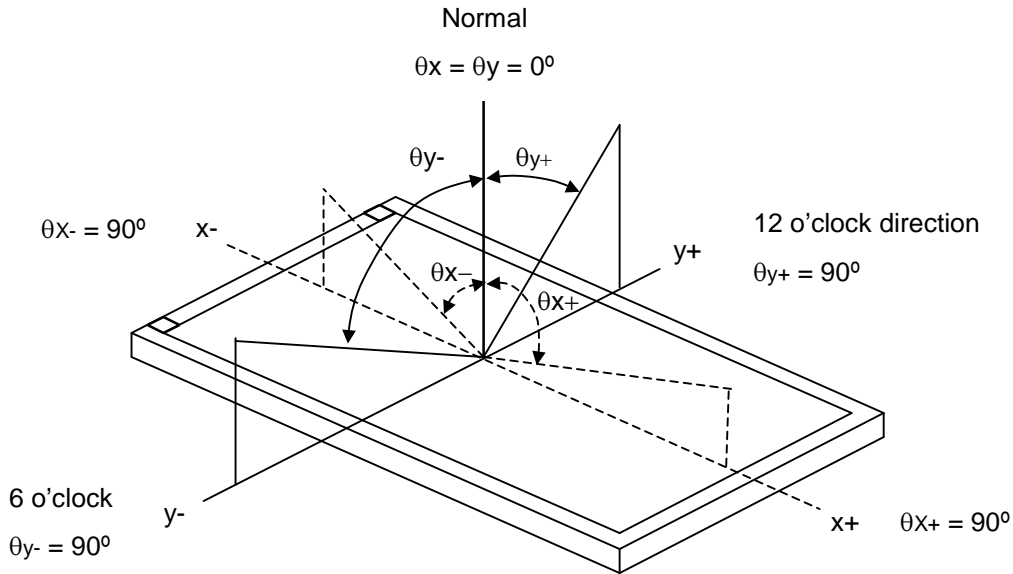

Note (2) Definition of Contrast Ratio (CR):

The contrast ratio can be calculated by the following expression.

$$\text{Contrast Ratio (CR)} = L_{255} / L_0$$

L255: Luminance of gray level 255

L 0: Luminance of gray level 0

CR = CR (X), where CR (X) is corresponding to the Contrast Ratio of the point X at the figure in Note (7)

Note (3) Definition of Gray to Gray Switching Time :

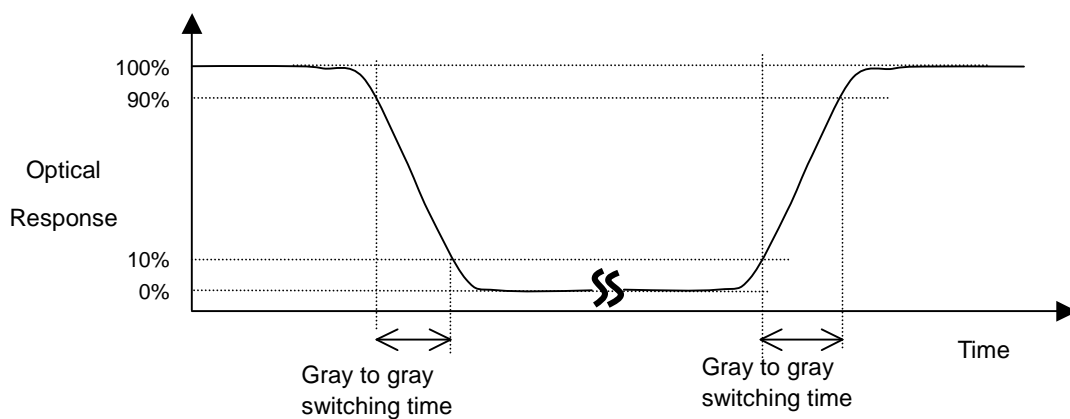

The driving signal means the signal of gray level 0, 63, 127, 191, and 255.

Gray to gray average time means the average switching time of gray level 0, 63, 127, 191, 255 to each other .

Note (4) Definition of Luminance of White ( $L_C$ ):

Measure the luminance of gray level 255 at center point.

$L_C = L(5)$ , where  $L(x)$  is corresponding to the luminance of the point X at the figure in Note (7).

Note (5) Definition of Cross Talk (CT):

$$CT = |Y_B - Y_A| / Y_A \times 100 (\%)$$

Where:

$Y_A$  = Luminance of measured location without gray level 0 pattern ( $\text{cd}/\text{m}^2$ )

$Y_B$  = Luminance of measured location with gray level 0 pattern ( $\text{cd}/\text{m}^2$ )

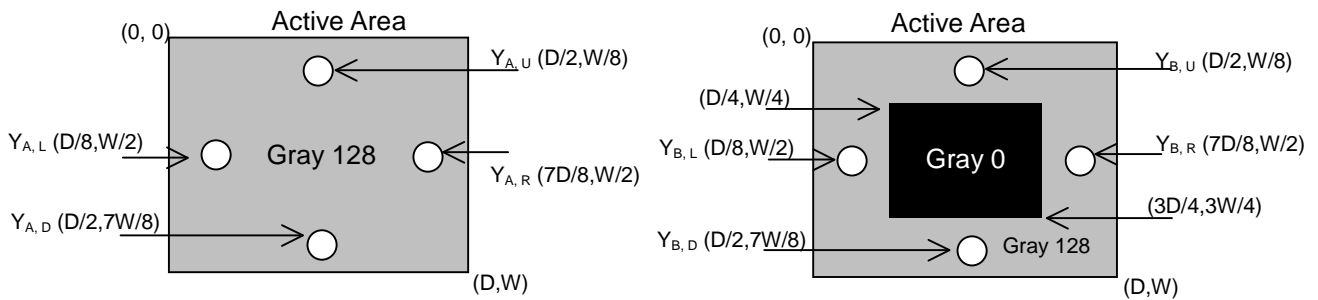

Note (6) Measurement Setup:

The LCD module should be stabilized at given temperature for 1 hour to avoid abrupt temperature change during measuring. In order to stabilize the luminance, the measurement should be executed after lighting backlight for 1 hour in a windless room.

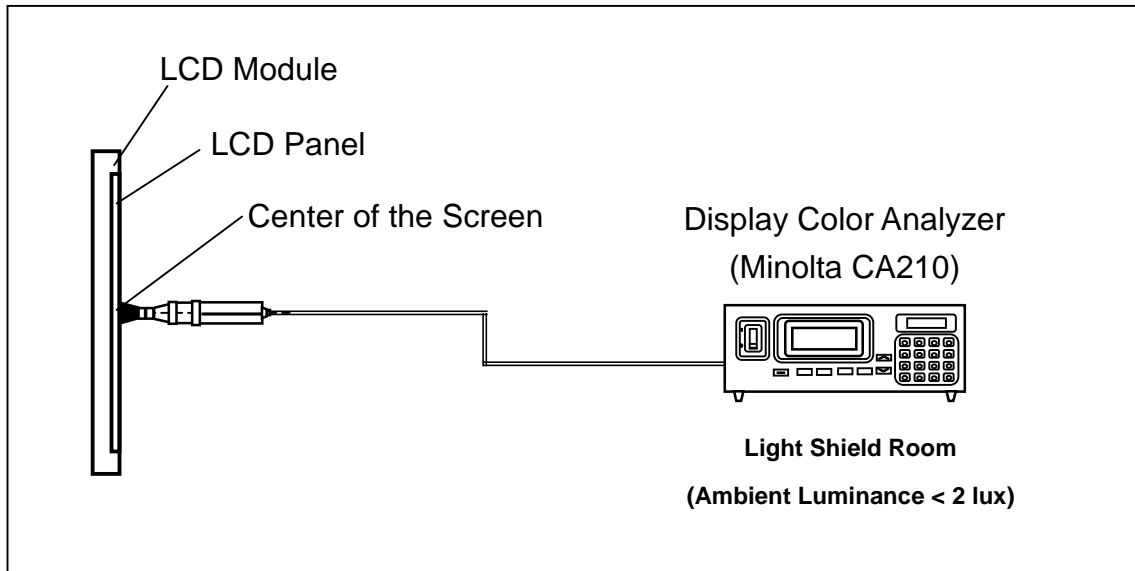

Note (7) Definition of White Variation ( $\delta W$ ):

Measure the luminance of gray level 255 at 5 points

$$\delta W = \text{Maximum} [L(1), L(2), L(3), L(4), L(5)] / \text{Minimum} [L(1), L(2), L(3), L(4), L(5)]$$

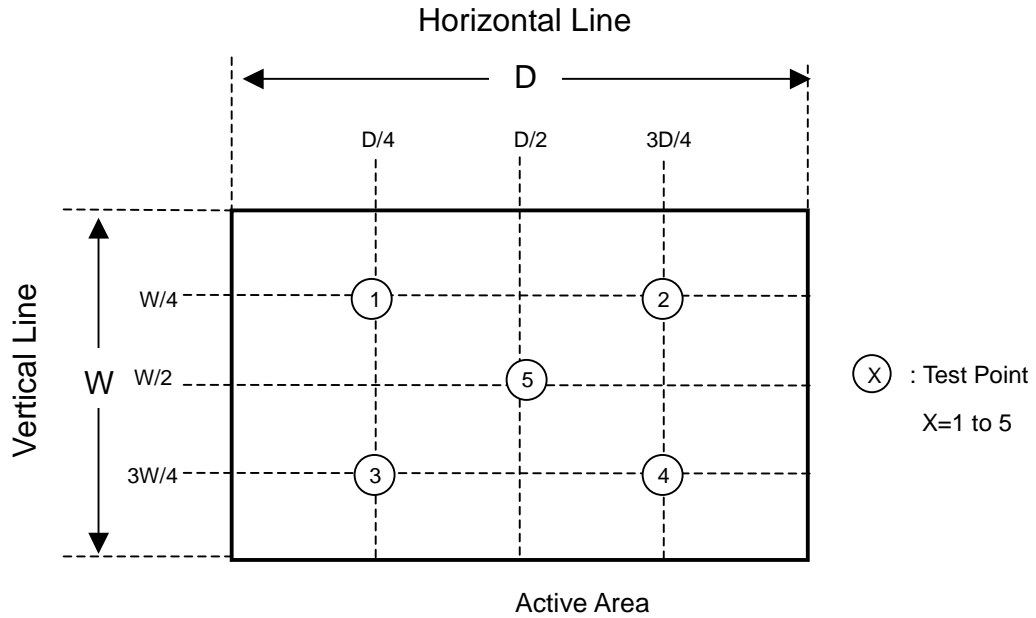

## 8. DEFINITION OF LABELS

### 8.1 CMO MODULE LABEL

The barcode nameplate is pasted on each module as illustration, and its definitions are as following explanation.

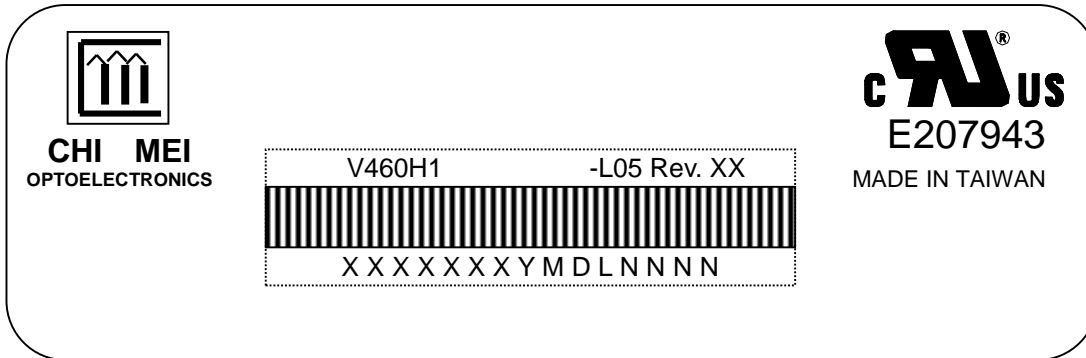

- (a) Model Name: V460H1-L05
- (b) Revision: Rev. XX, for example: A0, A1... B1, B2... or C1, C2...etc.
- (c) Serial ID: XX-XX-X-XX-YMD-L-NNNN

Code	Meaning	Description
XX	CMO internal use	-
XX	Revision	Cover all the change
X-XX	CMO internal use	-
YMD	Year, month, day	Year: 2001=1, 2002=2, 2003=3, 2004=4... Month: Jan. ~ Dec.=1, 2, 3, ~, 9, A, B, C Day: 1 <sup>st</sup> to 31 <sup>st</sup> =1, 2, 3, ~, 9, A, B, C, ~, W, X, Y, exclude I, O, and U
L	Product line #	Line 1=1, Line 2=2, Line 3=3, ...
NNNN	Serial number	Manufacturing sequence of product

## 9. PACKAGING

### 9.1 PACKING SPECIFICATIONS

- (1) 3 LCD TV modules / 1 Box
- (2) Box dimensions : 1190(L)x280(W)x712(H)mm
- (3) Weight : approximately 50Kg (3 modules per box)

### 9.2 PACKING METHOD

Figures 9-1 and 9-2 are the packing method

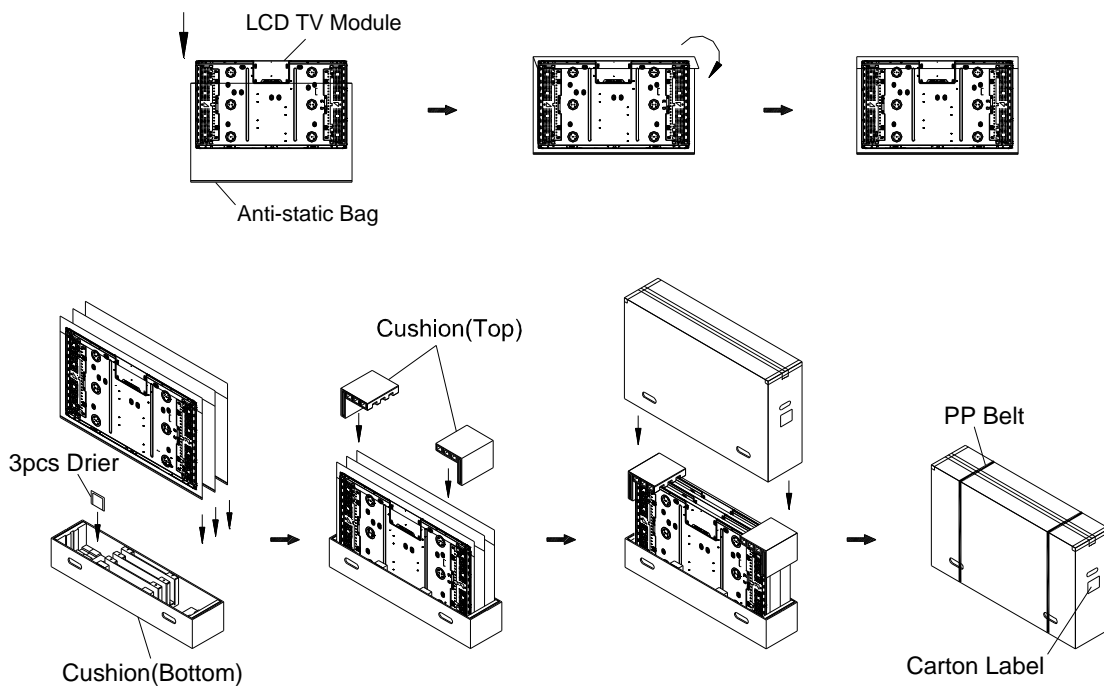
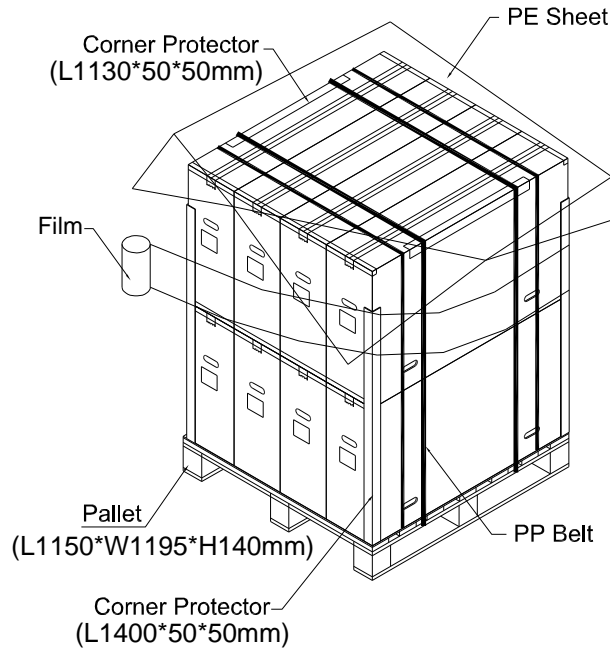

Figure.9-1 packing method

Air Transportation &  
Sea / Land Transportation (40ft Container)



Sea / Land Transportation (40ft HQ Container)

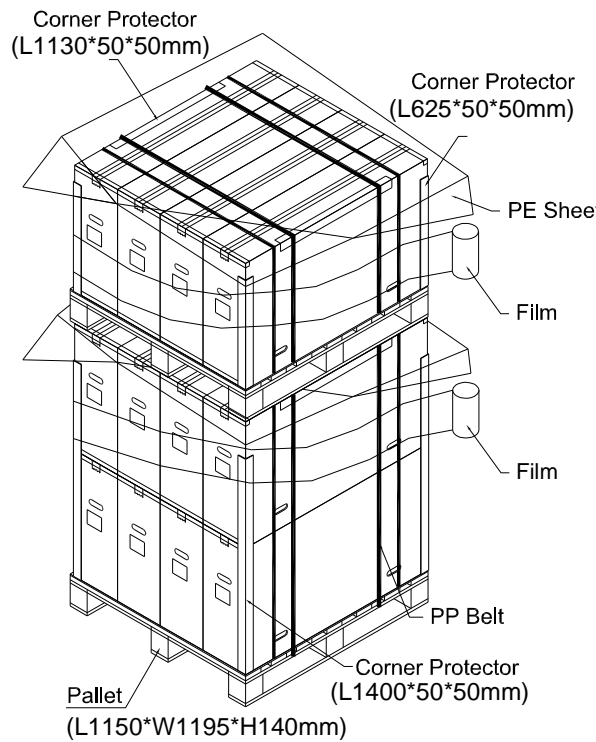

Figure.9-2 packing method

## 10. PRECAUTIONS

### 10.1 ASSEMBLY AND HANDLING PRECAUTIONS

- (1) Do not apply rough force such as bending or twisting to the module during assembly.
- (2) It is recommended to assemble or to install a module into the user's system in clean working areas. The dust and oil may cause electrical short or worsen the polarizer.
- (3) Do not apply pressure or impulse to the module to prevent the damage of LCD panel and backlight.
- (4) Always follow the correct power-on sequence when the LCD module is turned on. This can prevent the damage and latch-up of the CMOS LSI chips.
- (5) Do not plug in or pull out the I/F connector while the module is in operation.
- (6) Do not disassemble the module.
- (7) Use a soft dry cloth without chemicals for cleaning, because the surface of polarizer is very soft and easily scratched.
- (8) Moisture can easily penetrate into LCD module and may cause the damage during operation.
- (9) High temperature or humidity may deteriorate the performance of LCD module. Please store LCD modules in the specified storage conditions.
- (10) When ambient temperature is lower than 10°C, the display quality might be reduced. For example, the response time will become slow, and the starting voltage of CCFL will be higher than that of room temperature.

### 10.2 SAFETY PRECAUTIONS

- (1) The startup voltage of a backlight is over 1000 Volts. It may cause an electrical shock while assembling with the inverter. Do not disassemble the module or insert anything into the backlight unit.
- (2) If the liquid crystal material leaks from the panel, it should be kept away from the eyes or mouth. In case of contact with hands, skin or clothes, it has to be washed away thoroughly with soap.
- (3) After the module's end of life, it is not harmful in case of normal operation and storage.

### 10.3 SAFETY STANDARDS

The LCD module should be certified with safety regulations as follows:

Regulatory	Item	Standard
Information Technology equipment	UL	UL 60950-1: 2003
	cUL	CAN/CSA C22.2 No.60950-1-03
	CB	IEC 60950-1:2001
Audio/Video Apparatus	UL	UL 60065: 2003
	cUL	CAN/CSA C22.2 No.60065-03
	CB	IEC 60065:2001

### 11. MECHANICAL CHARACTERISTIC

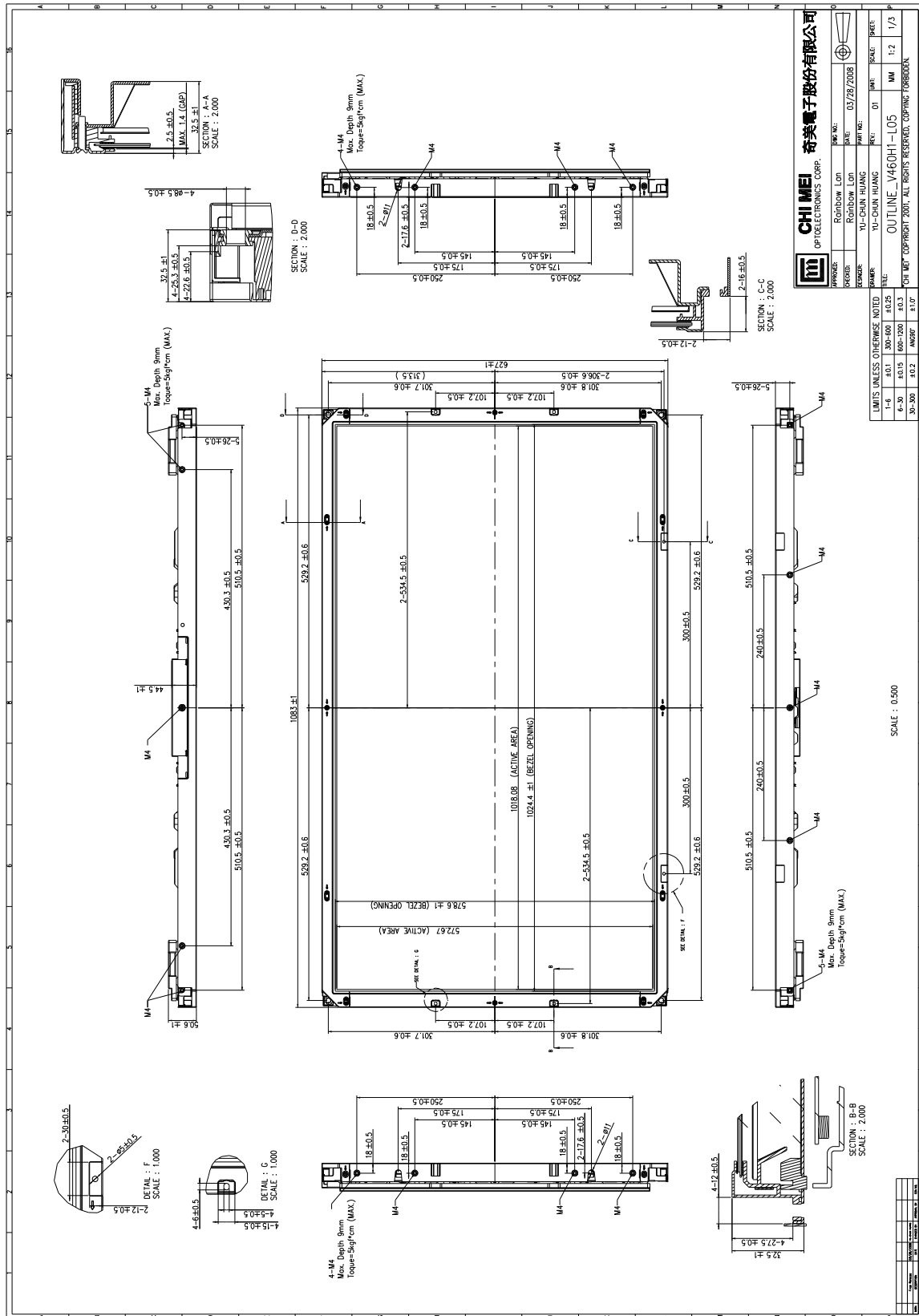



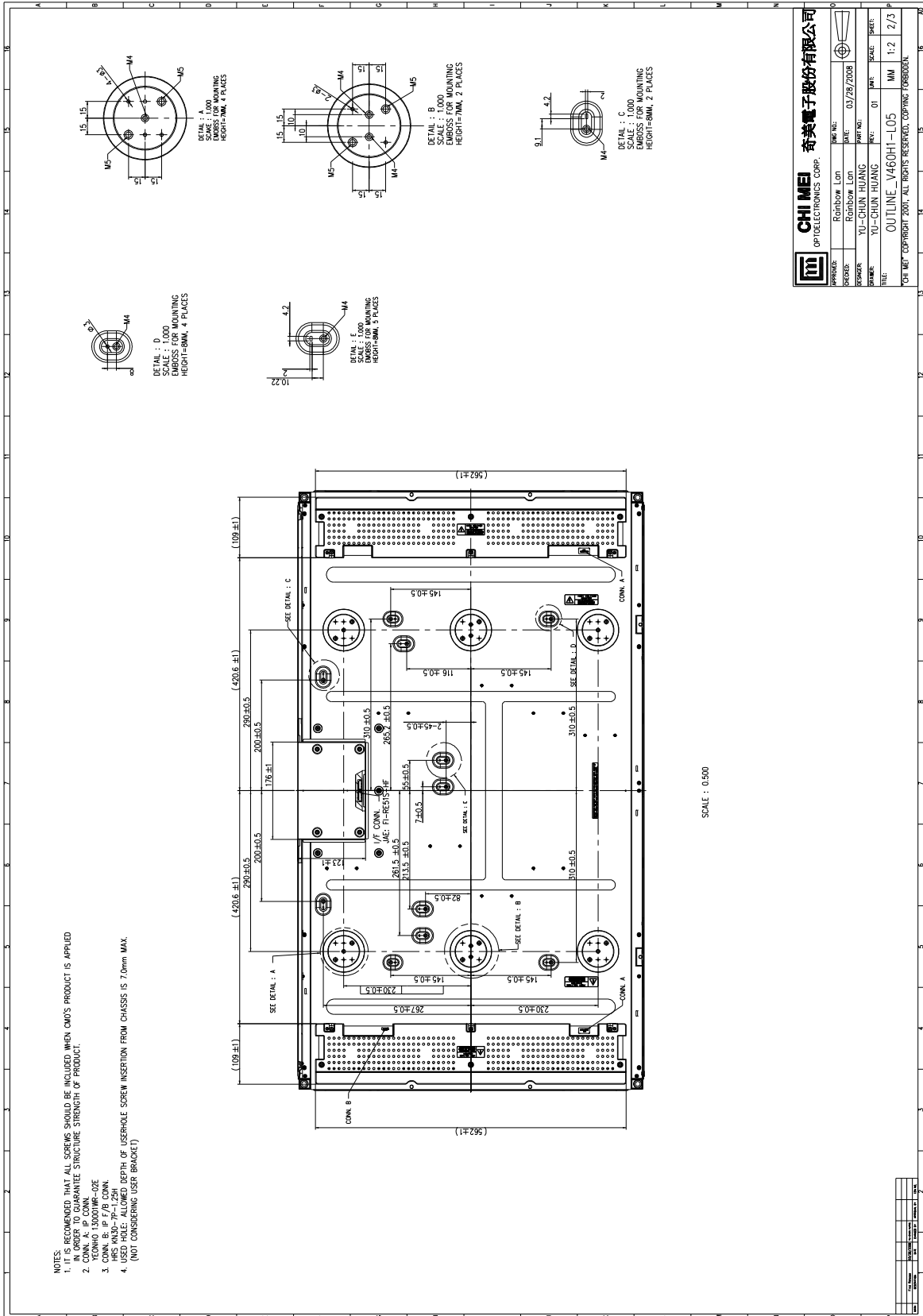

**CHI MEI**  
OPTOELECTRONICS CORP.  
奇美電子股份有限公司

DATE: 03/28/2008  
APPROVE: Rainbow Lon  
DESIGNER: YU-CHUN HUANG  
DATE: 01  
SCALE: MM 1:2 2/3  
TITLE: OUTLINE\_V460H1-L05

CHI MEI OPTOELECTRONICS CORP. ALL RIGHTS RESERVED. COPYRIGHT 2007.

