

## TFT LCD Approval Specification

# MODEL NO.: V460H1 - L07

|                    |
|--------------------|
| Customer: _____    |
| Approved by: _____ |
| Note:              |

|             |         |  |
|-------------|---------|--|
| Approved By | TVHD    |  |
|             | LY Chen |  |

|             |          |                          |
|-------------|----------|--------------------------|
| Reviewed By | QA Dept. | Product Development Div. |
|             | Kc_Ko    | WT Lin                   |

|             |  |        |
|-------------|--|--------|
| Prepared By | LCD TV Marketing and Product Management Div. |        |
|             | WY Li  | Jim Ho |

## CONTENTS -

|   |       |    |
|---|-------|----|
| REVISION HISTORY  | ----- | 3  |
| 1. GENERAL DESCRIPTION                                    | ----- | 4  |
| 1.1 OVERVIEW  |       |    |
| 1.2 FEATURES  |       |    |
| 1.3 APPLICATION   |       |    |
| 1.4 GENERAL SPECIFICATIONS                                |       |    |
| 1.5 MECHANICAL SPECIFICATIONS                             |       |    |
| 2. ABSOLUTE MAXIMUM RATINGS                               | ----- | 5  |
| 2.1 ABSOLUTE RATINGS OF ENVIRONMENT                       |       |    |
| 2.2 PACKAGE STORAGE                                       |       |    |
| 2.3 ELECTRICAL ABSOLUTE RATINGS                           |       |    |
| 2.3.1 TFT LCD MODULE                                      |       |    |
| 2.3.2 BACKLIGHT UNIT                                      |       |    |
| 3. ELECTRICAL CHARACTERISTICS                             | ----- | 7  |
| 3.1 TFT LCD MODULE  |       |    |
| 3.2 BACKLIGHT UNIT  |       |    |
| 3.2.1 CCFL(Cold Cathode Fluorescent Lamp) CHARACTERISTICS |       |    |
| 3.2.2 INVERTER CHARACTERISTICS                            |       |    |
| 3.2.3 INVERTER INTERTFACE CHARACTERISTICS                 |       |    |
| 4. BLOCK DIAGRAM  | ----- | 13 |
| 4.1 TFT LCD MODULE  |       |    |
| 5. INTERFACE PIN CONNECTION                               | ----- | 14 |
| 5.1 TFT LCD MODULE  |       |    |
| 5.2 BACKLIGHT UNIT  |       |    |
| 5.3 INVERTER UNIT   |       |    |
| 5.4 BLOCK DIAGRAM OF INTERFACE                            |       |    |
| 5.5 LVDS INTERFACE  |       |    |
| 5.6 COLOR DATA INPUT ASSIGNMENT                           |       |    |
| 6. INTERFACE TIMING                                       | ----- | 23 |
| 6.1 INPUT SIGNAL TIMING SPECIFICATIONS                    |       |    |
| 6.2 POWER ON/OFF SEQUENCE                                 |       |    |
| 7. OPTICAL CHARACTERISTICS                                | ----- | 26 |
| 7.1 TEST CONDITIONS                                       |       |    |
| 7.2 OPTICAL SPECIFICATIONS                                |       |    |
| 8. DEFINITION OF LABELS                                   | ----- | 30 |
| 8.1 CMO MODULE LABEL                                      |       |    |
| 9. PACKAGING  | ----- | 31 |
| 9.1 PACKING SPECIFICATIONS                                |       |    |
| 9.2 PACKING METHOD  |       |    |
| 10. PRECAUTIONS   | ----- | 33 |
| 10.1 ASSEMBLY AND HANDLING PRECAUTIONS                    |       |    |
| 10.2 SAFETY PRECAUTIONS                                   |       |    |
| 10.3 SAFETY STANDARDS                                     |       |    |
| 11. MECHANICAL CHARACTERISTICS                            | ----- | 34 |

### REVISION HISTORY

| Version | Date         | Page (New) | Section | Description                                 |
|---------|--------------|------------|---------|---|
| Ver 2.0 | Mar. 24,'09  | All        | All     | Approval Specification was first issued.    |
| Ver 2.1 | Apr. 15, '09 | 6          | 2.2.2   | Delete External PWM Control                 |
|         |              | 9          | 3.2.2   | Update Power Consumption Value(W): Max. 230 |
|         |              | 11         | 3.2.3   | Modify INVERTER INTERTFACE CHARACTERISTICS  |
|         |              | 13         | 4.1     | Modify BLOCK DIAGRAM OF INTERFACE           |
|         |              | 17         | 5.3     | Modify INVERTER UNIT                        |

## 1. GENERAL DESCRIPTION

### 1.1 OVERVIEW

V460H1-L07 is a 46" TFT Liquid Crystal Display module with 24-CCFL Backlight unit and 2ch-LVDS interface. This module supports 1920 x 1080 HDTV format and can display true 16.7M colors (8-bit/color).

The inverter module for backlight is built-in.

### 1.2 FEATURES

- High brightness (500nits)
- High contrast ratio (4000:1)
- Fast response time (Gray to Gray average 6.5 ms)
- High color saturation (72% NTSC)
- Full HDTV (1920 x 1080 pixels) resolution, true HDTV format
- DE (Data Enable) only mode
- LVDS (Low Voltage Differential Signaling) interface
- Optimized response time for 50/60 Hz frame rate
- Ultra wide viewing angle: Super MVA technology

### 1.3 APPLICATION

- Standard Living Room TVs.
- Public Display Application.
- Home Theater Application.
- MFM Application.

### 1.4 GENERAL SPECIFICATIONS

| Item                   | Specification                                  | Unit  | Note |
|------------------------|--|-------|------|
| Active Area            | 1018.08(H) x 572.67(V) (46" diagonal)          | mm    | (1)  |
| Bezel Opening Area     | 1024.4(H) x 578.6(V)                           | mm    |      |
| Driver Element         | a-si TFT active matrix                         | -     | -    |
| Pixel Number           | 1920x R.G.B. x 1080                            | pixel | -    |
| Pixel Pitch(Sub Pixel) | 0.17675(H) x 0.53025(V)                        | mm    | -    |
| Pixel Arrangement      | RGB vertical stripe                            | -     | -    |
| Display Colors         | 16.7M  | color | -    |
| Display Operation Mode | Transmissive mode / Normally black             | -     | -    |
| Surface Treatment      | Anti-Glare coating (Haze 17%)<br>Hardness (3H) | -     | (2)  |

Note (1) Please refer to the attached drawings in chapter 9 for more information about the front and back outlines.

Note (2) The spec of the surface treatment is temporarily for this phase. CMO reserves the rights to change this feature.

### 1.5 MECHANICAL SPECIFICATIONS

| Item        | Min.           | Typ.  | Max. | Unit | Note     |
|-------------|----------------|-------|------|------|----------|
| Module Size | Horizontal (H) | -     | 1083 | -    | (1), (2) |
|             | Vertical (V)   | -     | 627  | -    |          |
|             | Depth (D)      | -     | 50.6 | -    |          |
| Weight      | -              | 15400 | -    | g    | -        |

Note (1) Please refer to the attached drawings for more information of front and back outline dimensions.

Note (2) Module Depth does not include connectors.

## 2. ABSOLUTE MAXIMUM RATINGS

### 2.1 ABSOLUTE RATINGS OF ENVIRONMENT

| Item                          | Symbol           | Value     |      | Unit | Note     |
|-------------------------------|------------------|-----------|------|------|----------|
|                               |                  | Min.      | Max. |      |          |
| Storage Temperature           | T <sub>ST</sub>  | -20       | +60  | °C   | (1)      |
| Operating Ambient Temperature | T <sub>OP</sub>  | 0         | 50   | °C   | (1), (2) |
| Shock (Non-Operating)         | S <sub>NOP</sub> | X, Y axis | 50   | G    | (3), (5) |
|                               |                  | Z axis    | 35   | G    | (3), (5) |
| Vibration (Non-Operating)     | V <sub>NOP</sub> | -         | 1.0  | G    | (4), (5) |

Note (1) Temperature and relative humidity range is shown in the figure below.

- (a) 90 %RH Max. ( $T_a \leq 40 \text{ }^\circ\text{C}$ ).
- (b) Wet-bulb temperature should be 39 °C Max. ( $T_a > 40 \text{ }^\circ\text{C}$ ).
- (c) No condensation.

Note (2) The maximum operating temperature is based on the test condition that the surface temperature of display area is less than or equal to 65 °C with LCD module alone in a temperature controlled chamber. Thermal management should be considered in your product design to prevent the surface temperature of display area from being over 65 °C. The range of operating temperature may degrade in case of improper thermal management in your product design.

Note (3) 11 ms, half sine wave, 1 time for ± X, ± Y, and ± Z.

Note (4) 10 ~ 200 Hz, 10 min, 1 time each X, Y, Z.

Note (5) At testing Vibration and Shock, the fixture in holding the module has to be hard and rigid enough so that the module would not be twisted or bent by the fixture. The module would not be twisted or bent by the fixture.

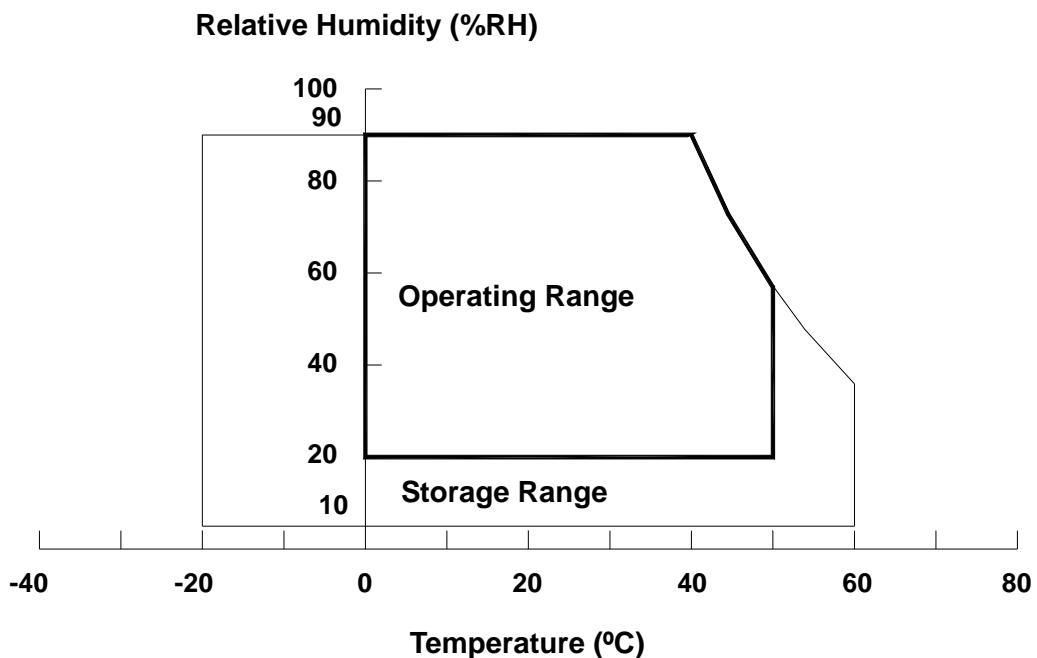

## 2.2 ELECTRICAL ABSOLUTE RATINGS

### 2.2.1 TFT LCD MODULE

| Item                 | Symbol   | Value |      | Unit | Note |
|----------------------|----------|-------|------|------|------|
|                      |          | Min.  | Max. |      |      |
| Power Supply Voltage | $V_{CC}$ | -0.3  | 13.5 | V    | (1)  |
| Logic Input Voltage  | $V_{IN}$ | -0.3  | 3.6  | V    |      |

### 2.2.2 BACKLIGHT INVERTER UNIT

| Item                 | Symbol   | Test Condition                   | Min. | Type | Max. | Unit      | Note     |
|----------------------|----------|----------------------------------|------|------|------|-----------|----------|
| Lamp Voltage         | $V_W$    | $T_a = 25\text{ }^\circ\text{C}$ | —    | —    | 3000 | $V_{RMS}$ |          |
| Power Supply Voltage | $V_{BL}$ | —                                | 0    | —    | 30   | V         | (1)      |
| Control Signal Level | —        | —                                | -0.3 | —    | 7    | V         | (1), (3) |

Note (1) Permanent damage to the device may occur if maximum values are exceeded. Functional operation should be restricted to the conditions described under normal operating conditions.

Note (2) No moisture condensation or freezing.

Note (3) The control signals includes Backlight On/Off Control, Internal PWM Control.

### 3. ELECTRICAL CHARACTERISTICS

#### 3.1 TFT LCD MODULE (Ta = 25 ± 2 °C)

| Parameter            |   | Symbol            | Value |      |       | Unit | Note |
|----------------------|---|-------------------|-------|------|-------|------|------|
|                      |   |                   | Min.  | Typ. | Max.  |      |      |
| Power Supply Voltage |   | V <sub>CC</sub>   | 10.8  | 12   | 13.2  | V    | (1)  |
| Rush Current         |   | I <sub>RUSH</sub> | -     | -    | 4.5   | A    | (2)  |
| Power Supply Current | White                                     | I <sub>CC</sub>   | -     | 1.3  | 2.0   | A    | (3)  |
|                      | Black                                     |                   | -     | 0.6  | -     | A    |      |
|                      | Vertical Stripe                           |                   | -     | 1.1  | -     | A    |      |
| LVDS Interface       | Differential Input High Threshold Voltage | V <sub>LVTH</sub> | -     | -    | +100  | mV   |      |
|                      | Differential Input Low Threshold Voltage  | V <sub>LVTL</sub> | -100  | -    | -     | mV   |      |
|                      | Common Input Voltage                      | V <sub>LVC</sub>  | 1.125 | 1.25 | 1.375 | V    |      |
|                      | Terminating Resistor                      | R <sub>T</sub>    | -     | 100  | -     | ohm  |      |
| CMOS interface       | Input High Threshold Voltage              | V <sub>IH</sub>   | 2.7   | -    | 3.3   | V    |      |
|                      | Input Low Threshold Voltage               | V <sub>IL</sub>   | 0     | -    | 0.7   | V    |      |

Note (1) The module should be always operated within the above ranges.

Note (2) Measurement condition:

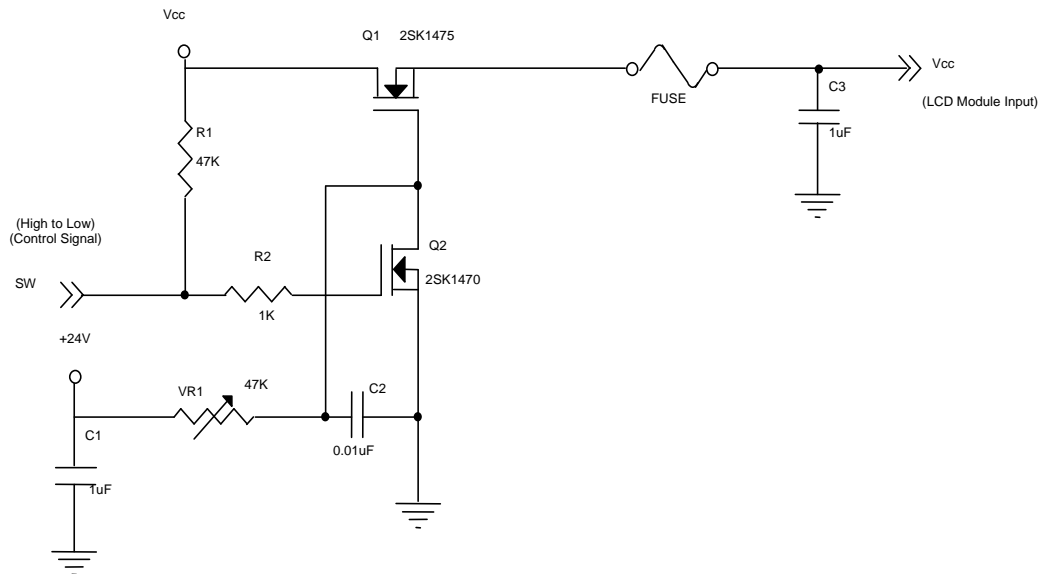

**Vcc rising time is 470us**

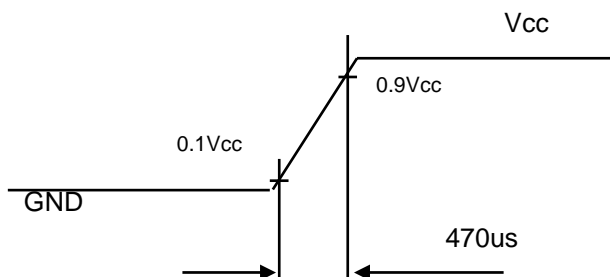

Note (3) The specified power supply current is under the conditions at  $V_{cc} = 12V$ ,  $T_a = 25 \pm 2 \text{ }^\circ\text{C}$ ,  $f_v = 60 \text{ Hz}$ , whereas a power dissipation check pattern below is displayed.

a. White Pattern



Active Area

b. Black Pattern

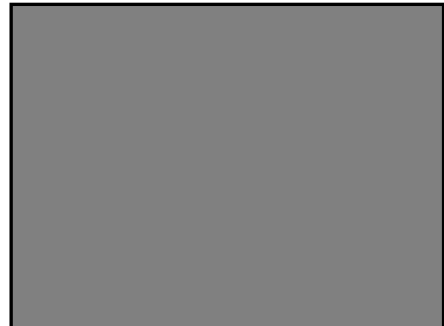

Active Area

c. Vertical Stripe Pattern

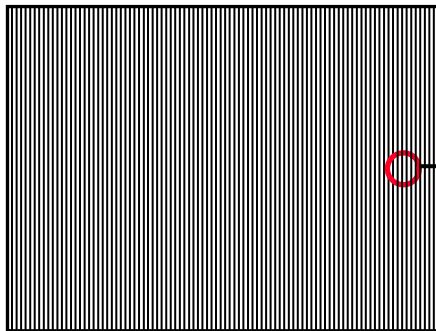

Active Area

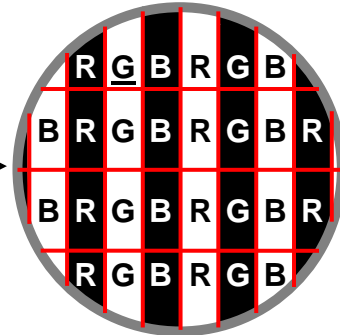



### 3.2 BACKLIGHT UNIT

#### 3.2.1 CCFL (Cold Cathode Fluorescent Lamp) CHARACTERISTICS (Ta = 25 ± 2 °C)

| Parameter            | Symbol          | Value  |      |      | Unit              | Note            |
|----------------------|-----------------|--------|------|------|-------------------|-----------------|
|                      |                 | Min.   | Typ. | Max. |                   |                 |
| Lamp Input Voltage   | V <sub>L</sub>  | -      | 1500 | -    | V <sub>RMS</sub>  | -               |
| Lamp Current         | I <sub>L</sub>  | 5.5    | 6.0  | 6.5  | mA <sub>RMS</sub> | (1)             |
| Lamp Turn On Voltage | V <sub>S</sub>  | -      | -    | 2360 | V <sub>RMS</sub>  | (2), Ta = 0 °C  |
|                      |                 | -      | -    | 2220 | V <sub>RMS</sub>  | (2), Ta = 25 °C |
| Operating Frequency  | F <sub>L</sub>  | 40     | -    | 80   | KHz               | (3)             |
| Lamp Life Time       | L <sub>BL</sub> | 50,000 | -    | -    | Hrs               | (4)             |

Note (1) Lamp current is measured by utilizing AC current probe and its value is average by measuring master and slave board.:

Note (2) The lamp starting voltage V<sub>S</sub> should be applied to the lamp for more than 1 second after startup. Otherwise the lamp may not be turned on.

Note (3) The lamp frequency may produce interference with horizontal synchronous frequency of the display input signals, and it may result in line flow on the display. In order to avoid interference, the lamp frequency should be detached from the horizontal synchronous frequency and its harmonics as far as possible.

Note (4) The life time of a lamp is defined as when the brightness is larger than 50% of its original value and the effective discharge length is longer than 80% of its original length (Effective discharge length is defined as an area that has equal to or more than 70% brightness compared to the brightness at the center point of lamp.) as the time in which it continues to operate under the condition at Ta = 25 ± 2°C and I<sub>L</sub> = 5.5~6.5 mA<sub>RMS</sub>.

#### 3.2.2 INVERTER CHARACTERISTICS (Ta = 25 ± 2 °C)

| Parameter             | Symbol           | Value |      |      | Unit              | Note                       |
|-----------------------|------------------|-------|------|------|-------------------|----------------------------|
|                       |                  | Min.  | Typ. | Max. |                   |                            |
| Power Consumption     | P <sub>BL</sub>  | —     | 210  | 230  | W                 | (5) I <sub>L</sub> = 6.0mA |
| Input Voltage         | V <sub>BL</sub>  | 22.8  | 24   | 25.2 | V <sub>DC</sub>   |                            |
| Input Current         | I <sub>BL</sub>  | —     | 8.75 | —    | A                 | Non Dimming                |
| Input Ripple Noise    | —                | —     | —    | 912  | mV <sub>P-P</sub> | V <sub>BL</sub> = 22.8V    |
| Oscillating Frequency | F <sub>W</sub>   | 45.0  | 48.0 | 51.0 | kHz               |                            |
| Dimming Frequency     | F <sub>B</sub>   | 150   | 160  | 170  | Hz                |                            |
| Minimum Duty Ratio    | D <sub>MIN</sub> |       | 20   | —    | %                 |                            |

Note (5) The power supply capacity should be higher than the total inverter power consumption P<sub>BL</sub>. Since the pulse width modulation (PWM) mode was applied for backlight dimming, the driving current changed as PWM duty on and off. The transient response of power supply should be considered for the changing loading when inverter dimming.

Note (6) The measurement of Max. value is based on 46" backlight unit under 24V input voltage and 6.3mA lamp in average after lighting for 30 minutes.

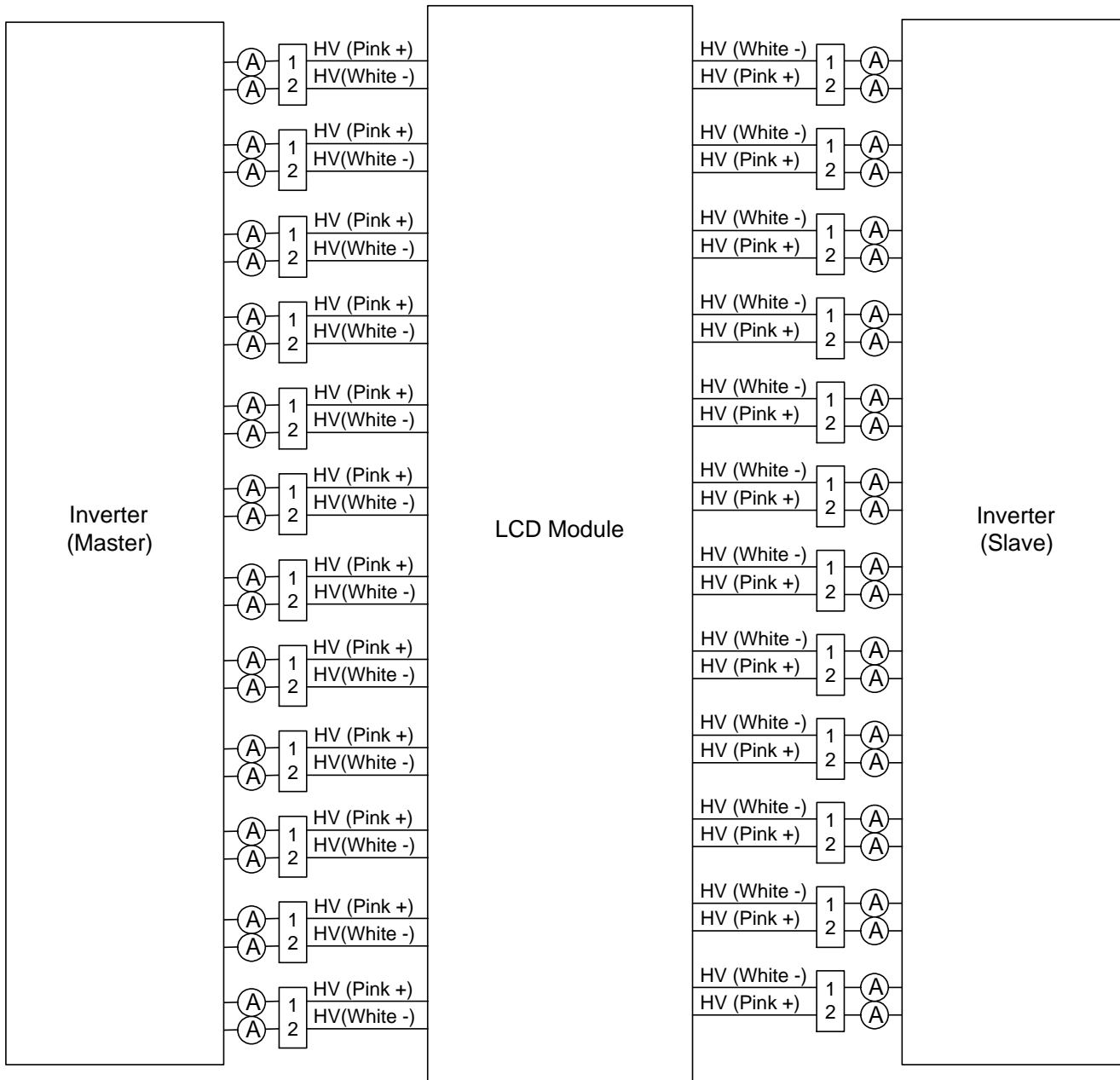

### 3.2.3 INVERTER INTERFACE CHARACTERISTICS

| Parameter                    | Symbol     | Test Condition | Value |      |      | Unit       | Note             |                    |
|------------------------------|------------|----------------|-------|------|------|------------|------------------|--------------------|
|                              |            |                | Min.  | Typ. | Max. |            |                  |                    |
| On/Off Control Voltage       | ON         | $V_{BLON}$     | —     | 2.0  | —    | 5.0        | V                |                    |
|                              | OFF        |                | —     | 0    | —    | 0.8        | V                |                    |
| Internal PWM Control Voltage | MAX        | $V_{IPWM}$     | —     | 3.15 | 3.3  | 3.45       | V                | Maximum duty ratio |
|                              | MIN        |                | —     | —    | 0    | —          | V                | Minimum duty ratio |
| External PWM Control Voltage | HI         | $V_{EPWM}$     | —     | 2.0  | —    | 5.0        | V                | Duty on            |
|                              | LO         |                | —     | 0    | —    | 0.8        | V                | Duty off           |
| Status Signal                | HI         | Status         | —     | 3.0  | 3.3  | 3.6        | V                | Normal             |
|                              | LO         |                | —     | 0    | —    | 0.8        | V                | Abnormal           |
| VBL Rising Time              | $T_{r1}$   | —              | 30    | —    | —    | ms         | 10%-90% $V_{BL}$ |                    |
| VBL Falling Time             | $T_{f1}$   | —              | 30    | —    | —    | ms         |                  |                    |
| Control Signal Rising Time   | $T_r$      | —              | —     | —    | 100  | ms         |                  |                    |
| Control Signal Falling Time  | $T_f$      | —              | —     | —    | 100  | ms         |                  |                    |
| PWM Signal Rising Time       | $T_{PWMR}$ | —              | —     | —    | 50   | us         |                  |                    |
| PWM Signal Falling Time      | $T_{PWMF}$ | —              | —     | —    | 50   | us         |                  |                    |
| Input impedance              | $R_{IN}$   | —              | 1     | —    | —    | M $\Omega$ |                  |                    |
| PWM Delay Time               | $T_{PWM}$  | —              | 100   | —    | —    | ms         |                  |                    |
| BLON Delay Time              | $T_{on}$   | —              | 300   | —    | —    | ms         |                  |                    |
|                              | $T_{on1}$  | —              | 300   | —    | —    | ms         |                  |                    |
| BLON Off Time                | $T_{off}$  | —              | 300   | —    | —    | ms         |                  |                    |

Note (1) The Dimming signal should be valid before backlight turns on by BLON signal. It is inhibited to change the internal PWM signal during backlight turn on period.

Note (2) The power sequence and control signal timing are shown in the following figure. For a certain reason, the inverter has a possibility to be damaged with wrong power sequence and control signal timing.

Note (3) While system is turned ON or OFF, the power sequences must follow as below descriptions:

Turn ON sequence: VBL → PWM signal → BLON

Turn OFF sequence: BLOFF → PWM signal → VBL

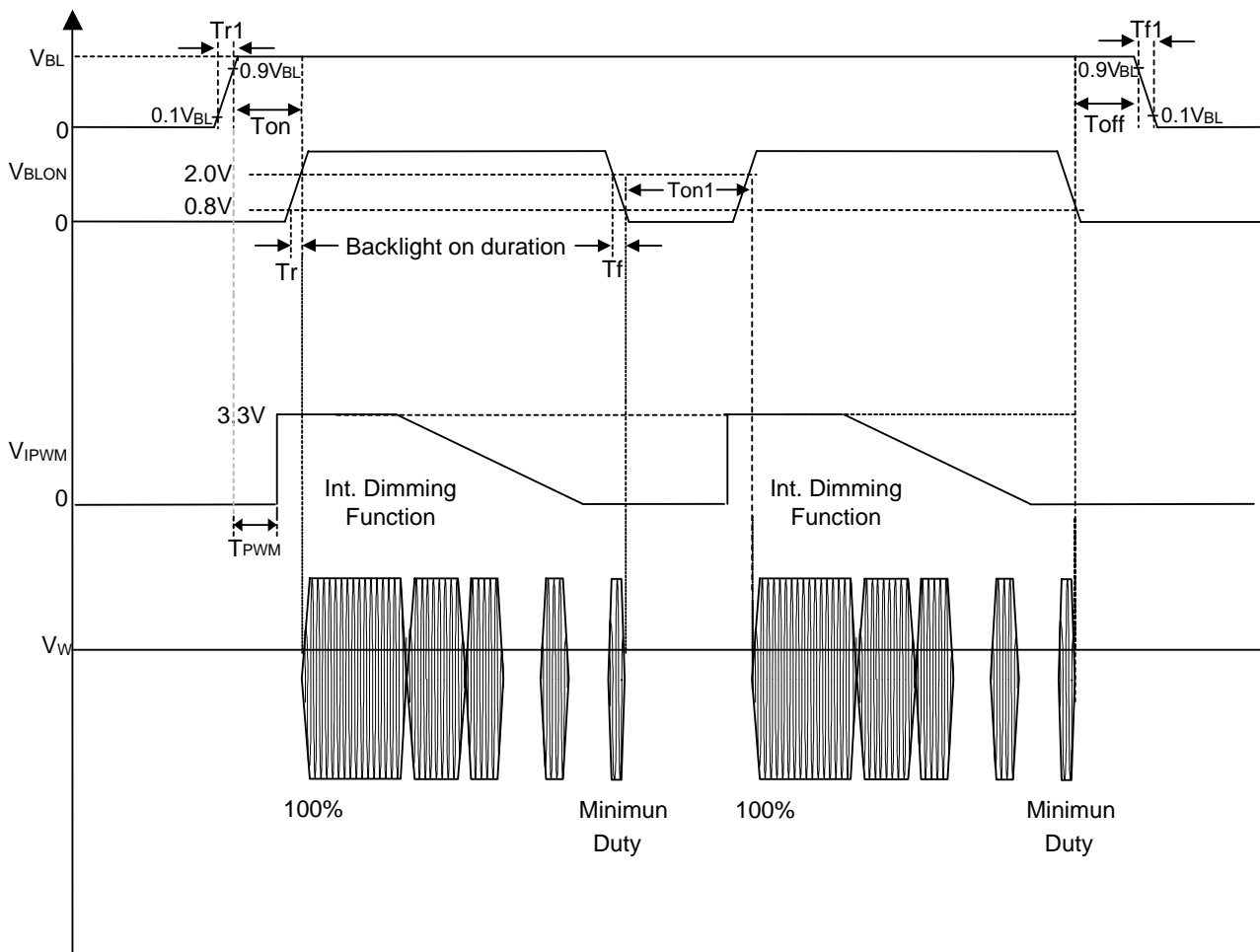

#### 4. BLOCK DIAGRAM OF INTERFACE

##### 4.1 TFT LCD MODULE

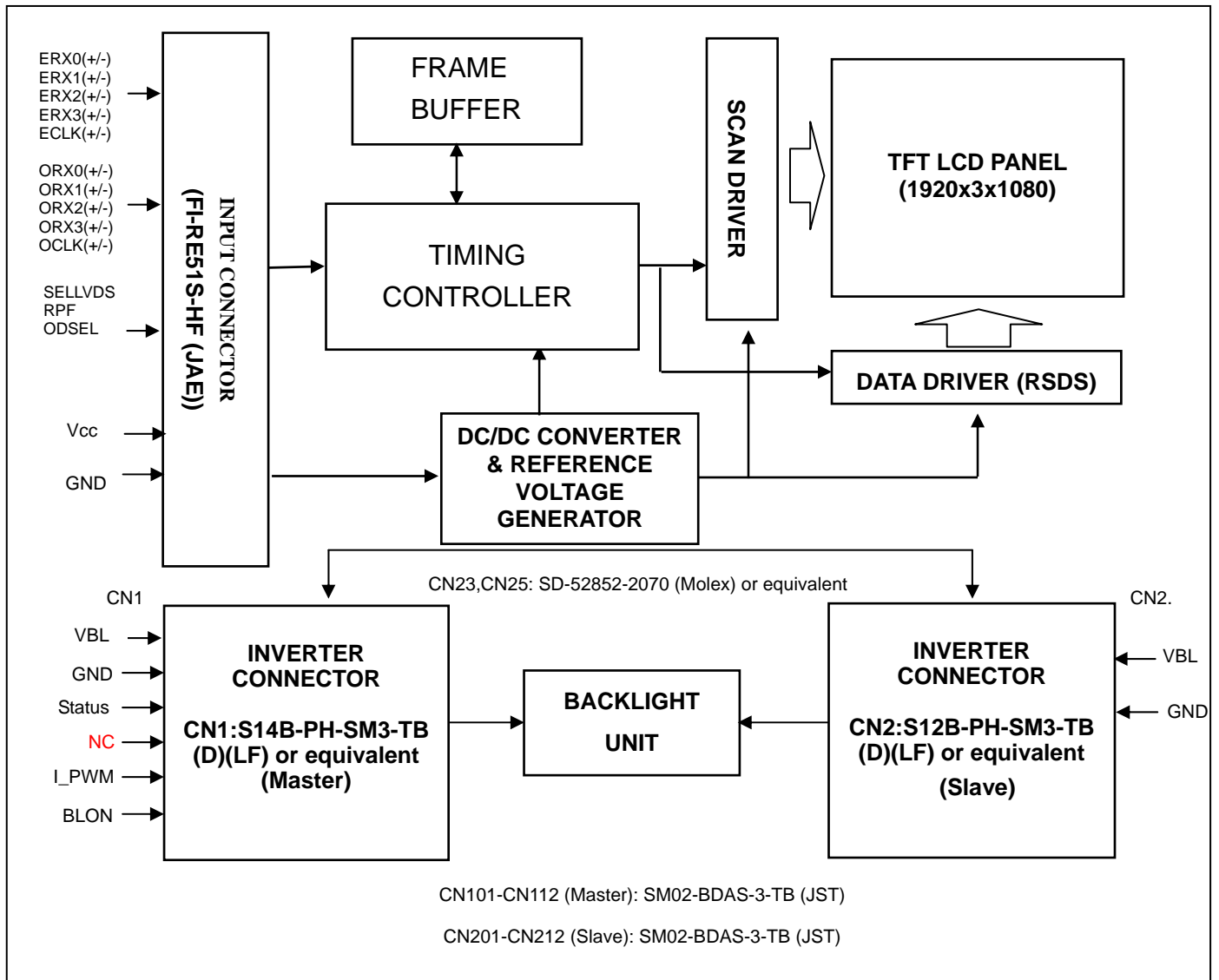

## 5 .INPUT TERMINAL PIN ASSIGNMENT

### 5.1 TFT LCD Module

| Pin | Name    | Description  | Note |
|-----|---------|--|------|
| 1   | VCC     | +12V power supply  |      |
| 2   | VCC     | +12V power supply  |      |
| 3   | VCC     | +12V power supply  |      |
| 4   | VCC     | +12V power supply  |      |
| 5   | VCC     | +12V power supply  |      |
| 6   | GND     | Ground   |      |
| 7   | GND     | Ground   |      |
| 8   | GND     | Ground   |      |
| 9   | GND     | Ground   |      |
| 10  | ORX0-   | Odd pixel Negative LVDS differential data input. Channel 0   |      |
| 11  | ORX0+   | Odd pixel Positive LVDS differential data input. Channel 0   |      |
| 12  | ORX1-   | Odd pixel Negative LVDS differential data input. Channel 1   |      |
| 13  | ORX1+   | Odd pixel Positive LVDS differential data input. Channel 1   |      |
| 14  | ORX2-   | Odd pixel Negative LVDS differential data input. Channel 2   |      |
| 15  | ORX2+   | Odd pixel Positive LVDS differential data input. Channel 2   |      |
| 16  | GND     | Ground   |      |
| 17  | OCLK-   | Odd pixel Negative LVDS differential clock input.            |      |
| 18  | OCLK+   | Odd pixel Positive LVDS differential clock input.            |      |
| 19  | GND     | Ground   |      |
| 20  | ORX3-   | Odd pixel Negative LVDS differential data input. Channel 3   |      |
| 21  | ORX3+   | Odd pixel Positive LVDS differential data input. Channel 3   |      |
| 22  | N.C.    | No Connection  | (1)  |
| 23  | N.C.    | No Connection  |      |
| 24  | GND     | Ground   |      |
| 25  | ERX0-   | Even pixel, Negative LVDS differential data input. Channel 0 |      |
| 26  | ERX0+   | Even pixel, Positive LVDS differential data input. Channel 0 |      |
| 27  | ERX1-   | Even pixel, Negative LVDS differential data input. Channel 1 |      |
| 28  | ERX1+   | Even pixel, Positive LVDS differential data input. Channel 1 |      |
| 29  | ERX2-   | Even pixel, Negative LVDS differential data input. Channel 2 |      |
| 30  | ERX2+   | Even pixel, Positive LVDS differential data input. Channel 2 |      |
| 31  | GND     | Ground   |      |
| 32  | ECLK-   | Even pixel, Negative LVDS differential clock input           |      |
| 33  | ECLK+   | Even pixel, Positive LVDS differential clock input.          |      |
| 34  | GND     | Ground   |      |
| 35  | ERX3-   | Even pixel, Negative LVDS differential data input. Channel 3 |      |
| 36  | ERX3+   | Even pixel, Positive LVDS differential data input. Channel 3 |      |
| 37  | N.C.    | No Connection  | (1)  |
| 38  | N.C.    | No Connection  |      |
| 39  | GND     | Ground   |      |
| 40  | ODSEL   | Overdrive Lookup Table Selection                             | (3)  |
| 41  | N.C.    | No Connection  | (1)  |
| 42  | N.C.    | No Connection  | (1)  |
| 43  | N.C.    | No Connection  |      |
| 44  | N.C.    | No Connection  | (1)  |
| 45  | SELLVDS | LVDS Data Format Selection                                   | (2)  |
| 46  | N.C.    | No Connection  | (1)  |
| 47  | N.C.    | No Connection  |      |
| 48  | N.C.    | No Connection  |      |

|    |      |               |     |
|----|------|---------------|-----|
| 49 | N.C. | No Connection | (1) |
| 50 | N.C. | No Connection |     |
| 51 | N.C. | No Connection |     |

Note (1) Reserved for internal use. Please leave it open.

Note (2) Low : JEIDA LVDS Format (default), High : VESA Format.

Note (3) Overdrive lookup table selection. The overdrive lookup table should be selected in accordance with the frame rate to optimize image quality.

| ODSEL | Note   |
|-------|--|
| L     | Lookup table was optimized for 60 Hz frame rate  |
| H     | Lookup table was optimized for 50 Hz frame rate. |

Note (4) Low =Open or Connect to GND, High = Connect to +3.3V

### 5.2 BACKLIGHT UNIT

The pin configuration for the housing and the leader wire is shown in the table below.

CN3-CN26: BDAMR-02VAS-3 (JST).

| Pin | Name | Description  | Wire Color |
|-----|------|--------------|------------|
| 1   | HV   | High Voltage | Pink       |
| 2   | HV   | High Voltage | White      |

Note (1) The backlight interface housing for high voltage side is a model BDAMR-02VAS-3, manufactured by JST. The mating header on inverter part number is SM02-BDAS-3-TB (LF)(JST)

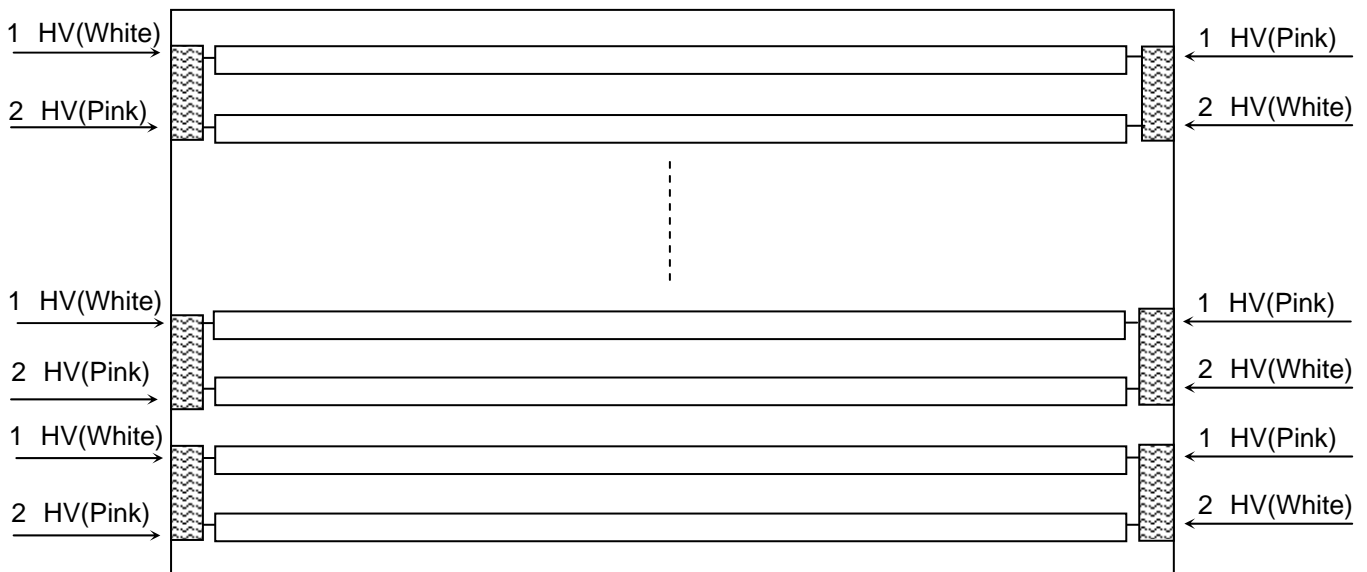



### 5.3 INVERTER UNIT

CN1 (Master) (Header): S14B-PH-SM3-TB (D)(LF)(JST) or equivalent.

| Pin No. | Symbol | Description                     |
|---------|--------|---------------------------------|
| 1       | VBL    | +24V <sub>DC</sub> power input  |
| 2       |        |                                 |
| 3       |        |                                 |
| 4       |        |                                 |
| 5       |        |                                 |
| 6       | GND    | GND                             |
| 7       |        |                                 |
| 8       |        |                                 |
| 9       |        |                                 |
| 10      |        |                                 |
| 11      | Status | Normal (3.3V)<br>Abnormal (GND) |
| 12      | NC     | NC                              |
| 13      | I_PWM  | Internal PWM Control Signal     |
| 14      | BLON   | Backlight on/off control        |

Notice:

Note (1) PIN 13: Internal PWM Control (Use Pin 13): Pin 12 must open.

Note (2) Pin 13(I\_PWM) and Pin 12 can't open in same period.

CN2 (Slave) (Header): S12B-PH-SM3-TB (D)(LF)(JST) or equivalent.

| Pin No. | Symbol | Description                    |
|---------|--------|--------------------------------|
| 1       | VBL    | +24V <sub>DC</sub> power input |
| 2       |        |                                |
| 3       |        |                                |
| 4       |        |                                |
| 5       |        |                                |
| 6       | GND    | GND                            |
| 7       |        |                                |
| 8       |        |                                |
| 9       |        |                                |
| 10      |        |                                |
| 11      | NC     | NC                             |
| 12      | NC     | NC                             |

CN101-CN112 (Master) (Header): SM02-BDAS-3-TB (JST)

| Pin No. | Symbol   | Description       |
|---------|----------|-------------------|
| 1       | CCFL HOT | CCFL high voltage |
| 2       | CCFL HOT | CCFL high voltage |

CN201-CN212 (Slave) (Header): SM02-BDAS-3-TB (JST)

| Pin No. | Symbol   | Description       |
|---------|----------|-------------------|
| 1       | CCFL HOT | CCFL high voltage |
| 2       | CCFL HOT | CCFL high voltage |

CN23 (Master)-CN25 (Slave) (Header): 52852-2070 (Molex) or equivalent

| Pin No. | Symbol            | Description    |
|---------|-------------------|----------------|
| 1       | Control<br>Signal | Board to Board |
| 2       |                   | Board to Board |
| 3       |                   | Board to Board |
| 4       |                   | Board to Board |
| 5       |                   | Board to Board |
| 6       |                   | Board to Board |
| 7       |                   | Board to Board |
| 8       |                   | Board to Board |
| 9       |                   | Board to Board |
| 10      |                   | Board to Board |
| 11      |                   | Board to Board |
| 12      |                   | Board to Board |
| 13      |                   | Board to Board |
| 14      |                   | Board to Board |
| 15      |                   | Board to Board |
| 16      |                   | Board to Board |
| 17      |                   | Board to Board |
| 18      |                   | Board to Board |
| 19      |                   | Board to Board |
| 20      |                   | Board to Board |

Note (1) Floating of any control signal is not allowed.

**5.4 BLOCK DIAGRAM OF INTERFACE**

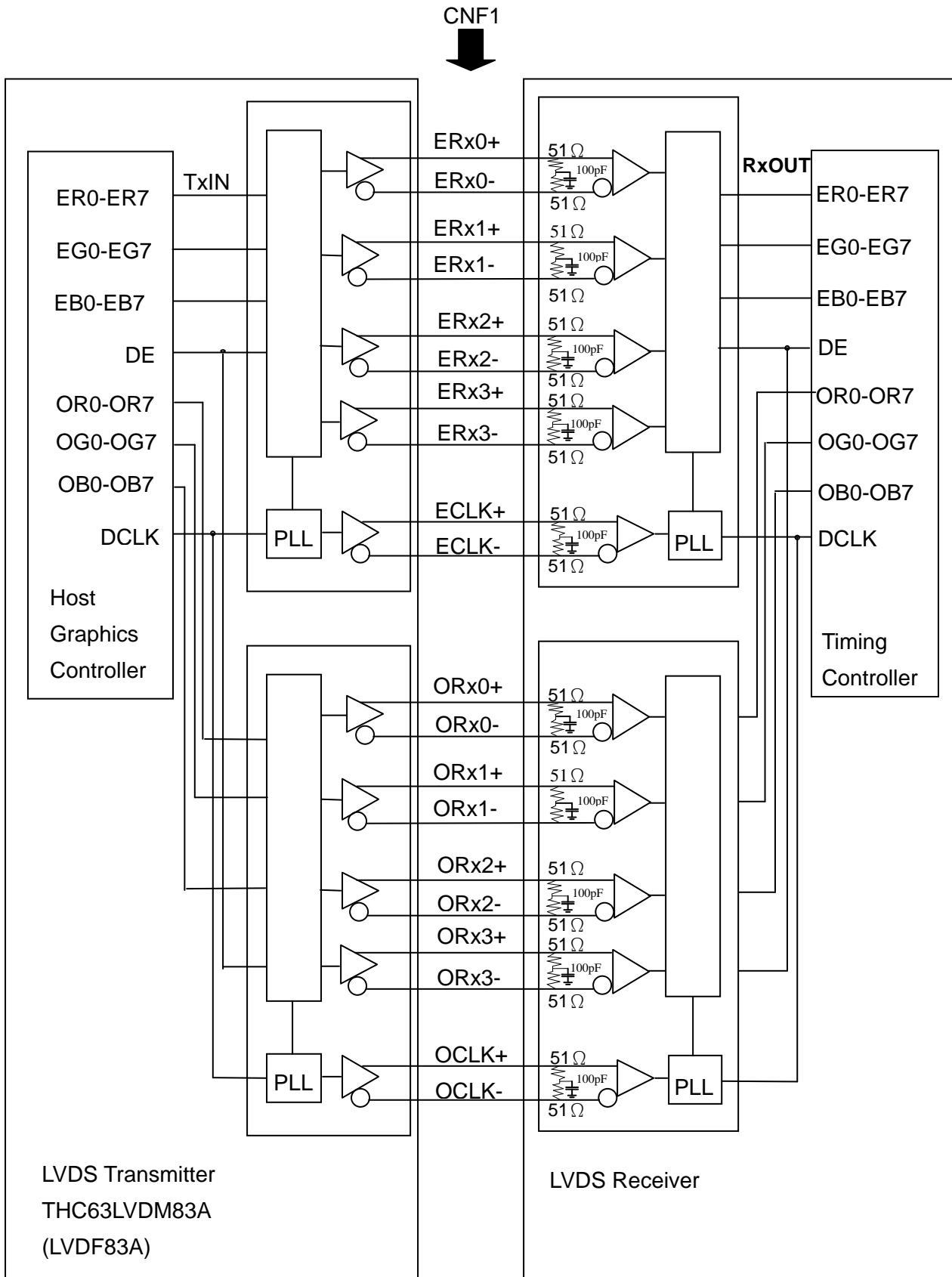

ER0~ER7 : Even pixel R data

EG0~EG7 : Even pixel G data

EB0~EB7 : Even pixel B data

OR0~OR7 : Odd pixel R data

OG0~OG7 : Odd pixel G data

OB0~OB7 : Odd pixel B data

DE : Data enable signal

DCLK : Data clock signal

Notes:

- (1) The system must have the transmitter to drive the module.
- (2) LVDS cable impedance shall be 50 ohms per signal line or about 100 ohms per twist-pair line when it is used differentially.
- (3) Two pixel data send into the module for every clock cycle. The first pixel of the frame is odd pixel and the second pixel is even pixel.

### 5.5 LVDS INTERFACE

|       | SIGNAL      |                      | TRANSMITTER<br>THC63LVDM83A |          | INTERFACE<br>CONNECTOR |           | RECEIVER<br>THC63LVDF84A |           | TFT CONTROL INPUT |                      |
|-------|-------------|----------------------|-----------------------------|----------|------------------------|-----------|--------------------------|-----------|-------------------|----------------------|
|       | LVDS_SEL =H | LVDS_SEL = L or OPEN | PIN                         | INPUT    | Host                   | TFT-LCD   | PIN                      | OUTPUT    | LVDS_SEL =H       | LVDS_SEL = L or OPEN |
| 24bit | R0          | R2                   | 51                          | TxIN0    |                        |           | 27                       | Rx OUT0   | R0                | R2                   |
|       | R1          | R3                   | 52                          | TxIN1    |                        |           | 29                       | Rx OUT1   | R1                | R3                   |
|       | R2          | R4                   | 54                          | TxIN2    | TA OUT0+               | Rx 0+     | 30                       | Rx OUT2   | R2                | R4                   |
|       | R3          | R5                   | 55                          | TxIN3    |                        |           | 32                       | Rx OUT3   | R3                | R5                   |
|       | R4          | R6                   | 56                          | TxIN4    |                        |           | 33                       | Rx OUT4   | R4                | R6                   |
|       | R5          | R7                   | 3                           | TxIN6    | TA OUT0-               | Rx 0-     | 35                       | Rx OUT6   | R5                | R7                   |
|       | G0          | G2                   | 4                           | TxIN7    |                        |           | 37                       | Rx OUT7   | G0                | G2                   |
|       | G1          | G3                   | 6                           | TxIN8    |                        |           | 38                       | Rx OUT8   | G1                | G3                   |
|       | G2          | G4                   | 7                           | TxIN9    |                        |           | 39                       | Rx OUT9   | G2                | G4                   |
|       | G3          | G5                   | 11                          | TxIN12   | TA OUT1+               | Rx 1+     | 43                       | Rx OUT12  | G3                | G5                   |
|       | G4          | G6                   | 12                          | TxIN13   |                        |           | 45                       | Rx OUT13  | G4                | G6                   |
|       | G5          | G7                   | 14                          | TxIN14   |                        |           | 46                       | Rx OUT14  | G5                | G7                   |
|       | B0          | B2                   | 15                          | TxIN15   | TA OUT1-               | Rx 1-     | 47                       | Rx OUT15  | B0                | B2                   |
|       | B1          | B3                   | 19                          | TxIN18   |                        |           | 51                       | Rx OUT18  | B1                | B3                   |
|       | B2          | B4                   | 20                          | TxIN19   |                        |           | 53                       | Rx OUT19  | B2                | B4                   |
|       | B3          | B5                   | 22                          | TxIN20   |                        |           | 54                       | Rx OUT20  | B3                | B5                   |
|       | B4          | B6                   | 23                          | TxIN21   | TA OUT2+               | Rx 2+     | 55                       | Rx OUT21  | B4                | B6                   |
|       | B5          | B7                   | 24                          | TxIN22   |                        |           | 1                        | Rx OUT22  | B5                | B7                   |
|       | DE          | DE                   | 30                          | TxIN26   |                        |           | 6                        | Rx OUT26  | DE                | DE                   |
|       | R6          | R0                   | 50                          | TxIN27   | TA OUT2-               | Rx 2-     | 7                        | Rx OUT27  | R6                | R0                   |
|       | R7          | R1                   | 2                           | TxIN5    |                        |           | 34                       | Rx OUT5   | R7                | R1                   |
|       | G6          | G0                   | 8                           | TxIN10   |                        |           | 41                       | Rx OUT10  | G6                | G0                   |
|       | G7          | G1                   | 10                          | TxIN11   |                        |           | 42                       | Rx OUT11  | G7                | G1                   |
|       | B6          | B0                   | 16                          | TxIN16   | TA OUT3+               | Rx 3+     | 49                       | Rx OUT16  | B6                | B0                   |
|       | B7          | B1                   | 18                          | TxIN17   |                        |           | 50                       | Rx OUT17  | B7                | B1                   |
|       | RSVD 1      | RSVD 1               | 25                          | TxIN23   |                        |           | 2                        | Rx OUT23  | NC                | NC                   |
|       | RSVD 2      | RSVD 2               | 27                          | TxIN24   | TA OUT3-               | Rx 3-     | 3                        | Rx OUT24  | NC                | NC                   |
|       | RSVD 3      | RSVD 3               | 28                          | TxIN25   |                        |           | 5                        | Rx OUT25  | NC                | NC                   |
| DCLK  |             |                      | 31                          | TxCLK IN | TxCLK OUT+             | RxCLK IN+ | 26                       | RxCLK OUT | DCLK              |                      |
|       |             |                      |                             |          | TxCLK OUT-             | RxCLK IN- |                          |           |                   |                      |

R0~R7: Pixel R Data (7; MSB, 0; LSB)

G0~G7: Pixel G Data (7; MSB, 0; LSB)

B0~B7: Pixel B Data (7; MSB, 0; LSB)

DE : Data enable signal

DCLK : Data clock signal

Notes (1) RSVD (reserved) pins on the transmitter shall be "H" or "L".

### 5.6 COLOR DATA INPUT ASSIGNMENT

The brightness of each primary color (red, green and blue) is based on the 8-bit gray scale data input for the color. The higher the binary input, the brighter the color. The table below provides the assignment of the color versus data input.

| Color               |                  | Data Signal |    |    |    |    |    |    |    |       |    |    |    |    |    |    |    |      |    |    |    |    |    |    |
|---------------------|------------------|-------------|----|----|----|----|----|----|----|-------|----|----|----|----|----|----|----|------|----|----|----|----|----|----|
|                     |                  | Red         |    |    |    |    |    |    |    | Green |    |    |    |    |    |    |    | Blue |    |    |    |    |    |    |
|                     |                  | R7          | R6 | R5 | R4 | R3 | R2 | R1 | R0 | G7    | G6 | G5 | G4 | G3 | G2 | G1 | G0 | B7   | B6 | B5 | B4 | B3 | B2 | B1 |
| Basic Colors        | Black            | 0           | 0  | 0  | 0  | 0  | 0  | 0  | 0  | 0     | 0  | 0  | 0  | 0  | 0  | 0  | 0  | 0    | 0  | 0  | 0  | 0  | 0  | 0  |
|                     | Red              | 1           | 1  | 1  | 1  | 1  | 1  | 1  | 1  | 0     | 0  | 0  | 0  | 0  | 0  | 0  | 0  | 0    | 0  | 0  | 0  | 0  | 0  | 0  |
|                     | Green            | 0           | 0  | 0  | 0  | 0  | 0  | 0  | 0  | 1     | 1  | 1  | 1  | 1  | 1  | 1  | 1  | 0    | 0  | 0  | 0  | 0  | 0  | 0  |
|                     | Blue             | 0           | 0  | 0  | 0  | 0  | 0  | 0  | 0  | 0     | 0  | 0  | 0  | 0  | 0  | 0  | 0  | 1    | 1  | 1  | 1  | 1  | 1  | 1  |
|                     | Cyan             | 0           | 0  | 0  | 0  | 0  | 0  | 0  | 0  | 1     | 1  | 1  | 1  | 1  | 1  | 1  | 1  | 1    | 1  | 1  | 1  | 1  | 1  | 1  |
|                     | Magenta          | 1           | 1  | 1  | 1  | 1  | 1  | 1  | 1  | 0     | 0  | 0  | 0  | 0  | 0  | 0  | 0  | 1    | 1  | 1  | 1  | 1  | 1  | 1  |
|                     | Yellow           | 1           | 1  | 1  | 1  | 1  | 1  | 1  | 1  | 1     | 1  | 1  | 1  | 1  | 1  | 1  | 1  | 0    | 0  | 0  | 0  | 0  | 0  | 0  |
|                     | White            | 1           | 1  | 1  | 1  | 1  | 1  | 1  | 1  | 1     | 1  | 1  | 1  | 1  | 1  | 1  | 1  | 1    | 1  | 1  | 1  | 1  | 1  | 1  |
| Gray Scale Of Red   | Red (0) / Dark   | 0           | 0  | 0  | 0  | 0  | 0  | 0  | 0  | 0     | 0  | 0  | 0  | 0  | 0  | 0  | 0  | 0    | 0  | 0  | 0  | 0  | 0  |    |
|                     | Red (1)          | 0           | 0  | 0  | 0  | 0  | 0  | 0  | 1  | 0     | 0  | 0  | 0  | 0  | 0  | 0  | 0  | 0    | 0  | 0  | 0  | 0  | 0  |    |
|                     | Red (2)          | 0           | 0  | 0  | 0  | 0  | 0  | 1  | 0  | 0     | 0  | 0  | 0  | 0  | 0  | 0  | 0  | 0    | 0  | 0  | 0  | 0  | 0  |    |
|                     | ⋮                | ⋮           | ⋮  | ⋮  | ⋮  | ⋮  | ⋮  | ⋮  | ⋮  | ⋮     | ⋮  | ⋮  | ⋮  | ⋮  | ⋮  | ⋮  | ⋮  | ⋮    | ⋮  | ⋮  | ⋮  | ⋮  | ⋮  |    |
|                     | ⋮                | ⋮           | ⋮  | ⋮  | ⋮  | ⋮  | ⋮  | ⋮  | ⋮  | ⋮     | ⋮  | ⋮  | ⋮  | ⋮  | ⋮  | ⋮  | ⋮  | ⋮    | ⋮  | ⋮  | ⋮  | ⋮  | ⋮  |    |
|                     | Red (253)        | 1           | 1  | 1  | 1  | 1  | 1  | 0  | 1  | 0     | 0  | 0  | 0  | 0  | 0  | 0  | 0  | 0    | 0  | 0  | 0  | 0  | 0  |    |
|                     | Red (254)        | 1           | 1  | 1  | 1  | 1  | 1  | 1  | 0  | 0     | 0  | 0  | 0  | 0  | 0  | 0  | 0  | 0    | 0  | 0  | 0  | 0  | 0  |    |
| Red (255)           | 1                | 1           | 1  | 1  | 1  | 1  | 1  | 1  | 0  | 0     | 0  | 0  | 0  | 0  | 0  | 0  | 0  | 0    | 0  | 0  | 0  | 0  |    |    |
| Gray Scale Of Green | Green (0) / Dark | 0           | 0  | 0  | 0  | 0  | 0  | 0  | 0  | 0     | 0  | 0  | 0  | 0  | 0  | 0  | 0  | 0    | 0  | 0  | 0  | 0  | 0  |    |
|                     | Green (1)        | 0           | 0  | 0  | 0  | 0  | 0  | 0  | 0  | 0     | 0  | 0  | 0  | 0  | 0  | 1  | 0  | 0    | 0  | 0  | 0  | 0  | 0  |    |
|                     | Green (2)        | 0           | 0  | 0  | 0  | 0  | 0  | 0  | 0  | 0     | 0  | 0  | 0  | 0  | 1  | 0  | 0  | 0    | 0  | 0  | 0  | 0  |    |    |
|                     | ⋮                | ⋮           | ⋮  | ⋮  | ⋮  | ⋮  | ⋮  | ⋮  | ⋮  | ⋮     | ⋮  | ⋮  | ⋮  | ⋮  | ⋮  | ⋮  | ⋮  | ⋮    | ⋮  | ⋮  | ⋮  | ⋮  |    |    |
|                     | ⋮                | ⋮           | ⋮  | ⋮  | ⋮  | ⋮  | ⋮  | ⋮  | ⋮  | ⋮     | ⋮  | ⋮  | ⋮  | ⋮  | ⋮  | ⋮  | ⋮  | ⋮    | ⋮  | ⋮  | ⋮  | ⋮  |    |    |
|                     | Green (253)      | 0           | 0  | 0  | 0  | 0  | 0  | 0  | 0  | 1     | 1  | 1  | 1  | 1  | 1  | 0  | 1  | 0    | 0  | 0  | 0  | 0  | 0  |    |
|                     | Green (254)      | 0           | 0  | 0  | 0  | 0  | 0  | 0  | 0  | 1     | 1  | 1  | 1  | 1  | 1  | 0  | 0  | 0    | 0  | 0  | 0  | 0  | 0  |    |
| Green (255)         | 0                | 0           | 0  | 0  | 0  | 0  | 0  | 0  | 1  | 1     | 1  | 1  | 1  | 1  | 1  | 0  | 0  | 0    | 0  | 0  | 0  | 0  |    |    |
| Gray Scale Of Blue  | Blue (0) / Dark  | 0           | 0  | 0  | 0  | 0  | 0  | 0  | 0  | 0     | 0  | 0  | 0  | 0  | 0  | 0  | 0  | 0    | 0  | 0  | 0  | 0  | 0  |    |
|                     | Blue (1)         | 0           | 0  | 0  | 0  | 0  | 0  | 0  | 0  | 0     | 0  | 0  | 0  | 0  | 0  | 0  | 0  | 0    | 0  | 0  | 0  | 0  | 1  |    |
|                     | Blue (2)         | 0           | 0  | 0  | 0  | 0  | 0  | 0  | 0  | 0     | 0  | 0  | 0  | 0  | 0  | 0  | 0  | 0    | 0  | 0  | 0  | 0  | 1  |    |
|                     | ⋮                | ⋮           | ⋮  | ⋮  | ⋮  | ⋮  | ⋮  | ⋮  | ⋮  | ⋮     | ⋮  | ⋮  | ⋮  | ⋮  | ⋮  | ⋮  | ⋮  | ⋮    | ⋮  | ⋮  | ⋮  | ⋮  |    |    |
|                     | ⋮                | ⋮           | ⋮  | ⋮  | ⋮  | ⋮  | ⋮  | ⋮  | ⋮  | ⋮     | ⋮  | ⋮  | ⋮  | ⋮  | ⋮  | ⋮  | ⋮  | ⋮    | ⋮  | ⋮  | ⋮  | ⋮  |    |    |
|                     | Blue (253)       | 0           | 0  | 0  | 0  | 0  | 0  | 0  | 0  | 0     | 0  | 0  | 0  | 0  | 0  | 0  | 1  | 1    | 1  | 1  | 1  | 1  | 0  |    |
|                     | Blue (254)       | 0           | 0  | 0  | 0  | 0  | 0  | 0  | 0  | 0     | 0  | 0  | 0  | 0  | 0  | 0  | 1  | 1    | 1  | 1  | 1  | 1  | 1  |    |
| Blue (255)          | 0                | 0           | 0  | 0  | 0  | 0  | 0  | 0  | 0  | 0     | 0  | 0  | 0  | 0  | 0  | 1  | 1  | 1    | 1  | 1  | 1  | 1  |    |    |

Note (1) 0: Low Level Voltage, 1: High Level Voltage

## 6. INTERFACE TIMING

### 6.1 INPUT SIGNAL TIMING SPECIFICATIONS

The input signal timing specifications are shown as the following table and timing diagram.

| Signal                         | Item                        | Symbol | Min. | Typ. | Max. | Unit | Note       |
|--------------------------------|-----------------------------|--------|------|------|------|------|------------|
| LVDS Receiver Clock            | Frequency                   | 1/Tc   | (60) | 74   | (80) | MHz  | -          |
|                                | Input cycle to cycle jitter | Trcl   | -    | -    | 200  | ps   | -          |
| LVDS Receiver Data             | Setup Time                  | Tlvsu  | 600  | -    | -    | ps   | -          |
|                                | Hold Time                   | Tlvhd  | 600  | -    | -    | ps   | -          |
| Vertical Active Display Term   | Frame Rate                  | Fr5    | 47   | 50   | 53   | Hz   | (1)        |
|                                |                             | Fr6    | 57   | 60   | 63   | Hz   | (1)        |
|                                | Total                       | Tv     | 1115 | 1125 | 1135 | Th   | Tv=Tvd+Tvb |
|                                | Display                     | Tvd    | 1080 | 1080 | 1080 | Th   | -          |
|                                | Blank                       | Tvb    | 35   | 45   | 55   | Th   | -          |
| Horizontal Active Display Term | Total                       | Th     | 1050 | 1100 | 1150 | Tc   | Th=Thd+Thb |
|                                | Display                     | Thd    | 960  | 960  | 960  | Tc   | -          |
|                                | Blank                       | Thb    | 90   | 140  | 190  | Tc   | -          |

Note (1) (ODSEL) = (H), (L). Please refer to 5.1 for detail information.

Note (2) Since the module is operated in DE only mode, Hsync and Vsync input signals should be set to low logic level. Otherwise, this module would operate abnormally.

#### INPUT SIGNAL TIMING DIAGRAM

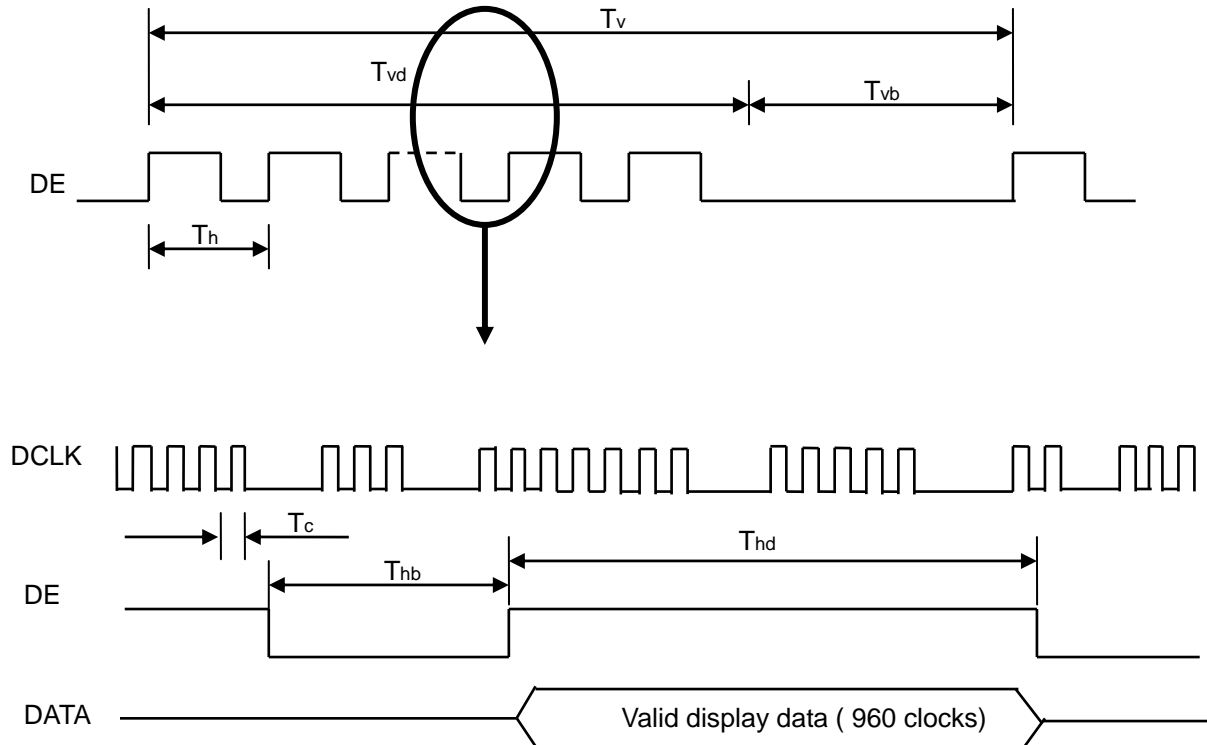

**LVDS INPUT INTERFACE TIMING DIAGRAM**

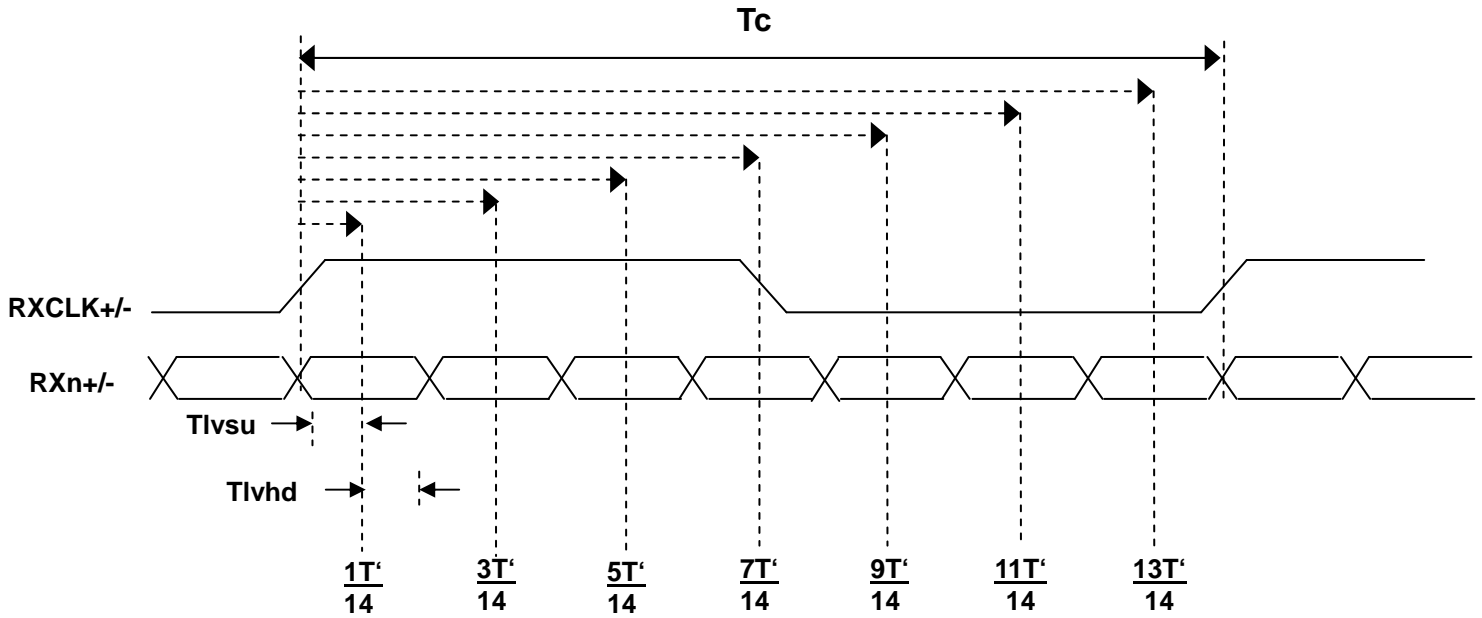



## 6.2 POWER ON/OFF SEQUENCE

To prevent a latch-up or DC operation of LCD module, the power on/off sequence should follow the diagram below.

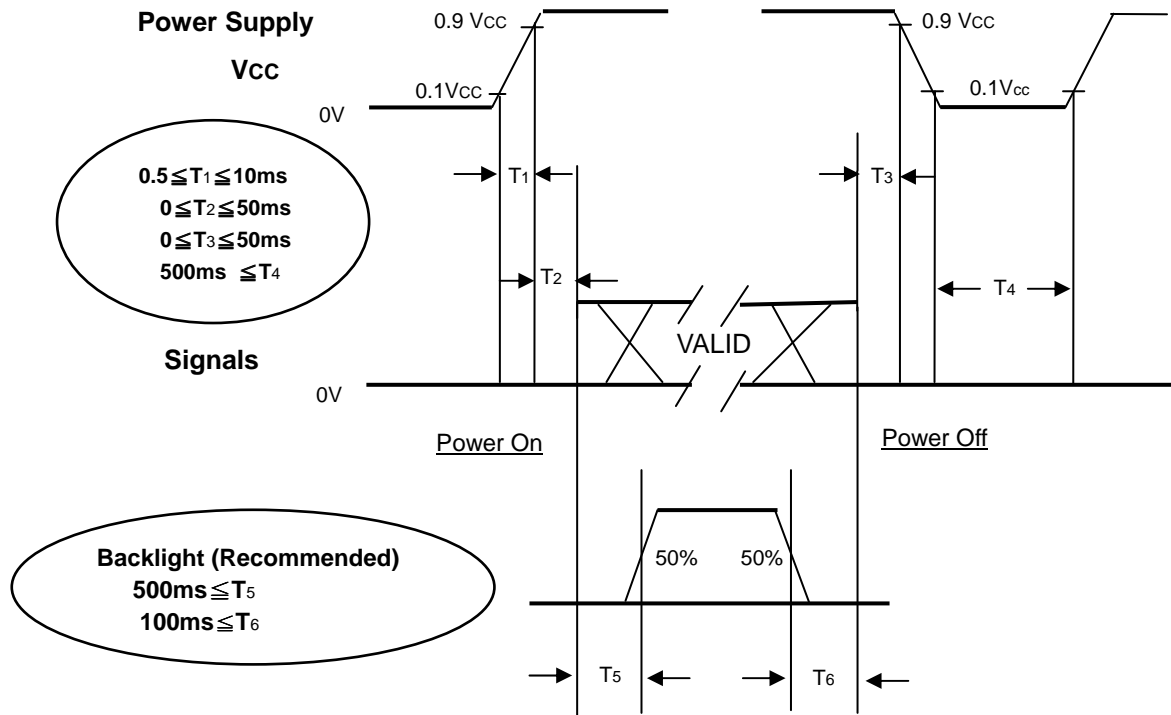

**Power ON/OFF Sequence**

Note :

- (1) The supply voltage of the external system for the module input should follow the definition of Vcc.
- (2) Apply the lamp voltage within the LCD operation range. When the backlight turns on before the LCD operation or the LCD turns off before the backlight turns off, the display may momentarily become abnormal screen.
- (3) In case of VCC is in off level, please keep the level of input signals on the low or high impedance.
- (4) T4 should be measured after the module has been fully discharged between power off and on period.
- (5) Interface signal shall not be kept at high impedance when the power is on.

## 7. OPTICAL CHARACTERISTICS

### 7.1 TEST CONDITIONS

| Item                             | Symbol  | Value   | Unit |
|----------------------------------|---|---------|------|
| Ambient Temperature              | Ta  | 25±2    | °C   |
| Ambient Humidity                 | Ha  | 50±10   | %RH  |
| Supply Voltage                   | V <sub>CC</sub>   | 12V     | V    |
| Input Signal                     | According to typical value in "3. ELECTRICAL CHARACTERISTICS" |         |      |
| Lamp Current                     | I <sub>L</sub>  | 6.0±0.5 | mA   |
| Oscillating Frequency (Inverter) | F <sub>W</sub>  | 48±3    | KHz  |
| Vertical Frame Rate              | Fr  | 60      | Hz   |

### 7.2 OPTICAL SPECIFICATIONS

The relative measurement methods of optical characteristics are shown in 7.2. The following items should be measured under the test conditions described in 7.1 and stable environment shown in Note (6).

| Item                      |            | Symbol         | Condition   | Min.          | Typ.          | Max.  | Unit              | Note     |          |
|---------------------------|------------|----------------|---|---------------|---------------|-------|-------------------|----------|----------|
| Contrast Ratio            |            | CR             | $\theta_x=0^\circ, \theta_y=0^\circ$<br>Viewing angle at normal direction | 3000          | 4000          | -     | -                 | Note (2) |          |
| Response Time             |            | Gray to gray   |   | -             | 6.5           | 12    | ms                | Note (3) |          |
| Center Luminance of White |            | L <sub>C</sub> |   | 450           | 500           | -     | cd/m <sup>2</sup> | Note (4) |          |
| White Variation           |            | $\delta W$     |   | -             | -             | 1.3   | -                 | Note (7) |          |
| Cross Talk                |            | CT             |   | -             | -             | 4     | %                 | Note (5) |          |
| Color Chromaticity        | Red        | R <sub>x</sub> |   | Typ.-<br>0.03 | Typ.+<br>0.03 | 0.643 | -                 | -        | Note (6) |
|                           |            | R <sub>y</sub> |   |               |               | 0.334 |                   |          |          |
|                           | Green      | G <sub>x</sub> |   |               |               | 0.266 |                   |          |          |
|                           |            | G <sub>y</sub> |   |               |               | 0.607 |                   |          |          |
|                           | Blue       | B <sub>x</sub> |   |               |               | 0.150 |                   |          |          |
|                           |            | B <sub>y</sub> | 0.060   |               |               |       |                   |          |          |
|                           | White      | W <sub>x</sub> | 0.285   |               |               |       |                   |          |          |
|                           |            | W <sub>y</sub> | 0.290   |               |               |       |                   |          |          |
| Color Gamut               |            |                | 72  | -             | %             | NTSC  |                   |          |          |
| Viewing Angle             | Horizontal | $\theta_{x+}$  | CR≥20   | 80            | 88            | -     | Deg.              | Note (1) |          |
|                           |            | $\theta_{x-}$  |   | 80            | 88            | -     |                   |          |          |
|                           | Vertical   | $\theta_{y+}$  |   | 80            | 88            | -     |                   |          |          |
|                           |            | $\theta_{y-}$  |   | 80            | 88            | -     |                   |          |          |

Note (1) Definition of Viewing Angle ( $\theta_x, \theta_y$ ):

Viewing angles are measured by Eldim EZ-Contrast 160R

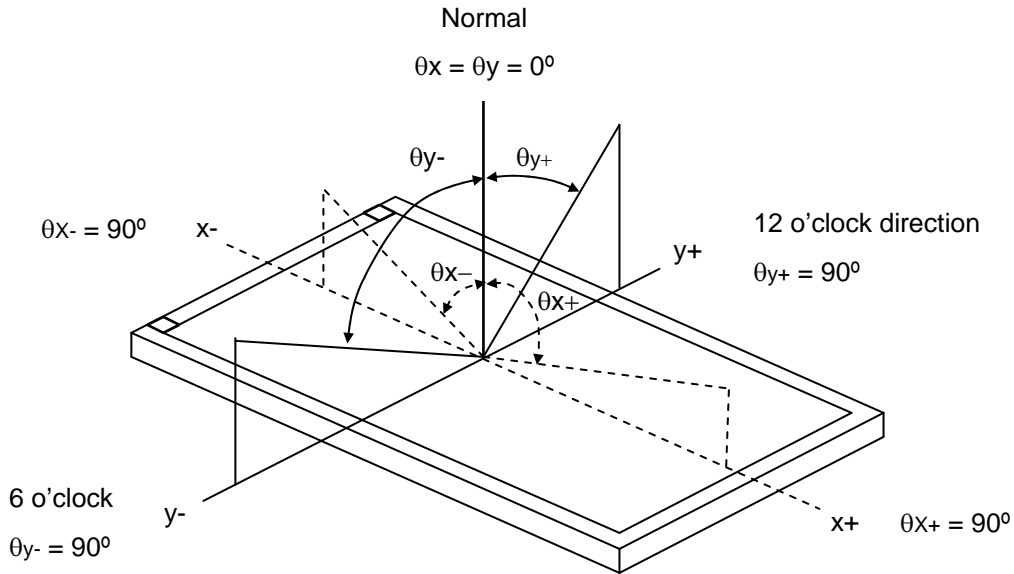

Note (2) Definition of Contrast Ratio (CR):

The contrast ratio can be calculated by the following expression.

$$\text{Contrast Ratio (CR)} = L_{255} / L_0$$

L255: Luminance of gray level 255

L 0: Luminance of gray level 0

CR = CR (5), where CR (X) is corresponding to the Contrast Ratio of the point X at the figure in Note (7)

Note (3) Definition of Gray to Gray Switching Time :

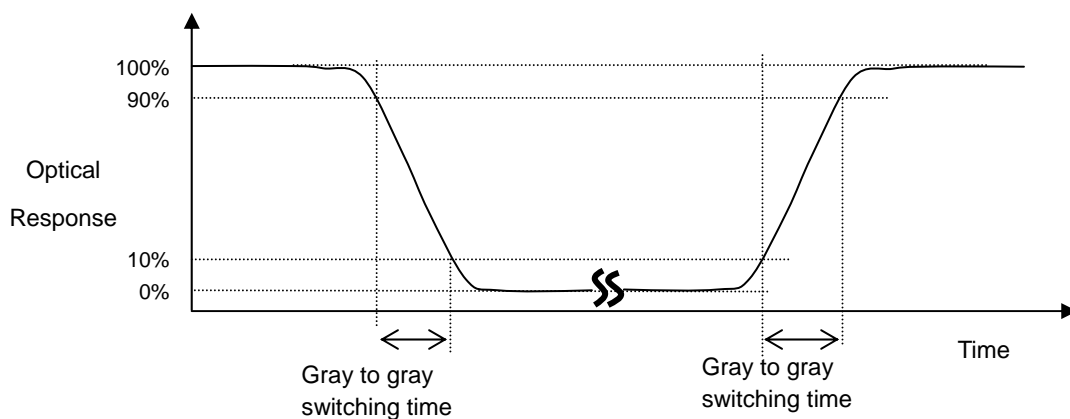

The driving signal means the signal of gray level 0, 63, 127, 191, and 255.

Gray to gray average time means the average switching time of gray level 0, 63, 127, 191, 255 to each other .

Note (4) Definition of Luminance of White ( $L_C$ ):

Measure the luminance of gray level 255 at center point.

$L_C = L(5)$ , where  $L(x)$  is corresponding to the luminance of the point X at the figure in Note (7).

Note (5) Definition of Cross Talk (CT):

$$CT = |Y_B - Y_A| / Y_A \times 100 (\%)$$

Where:

$Y_A$  = Luminance of measured location without gray level 255 pattern ( $\text{cd/m}^2$ )

$Y_B$  = Luminance of measured location with gray level 255 pattern ( $\text{cd/m}^2$ )

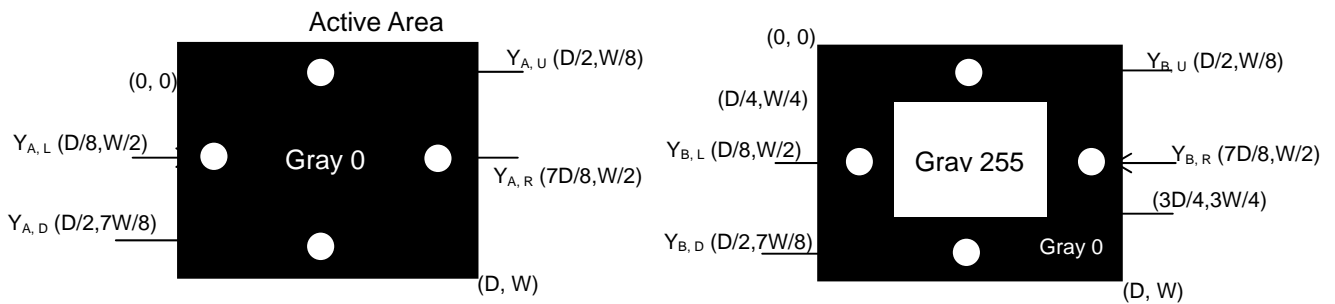

Note (6) Measurement Setup:

The LCD module should be stabilized at given temperature for 1 hour to avoid abrupt temperature change during measuring. In order to stabilize the luminance, the measurement should be executed after lighting backlight for 1 hour in a windless room.

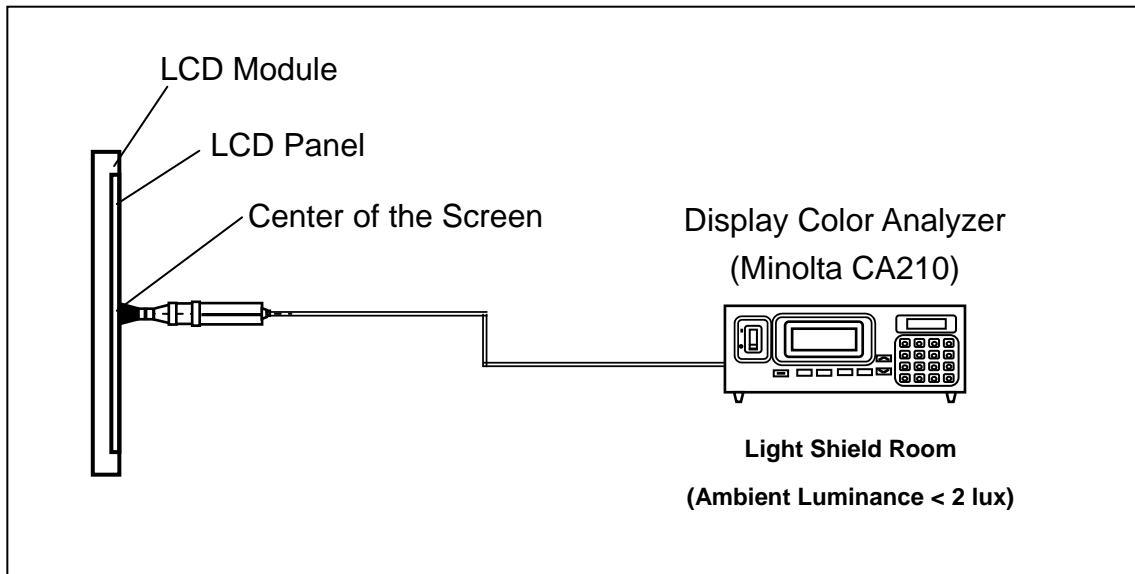

Note (7) Definition of White Variation ( $\delta W$ ):

Measure the luminance of gray level 255 at 5 points

$$\delta W = \text{Maximum} [L (1), L (2), L (3), L (4), L (5)] / \text{Minimum} [L (1), L (2), L (3), L (4), L (5)]$$

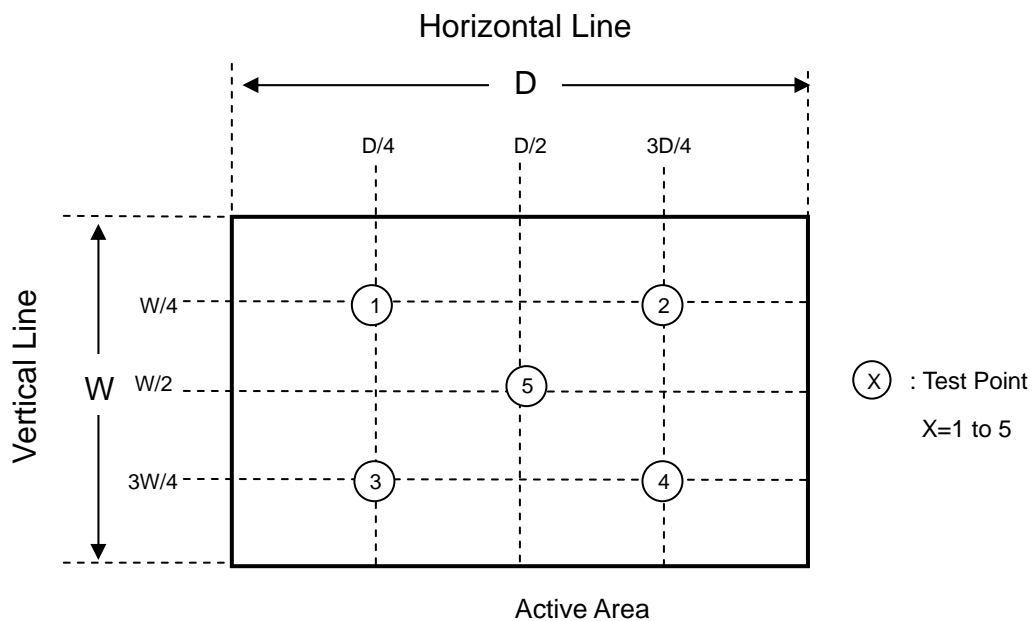

## 8. DEFINITION OF LABELS

### 8.1 CMO MODULE LABEL

The barcode nameplate is pasted on each module as illustration, and its definitions are as following explanation.

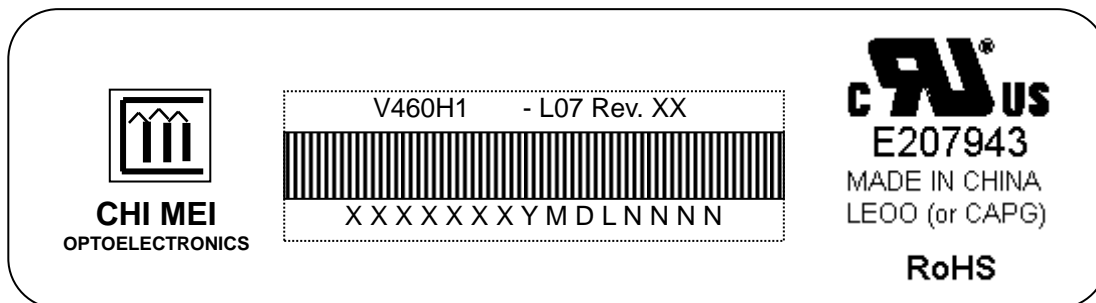

- (a) Model Name: V460H1-L07
- (b) Revision: Rev. XX, for example: A0, A1... B1, B2... or C1, C2...etc.
- (c) CMO barcode definition:

Serial ID: XX-XX-X-XX-YMD-L-NNNN

| Code | Meaning          | Description   |
|------|------------------|---|
| XX   | CMO internal use | -   |
| XX   | Revision         | Cover all the change  |
| X-XX | CMO internal use | -   |
| YMD  | Year, month, day | Year: 2001=1, 2002=2, 2003=3, 2004=4...<br>Month: Jan. ~ Dec.=1, 2, 3, ~, 9, A, B, C<br>Day: 1 <sup>st</sup> to 31 <sup>st</sup> =1, 2, 3, ~, 9, A, B, C, ~, W, X, Y, exclude I, O, and U |
| L    | Product line #   | Line 1=1, Line 2=2, Line 3=3, ...   |
| NNNN | Serial number    | Manufacturing sequence of product   |

## 9. PACKAGING

### 9.1 PACKING SPECIFICATIONS

- (1) 3 LCD TV modules / 1 Box
- (2) Box dimensions : 1190(L)x280(W)x712(H)mm
- (3) Weight : approximately 50Kg (3 modules per box)

### 9.2 PACKING METHOD

Figures 9-1 and 9-2 are the packing method

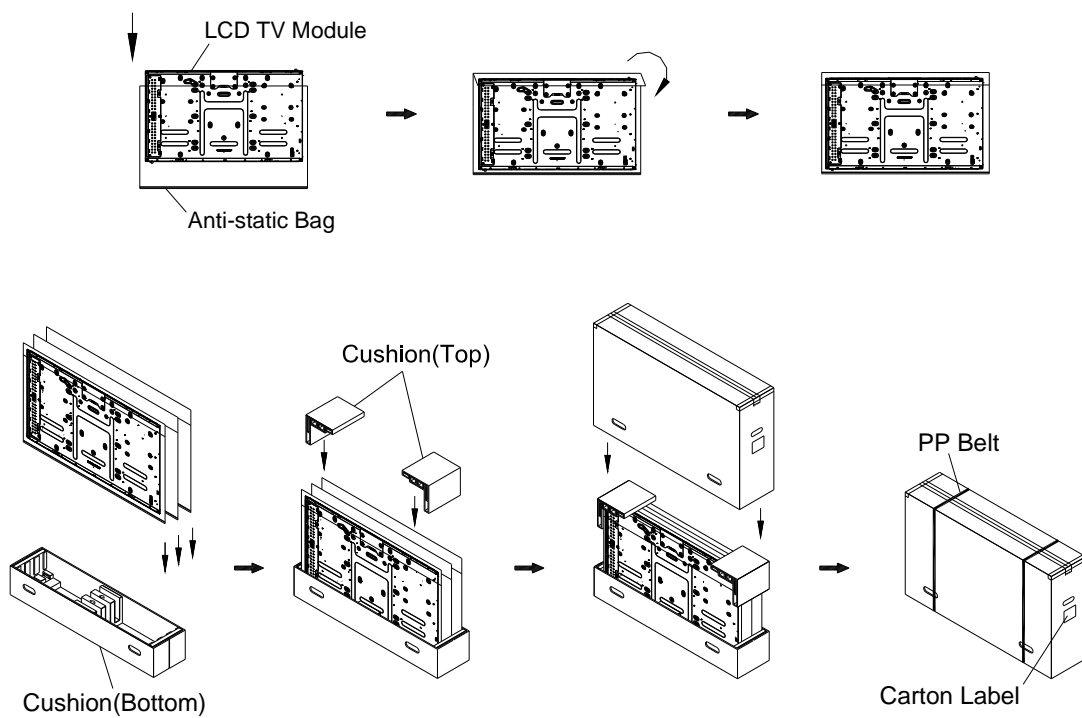
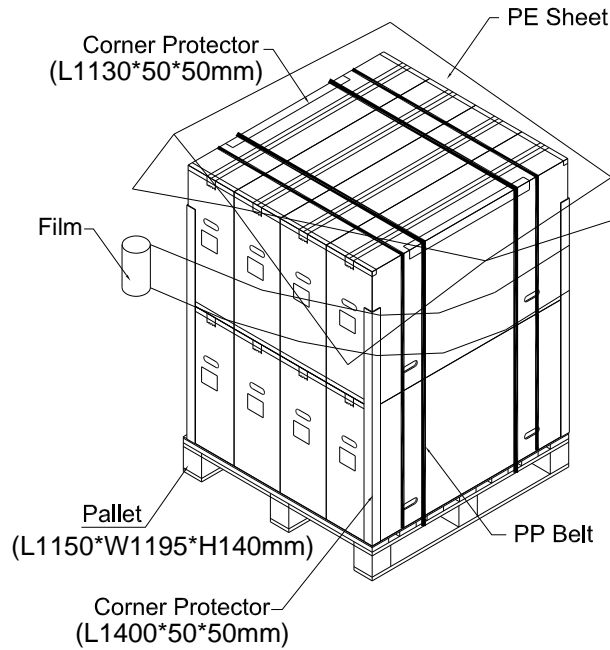

Figure.9-1 packing method

Air Transportation &  
Sea / Land Transportation (40ft Container)



Sea / Land Transportation (40ft HQ Container)

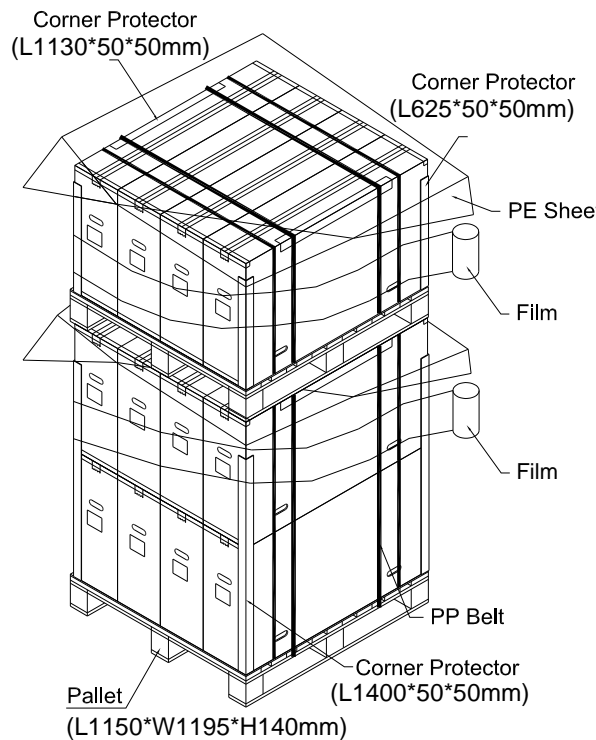

Figure.9-2 packing method



## 10. PRECAUTIONS

### 10.1 ASSEMBLY AND HANDLING PRECAUTIONS

- (1) Do not apply rough force such as bending or twisting to the module during assembly.
- (2) It is recommended to assemble or to install a module into the user's system in clean working areas. The dust and oil may cause electrical short or worsen the polarizer.
- (3) Do not apply pressure or impulse to the module to prevent the damage of LCD panel and backlight.
- (4) Always follow the correct power-on sequence when the LCD module is turned on. This can prevent the damage and latch-up of the CMOS LSI chips.
- (5) Do not plug in or pull out the I/F connector while the module is in operation.
- (6) Do not disassemble the module.
- (7) Use a soft dry cloth without chemicals for cleaning, because the surface of polarizer is very soft and easily scratched.
- (8) Moisture can easily penetrate into LCD module and may cause the damage during operation.
- (9) High temperature or humidity may deteriorate the performance of LCD module. Please store LCD modules in the specified storage conditions.
- (10) When ambient temperature is lower than 10°C, the display quality might be reduced. For example, the response time will become slow, and the starting voltage of CCFL will be higher than that of room temperature.

### 10.2 SAFETY PRECAUTIONS

- (1) The startup voltage of a backlight is over 1000 Volts. It may cause an electrical shock while assembling with the inverter. Do not disassemble the module or insert anything into the backlight unit.
- (2) If the liquid crystal material leaks from the panel, it should be kept away from the eyes or mouth. In case of contact with hands, skin or clothes, it has to be washed away thoroughly with soap.
- (3) After the module's end of life, it is not harmful in case of normal operation and storage.

### 10.3 SAFETY STANDARDS

The LCD module should be certified with safety regulations as follows:

| Regulatory                       | Item | Standard                    |
|----------------------------------|------|-----------------------------|
| Information Technology equipment | UL   | UL 60950-1: 2003            |
|                                  | cUL  | CAN/CSA C22.2 No.60950-1-03 |
|                                  | CB   | IEC 60950-1:2001            |
| Audio/Video Apparatus            | UL   | UL 60065: 2003              |
|                                  | cUL  | CAN/CSA C22.2 No.60065-03   |
|                                  | CB   | IEC 60065:2001              |





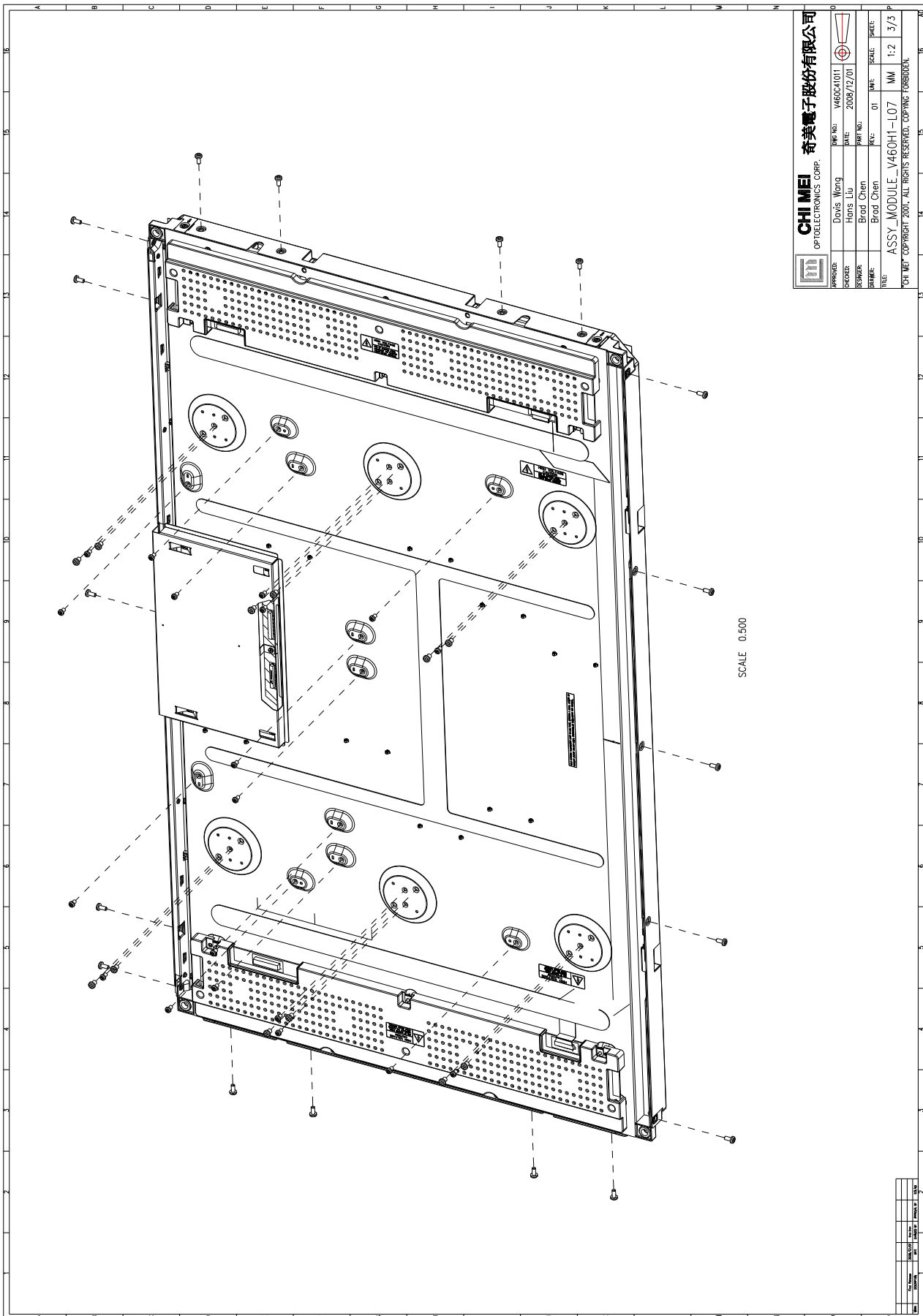

|   |                         |                   |            |
|---|-------------------------|-------------------|------------|
| <b>CHI MEI</b><br>OPTOELECTRONICS CORP.                         |                         | <b>奇美電子股份有限公司</b> |            |
| APPROVER:   | DAVIS HANG              | DWG. NO.:         | V460C21011 |
| DESIGNER:   | HONG LIU                | DATE:             | 2008/12/01 |
| ENGINEER:   | BROD CHEN               | PART. NO.:        |            |
| DRAWER:   | BROD CHEN               | REV.:             | 01         |
| TITLE:  | ASSY. MODULE V460H1-L07 | SCALE:            | SHEET      |
|   |                         | MM                | 1:2        |
|   |                         |                   | 3/3        |
| CHI MEI COPYRIGHT 2007. ALL RIGHTS RESERVED. COPYING FORBIDDEN. |                         |                   |            |