

- Tentative Specification
- Preliminary Specification
- Approval Specification

**MODEL NO.: V460H1**  
**SUFFIX: LE5**

<b>Customer:</b>	
<b>APPROVED BY</b>	<b>SIGNATURE</b>
Name / Title _____	_____
<b>Note</b>	
_____	
Please return 1 copy for your confirmation with your	

Approved By	Checked By	Prepared By
Chao-Chun Chung	Ken Wu	HT Hung

## CONTENTS

1. GENERAL DESCRIPTION.....	5
1.1 OVERVIEW.....	5
1.2 FEATURES.....	5
1.3 APPLICATION.....	5
1.4 GENERAL SPECIFICATIONS.....	5
1.5 MECHANICAL SPECIFICATIONS.....	6
2. ABSOLUTE MAXIMUM RATINGS.....	7
2.1 ABSOLUTE RATINGS OF ENVIRONMENT.....	7
2.2 PACKAGE STORAGE.....	8
2.3 ELECTRICAL ABSOLUTE RATINGS.....	8
2.3.1 TFT LCD MODULE.....	8
2.3.2 BACKLIGHT UNIT.....	8
3. ELECTRICAL CHARACTERISTICS.....	9
3.1 TFT LCD MODULE.....	9
3.2 BACKLIGHT UNIT.....	12
3.2.1 LED LIGHT BAR CHARACTERISTICS (Ta =25 °C, Initial Turn on).....	12
4. BLOCK DIAGRAM OF INTERFACE.....	13
4.1 TFT LCD MODULE.....	13
5. INPUT TERMINAL PIN ASSIGNMENT.....	14
5.1 TFT LCD.....	14
5.2 BACKLIGHT UNIT.....	16
5.3 BLOCK DIAGRAM OF INTERFACE.....	17
5.4 LVDS INTERFACE.....	18
5.5 COLOR DATA INPUT ASSIGNMENT.....	19
5.6 FLICKER (Vcom) ADJUSTMENT.....	20
6. INTERFACE TIMING.....	21
6.1 INPUT SIGNAL TIMING SPECIFICATIONS.....	21
6.2 POWER ON/OFF SEQUENCE.....	24
7. OPTICAL CHARACTERISTICS.....	25
7.1 TEST CONDITIONS.....	25
7.2 OPTICAL SPECIFICATIONS.....	26

8. PRECAUTIONS .....	31
8.1 ASSEMBLY AND HANDLING PRECAUTIONS .....	31
8.2 SAFETY PRECAUTIONS .....	31
9. DEFINITION OF LABELS.....	32
9.1 CMI MODULE LABEL.....	32
10. PACKAGING .....	33
10.1 PACKAGING SPECIFICATIONS .....	33
10.2 PACKAGING METHOD .....	33
11. MECHANICAL CHARACTERISTIC.....	35

## REVISION HISTORY

Version	Date	Page(New)	Section	Description
Ver. 2.0	Jan. 31, 2011	All	All	The approval specification was first issued.

## 1. GENERAL DESCRIPTION

### 1.1 OVERVIEW

V460H1-LE5 is a 46" TFT Liquid Crystal Display module with LED Backlight unit and 2ch-LVDS interface. This module supports 1920 x 1080 Full HDTV format and can display 1G colors (8-bit+hi-FRC). The converter module for backlight isn't built-in.

### 1.2 FEATURES

- High brightness (450 nits)
- High contrast ratio (5000:1)
- Fast response time (Gray to gray average 6.5 ms)
- High color saturation (NTSC 72%)
- Full HDTV (1920 x 1080 pixels) resolution, true HDTV format
- DE (Data Enable) only mode
- LVDS (Low Voltage Differential Signaling) interface
- Optimized response time for 120 Hz frame rate
- Ultra wide viewing angle : Super MVA technology
- RoHs compliance

### 1.3 APPLICATION

- Standard Living Room TVs
- Public Display Application
- Home Theater Application
- MFM Application

### 1.4 GENERAL SPECIFICATIONS

Item	Specification	Unit	Note
Active Area	1018.08(H) x 572.67 (V) (46" diagonal)	mm	(1)
Bezel Opening Area	1024.9(H) x 579.3 (V)	mm	
Driver Element	a-si TFT active matrix	-	-
Pixel Number	1920 x R.G.B. x 1080	pixel	-
Pixel Pitch(Sub Pixel)	0.17675 (H) x 0.53025 (V)	mm	-
Pixel Arrangement	RGB vertical stripe	-	-
Power consumption	98.84W (LVDS input Power 16.44W + LED Backlight Power 82.4W)	Watt	(2)
Display Colors	1G	color	-
Display Operation Mode	Transmissive mode / Normally Black	-	-
Surface Treatment	Anti-Glare coating (Haze 11%)	-	(3)

Note (1) Please refer to the attached drawings in chapter 11 for more information about the front and back outlines.

Note (2) Please refer to sec 3.1 and 3.2 for more information of power consumption.

## 1.5 MECHANICAL SPECIFICATIONS

Item		Min.	Typ.	Max.	Unit	Note
Module Size	Horizontal (H)	1055.9	1056.9	1057.9	mm	(1)
	Vertical (V)	611.3	612.3	613.3	mm	
	Depth (D)	23.5	24.5	25.5	mm	(2)
Weight		-	9500	-		-

Note (1) Please refer to the attached drawings in chapter 11 for more information of front and back outline dimensions.

Note (2) Module Depth is between bezel to T-CON cover.

## 2. ABSOLUTE MAXIMUM RATINGS

### 2.1 ABSOLUTE RATINGS OF ENVIRONMENT

Item	Symbol	Value		Unit	Note
		Min.	Max.		
Storage Temperature	TST	-20	+60	°C	(1)
Operating Ambient Temperature	TOP	0	50	°C	(1), (2)
Shock (Non-Operating)	SNOP	-	50	G	(3), (5)
Vibration (Non-Operating)	VNOP	-	1.0	G	(4), (5)

Note (1) Temperature and relative humidity range is shown in the figure below.

(a) 90 %RH Max. ( $T_a \leq 40$  °C).

(b) Wet-bulb temperature should be 39 °C Max. ( $T_a > 40$  °C).

(c) No condensation.

Note (2) The maximum operating temperature is based on the test condition that the surface temperature of display area is less than or equal to 65 °C with LCD module alone in a temperature controlled chamber. Thermal management should be considered in final product design to prevent the surface temperature of display area from being over 65 °C. The range of operating temperature may degrade in case of improper thermal management in final product design.

Note (3) 11 ms, half sine wave, 1 time for  $\pm X$ ,  $\pm Y$ ,  $\pm Z$ .

Note (4) 10 ~ 200 Hz, 10 min, 1 time each X, Y, Z.

Note (5) At testing Vibration and Shock, the fixture in holding the module has to be hard and rigid enough so that the module would not be twisted or bent by the fixture.

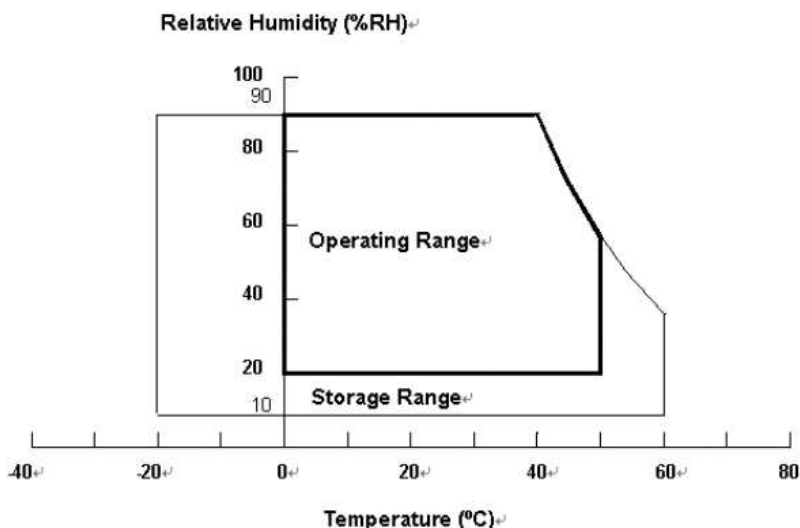

## 2.2 PACKAGE STORAGE

When storing modules as spares for a long time, the following precaution is necessary.

- (a) Do not leave the module in high temperature, and high humidity for a long time, It is highly recommended to store the module with temperature from 0 to 35 °C at normal humidity without condensation.
- (b) The module shall be stored in dark place. Do not store the TFT-LCD module in direct sunlight or fluorescent light.

## 2.3 ELECTRICAL ABSOLUTE RATINGS

### 2.3.1 TFT LCD MODULE

Item	Symbol	Value		Unit	Note
		Min.	Max.		
Power Supply Voltage	VCC	-0.3	13.5	V	
Logic Input Voltage	VIN	-0.3	3.6	V	

### 2.3.2 BACKLIGHT UNIT

Item	Symbol	Value		Unit	Note
		Min.	Max.		
Light bar Voltage	VW	—	187	V <sub>DC</sub>	(1)

Note (1) The light bar voltage specification is specified by ROE.



## 3. ELECTRICAL CHARACTERISTICS

### 3.1 TFT LCD MODULE

(Ta = 25 ± 2 °C)

Parameter		Symbol	Value			Unit	Note
			Min.	Typ.	Max.		
Power Supply Voltage		V <sub>CC</sub>	10.8	12	13.2	V	(1)
Rush Current		I <sub>RUSH</sub>	—	—	5	A	(2)
Power consumption	White Pattern	P <sub>T</sub>	—	8.712	—	W	(3)
	Black Pattern	P <sub>T</sub>	—	8.58	14.4	W	
	Horizontal Stripe	P <sub>T</sub>	—	13.2	16.44	W	
Power Supply Current	White Pattern	—	—	0.726	—	A	(3)
	Black Pattern	—	—	0.715	1.2	A	
	Horizontal Stripe	—	—	1.1	1.37	A	
LVDS interface	Differential Input High Threshold Voltage	V <sub>LVTH</sub>	+100	—	—	mV	(4)
	Differential Input Low Threshold Voltage	V <sub>LVTL</sub>	—	—	-100	mV	
	Common Input Voltage	V <sub>CM</sub>	1.0	1.2	1.4	V	
	Differential input voltage (single-end)	V <sub>ID</sub>	200	—	600	mV	
	Terminating Resistor	R <sub>T</sub>	—	100	—	ohm	
CMIS interface	Input High Threshold Voltage	V <sub>IH</sub>	2.7	—	3.3	V	
	Input Low Threshold Voltage	V <sub>IL</sub>	0	—	0.7	V	

Note (1) The module should be always operated within the above ranges.

Note (2) Measurement condition:

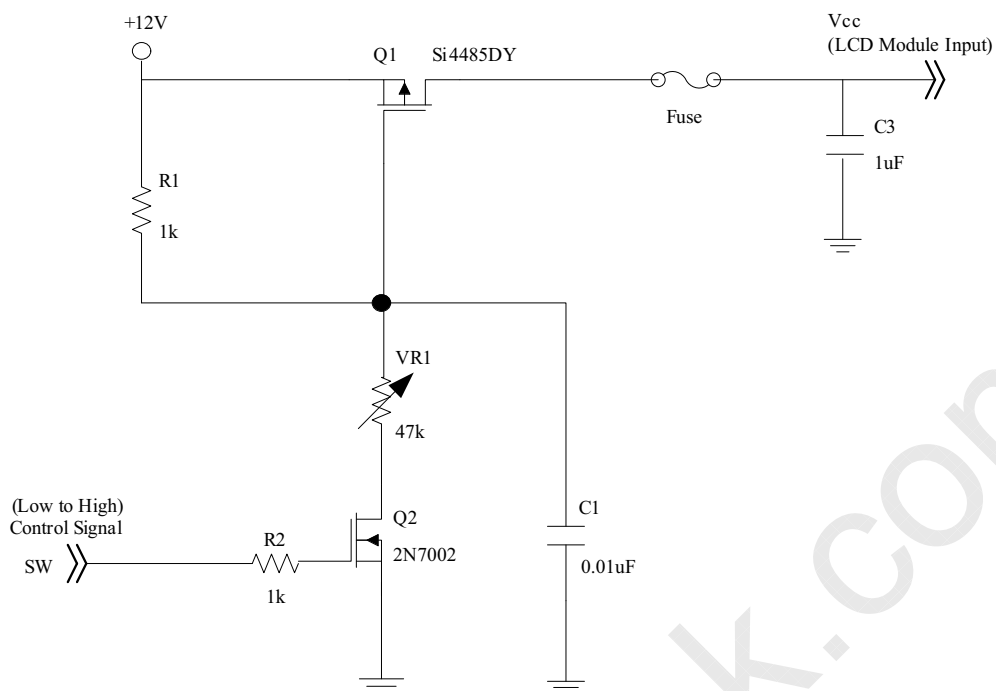

**Vcc rising time is 470us**

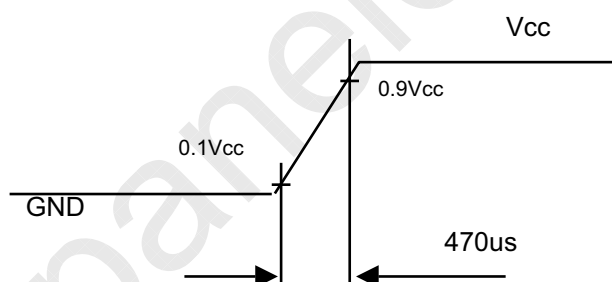

Note (3) The specified power supply current and power consumption is under the conditions at  $V_{cc} = 12\text{ V}$ ,  $T_a = 25 \pm 2\text{ }^\circ\text{C}$ ,  $f_v = 120\text{ Hz}$ , whereas a power dissipation check pattern below is displayed.

a. White Pattern



Active Area

b. Black Pattern



Active Area

c. Horizontal Pattern

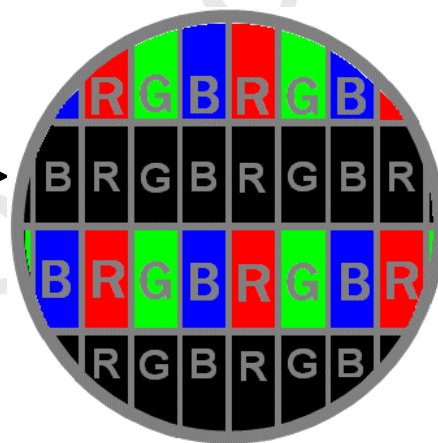
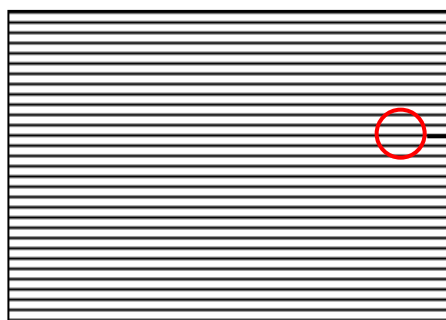

Note (4) The LVDS input characteristics are as follows :

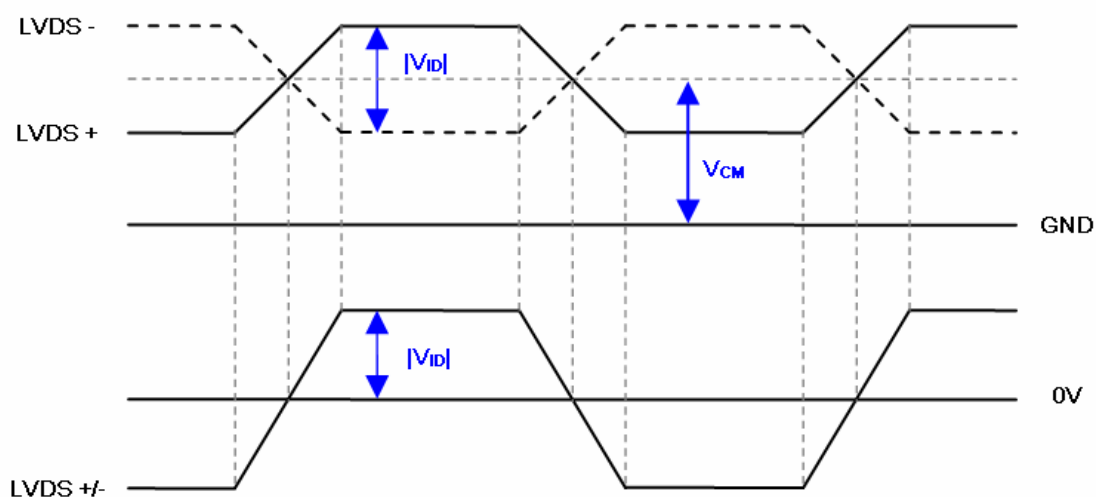

## 3.2 BACKLIGHT UNIT

### 3.2.1 LED LIGHT BAR CHARACTERISTICS (Ta =25 °C, Initial Turn on)

The backlight unit contains 4pcs light bar.

Parameter	Symbol	Value			Unit	Note
		Min.	Typ.	Max.		
Total Current (4 String)	I <sub>f</sub>	-	480	-	mA	(1) Duty=100%, I <sub>PIN</sub> =120mA
One String Current	I <sub>L</sub>	-	120	-	mA	(1) Duty=100%
One String Voltage	V <sub>w</sub>	159.4	-	175.7	V <sub>DC</sub>	@120mA, only LEDs
Power consumption	P <sub>BL</sub>	76.5	-	84.3	W	only LEDs Duty=100%, I <sub>PIN</sub> =120mA
Deviation of One String Voltage	ΔV <sub>w</sub>	-	-	13	V	@120mA, only LEDs

Note (1) The LED light bar characteristics is specified by ROE.

## 4. BLOCK DIAGRAM OF INTERFACE

### 4.1 TFT LCD MODULE

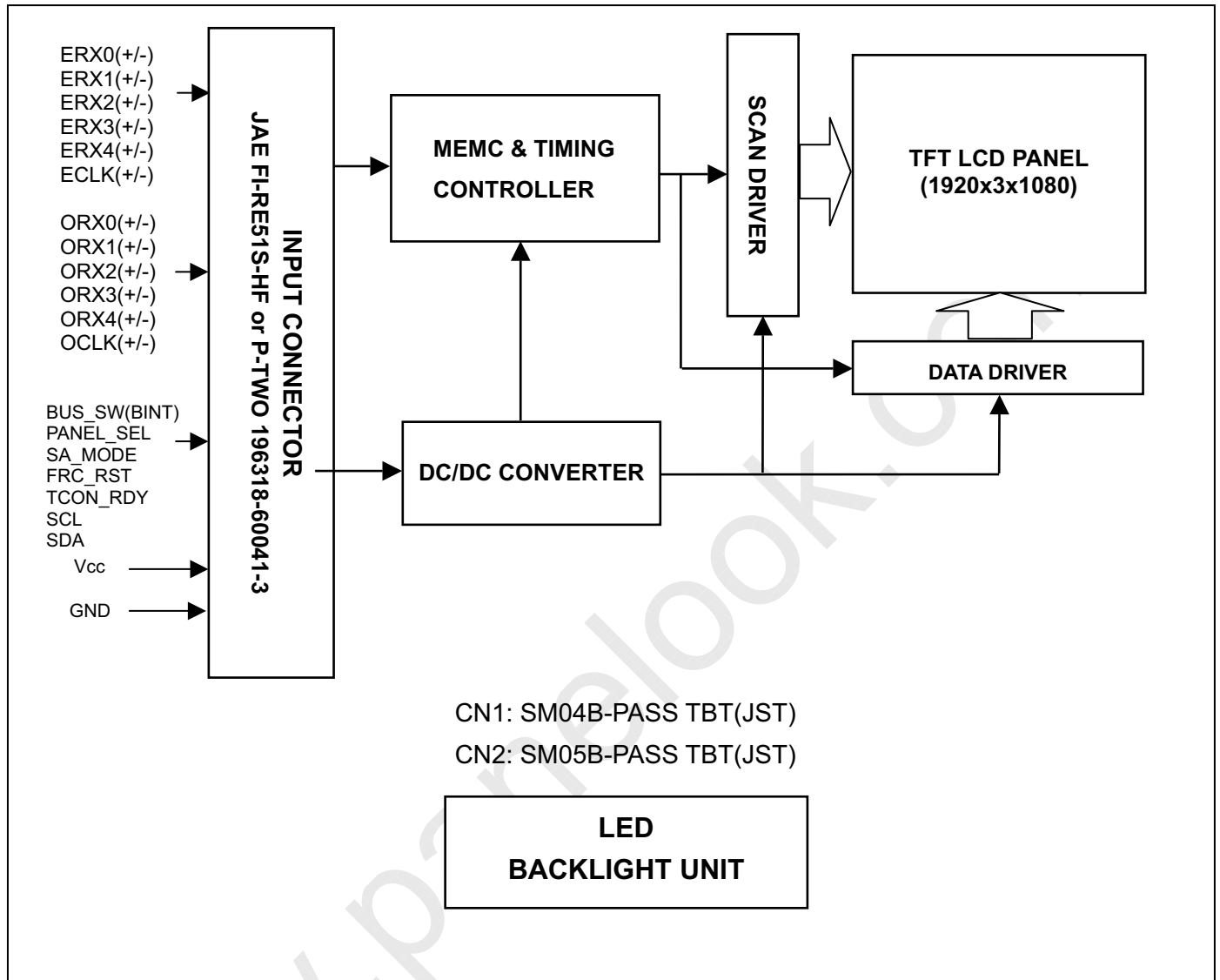

## 5. INPUT TERMINAL PIN ASSIGNMENT

### 5.1 TFT LCD

Pin	Name	Description	Note
1	VCC	+12V power supply	
2	VCC	+12V power supply	
3	VCC	+12V power supply	
4	VCC	+12V power supply	
5	VCC	+12V power supply	
6	N.C.	No Connection	
7	GND	Ground	
8	GND	Ground	
9	GND	Ground	
10	ORX0-	Odd pixel Negative LVDS differential data input. Channel 0	(1)
11	ORX0+	Odd pixel Positive LVDS differential data input. Channel 0	
12	ORX1-	Odd pixel Negative LVDS differential data input. Channel 1	
13	ORX1+	Odd pixel Positive LVDS differential data input. Channel 1	
14	ORX2-	Odd pixel Negative LVDS differential data input. Channel 2	
15	ORX2+	Odd pixel Positive LVDS differential data input. Channel 2	
16	GND	Ground	
17	OCLK-	Odd pixel Negative LVDS differential clock input	(1)
18	OCLK+	Odd pixel Positive LVDS differential clock input.	
19	GND	Ground	
20	ORX3-	Odd pixel Negative LVDS differential data input. Channel 3	(1)
21	ORX3+	Odd pixel Positive LVDS differential data input. Channel 3	
22	ORX4-	Odd pixel Negative LVDS differential data input. Channel 4	
23	ORX4+	Odd pixel Positive LVDS differential data input. Channel 4	
24	GND	Ground	
25	ERX0-	Even pixel Negative LVDS differential data input. Channel 0	(1)
26	ERX0+	Even pixel Positive LVDS differential data input. Channel 0	
27	ERX1-	Even pixel Negative LVDS differential data input. Channel 1	
28	ERX1+	Even pixel Positive LVDS differential data input. Channel 1	
29	ERX2-	Even pixel Negative LVDS differential data input. Channel 2	
30	ERX2+	Even pixel Positive LVDS differential data input. Channel 2	
31	GND	Ground	
32	ECLK-	Even pixel Negative LVDS differential clock input.	(1)
33	ECLK+	Even pixel Positive LVDS differential clock input.	
34	GND	Ground	
35	ERX3-	Even pixel Negative LVDS differential data input. Channel 3	(1)
36	ERX3+	Even pixel Positive LVDS differential data input. Channel 3	
37	ERX4-	Even pixel Negative LVDS differential data input. Channel 4	
38	ERX4+	Even pixel Positive LVDS differential data input. Channel 4	
39	GND	Ground	
40	SCL	EEPROM Serial Clock (for auto Vcom)	
41	SDA	EEPROM Serial Data (for auto Vcom)	
42	REV	Sony Reserved pin	(4)
43	BUS_SW	BUS_SW/BINT, Sony Reserved pin.	
44	Panel_SEL	Internal no connection, Sony Reserved pin.	
45	REV	Sony Reserved pin	
46	SA_MODE	CXD4730GB Standalone Mode input, Sony Reserved pin.	
47	REV	Sony Reserved pin	
48	FRC_RST	Internal no connection, Sony Reserved pin.	(4)
49	REV	Sony Reserved pin	
50	TCON_RDY	Internal no connection, Sony Reserved pin.	

51	WP	EEPROM Write Protection (for auto Vcom) (0V~0.7V→Disable, 2.7V~3.3V→Enable)	(3)
----	----	--	-----

Note (1) Two pixel data send into the module for every clock cycle. The first pixel of the frame is odd pixel and the second pixel is even pixel

Note (2) LVDS connector pin order defined as follows

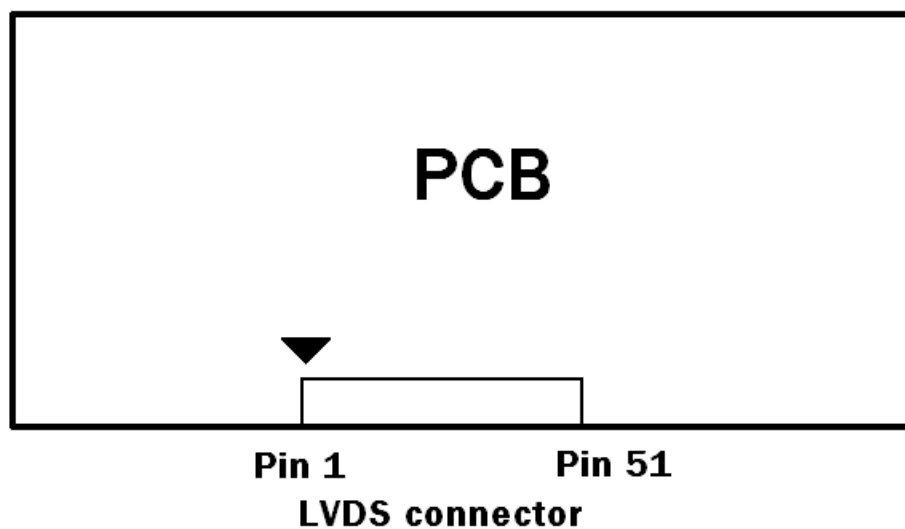

Note (3) Digital auto VCOM adjust control pin.

WP	Mode
L(default)	Internal weak pull-low
H	Auto-VCOM adjust mode.

Note (4) Sony reserved pin for Sony system use. Please leave it open.

Note (5) The screw hole which is distant from the connector is merged with Ground

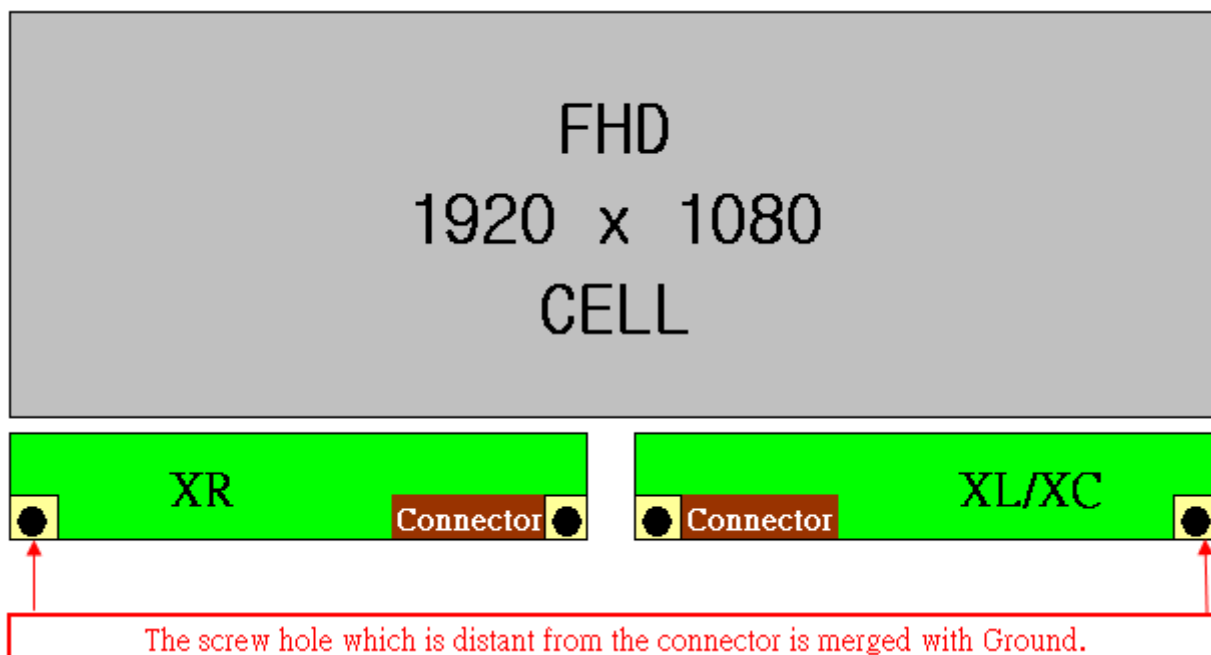

## 5.2 BACKLIGHT UNIT

The pin configuration for the housing and the leader wire is shown in the table below:

CN1: SM04B-PASS TBT(JST) or equivalent

Pin No.	Symbol	Feature
1	+OUT1	Positive of LED String
2	+OUT2	Positive of LED String
3	+OUT3	Positive of LED String
4	+OUT4	Positive of LED String

CN2: SM05B-PASS TBT(JST) or equivalent

Pin No.	Symbol	Feature
1	-OUT1	Negative of LED String
2	-OUT2	Negative of LED String
3	NC	NC
4	-OUT3	Negative of LED String
5	-OUT4	Negative of LED String



## 5.3 BLOCK DIAGRAM OF INTERFACE

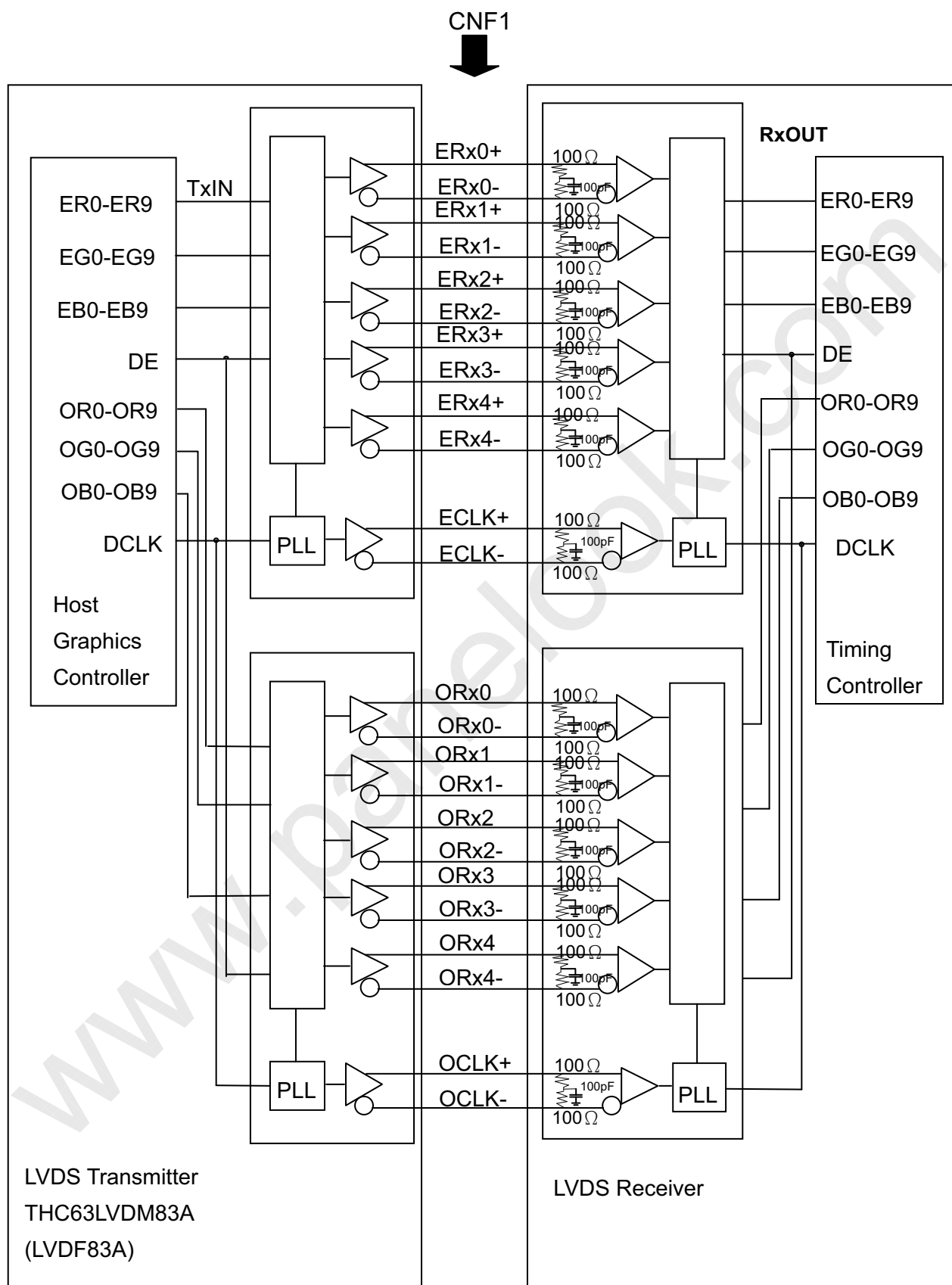

**5.4 LVDS INTERFACE**

JEDIA LVDS format :

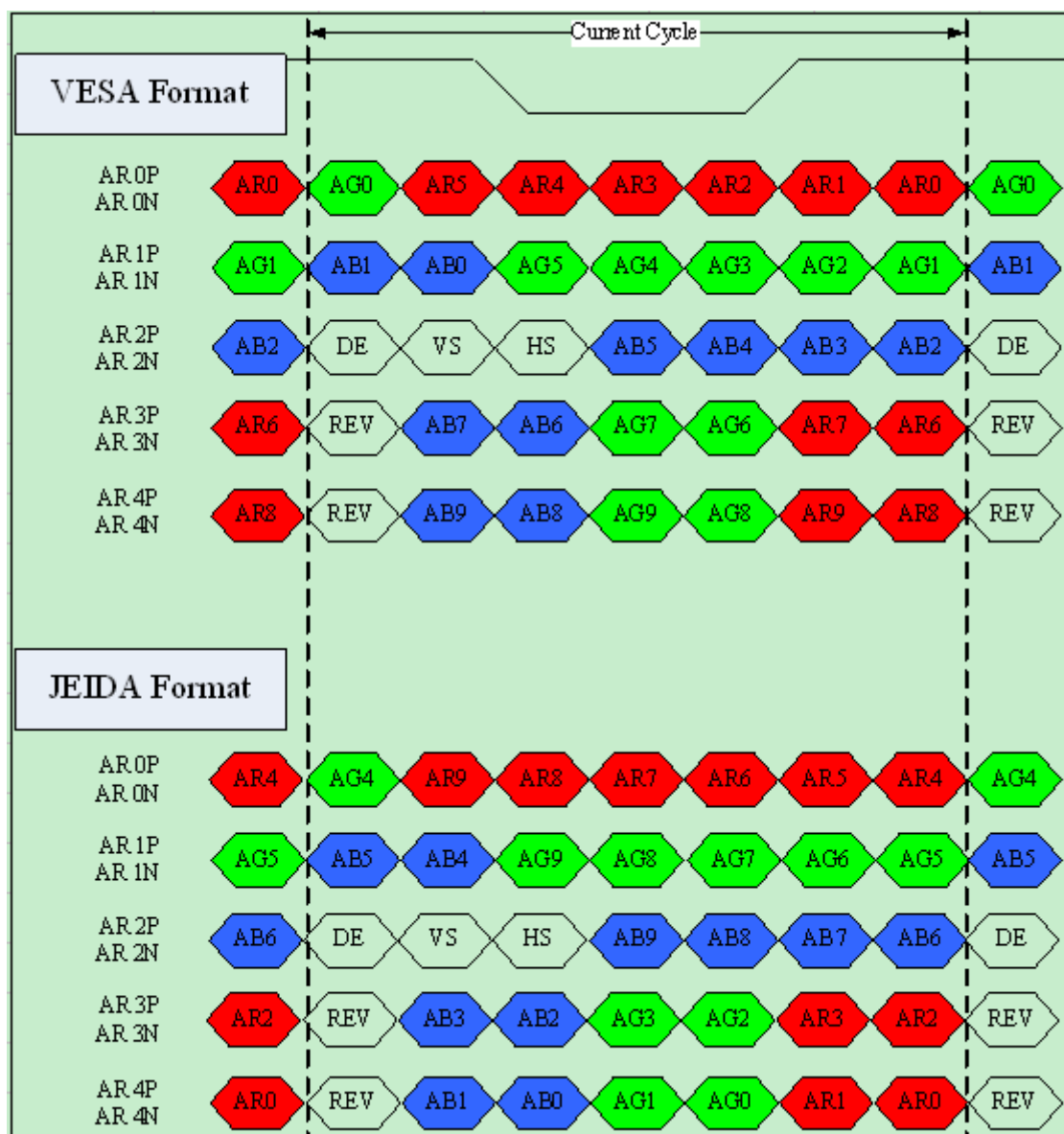

R0~R9: Pixel R Data (9; MSB, 0; LSB)

G0~G9: Pixel G Data (9; MSB, 0; LSB)

B0~B9: Pixel B Data (9; MSB, 0; LSB)

DE : Data enable signal

DCLK : Data clock signal

Notes: (1) RSVD (reserved) pins on the transmitter shall be "H" or "L".



# PRODUCT SPECIFICATION

## 5.5 COLOR DATA INPUT ASSIGNMENT

The brightness of each primary color (red, green and blue) is based on the 10-bit gray scale data input for the color. The higher the binary input the brighter the color. The table below provides the assignment of color versus data input.

Color		Data Signal																																						
		Red										Green						Blue																						
		R9	R8	R7	R6	R5	R4	R3	R2	R1	R0	G9	G8	G7	G6	G5	G4	G3	G2	G1	G0	B9	B8	B7	B6	B5	B4	B3	B2	B1	B0									
Basic Colors	Black	0	0	0	0	0	0	0	0	0	0	0	0	0	0	0	0	0	0	0	0	0	0	0	0	0	0	0	0	0	0	0	0	0	0	0	0	0	0	0
	Red	1	1	1	1	1	1	1	1	1	1	0	0	0	0	0	0	0	0	0	0	0	0	0	0	0	0	0	0	0	0	0	0	0	0	0	0	0	0	0
	Green	0	0	0	0	0	0	0	0	0	0	0	1	1	1	1	1	1	1	1	0	0	0	0	0	0	0	0	0	0	0	0	0	0	0	0	0	0	0	0
	Blue	0	0	0	0	0	0	0	0	0	0	0	0	0	0	0	0	0	0	0	0	0	0	0	0	0	0	0	0	0	1	1	1	1	1	1	1	1	1	1
	Cyan	0	0	0	0	0	0	0	0	0	0	0	1	1	1	1	1	1	1	1	1	1	1	1	1	1	1	1	1	1	0	0	0	0	0	0	0	0	0	0
	Magenta	1	1	1	1	1	1	1	1	1	1	0	0	0	0	0	0	0	0	0	0	0	0	0	0	0	0	0	0	0	1	1	1	1	1	1	1	1	1	1
	Yellow	1	1	1	1	1	1	1	1	1	1	1	1	1	1	1	1	1	1	1	1	1	1	1	1	1	1	1	1	1	0	0	0	0	0	0	0	0	0	0
	White	1	1	1	1	1	1	1	1	1	1	1	1	1	1	1	1	1	1	1	1	1	1	1	1	1	1	1	1	1	1	1	1	1	1	1	1	1	1	1
Gray Scale Of Red	Red (0) / Dark	0	0	0	0	0	0	0	0	0	0	0	0	0	0	0	0	0	0	0	0	0	0	0	0	0	0	0	0	0	0	0	0	0	0	0	0	0	0	
	Red (1)	0	0	0	0	0	0	0	0	0	1	0	0	0	0	0	0	0	0	0	0	0	0	0	0	0	0	0	0	0	0	0	0	0	0	0	0	0	0	
	Red (2)	0	0	0	0	0	0	0	0	0	1	0	0	0	0	0	0	0	0	0	0	0	0	0	0	0	0	0	0	0	0	0	0	0	0	0	0	0	0	
	⋮	⋮	⋮	⋮	⋮	⋮	⋮	⋮	⋮	⋮	⋮	⋮	⋮	⋮	⋮	⋮	⋮	⋮	⋮	⋮	⋮	⋮	⋮	⋮	⋮	⋮	⋮	⋮	⋮	⋮	⋮	⋮	⋮	⋮	⋮	⋮	⋮	⋮	⋮	
	Red (1021)	1	1	1	1	1	1	1	1	0	1	0	0	0	0	0	0	0	0	0	0	0	0	0	0	0	0	0	0	0	0	0	0	0	0	0	0	0	0	
	Red (1022)	1	1	1	1	1	1	1	1	1	0	0	0	0	0	0	0	0	0	0	0	0	0	0	0	0	0	0	0	0	0	0	0	0	0	0	0	0	0	
	Red (1023)	1	1	1	1	1	1	1	1	1	1	0	0	0	0	0	0	0	0	0	0	0	0	0	0	0	0	0	0	0	0	0	0	0	0	0	0	0	0	
Gray Scale Of Green	Green (0) / Dark	0	0	0	0	0	0	0	0	0	0	0	0	0	0	0	0	0	0	0	0	0	0	0	0	0	0	0	0	0	0	0	0	0	0	0	0	0	0	
	Green (1)	0	0	0	0	0	0	0	0	0	0	0	0	0	0	0	0	0	0	0	0	0	0	0	0	0	0	0	0	0	0	0	0	0	0	0	0	0	0	
	Green (2)	0	0	0	0	0	0	0	0	0	0	0	0	0	0	0	0	0	1	0	0	0	0	0	0	0	0	0	0	0	0	0	0	0	0	0	0	0	0	
	⋮	⋮	⋮	⋮	⋮	⋮	⋮	⋮	⋮	⋮	⋮	⋮	⋮	⋮	⋮	⋮	⋮	⋮	⋮	⋮	⋮	⋮	⋮	⋮	⋮	⋮	⋮	⋮	⋮	⋮	⋮	⋮	⋮	⋮	⋮	⋮	⋮	⋮	⋮	
	Green (1021)	0	0	0	0	0	0	0	0	0	0	1	1	1	1	1	1	1	0	1	0	0	0	0	0	0	0	0	0	0	0	0	0	0	0	0	0	0	0	
	Green (1022)	0	0	0	0	0	0	0	0	0	0	1	1	1	1	1	1	1	0	0	0	0	0	0	0	0	0	0	0	0	0	0	0	0	0	0	0	0	0	
	Green (1023)	0	0	0	0	0	0	0	0	0	0	1	1	1	1	1	1	1	1	0	0	0	0	0	0	0	0	0	0	0	0	0	0	0	0	0	0	0	0	
Gray Scale Of Blue	Blue (0) / Dark	0	0	0	0	0	0	0	0	0	0	0	0	0	0	0	0	0	0	0	0	0	0	0	0	0	0	0	0	0	0	0	0	0	0	0	0	0	0	
	Blue (1)	0	0	0	0	0	0	0	0	0	0	0	0	0	0	0	0	0	0	0	0	0	0	0	0	0	0	0	0	0	0	0	0	0	0	0	0	0	1	
	Blue (2)	0	0	0	0	0	0	0	0	0	0	0	0	0	0	0	0	0	0	0	0	0	0	0	0	0	0	0	0	0	0	0	0	0	0	0	0	0	1	
	⋮	⋮	⋮	⋮	⋮	⋮	⋮	⋮	⋮	⋮	⋮	⋮	⋮	⋮	⋮	⋮	⋮	⋮	⋮	⋮	⋮	⋮	⋮	⋮	⋮	⋮	⋮	⋮	⋮	⋮	⋮	⋮	⋮	⋮	⋮	⋮	⋮	⋮	⋮	
	Blue (1021)	0	0	0	0	0	0	0	0	0	0	0	0	0	0	0	0	0	0	0	1	1	1	1	1	1	1	1	1	1	1	1	1	1	1	1	0	1	1	
	Blue (1022)	0	0	0	0	0	0	0	0	0	0	0	0	0	0	0	0	0	0	0	1	1	1	1	1	1	1	1	1	1	1	1	1	1	1	1	1	1	0	
	Blue (1023)	0	0	0	0	0	0	0	0	0	0	0	0	0	0	0	0	0	0	0	1	1	1	1	1	1	1	1	1	1	1	1	1	1	1	1	1	1	1	

Note (1) 0: Low Level Voltage, 1: High Level Voltage

## 5.6 FLICKER (Vcom) ADJUSTMENT

### (1) Adjustment Pattern:

2n+1 line-inversion pattern was shown as below. If customer need below pattern, please directly contact with Account FAE.

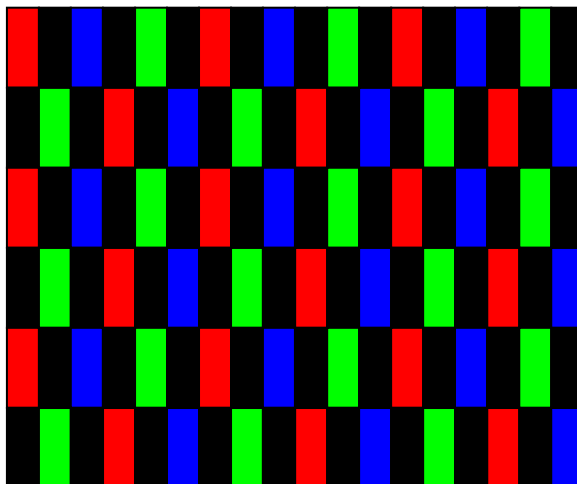

### (2) Adjustment method: (Digital V-com)

Programmable memory IC is used for Digital V-com adjustment in this model. CMI provide Auto Vcom tools to adjust Digital V-com. The detail connection and setting instruction, please directly contact with Account FAE or refer CMI Auto V-com adjustment OI. Below items is suggested to be ready before Digital V-com adjustment in customer LCM line.

- a. USB Sensor Board
- b. Programmable software.

## 6. INTERFACE TIMING

### 6.1 INPUT SIGNAL TIMING SPECIFICATIONS

(Ta = 25 ± 2 °C)

The input signal timing specifications are shown as the following table and timing diagram.

Signal	Item	Symbol	Min.	Typ.	Max.	Unit	Note
LVDS Receiver Clock	Frequency	$F_{clk_{in}}$ (=1/TC)	60	75	79	MHz	
	Input cycle to cycle jitter	$T_{rcj}$	—	—	200	ps	(3)
	Spread spectrum modulation range	$F_{clk_{in\_mod}}$	$F_{clk_{in}}-2\%$	—	$F_{clk_{in}}+3\%$	MHz	(4)
	Spread spectrum modulation frequency	$F_{SSM}$	—	—	150	KHz	
LVDS Receiver Data	Receiver Skew Margin	$T_{RSKM}$	-400	—	400	ps	(5)
Vertical Active Display Term	Frame Rate	$F_{r5}$	47	50	53	Hz	(6)
		$F_{r6}$	57	60	63	Hz	
	Total	$T_v$	1115	1125	2046	Th	$T_v=T_{vd}+T_{vb}$
	Display	$T_{vd}$	1080	1080	1080	Th	—
	Blank	$T_{vb}$	35	45	966	Th	—
Horizontal Active Display Term	Total	$T_h$	1000	1104	2046	Tc	$T_h=T_{hd}+T_{hb}$
	Display	$T_{hd}$	960	960	960	Tc	—
	Blank	$T_{hb}$	40	144	1086	Tc	—

**Note (1)** Please make sure the range of pixel clock has follow the below equation :

$$F_{clk_{in}(max)} \geq F_{r6} \times T_v \times T_h$$

$$F_{r5} \times T_v \times T_h \geq F_{clk_{in}(min)}$$

Note (2) This module is operated in DE only mode and please follow the input signal timing diagram below :

### INPUT SIGNAL TIMING DIAGRAM

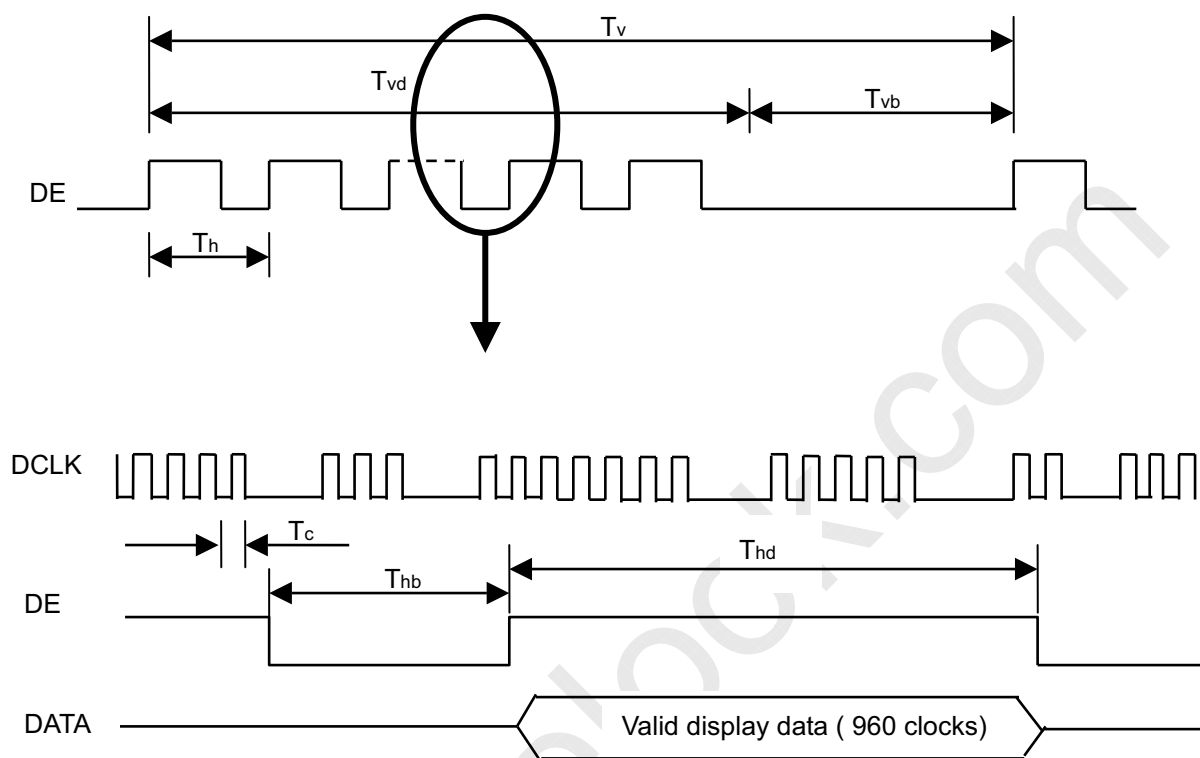

Note (3) The input clock cycle-to-cycle jitter is defined as below figures.  $Trcl = |T_1 - T_1|$

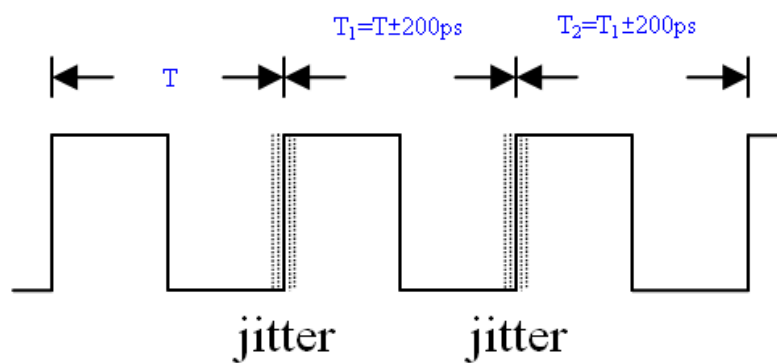

Note (4) The SSCG (Spread spectrum clock generator) is defined as below figures.

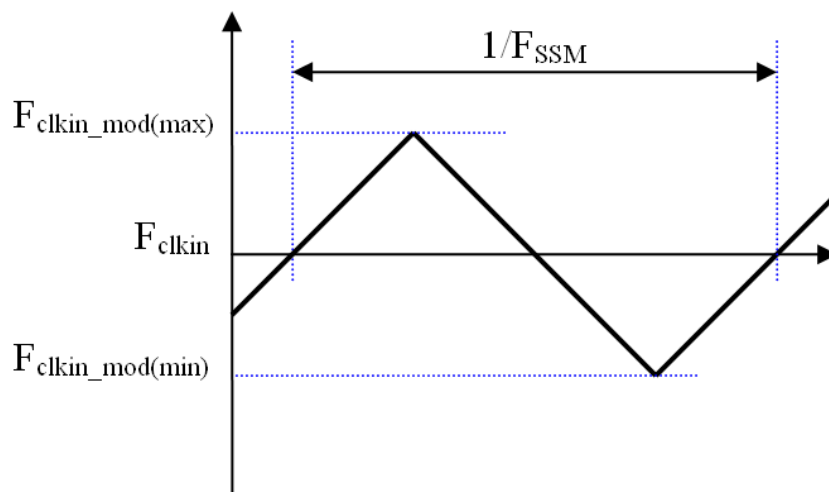

Note (5) The LVDS timing diagram and the time of receiver skew margin is defined and showing as the following figures.

#### LVDS RECEIVER INTERFACE TIMING DIAGRAM

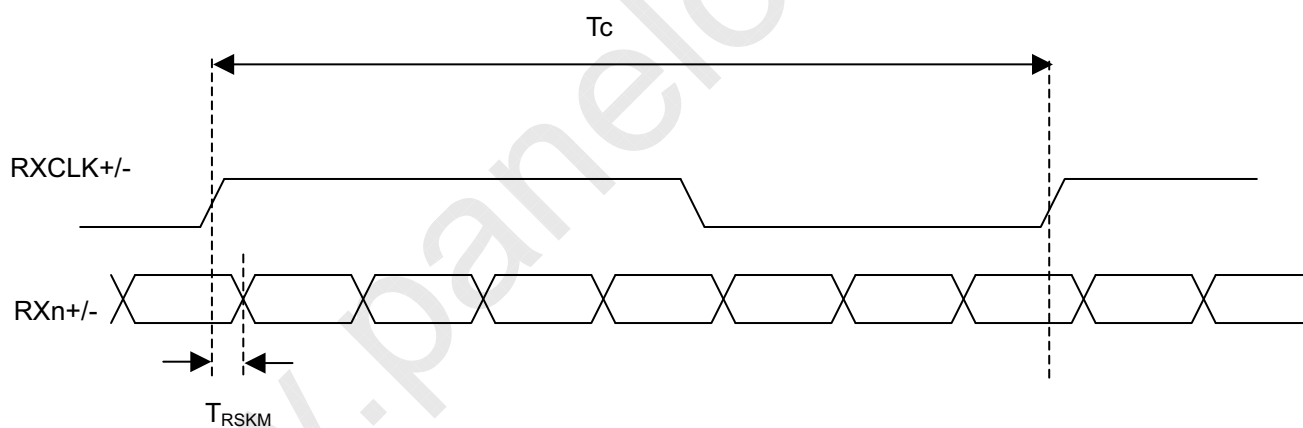

## 6.2 POWER ON/OFF SEQUENCE

( $T_a = 25 \pm 2 \text{ }^\circ\text{C}$ )

To prevent a latch-up or DC operation of LCD module, the power on/off sequence should be as the diagram below.

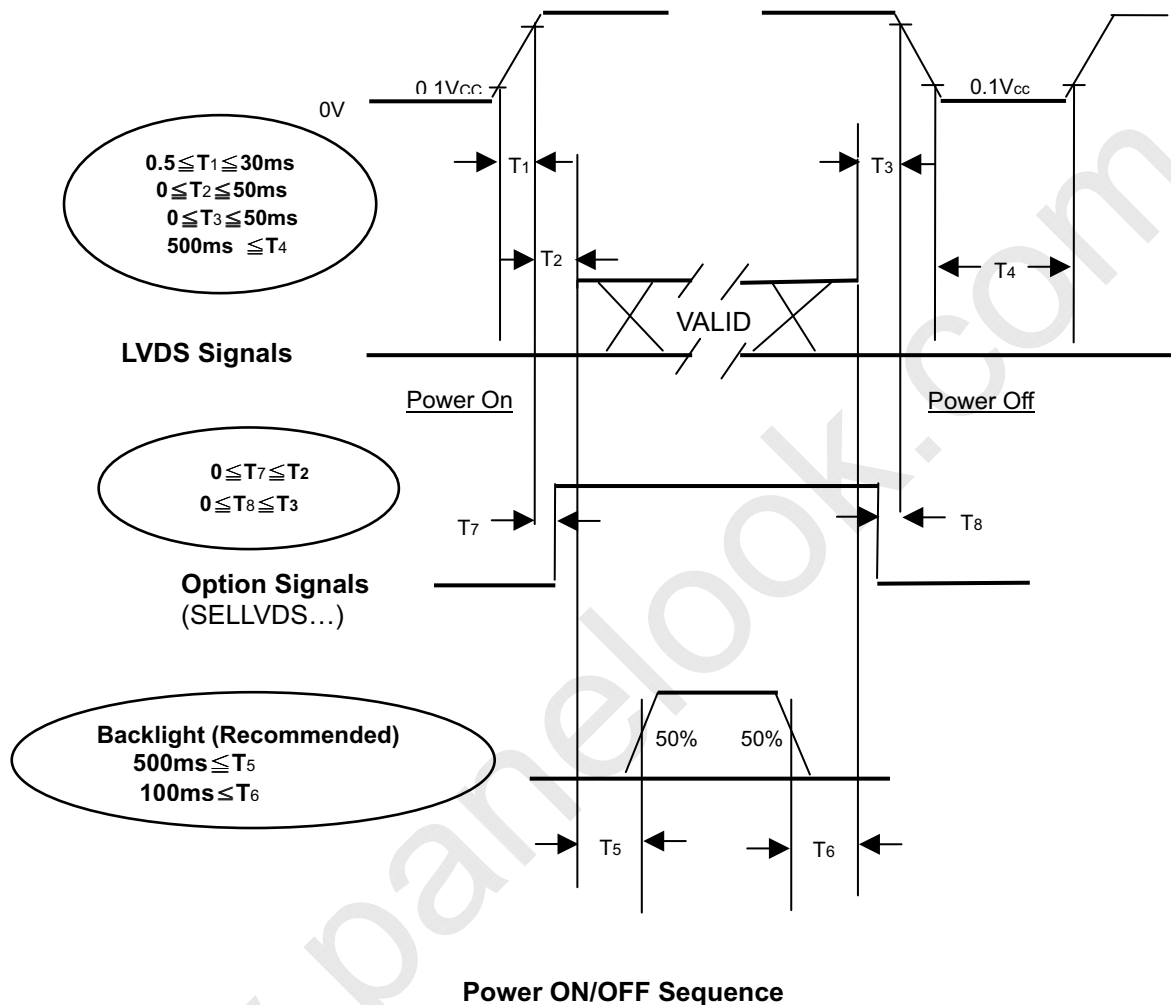

Note (1) The supply voltage of the external system for the module input should follow the definition of Vcc.

Note (2) Apply the lamp voltage within the LCD operation range. When the backlight turns on before the LCD operation or the LCD turns off before the backlight turns off, the display may momentarily become abnormal screen.

Note (3) In case of VCC is in off level, please keep the level of input signals on the low or high impedance.

Note (4) T4 should be measured after the module has been fully discharged between power off and on period.

Note (5) Interface signal shall not be kept at high impedance when the power is on.



**7. OPTICAL CHARACTERISTICS**
**7.1 TEST CONDITIONS**

Item	Symbol	Value	Unit
Ambient Temperature	Ta	25±2	°C
Ambient Humidity	Ha	50±10	%RH
Supply Voltage	V <sub>CC</sub>	12	V
Input Signal	According to typical value in "3. ELECTRICAL CHARACTERISTICS"		
LED Current	I <sub>L</sub>	120 ± 7.2	mA

The LCD module should be stabilized at given temperature for 1 hour to avoid abrupt temperature change during measuring in a windless room.

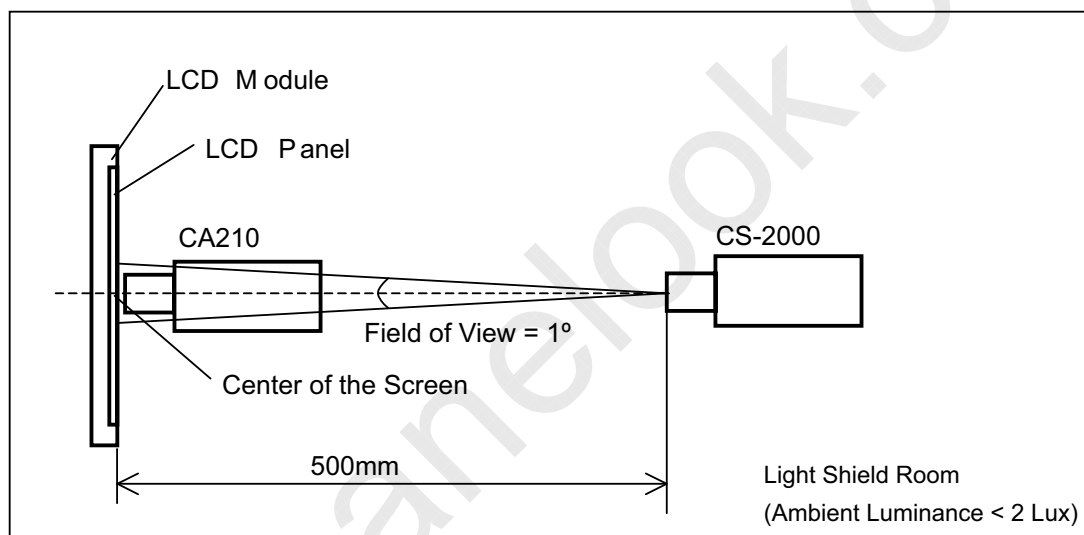

## 7.2 OPTICAL SPECIFICATIONS

The relative measurement methods of optical characteristics are shown in 7.2. The following items should be measured under the test conditions described in 7.1 and stable environment shown in 7.1.

Item		Symbol	Condition	Min.	Typ.	Max.	Unit	Note
Response Time	Gray to gray		$\theta_x=0^\circ, \theta_y=0^\circ$ Panel temperature is $32\pm 1^\circ\text{C}$	-	6.5	12	ms	(3)
		$T_R$		-	35	-	ms	
		$T_F$		-	4.5	-	ms	
Contrast Ratio		CR	$\theta_x=0^\circ, \theta_y=0^\circ$ Viewing angle at normal direction	3500	5000			(2)
Center Luminance of White		$L_C$		360	450	-	$\text{cd/m}^2$	(4)
White Variation		$\delta W$		-	-	1.30	-	(6)
Cross Talk		CT		-	-	4	%	(5)
Color Chromaticity	Red	$R_x$		Typ. -0.03	Typ. +0.03	0.645	-	-
		$R_y$				0.319	-	
	Green	$G_x$				0.288	-	
		$G_y$	0.633			-		
	Blue	$B_x$	0.155			-		
		$B_y$	0.043			-		
	White	$W_x$	0.280			-		
		$W_y$	0.285			-		
Color Gamut		C.G.	-	72	-	%	NTSC	
Viewing Angle	Horizontal	$\theta_{x+}$	CR $\geq$ 20	80	88	-	Deg.	(1)
		$\theta_{x-}$		80	88	-		
	Vertical	$\theta_{Y+}$		80	88	-		
		$\theta_{Y-}$		80	88	-		

Note (1) Definition of Viewing Angle ( $\theta_x$ ,  $\theta_y$ ) :

Viewing angles are measured by Autronic Conoscope Cono-80

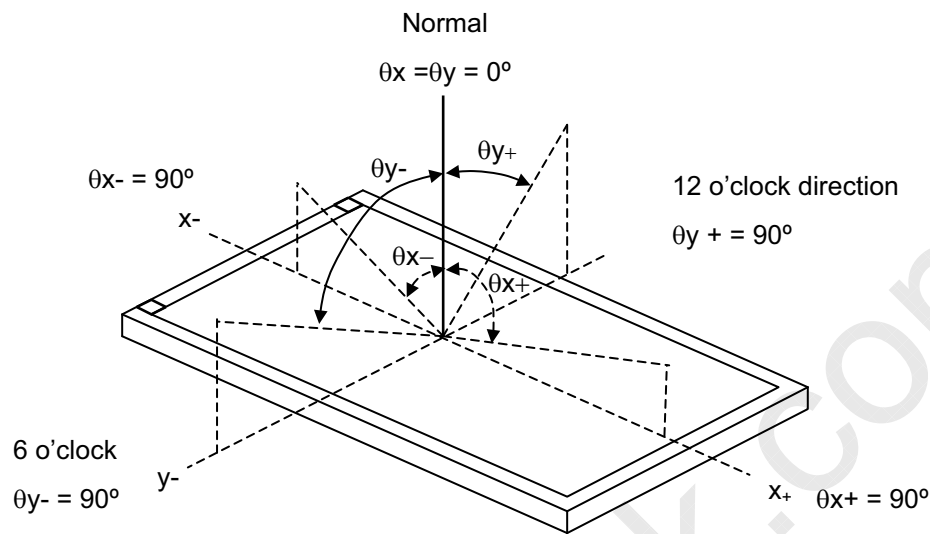

Note (2) Definition of Contrast Ratio (CR) :

The contrast ratio can be calculated by the following expression.

$$\text{Contrast Ratio (CR)} = \frac{\text{Surface Luminance of L255}}{\text{Surface Luminance of L0}}$$

L255: Luminance of gray level 255

L 0: Luminance of gray level 0

CR= CR (5), where CR (X) is corresponding to the Contrast Ratio of the point X at the figure in Note (6).

Note (3) Definition of Response Time ( $T_R$ ,  $T_F$ , Gray to Gray) :

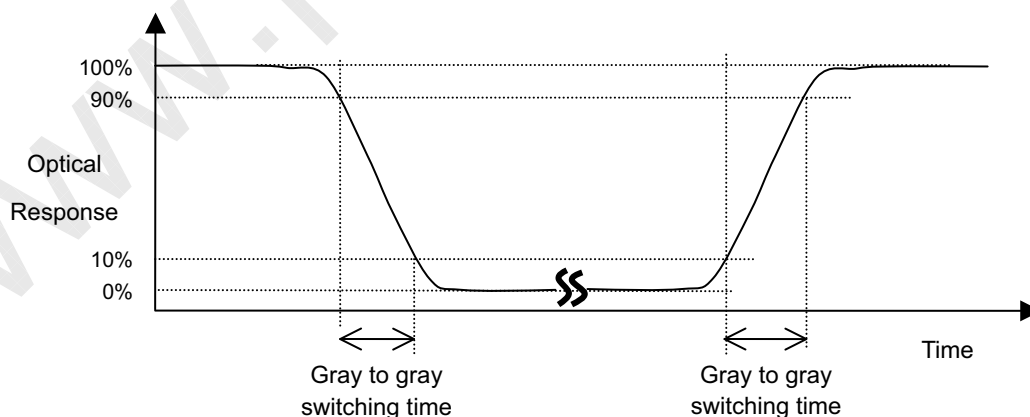

The driving signal means the signal of gray level 0, 31, 63, 95, 127, 159, 191, 223 and 255

$T_R$  means switching time from gray 0 to 255

$T_F$  means switching time from gray 255 to 0

Gray to gray means the average switching time of gray level 0, 31, 63, 95, 127, 159, 191, 223 and 255 to each other.

Note (4) Definition of Luminance of White ( $L_C$ ):

Measure the luminance of gray level 255 at center point and 5 points

$L_C = L(5)$ , where  $L(X)$  is corresponding to the luminance of the point X at the figure in Note (6).

Note (5) Definition of Cross Talk (CT):

$$CT = |Y_B - Y_A| / Y_A \times 100 (\%)$$

Where:

$Y_A$  = Luminance of measured location without gray level 0 pattern (cd/m<sup>2</sup>)

$Y_B$  = Luminance of measured location with gray level 0 pattern (cd/m<sup>2</sup>)

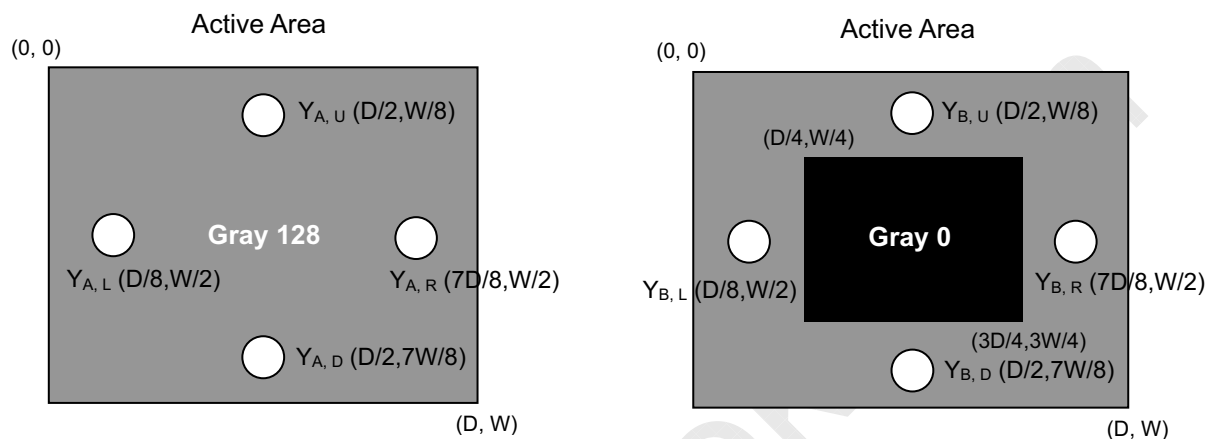

$Y_A$  = Luminance of measured location without gray level 255 pattern (cd/m<sup>2</sup>)

$Y_B$  = Luminance of measured location with gray level 255 pattern (cd/m<sup>2</sup>)

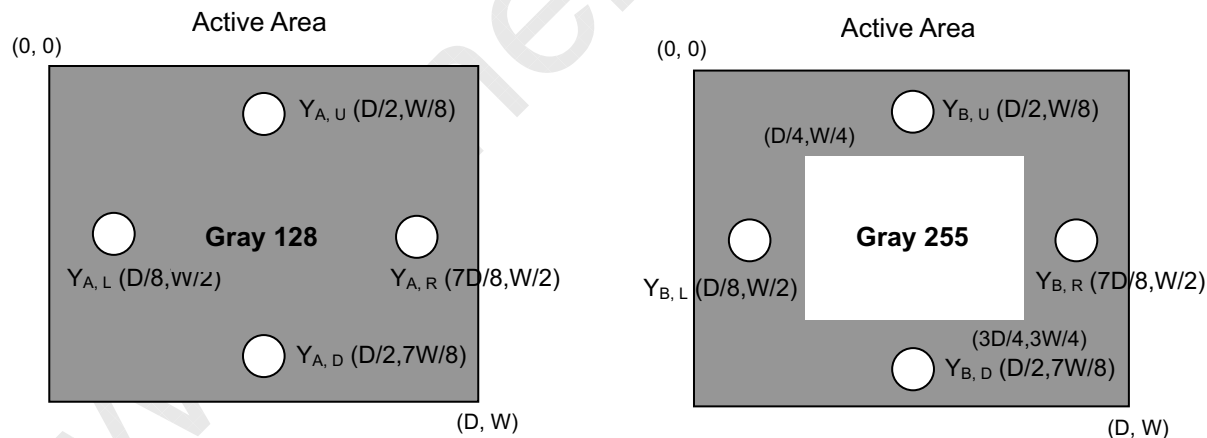

Note (6) Definition of White Variation ( $\delta W$ ):

Measure the luminance of gray level 255 at 5 points

$$\delta W = \text{Maximum} [L(1), L(2), L(3), L(4), L(5)] / \text{Minimum} [L(1), L(2), L(3), L(4), L(5)]$$

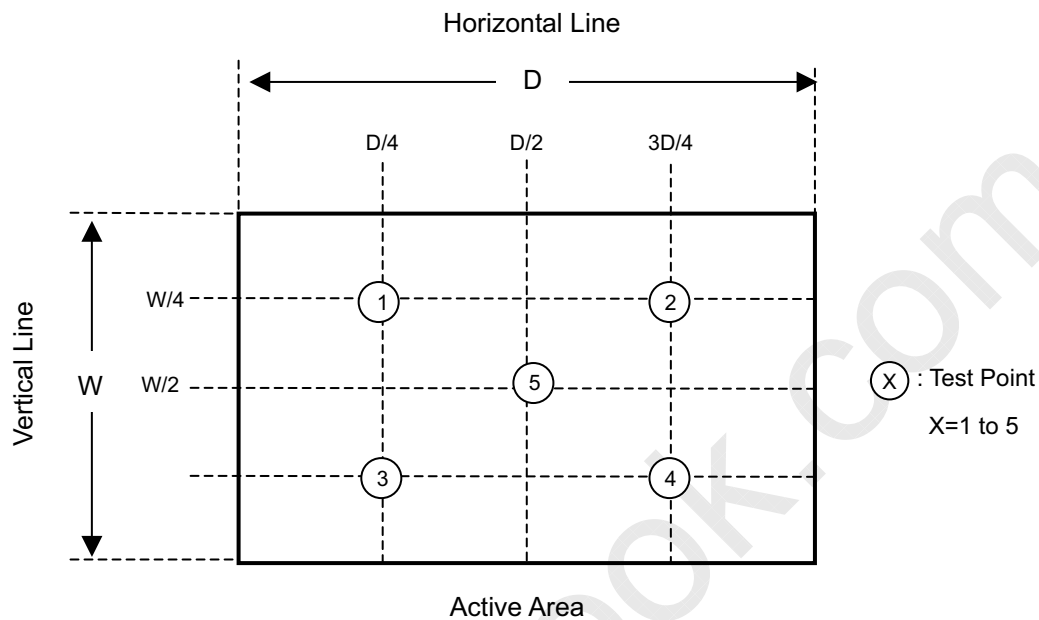

## 8. PRECAUTIONS

### 8.1 ASSEMBLY AND HANDLING PRECAUTIONS

- [ 1 ] Do not apply rough force such as bending or twisting to the module during assembly.
- [ 2 ] It is recommended to assemble or to install a module into the user's system in clean working areas. The dust and oil may cause electrical short or worsen the polarizer.
- [ 3 ] Do not apply pressure or impulse to the module to prevent the damage of LCD panel and Backlight.
- [ 4 ] Always follow the correct power-on sequence when the LCD module is turned on. This can prevent the damage and latch-up of the CMIS LSI chips.
- [ 5 ] Bezel of Set can not press or touch the panel surface. It will make light leakage or scrape.
- [ 6 ] Do not plug in or pull out the I/F connector while the module is in operation.
- [ 7 ] Do not disassemble the module.
- [ 8 ] Use a soft dry cloth without chemicals for cleaning, because the surface of polarizer is very soft and easily scratched.
- [ 9 ] Moisture can easily penetrate into LCD module and may cause the damage during operation.
- [ 10 ] When storing modules as spares for a long time, the following precaution is necessary.
  - [ 10.1 ] Do not leave the module in high temperature, and high humidity for a long time. It is highly recommended to store the module with temperature from 0 to 35°C at normal humidity without condensation.
  - [ 10.2 ] The module shall be stored in dark place. Do not store the TFT-LCD module in direct sunlight or fluorescent light.
- [ 11 ] When ambient temperature is lower than 10°C, the display quality might be reduced. For example, the response time will become slow, and the starting voltage of CCFL will be higher than that of room temperature.

### 8.2 SAFETY PRECAUTIONS

- [ 1 ] The startup voltage of a Backlight is approximately 1000 Volts. It may cause an electrical shock while assembling with the converter. Do not disassemble the module or insert anything into the Backlight unit.
- [ 2 ] If the liquid crystal material leaks from the panel, it should be kept away from the eyes or mouth. In case of contact with hands, skin or clothes, it has to be washed away thoroughly with soap.
- [ 3 ] After the module's end of life, it is not harmful in case of normal operation and storage.

## 9. DEFINITION OF LABELS

### 9.1 CMI MODULE LABEL

The barcode nameplate is pasted on each module as illustration, and its definitions are as following explanation.

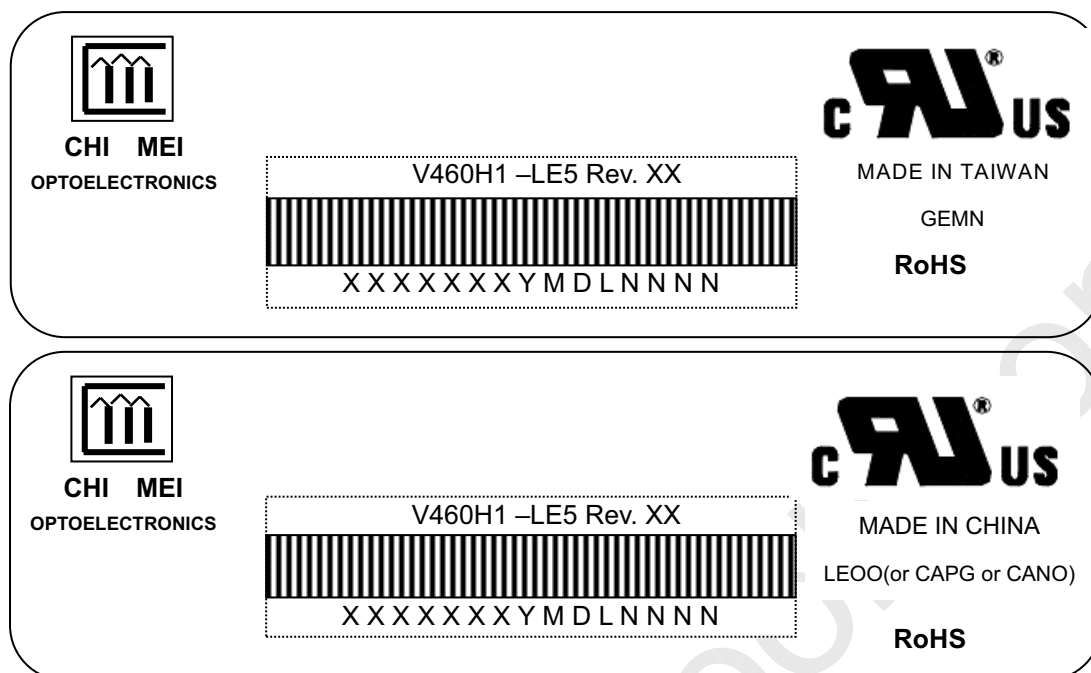

Model Name: V460H1-LE5

Revision: Rev. XX, for example: A0, A1... B1, B2... or C1, C2...etc.

Serial ID: X X X X X X Y M D L N N N N

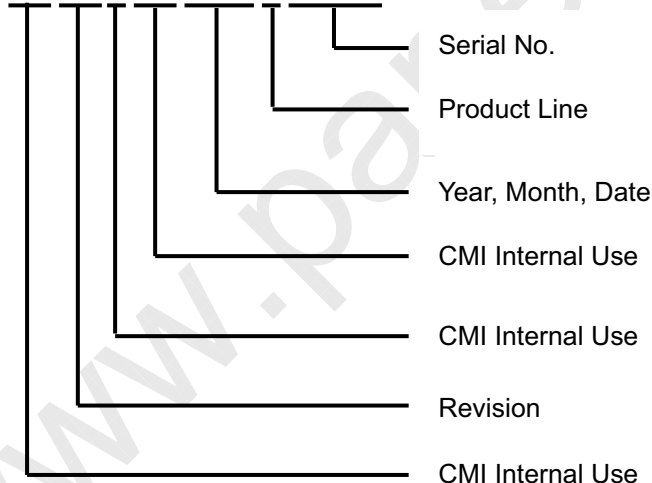

Serial ID includes the information as below:

Manufactured Date:

Year : 2001=1, 2002=2, 2003=3, 2004=4...2010=0, 2011=1, 2012=2...

Month: 1~9, A~C, for Jan. ~ Dec.

Day: 1~9, A~Y, for 1st to 31st, exclude I, O, and U.

Revision Code : Cover all the change

Serial No. : Manufacturing sequence of product

Product Line : 1 → Line1, 2 → Line 2, ...etc.



## 10. PACKAGING

### 10.1 PACKAGING SPECIFICATIONS

- (1) 5 LCD TV modules / 1 Box
- (2) Box dimensions: 1175(L)x 282(W)x 700(H)mm
- (3) Weight: approximately 58Kg (5 modules per box)

### 10.2 PACKAGING METHOD

Figures 10-1 and 10-2 are the packing method

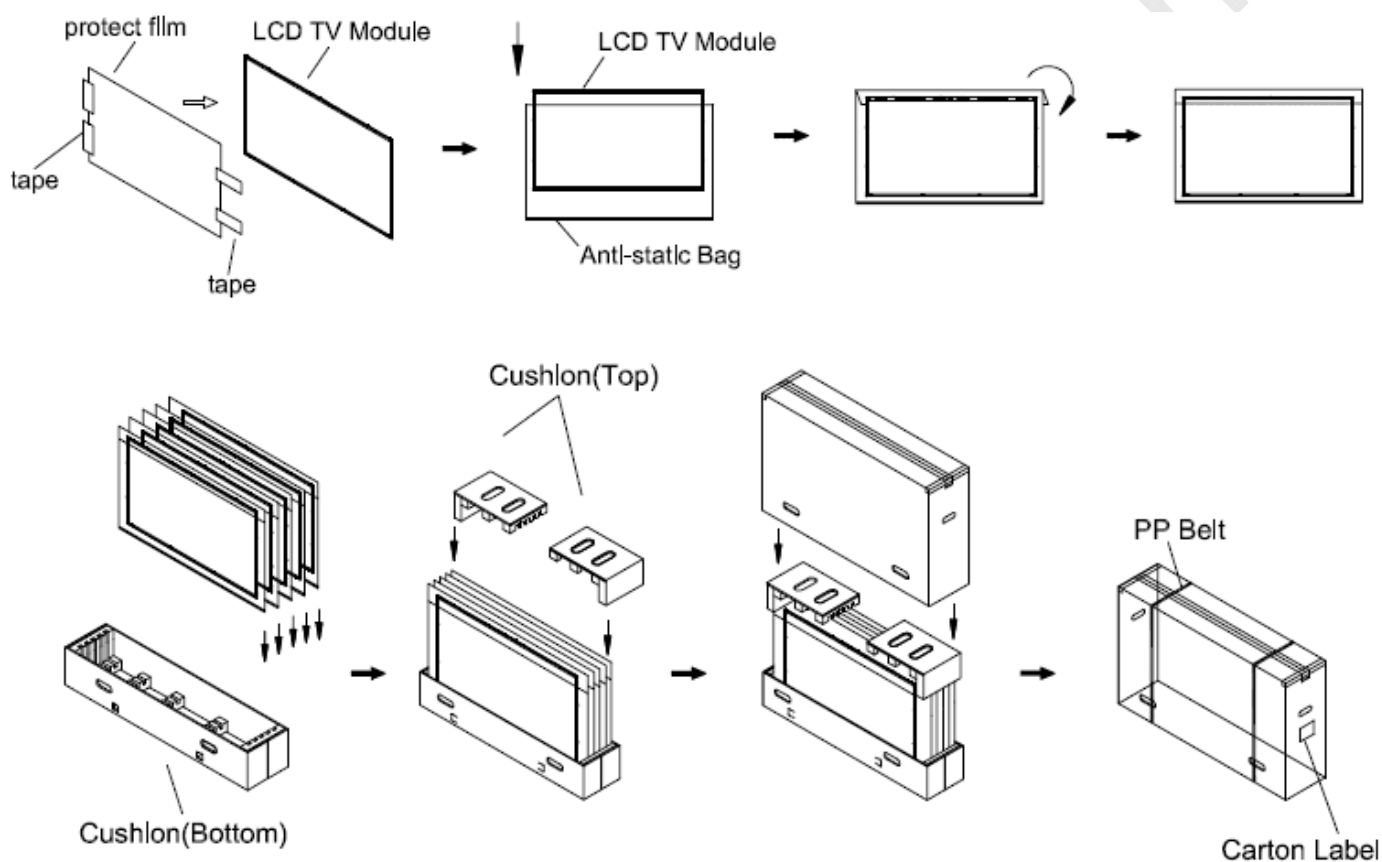
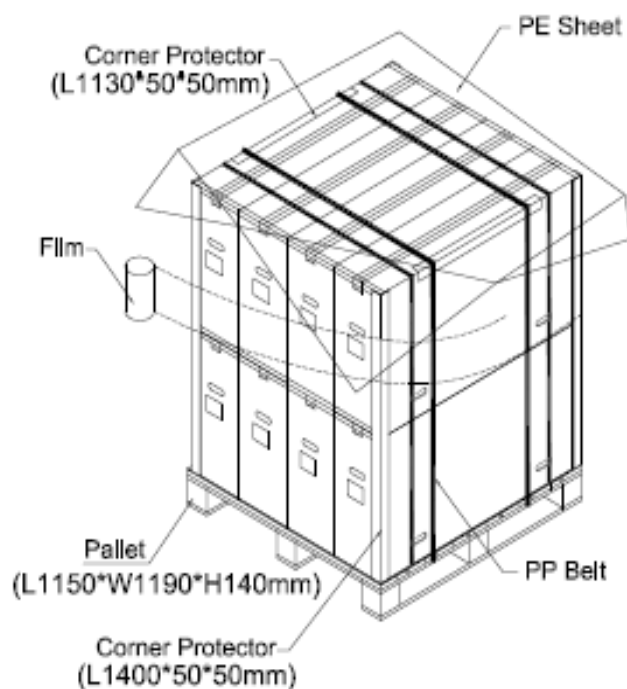

Figure 10-1 packing method

## Air Transportation & Sea / Land Transportation (40ft Container)



## Sea / Land Transportation (40ft HQ Container)

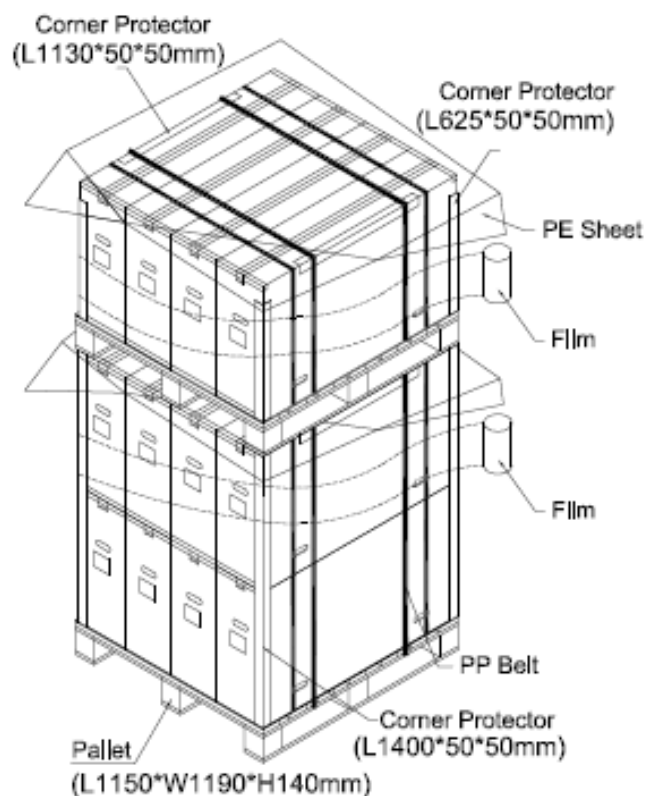
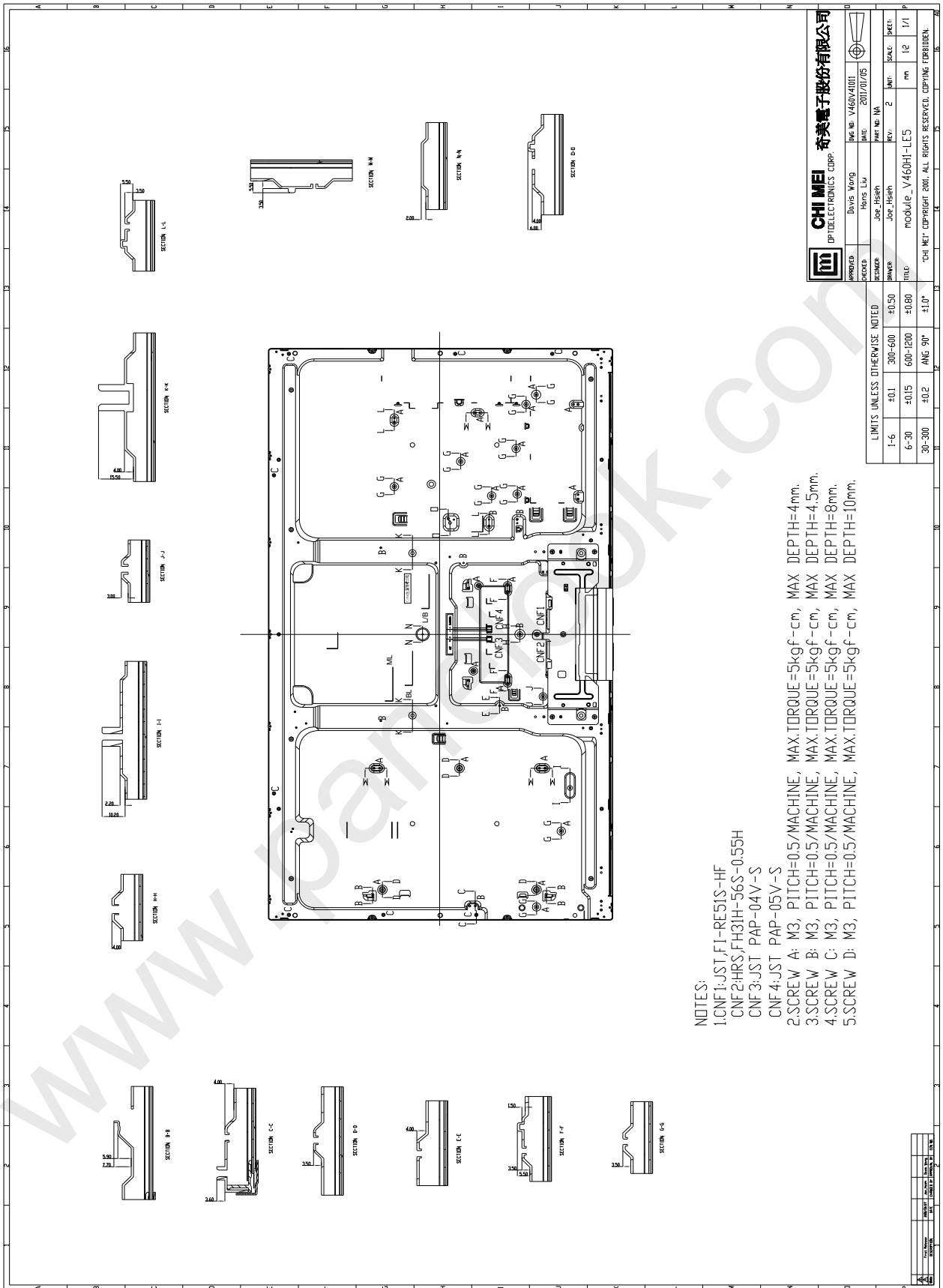
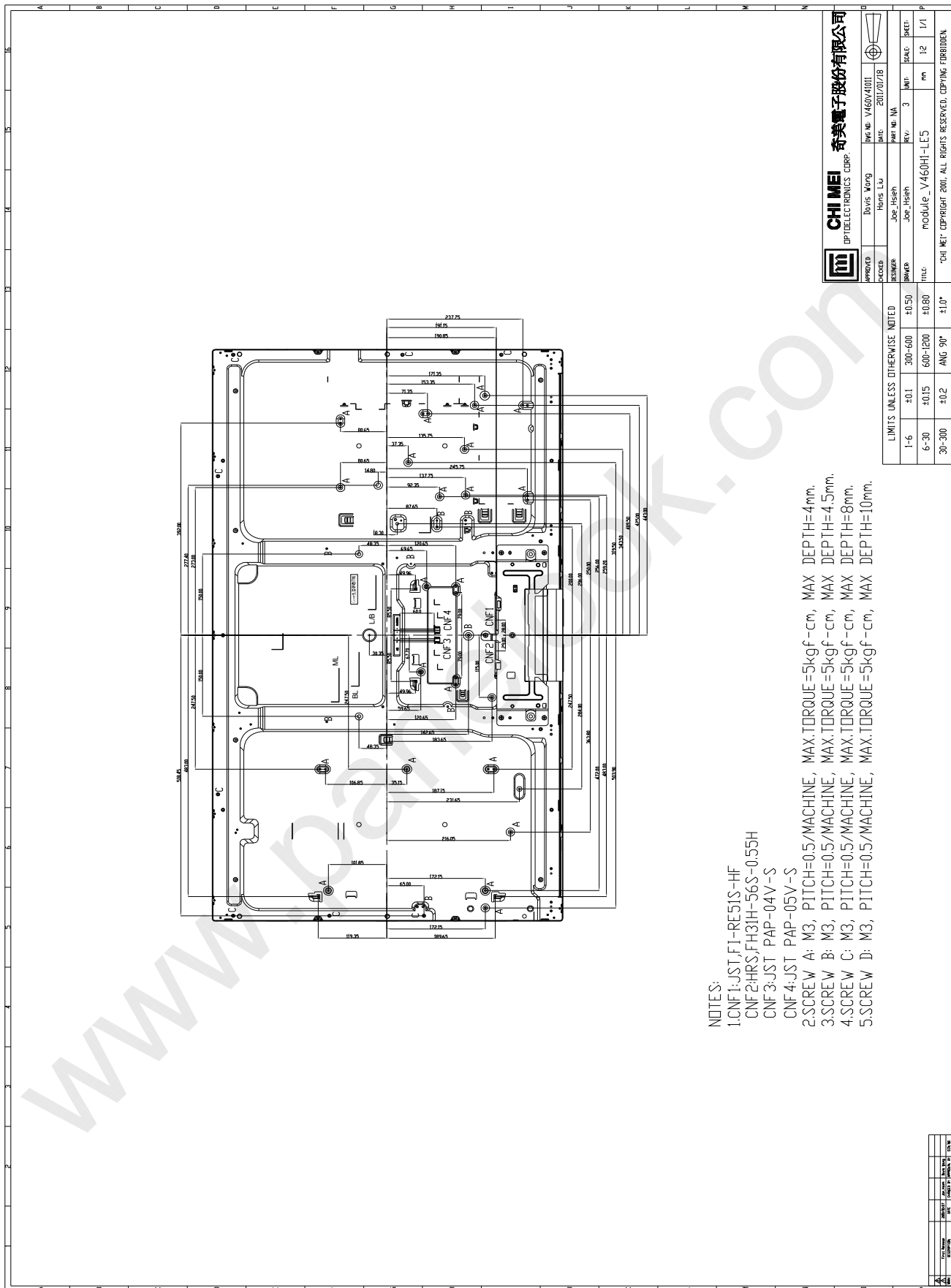

Figure.10-2 packing method







NOTES:

- 1.CNF1:JST,FI-RE51S-HF
- 2.CNF2:HRS,FH31H-56S-055H
- 3.CNF3:JST PAP-04V-S
- 4.CNF4:JST PAP-05V-S
- 5.SCREW A: M3, PITCH=0.5/MACHINE, MAX.TORQUE=5kgf-cm, MAX DEPTH=4mm.
- 6.SCREW B: M3, PITCH=0.5/MACHINE, MAX.TORQUE=5kgf-cm, MAX DEPTH=4.5mm.
- 7.SCREW C: M3, PITCH=0.5/MACHINE, MAX.TORQUE=5kgf-cm, MAX DEPTH=8mm.
- 8.SCREW D: M3, PITCH=0.5/MACHINE, MAX.TORQUE=5kgf-cm, MAX DEPTH=10mm.

**CHI MEI**  
OPTOELECTRONICS CORP.  
奇美電子股份有限公司

DESIGNED	David Wang	REV. NO.	Y460H1-LE5
DRAWN	Hans Lu	DATE	2011/07/18
CHECKED	Joe Hsieh	REV.	3
DATE	2011/07/18	UNIT	mm
SCALE	1:1	SCALE	1:1
TITLE	MODULE_Y460H1-LE5		
*CHI MEI COPYRIGHT 2001. ALL RIGHTS RESERVED. COPYING FORBIDDEN.			

LIMITS UNLESS OTHERWISE NOTED	
1-6	+0.1
6-30	+0.15
30-300	+0.2
300-600	+0.50
600-1200	+0.80
1200-2400	+1.00
2400-4800	+1.50
4800-9600	+2.00
9600-19200	+3.00
19200-38400	+4.00
38400-76800	+5.00
76800-153600	+6.00
153600-307200	+7.00
307200-614400	+8.00
614400-1228800	+9.00
1228800-2457600	+10.00
2457600-4915200	+11.00
4915200-9830400	+12.00
9830400-19660800	+13.00
19660800-39321600	+14.00
39321600-78643200	+15.00
78643200-157286400	+16.00
157286400-314572800	+17.00
314572800-629145600	+18.00
629145600-1258291200	+19.00
1258291200-2516582400	+20.00
2516582400-5033164800	+21.00
5033164800-10066329600	+22.00
10066329600-20132659200	+23.00
20132659200-40265318400	+24.00
40265318400-80530636800	+25.00
80530636800-161061273600	+26.00
161061273600-322122547200	+27.00
322122547200-644245094400	+28.00
644245094400-1288490188800	+29.00
1288490188800-2576980377600	+30.00
2576980377600-5153960755200	+31.00
5153960755200-10307921510400	+32.00
10307921510400-20615843020800	+33.00
20615843020800-41231686041600	+34.00
41231686041600-82463372083200	+35.00
82463372083200-164926744166400	+36.00
164926744166400-329853488332800	+37.00
329853488332800-659706976665600	+38.00
659706976665600-1319413953331200	+39.00
1319413953331200-2638827906662400	+40.00
2638827906662400-5277655813324800	+41.00
5277655813324800-10555311626649600	+42.00
10555311626649600-21110623253299200	+43.00
21110623253299200-42221246506598400	+44.00
42221246506598400-84442493013196800	+45.00
84442493013196800-168884986026393600	+46.00
168884986026393600-337769972052787200	+47.00
337769972052787200-675539944105574400	+48.00
675539944105574400-1351079888211148800	+49.00
1351079888211148800-2702159776422297600	+50.00
2702159776422297600-5404319552844595200	+51.00
5404319552844595200-1080863910568918400	+52.00
1080863910568918400-2161727821137836800	+53.00
2161727821137836800-4323455642275673600	+54.00
4323455642275673600-8646911284551347200	+55.00
8646911284551347200-17293822569102694400	+56.00
17293822569102694400-34587645138205388800	+57.00
34587645138205388800-69175290276410777600	+58.00
69175290276410777600-13835058055282155200	+59.00
13835058055282155200-27670116110564310400	+60.00
27670116110564310400-55340232221128620800	+61.00
55340232221128620800-110680464422257241600	+62.00
110680464422257241600-221360928844514483200	+63.00
221360928844514483200-442721857689028966400	+64.00
442721857689028966400-885443715378057932800	+65.00
885443715378057932800-1770887430756115865600	+66.00
1770887430756115865600-3541774861512231731200	+67.00
3541774861512231731200-7083549723024463462400	+68.00
7083549723024463462400-1416709944604930924800	+69.00
1416709944604930924800-2833419889209861849600	+70.00
2833419889209861849600-5666839778419723699200	+71.00
5666839778419723699200-11333679556839447398400	+72.00
11333679556839447398400-22667359113678894796800	+73.00
22667359113678894796800-45334718227357789593600	+74.00
45334718227357789593600-90669436454715579187200	+75.00
90669436454715579187200-181338872909431158374400	+76.00
181338872909431158374400-362677745818862316748800	+77.00
362677745818862316748800-725355491637724633497600	+78.00
725355491637724633497600-1450710923275449266995200	+79.00
1450710923275449266995200-2901421846550898533990400	+80.00
2901421846550898533990400-5802843693101797067980800	+81.00
5802843693101797067980800-11605687386203594134961600	+82.00
11605687386203594134961600-23211374772407188269923200	+83.00
23211374772407188269923200-46422749544814376539966400	+84.00
46422749544814376539966400-92845499089628753079932800	+85.00
92845499089628753079932800-185690998179257506159665600	+86.00
185690998179257506159665600-371381996358515012319331200	+87.00
371381996358515012319331200-742763992717030024638662400	+88.00
742763992717030024638662400-1485527985354060049277324800	+89.00
1485527985354060049277324800-2971055970708120098554649600	+90.00
2971055970708120098554649600-594211194141624019711139200	+91.00
594211194141624019711139200-1188422388283248038422278400	+92.00
1188422388283248038422278400-2376844776566496076844556800	+93.00
2376844776566496076844556800-4753689553132992153691113600	+94.00
4753689553132992153691113600-950737910626598427378227200	+95.00
950737910626598427378227200-1901475821253196854756454400	+96.00
1901475821253196854756454400-3802951642506393709512908800	+97.00
3802951642506393709512908800-7605903285012787419025817600	+98.00
7605903285012787419025817600-15211806570025574838051635200	+99.00
15211806570025574838051635200-30423613140051149676102670400	+100.00